

	CONCI 1/2	CONCI 2/3/4	CONCI 4/5
COLLEGAMENTO			
SPessori FLANGE SUPERIORI (mm)	30-30	30-30	30-30
SPessori ANIME (mm)	20-20	20-20	20-20
SPessori FLANGE INFERIORI (mm)	40-60	60-60	60-40
Particolari saldature (scala 1:5)			
Anima			
Plattabanda inferiore			

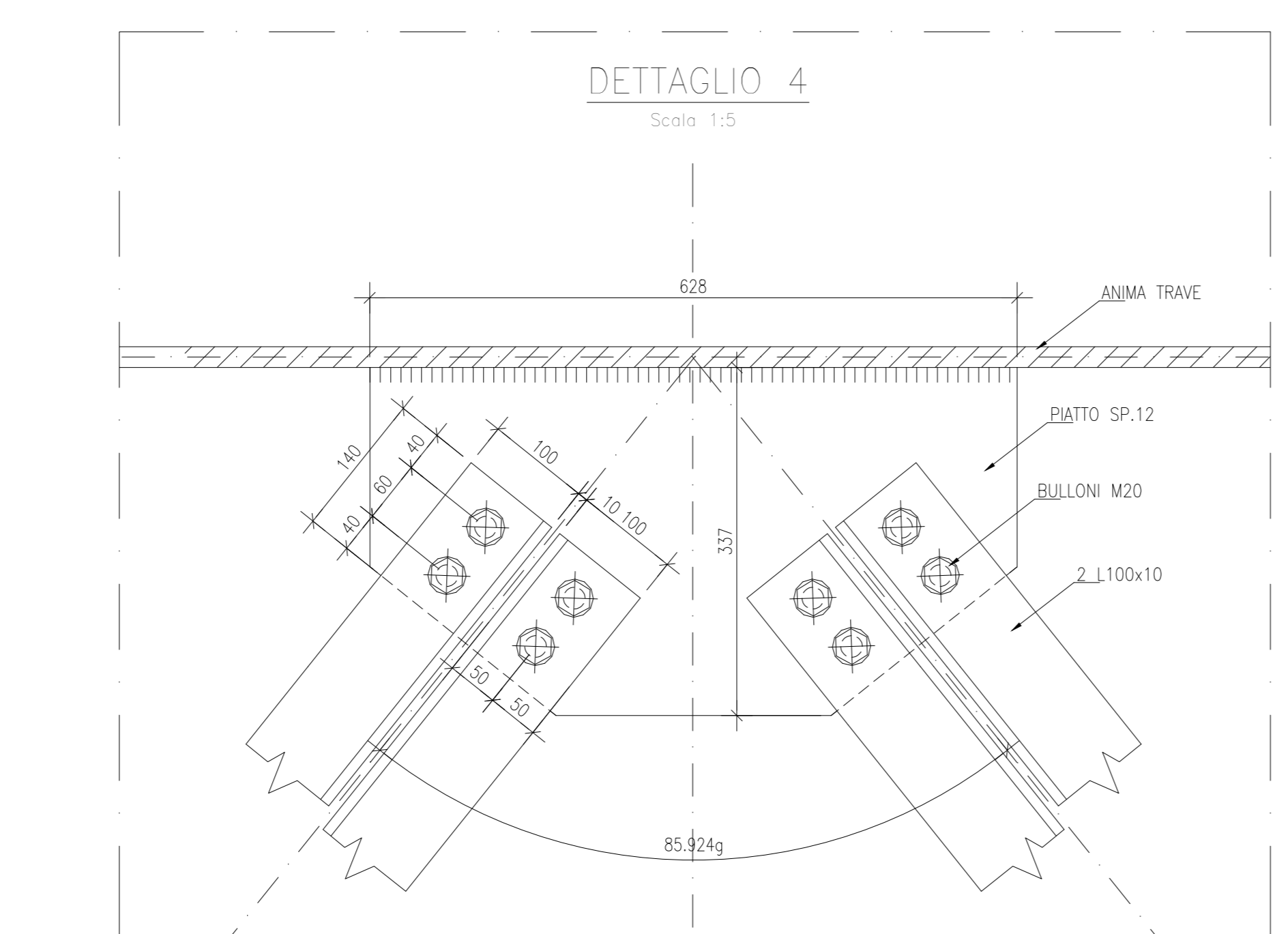
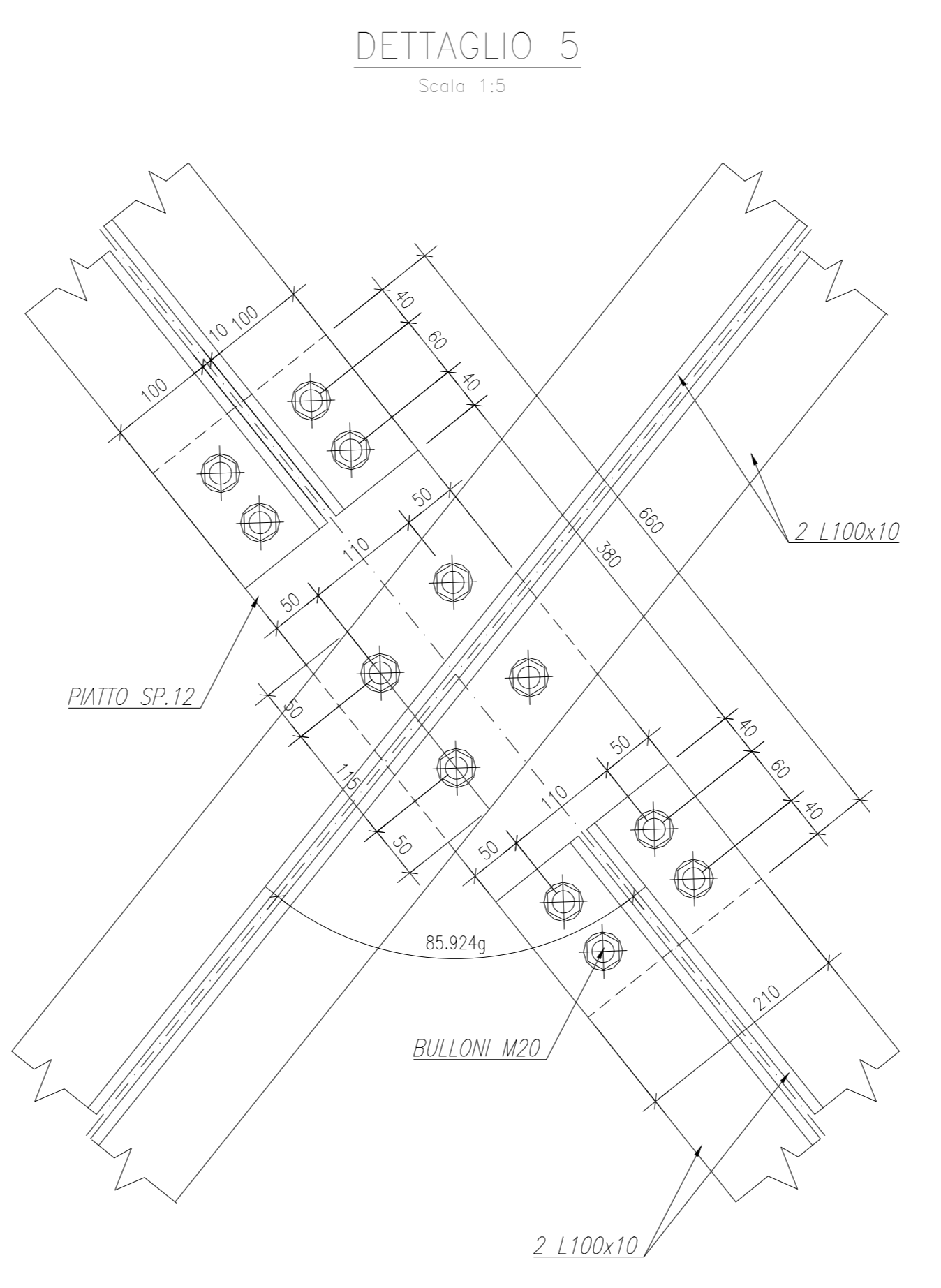
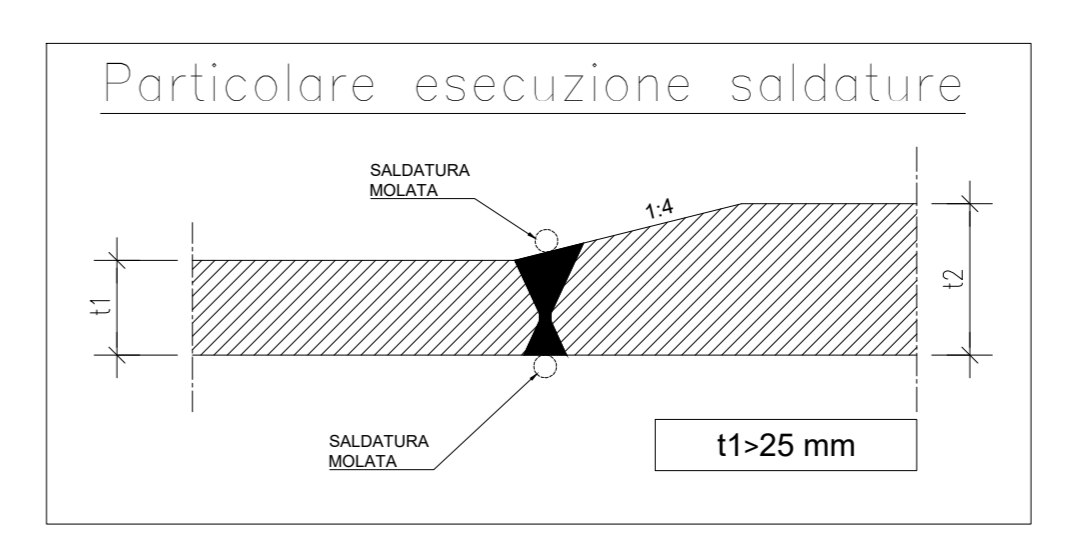
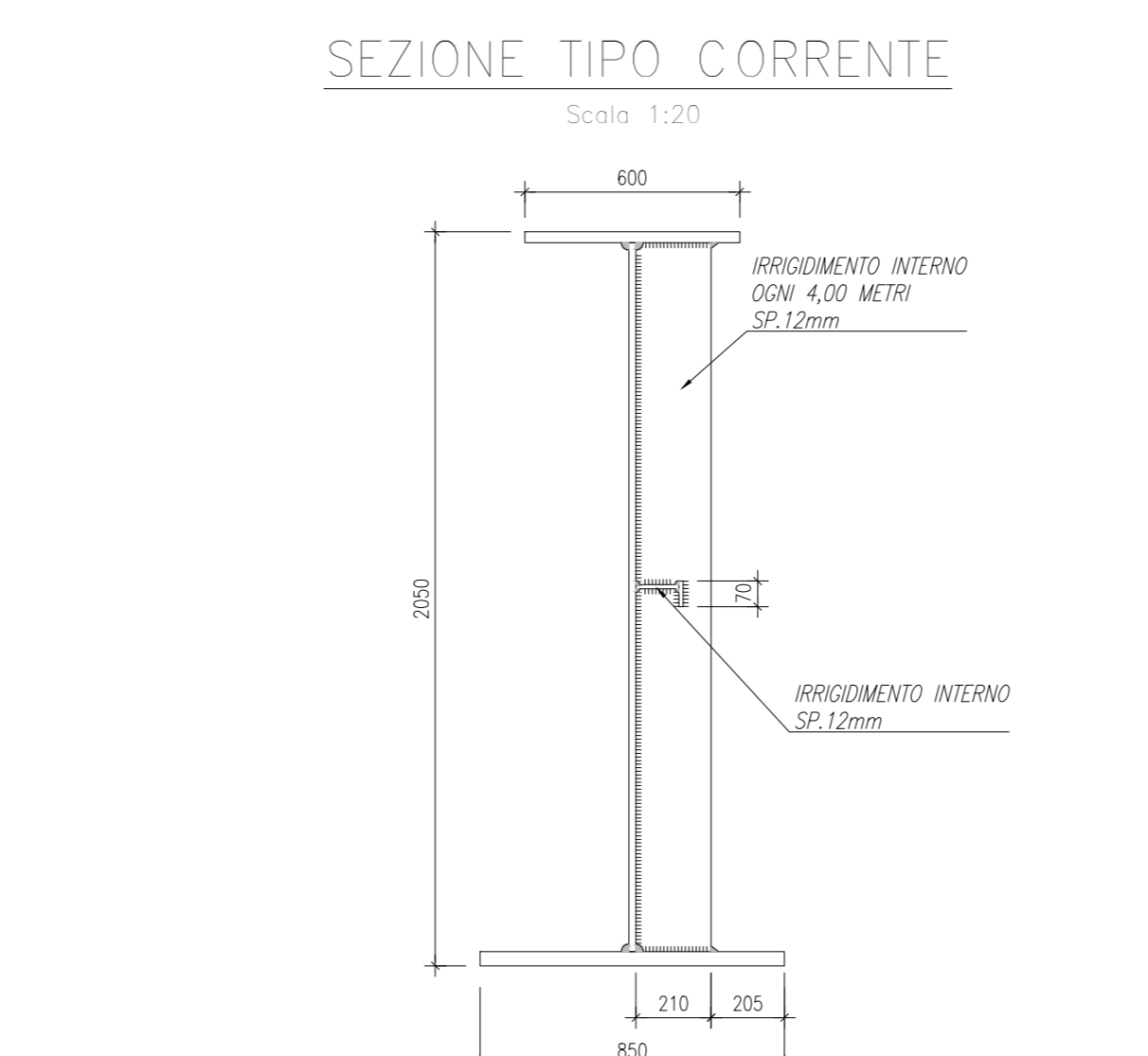
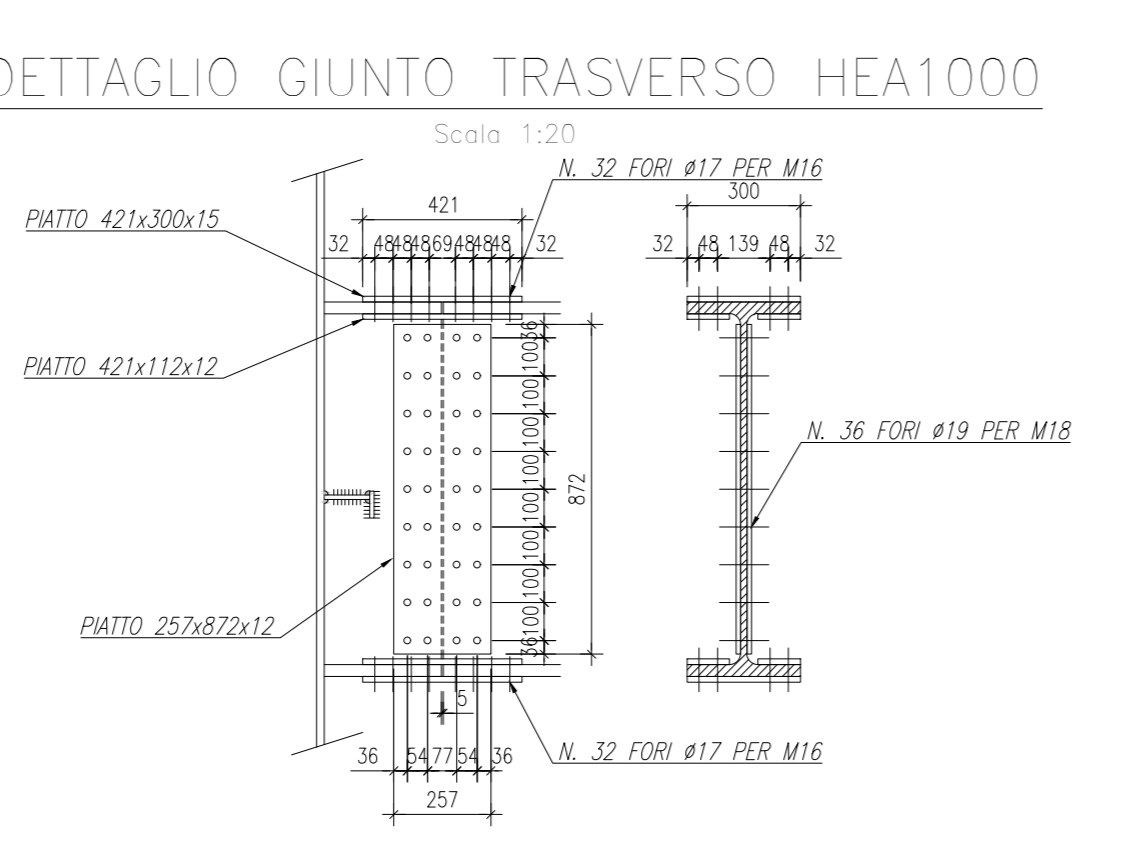
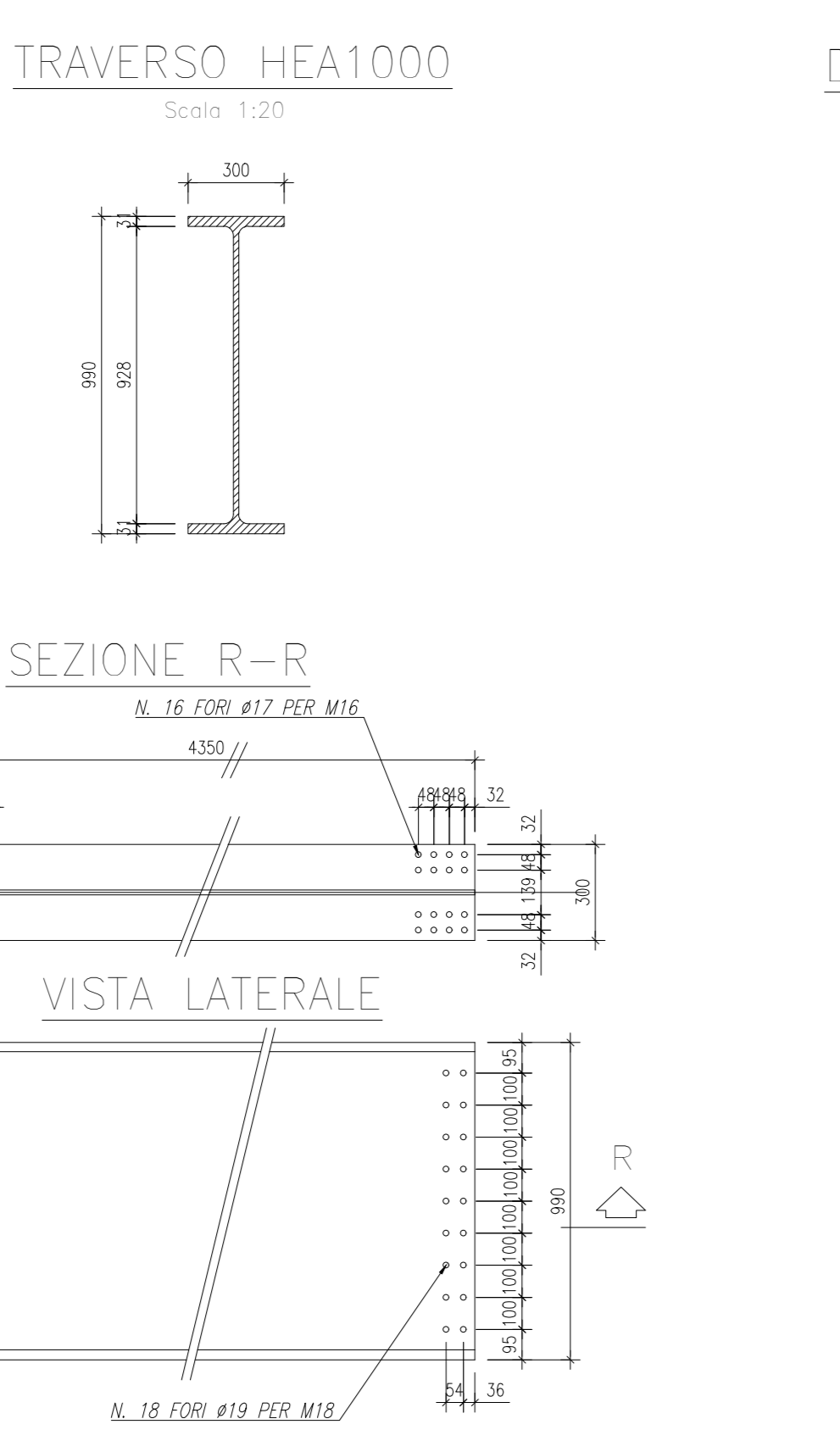
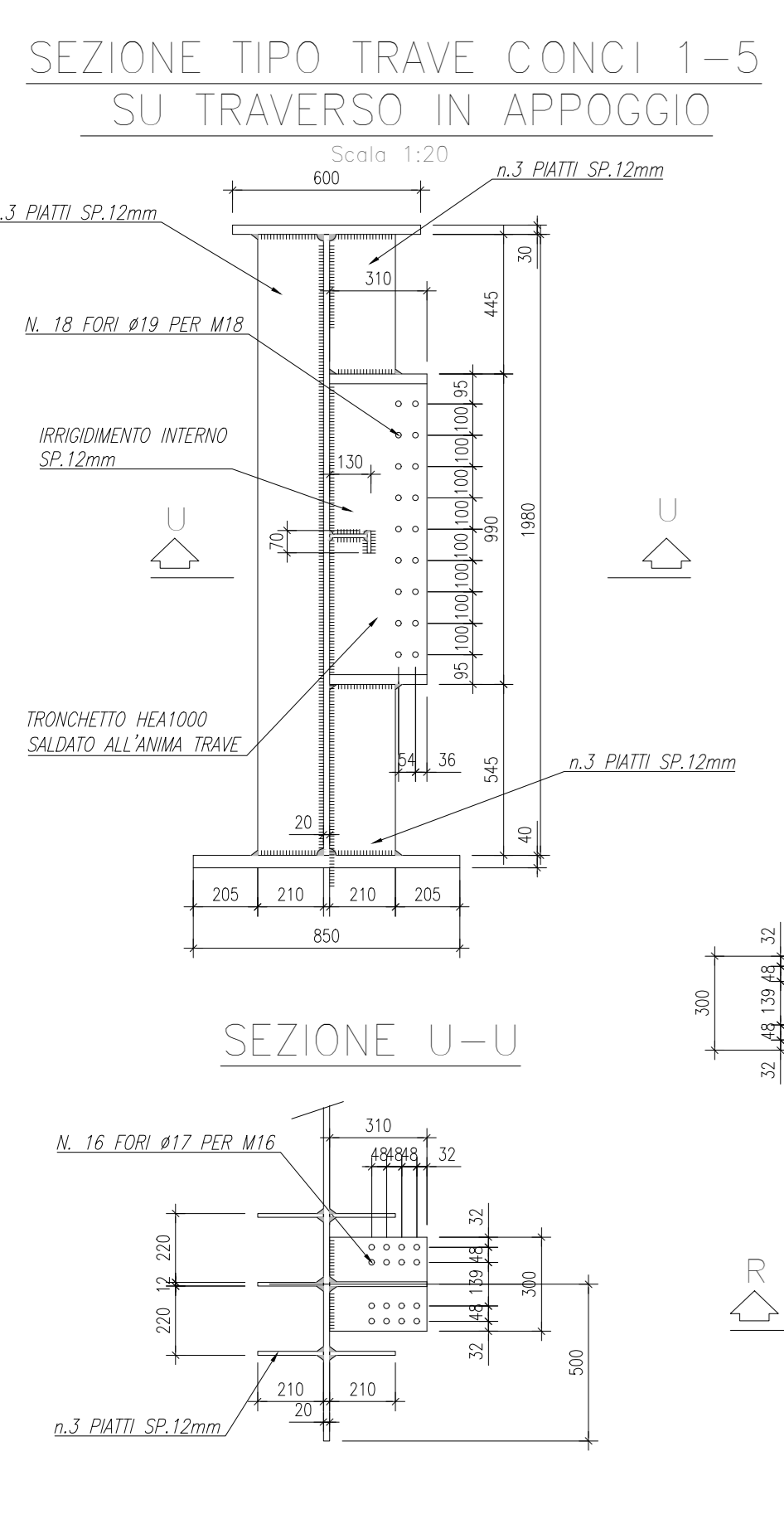

SALDATE TIPO A CORDONE D'ANGOLO

SCHEMA GENERALE PER SALDATURA SU ENTAMBI I LATI

SCHEMA GENERALE PER SALDATURA SU UN SOLO LATO

SALDATE TIPO A PIENA PENETRAZIONE

SALDATURA A MEZZA V

SALDATURA A K

SALDATURA A V

SALDATURA A DOPPIA V

NOTE

- Garantire la completa sigillatura di tutte le saldature.
- Eventuali giunti tecnici inseriti dal costruttore dovranno essere preventivamente approvati dal progettista e comunque saranno eseguiti a piena penetrazione e sporcificati di 100%; con spessore di 4/5/6/7/8/9/10/11/12/13/14/15/16/17/18/19/20/21/22/23/24/25/26/27/28/29/30/31/32/33/34/35/36/37/38/39/40/41/42/43/44/45/46/47/48/49/50/51/52/53/54/55/56/57/58/59/60/61/62/63/64/65/66/67/68/69/70/71/72/73/74/75/76/77/78/79/80/81/82/83/84/85/86/87/88/89/90/91/92/93/94/95/96/97/98/99/100/101/102/103/104/105/106/107/108/109/110/111/112/113/114/115/116/117/118/119/120/121/122/123/124/125/126/127/128/129/130/131/132/133/134/135/136/137/138/139/140/141/142/143/144/145/146/147/148/149/150/151/152/153/154/155/156/157/158/159/160/161/162/163/164/165/166/167/168/169/170/171/172/173/174/175/176/177/178/179/180/181/182/183/184/185/186/187/188/189/190/191/192/193/194/195/196/197/198/199/200/201/202/203/204/205/206/207/208/209/210/211/212/213/214/215/216/217/218/219/220/221/222/223/224/225/226/227/228/229/230/231/232/233/234/235/236/237/238/239/240/241/242/243/244/245/246/247/248/249/250/251/252/253/254/255/256/257/258/259/260/261/262/263/264/265/266/267/268/269/270/271/272/273/274/275/276/277/278/279/280/281/282/283/284/285/286/287/288/289/290/291/292/293/294/295/296/297/298/299/300/301/302/303/304/305/306/307/308/309/310/311/312/313/314/315/316/317/318/319/320/321/322/323/324/325/326/327/328/329/330/331/332/333/334/335/336/337/338/339/340/341/342/343/344/345/346/347/348/349/350/351/352/353/354/355/356/357/358/359/360/361/362/363/364/365/366/367/368/369/370/371/372/373/374/375/376/377/378/379/380/381/382/383/384/385/386/387/388/389/390/391/392/393/394/395/396/397/398/399/400/401/402/403/404/405/406/407/408/409/410/411/412/413/414/415/416/417/418/419/420/421/422/423/424/425/426/427/428/429/430/431/432/433/434/435/436/437/438/439/440/441/442/443/444/445/446/447/448/449/450/451/452/453/454/455/456/457/458/459/460/461/462/463/464/465/466/467/468/469/470/471/472/473/474/475/476/477/478/479/480/481/482/483/484/485/486/487/488/489/490/491/492/493/494/495/496/497/498/499/500/501/502/503/504/505/506/507/508/509/510/511/512/513/514/515/516/517/518/519/520/521/522/523/524/525/526/527/528/529/530/531/532/533/534/535/536/537/538/539/540/541/542/543/544/545/546/547/548/549/550/551/552/553/554/555/556/557/558/559/560/561/562/563/564/565/566/567/568/569/570/571/572/573/574/575/576/577/578/579/580/581/582/583/584/585/586/587/588/589/590/591/592/593/594/595/596/597/598/599/600/601/602/603/604/605/606/607/608/609/610/611/612/613/614/615/616/617/618/619/620/621/622/623/624/625/626/627/628/629/630/631/632/633/634/635/636/637/638/639/640/641/642/643/644/645/646/647/648/649/650/651/652/653/654/655/656/657/658/659/660/661/662/663/664/665/666/667/668/669/670/671/672/673/674/675/676/677/678/679/680/681/682/683/684/685/686/687/688/689/690/691/692/693/694/695/696/697/698/699/700/701/702/703/704/705/706/707/708/709/710/711/712/713/714/715/716/717/718/719/720/721/722/723/724/725/726/727/728/729/730/731/732/733/734/735/736/737/738/739/740/741/742/743/744/745/746/747/748/749/750/751/752/753/754/755/756/757/758/759/760/761/762/763/764/765/766/767/768/769/770/771/772/773/774/775/776/777/778/779/780/781/782/783/784/785/786/787/788/789/790/791/792/793/794/795/796/797/798/799/800/801/802/803/804/805/806/807/808/809/810/811/812/813/814/815/816/817/818/819/820/821/822/823/824/825/826/827/828/829/830/831/832/833/834/835/836/837/838/839/840/841/842/843/844/845/846/847/848/849/850/851/852/853/854/855/856/857/858/859/860/861/862/863/864/865/866/867/868/869/870/871/872/873/874/875/876/877/878/879/880/881/882/883/884/885/886/887/888/889/890/891/892/893/894/895/896/897/898/899/900/901/902/903/904/905/906/907/908/909/910/911/912/913/914/915/916/917/918/919/920/921/922/923/924/925/926/927/928/929/930/931/932/933/934/935/936/937/938/939/940/941/942/943/944/945/946/947/948/949/950/951/952/953/954/955/956/957/958/959/960/961/962/963/964/965/966/967/968/969/970/971/972/973/974/975/976/977/978/979/980/981/982/983/984/985/986/987/988/989/990/991/992/993/994/995/996/997/998/999/1000

Sanas
GRUPPO FS ITALIANE

ITINERARIO INTERNAZIONALE E78
S.G.C. GROSSETO - FANO
ADEGUAMENTO A 4 CORSIE
NEL TRATTO GROSSETO - SIENA (S.S. 223 "DI PAGANICO")
DAL KM 41+600 AL KM 53+400 - LOTTO 9

PROGETTO ESECUTIVO

PROGETTAZIONE: ATI SINTAGMA - GDG - ICARIA

Sintagma **GEOTECNICA** **ICARIA**

CAVALCAVIA
CAVALCAVIA FRONTIGNANO
Carpenteria Metallica impalcato - Sezioni e Particolari

NOTE GENERALI

- TUTTE LE MISURE DELLA CARPENTERIA METALLICA SONO ESPRESSE IN MILLIMETRI, SALVO OVE DIVERSAMENTE INDICATO
- TUTTE LE MISURE DELLA CARPENTERIA STRUTTURALE SONO ESPRESSE IN CENTIMETRI, SALVO OVE DIVERSAMENTE INDICATO
- PER LE CARATTERISTICHE DEI MATERIALI FARE RIFERIMENTO ALL'ELABORATO T00-CV02-STR-SC01

CODICE PROGETTO LQF115 E 1901 **NOME FILE** T00-CV02-STR-SC01 **REVISIONE** A **SCALA** -