

Schema con impiego di scatolari prefabbricati a SCALA 1:100

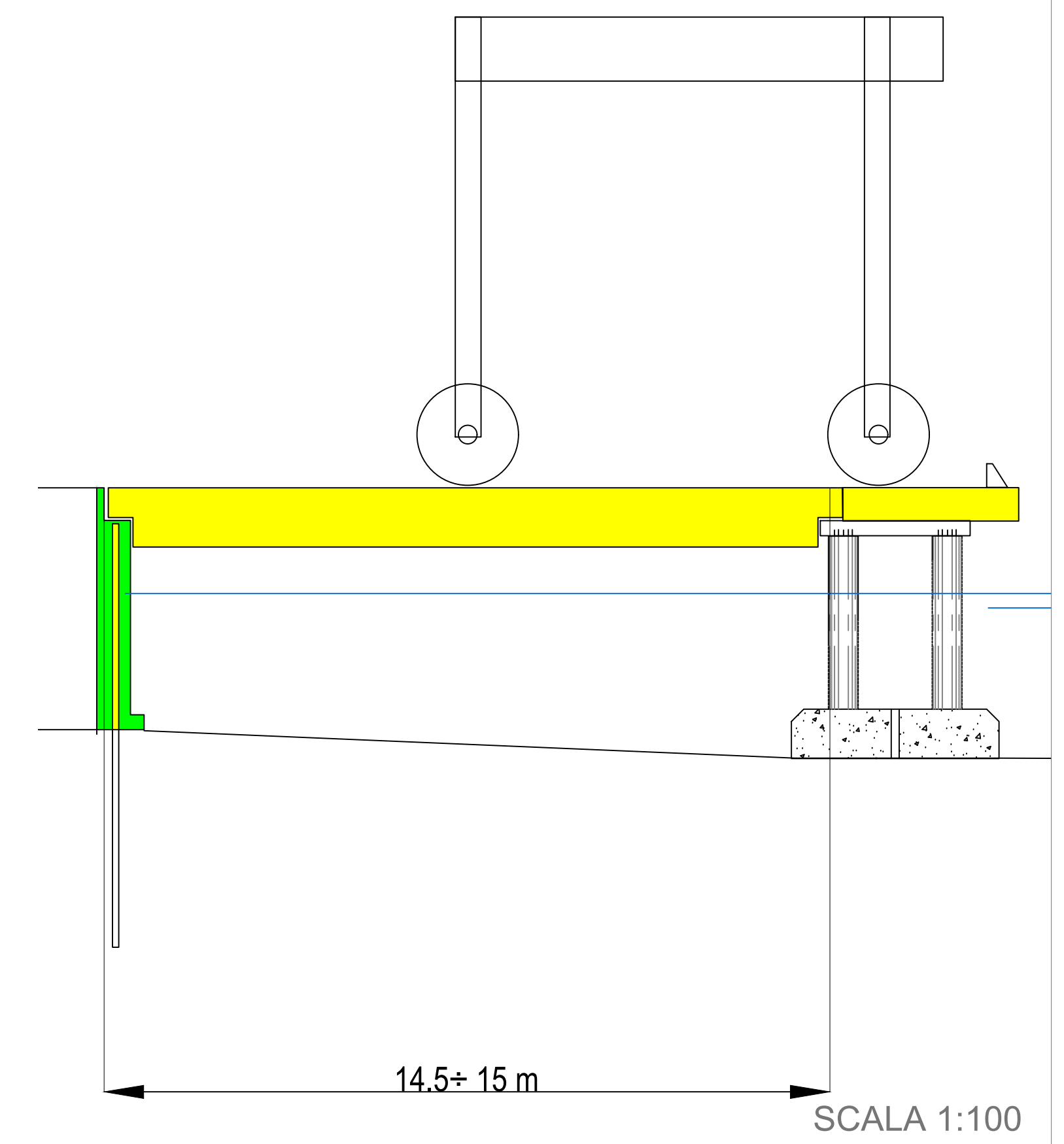

COMUNE DI ANDORA  
PROVINCIA DI SAVONA

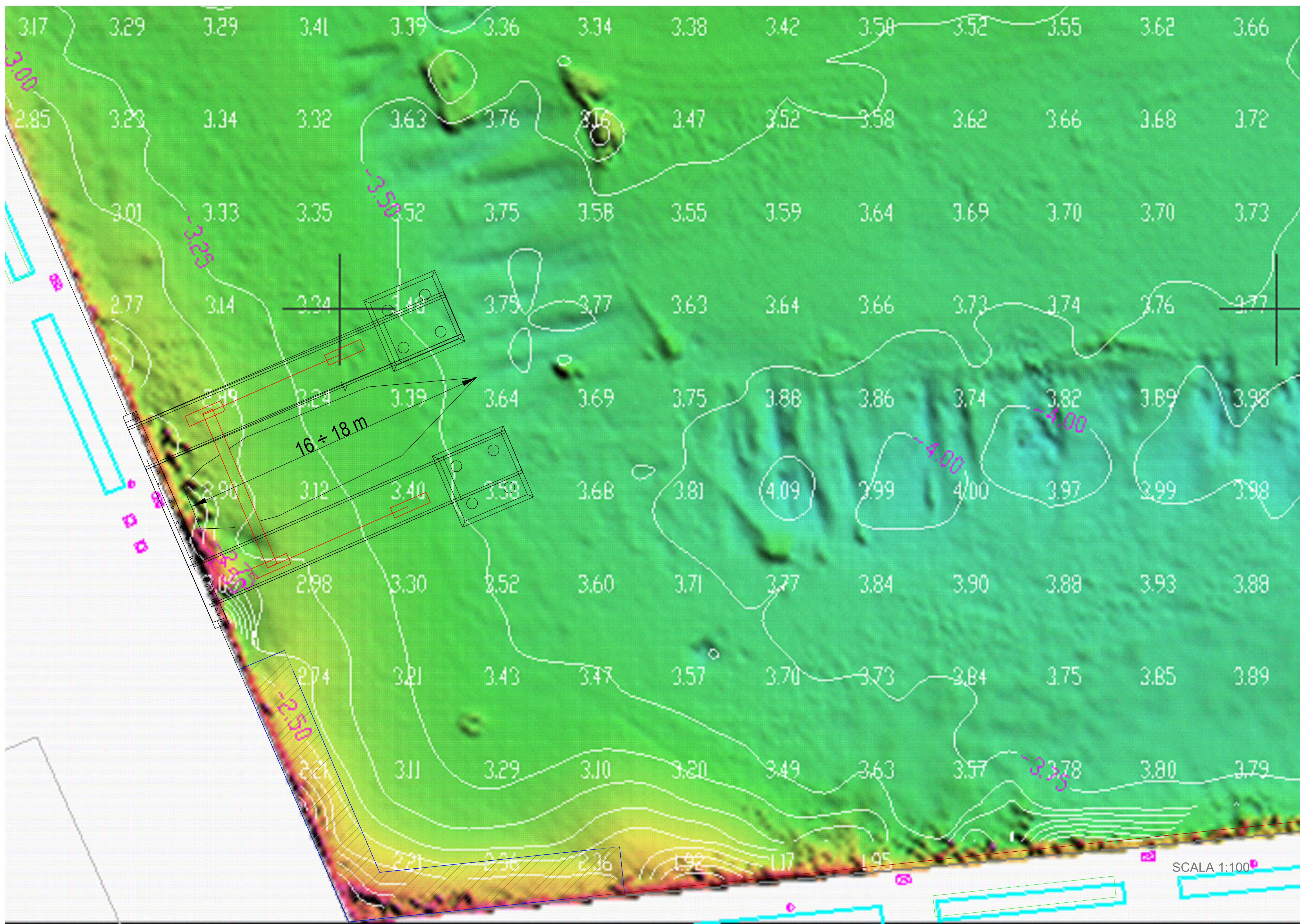
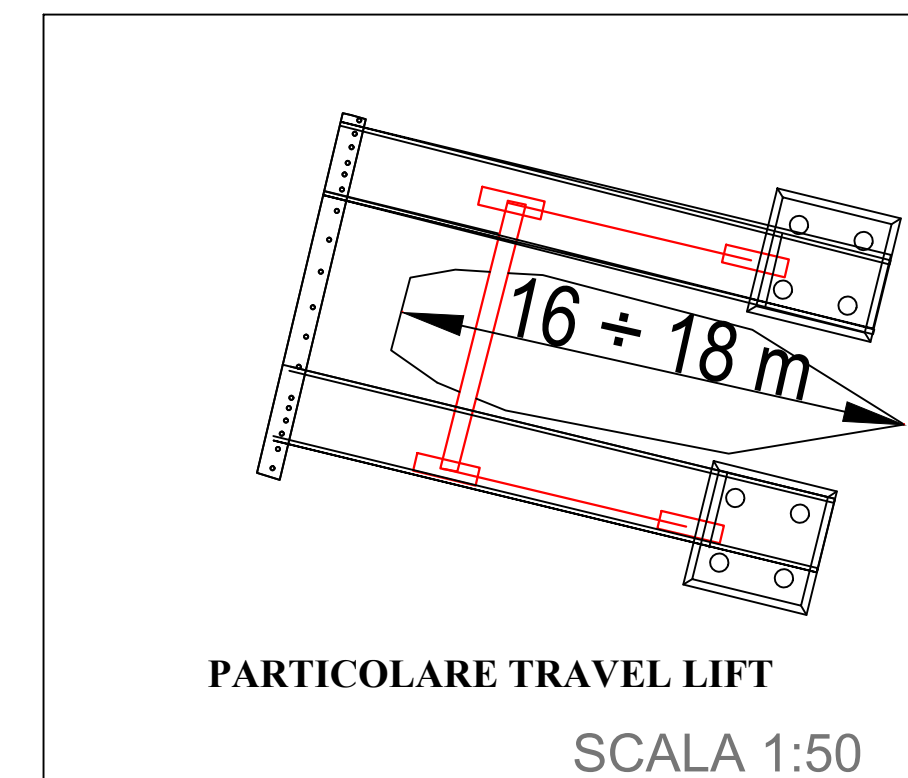

PUO A MODIFICA DELLO S.U.A. APPROVATO CON PROVVEDIMENTO FINALE IN DATA 16/03/2010 - DISTRETTO DI TRASFORMAZIONE TR-CO2 IN AGGIORNAMENTO AL PUC

oggetto					PROGETTO - Travel Lift
Scala					varie
Data					Maggio 2020
Progettisti					Arch. Paolo Ghione Geom. Anna Lisa Borghino Arch. Antonella Nalbone Arch. Isabella Rabellino
revisioni	data	note			Tavola
1	Maggio 2020	Modifiche a seguito conf. servizi			16
2					
3					
4					
5					