

FASI COSTRUTTIVE
 Realizzazione in due fasi.

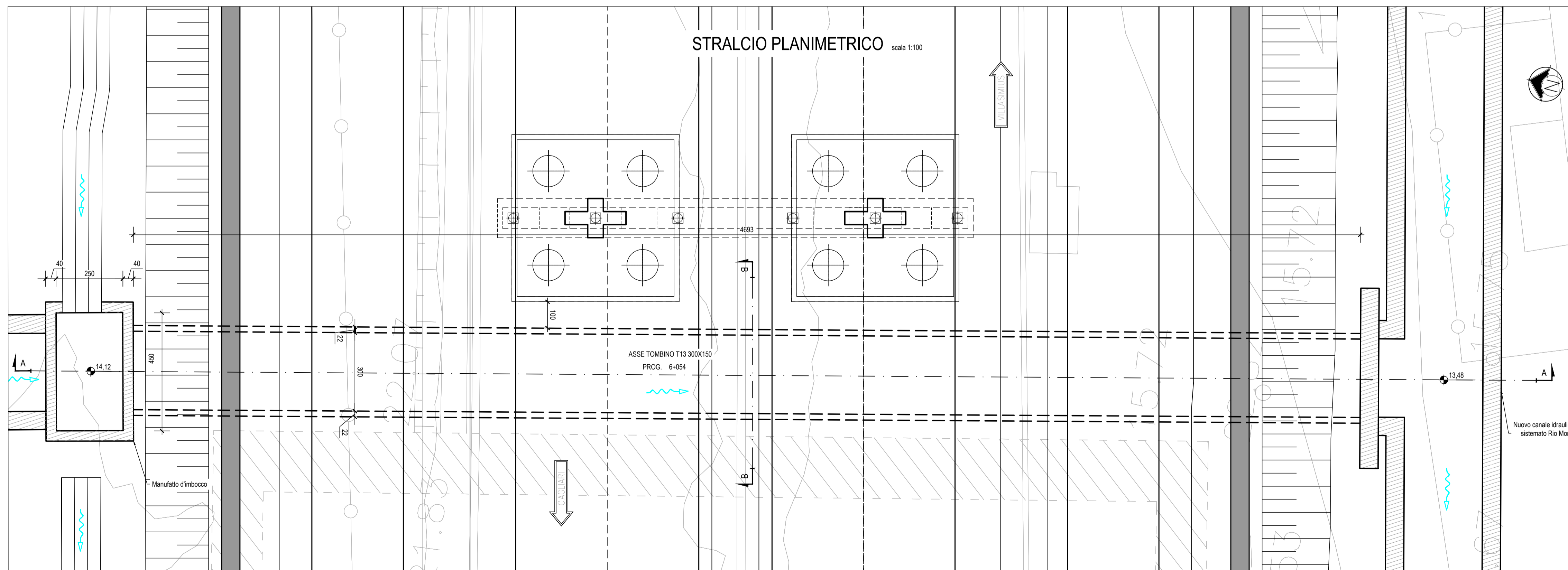

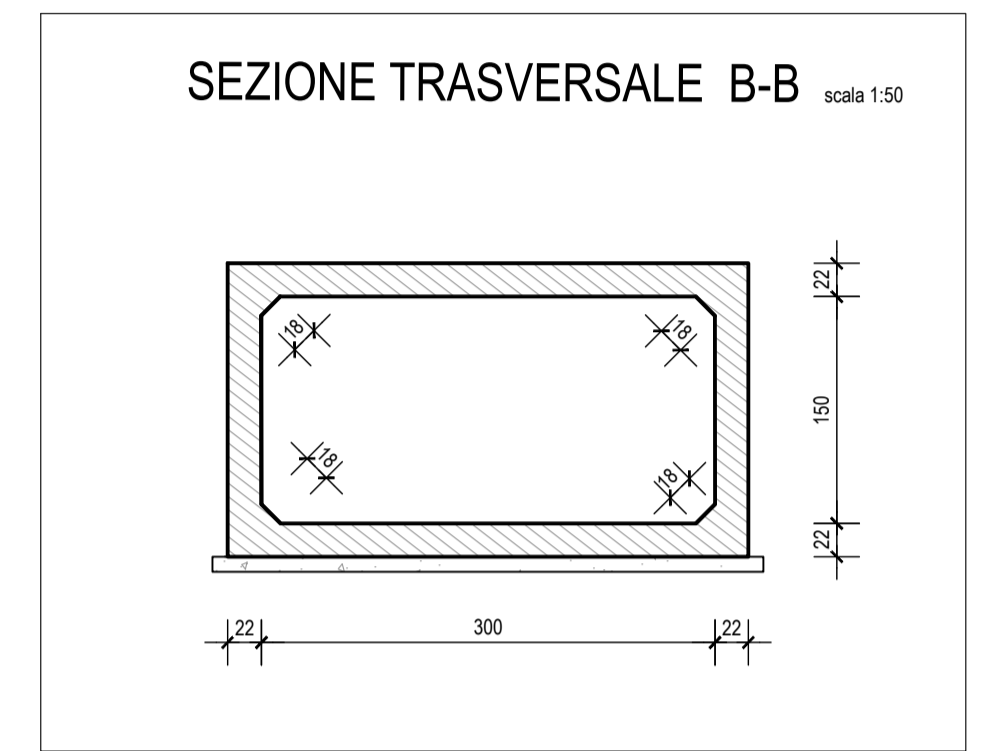

Anas SpA
 Direzione Centrale Progettazione

CUP F2602000340001 CIG 652449686B



GARA CA 08/15 - NUOVA SS 554 CAGLIARITANA
 ADEGUAMENTO DELL'ASSE ATTREZZATO URBANO ED ELIMINAZIONE DELLE INTERSEZIONI A RASO DAL KM 1+500 AL KM 11+850

PROGETTO DEFINITIVO

ASSE STRADALE PRINCIPALE
TOMBINI
TOMBINI IDRAULICI ASSE PRINCIPALE
 Tombino T13 progr.6+054 - Planimetria di progetto e sezioni

CODICE PROGETTO		CODICE ELABORATO				SCALA	DATA
progetto	liv. numero	campo 1	campo 2	campo 3	campo 4	rev	
DPCA06	D 1501	T00	TM01	STR	PP13	B	VARIE 30/11/2019

12.18

CONCORRENTE:



PROGETTISTA INDICATO COSTITUENDO R.T.P.

Capogruppo Mandataria R.T.P.	Mandante	Mandante
		ING. FRANCESCA LEO

RESPONSABILE DELL'INTEGRAZIONE FRA LE PRESTAZIONI SPECIALISTICHE Ing. Paolo Cucino	RESPONSABILE ELABORATO Ing. Paolo Cucino
--	---