

COMMITTENTE:



DIREZIONE LAVORI:



APPALTATORE:
CONSORZIO:



SOCI:



PROGETTAZIONE:
MANDATARIA:



MANDANTI:



PROGETTO ESECUTIVO

ITINERARIO NAPOLI - BARI RADDOPPIO TRATTA APICE - ORSARA I LOTTO FUNZIONALE APICE - HIRPINIA

IMPIANTO LUCE E FORZA MOTRICE

IE11 - FERMATA DI APICE FV02

Particolari d'installazione impianti

APPALTATORE	DIRETTORE DELLA PROGETTAZIONE	PROGETTISTA
Consorzio HIRPINIA AV Il Direttore Tecnico Ing. Vincenzo Moriello 10/06/2020	Il Responsabile integrazione fra le varie prestazioni specialistiche Ing. G. Cassani	Alpina S.p.A. Ing. Paola Erba

COMMESSA LOTTO FASE ENTE TIPO DOC. OPERA/DISCIPLINA PROGR. REV. SCALA:

IF28 01 E ZZ BX LF1100 001 B -

Rev.	Descrizione	Redatto	Data	Verificato	Data	Approvato	Data	Autorizzato Data
A	Emissione per consegna	F. Fantinato	21/02/2020	P. Perrotta	21/02/2020	M. Vernaleone	21/02/2020	Ing. Paola Erba
B	Emissione per istruttoria	F. Fantinato	10/06/2020	P. Perrotta	10/06/2020	M. Vernaleone	10/06/2020	
								10/06/2020

File: IF2801EZZBXL1100001B.dwg

n.Elabor.: 0

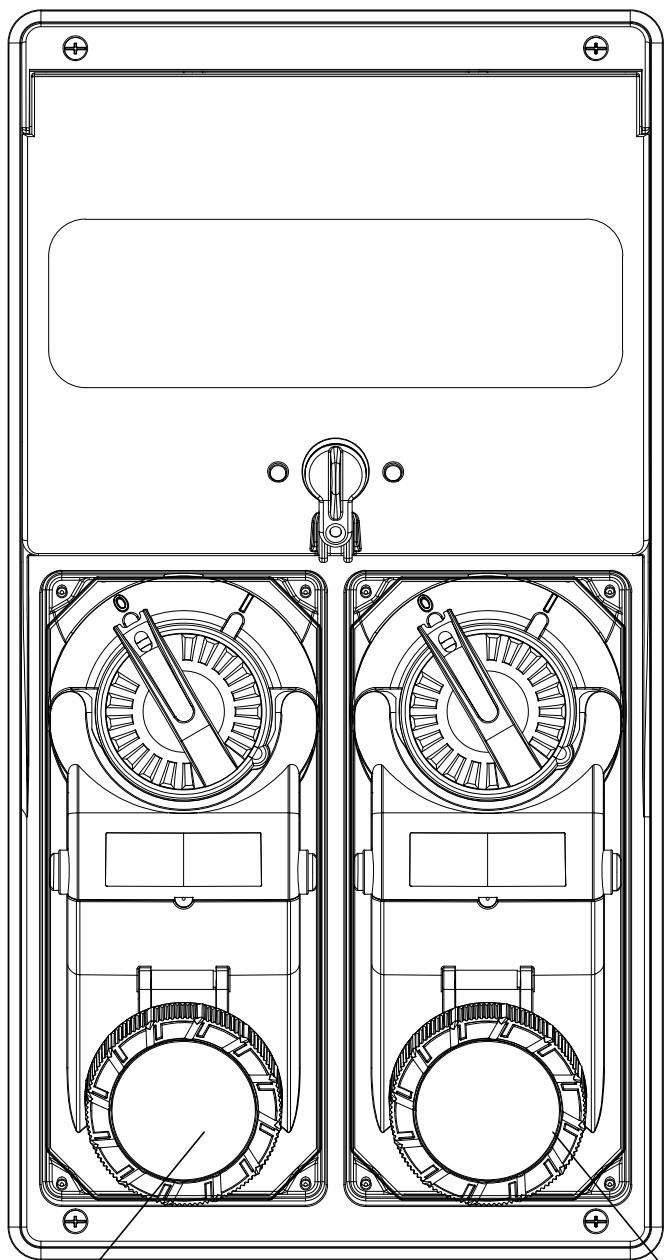

PRESA 3F+T 16 A

PRESA F+N+T 16 A

1 2 3 4 5 6 7 8

A
B
C
D
E
F

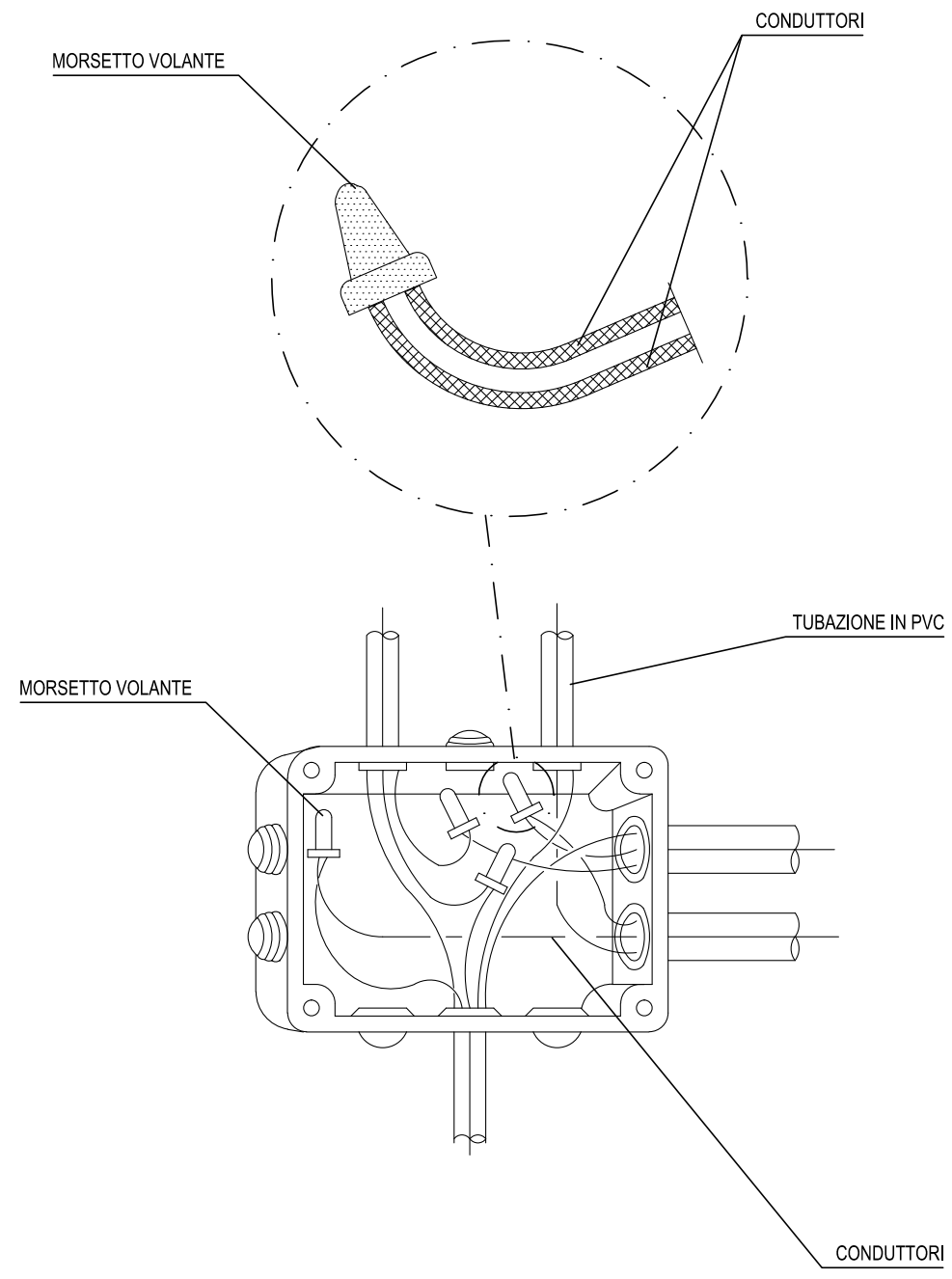

1 2 3 4 5 6 7 8

1 2 3 4 5 6 7 8

A

A

B

B

C

C

D

D

E

E

F

F

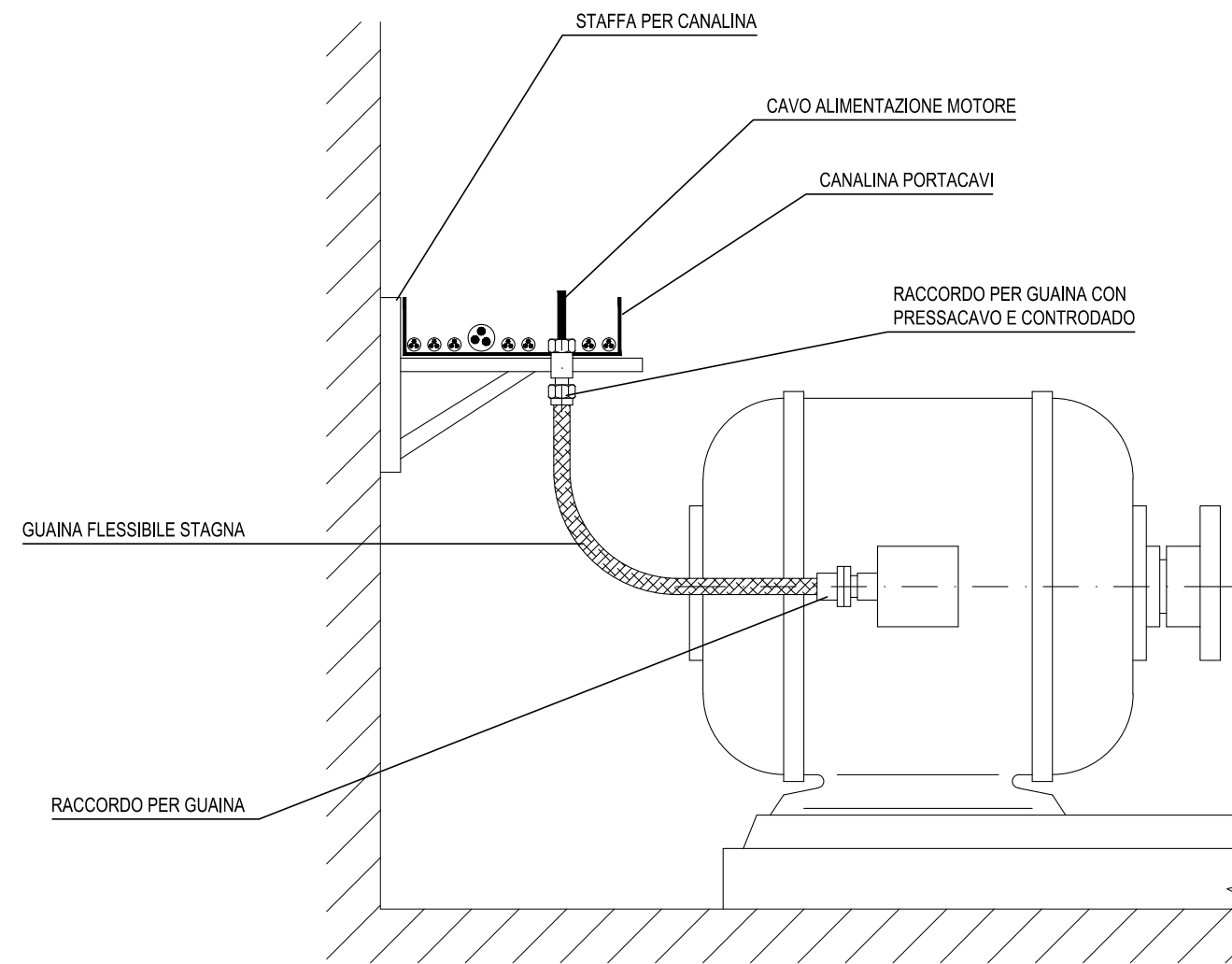

1 2 3 4 5 6 7 8

PUNTO DI COMANDO STAGNO

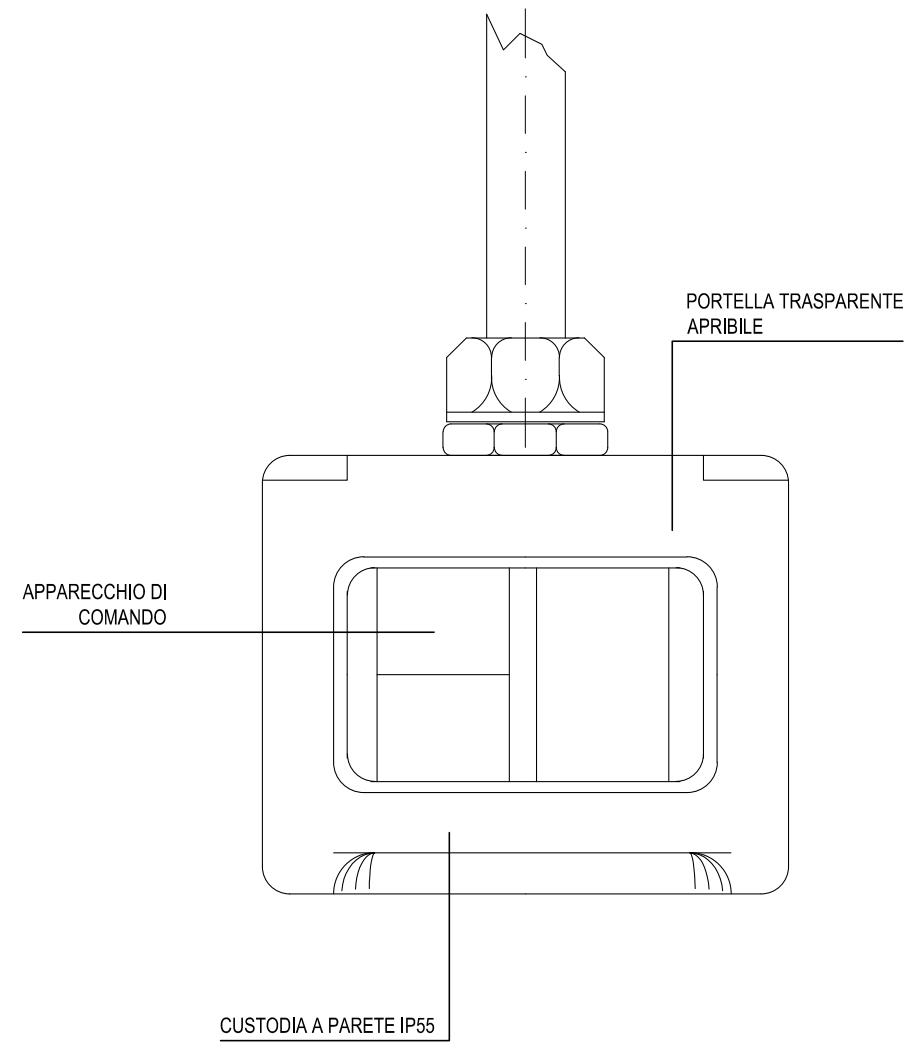

PUNTO DI COMANDO E PRESE

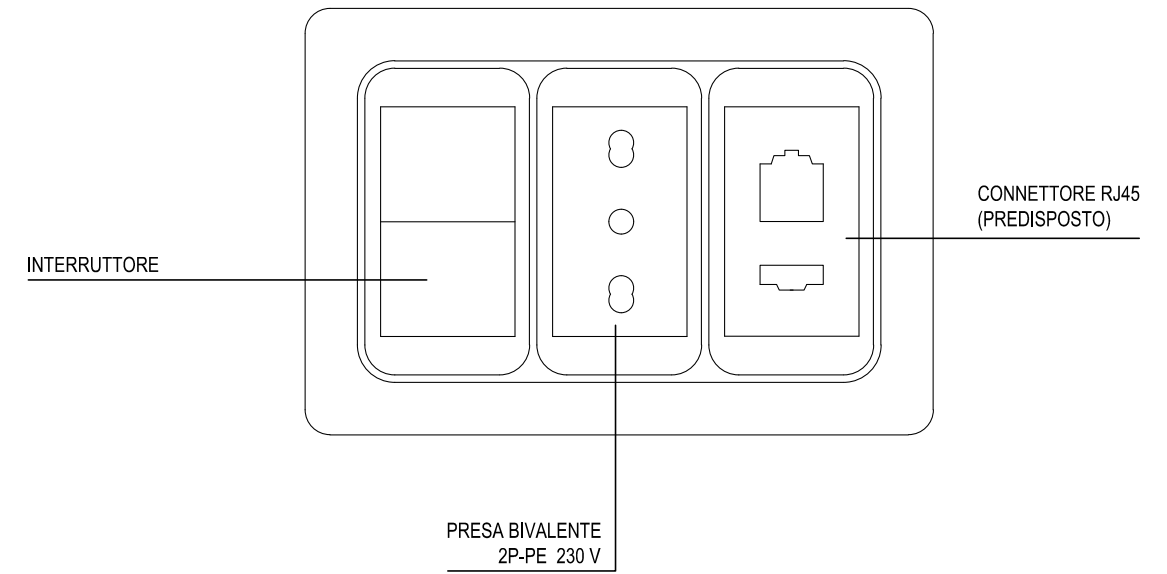

1

2

3

4

5

6

7

8

A

A

B

B

C

C

D

D

E

E

F

F

VETRO FRANGIBILE

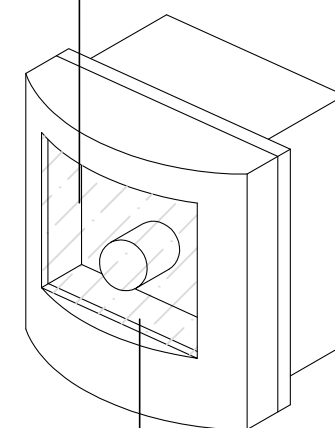

CUSTODIA IN MATERIALE TERMOPLASTICO

1

2

3

4

5

6

7

8

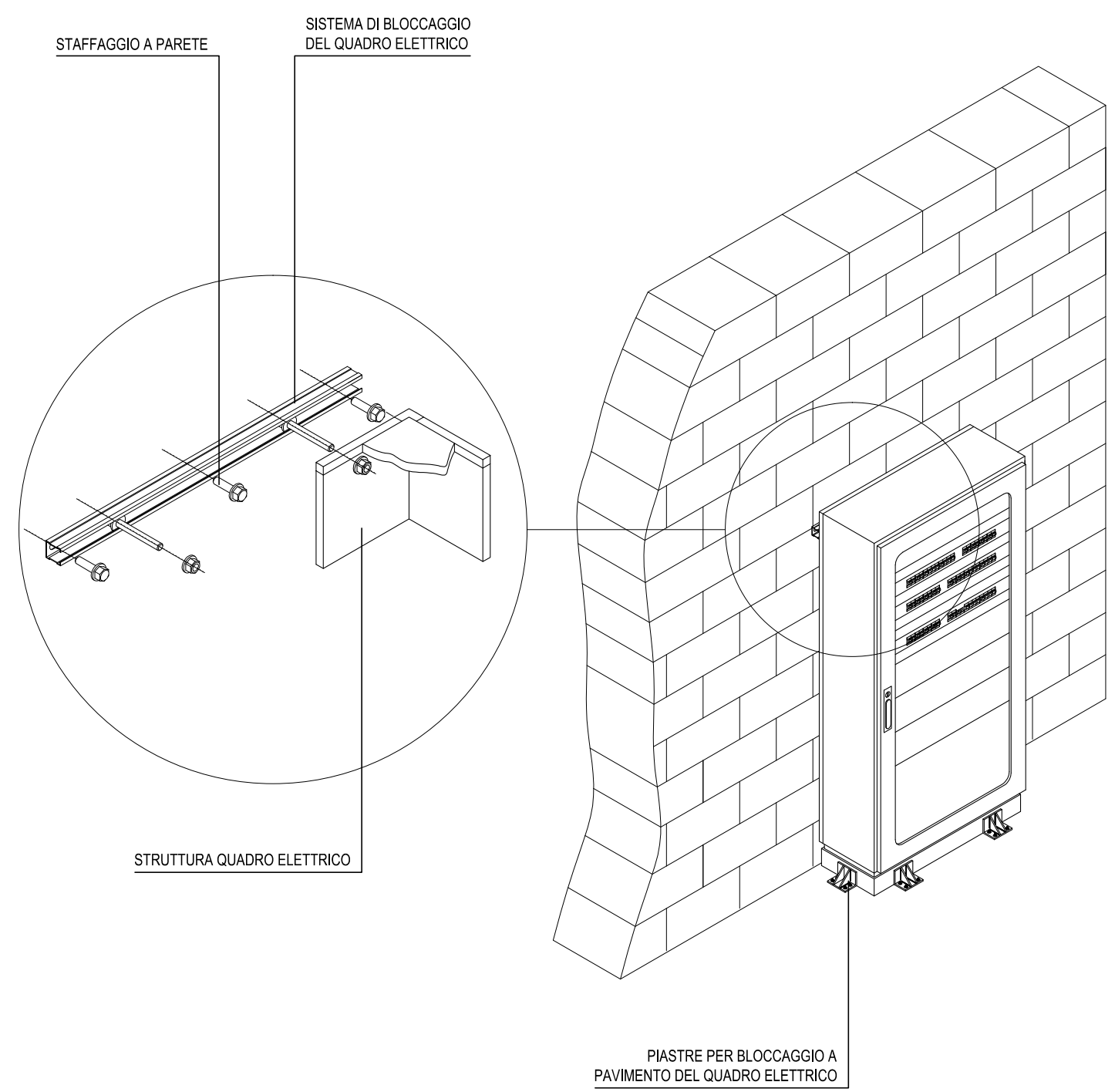

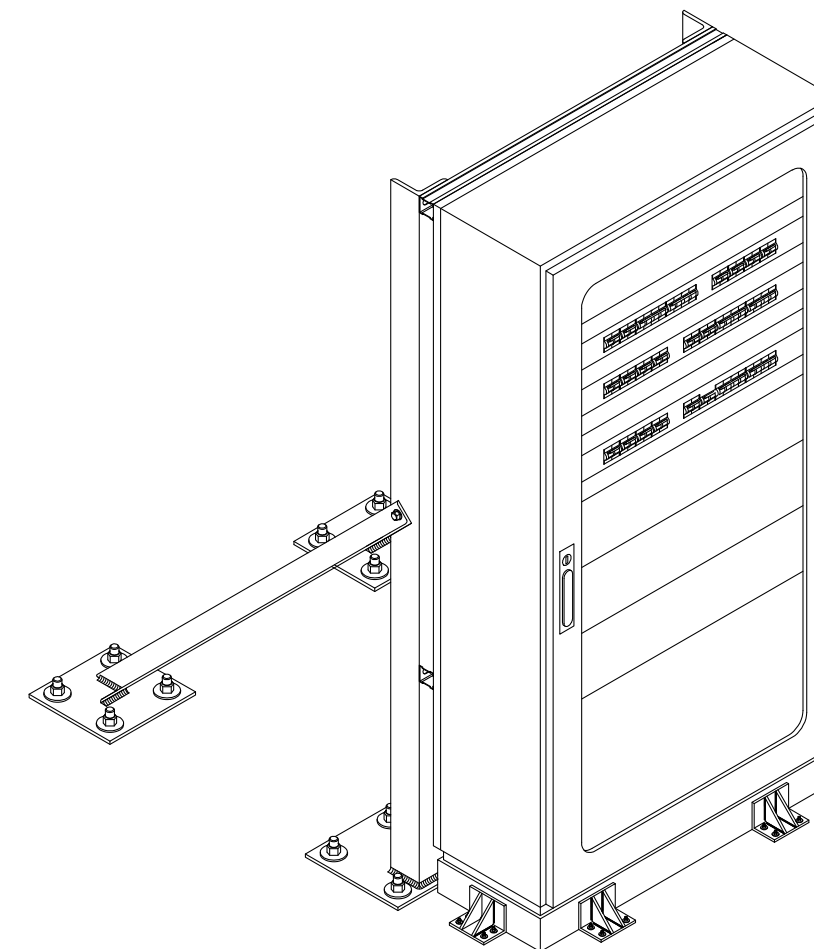
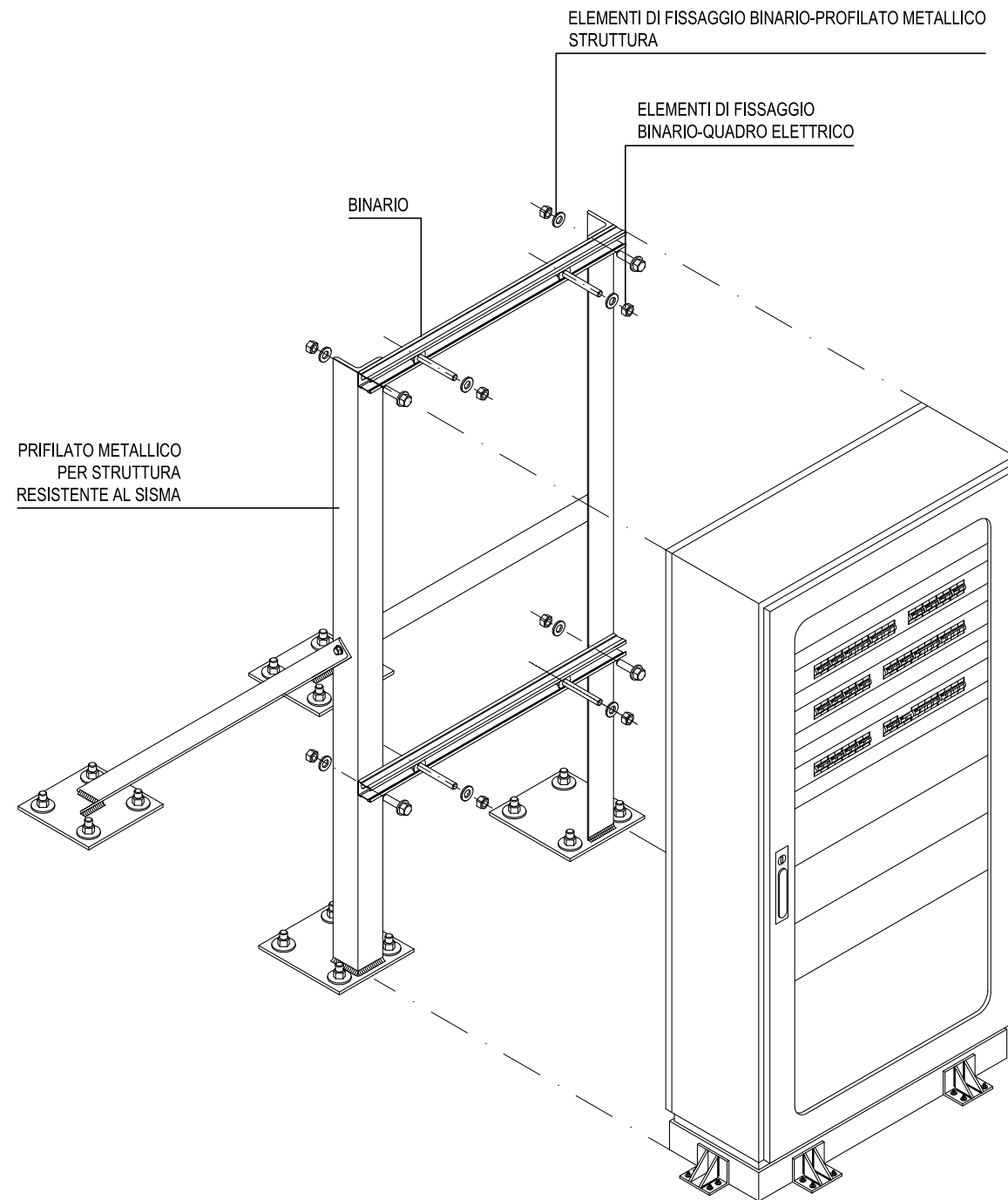

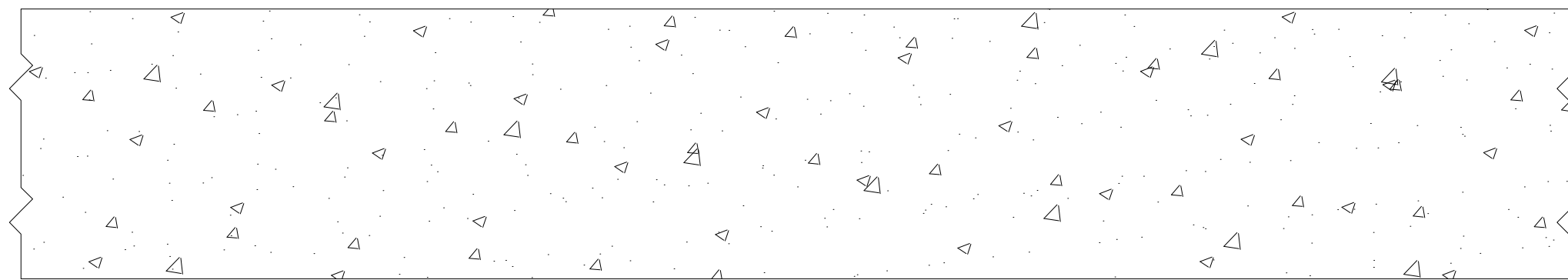

CASSETTA DI DERIVAZIONE

GUAINA DI RACCORDO

PLAFONIERA STAGNA

COLLETTORE

$S \geq S^I, S^{II}, S^{III}, S^{IV}$

ALL'IMPIANTO DI
TERRA GENERALE

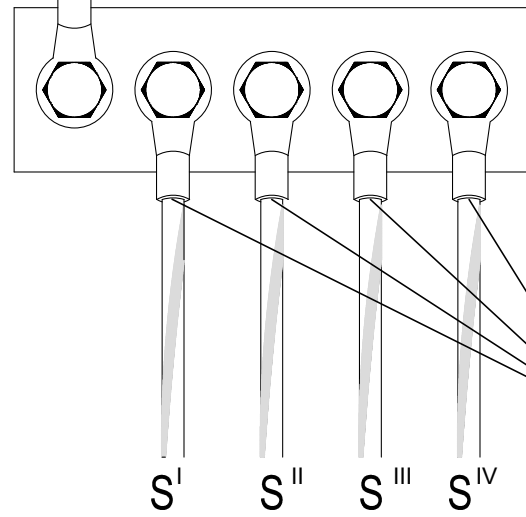

IDENTIFICAZIONE DI ESTREMITÀ
DEGLI EVENTUALI PE DEI CONDUTTORI
DI EQUALIZZAZIONE DEL POTENZIALE
DELLE MASSE ESTRANEE

MORSETTO

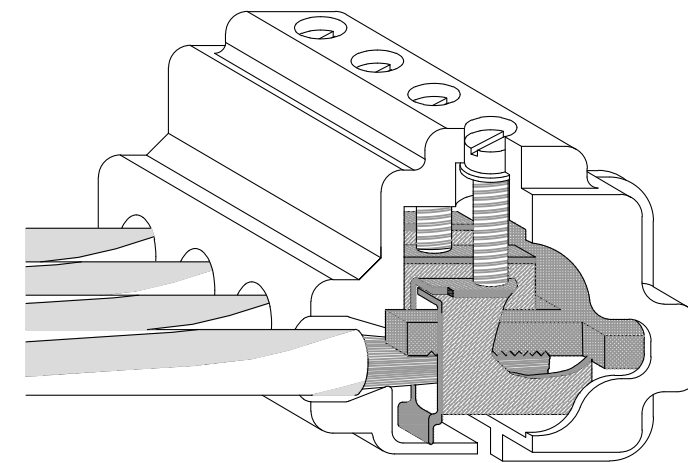

COLLEGAMENTO DI PIU' TUBAZIONI METALLICHE AFFIANCATE
ALL'IMPIANTO DI TERRA

