

COMMITTENTE:



DIREZIONE LAVORI:



APPALTATORE:
CONSORZIO:



SOCI:



PROGETTAZIONE:
MANDATARIA:



MANDANTI:



PROGETTO ESECUTIVO

ITINERARIO NAPOLI - BARI RADDOPPIO TRATTA APICE - ORSARA I LOTTO FUNZIONALE APICE - HIRPINIA

VIADOTTI

VI02 - VIADOTTO UFITA MELITO DA KM 4+827.3 A KM 5+032.3

RELAZIONE DI CALCOLO FONDAZIONI SPALLA A

APPALTATORE	DIRETTORE DELLA PROGETTAZIONE	PROGETTISTA
Consorzio HIRPINIA AV Il Direttore Tecnico Ing. Vincenzo Moriello 10/06/2020	Il Responsabile integrazione fra le varie prestazioni specialistiche Ing. G. Cassani	Alpina S.p.A. Ing. Paolo Galvanin

COMMESSA LOTTO FASE ENTE TIPO DOC. OPERA/DISCIPLINA PROGR. REV. SCALA:

IF28 01 E ZZ CL VI0203 001 B -

Rev.	Descrizione	Redatto	Data	Verificato	Data	Approvato	Data	Autorizzato Data
A	Emissione per consegna	P.Pazzaglia	21/02/2020	L.Zanelotti	21/02/2020	M.Vernaleone	21/02/2020	P.Galvanin 10/06/2020
B	Recepimento Istrutorie	P.Pazzaglia	10/06/2020	L.Zanelotti	10/06/2020	M.Vernaleone	10/06/2020	

File: IF2801EZZCLVI0203001B.doc

n. Elab.:

APPALTATORE: <u>Consorzio</u> HIRPINIA AV	<u>Soci</u> SALINI IMPREGILO S.P.A. ASTALDI S.P.A.	ITINERARIO NAPOLI – BARI RADDOPPIO TRATTA APICE – ORSARA I LOTTO FUNZIONALE APICE – HIRPINIA				
PROGETTAZIONE: <u>Mandatario</u> ROCKSOIL S.P.A.	<u>Mandanti</u> NET ENGINEERING S.P.A. ALPINA S.P.A.					
PROGETTO ESECUTIVO RELAZIONE DI CALCOLO FONDAZIONI SPALLA A	COMMESSA IF28	LOTTO 01	CODIFICA E ZZ CL	DOCUMENTO VI0203 001	REV. B	FOGLIO 2 di 109

Indice

1	INTRODUZIONE	4
2	DOCUMENTI DI RIFERIMENTO E NORMATIVA.....	5
2.1	DOCUMENTI DI RIFERIMENTO.....	5
2.2	NORMATIVA E STRANDARD DI RIFERIMENTO	5
2.3	SOFTWARE	6
3	MATERIALI.....	7
3.1	ACCIAIO	7
3.1.1	ACCIAIO PER ARMATURA STRUTTURE IN C.A.	7
3.1.2	PROFILATI E PIASTRE METALLICHE	7
3.2	CALCESTRUZZO.....	7
3.2.1	CALCESTRUZZO MAGRO PER GETTI DI LIVELLAMENTO	7
3.2.2	CALCESTRUZZO PALI, DIAFRAMMI DI FONDAZIONE, CORDOLI E OPERE PROVVISORIALI	7
3.2.3	CALCESTRUZZO PER FONDAZIONI PILE E SPALLE	7
4	DESCRIZIONE DELLE FONDAZIONI E STRATIGRAFIA DI PROGETTO	9
4.1	DESCRIZIONE DEL SISTEMA FONDAZIONALE	9
4.2	STRATIGRAFIA DI RIFERIMENTO.....	9
5	CRITERI DI VERIFICA.....	10
6	SCARICHI DI FONDAZIONE	11
6.1	SCARICHI ALLA BASE DEL PLINTO	11
6.1.1	COMBINAZIONI DELLE AZIONI AGLI STATI LIMITE ULTIMI SISMICI.....	11
6.1.2	COMBINAZIONI DELLE AZIONI AGLI STATI LIMITE ULTIMI STATICI (SLU)	12
6.1.3	COMBINAZIONI DELLE AZIONI AGLI STATI LIMITE DI ESERCIZIO (SLE).....	13
6.2	SCARICHI A INTRADOSSO PLINTO - GROUP	13
6.2.1	COMBINAZIONI DELLE AZIONI AGLI STATI LIMITE ULTIMI SISMICI (SLV).....	13
6.2.2	COMBINAZIONI DELLE AZIONI AGLI STATI LIMITE ULTIMI STATICI (SLU)	14
6.2.3	COMBINAZIONI DELLE AZIONI AGLI STATI LIMITE DI ESERCIZIO (SLE).....	15
7	ANALISI DELL'INTERAZIONE FONDAZIONE-TERRENO	16
7.1	DESCRIZIONE DEL MODELLO DI CALCOLO GROUP	16
7.2	SINTESI DEI RISULTATI AGLI STATI LIMITE DI ESERCIZIO (SLE)	20
7.3	SINTESI DEI RISULTATI AGLI STATI LIMITE ULTIMI STATICI (SLU)	23
7.4	SINTESI DEI RISULTATI AGLI STATI LIMITE ULTIMI SISMICI (SLV).....	25

APPALTATORE: Consorzio Soci   	ITINERARIO NAPOLI – BARI RADDOPPIO TRATTA APICE – ORSARA I LOTTO FUNZIONALE APICE – HIRPINIA																	
PROGETTAZIONE: Mandataria Mandanti   	<table border="1" style="width: 100%; border-collapse: collapse;"> <tr> <td style="width: 16.6%;">COMMESSA</td> <td style="width: 16.6%;">LOTTO</td> <td style="width: 16.6%;">CODIFICA</td> <td style="width: 16.6%;">DOCUMENTO</td> <td style="width: 16.6%;">REV.</td> <td style="width: 16.6%;">FOGLIO</td> </tr> <tr> <td style="text-align: center;">IF1N</td> <td style="text-align: center;">01 E ZZ</td> <td style="text-align: center;">RG</td> <td style="text-align: center;">MD0000 001</td> <td style="text-align: center;">B</td> <td style="text-align: center;">3 di 109</td> </tr> </table>						COMMESSA	LOTTO	CODIFICA	DOCUMENTO	REV.	FOGLIO	IF1N	01 E ZZ	RG	MD0000 001	B	3 di 109
COMMESSA	LOTTO	CODIFICA	DOCUMENTO	REV.	FOGLIO													
IF1N	01 E ZZ	RG	MD0000 001	B	3 di 109													
PROGETTO ESECUTIVO RELAZIONE DI CALCOLO FONDAZIONI SPALLA A																		

8	VERIFICA DEI PALI DI FONDAZIONE	28
9	VERIFICHE ALLO SLU DI TIPO GEOTECNICO	35
9.1	VERIFICA DI CAPACITÀ PORTANTE DEL PALO SINGOLO	35
9.1.1	CAPACITÀ PORTANTE VERTICALE DEL PALO SINGOLO	35
9.1.2	VERIFICA DI CAPACITÀ PORTANTE VERTICALE DEL GRUPPO DI PALI.....	40
9.1.1	VERIFICA DI CAPACITÀ PORTANTE ORIZZONTALE DEL GRUPPO DI PALI	41

APPALTATORE: <u>Consorzio</u> <u>Soci</u> HIRPINIA AV SALINI IMPREGILO S.P.A. ASTALDI S.P.A	ITINERARIO NAPOLI – BARI RADDOPPIO TRATTA APICE – ORSARA I LOTTO FUNZIONALE APICE – HIRPINIA																	
PROGETTAZIONE: <u>Mandatario</u> <u>Mandanti</u> ROCKSOIL S.P.A NET ENGINEERING S.P.A. ALPINA S.P.A.	<table border="1" style="width: 100%; border-collapse: collapse;"> <tr> <td style="text-align: center;">COMMESSA</td> <td style="text-align: center;">LOTTO</td> <td style="text-align: center;">CODIFICA</td> <td style="text-align: center;">DOCUMENTO</td> <td style="text-align: center;">REV.</td> <td style="text-align: center;">FOGLIO</td> </tr> <tr> <td style="text-align: center;">IF28</td> <td style="text-align: center;">01</td> <td style="text-align: center;">E ZZ CL</td> <td style="text-align: center;">VI0203 001</td> <td style="text-align: center;">B</td> <td style="text-align: center;">4 di 109</td> </tr> </table>						COMMESSA	LOTTO	CODIFICA	DOCUMENTO	REV.	FOGLIO	IF28	01	E ZZ CL	VI0203 001	B	4 di 109
COMMESSA	LOTTO	CODIFICA	DOCUMENTO	REV.	FOGLIO													
IF28	01	E ZZ CL	VI0203 001	B	4 di 109													
PROGETTO ESECUTIVO RELAZIONE DI CALCOLO FONDAZIONI SPALLA A																		

1 INTRODUZIONE

Nell'ambito della redazione del Progetto Esecutivo della tratta Apice - Orsara del Lotto 1 Apice – Irpinia - potenziamento della linea ferroviaria Napoli – Bari, la presente relazione riporta i risultati del dimensionamento e verifiche delle fondazioni della spalla SPA del Viadotto VI02 denominato Viadotto Ufita Melito.

Per quanto riguarda i criteri di verifica adottati per le analisi del sistema di fondazione adottato si rimanda al documento IF2801EZZRBVI0003001: Viadotti ferroviari – Relazione sui criteri di calcolo delle fondazioni.

APPALTATORE: Consorzio Soci   	ITINERARIO NAPOLI – BARI RADDOPPIO TRATTA APICE – ORSARA I LOTTO FUNZIONALE APICE – HIRPINIA																	
PROGETTAZIONE: Mandataria Mandanti   	<table border="1" style="width: 100%; border-collapse: collapse;"> <tr> <td style="width: 16.6%;">COMMESSA</td> <td style="width: 16.6%;">LOTTO</td> <td style="width: 16.6%;">CODIFICA</td> <td style="width: 16.6%;">DOCUMENTO</td> <td style="width: 16.6%;">REV.</td> <td style="width: 16.6%;">FOGLIO</td> </tr> <tr> <td>IF1N</td> <td>01 E ZZ</td> <td>RG</td> <td>MD0000 001</td> <td>B</td> <td>5 di 109</td> </tr> </table>						COMMESSA	LOTTO	CODIFICA	DOCUMENTO	REV.	FOGLIO	IF1N	01 E ZZ	RG	MD0000 001	B	5 di 109
COMMESSA	LOTTO	CODIFICA	DOCUMENTO	REV.	FOGLIO													
IF1N	01 E ZZ	RG	MD0000 001	B	5 di 109													
PROGETTO ESECUTIVO RELAZIONE DI CALCOLO FONDAZIONI SPALLA A																		

2 Documenti di riferimento e normativa

2.1 DOCUMENTI DI RIFERIMENTO

- 1) IF2801EZZRGVI0000001 - Relazione Tecnico-Descrittiva delle Opere Civili - Viadotti VI01, VI02, VI03 e VI04;
- 2) IF2801EZZRBVI0003001 - Relazione sui criteri di calcolo delle fondazioni;
- 3) IF2801EZZRBOC0101001 - Relazione Geotecnica Generale;
- 4) IF2801EZZF6OC0101001 - Profilo geologico - Tratta all'aperto Isca Girasole, da pk 0+000 a 2+705;
- 5) IF2801EZZF6OC0101002 - Profilo geologico - Tratta all'aperto valle Ufita, da pk 4+695 a pk 5+090;
- 6) IF2801EZZF6OC0101003 - Profilo geologico - Tratta all'aperto Castel del Fiego, da pk 9+550 a pk 10+090;
- 7) IF2801EZZF6OC0101004 - Profilo geologico - Tratta all'aperto Iscalonga, da pk 16+610 a pk 18+700;
- 8) IF2801EZZRBOC0301001 - Relazione Sismica generale;
- 9) IF2801EZZP9VI0200000 - Pianta fondazioni e sezioni (tav. 1 di 2);
- 10) IF2801EZZP9VI0200001 - Pianta fondazioni e sezioni (tav. 2 di 2);
- 11) IF2801EZZP9VI0200002 - Pianta impalcato e prospetto (tav. 1 di 2);
- 12) IF2801EZZP9VI0200003 - Pianta impalcato e prospetto (tav. 2 di 2);
- 13) IF2801EZZCLVI0204001 - Spalla A: Relazione di calcolo strutture in elevazione;
- 14) IF2801EZZCLVI0205002 - Pile P1: Relazione di calcolo strutture in elevazione;
- 15) IF2801EZZCLVI0205003 - Pila P2: Relazione di calcolo strutture in elevazione;
- 16) IF2801EZZCLVI0205004 - Pila P3: Relazione di calcolo strutture in elevazione;
- 17) IF2801EZZCLVI0205005 - Pile P4: Relazione di calcolo strutture in elevazione;
- 18) IF2801EZZCLVI0204002 - Spalla B : Relazione di calcolo strutture in elevazione;
- 19) IF2801EZZCLVI0203001 - Relazione di calcolo fondazioni spalla A;
- 20) IF2801EZZCLVI0203002 - Relazione di calcolo fondazioni pila P1;
- 21) IF2801EZZCLVI0203003 - Relazione di calcolo fondazioni pile P2 e P3;
- 22) IF2801EZZCLVI0203004 - Relazione di calcolo fondazioni pile P4 e spalla B.

2.2 NORMATIVA E STRANDARD DI RIFERIMENTO

- 23) Decreto Ministeriale del 14/01/2008: "Approvazione delle Nuove Norma Tecniche per le Costruzioni", G.U. n.29 del 04/02/2008, Supplemento Ordinario n.30;
- 24) Circolare 01/02/2009, n.617 - Istruzione per l'applicazione delle "Nuove Norme Tecniche per le Costruzioni" di cui al D.M. 14/01/2008;

APPALTATORE: Consorzio Soci   	ITINERARIO NAPOLI – BARI RADDOPPIO TRATTA APICE – ORSARA I LOTTO FUNZIONALE APICE – HIRPINIA																	
PROGETTAZIONE: Mandataria Mandanti   	<table border="1" style="width: 100%; border-collapse: collapse;"> <tr> <td style="width: 16.6%;">COMMESSA</td> <td style="width: 16.6%;">LOTTO</td> <td style="width: 16.6%;">CODIFICA</td> <td style="width: 16.6%;">DOCUMENTO</td> <td style="width: 16.6%;">REV.</td> <td style="width: 16.6%;">FOGLIO</td> </tr> <tr> <td>IF1N</td> <td>01 E ZZ</td> <td>RG</td> <td>MD0000 001</td> <td>B</td> <td>6 di 109</td> </tr> </table>						COMMESSA	LOTTO	CODIFICA	DOCUMENTO	REV.	FOGLIO	IF1N	01 E ZZ	RG	MD0000 001	B	6 di 109
COMMESSA	LOTTO	CODIFICA	DOCUMENTO	REV.	FOGLIO													
IF1N	01 E ZZ	RG	MD0000 001	B	6 di 109													
PROGETTO ESECUTIVO RELAZIONE DI CALCOLO FONDAZIONI SPALLA A																		

- 25) DM 06/05/2008 - "Integrazione al DM 14/01/2008 di approvazione delle Nuove Norme Tecniche per le Costruzioni";
- 26) RFI DTC SI MA IFS 001 A - "Manuale di progettazione delle opere civili";
- 27) RFI DTC SI SP IFS 001 A - "Capitolato generale tecnico d'appalto delle opere civili";
- 28) UNI EN 1997-1: Eurocodice 7 - Progettazione Geotecnica - Parte 1: Regole generali;
- 29) UNI EN 1998-5: Eurocodice 8 - Progettazione delle strutture per la resistenza sismica - Parte 5: Fondazioni, strutture di contenimento ed aspetti geotecnici;
- 30) Caltrans. Guidelines on Foundation Loading and Deformation Due to Liquefaction Induced Lateral Spreading. California Department of Transportation, Sacramento, California, 2012;
- 31) JRA (2002) – Specifications for Highway Bridges, JapanRoad Association. Part V: Seismic Design.

2.3 SOFTWARE

- 32) Lpile, Ensoft Inc, versione 2016, release n. 9;
- 33) Group, Ensoft Inc, versione 2016, release n.10;
- 34) GeoStru, RC-SEC, Calcolo di sezioni in Cemento Armato;
- 35) Pozzi J – Pozzi di fondazione o di stabilizzazione – VOL. 4, T. Collotta 2010.

APPALTATORE: Consorzio Soci   	ITINERARIO NAPOLI – BARI RADDOPPIO TRATTA APICE – ORSARA I LOTTO FUNZIONALE APICE – HIRPINIA																	
PROGETTAZIONE: Mandataria Mandanti   	<table border="1" style="width: 100%; border-collapse: collapse;"> <tr> <td style="width: 16.6%;">COMMESSA</td> <td style="width: 16.6%;">LOTTO</td> <td style="width: 16.6%;">CODIFICA</td> <td style="width: 16.6%;">DOCUMENTO</td> <td style="width: 16.6%;">REV.</td> <td style="width: 16.6%;">FOGLIO</td> </tr> <tr> <td>IF1N</td> <td>01 E ZZ</td> <td>RG</td> <td>MD0000 001</td> <td>B</td> <td>7 di 109</td> </tr> </table>						COMMESSA	LOTTO	CODIFICA	DOCUMENTO	REV.	FOGLIO	IF1N	01 E ZZ	RG	MD0000 001	B	7 di 109
COMMESSA	LOTTO	CODIFICA	DOCUMENTO	REV.	FOGLIO													
IF1N	01 E ZZ	RG	MD0000 001	B	7 di 109													
PROGETTO ESECUTIVO RELAZIONE DI CALCOLO FONDAZIONI SPALLA A																		

3 Materiali

Il progetto strutturale delle fondazioni prevede l'uso dei materiali con le caratteristiche meccaniche minime riportate nei paragrafi seguenti.

3.1 ACCIAIO

3.1.1 Acciaio per armatura strutture in c.a.

Barre ad aderenza migliorata, saldabile, tipo B450C dotato delle seguenti caratteristiche meccaniche:

- tensione caratteristica di rottura: $f_{tk} \geq 540 \text{ MPa}$
- tensione caratteristica di snervamento: $f_{yk} \geq 450 \text{ MPa}$
- allungamento caratteristico: $\geq 7.5 \%$
- rapporto tensione di rottura/ tensione di snervamento: $1.15 \leq f_{tk}/f_{yk} < 1.35$

3.1.2 Profilati e piastre metalliche

- - Acciaio tipo: EN 10025-S275 JR
- - Tensione di rottura a trazione: $f_{tk} \geq 430 \text{ MPa}$
- - Tensione di snervamento: $f_{yk} \geq 275 \text{ MPa}$

3.2 CALCESTRUZZO

3.2.1 Calcestruzzo magro per getti di livellamento

- Classe di resistenza: C12/15
- classe di esposizione: X0

3.2.2 Calcestruzzo pali, diaframmi di fondazione, cordoli e opere provvisionali

- Classe di resistenza: C25/30
- classe di consistenza: S4
- classe di esposizione: XC2
- dimensione massima dell'inerte: $D_{max} = 32 \text{ mm}$
- copriferro minimo: $C_{f,min} \geq 60 \text{ mm}$

3.2.3 Calcestruzzo per fondazioni pile e spalle

- Classe di resistenza: C28/35
- classe di consistenza: S4
- classe di esposizione: XC2

APPALTATORE: Consorzio Soci   	ITINERARIO NAPOLI – BARI RADDOPPIO TRATTA APICE – ORSARA I LOTTO FUNZIONALE APICE – HIRPINIA																	
PROGETTAZIONE: Mandataria Mandanti   	<table border="1" style="width: 100%; border-collapse: collapse;"> <tr> <td style="width: 16.6%;">COMMESSA</td> <td style="width: 16.6%;">LOTTO</td> <td style="width: 16.6%;">CODIFICA</td> <td style="width: 16.6%;">DOCUMENTO</td> <td style="width: 16.6%;">REV.</td> <td style="width: 16.6%;">FOGLIO</td> </tr> <tr> <td style="text-align: center;">IF1N</td> <td style="text-align: center;">01 E ZZ</td> <td style="text-align: center;">RG</td> <td style="text-align: center;">MD0000 001</td> <td style="text-align: center;">B</td> <td style="text-align: center;">8 di 109</td> </tr> </table>						COMMESSA	LOTTO	CODIFICA	DOCUMENTO	REV.	FOGLIO	IF1N	01 E ZZ	RG	MD0000 001	B	8 di 109
COMMESSA	LOTTO	CODIFICA	DOCUMENTO	REV.	FOGLIO													
IF1N	01 E ZZ	RG	MD0000 001	B	8 di 109													
PROGETTO ESECUTIVO RELAZIONE DI CALCOLO FONDAZIONI SPALLA A																		

- dimensione massima dell'inerte:
 $D_{max} = 25 \text{ mm}$
- copriferro minimo:
 $C_{f,min} \geq 40 \text{ mm}$

APPALTATORE: Consorzio Soci   	ITINERARIO NAPOLI – BARI RADDOPPIO TRATTA APICE – ORSARA I LOTTO FUNZIONALE APICE – HIRPINIA					
PROGETTAZIONE: Mandataria Mandanti   						
PROGETTO ESECUTIVO RELAZIONE DI CALCOLO FONDAZIONI SPALLA A	COMMESSA IF1N	LOTTO 01 E ZZ	CODIFICA RG	DOCUMENTO MD0000 001	REV. B	FOGLIO 9 di 109

4 DESCRIZIONE DELLE FONDAZIONI E STRATIGRAFIA DI PROGETTO

4.1 DESCRIZIONE DEL SISTEMA FONDAZIONALE

La fondazione della spalla SPA è costituita da: un plinto a sezione rettangolare di dimensioni 12.0 m x 21.0 m² e altezza di 2.0 m; su n.15 pali trivellati di diametro $\varnothing = 1500$ mm e lunghezza L = 22.0 m.

4.2 STRATIGRAFIA DI RIFERIMENTO

In accordo con quanto riportato nella Relazione Geotecnica Generale - ref. 3), la stratigrafia e i parametri geotecnici di riferimento sono riportati nella seguente Tabella 1 unitamente alla portanza limite laterale e di base dei diaframmi.

La quota piano campagna di riferimento è ca. 295.50 m s.l.m.. Si considera la profondità della testa del palo da p.c. di ca. 5 m.

STRATIGRAFIA da p.c.				PARAMETRI GEOTECNICI DI RIFERIMENTO			PORTANZA LIMITE DEGLI ELEMENTI FONDAZIONE	
DA	A	ΔH	UNITA' DI RIFERIMENTO	γ	φ	Cu	qs	qb
[m]	[m]	[m]		[kN/m ³]	[°]	[kPa]	[kPa]	[kPa]
0	16	16	depositi franosi	20		120	20.0	
16	26	10	FYR	22		250	118.60	3354.1
26	FYR	22		350	140.30	3968.6

Tabella 1 Stratigrafia e parametri geotecnici di riferimento

La falda è assunta coincidente con la quota testa palo.

APPALTATORE: Consorzio Soci   	ITINERARIO NAPOLI – BARI RADDOPPIO TRATTA APICE – ORSARA I LOTTO FUNZIONALE APICE – HIRPINIA																	
PROGETTAZIONE: Mandataria Mandanti   	<table border="1" style="width: 100%; border-collapse: collapse;"> <tr> <td style="width: 16.6%;">COMMESSA</td> <td style="width: 16.6%;">LOTTO</td> <td style="width: 16.6%;">CODIFICA</td> <td style="width: 16.6%;">DOCUMENTO</td> <td style="width: 16.6%;">REV.</td> <td style="width: 16.6%;">FOGLIO</td> </tr> <tr> <td style="text-align: center;">IF1N</td> <td style="text-align: center;">01 E ZZ</td> <td style="text-align: center;">RG</td> <td style="text-align: center;">MD0000 001</td> <td style="text-align: center;">B</td> <td style="text-align: center;">10 di 109</td> </tr> </table>						COMMESSA	LOTTO	CODIFICA	DOCUMENTO	REV.	FOGLIO	IF1N	01 E ZZ	RG	MD0000 001	B	10 di 109
COMMESSA	LOTTO	CODIFICA	DOCUMENTO	REV.	FOGLIO													
IF1N	01 E ZZ	RG	MD0000 001	B	10 di 109													
PROGETTO ESECUTIVO RELAZIONE DI CALCOLO FONDAZIONI SPALLA A																		

5 CRITERI DI VERIFICA

Per ogni stato limite ultimo deve essere rispettata la condizione:

$$Ed \leq Rd;$$

dove Ed è il valore di progetto dell'azione o dell'effetto dell'azione e Rd è il valore di progetto della resistenza.

Le verifiche sono sviluppate secondo l'approccio 2:

combinazione: A1+M1+R3,

in cui è previsto un'unica combinazione di gruppi di coefficienti, da adottare sia nelle verifiche strutturali (STR) sia nelle verifiche geotecniche (GEO).

Per maggiori dettagli sui criteri di calcolo e verifica si rimanda alla relazione ref. 2).

Per le verifiche a fessurazione si ricorda che sono svolte per condizioni ambientali ordinarie e armature poco sensibili (vedasi § 9.3.1 di ref. 2)).

APPALTATORE: Consorzio Soci 	ITINERARIO NAPOLI – BARI RADDOPPIO TRATTA APICE – ORSARA I LOTTO FUNZIONALE APICE – HIRPINIA					
PROGETTAZIONE: Mandataria Mandanti 						
PROGETTO ESECUTIVO RELAZIONE DI CALCOLO FONDAZIONI SPALLA A	COMMESSA IF1N	LOTTO 01 E ZZ	CODIFICA RG	DOCUMENTO MD0000 001	REV. B	FOGLIO 11 di 109

6 SCARICHI DI FONDAZIONE

Di seguito si esaminano gli scarichi a quota intradosso fondazione della spalla per le combinazioni di carico sismiche (SLV), statiche (SLU) e di esercizio (SLE).

6.1 SCARICHI ALLA BASE DEL PLINTO

Nella Figura 6-1 la convenzione dei segni assunta per il calcolo della spalla.

Le convenzioni:

- X: direzione longitudinale impalcato;
- Y: direzione trasversale impalcato;
- Z: direzione verticale (positiva verso l'alto);
- MX: Momento attorno all'asse X;
- MY: Momento attorno all'asse Y;
- MZ: Momento attorno all'asse Z.



Figura 6-1: Sistema di riferimento proprio della spalla A

6.1.1 Combinazioni delle azioni agli stati limite ultimi sismici

Nella seguente Tabella 2 si riportano le combinazioni di carico più gravose agli stati limite ultimi (SLV) in presenza di sisma.

Tali carichi sono stati ottenuti considerando la struttura in elevazione in classe di duttilità B (fattore di struttura $q=1.5$). Per il dimensionamento e le verifiche del sistema fondazione le azioni da considerare sono le resistenze

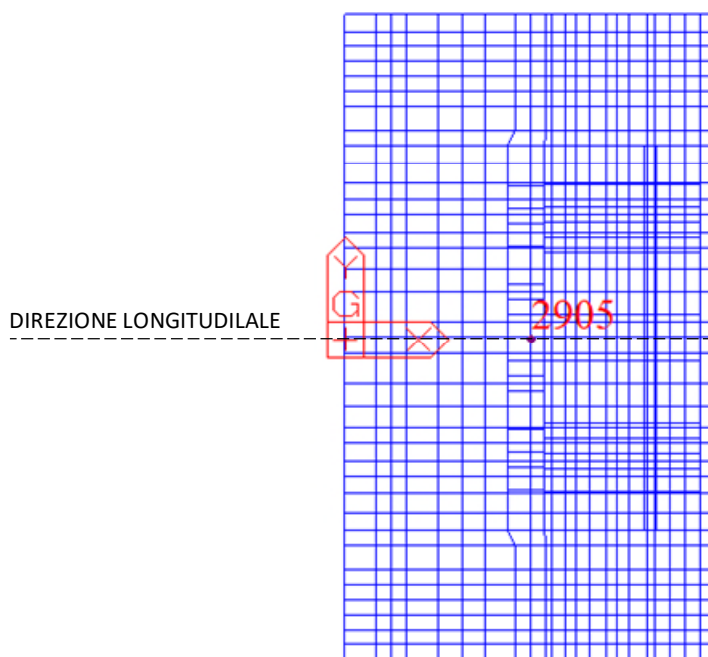
APPALTATORE: Consorzio  Soci  	ITINERARIO NAPOLI – BARI RADDOPPIO TRATTA APICE – ORSARA I LOTTO FUNZIONALE APICE – HIRPINIA
PROGETTAZIONE: Mandataria  Mandanti  	
PROGETTO ESECUTIVO RELAZIONE DI CALCOLO FONDAZIONI SPALLA A	COMMESSA LOTTO CODIFICA DOCUMENTO REV. FOGLIO IF1N 01 E ZZ RG MD0000 001 B 12 di 109

degli elementi strutturali soprastanti, con il limite, in accordo alle NTC 2008 (ref. 23)), che il fattore di amplificazione non superi $\gamma_{Rd} = 1.1$.

COMB SISMICHE SLV

Node	Load	FX (kN)	FY (kN)	FZ (kN)	MX (kN*m)	MY (kN*m)	MZ (kN*m)
*****	*****	*****	*****	*****	*****	*****	*****
2905	ULS_V_02	12424.1	-81.5	-28788.4	793.0	52148.3	-1.1
2905	ULS_V_05	-21457.5	-81.5	-28735.6	793.0	-55554.8	-26.4
2905	ULS_V_09	-3007	14975.2	-28736	-53173	3968	7861
2905	ULS_V_14	-3007	-15138.2	-28736	54759	3968	-7886
2905	ULS_V_30	-3007	-4598	-23761.4	16978	1367	-2375
2905	ULS_V_19	2476	-81	-38026.1	802	27182	-11
2905	ULS_V_15	-3007	-15138	-32999	54762.896	6197	-7886
2905	ULS_V_10	-3007	14975	-28736	-53172.740	3968	7861
2905	ULS_V_04	12424	-81	-33052	797	54377.8	-1
2905	ULS_V_05	-21458	-81	-28736	793	-55554.8	-26
2905	ULS_V_09	-3007	14975	-28736	-53173	3968	7861.2
2905	ULS_V_16	-3007	-15138	-32999	54763	6197	-7886.2

Tabella 2: Combinazioni sismiche SLV: azioni agenti a base spalla



6.1.2 Combinazioni delle azioni agli stati limite ultimi statici (SLU)

Nella seguente Tabella 3 si riportano le combinazioni agli stati limite ultimi statici (SLU); i carichi sono amplificati con i coefficienti parziali A1.

COMBINAZIONI ULS

Node	Load	FX (kN)	FY (kN)	FZ (kN)	MX (kN*m)	MY (kN*m)	MZ (kN*m)
*****	*****	*****	*****	*****	*****	*****	*****
2905	ULS_20	1776.4	-724.4	-46629.1	6075.956	31846.0	-28.7
2905	ULS_09	-8788.1	-724.4	-46224.7	6075.956	-17326.2	9.4
2905	ULS_53	-5498	-599.0	-43437	3541.083	1342	-90
2905	ULS_02	-6734	-1028.6	-46985	9769.646	-2638	-180
2905	ULS_48	-2699	-730	-30024.4	6675.550	6046	-149
2905	ULS_02	-6734	-1029	-46984.9	9769.646	-2638	-180
2905	ULS_37	-278	-1029	-36519	9769.646	20521	-199
2905	ULS_06	-5998	-639	-44077	3425.021	-561	-90
2905	ULS_20	1776	-724	-46629	6075.956	31846.0	-29
2905	ULS_31	-8183	-724	-35375	6075.956	-21024.8	9
2905	ULS_17	1254	-764	-45985	7648.432	26274	155.3
2905	ULS_16	-278	-1029	-46873	9769.646	26771	-198.7

Tabella 3: Combinazioni statiche SLU-A1: azioni agenti a base spalla

APPALTATORE: Consorzio  Soci  	ITINERARIO NAPOLI – BARI RADDOPPIO TRATTA APICE – ORSARA I LOTTO FUNZIONALE APICE – HIRPINIA
PROGETTAZIONE: Mandataria  Mandanti  	
PROGETTO ESECUTIVO RELAZIONE DI CALCOLO FONDAZIONI SPALLA A	COMMESSA IF1N LOTTO 01 E ZZ CODIFICA RG DOCUMENTO MD0000 001 REV. B FOGLIO 13 di 109

6.1.3 Combinazioni delle azioni agli stati limite di esercizio (SLE)

Nella seguente Tabella 4 si riportano le combinazioni di carico caratteristiche impiegate per gli stati limite di esercizio (SLE).

COMB SLE CARATTERISTICHE

Node	Load	FX (kN)	FY (kN)	FZ (kN)	MX (kN*m)	MY (kN*m)	MZ (kN*m)
*****	*****	*****	*****	*****	*****	*****	*****
2905 CH_20		506.8	-489.5	-34334.8	4098.238	20077.7	-17.7
2905 CH_09		-6208.7	-489.5	-33714.8	4098.238	-11445.2	8.5
2905 CH_29		-3939	-403.1	-31792	2350.049	1430	-60
2905 CH_02		-4792	-699.3	-34239	6645.610	-1316	-122
2905 CH_24		-2560	-487	-30024.4	4450.366	6682	-99
2905 CH_15		-910	-699	-34503.1	6645.610	16577	-135
2905 CH_15		-910	-699	-34503	6645.610	16577	-135
2905 CH_06		-4284	-431	-32234	2270.007	117	-60
2905 CH_20		507	-490	-34335	4098.238	20077.7	-18
2905 CH_09		-6209	-490	-33715	4098.238	-11445.2	9
2905 CH_17		147	-517	-33890	5182.704	16235	109.2
2905 CH_16		-910	-699	-34503	6645.610	16578	-134.9

Tabella 4: Combinazioni di esercizio SLE: azioni agenti a base spalla

6.2 SCARICHI A INTRADOSSO PLINTO - GROUP

6.2.1 Combinazioni delle azioni agli stati limite ultimi sismici (SLV)

Nella Tabella 5 si riportano le combinazioni di carico agli stati limite ultimi (SLV) in presenza dell'azione sismica, ottenute:

- amplificando le azioni di taglio e i momenti a base pila del coefficiente $\gamma_{Rd} = 1.1$;
- sistema di riferimento codice calcolo Group (Figura 6-2).

APPALTATORE: Consorzio Soci 		ITINERARIO NAPOLI – BARI RADDOPPIO TRATTA APICE – ORSARA I LOTTO FUNZIONALE APICE – HIRPINIA					
PROGETTAZIONE: Mandataria Mandanti 							
PROGETTO ESECUTIVO RELAZIONE DI CALCOLO FONDAZIONI SPALLA A		COMMESSA IF1N	LOTTO 01 E ZZ	CODIFICA RG	DOCUMENTO MD0000 001	REV. B	FOGLIO 14 di 109



Figura 6-2: Convenzioni di segno Group

NODE	LOAD	VERT	LONG	LONG	TRASV	TRASV	TORC
		FX	FY	MZ	FZ	MY	MX
2905	ULS_V_02	28788.4	13666.5	-57363.1	89.6	872.3	1.2
2905	ULS_V_05	28735.6	-23603.3	61110.3	89.6	872.3	29.1
2905	ULS_V_09	28735.6	-3307.4	-4364.4	-16472.8	-58490.0	-8647.4
2905	ULS_V_14	28735.6	-3307.4	-4364.7	16652.0	60234.6	8674.8
2905	ULS_V_30	23761.4	-3307.4	-1503.4	5058.3	18675.6	2612.0
2905	ULS_V_19	38026.1	2723.4	-29900.3	89.6	882.3	12.0
2905	ULS_V_15	32999.1	-3307.4	-6816.9	16652.0	60239.2	8674.8
2905	ULS_V_10	28735.6	-3307.4	-4364.7	-16472.8	-58490.0	-8647.4
2905	ULS_V_04	33051.9	13666.5	-59815.6	89.6	876.9	1.2
2905	ULS_V_05	28735.6	-23603.3	61110.3	89.6	872.3	29.1
2905	ULS_V_09	28735.6	-3307.4	-4364.4	-16472.8	-58490.0	-8647.4
2905	ULS_V_16	32999.1	-3307.4	-6817.2	16652.0	60239.2	8674.8

Tabella 5: Combinazioni sismiche SLV: azioni agenti ad intradosso plinto - Group

6.2.2 Combinazioni delle azioni agli stati limite ultimi statici (SLU)

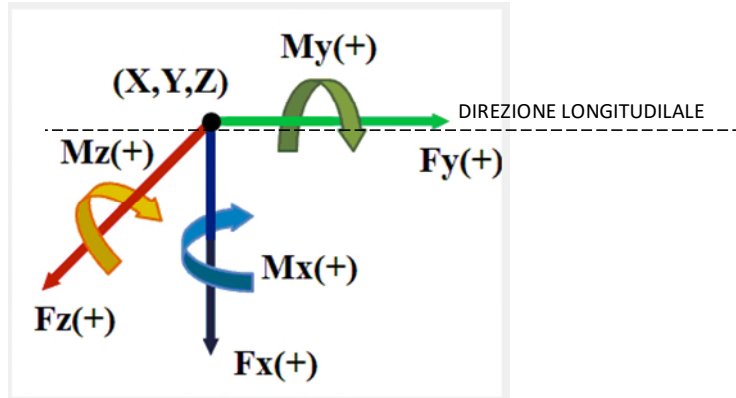
Nella Tabella 6 si riportano gli scarichi per gli stati limite ultimi statici (SLU), ottenuti considerando sistema di riferimento codice calcolo Group (Figura 6-2).

NODE	LOAD	VERT	LONG	LONG	TRASV	TRASV	TORC
		FX	FY	MZ	FZ	MY	MX
2905	ULS_20	46629.1	1776.4	-31846.0	724.4	6075.956	28.7
2905	ULS_09	46224.7	-8788.1	17326.2	724.4	6075.956	-9.4
2905	ULS_53	43436.6	-5497.6	-1342.3	599.0	3541.083	89.8
2905	ULS_02	46984.9	-6734.1	2638.4	1028.6	9769.646	179.6
2905	ULS_48	30024.4	-2698.6	-6046.3	730.1	6675.550	149.0
2905	ULS_02	46984.9	-6734.1	2638.4	1028.6	9769.646	179.6

APPALTATORE: Consorzio  Soci  	ITINERARIO NAPOLI – BARI RADDOPPIO TRATTA APICE – ORSARA I LOTTO FUNZIONALE APICE – HIRPINIA
PROGETTAZIONE: Mandataria  Mandanti  	
PROGETTO ESECUTIVO RELAZIONE DI CALCOLO FONDAZIONI SPALLA A	COMMESSA IF1N LOTTO 01 E ZZ CODIFICA RG DOCUMENTO MD0000 001 REV. B FOGLIO 15 di 109

2905	ULS_37	36518.5	-277.6	-20521.4	1028.6	9769.646	198.7
2905	ULS_06	44077.4	-5997.5	561.0	639.3	3425.021	89.9
2905	ULS_20	46629.1	1776.4	-31846.0	724.4	6075.956	28.7
2905	ULS_31	35375.5	-8183.3	21024.8	724.4	6075.956	-9.4
2905	ULS_17	45984.7	1254.3	-26273.9	764.3	7648.432	-155.3
2905	ULS_16	46873.1	-277.6	-26771.0	1028.6	9769.646	198.7

Tabella 6: Combinazioni di statiche SLU-A1: azioni agenti ad intradosso plinto - Group

6.2.3 Combinazioni delle azioni agli stati limite di esercizio (SLE)

Nella **Tabella 7** si riportano le combinazioni di carico caratteristiche impiegate per gli stati limite di esercizio ottenute considerando sistema di riferimento codice calcolo Group (Figura 6-2).

NODE	LOAD	VERT	LONG	LONG	TRASV	TRASV	TORC
		FX	FY	MZ	FZ	MY	MX
2905	CH_20	34334.8	506.8	-20077.7	489.5	4098.238	17.7
2905	CH_09	33714.8	-6208.7	11445.2	489.5	4098.238	-8.5
2905	CH_29	31792.0	-3939.4	-1429.5	403.1	2350.049	59.9
2905	CH_02	34239.1	-4792.2	1315.5	699.3	6645.610	121.8
2905	CH_24	30024.4	-2560.3	-6682.3	486.7	4450.366	99.3
2905	CH_15	34503.1	-909.7	-16577.2	699.3	6645.610	134.9
2905	CH_15	34503.1	-909.7	-16577.2	699.3	6645.610	134.9
2905	CH_06	32233.9	-4284.2	-117.1	430.8	2270.007	59.9
2905	CH_20	34334.8	506.8	-20077.7	489.5	4098.238	17.7
2905	CH_09	33714.8	-6208.7	11445.2	489.5	4098.238	-8.5
2905	CH_17	33890.4	146.7	-16234.7	517.0	5182.704	-109.2
2905	CH_16	34503.1	-909.7	-16577.7	699.3	6645.610	134.9

Tabella 7: Combinazioni di esercizio SLE: azioni agenti ad intradosso plinto - Group

APPALTATORE: Consorzio Soci   	ITINERARIO NAPOLI – BARI RADDOPPIO TRATTA APICE – ORSARA I LOTTO FUNZIONALE APICE – HIRPINIA																	
PROGETTAZIONE: Mandataria Mandanti   	<table border="1" style="width: 100%; border-collapse: collapse;"> <tr> <td style="width: 16.6%;">COMMESSA</td> <td style="width: 16.6%;">LOTTO</td> <td style="width: 16.6%;">CODIFICA</td> <td style="width: 16.6%;">DOCUMENTO</td> <td style="width: 16.6%;">REV.</td> <td style="width: 16.6%;">FOGLIO</td> </tr> <tr> <td>IF1N</td> <td>01 E ZZ</td> <td>RG</td> <td>MD0000 001</td> <td>B</td> <td>16 di 109</td> </tr> </table>						COMMESSA	LOTTO	CODIFICA	DOCUMENTO	REV.	FOGLIO	IF1N	01 E ZZ	RG	MD0000 001	B	16 di 109
COMMESSA	LOTTO	CODIFICA	DOCUMENTO	REV.	FOGLIO													
IF1N	01 E ZZ	RG	MD0000 001	B	16 di 109													
PROGETTO ESECUTIVO RELAZIONE DI CALCOLO FONDAZIONI SPALLA A																		

7 ANALISI DELL'INTERAZIONE FONDAZIONE-TERRENO

L'analisi di interazione terreno-fondazione è stata sviluppata con il software GROUP della Ensoft.

Il programma considera che il comportamento di un palo soggetto ad azioni orizzontali all'interno di un gruppo differisce da quello di un palo singolo ed isolato. In un gruppo di pali caricato da azioni orizzontali i fenomeni di interazione reciproca palo – terreno – palo determinano, complessivamente, una diminuzione della rigidità del sistema.

La diversità di comportamento si manifesta mediante un differente valore dello sforzo di taglio agente in testa a ciascun palo, differenti valori di momento flettente, diversa ubicazione del valore massimo di momento al variare della profondità (nell'ipotesi in cui il vincolo in testa al palo non sia un incastro). La modalità di risposta di ciascun palo è funzione essenzialmente dalla posizione geometrica che questo occupa all'interno del gruppo. Precisamente, la risposta del singolo palo all'interno del gruppo è condizionata:

- dalla fila di appartenenza all'interno del gruppo (effetto ombra o shadowing);
- dalla posizione all'interno della singola fila (effetto di bordo).

7.1 DESCRIZIONE DEL MODELLO DI CALCOLO GROUP

Il modello di calcolo è stato costruito nel seguente modo:

APPALTATORE: Consorzio Soci   	ITINERARIO NAPOLI – BARI RADDOPPIO TRATTA APICE – ORSARA I LOTTO FUNZIONALE APICE – HIRPINIA																	
PROGETTAZIONE: Mandataria Mandanti   	<table border="1" style="width: 100%; border-collapse: collapse;"> <tr> <td style="width: 16.6%;">COMMESSA</td> <td style="width: 16.6%;">LOTTO</td> <td style="width: 16.6%;">CODIFICA</td> <td style="width: 16.6%;">DOCUMENTO</td> <td style="width: 16.6%;">REV.</td> <td style="width: 16.6%;">FOGLIO</td> </tr> <tr> <td>IF1N</td> <td>01 E ZZ</td> <td>RG</td> <td>MD0000 001</td> <td>B</td> <td>17 di 109</td> </tr> </table>						COMMESSA	LOTTO	CODIFICA	DOCUMENTO	REV.	FOGLIO	IF1N	01 E ZZ	RG	MD0000 001	B	17 di 109
COMMESSA	LOTTO	CODIFICA	DOCUMENTO	REV.	FOGLIO													
IF1N	01 E ZZ	RG	MD0000 001	B	17 di 109													
PROGETTO ESECUTIVO RELAZIONE DI CALCOLO FONDAZIONI SPALLA A																		



Figura 7-1: Vista frontale del modello GROUPv2016

APPALTATORE: Consorzio Soci   	ITINERARIO NAPOLI – BARI RADDOPPIO TRATTA APICE – ORSARA I LOTTO FUNZIONALE APICE – HIRPINIA
PROGETTAZIONE: Mandataria Mandanti   	
PROGETTO ESECUTIVO RELAZIONE DI CALCOLO FONDAZIONI SPALLA A	COMMESSA LOTTO CODIFICA DOCUMENTO REV. FOGLIO IF1N 01 E ZZ RG MD0000 001 B 18 di 109

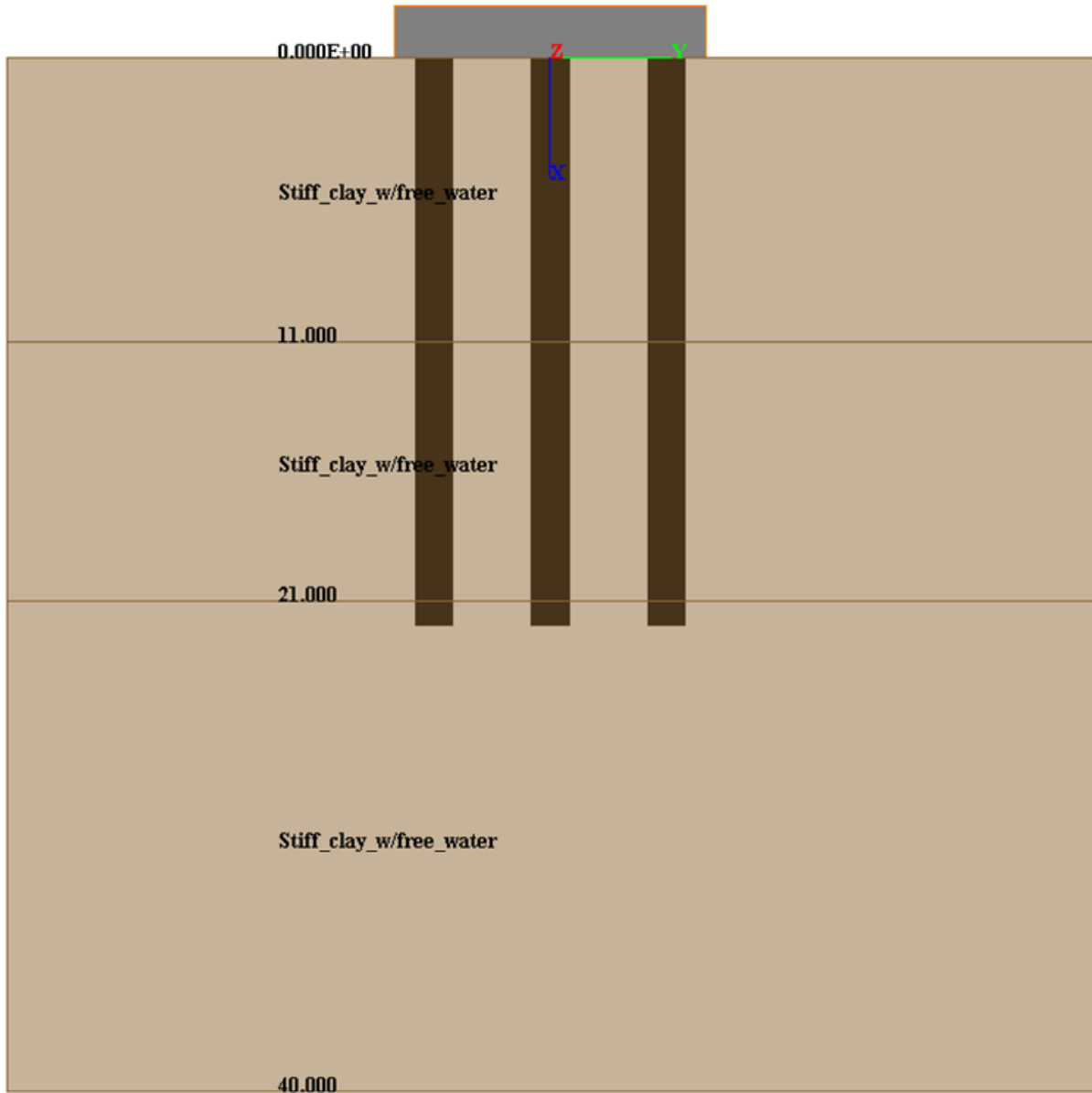

Figura 7-2: Vista in pianta del modello GROUPv2016

In accordo al § 4.2 nelle seguenti Figura 7-3 ÷ Figura 7-6 si riporta il modello stratigrafico di calcolo e i parametri geotecnici assegnati ai singoli strati. I parametri di rigidità del terreno sono stati assunti in accordo ai criteri illustrati nella relazione al ref. 2), § 8.1.1 per le “stiff clays with free water”.

Layer	Soil Type	Depth for Top of Soil Layer (m)	Depth for Bottom of Soil Layer (m)	Properties of Layer
1	Stiff Clay with Free Water (Reese)	0	11	1: Stiff Clay with Free Water
2	Stiff Clay with Free Water (Reese)	11	21	2: Stiff Clay with Free Water
3	Stiff Clay with Free Water (Reese)	21	40	3: Stiff Clay with Free Water

Figura 7-3: Modello stratigrafico GROUP V2016

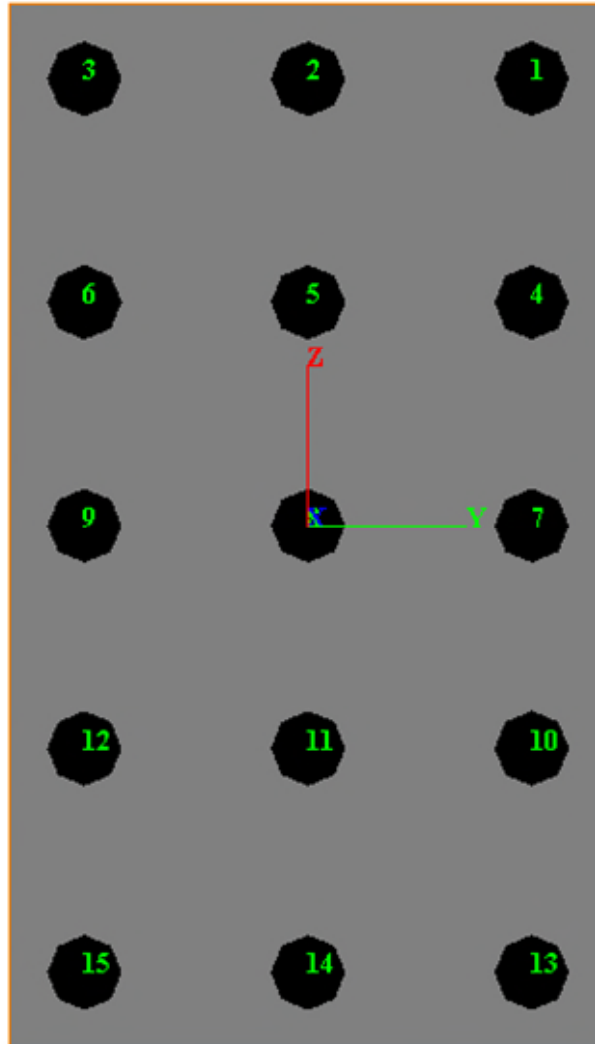
APPALTATORE: Consorzio Soci   	ITINERARIO NAPOLI – BARI RADDOPPIO TRATTA APICE – ORSARA I LOTTO FUNZIONALE APICE – HIRPINIA
PROGETTAZIONE: Mandataria Mandanti   	
PROGETTO ESECUTIVO RELAZIONE DI CALCOLO FONDAZIONI SPALLA A	COMMESSA LOTTO CODIFICA DOCUMENTO REV. FOGLIO IF1N 01 E ZZ RG MD0000 001 B 19 di 109

1=Top, 2=Bottom	Effective Unit Weight (kN/m ³)	Undrained Cohesion, c (kN/m ²)	p-y Modulus, k (kN/m ³)	Strain Factor E50	Ultimate Unit Side Friction (kN/m ²)	Ultimate Unit Tip Resistance (kN/m ²)
1	10	80	135000	0.007	20	0
2	10	80	135000	0.007	20	0

A linear interpolation with depth will be used to compute values between the top and bottom of the layer. (k=55000 per analisi SLE)

p-y Modulus, k, and Strain Factor E50:
 - Always check recommended value in Geotechnical Investigation Reports.
 - Program will help to estimate values for p-y Modulus, k, and Strain Factor E50 if zero input values are entered.

Ultimate Unit Side Friction and Ultimate Unit Tip Resistance:
 - The program uses Ultimate Unit Side Friction to generate t-z curves.
 - The program uses Ultimate Unit Tip Resistance to generate q-w curves.
 - Always check recommended values in Geotechnical Investigation Reports.
 - Program will help to estimate values for Ultimate Unit Side Friction and Ultimate Unit Tip Resistance if zero input values are entered.

Figura 7-4: Layer no.1 (depositi franosi)

1=Top, 2=Bottom	Effective Unit Weight (kN/m ³)	Undrained Cohesion, c (kN/m ²)	p-y Modulus, k (kN/m ³)	Strain Factor E50	Ultimate Unit Side Friction (kN/m ²)	Ultimate Unit Tip Resistance (kN/m ²)
1	12	250	540000	0.004	118.6	3354.1
2	12	250	540000	0.004	118.6	3354.1

A linear interpolation with depth will be used to compute values between the top and bottom of the layer. (k=220000 per analisi SLE)

p-y Modulus, k, and Strain Factor E50:
 - Always check recommended value in Geotechnical Investigation Reports.
 - Program will help to estimate values for p-y Modulus, k, and Strain Factor E50 if zero input values are entered.

Ultimate Unit Side Friction and Ultimate Unit Tip Resistance:
 - The program uses Ultimate Unit Side Friction to generate t-z curves.
 - The program uses Ultimate Unit Tip Resistance to generate q-w curves.
 - Always check recommended values in Geotechnical Investigation Reports.
 - Program will help to estimate values for Ultimate Unit Side Friction and Ultimate Unit Tip Resistance if zero input values are entered.

Figura 7-5: Layer no.2 (FYR alt)

APPALTATORE: Consorzio Soci 	ITINERARIO NAPOLI – BARI RADDOPPIO TRATTA APICE – ORSARA I LOTTO FUNZIONALE APICE – HIRPINIA
PROGETTAZIONE: Mandataria Mandanti 	
PROGETTO ESECUTIVO RELAZIONE DI CALCOLO FONDAZIONI SPALLA A	COMMESSA LOTTO CODIFICA DOCUMENTO REV. FOGLIO IF1N 01 E ZZ RG MD0000 001 B 20 di 109

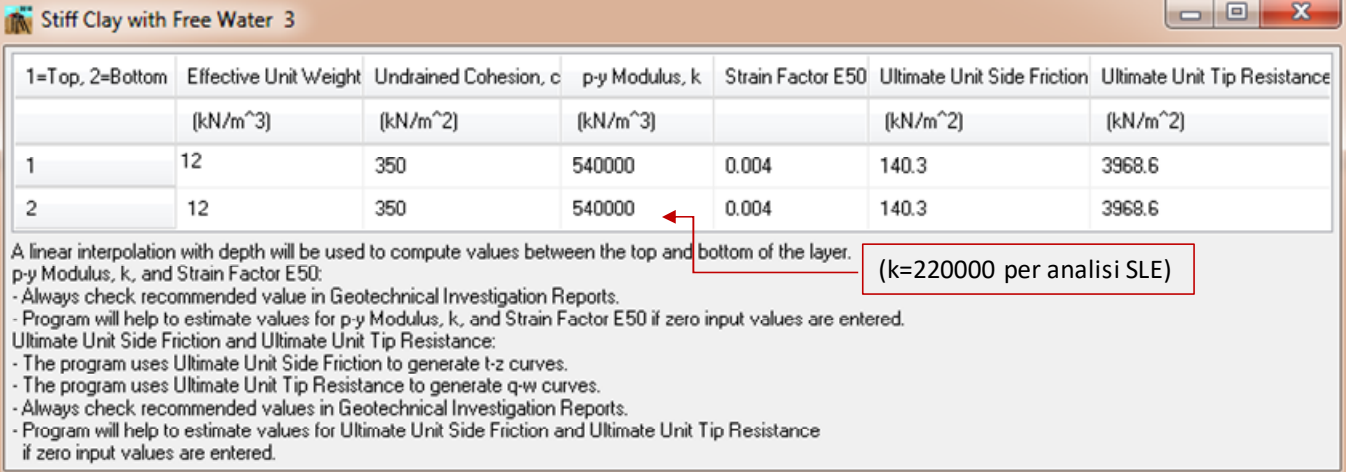

1=Top, 2=Bottom	Effective Unit Weight (kN/m ³)	Undrained Cohesion, c (kN/m ²)	p-y Modulus, k (kN/m ³)	Strain Factor E50	Ultimate Unit Side Friction (kN/m ²)	Ultimate Unit Tip Resistance (kN/m ²)
1	12	350	540000	0.004	140.3	3968.6
2	12	350	540000	0.004	140.3	3968.6

A linear interpolation with depth will be used to compute values between the top and bottom of the layer.
 p-y Modulus, k, and Strain Factor E50:
 - Always check recommended value in Geotechnical Investigation Reports.
 - Program will help to estimate values for p-y Modulus, k, and Strain Factor E50 if zero input values are entered.
 Ultimate Unit Side Friction and Ultimate Unit Tip Resistance:
 - The program uses Ultimate Unit Side Friction to generate t-z curves.
 - The program uses Ultimate Unit Tip Resistance to generate q-w curves.
 - Always check recommended values in Geotechnical Investigation Reports.
 - Program will help to estimate values for Ultimate Unit Side Friction and Ultimate Unit Tip Resistance if zero input values are entered.

Figura 7-6: Layer no.3 (FYR)

7.2 SINTESI DEI RISULTATI AGLI STATI LIMITE DI ESERCIZIO (SLE)

Si riassumono nel seguito le sollecitazioni massime di sforzo assiale, taglio e momento, agenti in testa ai pali.

Si ricorda che per le analisi allo SLE (vedasi Ref. 2)) sono stati utilizzati per le curve p-y i coefficienti di rigidezza del terreno suggeriti dal programma per carichi ciclici; facendo riferimento alle Figura 7-4, Figura 7-5 e Figura 7-6 sono stati utilizzati i valori evidenziati di lato.

SLE	FOR. X, KN	FOR.H, KN	MOM, KN-M	MOM X, KN- M
	*****	*****	*****	*****
max	2921.7	516.1	1206.0	0.3
min	1573.6	30.1	73.8	-0.2

Tabella 8: Sollecitazioni allo SLE massime e minime per i pali di fondazione

Nelle seguenti figure sono diagrammati l'andamento con la profondità del momento flettente e del taglio relativi alle combinazioni in cui tali sollecitazioni risultano massime.

APPALTATORE: Consorzio Soci 		ITINERARIO NAPOLI – BARI RADDOPPIO TRATTA APICE – ORSARA I LOTTO FUNZIONALE APICE – HIRPINIA					
PROGETTAZIONE: Mandataria Mandanti 							
PROGETTO ESECUTIVO RELAZIONE DI CALCOLO FONDAZIONI SPALLA A		COMMESSA IF1N	LOTTO 01 E ZZ	CODIFICA RG	DOCUMENTO MD0000 001	REV. B	FOGLIO 21 di 109



Figura 7-7: Combinazioni SLE: Andamento con la profondità del momento (combo SLE 4-1651-CH_01).

APPALTATORE: Consorzio Soci 		ITINERARIO NAPOLI – BARI RADDOPPIO TRATTA APICE – ORSARA I LOTTO FUNZIONALE APICE – HIRPINIA					
PROGETTAZIONE: Mandataria Mandanti 							
PROGETTO ESECUTIVO RELAZIONE DI CALCOLO FONDAZIONI SPALLA A		COMMESSA IF1N	LOTTO 01 E ZZ	CODIFICA RG	DOCUMENTO MD0000 001	REV. B	FOGLIO 22 di 109

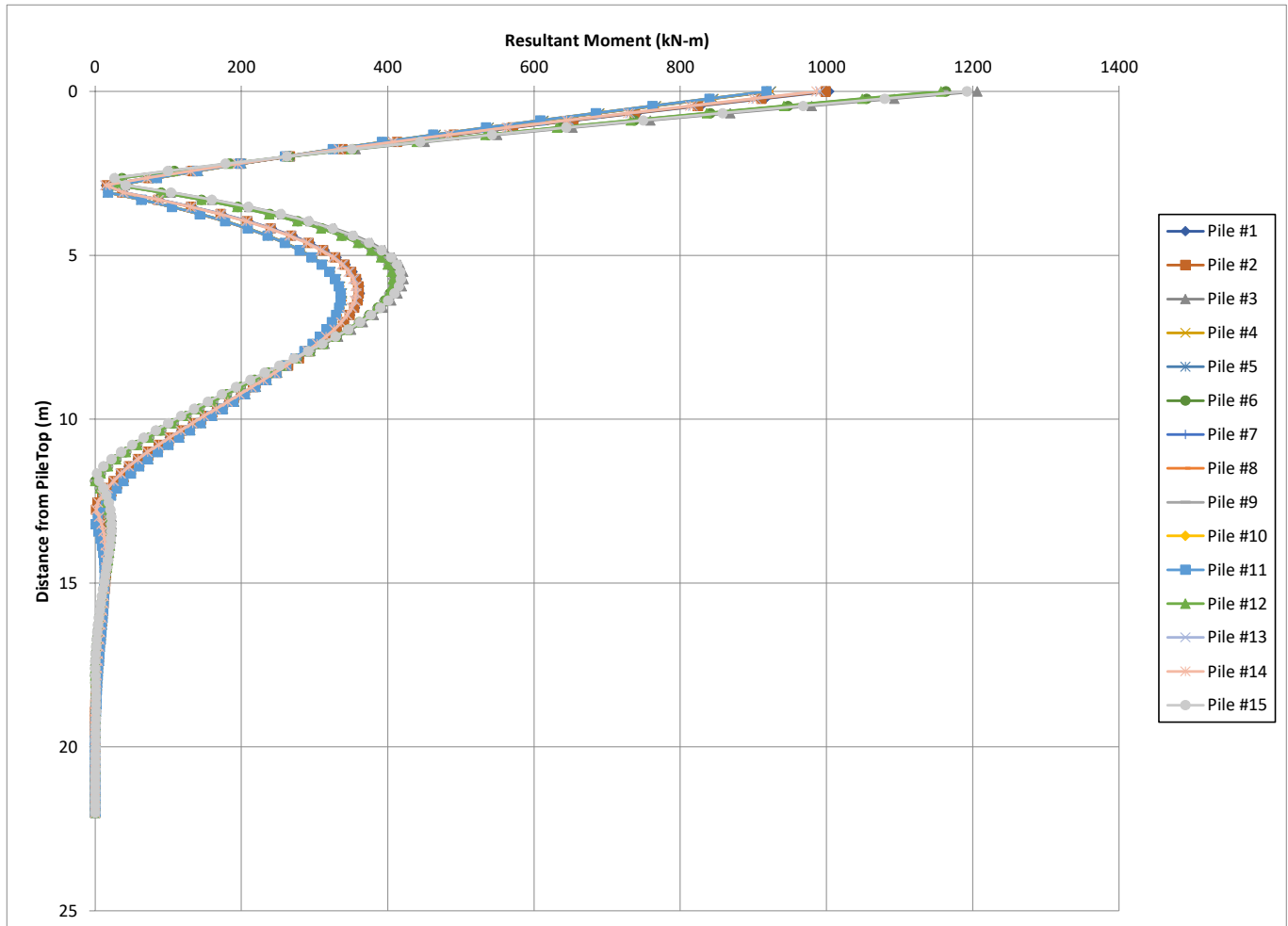

Figura 7-8: Combinazioni SLE: Andamento con la profondità del taglio (combo SLE 1-1651-CH_20).

7.2.1 Spostamenti

Nella Tabella 9 si riportano gli spostamenti e le rotazioni ad intradosso plinto e sommità spalla.

Gli spostamenti orizzontali (direzione y-2) e direzione z-3) tengono già conto dell'interazione fra pali e sono quindi rappresentativi degli spostamenti orizzontali del gruppo di pali; lo spostamento verticale non tiene conto dell'effetto gruppo.

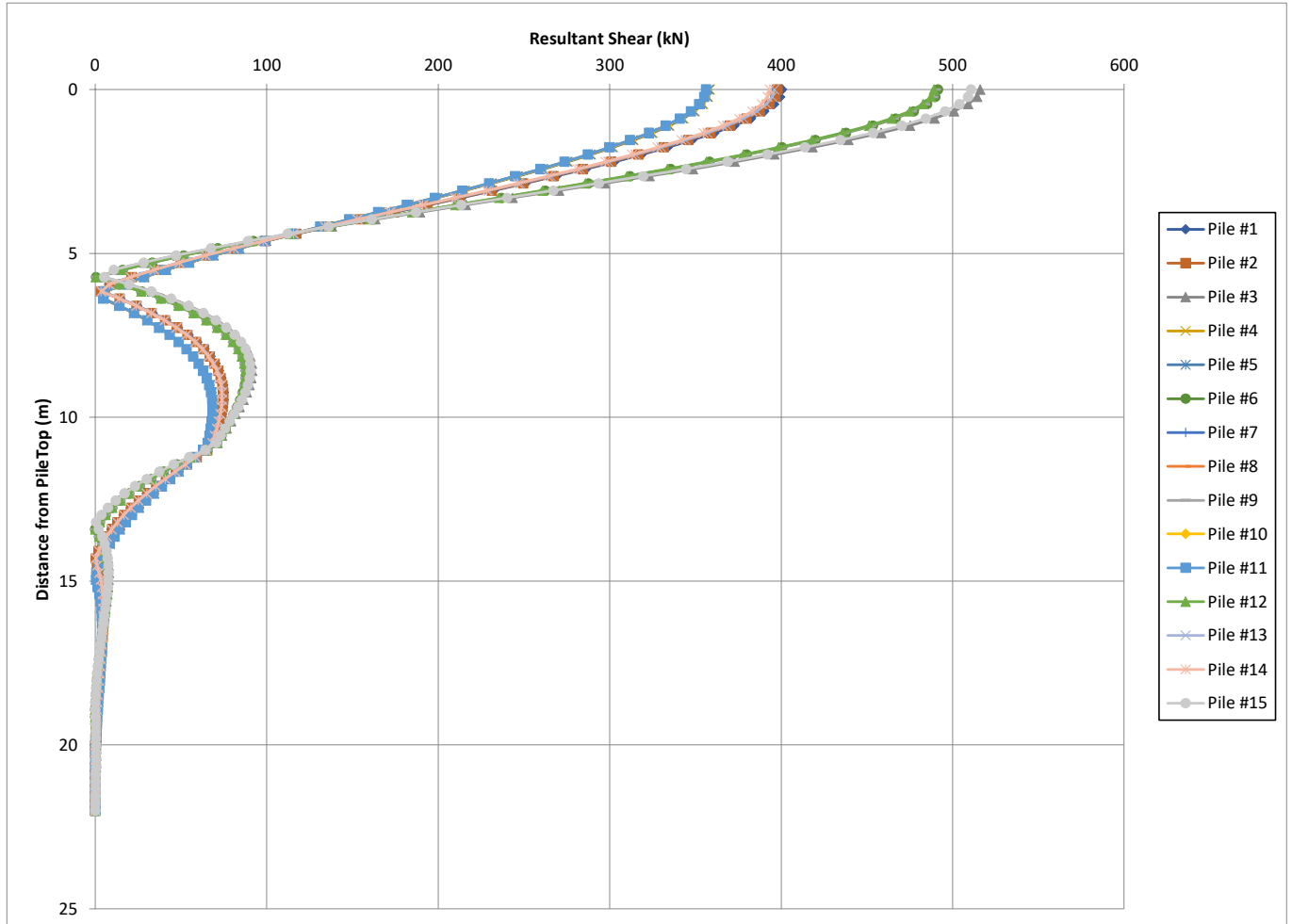
Il coefficiente amplificativo del cedimento verticale per effetto gruppo E_G viene valutato in accordo a Mandolini et al. (2005) ed è riportato in Tabella 10.

APPALTATORE: Consorzio Soci 	ITINERARIO NAPOLI – BARI RADDOPPIO TRATTA APICE – ORSARA I LOTTO FUNZIONALE APICE – HIRPINIA
PROGETTAZIONE: Mandataria Mandanti 	
PROGETTO ESECUTIVO RELAZIONE DI CALCOLO FONDAZIONI SPALLA A	
COMMESSA IF1N LOTTO 01 E ZZ CODIFICA RG DOCUMENTO MD0000 001 REV. B FOGLIO 23 di 109	

VERTICAL , M	HORIZONTAL Y, M	HORIZONTAL Z, M	ANGLE ROT. X,RAD	ANGLE ROT. Y,RAD	ANGLE ROT. Z,RAD	Ppostamento testa pila - sle		
						H pila (m)	4,85	
						asse Y (mm)	asse Z (mm)	asse X (mm)
0,00134506	0,000266283	0,000115143	-3,60053E-07	5,20877E-06	-5,90858E-05	0,553	0,140	2,745
0,00132049	-0,00151047	0,000116726	7,87913E-07	5,21638E-06	7,86101E-05	-1,892	0,142	2,695
0,00124429	-0,000880128	9,22036E-05	7,58558E-07	3,3082E-06	2,57742E-05	-1,005	0,108	2,540
0,00134127	-0,00109383	0,00016673	1,31342E-06	8,19851E-06	3,97648E-05	-1,287	0,206	2,738
0,00117424	-0,000528699	0,000115556	8,70996E-07	5,53844E-06	9,18824E-07	-0,533	0,142	2,397
0,00135173	-8,39724E-05	0,000169225	-3,79541E-07	8,21043E-06	-3,87286E-05	0,104	0,209	2,759
0,00135173	-8,39724E-05	0,000169225	-3,79541E-07	8,21043E-06	-3,87286E-05	0,104	0,209	2,759
0,0012618	-0,000968007	9,79155E-05	7,99383E-07	3,30447E-06	3,19867E-05	-1,123	0,114	2,575
0,00134506	0,000266283	0,000115143	-3,60053E-07	5,20877E-06	-5,90858E-05	0,553	0,140	2,745
0,00132049	-0,00151047	0,000116726	7,87913E-07	5,21638E-06	7,86101E-05	-1,892	0,142	2,695
0,00132745	0,000155978	0,000124378	-6,58666E-07	6,3218E-06	-4,57958E-05	0,378	0,155	2,709
0,00135173	-0,000083969	0,000169225	-3,79569E-07	8,21043E-06	-3,87298E-05	0,104	0,209	2,759

Tabella 9: Combinazioni SLE: spostamenti e rotazioni ad intradosso plinto.

DATI FONDAZIONE		
Larghezza plinto	12	m
Profondità plinto	21	m
Diametro palo	1,5	m
Lunghezza palo	22	m
interasse palo	4,5	m
numero pali	15	-
Coefficiente R	1,75	-
Coefficiente RG	0,14	-
Coeff. amplificazione cedimento del gruppo EG	2,04	-

Tabella 10: Coefficiente amplificativo del cedimento verticale per effetto gruppo.

7.3 SINTESI DEI RISULTATI AGLI STATI LIMITE ULTIMI STATICI (SLU)

Si riassumono nel seguito le sollecitazioni massime di sforzo assiale, taglio e momento, agenti in testa ai pali.

SLU	FOR. X, KN	FOR.H, KN	MOM, KN-M	MOM X, KN-M
	*****	*****	*****	*****
max	4065.4	734.7	1743.6	0.6
min	1328.9	61.2	94.1	-0.2

Tabella 11: Sollecitazioni allo SLU massime e minime per i pali di fondazione

Nelle seguenti figure sono diagrammati l'andamento con la profondità del momento flettente e del taglio relativi alle combinazioni in cui tali sollecitazioni risultano massime.

APPALTATORE: Consorzio Soci 		ITINERARIO NAPOLI – BARI RADDOPPIO TRATTA APICE – ORSARA I LOTTO FUNZIONALE APICE – HIRPINIA											
PROGETTAZIONE: Mandataria Mandanti 		COMMESSA IF1N		LOTTO 01 E ZZ		CODIFICA RG		DOCUMENTO MD0000 001		REV. B		FOGLIO 24 di 109	
PROGETTO ESECUTIVO RELAZIONE DI CALCOLO FONDAZIONI SPALLA A													



Figura 7-9: Combinazioni statica SLU: Andamento con la profondità del momento (combo 2-2905 CH_09).

APPALTATORE: Consorzio Soci 			ITINERARIO NAPOLI – BARI RADDOPPIO TRATTA APICE – ORSARA I LOTTO FUNZIONALE APICE – HIRPINIA											
PROGETTAZIONE: Mandataria Mandanti 			COMMESSA IF1N		LOTTO 01 E ZZ		CODIFICA RG		DOCUMENTO MD0000 001		REV. B		FOGLIO 25 di 109	
PROGETTO ESECUTIVO RELAZIONE DI CALCOLO FONDAZIONI SPALLA A														

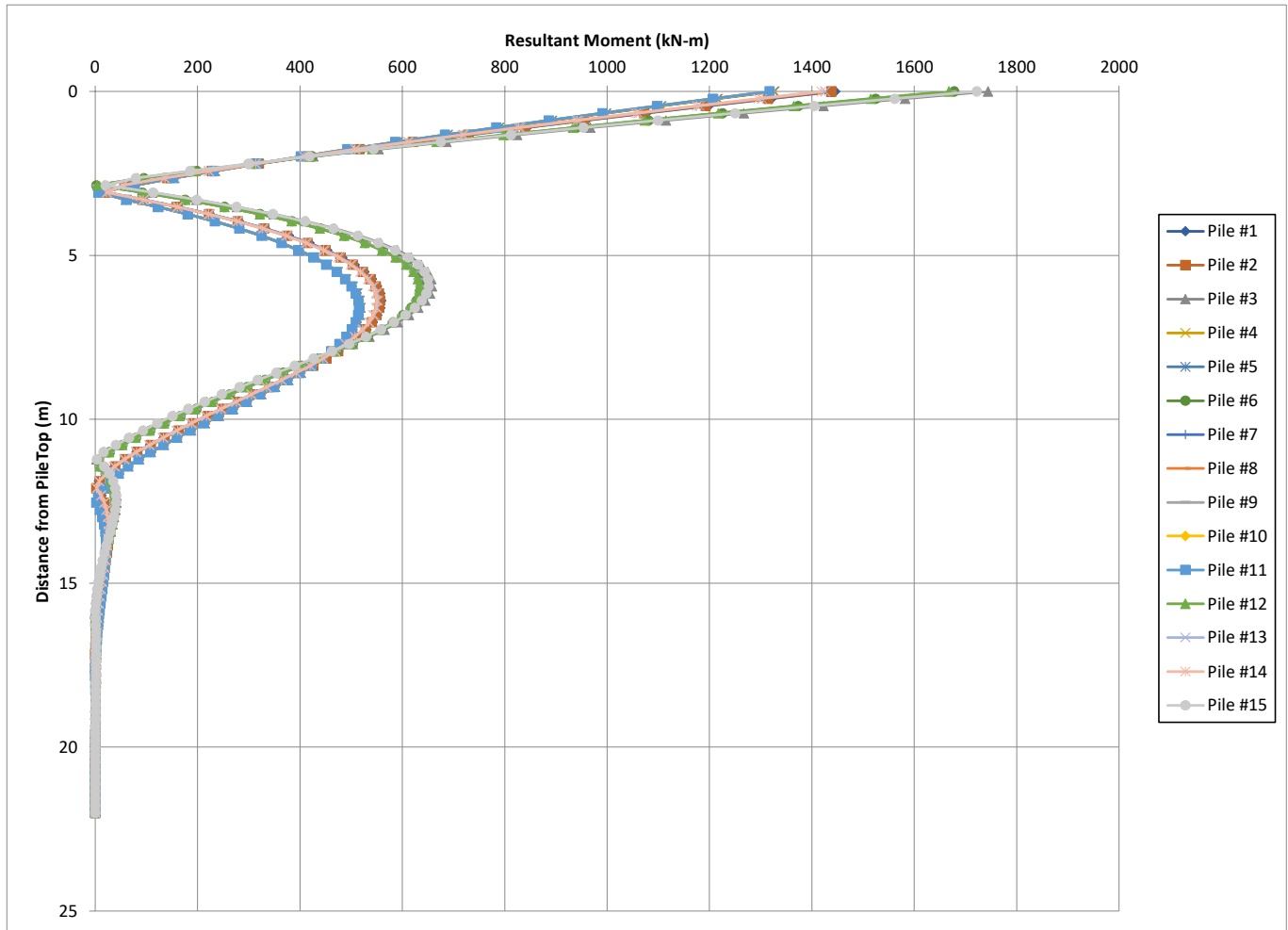

Figura 7-10: Combinazioni statica SLU: Andamento con la profondità del taglio (combo 2-2905 CH_09).

7.4 SINTESI DEI RISULTATI AGLI STATI LIMITE ULTIMI SISMICI (SLV)

Si riassumono nel seguito le sollecitazioni massime di sforzo assiale, taglio e momento, agenti in testa ai pali.

SLV	FOR. X, KN	FOR.H, KN	MOM, KN-M	MOM X, KN- M
max	4829.7	1968.1	5711.1	11.0
min	-1140.0	153.9	225.6	-10.9

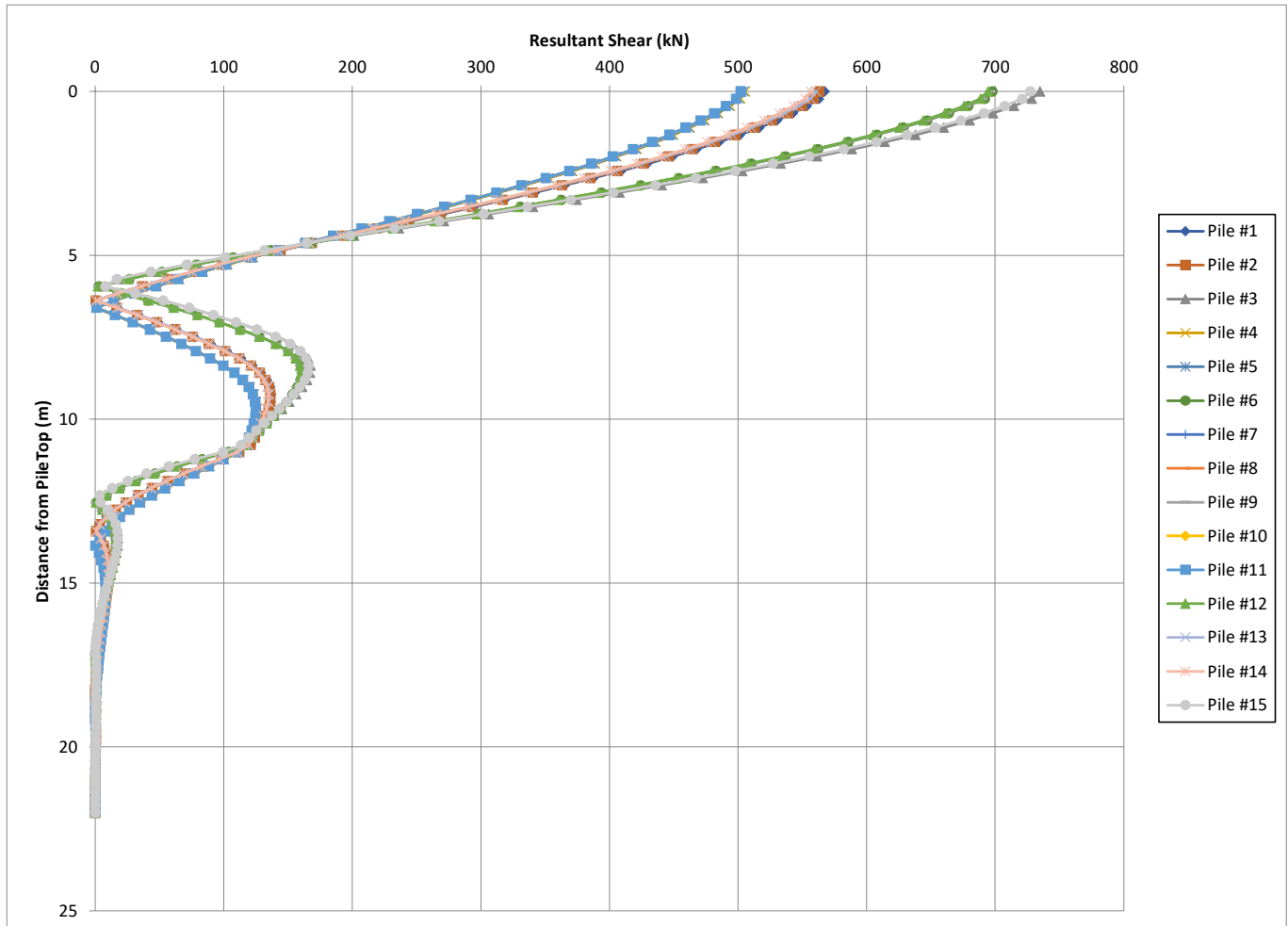
Tabella 12: Sollecitazioni allo SLV massime e minime per i pali di fondazione

Nelle seguenti figure sono diagrammati l'andamento con la profondità del momento flettente e del taglio relativi alle combinazioni in cui tali sollecitazioni risultano massime.

APPALTATORE: Consorzio Soci 		ITINERARIO NAPOLI – BARI RADDOPPIO TRATTA APICE – ORSARA I LOTTO FUNZIONALE APICE – HIRPINIA					
PROGETTAZIONE: Mandataria Mandanti 							
PROGETTO ESECUTIVO RELAZIONE DI CALCOLO FONDAZIONI SPALLA A		COMMESSA IF1N	LOTTO 01 E ZZ	CODIFICA RG	DOCUMENTO MD0000 001	REV. B	FOGLIO 26 di 109



Figura 7-11: Combinazioni sismica SLV: Andamento con la profondità del momento (combo 14-2905 ULS_V_05).

APPALTATORE: Consorzio Soci 		ITINERARIO NAPOLI – BARI RADDOPPIO TRATTA APICE – ORSARA I LOTTO FUNZIONALE APICE – HIRPINIA					
PROGETTAZIONE: Mandataria Mandanti 							
PROGETTO ESECUTIVO RELAZIONE DI CALCOLO FONDAZIONI SPALLA A		COMMESSA IF1N	LOTTO 01 E ZZ	CODIFICA RG	DOCUMENTO MD0000 001	REV. B	FOGLIO 27 di 109

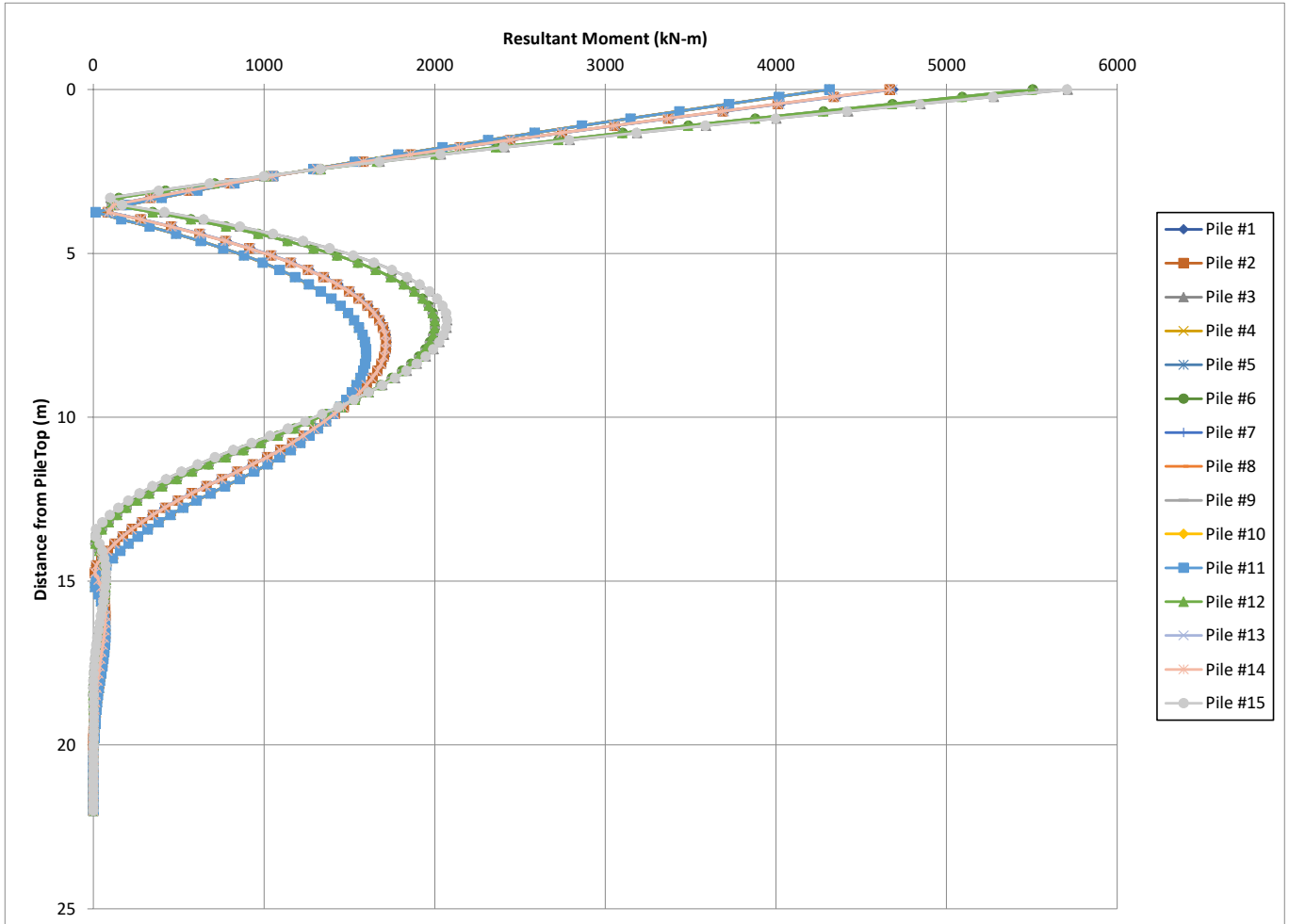

Figura 7-12: Combinazioni sismica SLV: Andamento con la profondità del taglio (combo 14-2905 ULS_V_05).

APPALTATORE: Consorzio Soci   	ITINERARIO NAPOLI – BARI RADDOPPIO TRATTA APICE – ORSARA I LOTTO FUNZIONALE APICE – HIRPINIA					
PROGETTAZIONE: Mandataria Mandanti   						
PROGETTO ESECUTIVO RELAZIONE DI CALCOLO FONDAZIONI SPALLA A	COMMESSA IF1N	LOTTO 01 E ZZ	CODIFICA RG	DOCUMENTO MD0000 001	REV. B	FOGLIO 28 di 109

8 VERIFICA DEI PALI DI FONDAZIONE

Nel seguito di riportano le verifiche strutturali dei pali di fondazione.

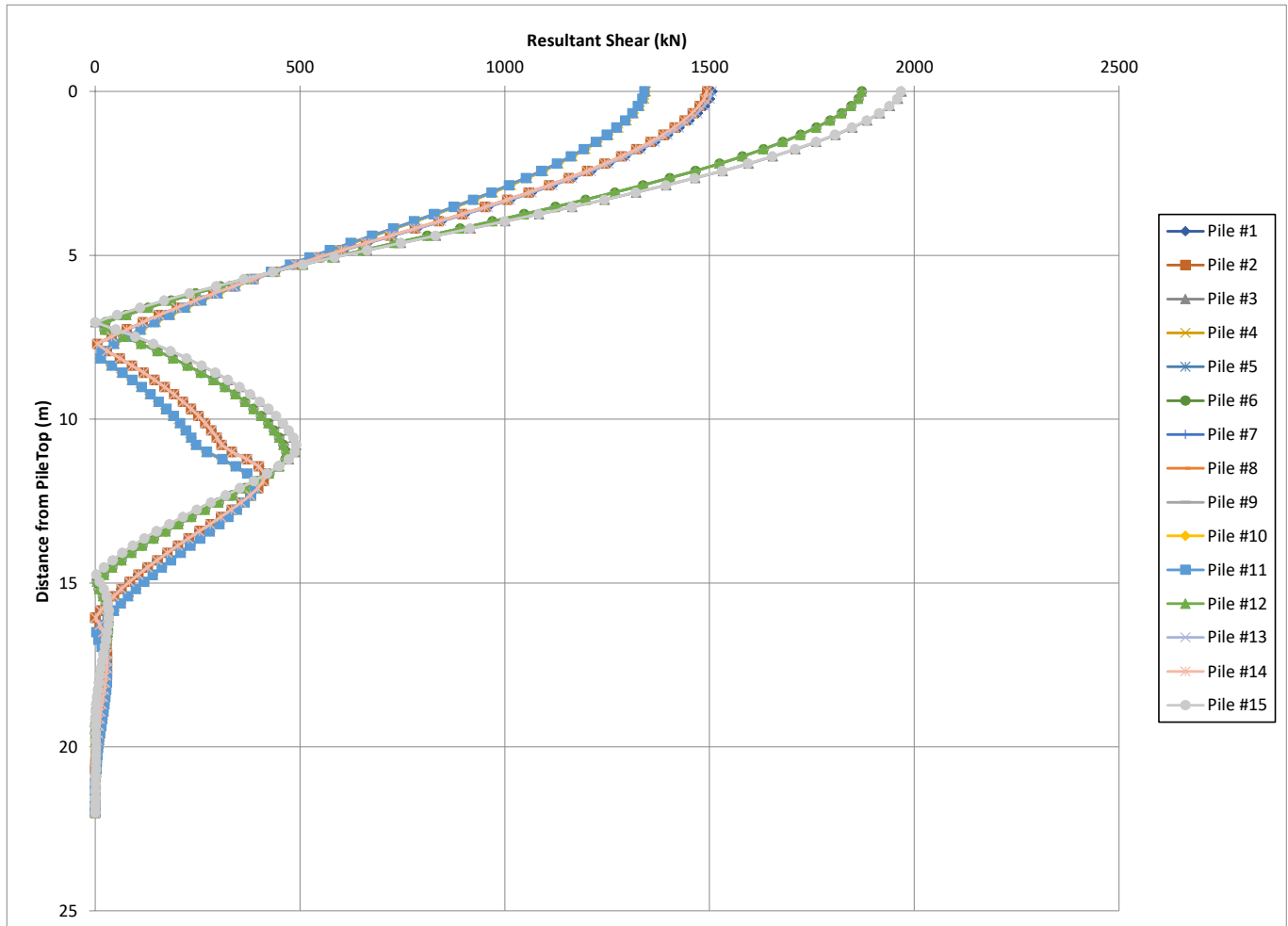
Le sollecitazioni massime agenti lungo il fusto del palo sono riassunte nella Tabella 13.

LOAD CASE :	PILE GROUP	FOR. X, KN	FOR. Y, KN	FOR. Z, KN	MOM X, KN- M	MOM Y, KN- M	MOM Z, KN- M	FOR.H, KN	MOM, KN-M
*****	*****	*****	*****	*****	*****	*****	*****		
SLV-14	3	4829.7	-1968.1	6.8562	0.1753	-20.109	-5711.1	1968.1	5711.1
SLV-14	13	-1140	-1505.9	6.2901	0.1753	-20.119	-4682.3	1505.9	4682.3

LOAD CASE :	PILE GROUP	FOR. X, KN	FOR. Y, KN	FOR. Z, KN	MOM X, KN- M	MOM Y, KN- M	MOM Z, KN- M	FOR.H, KN	MOM, KN-M
*****	*****	*****	*****	*****	*****	*****	*****		
2_SLE	3					-92.412	-1202.5		1206.0
2_SLE	13	1573.6							

Tabella 13: Sollecitazioni massime agenti nel palo

Nel seguito si riportano le verifiche strutturali del palo trivellato di diametro $\varnothing = 1500\text{mm}$ in cls – C25/30 e lunghezza L22m. Per le verifiche si considerano le sollecitazioni risultanti. Sono risultate più severe le verifiche in presenza di trazione.

In riferimento all'andamento dei momenti lungo il fusto del palo- Momenti Figura 7-11 e Taglio Figura 7-12 - sono state previste n. 3 ordini di armature principali:

1. L'armatura massima:
 - o ferri correnti: corona esterna n.26 $\varnothing 30$;
 - o ferri correnti: corona interna n.13 $\varnothing 30$;
 - o staffatura: doppia spirale $\varnothing 12$ passo 10.
2. L'armatura media:
 - o ferri correnti: corona esterna n.26 $\varnothing 30$;
 - o staffatura: spirale $\varnothing 12$ passo 10.
3. L'armatura minima:
 - o ferri correnti: corona esterna n.26 $\varnothing 26$;
 - o staffatura: spirale $\varnothing 12$ passo 20.

La verifica strutturale del palo è soddisfatta; di seguito la scheda di calcolo.

APPALTATORE: Consorzio HirpiniaAV Soci salini impregilo ASTALDI	ITINERARIO NAPOLI – BARI RADDOPPIO TRATTA APICE – ORSARA I LOTTO FUNZIONALE APICE – HIRPINIA
PROGETTAZIONE: Mandataria ROKSOJL Mandanti NETENGINEERING Alpina	
PROGETTO ESECUTIVO RELAZIONE DI CALCOLO FONDAZIONI SPALLA A	
COMMESSA IF1N LOTTO 01 E ZZ CODIFICA RG DOCUMENTO MD0000 001 REV. B FOGLIO 29 di 109	

geometria				
sezione trasversale				
D	c	d	passo	interferro
[cm]	[cm]	[cm]	[cm]	[cm]
150	6.0	141.3	16.0	13.0
armatura longitudinale				
nbarre	ϕ	r_i	A_{sl}	C_i
	[mm]	[cm]	[cm ²]	[cm]
26	30	66.30	183.78	8.70
13	30	59.30	91.89	15.70
armatura a taglio				
Tipo	ϕ	p	A_{sw}	
	[mm]	[cm]	[cm ²]	
spirale	12	5	2.26	

sollecitazioni e risultati	
SLE	SLU
M_{Ek} 1206.0 [kNm]	M_{Ed} 4682.3 [kNm]
N_{Ek} -1573.6 [kN]	N_{Ed} 1140.0 [kN]
momento di cracking	V_{Ed} 1968 [kN]
M_{cr} 1360.5 [kNm]	presso-flessione
quota asse neutro	M_{Rd} 5230.1 [kNm]
y_n 77.14 [cm]	FS 1.12
tensioni e fessure	taglio
$\sigma_{c,min}$ -3.9 [MPa]	V_{Rdc} 527.7 [kN]
$\sigma_{s,min}$ -51.9 [MPa]	predisporre armatura a taglio
$\sigma_{s,max}$ 48.6 [MPa]	
k_2 0.5	V_{Rds} 2835.4 [kN]
$\epsilon_{sm}-\epsilon_{cm}$ - [%]	V_{Rdmax} 4487.1 [kN]
$S_{r,max}$ - [cm]	θ 30.0 [°]
w_k - [mm]	sezione duttile
	al 93.2 [cm]

materiali			
calcestruzzo		acciaio	
R_{ck}	30 [MPa]	f_{yk}	450 [MPa]
f_{ck}	24.9 [MPa]	γ_s	1.15
γ_c	1.5	f_{yd}	391.3 [MPa]
α_{cc}	0.85	E_s	200000 [MPa]
f_{cd}	14.1 [MPa]	ϵ_{uk}	10 [%]
ν	0.5		
ϵ_{c2}	2.0 [%]		
ϵ_{cu2}	3.5 [%]		
α_e	15.0		
k_t	0.6		
k_1	0.8		
k_3	3.4		
k_4	0.425		
valori limite			
	0,55 f_{ck}		13.7 [MPa]
	0,75 f_{yk}		337.5 [MPa]
	$w_{k,lim}$		0.2 [mm]



Tabella 8-14: Verifica del palo D=1500mm; trazione e armatura massima

APPALTATORE: Consorzio HirpiniaAV Soci salini impregilo ASTALDI	ITINERARIO NAPOLI – BARI RADDOPPIO TRATTA APICE – ORSARA I LOTTO FUNZIONALE APICE – HIRPINIA
PROGETTAZIONE: Mandataria ROKSOJL Mandanti NETENGINEERING Alpina	
PROGETTO ESECUTIVO RELAZIONE DI CALCOLO FONDAZIONI SPALLA A	
COMMESSA IF1N LOTTO 01 E ZZ CODIFICA RG DOCUMENTO MD0000 001 REV. B FOGLIO 30 di 109	

geometria				
sezione trasversale				
D	c	d	passo	interferro
[cm]	[cm]	[cm]	[cm]	[cm]
150	6,0	141,3	16,0	13,0
armatura longitudinale				
n _{barre}	φ	r _i	A _{sl}	c _i
	[mm]	[cm]	[cm ²]	[cm]
26	30	66,30	183,78	8,70
armatura a taglio				
Tipo	φ	ρ	A _{sw}	
	[mm]	[cm]	[cm ²]	
spirale	12	10	2,26	

sollecitazioni e risultati	
SLE	SLU
M _{Ek} 1206,0 [kNm]	M _{Ed} 2074,5 [kNm]
N _{Ek} -1573,6 [kN]	N _{Ed} 1140,0 [kN]
momento di cracking	V _{Ed} 585 [kN]
M _{cr} 1196,1 [kNm]	presso-flessione
quota asse neutro	M _{Rd} 3509,7 [kNm]
y _n 69,68 [cm]	FS 1,69
tensioni e fessure	taglio
σ _{c,min} -4,9 [MPa]	V _{Rdc} 440,6 [kN]
σ _{s,min} -64,4 [MPa]	predisporre armatura a taglio
σ _{s,max} 75,7 [MPa]	
	V _{Rds} 1417,4 [kN]
k ₂ 0,5	V _{Rdmax} 4487,1 [kN]
ε _{sm-ε_{cm}} 0,21 [%]	θ 30,0 [°]
S _{r,max} 43,5 [cm]	sezione duttile
w _k 0,09186 [mm]	a _i 92,2 [cm]

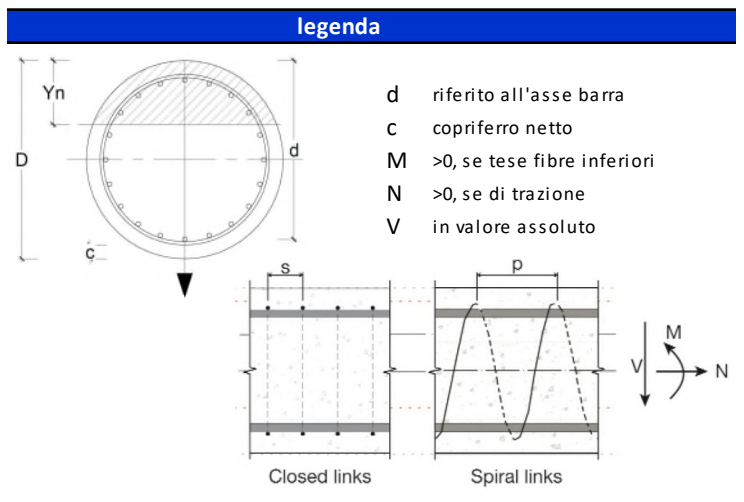
materiali			
calcestruzzo		acciaio	
R _{ck}	30 [MPa]	f _{yk}	450 [MPa]
f _{ck}	24,9 [MPa]	γ _s	1,15
γ _c	1,5	f _{yd}	391,3 [MPa]
α _{cc}	0,85	E _s	200000 [MPa]
f _{cd}	14,1 [MPa]	ε _{uk}	10 [‰]
v	0,5		
ε _{c2}	2,0 [‰]		
ε _{cu2}	3,5 [‰]		
α _e	15,0		
k _t	0,6		
k ₁	0,8		
k ₃	3,4		
k ₄	0,425		
		valori limite	
		0,55 f _{ck}	13,7 [MPa]
		0,75 f _{yk}	337,5 [MPa]
		w _{k,lim}	0,2 [mm]



Tabella 8-15: Verifica del palo D=1500mm; armatura media

APPALTATORE: Consorzio HirpiniaAV Soci salini impregilo ASTALDI		ITINERARIO NAPOLI – BARI RADDOPPIO TRATTA APICE – ORSARA I LOTTO FUNZIONALE APICE – HIRPINIA					
PROGETTAZIONE: Mandataria ROKSOJL Mandanti NETENGINEERING Alpina							
PROGETTO ESECUTIVO RELAZIONE DI CALCOLO FONDAZIONI SPALLA A		COMMESSA IF1N	LOTTO 01 E ZZ	CODIFICA RG	DOCUMENTO MD0000 001	REV. B	FOGLIO 31 di 109

geometria				
sezione trasversale				
D	c	d	passo	interferro
[cm]	[cm]	[cm]	[cm]	[cm]
150	6,0	141,5	16,1	13,5
armatura longitudinale				
n _{barre}	φ	r _i	A _{sl}	c _i
	[mm]	[cm]	[cm ²]	[cm]
26	26	66,50	138,04	8,50
armatura a taglio				
Tipo	φ	p	A _{sw}	
	[mm]	[cm]	[cm ²]	
spirale	12	20	2,26	

sollecitazioni e risultati	
SLE	SLU
M _{Ek} 1206,0 [kNm]	M _{Ed} 600,0 [kNm]
N _{Ek} -1573,6 [kN]	N _{Ed} 1140,0 [kN]
momento di cracking	
M _{cr} 1149,3 [kNm]	
quota asse neutro	
y _n 65,99 [cm]	
tensioni e fessure	
σ _{c,min} -5,5 [MPa]	
σ _{s,min} -71,2 [MPa]	
σ _{s,max} 93,7 [MPa]	
prezzo-flessione	
M _{Rd} 2542,3 [kNm]	
FS 4,24	
taglio	
V _{Rdc} 385,8 [kN]	
predisporre armatura a taglio	
V _{Rds} 709,1 [kN]	
V _{Rdmax} 4493,4 [kN]	
θ 30,0 [°]	
sezione duttile	
a _i 90,4 [cm]	

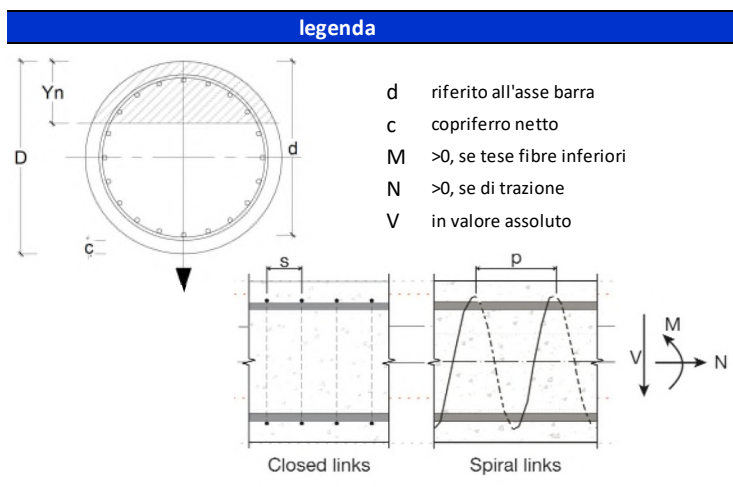
materiali			
calcestruzzo		acciaio	
R _{ck}	30 [MPa]	f _{yk}	450 [MPa]
f _{ck}	24,9 [MPa]	γ _s	1,15
γ _c	1,5	f _{yd}	391,3 [MPa]
α _{cc}	0,85	E _s	200000 [MPa]
f _{cd}	14,1 [MPa]	ε _{uk}	10 [‰]
v	0,5		
ε _{c2}	2,0 [‰]		
ε _{cu2}	3,5 [‰]		
α _e	15,0		
k _t	0,6		
k ₁	0,8		
k ₃	3,4		
k ₄	0,425		
		valori limite	
		0,55 f _{ck}	13,7 [MPa]
		0,75 f _{yk}	337,5 [MPa]
		w _{k,lim}	0,2 [mm]



Tabella 8-16: Verifica del palo D=1500mm; armatura minima

APPALTATORE: Consorzio HirpiniaAV Soci salini impregilo ASTALDI	ITINERARIO NAPOLI – BARI RADDOPPIO TRATTA APICE – ORSARA I LOTTO FUNZIONALE APICE – HIRPINIA					
PROGETTAZIONE: Mandataria SOJL Mandanti NETENGINEERING Alpina						
PROGETTO ESECUTIVO RELAZIONE DI CALCOLO FONDAZIONI SPALLA A	COMMESSA IF1N	LOTTO 01 E ZZ	CODIFICA RG	DOCUMENTO MD0000 001	REV. B	FOGLIO 32 di 109

8.1.1 Schemi armatura e incidenza del palo

Nelle Figura 8-1 e Figura 8-2 sono schematizzate le armature correnti e le armature di taglio. Nella Tabella 8-17 l'incidenza di armatura valutata con una percentuale di incremento pari al 10% dovuta a ganci di sollevamento, armature di confezionamento, legatura, ecc.; si considera una incidenza di progetto pari a 200kg/m³.

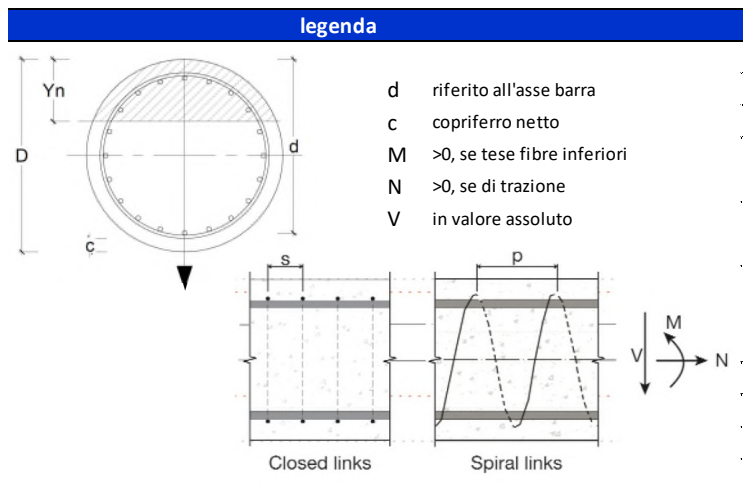
Tabella ferri						
ARMATURA PALO LUNGH. = 22 m – SPALLA A						
POS.	N.	DIAM.	LUNG. (cm)	P.U.	LUNG. TOT. (cm)	PESO (kg)
1	26	30	940	5,549	24440	1356
2	13	30	940	5,549	12220	678
3	26	30	900	5,549	23400	1298
4	26	26	900	4,168	23400	975
5	1	12	48137	0,888	48137	427
6	1	12	38690	0,888	38690	343
7	1	12	15058	0,888	15058	134
8	22	40	450	9,864	9900	977

Kg 6189

AREA PALO (m²) **1,77**

LUNGH. PALO (m) **22,00**

VOLUME (m³) **38,86**

INCIDENZA DI CALCOLO (kg/m³) **159,3**

Incremento percentuale % (*) **10**

INCIDENZA DI PROGETTO (kg/m³) **~200**

(*) incremento in % dovuto a ganci di sollevamento, armature di confezionamento, legature, ecc.

Tabella 8-17 Incidenza armatura

APPALTATORE: Consorzio HirpiniaAV Soci salini impregilo ASTALDI		ITINERARIO NAPOLI – BARI					
PROGETTAZIONE: Mandataria ROKSOJL Mandanti NETENGINEERING Alpina		RADDOPPIO TRATTA APICE – ORSARA I LOTTO FUNZIONALE APICE – HIRPINIA					
PROGETTO ESECUTIVO RELAZIONE DI CALCOLO FONDAZIONI SPALLA A		COMMESSA IF1N	LOTTO 01 E ZZ	CODIFICA RG	DOCUMENTO MD0000 001	REV. B	FOGLIO 33 di 109



Figura 8-1: VI01 SP A Schema armatura gabbie

APPALTATORE: Consorzio HirpiniaAV Soci salini impregio ASTALDI		ITINERARIO NAPOLI – BARI					
PROGETTAZIONE: Mandataria ROKSOJL Mandanti NETENGINEERING Alpina		RADDOPPIO TRATTA APICE – ORSARA I LOTTO FUNZIONALE APICE – HIRPINIA					
PROGETTO ESECUTIVO RELAZIONE DI CALCOLO FONDAZIONI SPALLA A		COMMESSA IF1N	LOTTO 01 E ZZ	CODIFICA RG	DOCUMENTO MD0000 001	REV. B	FOGLIO 34 di 109

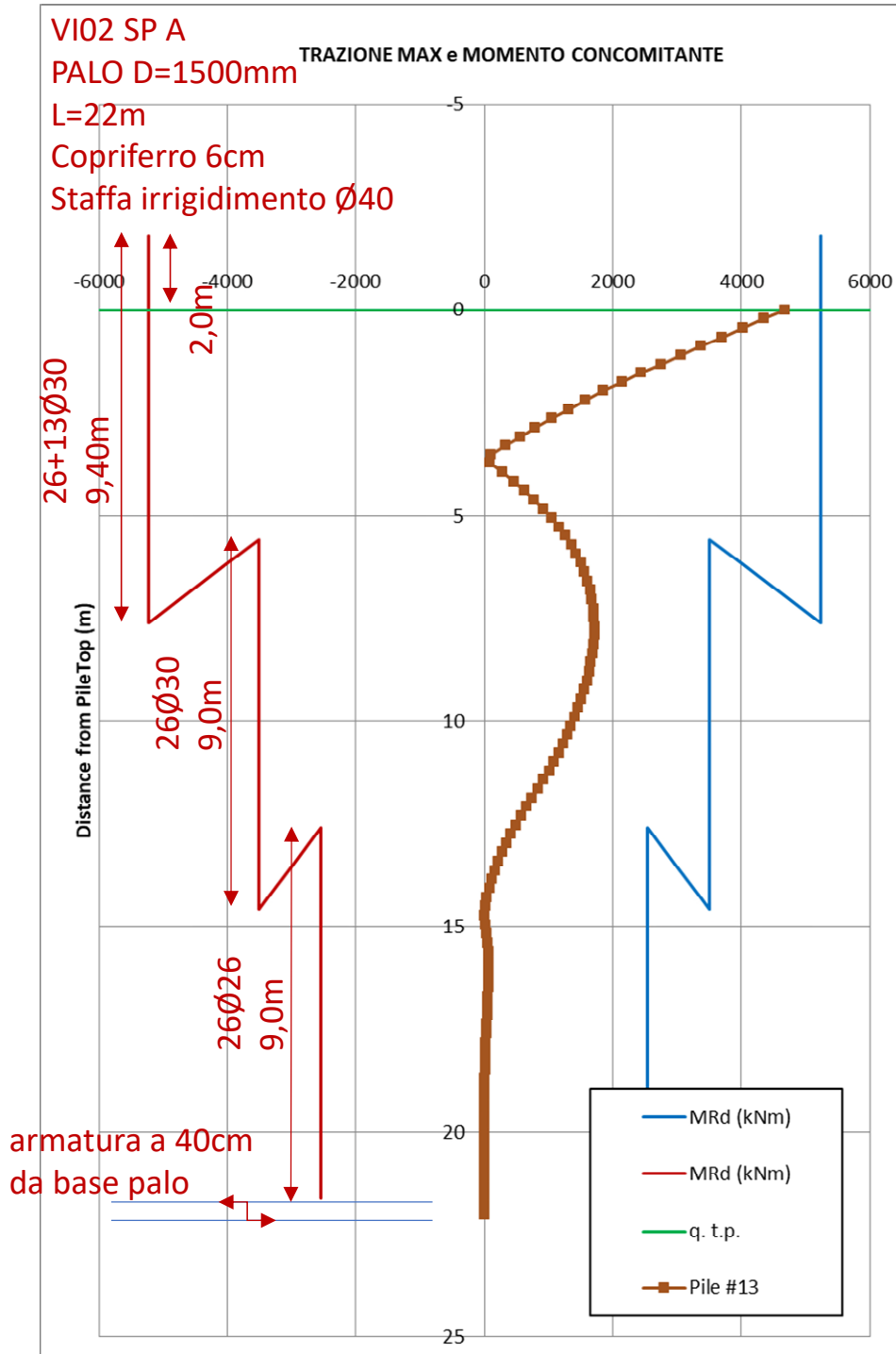

Figura 8-2: VI01 SP A Schema armatura a taglio

APPALTATORE: Consorzio Soci   	ITINERARIO NAPOLI – BARI RADDOPPIO TRATTA APICE – ORSARA I LOTTO FUNZIONALE APICE – HIRPINIA					
PROGETTAZIONE: Mandataria Mandanti   						
PROGETTO ESECUTIVO RELAZIONE DI CALCOLO FONDAZIONI SPALLA A	COMMESSA IF1N	LOTTO 01 E ZZ	CODIFICA RG	DOCUMENTO MD0000 001	REV. B	FOGLIO 35 di 109

9 VERIFICHE ALLO SLU DI TIPO GEOTECNICO

9.1 VERIFICA DI CAPACITÀ PORTANTE DEL PALO SINGOLO

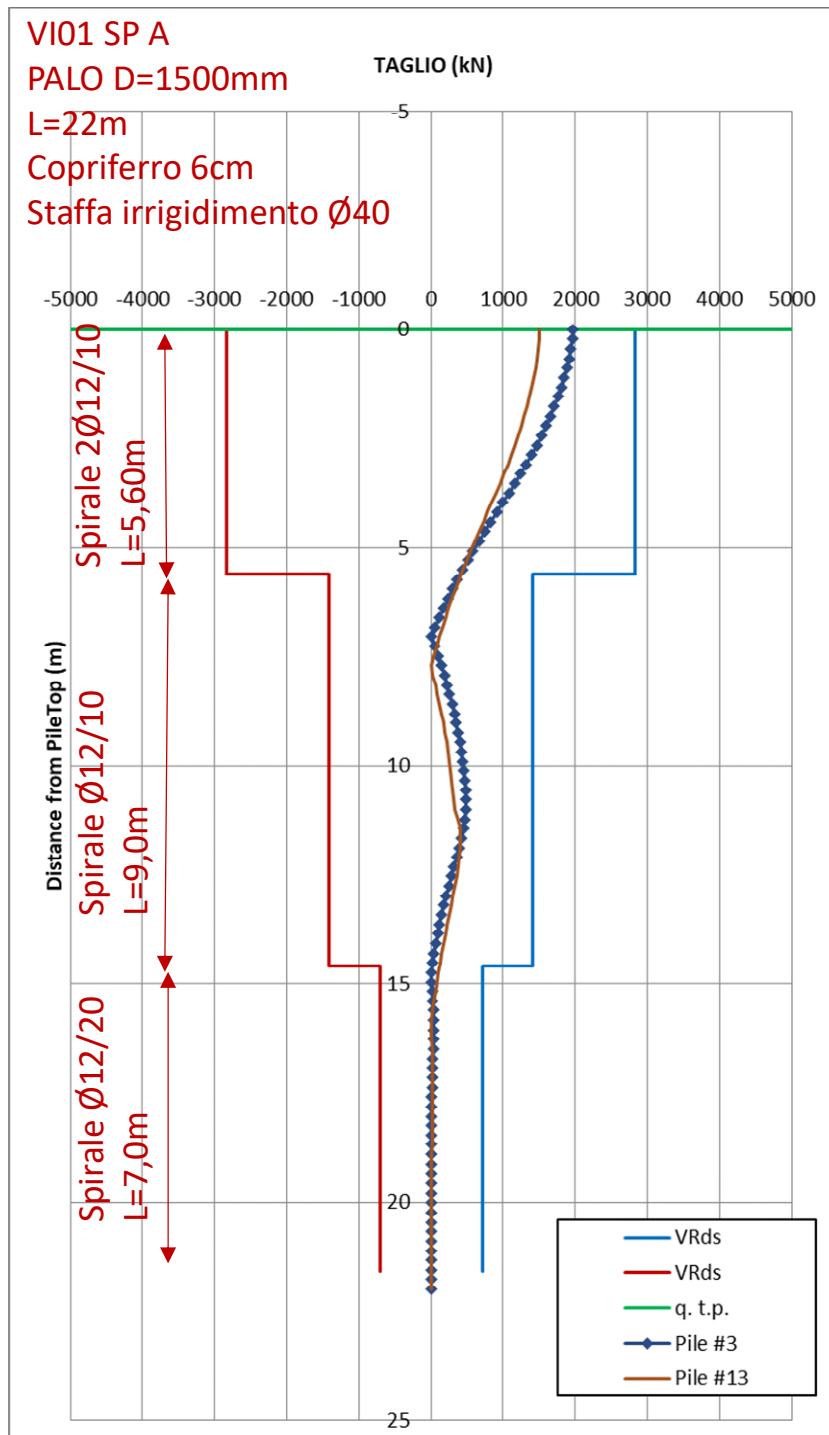
La verifica di capacità portante verticale per il singolo palo è stata condotta in accordo ai criteri esposti nel documento di cui al ref. 2).

Di seguito si riporta, per i pali di fondazione di lunghezza $L = 22$ m, la capacità portante a compressione ($R_{c,d}$) e a trazione ($R_{t,d}$), secondo l'approccio 2 (A1+M1+R3).

I carichi assiali massimi agenti sui pali sono riassunti nella seguente tabella:

Massima compressione, N_{dc} , max [kN]	4829.7 (SLV)
Massima trazione, N_{dt} , max [kN]	-1140.0 (SLV)

Tabella 18: Combinazione SLU e SLV: Sollecitazioni massime di compressione e trazione

Si verifica inoltre che lo sforzo assiale massimo in esercizio (Tabella 19) sia inferiore della resistenza laterale di calcolo ($R_{c,s,k}$) divisa per un fattore pari a 1.25.

Massima compressione, N_{dcSLE} , max [kN]	2921.7 (SLE)
--	--------------

Tabella 19: Combinazione SLE: Sollecitazione massima di compressione

In Tabella 20 si riporta, per i pali di lunghezza 22.0 m, la capacità portante a compressione ($R_{c,d}$) e a trazione ($R_{t,d}$) del palo isolato secondo l'Approccio 2 (A1+M1+R3).

Combinazione SLU A1+M1+R3 (metodo AGI)							Comb. SLU A1+M1+R3 (metodo AGI)				
L palo	Q l-c,k	Q b-c,k	Q l-c,d	Q b-c,d	ΔW palo	Q _{c,d}	L palo	Q l-t,k	Q l-t,d	ΔW palo	Q _{t,d}
m	kN	kN	kN	kN	kN	kN	m	kN	kN	kN	kN
22	8737,6	6198,7	4748,7	2869,8	758,1	6860,3	22	8737,6	4368,8	583,2	4951,9

Tabella 20: Capacità portante a compressione e a trazione dei pali di fondazione secondo l'Approccio 2 (A1+M1+R3).

9.1.1 Capacità portante verticale del palo singolo

Stratigrafia e parametri geotecnici

Dati di input		
Diametro Palo	1.5	m
Sovraccarico efficace	25.0	kPa
HW da testa palo	0.0	m
γ acqua	10.0	kN/m ³
Δz palo da p.c. originario	2.5	m
N° diametri per qb	4.0	(-)
L palo fuori terra	0.0	(m)

APPALTATORE: Consorzio Soci   	ITINERARIO NAPOLI – BARI RADDOPPIO TRATTA APICE – ORSARA I LOTTO FUNZIONALE APICE – HIRPINIA
PROGETTAZIONE: Mandataria Mandanti   	
PROGETTO ESECUTIVO RELAZIONE DI CALCOLO FONDAZIONI SPALLA A	COMMESSA IF1N LOTTO 01 E ZZ CODIFICA RG DOCUMENTO MD0000 001 REV. B FOGLIO 36 di 109

Peso calcestruzzo	25.0	kN/m³
Pressione max sul cls.	11.34	MPa

Caratteristiche del terreno													
Profondità (m)		Strato	Terreno	γ_{tot}	Nspt		c_u (kPa)		$\Delta-z$	ϕ°		Nq	
da	a	No.	(S,SL,G,A)	kN/m ³	da	a	da	a	(m)	da	a	da	a
0.0	11.0	1	A	20.0			120	120	1.00				
11.0	21.0	2	A	22.0			250	250	1.00				
21.0	40.0	3	A	22.0			350	350	1.00				

Verticali di indagine	ξ_3	ξ_4
3	1.60	1.48

Scelta di ξ	ξ
3	1.6

APPALTATORE: Consorzio Soci   		ITINERARIO NAPOLI – BARI RADDOPPIO TRATTA APICE – ORSARA I LOTTO FUNZIONALE APICE – HIRPINIA					
PROGETTAZIONE: Mandataria Mandanti   							
PROGETTO ESECUTIVO RELAZIONE DI CALCOLO FONDAZIONI SPALLA A							

Combinazione SLE (metodo AGI)						
L palo	τ_s calcolo	q_{ub} calcolo	$R_{c,s,k}$	$R_{c,b,k}$	ΔW palo	$Q_{c,s,k}/1.25$
m	kPa	kPa	kN	kN	kN	kN
1	48.0	286.3	226.2	505.8	26.5	154.4
2	48.0	572.5	452.4	1011.7	53.0	308.9
3	48.0	858.8	678.6	1517.5	79.5	463.3
4	48.0	1145.0	904.8	2023.4	106.0	617.8
5	48.0	1155.0	1131.0	2041.1	132.5	772.2
6	48.0	1165.0	1357.2	2058.7	159.0	926.7
7	48.0	1175.0	1583.4	2076.4	185.6	1081.1
8	48.0	1185.0	1809.6	2094.1	212.1	1235.6
9	48.0	1195.0	2035.8	2111.7	238.6	1390.0
10	48.0	1205.0	2261.9	2129.4	265.1	1544.5
11	48.0	1215.0	2488.1	2147.1	291.6	1698.9
11	48.0	1215.0	2488.1	2147.1	291.6	1698.9
12	118.6	1749.8	3047.0	3092.1	318.1	2119.5
13	118.6	2284.6	3605.8	4037.1	344.6	2540.0
14	118.6	2819.3	4164.6	4982.2	371.1	2960.6
15	118.6	3354.1	4723.4	5927.2	397.6	3381.1
16	118.6	3354.1	5282.2	5927.2	424.1	3801.7
17	118.6	3354.1	5841.1	5927.2	450.6	4222.2
18	118.6	3354.1	6399.9	5927.2	477.1	4642.8
19	118.6	3354.1	6958.7	5927.2	503.6	5063.3
20	118.6	3354.1	7517.5	5927.2	530.1	5483.9
21	118.6	3354.1	8076.3	5927.2	556.7	5904.4
21	118.6	3354.1	8076.3	5927.2	556.7	5904.4
22	140.3	3507.7	8737.6	6198.7	583.2	6406.9
23	140.3	3661.4	9398.8	6470.2	609.7	6909.3
24	140.3	3815.0	10060.0	6741.7	636.2	7411.8
25	140.3	3968.6	10721.2	7013.1	662.7	7914.3
26	140.3	3968.6	11382.4	7013.1	689.2	8416.7
27	140.3	3968.6	12043.6	7013.1	715.7	8919.2
28	140.3	3968.6	12704.8	7013.1	742.2	9421.6
29	140.3	3968.6	13366.0	7013.1	768.7	9924.1
30	140.3	3968.6	14027.2	7013.1	795.2	10426.5
31	140.3	3968.6	14688.4	7013.1	821.7	10929.0
32	140.3	3968.6	15349.6	7013.1	848.2	11431.5
33	140.3	3968.6	16010.8	7013.1	874.7	11933.9
34	140.3	3968.6	16672.0	7013.1	901.2	12436.4
35	140.3	3968.6	17333.2	7013.1	927.8	12938.8
36	140.3	3968.6	17994.4	7013.1	954.3	13441.3
37	140.3	3968.6	18655.6	7013.1	980.8	13943.7
38	140.3	3968.6	19316.8	7013.1	1007.3	14446.2
39	140.3	3968.6	19978.0	7013.1	1033.8	14948.7
40	140.3	3968.6	20639.3	7013.1	1060.3	15451.1

APPALTATORE: Consorzio Soci   		ITINERARIO NAPOLI – BARI					
PROGETTAZIONE: Mandataria Mandanti   		RADDOPPIO TRATTA APICE – ORSARA I LOTTO FUNZIONALE APICE – HIRPINIA					
PROGETTO ESECUTIVO RELAZIONE DI CALCOLO FONDAZIONI SPALLA A		COMMESSA IF1N	LOTTO 01 E ZZ	CODIFICA RG	DOCUMENTO MD0000 001	REV. B	FOGLIO 38 di 109

Combinazione SLU A1+M1+R3 (metodo AGI)						
L palo	Q i-c,k	Q b-c,k	Q i-c,d	Q b-c,d	ΔW palo	Q _{c,d}
m	kN	kN	kN	kN	kN	kN
1	226.2	505.8	122.9	234.2	34.5	322.7
2	452.4	1011.7	245.9	468.4	68.9	645.3
3	678.6	1517.5	368.8	702.6	103.4	968.0
4	904.8	2023.4	491.7	936.8	137.8	1290.6
5	1131.0	2041.1	614.7	944.9	172.3	1387.3
6	1357.2	2058.7	737.6	953.1	206.8	1483.9
7	1583.4	2076.4	860.5	961.3	241.2	1580.6
8	1809.6	2094.1	983.5	969.5	275.7	1677.3
9	2035.8	2111.7	1106.4	977.7	310.1	1773.9
10	2261.9	2129.4	1229.3	985.8	344.6	1870.6
11	2488.1	2147.1	1352.3	994.0	379.1	1967.2
11	2488.1	2147.1	1352.3	994.0	379.1	1967.2
12	3047.0	3092.1	1656.0	1431.5	413.5	2674.0
13	3605.8	4037.1	1959.7	1869.0	448.0	3380.7
14	4164.6	4982.2	2263.4	2306.6	482.4	4087.5
15	4723.4	5927.2	2567.1	2744.1	516.9	4794.3
16	5282.2	5927.2	2870.8	2744.1	551.3	5063.5
17	5841.1	5927.2	3174.5	2744.1	585.8	5332.8
18	6399.9	5927.2	3478.2	2744.1	620.3	5602.0
19	6958.7	5927.2	3781.9	2744.1	654.7	5871.2
20	7517.5	5927.2	4085.6	2744.1	689.2	6140.5
21	8076.3	5927.2	4389.3	2744.1	723.6	6409.7
21	8076.3	5927.2	4389.3	2744.1	723.6	6409.7
22	8737.6	6198.7	4748.7	2869.8	758.1	6860.3
23	9398.8	6470.2	5108.0	2995.4	792.6	7310.9
24	10060.0	6741.7	5467.4	3121.1	827.0	7761.5
25	10721.2	7013.1	5826.7	3246.8	861.5	8212.1
26	11382.4	7013.1	6186.1	3246.8	895.9	8537.0
27	12043.6	7013.1	6545.4	3246.8	930.4	8861.8
28	12704.8	7013.1	6904.8	3246.8	964.9	9186.7
29	13366.0	7013.1	7264.1	3246.8	999.3	9511.6
30	14027.2	7013.1	7623.5	3246.8	1033.8	9836.5
31	14688.4	7013.1	7982.8	3246.8	1068.2	10161.4
32	15349.6	7013.1	8342.2	3246.8	1102.7	10486.3
33	16010.8	7013.1	8701.5	3246.8	1137.2	10811.2
34	16672.0	7013.1	9060.9	3246.8	1171.6	11136.1
35	17333.2	7013.1	9420.2	3246.8	1206.1	11461.0
36	17994.4	7013.1	9779.6	3246.8	1240.5	11785.9
37	18655.6	7013.1	10138.9	3246.8	1275.0	12110.8
38	19316.8	7013.1	10498.3	3246.8	1309.5	12435.7
39	19978.0	7013.1	10857.6	3246.8	1343.9	12760.5
40	20639.3	7013.1	11217.0	3246.8	1378.4	13085.4

Comb. SLV A1+M1+R3 (metodo AGI)				
L palo	Q i-t,k	Q i-t,d	ΔW palo	Q _{t,d}
m	kN	kN	kN	kN
1	226.2	113.1	26.5	139.6
2	452.4	226.2	53.0	279.2
3	678.6	339.3	79.5	418.8
4	904.8	452.4	106.0	558.4
5	1131.0	565.5	132.5	698.0
6	1357.2	678.6	159.0	837.6
7	1583.4	791.7	185.6	977.2
8	1809.6	904.8	212.1	1116.8
9	2035.8	1017.9	238.6	1256.4
10	2261.9	1131.0	265.1	1396.0
11	2488.1	1244.1	291.6	1535.6
11	2488.1	1244.1	291.6	1535.6
12	3047.0	1523.5	318.1	1841.6
13	3605.8	1802.9	344.6	2147.5
14	4164.6	2082.3	371.1	2453.4
15	4723.4	2361.7	397.6	2759.3
16	5282.2	2641.1	424.1	3065.2
17	5841.1	2920.5	450.6	3371.2
18	6399.9	3199.9	477.1	3677.1
19	6958.7	3479.4	503.6	3983.0
20	7517.5	3758.8	530.1	4288.9
21	8076.3	4038.2	556.7	4594.8
21	8076.3	4038.2	556.7	4594.8
22	8737.6	4368.8	583.2	4919.9
23	9398.8	4699.4	609.7	5309.0
24	10060.0	5030.0	636.2	5666.2
25	10721.2	5360.6	662.7	6023.3
26	11382.4	5691.2	689.2	6380.4
27	12043.6	6021.8	715.7	6737.5
28	12704.8	6352.4	742.2	7094.6
29	13366.0	6683.0	768.7	7451.7
30	14027.2	7013.6	795.2	7808.8
31	14688.4	7344.2	821.7	8165.9
32	15349.6	7674.8	848.2	8523.0
33	16010.8	8005.4	874.7	8880.1
34	16672.0	8336.0	901.2	9237.3
35	17333.2	8666.6	927.8	9594.4
36	17994.4	8997.2	954.3	9951.5
37	18655.6	9327.8	980.8	10308.6
38	19316.8	9658.4	1007.3	10665.7
39	19978.0	9989.0	1033.8	11022.8
40	20639.3	10319.6	1060.3	11379.9

APPALTATORE: Consorzio Soci   	ITINERARIO NAPOLI – BARI					
PROGETTAZIONE: Mandataria Mandanti   	RADDOPPIO TRATTA APICE – ORSARA I LOTTO FUNZIONALE APICE – HIRPINIA					
PROGETTO ESECUTIVO RELAZIONE DI CALCOLO FONDAZIONI SPALLA A	COMMESSA IF1N	LOTTO 01 E ZZ	CODIFICA RG	DOCUMENTO MD0000 001	REV. B	FOGLIO 39 di 109



Figura 9-1: Capacità portante del palo singolo

APPALTATORE: Consorzio  Soci  	ITINERARIO NAPOLI – BARI RADDOPPIO TRATTA APICE – ORSARA I LOTTO FUNZIONALE APICE – HIRPINIA					
PROGETTAZIONE: Mandataria  Mandanti  						
PROGETTO ESECUTIVO RELAZIONE DI CALCOLO FONDAZIONI SPALLA A	COMMESSA IF1N	LOTTO 01 E ZZ	CODIFICA RG	DOCUMENTO MD0000 001	REV. B	FOGLIO 40 di 109

9.1.2 Verifica di capacità portante verticale del gruppo di pali

La verifica di capacità portante verticale del blocco è stata condotta in accordo ai criteri descritti nel documento di cui al Ref. 2) §7.1.

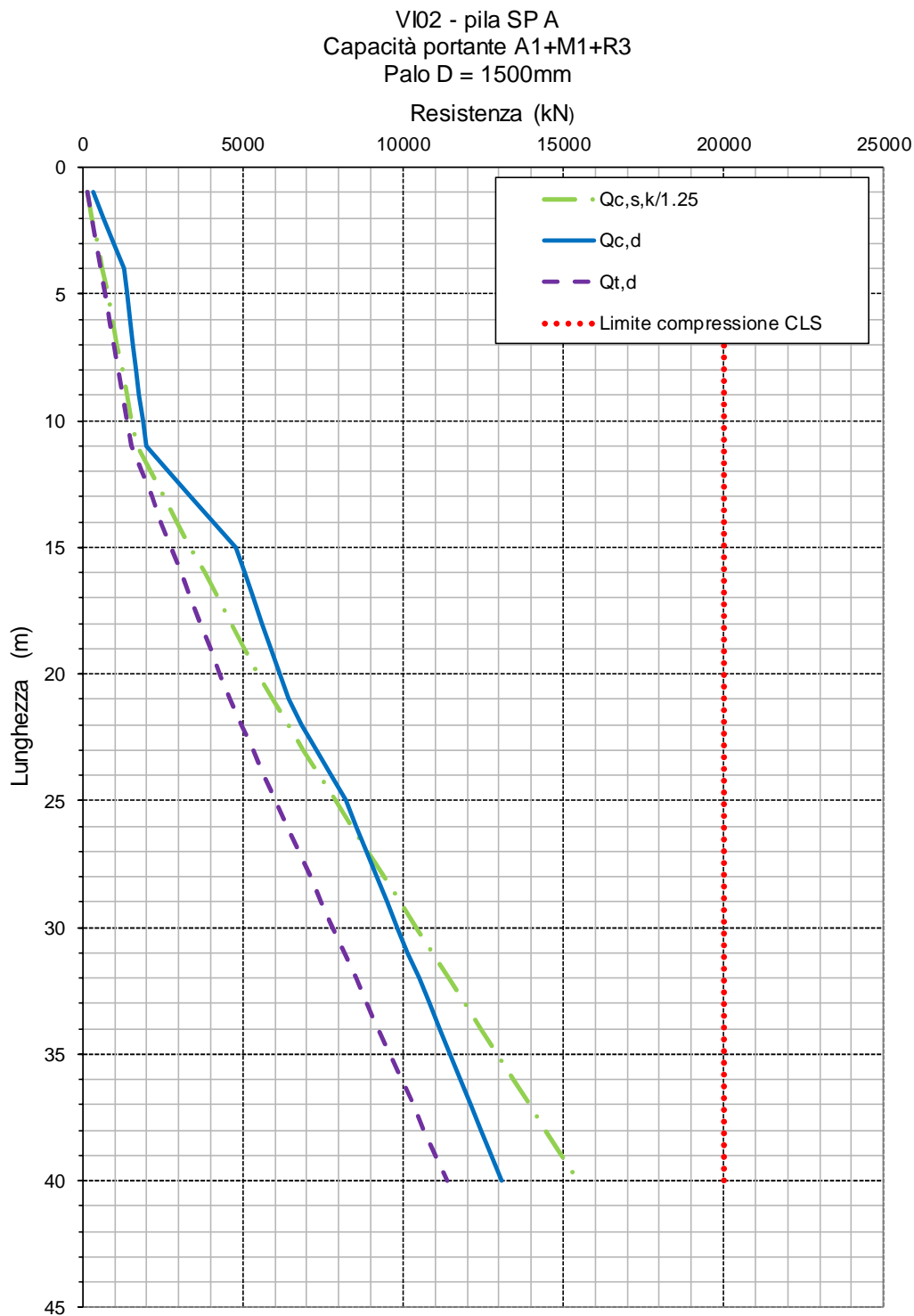
Nella seguente tabella si riporta la capacità portante del blocco valutata secondo l'Approccio 2 (A1+M1+R3).

CAPACITA' PORTANTE VERTICALE GRUPPI DI PALI

B	12			m	larghezza pozzo
L	21			m	lunghezza pozzo
D	22			m	profondità pozzo
i	4.5			m	interasse pali
n°	15				numero dei pali
γ_R cap.port.	2.3				coefficiente sicurezza globale per capacità portante
ξ_3	1.6				fattore di correlazione in base alle verticali indagate
γ_s	1.15				coefficiente di resistenza laterale
γ_b	1.35				coefficiente di resistenza base
$Cu_{b,calc}$	350			kPa	coesione non drenata di calcolo, base
$Cu_{b,d}$	162			kPa	coesione non drenata di progetto, base
$Cu_{s,i}$	120	250	350	kPa	coesione strato i
d_i	11	10	1	m	altezza strato i-esimo
$Cu_{s,calc}$	190			kPa	coesione non drenata di calcolo, laterale
$Cu_{s,d}$	103			kPa	coesione non drenata di progetto, laterale
A_s	1452			m ²	area laterale
A_b	252			m ²	area base
S_{block}	1				fattore forma
N_c	5.14				fattore di portanza alla base
$R_{block,c,d}$	156315			kN	resistenza di progetto
Valutazione alternativa dell'Area di Base					
$A_{b,diafr}$	26.5			m ²	area di impronta dei soli pali o pannelli
$R_{punz,c,d}$	74635			kN	Resistenza di progetto con area di base
Verifica:					
$N_{slu,max}$	46985			kN	
FS_{block}	3.33			ok	
FS_{punz}	1.59			ok	

Tabella 21: Capacità portante del blocco (Approccio 2: A1+M1+R3)

APPALTATORE: Consorzio Soci   	ITINERARIO NAPOLI – BARI RADDOPPIO TRATTA APICE – ORSARA I LOTTO FUNZIONALE APICE – HIRPINIA												
PROGETTAZIONE: Mandataria Mandanti   													
PROGETTO ESECUTIVO RELAZIONE DI CALCOLO FONDAZIONI SPALLA A	<table border="1" style="width: 100%; border-collapse: collapse;"> <tr> <td style="text-align: center;">COMMESSA</td> <td style="text-align: center;">LOTTO</td> <td style="text-align: center;">CODIFICA</td> <td style="text-align: center;">DOCUMENTO</td> <td style="text-align: center;">REV.</td> <td style="text-align: center;">FOGLIO</td> </tr> <tr> <td style="text-align: center;">IF1N</td> <td style="text-align: center;">01 E ZZ</td> <td style="text-align: center;">RG</td> <td style="text-align: center;">MD0000 001</td> <td style="text-align: center;">B</td> <td style="text-align: center;">41 di 109</td> </tr> </table>	COMMESSA	LOTTO	CODIFICA	DOCUMENTO	REV.	FOGLIO	IF1N	01 E ZZ	RG	MD0000 001	B	41 di 109
COMMESSA	LOTTO	CODIFICA	DOCUMENTO	REV.	FOGLIO								
IF1N	01 E ZZ	RG	MD0000 001	B	41 di 109								

9.1.1 Verifica di capacità portante orizzontale del gruppo di pali

La verifica di capacità portante orizzontale del gruppo di pali è stata condotta con i criteri descritti nel documento di cui al Ref. 2) §6.2, con i metodi basati sulle curve p-y.

Considerata la presenza di successioni stratigrafiche abbastanza articolate, con contrasti di rigidezza anche marcati e caratteristiche diverse delle varie unità geotecniche, si è fatto uso del programma FEM non lineare LPile, considerando negli strati di terreno curve p-y non lineari, definibili lungo il fuso del palo, e opportunamente ridotte secondo il coefficiente parziale $\xi \times \gamma_T$.

Si ricava una curva “pushover” del palo singolo: incrementando progressivamente il carico orizzontale applicato alla testa del palo, fino al raggiungimento del collasso, vale a dire della completa plasticizzazione del terreno. Tale plasticizzazione si rende “visibile” attraverso il cambiamento del comportamento deformativo del palo stesso, al raggiungimento del “plateau” di resistenza.

Nella seguente Figura 9-2 è illustrata la curva push-over ottenuta per il palo in oggetto, con il vincolo di invastro, al crescere dell’azione H applicata alla testa dello stesso.

Il taglio massimo agente è pari a $T_{longSLV} \approx 1968.1$ kN.

La verifica a capacità portante orizzontale risulta soddisfatta, poiché il carico limite $H_{lim} = 3271.0$ kN risulta superiore al valore di progetto.





Figura 9-2: Analisi push-over palo

<p>APPALTATORE:</p> <p>Consortio Soci</p> <p>  </p>	<p>ITINERARIO NAPOLI – BARI</p> <p>RADDOPPIO TRATTA APICE – ORSARA</p> <p>I LOTTO FUNZIONALE APICE – HIRPINIA</p>																	
<p>PROGETTAZIONE:</p> <p>Mandataria Mandanti</p> <p>  </p>							<table border="1" style="width: 100%; border-collapse: collapse;"> <tr> <td style="width: 16.6%;">COMMESSA</td> <td style="width: 16.6%;">LOTTO</td> <td style="width: 16.6%;">CODIFICA</td> <td style="width: 16.6%;">DOCUMENTO</td> <td style="width: 16.6%;">REV.</td> <td style="width: 16.6%;">FOGLIO</td> </tr> <tr> <td style="text-align: center;">IF1N</td> <td style="text-align: center;">01 E ZZ</td> <td style="text-align: center;">RG</td> <td style="text-align: center;">MD0000 001</td> <td style="text-align: center;">B</td> <td style="text-align: center;">42 di 109</td> </tr> </table>						COMMESSA	LOTTO	CODIFICA	DOCUMENTO	REV.	FOGLIO
COMMESSA	LOTTO	CODIFICA	DOCUMENTO	REV.	FOGLIO													
IF1N	01 E ZZ	RG	MD0000 001	B	42 di 109													

PROGETTO ESECUTIVO
RELAZIONE DI CALCOLO FONDAZIONI SPALLA A

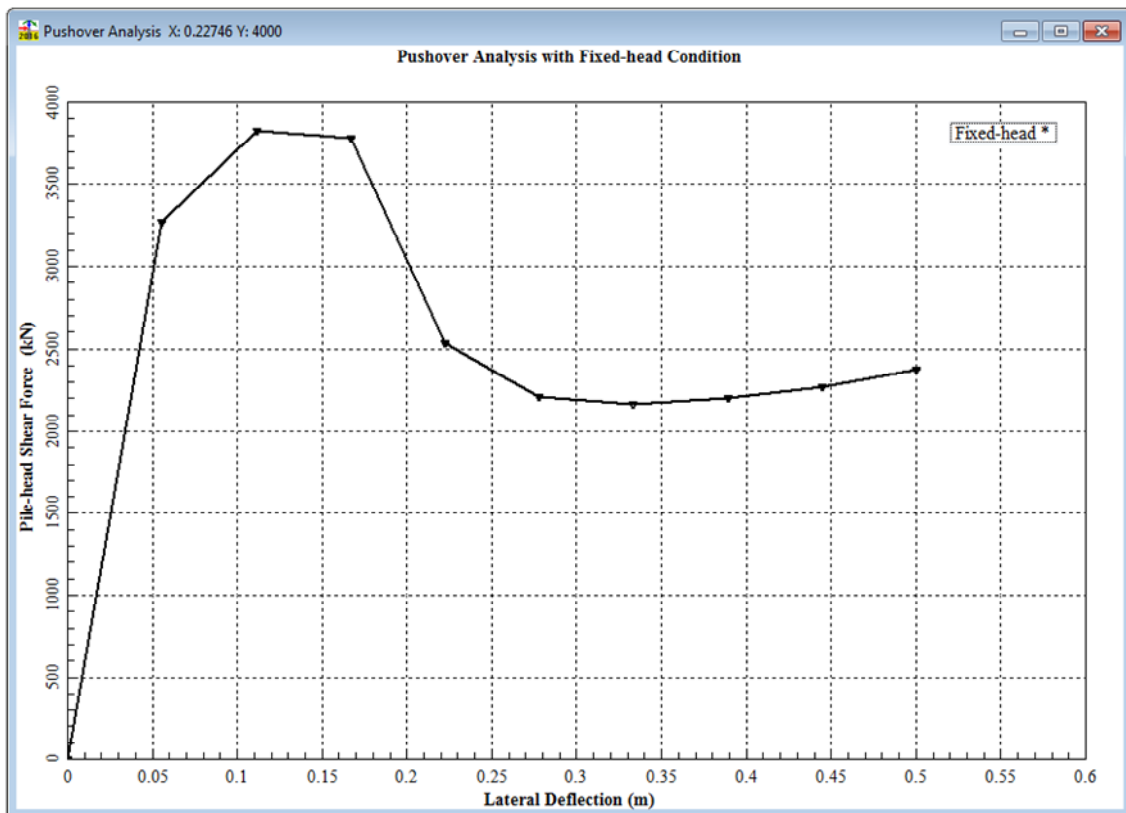
APPALTATORE: Consorzio Soci   	ITINERARIO NAPOLI – BARI RADDOPPIO TRATTA APICE – ORSARA I LOTTO FUNZIONALE APICE – HIRPINIA					
PROGETTAZIONE: Mandataria Mandanti   						
PROGETTO ESECUTIVO RELAZIONE DI CALCOLO FONDAZIONI SPALLA A	COMMESSA IF1N	LOTTO 01 E ZZ	CODIFICA RG	DOCUMENTO MD0000 001	REV. B	FOGLIO 43 di 109

10 ALLEGATO: TABULATI GROUP

10.1 SPALLA SLE

=====

GROUP for Windows, Version 2016.10.13

Serial Number : 228330872

Analysis of A Group of Piles
 Subjected to Axial and Lateral Loading

(c) Copyright ENSOFT, Inc., 1987-2015
 All Rights Reserved

=====

 Time and Date of Analysis

Date: February 07, 2020 Time: 10:13:01

***** COMPUTATION RESULTS *****

New Group

***** LOAD CASES RESULTS *****

LOAD CASE : 1
 CASE NAME : Load Case
 LOAD TYPE : Special, Sp

REDUCTION FACTORS FOR CLOSELY-SPACED PILE GROUPS, COMBINED Y AND Z DIRECTIONS
 ESTIMATED USING MOVEMENT IN THE DIRECTION OF PILE CAP DISPLACEMENTS

GROUP NO	P-FACTOR	Y-FACTOR
1	0.7960	1.0000
2	0.5568	1.0000
3	0.5845	1.0000
4	0.7403	1.0000
5	0.4860	1.0000
6	0.5100	1.0000
7	0.7478	1.0000
8	0.4954	1.0000
9	0.5207	1.0000
10	0.8661	1.0000
11	0.6517	1.0000
12	0.6769	1.0000

* TABLE L * COMPUTATION ON PILE CAP

* EQUIVALENT CONCENTRATED LOAD AT ORIGIN *

VERT. LOAD, KN	HOR. LOAD Y, KN	HOR. LOAD Z, KN
43857.0	2060.00	-1440.00
MOMENT X, KN- M	MOMENT Y, KN- M	MOMENT Z, KN- M
-295.000	-23215.0	-24496.0

* DISPLACEMENT OF GROUPED PILE FOUNDATION AT ORIGIN *

APPALTATORE: Consorzio  Soci  	ITINERARIO NAPOLI – BARI RADDOPPIO TRATTA APICE – ORSARA I LOTTO FUNZIONALE APICE – HIRPINIA						
PROGETTAZIONE: Mandataria  Mandanti  							
PROGETTO ESECUTIVO RELAZIONE DI CALCOLO FONDAZIONI SPALLA A	<table border="1"> <tr> <td>COMMESSA IF1N</td> <td>LOTTO 01 E ZZ</td> <td>CODIFICA RG</td> <td>DOCUMENTO MD0000 001</td> <td>REV. B</td> <td>FOGLIO 44 di 109</td> </tr> </table>	COMMESSA IF1N	LOTTO 01 E ZZ	CODIFICA RG	DOCUMENTO MD0000 001	REV. B	FOGLIO 44 di 109
COMMESSA IF1N	LOTTO 01 E ZZ	CODIFICA RG	DOCUMENTO MD0000 001	REV. B	FOGLIO 44 di 109		

VERTICAL , M 1.87510E-03	HORIZONTAL Y, M 7.78671E-04	HORIZONTAL Z, M -4.91944E-04
ANGLE ROT. X,RAD -9.26210E-07	ANGLE ROT. Y,RAD -4.56480E-05	ANGLE ROT. Z,RAD -9.25026E-05

THE GLOBAL STRUCTURAL COORDINATE SYSTEM

* PILE TOP DISPLACEMENTS *

PILE GROUP	DISP. X, M	DISP. Y, M	DISP. Z, M	ROT. X,RAD	ROT. Y,RAD	ROT. Z,RAD
*****	*****	*****	*****	*****	*****	*****
1	1.9832E-03	7.8492E-04	-4.9611E-04	-9.2621E-07	-4.5648E-05	-9.2503E-05
2	1.5670E-03	7.8492E-04	-4.9194E-04	-9.2621E-07	-4.5648E-05	-9.2503E-05
3	1.1507E-03	7.8492E-04	-4.8778E-04	-9.2621E-07	-4.5648E-05	-9.2503E-05
4	2.1887E-03	7.8075E-04	-4.9611E-04	-9.2621E-07	-4.5648E-05	-9.2503E-05
5	1.7724E-03	7.8075E-04	-4.9194E-04	-9.2621E-07	-4.5648E-05	-9.2503E-05
6	1.3561E-03	7.8075E-04	-4.8778E-04	-9.2621E-07	-4.5648E-05	-9.2503E-05
7	2.3941E-03	7.7659E-04	-4.9611E-04	-9.2621E-07	-4.5648E-05	-9.2503E-05
8	1.9778E-03	7.7659E-04	-4.9194E-04	-9.2621E-07	-4.5648E-05	-9.2503E-05
9	1.5616E-03	7.7659E-04	-4.8778E-04	-9.2621E-07	-4.5648E-05	-9.2503E-05
10	2.5995E-03	7.7242E-04	-4.9611E-04	-9.2621E-07	-4.5648E-05	-9.2503E-05
11	2.1832E-03	7.7242E-04	-4.9194E-04	-9.2621E-07	-4.5648E-05	-9.2503E-05
12	1.7670E-03	7.7242E-04	-4.8778E-04	-9.2621E-07	-4.5648E-05	-9.2503E-05
MINIMUM	1.1507E-03	7.7242E-04	-4.9611E-04	-9.2621E-07	-4.5648E-05	-9.2503E-05
Pile N.	3	10	1	1	1	1
MAXIMUM	2.5995E-03	7.8492E-04	-4.8778E-04	-9.2621E-07	-4.5648E-05	-9.2503E-05
Pile N.	10	1	3	1	1	1

* PILE TOP REACTIONS *

PILE GROUP	FOR. X, KN	FOR. Y, KN	FOR. Z, KN	MOM X, KN- M	MOM Y, KN- M	MOM Z, KN- M
*****	*****	*****	*****	*****	*****	*****
1	3860.0	203.78	-141.39	-0.2459	297.52	386.51
2	3069.8	159.16	-110.24	-0.2459	242.02	310.08
3	2279.6	164.73	-112.64	-0.2459	244.90	319.69
4	4250.0	192.33	-134.73	-0.2459	286.32	366.04
5	3459.8	143.50	-100.60	-0.2459	224.57	280.90
6	2669.5	148.51	-102.76	-0.2459	227.17	289.73
7	4640.0	192.12	-135.60	-0.2459	287.86	364.31
8	3849.7	144.23	-101.88	-0.2459	226.98	281.05
9	3059.5	149.45	-104.19	-0.2459	229.83	290.23
10	5029.9	210.88	-149.42	-0.2459	311.06	393.85
11	4239.7	173.30	-122.39	-0.2459	263.67	330.91
12	3449.5	178.01	-124.16	-0.2459	265.26	338.78
MINIMUM	2279.6	143.50	-149.42	-0.2459	224.57	280.90
Pile N.	3	5	10	1	5	5
MAXIMUM	5029.9	210.88	-100.60	-0.2459	311.06	393.85
Pile N.	10	10	5	1	10	10

THE PILE COORDINATE SYSTEM (LOCAL AXES)

* PILE TOP DISPLACEMENTS *

PILE GROUP	DISP. x, M	DISP. y, M	DISP. z, M	ROT. x,RAD	ROT. y,RAD	ROT. z,RAD
*****	*****	*****	*****	*****	*****	*****
1	1.9832E-03	7.8492E-04	-4.9611E-04	-9.2621E-07	-4.5648E-05	-9.2503E-05
2	1.5670E-03	7.8492E-04	-4.9194E-04	-9.2621E-07	-4.5648E-05	-9.2503E-05
3	1.1507E-03	7.8492E-04	-4.8778E-04	-9.2621E-07	-4.5648E-05	-9.2503E-05
4	2.1887E-03	7.8075E-04	-4.9611E-04	-9.2621E-07	-4.5648E-05	-9.2503E-05
5	1.7724E-03	7.8075E-04	-4.9194E-04	-9.2621E-07	-4.5648E-05	-9.2503E-05
6	1.3561E-03	7.8075E-04	-4.8778E-04	-9.2621E-07	-4.5648E-05	-9.2503E-05
7	2.3941E-03	7.7659E-04	-4.9611E-04	-9.2621E-07	-4.5648E-05	-9.2503E-05
8	1.9778E-03	7.7659E-04	-4.9194E-04	-9.2621E-07	-4.5648E-05	-9.2503E-05
9	1.5616E-03	7.7659E-04	-4.8778E-04	-9.2621E-07	-4.5648E-05	-9.2503E-05
10	2.5995E-03	7.7242E-04	-4.9611E-04	-9.2621E-07	-4.5648E-05	-9.2503E-05
11	2.1832E-03	7.7242E-04	-4.9194E-04	-9.2621E-07	-4.5648E-05	-9.2503E-05
12	1.7670E-03	7.7242E-04	-4.8778E-04	-9.2621E-07	-4.5648E-05	-9.2503E-05
MINIMUM	1.1507E-03	7.7242E-04	-4.9611E-04	-9.2621E-07	-4.5648E-05	-9.2503E-05
Pile N.	3	10	1	1	1	1
MAXIMUM	2.5995E-03	7.8492E-04	-4.8778E-04	-9.2621E-07	-4.5648E-05	-9.2503E-05
Pile N.	10	1	3	1	1	1

* PILE TOP REACTIONS *

PILE GROUP	AXIAL, KN	LAT. y, KN	LAT. z, KN	MOM x, KN- M	MOM y, KN- M	MOM z, KN- M
*****	*****	*****	*****	*****	*****	*****
1	3860.0	203.78	-141.39	-0.2459	297.52	386.51
2	3069.8	159.16	-110.24	-0.2459	242.02	310.08
3	2279.6	164.73	-112.64	-0.2459	244.90	319.69
4	4250.0	192.33	-134.73	-0.2459	286.32	366.04

APPALTATORE:

Consorzio

Soci



ITINERARIO NAPOLI – BARI

PROGETTAZIONE:

Mandataria

Mandanti



RADDOPPIO TRATTA APICE – ORSARA
I LOTTO FUNZIONALE APICE – HIRPINIA

PROGETTO ESECUTIVO

RELAZIONE DI CALCOLO FONDAZIONI SPALLA A

COMMESSA

LOTTO

CODIFICA

DOCUMENTO

REV.

FOGLIO

IF1N

01 E ZZ

RG

MD0000 001

B

45 di 109

5	3459.8	143.50	-100.60	-0.2459	224.57	280.90
6	2669.5	148.51	-102.76	-0.2459	227.17	289.73
7	4640.0	192.12	-135.60	-0.2459	287.86	364.31
8	3849.7	144.23	-101.88	-0.2459	226.98	281.05
9	3059.5	149.45	-104.19	-0.2459	229.83	290.23
10	5029.9	210.88	-149.42	-0.2459	311.06	393.85
11	4239.7	173.30	-122.39	-0.2459	263.67	330.91
12	3449.5	178.01	-124.16	-0.2459	265.26	338.78
MINIMUM	2279.6	143.50	-149.42	-0.2459	224.57	280.90
Pile N.	3	5	10	1	5	5
MAXIMUM	5029.9	210.88	-100.60	-0.2459	311.06	393.85
Pile N.	10	10	5	1	10	10

PILE GROUP STRESS, KN/ M**2

*****	*****
1	3656.4
2	2924.3
3	2505.4
4	3807.5
5	3043.2
6	2621.8
7	4027.0
8	3268.8
9	2848.6
10	4361.0
11	3676.1
12	3250.6
MINIMUM	2505.4
Pile N.	3
MAXIMUM	4361.0
Pile N.	10

* EFFECTS FOR LATERALLY LOADED PILE *

* MINIMUM VALUES AND LOCATIONS *

PILE	DISPL. y-DIR	DISPL. z-DIR	MOMENT z-DIR	MOMENT y-DIR	SHEAR y-DIR	SHEAR z-DIR	SOIL REACT y-DIR	SOIL REACT z-DIR	TOTAL STRESS	FLEX. RIG. z-DIR	FLEX. RIG. y-DIR
	M	M	KN- M	KN- M	KN	KN	KN/ M	KN/ M	KN/ M**2	KN- M**2	KN- M**2
1	-1.1210E-05	-4.9611E-04	-386.51	-132.81	-45.194	-141.41	-19.628	-34.689	2184.3	7.8279E+06	7.8279E+06
x(M)	9.9900	0.0000	0.0000	5.4000	8.3700	0.0000	10.260	2.9700	27.000	0.0000	0.0000
2	-9.4559E-06	-4.9194E-04	-310.08	-114.38	-37.690	-110.25	-12.509	-25.440	1737.2	7.8279E+06	7.8279E+06
x(M)	10.800	0.0000	0.0000	5.6700	8.9100	0.0000	10.800	3.2400	27.000	0.0000	0.0000
3	-9.6577E-06	-4.8778E-04	-319.69	-115.65	-38.614	-112.65	-13.254	-26.230	1290.0	7.8279E+06	7.8279E+06
x(M)	10.530	0.0000	0.0000	5.6700	8.9100	0.0000	10.800	3.2400	27.000	0.0000	0.0000
4	-1.0766E-05	-4.9611E-04	-366.04	-129.01	-43.348	-134.75	-17.828	-32.620	2405.0	7.8279E+06	7.8279E+06
x(M)	9.9900	0.0000	0.0000	5.4000	8.3700	0.0000	10.260	2.9700	27.000	0.0000	0.0000
5	-9.0335E-06	-4.9194E-04	-280.90	-108.48	-34.966	-100.62	-10.693	-22.673	1957.8	7.8279E+06	7.8279E+06
x(M)	11.070	0.0000	0.0000	5.9400	9.1800	0.0000	11.070	3.2400	27.000	0.0000	0.0000
6	-9.1678E-06	-4.8778E-04	-289.73	-109.55	-35.819	-102.77	-11.285	-23.375	1510.7	7.8279E+06	7.8279E+06
x(M)	10.800	0.0000	0.0000	5.9400	9.1800	0.0000	11.070	3.2400	27.000	0.0000	0.0000
7	-1.0798E-05	-4.9611E-04	-364.31	-129.55	-43.347	-135.63	-18.002	-32.898	2625.7	7.8279E+06	7.8279E+06
x(M)	9.9900	0.0000	0.0000	5.4000	8.3700	0.0000	10.260	2.9700	27.000	0.0000	0.0000
8	-9.0565E-06	-4.9194E-04	-281.05	-109.30	-35.139	-101.90	-10.895	-23.044	2178.5	7.8279E+06	7.8279E+06
x(M)	10.800	0.0000	0.0000	5.9400	9.1800	0.0000	11.070	3.2400	27.000	0.0000	0.0000
9	-9.2069E-06	-4.8778E-04	-290.23	-110.44	-36.012	-104.20	-11.506	-23.792	1731.3	7.8279E+06	7.8279E+06
x(M)	10.800	0.0000	0.0000	5.9400	9.1800	0.0000	11.070	3.2400	27.000	0.0000	0.0000
10	-1.1640E-05	-4.9611E-04	-393.85	-137.29	-46.456	-149.45	-21.414	-37.245	2846.3	7.8279E+06	7.8279E+06
x(M)	9.7200	0.0000	0.0000	5.4000	8.1000	0.0000	10.260	2.9700	27.000	0.0000	0.0000
11	-1.0049E-05	-4.9194E-04	-330.91	-121.77	-40.204	-122.41	-15.005	-29.019	2399.2	7.8279E+06	7.8279E+06
x(M)	10.260	0.0000	0.0000	5.6700	8.6400	0.0000	10.530	3.2400	27.000	0.0000	0.0000
12	-1.0217E-05	-4.8778E-04	-338.78	-122.47	-40.947	-124.18	-15.705	-29.641	1952.0	7.8279E+06	7.8279E+06
x(M)	10.260	0.0000	0.0000	5.6700	8.6400	0.0000	10.530	3.2400	27.000	0.0000	0.0000
Min.	-1.1640E-05	-4.9611E-04	-393.85	-137.29	-46.456	-149.45	-21.414	-37.245	1290.0	7.8279E+06	7.8279E+06
Pile N.	10	1	10	10	10	10	10	10	3	1	1

* MAXIMUM VALUES AND LOCATIONS *

PILE	DISPL. y-DIR	DISPL. z-DIR	MOMENT z-DIR	MOMENT y-DIR	SHEAR y-DIR	SHEAR z-DIR	SOIL REACT y-DIR	SOIL REACT z-DIR	TOTAL STRESS	FLEX. RIG. z-DIR	FLEX. RIG. y-DIR
	M	M	KN- M	KN- M	KN	KN	KN/ M	KN/ M	KN/ M**2	KN- M**2	KN- M**2
1	7.8492E-04	6.6281E-06	210.91	297.52	203.81	28.855	51.811	11.892	3656.4	7.8279E+06	7.8279E+06
x(M)	0.0000	9.9900	5.1300	0.0000	0.0000	8.6400	2.9700	10.260	0.0000	0.0000	0.0000
2	7.8492E-04	5.6096E-06	183.82	242.02	159.18	23.838	38.155	7.5834	2924.3	7.8279E+06	7.8279E+06
x(M)	0.0000	10.800	5.4000	0.0000	0.0000	9.1800	3.2400	11.070	0.0000	0.0000	0.0000
3	7.8492E-04	5.6714E-06	187.33	244.90	164.74	24.212	39.759	7.9422	2505.4	7.8279E+06	7.8279E+06
x(M)	0.0000	10.800	5.4000	0.0000	0.0000	9.1800	3.2400	11.070	0.0000	0.0000	0.0000
4	7.8076E-04	6.4068E-06	203.97	286.32	192.35	27.850	48.377	10.814	3807.5	7.8279E+06	7.8279E+06
x(M)	0.0000	10.260	5.4000	0.0000	0.0000	8.6400	2.9700	10.530	0.0000	0.0000	0.0000
5	7.8076E-04	5.4091E-06	173.75	224.57	143.52	22.193	33.751	6.5588	3043.2	7.8279E+06	7.8279E+06
x(M)	0.0000	11.340	5.6700	0.0000	0.0000	9.4500	3.2400	11.340	0.0000	0.0000	0.0000
6	7.8076E-04	5.4387E-06	176.87	227.17	148.52	22.551	35.168	6.8441	2621.8	7.8279E+06	7.8279E+06
x(M)	0.0000	11.070	5.6700	0.0000	0.0000	9.4500	3.2400	11.340	0.0000	0.0000	0.0000

APPALTATORE: Consorzio Soci   	ITINERARIO NAPOLI – BARI RADDOPPIO TRATTA APICE – ORSARA I LOTTO FUNZIONALE APICE – HIRPINIA				
PROGETTAZIONE: Mandataria Mandanti   					
PROGETTO ESECUTIVO RELAZIONE DI CALCOLO FONDAZIONI SPALLA A					
COMMESSA IF1N	LOTTO 01 E ZZ	CODIFICA RG	DOCUMENTO MD0000 001	REV. B	FOGLIO 46 di 109

7	7.7659E-04	6.4439E-06	203.74	287.86	192.14	28.001	48.460	10.956	4027.0	7.8279E+06	7.8279E+06
x(M)	0.0000	10.260	5.1300	0.0000	0.0000	8.6400	2.9700	10.530	0.0000	0.0000	0.0000
8	7.7659E-04	5.4384E-06	174.14	226.98	144.25	22.432	34.066	6.7008	3268.8	7.8279E+06	7.8279E+06
x(M)	0.0000	11.070	5.6700	0.0000	0.0000	9.4500	3.2400	11.340	0.0000	0.0000	0.0000
9	7.7659E-04	5.4733E-06	177.36	229.83	149.47	22.804	35.549	6.9962	2848.6	7.8279E+06	7.8279E+06
x(M)	0.0000	11.070	5.6700	0.0000	0.0000	9.4500	3.2400	11.340	0.0000	0.0000	0.0000
10	7.7242E-04	6.9841E-06	214.68	311.06	210.91	30.166	54.520	13.326	4361.0	7.8279E+06	7.8279E+06
x(M)	0.0000	9.9900	5.1300	0.0000	0.0000	8.3700	2.9700	10.260	0.0000	0.0000	0.0000
11	7.7242E-04	5.9857E-06	192.50	263.67	173.32	25.878	42.770	9.1353	3676.1	7.8279E+06	7.8279E+06
x(M)	0.0000	10.530	5.4000	0.0000	0.0000	8.9100	2.9700	10.800	0.0000	0.0000	0.0000
12	7.7242E-04	6.0321E-06	195.23	265.26	178.04	26.121	44.195	9.4647	3250.6	7.8279E+06	7.8279E+06
x(M)	0.0000	10.530	5.4000	0.0000	0.0000	8.9100	2.9700	10.800	0.0000	0.0000	0.0000
Max.	7.8492E-04	6.9841E-06	214.68	311.06	210.91	30.166	54.520	13.326	4361.0	7.8279E+06	7.8279E+06
Pile N.	1	10	10	10	10	10	10	10	10	1	1

LOAD CASE : 2
CASE NAME : Load Case
LOAD TYPE : Special, Sp

REDUCTION FACTORS FOR CLOSELY-SPACED PILE GROUPS, COMBINED Y AND Z DIRECTIONS
ESTIMATED USING MOVEMENT IN THE DIRECTION OF PILE CAP DISPLACEMENTS

GROUP NO	P-FACTOR	Y-FACTOR
1	0.6351	1.0000
2	0.5099	1.0000
3	0.5845	1.0000
4	0.5912	1.0000
5	0.4676	1.0000
6	0.5374	1.0000
7	0.6185	1.0000
8	0.4960	1.0000
9	0.5673	1.0000
10	0.8661	1.0000
11	0.7754	1.0000
12	0.8297	1.0000

* TABLE L * COMPUTATION ON PILE CAP

* EQUIVALENT CONCENTRATED LOAD AT ORIGIN *

VERT. LOAD, KN	HOR. LOAD Y, KN	HOR. LOAD Z, KN
33922.0	415.000	-1204.00
MOMENT X, KN- M	MOMENT Y, KN- M	MOMENT Z, KN- M
-335.000	-18699.0	-6629.50

* DISPLACEMENT OF GROUPED PILE FOUNDATION AT ORIGIN *

VERTICAL, M	HORIZONTAL Y, M	HORIZONTAL Z, M
1.43899E-03	1.73799E-04	-4.12259E-04
ANGLE ROT. X, RAD	ANGLE ROT. Y, RAD	ANGLE ROT. Z, RAD
-2.77772E-06	-3.69954E-05	-2.38671E-05

THE GLOBAL STRUCTURAL COORDINATE SYSTEM

* PILE TOP DISPLACEMENTS *

PILE GROUP	DISP. X, M	DISP. Y, M	DISP. Z, M	ROT. X, RAD	ROT. Y, RAD	ROT. Z, RAD
*****	*****	*****	*****	*****	*****	*****
1	1.2967E-03	1.9255E-04	-4.2476E-04	-2.7777E-06	-3.6995E-05	-2.3867E-05
2	1.1893E-03	1.9255E-04	-4.1226E-04	-2.7777E-06	-3.6995E-05	-2.3867E-05
3	1.0819E-03	1.9255E-04	-3.9976E-04	-2.7777E-06	-3.6995E-05	-2.3867E-05
4	1.4632E-03	1.8005E-04	-4.2476E-04	-2.7777E-06	-3.6995E-05	-2.3867E-05
5	1.3557E-03	1.8005E-04	-4.1226E-04	-2.7777E-06	-3.6995E-05	-2.3867E-05
6	1.2483E-03	1.8005E-04	-3.9976E-04	-2.7777E-06	-3.6995E-05	-2.3867E-05
7	1.6296E-03	1.6755E-04	-4.2476E-04	-2.7777E-06	-3.6995E-05	-2.3867E-05
8	1.5222E-03	1.6755E-04	-4.1226E-04	-2.7777E-06	-3.6995E-05	-2.3867E-05
9	1.4148E-03	1.6755E-04	-3.9976E-04	-2.7777E-06	-3.6995E-05	-2.3867E-05
10	1.7961E-03	1.5505E-04	-4.2476E-04	-2.7777E-06	-3.6995E-05	-2.3867E-05
11	1.6887E-03	1.5505E-04	-4.1226E-04	-2.7777E-06	-3.6995E-05	-2.3867E-05
12	1.5813E-03	1.5505E-04	-3.9976E-04	-2.7777E-06	-3.6995E-05	-2.3867E-05
MINIMUM	1.0819E-03	1.5505E-04	-4.2476E-04	-2.7777E-06	-3.6995E-05	-2.3867E-05
Pile N.	3	10	1	1	1	1
MAXIMUM	1.7961E-03	1.9255E-04	-3.9976E-04	-2.7777E-06	-3.6995E-05	-2.3867E-05

APPALTATORE:

Consorzio

Soci



ITINERARIO NAPOLI – BARI

PROGETTAZIONE:

Mandataria

Mandanti

RADDOPPIO TRATTA APICE – ORSARA
I LOTTO FUNZIONALE APICE – HIRPINIA

PROGETTO ESECUTIVO

RELAZIONE DI CALCOLO FONDAZIONI SPALLA A

COMMESSA
IF1NLOTTO
01 E ZZCODIFICA
RGDOCUMENTO
MD0000 001REV.
BFOGLIO
47 di 109

Pile N. 10 1 3 1 1 1

* PILE TOP REACTIONS *

PILE GROUP	FOR. X, KN	FOR. Y, KN	FOR. Z, KN	MOM X, KN- M	MOM Y, KN- M	MOM Z, KN- M
1	2556.7	41.747	-106.13	-0.7376	234.07	77.928
2	2352.8	35.762	-88.157	-0.7376	198.00	67.431
3	2148.9	39.394	-92.681	-0.7376	202.33	73.828
4	2872.7	35.766	-101.21	-0.7376	225.39	63.501
5	2668.8	30.208	-83.175	-0.7376	188.88	53.673
6	2464.9	33.405	-87.588	-0.7376	193.24	59.357
7	3188.7	32.897	-104.26	-0.7376	230.85	54.435
8	2984.9	27.985	-86.512	-0.7376	195.07	45.889
9	2781.0	30.892	-90.808	-0.7376	199.06	50.968
10	3504.8	36.981	-130.14	-0.7376	275.10	56.663
11	3300.9	34.112	-116.41	-0.7376	247.69	52.041
12	3097.0	35.851	-116.93	-0.7376	244.13	54.836
MINIMUM	2148.9	27.985	-130.14	-0.7376	188.88	45.889
Pile N.	3	8	10	1	5	8
MAXIMUM	3504.8	41.747	-83.175	-0.7376	275.10	77.928
Pile N.	10	1	5	1	10	1

THE PILE COORDINATE SYSTEM (LOCAL AXES)

* PILE TOP DISPLACEMENTS *

PILE GROUP	DISP. x, M	DISP. y, M	DISP. z, M	ROT. x,RAD	ROT. y,RAD	ROT. z,RAD
1	1.2967E-03	1.9255E-04	-4.2476E-04	-2.7777E-06	-3.6995E-05	-2.3867E-05
2	1.1893E-03	1.9255E-04	-4.1226E-04	-2.7777E-06	-3.6995E-05	-2.3867E-05
3	1.0819E-03	1.9255E-04	-3.9976E-04	-2.7777E-06	-3.6995E-05	-2.3867E-05
4	1.4632E-03	1.8005E-04	-4.2476E-04	-2.7777E-06	-3.6995E-05	-2.3867E-05
5	1.3557E-03	1.8005E-04	-4.1226E-04	-2.7777E-06	-3.6995E-05	-2.3867E-05
6	1.2483E-03	1.8005E-04	-3.9976E-04	-2.7777E-06	-3.6995E-05	-2.3867E-05
7	1.6296E-03	1.6755E-04	-4.2476E-04	-2.7777E-06	-3.6995E-05	-2.3867E-05
8	1.5222E-03	1.6755E-04	-4.1226E-04	-2.7777E-06	-3.6995E-05	-2.3867E-05
9	1.4148E-03	1.6755E-04	-3.9976E-04	-2.7777E-06	-3.6995E-05	-2.3867E-05
10	1.7961E-03	1.5505E-04	-4.2476E-04	-2.7777E-06	-3.6995E-05	-2.3867E-05
11	1.6887E-03	1.5505E-04	-4.1226E-04	-2.7777E-06	-3.6995E-05	-2.3867E-05
12	1.5813E-03	1.5505E-04	-3.9976E-04	-2.7777E-06	-3.6995E-05	-2.3867E-05
MINIMUM	1.0819E-03	1.5505E-04	-4.2476E-04	-2.7777E-06	-3.6995E-05	-2.3867E-05
Pile N.	3	10	1	1	1	1
MAXIMUM	1.7961E-03	1.9255E-04	-3.9976E-04	-2.7777E-06	-3.6995E-05	-2.3867E-05
Pile N.	10	1	3	1	1	1

* PILE TOP REACTIONS *

PILE GROUP	AXIAL, KN	LAT. y, KN	LAT. z, KN	MOM x, KN- M	MOM y, KN- M	MOM z, KN- M
1	2556.7	41.747	-106.13	-0.7376	234.07	77.928
2	2352.8	35.762	-88.157	-0.7376	198.00	67.431
3	2148.9	39.394	-92.681	-0.7376	202.33	73.828
4	2872.7	35.766	-101.21	-0.7376	225.39	63.501
5	2668.8	30.208	-83.175	-0.7376	188.88	53.673
6	2464.9	33.405	-87.588	-0.7376	193.24	59.357
7	3188.7	32.897	-104.26	-0.7376	230.85	54.435
8	2984.9	27.985	-86.512	-0.7376	195.07	45.889
9	2781.0	30.892	-90.808	-0.7376	199.06	50.968
10	3504.8	36.981	-130.14	-0.7376	275.10	56.663
11	3300.9	34.112	-116.41	-0.7376	247.69	52.041
12	3097.0	35.851	-116.93	-0.7376	244.13	54.836
MINIMUM	2148.9	27.985	-130.14	-0.7376	188.88	45.889
Pile N.	3	8	10	1	5	8
MAXIMUM	3504.8	41.747	-83.175	-0.7376	275.10	77.928
Pile N.	10	1	5	1	10	1

PILE GROUP STRESS, KN/ M**2

PILE GROUP	STRESS, KN/ M**2
1	2191.3
2	1962.7
3	1866.0
4	2332.3
5	2102.8
6	2005.0
7	2520.3
8	2293.9
9	2193.9
10	2831.0
11	2631.8
12	2507.7
MINIMUM	1866.0

APPALTATORE:

Consorzio

Soci



ITINERARIO NAPOLI – BARI

PROGETTAZIONE:

Mandataria

Mandanti



RADDOPPIO TRATTA APICE – ORSARA
I LOTTO FUNZIONALE APICE – HIRPINIA

PROGETTO ESECUTIVO

RELAZIONE DI CALCOLO FONDAZIONI SPALLA A

COMMESSA IF1N	LOTTO 01 E ZZ	CODIFICA RG	DOCUMENTO MD0000 001	REV. B	FOGLIO 48 di 109
------------------	------------------	----------------	-------------------------	-----------	---------------------

Pile N. 3
MAXIMUM 2831.0
Pile N. 10

* EFFECTS FOR Laterally LOADED PILE *

* MINIMUM VALUES AND LOCATIONS *

PILE	DISPL.		MOMENT		SHEAR		SOIL REACT		TOTAL STRESS KN/ M**2	FLEX. RIG.	
	y- DIR M	z- DIR M	z- DIR KN- M	y- DIR KN- M	y- DIR KN	z- DIR KN	y- DIR KN/ M	z- DIR KN/ M		z- DIR KN- M**2	y- DIR KN- M**2
1	-2.4984E-06	-4.2476E-04	-77.928	-104.02	-9.8682	-106.14	-3.6436	-24.859	1446.8	7.8279E+06	7.8279E+06
x (M)	10.260	0.0000	0.0000	5.6700	8.6400	0.0000	10.530	3.2400	27.000	0.0000	0.0000
2	-2.2947E-06	-4.1226E-04	-67.431	-92.563	-8.8193	-88.165	-2.8071	-19.937	1331.4	7.8279E+06	7.8279E+06
x (M)	10.800	0.0000	0.0000	5.9400	9.1800	0.0000	11.070	3.2400	27.000	0.0000	0.0000
3	-2.4106E-06	-3.9976E-04	-73.828	-94.758	-9.4551	-92.688	-3.2863	-21.550	1216.0	7.8279E+06	7.8279E+06
x (M)	10.530	0.0000	0.0000	5.6700	8.9100	0.0000	10.800	3.2400	27.000	0.0000	0.0000
4	-2.3232E-06	-4.2476E-04	-63.501	-101.08	-8.8915	-101.22	-3.1776	-23.417	1625.6	7.8279E+06	7.8279E+06
x (M)	10.260	0.0000	0.0000	5.6700	8.6400	0.0000	10.530	3.2400	27.000	0.0000	0.0000
5	-2.1430E-06	-4.1226E-04	-53.673	-89.471	-7.8914	-83.184	-2.4269	-18.521	1510.2	7.8279E+06	7.8279E+06
x (M)	10.800	0.0000	0.0000	5.9400	9.1800	0.0000	11.070	3.2400	27.000	0.0000	0.0000
6	-2.2422E-06	-3.9976E-04	-59.357	-91.581	-8.4701	-87.596	-2.8373	-20.076	1394.9	7.8279E+06	7.8279E+06
x (M)	10.530	0.0000	0.0000	5.6700	8.9100	0.0000	10.800	3.2400	27.000	0.0000	0.0000
7	-2.2888E-06	-4.2476E-04	-54.435	-102.95	-8.4593	-104.28	-3.2038	-24.317	1804.5	7.8279E+06	7.8279E+06
x (M)	10.260	0.0000	0.0000	5.6700	8.3700	0.0000	10.530	3.2400	27.000	0.0000	0.0000
8	-2.0987E-06	-4.1226E-04	-45.889	-91.591	-7.5785	-86.522	-2.4654	-19.475	1689.1	7.8279E+06	7.8279E+06
x (M)	10.530	0.0000	0.0000	5.9400	8.9100	0.0000	10.800	3.2400	27.000	0.0000	0.0000
9	-2.2037E-06	-3.9976E-04	-50.968	-93.637	-8.1052	-90.817	-2.8842	-21.013	1573.7	7.8279E+06	7.8279E+06
x (M)	10.260	0.0000	0.0000	5.6700	8.6400	0.0000	10.530	3.2400	27.000	0.0000	0.0000
10	-2.5904E-06	-4.2476E-04	-56.663	-117.53	-9.2967	-130.15	-4.4557	-32.229	1983.3	7.8279E+06	7.8279E+06
x (M)	9.4500	0.0000	0.0000	5.4000	7.8300	0.0000	10.260	2.9700	27.000	0.0000	0.0000
11	-2.4562E-06	-4.1226E-04	-52.041	-109.18	-8.7810	-116.42	-3.9889	-28.334	1867.9	7.8279E+06	7.8279E+06
x (M)	9.7200	0.0000	0.0000	5.4000	8.1000	0.0000	10.260	2.9700	27.000	0.0000	0.0000
12	-2.5317E-06	-3.9976E-04	-54.836	-108.76	-9.0917	-116.94	-4.2725	-28.918	1752.5	7.8279E+06	7.8279E+06
x (M)	9.4500	0.0000	0.0000	5.4000	7.8300	0.0000	10.260	2.9700	27.000	0.0000	0.0000
Min.	-2.5904E-06	-4.2476E-04	-77.928	-117.53	-9.8682	-130.15	-4.4557	-32.229	1216.0	7.8279E+06	7.8279E+06
Pile N.	10	1	1	10	1	10	10	10	3	1	1







* MAXIMUM VALUES AND LOCATIONS *

PILE	DISPL.		MOMENT		SHEAR		SOIL REACT		TOTAL STRESS KN/ M**2	FLEX. RIG.	
	y- DIR M	z- DIR M	z- DIR KN- M	y- DIR KN- M	y- DIR KN	z- DIR KN	y- DIR KN/ M	z- DIR KN/ M		z- DIR KN- M**2	y- DIR KN- M**2
1	1.9255E-04	5.0218E-06	47.580	234.07	41.751	22.074	10.326	7.5691	2191.3	7.8279E+06	7.8279E+06
x (M)	0.0000	10.530	5.4000	0.0000	0.0000	8.9100	2.9700	10.800	0.0000	0.0000	0.0000
2	1.9255E-04	4.5629E-06	43.740	198.00	35.765	19.087	8.5503	5.7640	1962.7	7.8279E+06	7.8279E+06
x (M)	0.0000	11.070	5.4000	0.0000	0.0000	9.4500	3.2400	11.340	0.0000	0.0000	0.0000
3	1.9255E-04	4.6379E-06	46.109	202.33	39.396	19.852	9.6100	6.5017	1866.0	7.8279E+06	7.8279E+06
x (M)	0.0000	10.800	5.4000	0.0000	0.0000	9.1800	2.9700	11.070	0.0000	0.0000	0.0000
4	1.8005E-04	4.9050E-06	43.513	225.39	35.769	21.294	8.8895	6.9691	2332.3	7.8279E+06	7.8279E+06
x (M)	0.0000	10.800	5.4000	0.0000	0.0000	9.1800	2.9700	11.070	0.0000	0.0000	0.0000
5	1.8005E-04	4.4871E-06	39.865	188.88	30.210	18.212	7.2562	5.2849	2102.8	7.8279E+06	7.8279E+06
x (M)	0.0000	11.340	5.4000	0.0000	0.0000	9.7200	3.2400	11.610	0.0000	0.0000	0.0000
6	1.8005E-04	4.5080E-06	42.003	193.24	33.408	18.994	8.1783	5.9080	2005.0	7.8279E+06	7.8279E+06
x (M)	0.0000	11.070	5.4000	0.0000	0.0000	9.1800	2.9700	11.340	0.0000	0.0000	0.0000
7	1.6755E-04	4.9835E-06	41.521	230.85	32.900	21.788	8.3973	7.3240	2520.3	7.8279E+06	7.8279E+06
x (M)	0.0000	10.800	5.1300	0.0000	0.0000	9.1800	2.9700	10.800	0.0000	0.0000	0.0000
8	1.6755E-04	4.5256E-06	38.260	195.07	27.987	18.818	6.9212	5.6000	2293.9	7.8279E+06	7.8279E+06
x (M)	0.0000	11.340	5.4000	0.0000	0.0000	9.4500	2.9700	11.340	0.0000	0.0000	0.0000
9	1.6755E-04	4.5897E-06	40.197	199.06	30.894	19.559	7.7872	6.2918	2193.9	7.8279E+06	7.8279E+06
x (M)	0.0000	10.800	5.1300	0.0000	0.0000	9.1800	2.9700	11.070	0.0000	0.0000	0.0000
10	1.5505E-04	5.9078E-06	43.871	275.10	36.984	25.864	10.122	11.322	2831.0	7.8279E+06	7.8279E+06
x (M)	0.0000	9.9900	4.8600	0.0000	0.0000	8.3700	2.7000	10.260	0.0000	0.0000	0.0000
11	1.5505E-04	5.4128E-06	42.149	247.69	34.115	23.699	9.1833	9.4761	2631.8	7.8279E+06	7.8279E+06
x (M)	0.0000	10.260	4.8600	0.0000	0.0000	8.6400	2.7000	10.530	0.0000	0.0000	0.0000
12	1.5505E-04	5.4848E-06	43.195	244.13	35.854	23.736	9.7482	10.138	2507.7	7.8279E+06	7.8279E+06
x (M)	0.0000	9.9900	4.8600	0.0000	0.0000	8.3700	2.7000	10.260	0.0000	0.0000	0.0000
Max.	1.9255E-04	5.9078E-06	47.580	275.10	41.751	25.864	10.326	11.322	2831.0	7.8279E+06	7.8279E+06
Pile N.	1	10	1	10	1	10	1	10	10	1	1

LOAD CASE : 3
CASE NAME : Load Case
LOAD TYPE : Special, Sp

REDUCTION FACTORS FOR CLOSELY-SPACED PILE GROUPS, COMBINED Y AND Z DIRECTIONS
ESTIMATED USING MOVEMENT IN THE DIRECTION OF PILE CAP DISPLACEMENTS

GROUP NO	P-FACTOR	Y-FACTOR
1	0.7656	1.0000
2	0.5475	1.0000
3	0.5845	1.0000

APPALTATORE: Consorzio Soci   	ITINERARIO NAPOLI – BARI RADDOPPIO TRATTA APICE – ORSARA I LOTTO FUNZIONALE APICE – HIRPINIA
PROGETTAZIONE: Mandataria Mandanti   	
PROGETTO ESECUTIVO RELAZIONE DI CALCOLO FONDAZIONI SPALLA A	COMMESSA IF1N LOTTO 01 E ZZ CODIFICA RG DOCUMENTO MD0000 001 REV. B FOGLIO 49 di 109

4	0.7122	1.0000
5	0.4823	1.0000
6	0.5157	1.0000
7	0.7231	1.0000
8	0.4955	1.0000
9	0.5306	1.0000
10	0.8661	1.0000
11	0.6790	1.0000
12	0.7110	1.0000

* TABLE L * COMPUTATION ON PILE CAP

* EQUIVALENT CONCENTRATED LOAD AT ORIGIN *

VERT. LOAD, KN 39701.0	HOR. LOAD Y, KN 1383.00	HOR. LOAD Z, KN -1177.00
MOMENT X, KN- M -257.000	MOMENT Y, KN- M -25513.5	MOMENT Z, KN- M -17007.5

* DISPLACEMENT OF GROUPED PILE FOUNDATION AT ORIGIN *

VERTICAL, M 1.69267E-03	HORIZONTAL Y, M 5.28121E-04	HORIZONTAL Z, M -4.32395E-04
ANGLE ROT. X, RAD -1.40711E-06	ANGLE ROT. Y, RAD -4.83044E-05	ANGLE ROT. Z, RAD -6.38339E-05

THE GLOBAL STRUCTURAL COORDINATE SYSTEM

* PILE TOP DISPLACEMENTS *

PILE GROUP	DISP. X, M	DISP. Y, M	DISP. Z, M	ROT. X, RAD	ROT. Y, RAD	ROT. Z, RAD
*****	*****	*****	*****	*****	*****	*****
1	1.6539E-03	5.3762E-04	-4.3873E-04	-1.4071E-06	-4.8304E-05	-6.3834E-05
2	1.3666E-03	5.3762E-04	-4.3240E-04	-1.4071E-06	-4.8304E-05	-6.3834E-05
3	1.0794E-03	5.3762E-04	-4.2606E-04	-1.4071E-06	-4.8304E-05	-6.3834E-05
4	1.8712E-03	5.3129E-04	-4.3873E-04	-1.4071E-06	-4.8304E-05	-6.3834E-05
5	1.5840E-03	5.3129E-04	-4.3240E-04	-1.4071E-06	-4.8304E-05	-6.3834E-05
6	1.2967E-03	5.3129E-04	-4.2606E-04	-1.4071E-06	-4.8304E-05	-6.3834E-05
7	2.0886E-03	5.2496E-04	-4.3873E-04	-1.4071E-06	-4.8304E-05	-6.3834E-05
8	1.8013E-03	5.2496E-04	-4.3240E-04	-1.4071E-06	-4.8304E-05	-6.3834E-05
9	1.5141E-03	5.2496E-04	-4.2606E-04	-1.4071E-06	-4.8304E-05	-6.3834E-05
10	2.3060E-03	5.1862E-04	-4.3873E-04	-1.4071E-06	-4.8304E-05	-6.3834E-05
11	2.0187E-03	5.1862E-04	-4.3240E-04	-1.4071E-06	-4.8304E-05	-6.3834E-05
12	1.7315E-03	5.1862E-04	-4.2606E-04	-1.4071E-06	-4.8304E-05	-6.3834E-05
MINIMUM	1.0794E-03	5.1862E-04	-4.3873E-04	-1.4071E-06	-4.8304E-05	-6.3834E-05
Pile N.	3	10	1	1	1	1
MAXIMUM	2.3060E-03	5.3762E-04	-4.2606E-04	-1.4071E-06	-4.8304E-05	-6.3834E-05
Pile N.	10	1	3	1	1	1

* PILE TOP REACTIONS *

PILE GROUP	FOR. X, KN	FOR. Y, KN	FOR. Z, KN	MOM X, KN- M	MOM Y, KN- M	MOM Z, KN- M
*****	*****	*****	*****	*****	*****	*****
1	3234.8	135.48	-114.22	-0.3736	225.03	256.63
2	2689.4	107.36	-88.912	-0.3736	179.21	208.27
3	2144.1	112.43	-91.080	-0.3736	180.97	217.10
4	3647.4	126.63	-108.70	-0.3736	215.78	239.63
5	3102.1	96.430	-81.411	-0.3736	165.77	186.83
6	2556.8	101.13	-83.484	-0.3736	167.54	195.20
7	4060.1	125.69	-109.81	-0.3736	217.71	235.92
8	3514.7	96.475	-82.936	-0.3736	168.59	185.07
9	2969.4	101.29	-85.133	-0.3736	170.55	193.59
10	4472.7	139.87	-124.11	-0.3736	241.56	257.13
11	3927.4	118.16	-103.04	-0.3736	204.02	220.98
12	3382.1	122.06	-104.16	-0.3736	203.69	227.50
MINIMUM	2144.1	96.430	-124.11	-0.3736	165.77	185.07
Pile N.	3	5	10	1	5	8
MAXIMUM	4472.7	139.87	-81.411	-0.3736	241.56	257.13
Pile N.	10	10	5	1	10	10

THE PILE COORDINATE SYSTEM (LOCAL AXES)

* PILE TOP DISPLACEMENTS *

APPALTATORE:

Consorzio

Soci



ITINERARIO NAPOLI – BARI

PROGETTAZIONE:

Mandatario

Mandanti



RADDOPPIO TRATTA APICE – ORSARA
I LOTTO FUNZIONALE APICE – HIRPINIA

PROGETTO ESECUTIVO

RELAZIONE DI CALCOLO FONDAZIONI SPALLA A

COMMESSA IF1N	LOTTO 01 E ZZ	CODIFICA RG	DOCUMENTO MD0000 001	REV. B	FOGLIO 50 di 109
------------------	------------------	----------------	-------------------------	-----------	---------------------

PILE GROUP *****	DISP. x, M *****	DISP. y, M *****	DISP. z, M *****	ROT. x,RAD *****	ROT. y,RAD *****	ROT. z,RAD *****
1	1.6539E-03	5.3762E-04	-4.3873E-04	-1.4071E-06	-4.8304E-05	-6.3834E-05
2	1.3666E-03	5.3762E-04	-4.3240E-04	-1.4071E-06	-4.8304E-05	-6.3834E-05
3	1.0794E-03	5.3762E-04	-4.2606E-04	-1.4071E-06	-4.8304E-05	-6.3834E-05
4	1.8712E-03	5.3129E-04	-4.3873E-04	-1.4071E-06	-4.8304E-05	-6.3834E-05
5	1.5840E-03	5.3129E-04	-4.3240E-04	-1.4071E-06	-4.8304E-05	-6.3834E-05
6	1.2967E-03	5.3129E-04	-4.2606E-04	-1.4071E-06	-4.8304E-05	-6.3834E-05
7	2.0886E-03	5.2496E-04	-4.3873E-04	-1.4071E-06	-4.8304E-05	-6.3834E-05
8	1.8013E-03	5.2496E-04	-4.3240E-04	-1.4071E-06	-4.8304E-05	-6.3834E-05
9	1.5141E-03	5.2496E-04	-4.2606E-04	-1.4071E-06	-4.8304E-05	-6.3834E-05
10	2.3060E-03	5.1862E-04	-4.3873E-04	-1.4071E-06	-4.8304E-05	-6.3834E-05
11	2.0187E-03	5.1862E-04	-4.3240E-04	-1.4071E-06	-4.8304E-05	-6.3834E-05
12	1.7315E-03	5.1862E-04	-4.2606E-04	-1.4071E-06	-4.8304E-05	-6.3834E-05
MINIMUM Pile N.	1.0794E-03 3	5.1862E-04 10	-4.3873E-04 1	-1.4071E-06 1	-4.8304E-05 1	-6.3834E-05 1
MAXIMUM Pile N.	2.3060E-03 10	5.3762E-04 1	-4.2606E-04 3	-1.4071E-06 1	-4.8304E-05 1	-6.3834E-05 1

* PILE TOP REACTIONS *

PILE GROUP *****	AXIAL, KN *****	LAT. y, KN *****	LAT. z, KN *****	MOM x, KN- M *****	MOM y, KN- M *****	MOM z, KN- M *****
1	3234.8	135.48	-114.22	-0.3736	225.03	256.63
2	2689.4	107.36	-88.912	-0.3736	179.21	208.27
3	2144.1	112.43	-91.080	-0.3736	180.97	217.10
4	3647.4	126.63	-108.70	-0.3736	215.78	239.63
5	3102.1	96.430	-81.411	-0.3736	165.77	186.83
6	2556.8	101.13	-83.484	-0.3736	167.54	195.20
7	4060.1	125.69	-109.81	-0.3736	217.71	235.92
8	3514.7	96.475	-82.936	-0.3736	168.59	185.07
9	2969.4	101.29	-85.133	-0.3736	170.55	193.59
10	4472.7	139.87	-124.11	-0.3736	241.56	257.13
11	3927.4	118.16	-103.04	-0.3736	204.02	220.98
12	3382.1	122.06	-104.16	-0.3736	203.69	227.50
MINIMUM Pile N.	2144.1 3	96.430 5	-124.11 10	-0.3736 1	165.77 5	185.07 8
MAXIMUM Pile N.	4472.7 10	139.87 10	-81.411 5	-0.3736 1	241.56 10	257.13 10

PILE GROUP STRESS, KN/ M**2

PILE GROUP *****	STRESS, KN/ M**2 *****
1	2860.6
2	2351.1
3	2066.3
4	3037.2
5	2509.3
6	2223.2
7	3266.4
8	2744.5
9	2459.0
10	3595.8
11	3130.2
12	2835.5
MINIMUM Pile N.	2066.3 3
MAXIMUM Pile N.	3595.8 10

* EFFECTS FOR Laterally LOADED PILE *

* MINIMUM VALUES AND LOCATIONS *

PILE	DISPL. y-DIR M	DISPL. z-DIR M	MOMENT z-DIR KN- M	MOMENT y-DIR KN- M	SHEAR y-DIR KN	SHEAR z-DIR KN	SOIL REACT y-DIR KN/ M	SOIL REACT z-DIR KN/ M	TOTAL STRESS KN/ M**2	FLEX. RIG. z-DIR KN- M**2	FLEX. RIG. y-DIR KN- M**2
1	-7.5436E-06	-4.3873E-04	-256.63	-115.88	-30.338	-114.23	-12.812	-28.518	1830.5	7.8279E+06	7.8279E+06
x(M)	9.9900	0.0000	0.0000	5.4000	8.3700	0.0000	10.260	2.9700	27.000	0.0000	0.0000
2	-6.4576E-06	-4.3240E-04	-208.27	-100.36	-25.574	-88.920	-8.3999	-21.045	1521.9	7.8279E+06	7.8279E+06
x(M)	10.800	0.0000	0.0000	5.6700	8.9100	0.0000	10.800	3.2400	27.000	0.0000	0.0000
3	-6.6303E-06	-4.2606E-04	-217.10	-101.43	-26.438	-91.086	-9.0903	-21.827	1213.3	7.8279E+06	7.8279E+06
x(M)	10.530	0.0000	0.0000	5.4000	8.9100	0.0000	10.800	3.2400	27.000	0.0000	0.0000
4	-7.1892E-06	-4.3873E-04	-239.63	-112.75	-28.881	-108.72	-11.548	-26.810	2064.0	7.8279E+06	7.8279E+06
x(M)	9.9900	0.0000	0.0000	5.4000	8.3700	0.0000	10.260	2.9700	27.000	0.0000	0.0000
5	-6.1560E-06	-4.3240E-04	-186.83	-95.610	-23.685	-81.420	-7.2307	-18.893	1755.4	7.8279E+06	7.8279E+06
x(M)	11.070	0.0000	0.0000	5.6700	9.1800	0.0000	11.070	3.2400	27.000	0.0000	0.0000
6	-6.2907E-06	-4.2606E-04	-195.20	-96.729	-24.500	-83.491	-7.7958	-19.630	1446.8	7.8279E+06	7.8279E+06
x(M)	10.800	0.0000	0.0000	5.6700	9.1800	0.0000	11.070	3.2400	27.000	0.0000	0.0000
7	-7.2103E-06	-4.3873E-04	-235.92	-113.42	-28.770	-109.83	-11.692	-27.159	2297.5	7.8279E+06	7.8279E+06
x(M)	9.9900	0.0000	0.0000	5.4000	8.3700	0.0000	10.260	2.9700	27.000	0.0000	0.0000
8	-6.1656E-06	-4.3240E-04	-185.07	-96.635	-23.739	-82.946	-7.3970	-19.334	1988.9	7.8279E+06	7.8279E+06
x(M)	10.800	0.0000	0.0000	5.6700	9.1800	0.0000	11.070	3.2400	27.000	0.0000	0.0000
9	-6.2982E-06	-4.2606E-04	-193.59	-97.794	-24.563	-85.142	-7.9650	-20.111	1680.4	7.8279E+06	7.8279E+06
x(M)	10.800	0.0000	0.0000	5.6700	8.9100	0.0000	11.070	3.2400	27.000	0.0000	0.0000

APPALTATORE: Consorzio Soci   		ITINERARIO NAPOLI – BARI					
PROGETTAZIONE: Mandataria Mandanti   		RADDOPPIO TRATTA APICE – ORSARA I LOTTO FUNZIONALE APICE – HIRPINIA					
PROGETTO ESECUTIVO RELAZIONE DI CALCOLO FONDAZIONI SPALLA A		COMMESSA IF1N	LOTTO 01 E ZZ	CODIFICA RG	DOCUMENTO MD0000 001	REV. B	FOGLIO 51 di 109

10	-7.8811E-06	-4.3873E-04	-257.13	-121.56	-31.154	-124.13	-14.422	-31.654	2531.0	7.8279E+06	7.8279E+06
x(M)	9.7200	0.0000	0.0000	5.1300	8.1000	0.0000	10.260	2.9700	27.000	0.0000	0.0000
11	-6.9379E-06	-4.3240E-04	-220.98	-109.16	-27.515	-103.06	-10.653	-25.270	2222.4	7.8279E+06	7.8279E+06
x(M)	10.260	0.0000	0.0000	5.4000	8.6400	0.0000	10.530	2.9700	27.000	0.0000	0.0000
12	-7.0796E-06	-4.2606E-04	-227.50	-109.51	-28.153	-104.17	-11.321	-25.807	1913.9	7.8279E+06	7.8279E+06
x(M)	9.9900	0.0000	0.0000	5.4000	8.3700	0.0000	10.260	2.9700	27.000	0.0000	0.0000
Min.	-7.8811E-06	-4.3873E-04	-257.13	-121.56	-31.154	-124.13	-14.422	-31.654	1213.3	7.8279E+06	7.8279E+06
Pile N.	10	1	10	10	10	10	10	10	3	1	1

* MAXIMUM VALUES AND LOCATIONS *

PILE	DISPL. y-DIR M	DISPL. z-DIR M	MOMENT KN- M	MOMENT y-DIR KN- M	SHEAR y-DIR KN	SHEAR z-DIR KN	SOIL REACT y-DIR KN/ M	SOIL REACT z-DIR KN/ M	TOTAL STRESS KN/ M**2	FLEX. RIG. z-DIR KN- M**2	FLEX. RIG. y-DIR KN- M**2
*****	*****	*****	*****	*****	*****	*****	*****	*****	*****	*****	*****
1	5.3762E-04	6.0059E-06	142.29	225.03	135.49	24.819	34.264	10.289	2860.6	7.8279E+06	7.8279E+06
x(M)	0.0000	9.9900	5.1300	0.0000	0.0000	8.3700	2.9700	10.260	0.0000	0.0000	0.0000
2	5.3762E-04	5.1115E-06	125.12	179.21	107.37	20.601	25.705	6.6904	2351.1	7.8279E+06	7.8279E+06
x(M)	0.0000	10.800	5.4000	0.0000	0.0000	9.1800	3.2400	11.070	0.0000	0.0000	0.0000
3	5.3762E-04	5.1729E-06	128.37	180.97	112.43	20.984	27.171	7.1347	2066.3	7.8279E+06	7.8279E+06
x(M)	0.0000	10.530	5.4000	0.0000	0.0000	8.9100	3.2400	10.800	0.0000	0.0000	0.0000
4	5.3129E-04	5.7916E-06	136.86	215.78	126.64	23.938	31.725	9.3400	3037.2	7.8279E+06	7.8279E+06
x(M)	0.0000	10.260	5.4000	0.0000	0.0000	8.6400	2.9700	10.530	0.0000	0.0000	0.0000
5	5.3129E-04	4.9231E-06	117.97	165.77	96.440	19.290	22.718	5.8284	2509.3	7.8279E+06	7.8279E+06
x(M)	0.0000	11.070	5.6700	0.0000	0.0000	9.4500	3.2400	11.340	0.0000	0.0000	0.0000
6	5.3129E-04	4.9515E-06	120.93	167.54	101.14	19.682	24.058	6.1836	2223.2	7.8279E+06	7.8279E+06
x(M)	0.0000	10.800	5.6700	0.0000	0.0000	9.1800	3.2400	11.070	0.0000	0.0000	0.0000
7	5.2496E-04	5.8336E-06	136.07	217.71	125.71	24.124	31.648	9.5210	3266.4	7.8279E+06	7.8279E+06
x(M)	0.0000	10.260	5.1300	0.0000	0.0000	8.6400	2.9700	10.260	0.0000	0.0000	0.0000
8	5.2496E-04	4.9557E-06	117.84	168.59	96.486	19.584	22.886	5.9905	2744.5	7.8279E+06	7.8279E+06
x(M)	0.0000	11.070	5.6700	0.0000	0.0000	9.1800	3.2400	11.340	0.0000	0.0000	0.0000
9	5.2496E-04	5.0074E-06	120.94	170.55	101.30	19.978	24.263	6.3886	2459.0	7.8279E+06	7.8279E+06
x(M)	0.0000	10.800	5.4000	0.0000	0.0000	9.1800	3.2400	11.070	0.0000	0.0000	0.0000
10	5.1862E-04	6.4270E-06	144.27	241.56	139.89	26.431	36.329	12.023	3595.8	7.8279E+06	7.8279E+06
x(M)	0.0000	9.7200	5.1300	0.0000	0.0000	8.1000	2.9700	10.260	0.0000	0.0000	0.0000
11	5.1862E-04	5.6055E-06	131.38	204.02	118.17	23.027	29.521	8.7064	3130.2	7.8279E+06	7.8279E+06
x(M)	0.0000	10.260	5.4000	0.0000	0.0000	8.6400	2.9700	10.530	0.0000	0.0000	0.0000
12	5.1862E-04	5.6626E-06	133.64	203.69	122.07	23.191	30.716	9.0935	2835.5	7.8279E+06	7.8279E+06
x(M)	0.0000	10.260	5.1300	0.0000	0.0000	8.6400	2.9700	10.530	0.0000	0.0000	0.0000
Max.	5.3762E-04	6.4270E-06	144.27	241.56	139.89	26.431	36.329	12.023	3595.8	7.8279E+06	7.8279E+06
Pile N.	1	10	10	10	10	10	10	10	10	1	1

LOAD CASE : 4
CASE NAME : Load Case
LOAD TYPE : Special, Sp

REDUCTION FACTORS FOR CLOSELY-SPACED PILE GROUPS, COMBINED Y AND Z DIRECTIONS
ESTIMATED USING MOVEMENT IN THE DIRECTION OF PILE CAP DISPLACEMENTS

GROUP NO	P-FACTOR	Y-FACTOR
1	0.8514	1.0000
2	0.5743	1.0000
3	0.5845	1.0000
4	0.7917	1.0000
5	0.4932	1.0000
6	0.4987	1.0000
7	0.7932	1.0000
8	0.4952	1.0000
9	0.5011	1.0000
10	0.8661	1.0000
11	0.5955	1.0000
12	0.6057	1.0000

* TABLE L * COMPUTATION ON PILE CAP

* EQUIVALENT CONCENTRATED LOAD AT ORIGIN *

VERT. LOAD, KN	HOR. LOAD Y, KN	HOR. LOAD Z, KN
41386.0	3552.00	-1006.00
MOMENT X, KN- M	MOMENT Y, KN- M	MOMENT Z, KN- M
-485.000	-16446.0	-42427.0

* DISPLACEMENT OF GROUPED PILE FOUNDATION AT ORIGIN *

VERTICAL, M	HORIZONTAL Y, M	HORIZONTAL Z, M
1.76663E-03	1.34338E-03	-3.44324E-04

APPALTATORE:

Consorzio

Soci



ITINERARIO NAPOLI – BARI

RADDOPPIO TRATTA APICE – ORSARA
I LOTTO FUNZIONALE APICE – HIRPINIA

PROGETTAZIONE:

Mandatario

Mandanti



PROGETTO ESECUTIVO

RELAZIONE DI CALCOLO FONDAZIONI SPALLA A

COMMESSA
IF1N

LOTTO
01 E ZZ

CODIFICA
RG

DOCUMENTO
MD0000 001

REV.
B

FOGLIO
52 di 109

ANGLE ROT. X,RAD ANGLE ROT. Y,RAD ANGLE ROT. Z,RAD
-1.12257E-06 -3.22686E-05 -1.60058E-04

THE GLOBAL STRUCTURAL COORDINATE SYSTEM

* PILE TOP DISPLACEMENTS *

PILE GROUP	DISP. X, M	DISP. Y, M	DISP. Z, M	ROT. X,RAD	ROT. Y,RAD	ROT. Z,RAD
*****	*****	*****	*****	*****	*****	*****
1	2.2691E-03	1.3510E-03	-3.4938E-04	-1.1226E-06	-3.2269E-05	-1.6006E-04
2	1.5488E-03	1.3510E-03	-3.4432E-04	-1.1226E-06	-3.2269E-05	-1.6006E-04
3	8.2856E-04	1.3510E-03	-3.3927E-04	-1.1226E-06	-3.2269E-05	-1.6006E-04
4	2.4143E-03	1.3459E-03	-3.4938E-04	-1.1226E-06	-3.2269E-05	-1.6006E-04
5	1.6940E-03	1.3459E-03	-3.4432E-04	-1.1226E-06	-3.2269E-05	-1.6006E-04
6	9.7377E-04	1.3459E-03	-3.3927E-04	-1.1226E-06	-3.2269E-05	-1.6006E-04
7	2.5595E-03	1.3409E-03	-3.4938E-04	-1.1226E-06	-3.2269E-05	-1.6006E-04
8	1.8392E-03	1.3409E-03	-3.4432E-04	-1.1226E-06	-3.2269E-05	-1.6006E-04
9	1.1190E-03	1.3409E-03	-3.3927E-04	-1.1226E-06	-3.2269E-05	-1.6006E-04
10	2.7047E-03	1.3358E-03	-3.4938E-04	-1.1226E-06	-3.2269E-05	-1.6006E-04
11	1.9845E-03	1.3358E-03	-3.4432E-04	-1.1226E-06	-3.2269E-05	-1.6006E-04
12	1.2642E-03	1.3358E-03	-3.3927E-04	-1.1226E-06	-3.2269E-05	-1.6006E-04
MINIMUM	8.2856E-04	1.3358E-03	-3.4938E-04	-1.1226E-06	-3.2269E-05	-1.6006E-04
Pile N.	3	10	1	1	1	1
MAXIMUM	2.7047E-03	1.3510E-03	-3.3927E-04	-1.1226E-06	-3.2269E-05	-1.6006E-04
Pile N.	10	1	3	1	1	1

* PILE TOP REACTIONS *

PILE GROUP	FOR. X, KN	FOR. Y, KN	FOR. Z, KN	MOM X, KN- M	MOM Y, KN- M	MOM Z, KN- M
*****	*****	*****	*****	*****	*****	*****
1	4402.7	366.38	-103.95	-0.2981	216.58	689.03
2	3035.3	279.21	-78.508	-0.2981	171.06	540.96
3	1668.0	282.89	-77.922	-0.2981	168.30	546.84
4	4678.3	346.58	-99.057	-0.2981	208.44	654.73
5	3311.0	249.46	-70.855	-0.2981	157.25	486.56
6	1943.7	251.65	-70.012	-0.2981	154.08	489.92
7	4954.0	345.10	-99.169	-0.2981	208.65	650.57
8	3586.7	248.71	-71.038	-0.2981	157.62	483.79
9	2219.3	251.02	-70.228	-0.2981	154.50	487.37
10	5229.7	364.56	-105.09	-0.2981	218.55	680.77
11	3862.3	281.43	-80.400	-0.2981	174.50	540.32
12	2495.0	285.01	-79.767	-0.2981	171.65	545.98
MINIMUM	1668.0	248.71	-105.09	-0.2981	154.08	483.79
Pile N.	3	8	10	1	6	8
MAXIMUM	5229.7	366.38	-70.012	-0.2981	218.55	689.03
Pile N.	10	1	6	1	10	1

THE PILE COORDINATE SYSTEM (LOCAL AXES)

* PILE TOP DISPLACEMENTS *

PILE GROUP	DISP. x, M	DISP. y, M	DISP. z, M	ROT. x,RAD	ROT. y,RAD	ROT. z,RAD
*****	*****	*****	*****	*****	*****	*****
1	2.2691E-03	1.3510E-03	-3.4938E-04	-1.1226E-06	-3.2269E-05	-1.6006E-04
2	1.5488E-03	1.3510E-03	-3.4432E-04	-1.1226E-06	-3.2269E-05	-1.6006E-04
3	8.2856E-04	1.3510E-03	-3.3927E-04	-1.1226E-06	-3.2269E-05	-1.6006E-04
4	2.4143E-03	1.3459E-03	-3.4938E-04	-1.1226E-06	-3.2269E-05	-1.6006E-04
5	1.6940E-03	1.3459E-03	-3.4432E-04	-1.1226E-06	-3.2269E-05	-1.6006E-04
6	9.7377E-04	1.3459E-03	-3.3927E-04	-1.1226E-06	-3.2269E-05	-1.6006E-04
7	2.5595E-03	1.3409E-03	-3.4938E-04	-1.1226E-06	-3.2269E-05	-1.6006E-04
8	1.8392E-03	1.3409E-03	-3.4432E-04	-1.1226E-06	-3.2269E-05	-1.6006E-04
9	1.1190E-03	1.3409E-03	-3.3927E-04	-1.1226E-06	-3.2269E-05	-1.6006E-04
10	2.7047E-03	1.3358E-03	-3.4938E-04	-1.1226E-06	-3.2269E-05	-1.6006E-04
11	1.9845E-03	1.3358E-03	-3.4432E-04	-1.1226E-06	-3.2269E-05	-1.6006E-04
12	1.2642E-03	1.3358E-03	-3.3927E-04	-1.1226E-06	-3.2269E-05	-1.6006E-04
MINIMUM	8.2856E-04	1.3358E-03	-3.4938E-04	-1.1226E-06	-3.2269E-05	-1.6006E-04
Pile N.	3	10	1	1	1	1
MAXIMUM	2.7047E-03	1.3510E-03	-3.3927E-04	-1.1226E-06	-3.2269E-05	-1.6006E-04
Pile N.	10	1	3	1	1	1

* PILE TOP REACTIONS *

PILE GROUP	AXIAL, KN	LAT. y, KN	LAT. z, KN	MOM x, KN- M	MOM y, KN- M	MOM z, KN- M
*****	*****	*****	*****	*****	*****	*****
1	4402.7	366.38	-103.95	-0.2981	216.58	689.03
2	3035.3	279.21	-78.508	-0.2981	171.06	540.96
3	1668.0	282.89	-77.922	-0.2981	168.30	546.84
4	4678.3	346.58	-99.057	-0.2981	208.44	654.73
5	3311.0	249.46	-70.855	-0.2981	157.25	486.56
6	1943.7	251.65	-70.012	-0.2981	154.08	489.92

APPALTATORE:

Consorzio

Soci



ITINERARIO NAPOLI – BARI

PROGETTAZIONE:

Mandataria

Mandanti



RADDOPPIO TRATTA APICE – ORSARA
I LOTTO FUNZIONALE APICE – HIRPINIA

PROGETTO ESECUTIVO

RELAZIONE DI CALCOLO FONDAZIONI SPALLA A

COMMESSA

LOTTO

CODIFICA

DOCUMENTO

REV.

FOGLIO

IF1N

01 E ZZ

RG

MD0000 001

B

53 di 109

7	4954.0	345.10	-99.169	-0.2981	208.65	650.57
8	3586.7	248.71	-71.038	-0.2981	157.62	483.79
9	2219.3	251.02	-70.228	-0.2981	154.50	487.37
10	5229.7	364.56	-105.09	-0.2981	218.55	680.77
11	3862.3	281.43	-80.400	-0.2981	174.50	540.32
12	2495.0	285.01	-79.767	-0.2981	171.65	545.98
MINIMUM	1668.0	248.71	-105.09	-0.2981	154.08	483.79
Pile N.	3	8	10	1	6	8
MAXIMUM	5229.7	366.38	-70.012	-0.2981	218.55	689.03
Pile N.	10	1	6	1	10	1

PILE GROUP STRESS, KN/ M**2

1	4671.2
2	3430.0
3	2670.7
4	4721.1
5	3416.9
6	2649.9
7	4865.4
8	3565.3
9	2798.9
10	5117.3
11	3899.3
12	3139.2

MINIMUM	2649.9
Pile N.	6
MAXIMUM	5117.3
Pile N.	10

* EFFECTS FOR LATERALLY LOADED PILE *

* MINIMUM VALUES AND LOCATIONS *

PILE	DISPL. y-DIR M	DISPL. z-DIR M	MOMENT z-DIR KN- M	MOMENT y-DIR KN- M	SHEAR y-DIR KN	SHEAR z-DIR KN	SOIL REACT y-DIR KN/ M	SOIL REACT z-DIR KN/ M	TOTAL STRESS KN/ M**2	FLEX. RIG. z-DIR KN- M**2	FLEX. RIG. y-DIR KN- M**2
*****	*****	*****	*****	*****	*****	*****	*****	*****	*****	*****	*****
1	-2.0063E-05	-3.4938E-04	-689.03	-96.037	-80.511	-103.97	-36.654	-25.837	2491.4	7.8279E+06	7.8279E+06
x(M)	9.7200	0.0000	0.0000	5.4000	8.1000	0.0000	10.260	2.9700	27.000	0.0000	0.0000
2	-1.6548E-05	-3.4432E-04	-540.96	-81.082	-65.905	-78.517	-22.389	-18.237	1717.7	7.8279E+06	7.8279E+06
x(M)	10.530	0.0000	0.0000	5.6700	8.9100	0.0000	10.800	3.2400	27.000	0.0000	0.0000
3	-1.6634E-05	-3.3927E-04	-546.84	-80.445	-66.412	-77.927	-22.816	-18.178	943.90	7.8279E+06	7.8279E+06
x(M)	10.530	0.0000	0.0000	5.6700	8.9100	0.0000	10.800	3.2400	27.000	0.0000	0.0000
4	-1.9251E-05	-3.4938E-04	-654.73	-93.351	-77.311	-99.074	-33.529	-24.299	2647.4	7.8279E+06	7.8279E+06
x(M)	9.9900	0.0000	0.0000	5.4000	8.3700	0.0000	10.260	2.9700	27.000	0.0000	0.0000
5	-1.5642E-05	-3.4432E-04	-486.56	-76.360	-60.725	-70.864	-18.760	-16.032	1873.6	7.8279E+06	7.8279E+06
x(M)	10.800	0.0000	0.0000	5.9400	9.1800	0.0000	11.070	3.2400	27.000	0.0000	0.0000
6	-1.5670E-05	-3.3927E-04	-489.92	-75.537	-60.994	-70.017	-15.961	-15.895	1099.9	7.8279E+06	7.8279E+06
x(M)	10.800	0.0000	0.0000	5.9400	9.1800	0.0000	11.070	3.2400	27.000	0.0000	0.0000
7	-1.9226E-05	-3.4938E-04	-650.57	-93.428	-77.097	-99.187	-33.519	-24.337	2803.4	7.8279E+06	7.8279E+06
x(M)	9.9900	0.0000	0.0000	5.4000	8.3700	0.0000	10.260	2.9700	27.000	0.0000	0.0000
8	-1.5639E-05	-3.4432E-04	-483.79	-76.486	-60.638	-71.048	-18.802	-16.087	2029.6	7.8279E+06	7.8279E+06
x(M)	10.800	0.0000	0.0000	5.9400	9.1800	0.0000	11.070	3.2400	27.000	0.0000	0.0000
9	-1.5670E-05	-3.3927E-04	-487.37	-75.682	-60.927	-70.234	-19.017	-15.959	1255.9	7.8279E+06	7.8279E+06
x(M)	10.800	0.0000	0.0000	5.9400	9.1800	0.0000	11.070	3.2400	27.000	0.0000	0.0000
10	-2.0140E-05	-3.4938E-04	-680.77	-96.688	-80.351	-105.11	-37.044	-26.209	2959.4	7.8279E+06	7.8279E+06
x(M)	9.7200	0.0000	0.0000	5.4000	8.1000	0.0000	10.260	2.9700	27.000	0.0000	0.0000
11	-1.6698E-05	-3.4432E-04	-540.32	-82.281	-66.379	-80.412	-23.182	-18.798	2185.6	7.8279E+06	7.8279E+06
x(M)	10.530	0.0000	0.0000	5.6700	8.9100	0.0000	10.800	3.2400	27.000	0.0000	0.0000
12	-1.6764E-05	-3.3927E-04	-545.98	-81.600	-66.849	-79.774	-23.586	-18.727	1411.9	7.8279E+06	7.8279E+06
x(M)	10.530	0.0000	0.0000	5.6700	8.9100	0.0000	10.800	3.2400	27.000	0.0000	0.0000
Min.	-2.0140E-05	-3.4938E-04	-689.03	-96.688	-80.511	-105.11	-37.044	-26.209	943.90	7.8279E+06	7.8279E+06
Pile N.	10	1	1	10	1	10	10	10	3	1	1

* MAXIMUM VALUES AND LOCATIONS *

PILE	DISPL. y-DIR M	DISPL. z-DIR M	MOMENT z-DIR KN- M	MOMENT y-DIR KN- M	SHEAR y-DIR KN	SHEAR z-DIR KN	SOIL REACT y-DIR KN/ M	SOIL REACT z-DIR KN/ M	TOTAL STRESS KN/ M**2	FLEX. RIG. z-DIR KN- M**2	FLEX. RIG. y-DIR KN- M**2
*****	*****	*****	*****	*****	*****	*****	*****	*****	*****	*****	*****
1	1.3510E-03	4.8728E-06	372.81	216.58	366.43	21.047	94.271	9.1785	4671.2	7.8279E+06	7.8279E+06
x(M)	0.0000	9.9900	5.1300	0.0000	0.0000	8.3700	10.260	2.9700	0.0000	0.0000	0.0000
2	1.3510E-03	3.9839E-06	320.39	171.06	279.24	16.949	67.308	5.5046	3430.0	7.8279E+06	7.8279E+06
x(M)	0.0000	10.800	5.4000	0.0000	0.0000	9.1800	3.2400	11.070	0.0000	0.0000	0.0000
3	1.3510E-03	3.9521E-06	322.48	168.30	282.91	16.818	68.325	5.5274	2670.7	7.8279E+06	7.8279E+06
x(M)	0.0000	10.800	5.4000	0.0000	0.0000	9.1800	3.2400	11.070	0.0000	0.0000	0.0000
4	1.3459E-03	4.6616E-06	361.14	208.44	346.63	20.277	88.212	8.3270	4721.1	7.8279E+06	7.8279E+06
x(M)	0.0000	9.9900	5.1300	0.0000	0.0000	8.6400	10.260	2.9700	0.0000	0.0000	0.0000
5	1.3459E-03	3.8040E-06	301.21	157.25	249.49	15.648	58.844	4.6675	3416.9	7.8279E+06	7.8279E+06
x(M)	0.0000	11.070	5.6700	0.0000	0.0000	9.4500	3.2400	11.340	0.0000	0.0000	0.0000
6	1.3459E-03	3.7633E-06	302.34	154.08	251.66	15.481	4.6510	2649.9	7.8279E+06	7.8279E+06	7.8279E+06
x(M)	0.0000	11.070	5.6700	0.0000	0.0000	9.4500	3.2400	11.340	0.0000	0.0000	0.0000
7	1.3409E-03	4.6700E-06	360.15	208.65	345.15	20.300	87.931	8.3527	4865.4	7.8279E+06	7.8279E+06
x(M)	0.0000	9.9900	5.1300	0.0000	0.0000	8.6400	10.260	2.9700	0.0000	0.0000	0.0000

APPALTATORE:

Consorzio

Soci



ITINERARIO NAPOLI – BARI

PROGETTAZIONE:

Mandataria

Mandanti



RADDOPPIO TRATTA APICE – ORSARA
I LOTTO FUNZIONALE APICE – HIRPINIA

PROGETTO ESECUTIVO

RELAZIONE DI CALCOLO FONDAZIONI SPALLA A

COMMESSA LOTTO CODIFICA DOCUMENTO REV. FOGLIO
IF1N 01 E ZZ RG MD0000 001 B 54 di 109

	8	1.3409E-03	3.8111E-06	300.63	157.62	248.74	15.687	58.758	4.6899	3565.3	7.8279E+06	7.8279E+06
x(M)		0.0000	11.070	5.6700	0.0000	0.0000	9.4500	3.2400	11.340	0.0000	0.0000	0.0000
	9	1.3409E-03	3.7707E-06	301.83	154.50	251.03	15.524	59.364	4.6765	2798.9	7.8279E+06	7.8279E+06
x(M)		0.0000	11.070	5.6700	0.0000	0.0000	9.4500	3.2400	11.340	0.0000	0.0000	0.0000
	10	1.3358E-03	4.9233E-06	371.29	218.55	364.62	21.243	94.271	9.3907	5117.3	7.8279E+06	7.8279E+06
x(M)		0.0000	9.9900	5.1300	0.0000	0.0000	8.3700	2.9700	10.260	0.0000	0.0000	0.0000
	11	1.3358E-03	4.0398E-06	321.61	174.50	281.47	17.274	68.411	5.7334	3899.3	7.8279E+06	7.8279E+06
x(M)		0.0000	10.800	5.4000	0.0000	0.0000	9.1800	2.9700	11.070	0.0000	0.0000	0.0000
	12	1.3358E-03	4.0017E-06	323.59	171.65	285.04	17.131	69.432	5.7589	3139.2	7.8279E+06	7.8279E+06
x(M)		0.0000	10.800	5.4000	0.0000	0.0000	8.9100	2.9700	10.800	0.0000	0.0000	0.0000
Max.	1.3510E-03	4.9233E-06	372.81	218.55	366.43	21.243	94.271	9.3907	5117.3	7.8279E+06	7.8279E+06	
Pile N.	1	10	1	10	1	10	1	10	10	1	1	

***** SUMMARY FOR LOAD CASES AND COMBINATIONS *****

***** LOAD CASES RESULTS *****

LOAD CASE : 1

* TABLE L * COMPUTATION ON PILE CAP

* EQUIVALENT CONCENTRATED LOAD AT ORIGIN *

LOAD X, KN	LOAD Y, KN	LOAD Z, KN	MOM X, KN- M	MOM Y, KN- M	MOM Z, KN- M
43857.0	2000.00	-1440.00	-295.000	-23215.0	-24496.0

* DISPLACEMENT OF GROUPED PILE FOUNDATION AT ORIGIN *

DISP X, M	DISP Y, M	DISP Z, M	ROT X,RAD	ROT Y,RAD	ROT Z,RAD
1.87510E-03	7.78671E-04	-4.91944E-04	-9.26210E-07	-4.56480E-05	-9.25026E-05

* PILE TOP DISPLACEMENTS, GLOBAL *

	DISP. X, M	DISP. Y, M	DISP. Z, M	ROT. X,RAD	ROT. Y,RAD	ROT. Z,RAD
MINIMUM	1.1507E-03	7.7242E-04	-4.9611E-04	-9.2621E-07	-4.5648E-05	-9.2503E-05
Pile N.	3	10	1	1	1	1
MAXIMUM	2.5995E-03	7.8492E-04	-4.8778E-04	-9.2621E-07	-4.5648E-05	-9.2503E-05
Pile N.	10	1	3	1	1	1

* PILE TOP REACTIONS, GLOBAL *

	FOR. X, KN	FOR. Y, KN	FOR. Z, KN	MOM X, KN- M	MOM Y, KN- M	MOM Z, KN- M
MINIMUM	2279.6	143.50	-149.42	-0.2459	224.57	280.90
Pile N.	3	5	10	1	5	5
MAXIMUM	5029.9	210.88	-100.60	-0.2459	311.06	393.85
Pile N.	10	10	5	1	10	10

* PILE TOP DISPLACEMENTS, LOCAL *

	DISP. x, M	DISP. y, M	DISP. z, M	ROT. x,RAD	ROT. y,RAD	ROT. z,RAD
MINIMUM	1.1507E-03	7.7242E-04	-4.9611E-04	-9.2621E-07	-4.5648E-05	-9.2503E-05
Pile N.	3	10	1	1	1	1
MAXIMUM	2.5995E-03	7.8492E-04	-4.8778E-04	-9.2621E-07	-4.5648E-05	-9.2503E-05
Pile N.	10	1	3	1	1	1

* PILE TOP REACTIONS, LOCAL *

	AXIAL, KN	LAT. y, KN	LAT. z, KN	MOM x, KN- M	MOM y, KN- M	MOM z, KN- M
MINIMUM	2279.6	143.50	-149.42	-0.2459	224.57	280.90
Pile N.	3	5	10	1	5	5
MAXIMUM	5029.9	210.88	-100.60	-0.2459	311.06	393.85
Pile N.	10	10	5	1	10	10

* EFFECTS FOR LATERALLY LOADED PILE *

PILE	DISPL. y-DIR M	DISPL. z-DIR M	MOMENT z-DIR KN- M	MOMENT y-DIR KN- M	SHEAR y-DIR KN	SHEAR z-DIR KN	SOIL REACT y-DIR KN/ M	SOIL REACT z-DIR KN/ M	TOTAL STRESS KN/ M**2
*****	*****	*****	*****	*****	*****	*****	*****	*****	*****
Min.	-1.1640E-05	-4.9611E-04	-393.85	-137.29	-46.456	-149.45	-21.414	-37.245	1290.0
Pile N.	10	1	10	10	10	10	10	10	3
Max.	7.8492E-04	6.9841E-06	214.68	311.06	210.91	30.166	54.520	13.326	4361.0
Pile N.	1	10	10	10	10	10	10	10	10

LOAD CASE : 2



* TABLE L * COMPUTATION ON PILE CAP

* EQUIVALENT CONCENTRATED LOAD AT ORIGIN *

LOAD X, KN	LOAD Y, KN	LOAD Z, KN	MOM X, KN- M	MOM Y, KN- M	MOM Z, KN- M
33922.0	415.000	-1204.00	-335.000	-18699.0	-6629.50

* DISPLACEMENT OF GROUPED PILE FOUNDATION AT ORIGIN *

DISP X, M	DISP Y, M	DISP Z, M	ROT X,RAD	ROT Y,RAD	ROT Z,RAD
1.43899E-03	1.73799E-04	-4.12259E-04	-2.77772E-06	-3.69954E-05	-2.38671E-05

APPALTATORE: Consorzio Soci   		ITINERARIO NAPOLI – BARI RADDOPPIO TRATTA APICE – ORSARA I LOTTO FUNZIONALE APICE – HIRPINIA
PROGETTAZIONE: Mandataria Mandanti   		
PROGETTO ESECUTIVO RELAZIONE DI CALCOLO FONDAZIONI SPALLA A		

* PILE TOP DISPLACEMENTS, GLOBAL *

	DISP. X, M	DISP. Y, M	DISP. Z, M	ROT. X,RAD	ROT. Y,RAD	ROT. Z,RAD
MINIMUM	1.0819E-03	1.5505E-04	-4.2476E-04	-2.7777E-06	-3.6995E-05	-2.3867E-05
Pile N.	3	10	1	1	1	1
MAXIMUM	1.7961E-03	1.9255E-04	-3.9976E-04	-2.7777E-06	-3.6995E-05	-2.3867E-05
Pile N.	10	1	3	1	1	1

* PILE TOP REACTIONS, GLOBAL *

	FOR. X, KN	FOR. Y, KN	FOR. Z, KN	MOM X, KN- M	MOM Y, KN- M	MOM Z, KN- M
MINIMUM	2148.9	27.985	-130.14	-0.7376	188.88	45.889
Pile N.	3	8	10	1	5	8
MAXIMUM	3504.8	41.747	-83.175	-0.7376	275.10	77.928
Pile N.	10	1	5	1	10	1

* PILE TOP DISPLACEMENTS, LOCAL *

	DISP. X, M	DISP. Y, M	DISP. z, M	ROT. x,RAD	ROT. y,RAD	ROT. z,RAD
MINIMUM	1.0819E-03	1.5505E-04	-4.2476E-04	-2.7777E-06	-3.6995E-05	-2.3867E-05
Pile N.	3	10	1	1	1	1
MAXIMUM	1.7961E-03	1.9255E-04	-3.9976E-04	-2.7777E-06	-3.6995E-05	-2.3867E-05
Pile N.	10	1	3	1	1	1

* PILE TOP REACTIONS, LOCAL *

	AXIAL, KN	LAT. y, KN	LAT. z, KN	MOM x, KN- M	MOM y, KN- M	MOM z, KN- M
MINIMUM	2148.9	27.985	-130.14	-0.7376	188.88	45.889
Pile N.	3	8	10	1	5	8
MAXIMUM	3504.8	41.747	-83.175	-0.7376	275.10	77.928
Pile N.	10	1	5	1	10	1

* EFFECTS FOR LATERALLY LOADED PILE *

PILE	DISPL. y-DIR	DISPL. z-DIR	MOMENT z-DIR	MOMENT y-DIR	SHEAR y-DIR	SHEAR z-DIR	SOIL REACT y-DIR	SOIL REACT z-DIR	TOTAL STRESS
	M	M	KN- M	KN- M	KN	KN	KN/ M	KN/ M	KN/ M**2
Min.	-2.5904E-06	-4.2476E-04	-77.928	-117.53	-9.8682	-130.15	-4.4557	-32.229	1216.0
Pile N.	10	1	1	10	1	10	10	10	3
Max.	1.9255E-04	5.9078E-06	47.580	275.10	41.751	25.864	10.326	11.322	2831.0
Pile N.	1	10	1	10	1	10	1	10	10

LOAD CASE : 3

* TABLE L * COMPUTATION ON PILE CAP

* EQUIVALENT CONCENTRATED LOAD AT ORIGIN *

LOAD X, KN	LOAD Y, KN	LOAD Z, KN	MOM X, KN- M	MOM Y, KN- M	MOM Z, KN- M
39701.0	1383.00	-1177.00	-257.000	-25513.5	-17007.5

* DISPLACEMENT OF GROUPED PILE FOUNDATION AT ORIGIN *

DISP X, M	DISP Y, M	DISP Z, M	ROT X,RAD	ROT Y,RAD	ROT Z,RAD
1.69267E-03	5.28121E-04	-4.32395E-04	-1.40711E-06	-4.83044E-05	-6.38339E-05

* PILE TOP DISPLACEMENTS, GLOBAL *

	DISP. X, M	DISP. Y, M	DISP. Z, M	ROT. X,RAD	ROT. Y,RAD	ROT. Z,RAD
MINIMUM	1.0794E-03	5.1862E-04	-4.3873E-04	-1.4071E-06	-4.8304E-05	-6.3834E-05
Pile N.	3	10	1	1	1	1
MAXIMUM	2.3060E-03	5.3762E-04	-4.2606E-04	-1.4071E-06	-4.8304E-05	-6.3834E-05
Pile N.	10	1	3	1	1	1

* PILE TOP REACTIONS, GLOBAL *

	FOR. X, KN	FOR. Y, KN	FOR. Z, KN	MOM X, KN- M	MOM Y, KN- M	MOM Z, KN- M
MINIMUM	2144.1	96.430	-124.11	-0.3736	165.77	185.07
Pile N.	3	5	10	1	5	8
MAXIMUM	4472.7	139.87	-81.411	-0.3736	241.56	257.13
Pile N.	10	10	5	1	10	10

* PILE TOP DISPLACEMENTS, LOCAL *

	DISP. x, M	DISP. y, M	DISP. z, M	ROT. x,RAD	ROT. y,RAD	ROT. z,RAD
MINIMUM	1.0794E-03	5.1862E-04	-4.3873E-04	-1.4071E-06	-4.8304E-05	-6.3834E-05
Pile N.	3	10	1	1	1	1
MAXIMUM	2.3060E-03	5.3762E-04	-4.2606E-04	-1.4071E-06	-4.8304E-05	-6.3834E-05
Pile N.	10	1	3	1	1	1

* PILE TOP REACTIONS, LOCAL *

	AXIAL, KN	LAT. y, KN	LAT. z, KN	MOM x, KN- M	MOM y, KN- M	MOM z, KN- M
MINIMUM	2144.1	96.430	-124.11	-0.3736	165.77	185.07
Pile N.	3	5	10	1	5	8
MAXIMUM	4472.7	139.87	-81.411	-0.3736	241.56	257.13
Pile N.	10	10	5	1	10	10

APPALTATORE: Consorzio Soci   		ITINERARIO NAPOLI – BARI RADDOPPIO TRATTA APICE – ORSARA I LOTTO FUNZIONALE APICE – HIRPINIA					
PROGETTAZIONE: Mandataria Mandanti   							
PROGETTO ESECUTIVO RELAZIONE DI CALCOLO FONDAZIONI SPALLA A							

* EFFECTS FOR LATERALLY LOADED PILE *

PILE	DISPL. y-DIR M	DISPL. z-DIR M	MOMENT z-DIR KN- M	MOMENT y-DIR KN- M	SHEAR y-DIR KN	SHEAR z-DIR KN	SOIL REACT y-DIR KN/ M	SOIL REACT z-DIR KN/ M	TOTAL STRESS KN/ M**2
*****	*****	*****	*****	*****	*****	*****	*****	*****	*****
Min.	-7.8811E-06	-4.3873E-04	-257.13	-121.56	-31.154	-124.13	-14.422	-31.654	1213.3
Pile N.	10	1	10	10	10	10	10	10	3
Max.	5.3762E-04	6.4270E-06	144.27	241.56	139.89	26.431	36.329	12.023	3595.8
Pile N.	1	10	10	10	10	10	10	10	10

LOAD CASE : 4

* TABLE L * COMPUTATION ON PILE CAP

* EQUIVALENT CONCENTRATED LOAD AT ORIGIN *

LOAD X, KN	LOAD Y, KN	LOAD Z, KN	MOM X, KN- M	MOM Y, KN- M	MOM Z, KN- M
41386.0	3552.00	-3.44324E-04	-1006.00	-485.000	-16446.0

* DISPLACEMENT OF GROUPED PILE FOUNDATION AT ORIGIN *

DISP X, M	DISP Y, M	DISP Z, M	ROT X,RAD	ROT Y,RAD	ROT Z,RAD
1.76663E-03	1.34338E-03	-3.44324E-04	-1.12257E-06	-3.22686E-05	-1.60058E-04

* PILE TOP DISPLACEMENTS, GLOBAL *

	DISP. X, M	DISP. Y, M	DISP. Z, M	ROT. X,RAD	ROT. Y,RAD	ROT. Z,RAD
MINIMUM	8.2856E-04	1.3358E-03	-3.4938E-04	-1.1226E-06	-3.2269E-05	-1.6006E-04
Pile N.	3	10	1	1	1	1
MAXIMUM	2.7047E-03	1.3510E-03	-3.3927E-04	-1.1226E-06	-3.2269E-05	-1.6006E-04
Pile N.	10	1	3	1	1	1

* PILE TOP REACTIONS, GLOBAL *

	FOR. X, KN	FOR. Y, KN	FOR. Z, KN	MOM X, KN- M	MOM Y, KN- M	MOM Z, KN- M
MINIMUM	1668.0	248.71	-105.09	-0.2981	154.08	483.79
Pile N.	3	8	10	1	6	8
MAXIMUM	5229.7	366.38	-70.012	-0.2981	218.55	689.03
Pile N.	10	1	6	1	10	1

* PILE TOP DISPLACEMENTS, LOCAL *

	DISP. X, M	DISP. Y, M	DISP. Z, M	ROT. x,RAD	ROT. y,RAD	ROT. z,RAD
MINIMUM	8.2856E-04	1.3358E-03	-3.4938E-04	-1.1226E-06	-3.2269E-05	-1.6006E-04
Pile N.	3	10	1	1	1	1
MAXIMUM	2.7047E-03	1.3510E-03	-3.3927E-04	-1.1226E-06	-3.2269E-05	-1.6006E-04
Pile N.	10	1	3	1	1	1

* PILE TOP REACTIONS, LOCAL *

	AXIAL, KN	LAT. y, KN	LAT. z, KN	MOM x, KN- M	MOM y, KN- M	MOM z, KN- M
MINIMUM	1668.0	248.71	-105.09	-0.2981	154.08	483.79
Pile N.	3	8	10	1	6	8
MAXIMUM	5229.7	366.38	-70.012	-0.2981	218.55	689.03
Pile N.	10	1	6	1	10	1

* EFFECTS FOR LATERALLY LOADED PILE *

PILE	DISPL. y-DIR M	DISPL. z-DIR M	MOMENT z-DIR KN- M	MOMENT y-DIR KN- M	SHEAR y-DIR KN	SHEAR z-DIR KN	SOIL REACT y-DIR KN/ M	SOIL REACT z-DIR KN/ M	TOTAL STRESS KN/ M**2
*****	*****	*****	*****	*****	*****	*****	*****	*****	*****
Min.	-2.0140E-05	-3.4938E-04	-689.03	-96.688	-80.511	-105.11	-37.044	-26.209	943.90
Pile N.	10	1	10	10	1	10	10	10	3
Max.	1.3510E-03	4.9233E-06	372.81	218.55	366.43	21.243	94.271	9.3907	5117.3
Pile N.	1	10	1	10	1	10	1	10	10

10.2 SPALLA SLU – SLV

GROUP for Windows, Version 2016.10.13

Serial Number : 228330872

Analysis of A Group of Piles
 Subjected to Axial and Lateral Loading

(c) Copyright ENSOFT, Inc., 1987-2015
 All Rights Reserved

Time and Date of Analysis

APPALTATORE: Consorzio Soci   	ITINERARIO NAPOLI – BARI RADDOPPIO TRATTA APICE – ORSARA I LOTTO FUNZIONALE APICE – HIRPINIA
PROGETTAZIONE: Mandataria Mandanti   	
PROGETTO ESECUTIVO RELAZIONE DI CALCOLO FONDAZIONI SPALLA A	COMMESSA IF1N LOTTO 01 E ZZ CODIFICA RG DOCUMENTO MD0000 001 REV. B FOGLIO 57 di 109

Date: February 07, 2020 Time: 10:12:01

***** COMPUTATION RESULTS *****

New Group

***** LOAD CASES RESULTS *****

LOAD CASE : 1
CASE NAME : Load Case
LOAD TYPE : Special, Sp

REDUCTION FACTORS FOR CLOSELY-SPACED PILE GROUPS, COMBINED Y AND Z DIRECTIONS
ESTIMATED USING MOVEMENT IN THE DIRECTION OF PILE CAP DISPLACEMENTS

GROUP NO	P-FACTOR	Y-FACTOR
1	0.8561	1.0000
2	0.5758	1.0000
3	0.5845	1.0000
4	0.7960	1.0000
5	0.4938	1.0000
6	0.4977	1.0000
7	0.7970	1.0000
8	0.4951	1.0000
9	0.4993	1.0000
10	0.8661	1.0000
11	0.5904	1.0000
12	0.5991	1.0000

* TABLE L * COMPUTATION ON PILE CAP

* EQUIVALENT CONCENTRATED LOAD AT ORIGIN *

VERT. LOAD, KN	HOR. LOAD Y, KN	HOR. LOAD Z, KN
32966.0	18789.1	-4279.00
MOMENT X, KN- M	MOMENT Y, KN- M	MOMENT Z, KN- M
-713.000	-45399.2	-1.74685E+05

* DISPLACEMENT OF GROUPED PILE FOUNDATION AT ORIGIN *

VERTICAL, M	HORIZONTAL Y, M	HORIZONTAL Z, M
1.68753E-03	0.0122511	-2.57097E-03
ANGLE ROT. X, RAD	ANGLE ROT. Y, RAD	ANGLE ROT. Z, RAD
1.17591E-05	-1.23722E-04	-8.25963E-04

THE GLOBAL STRUCTURAL COORDINATE SYSTEM

* PILE TOP DISPLACEMENTS *

PILE GROUP	DISP. X, M	DISP. Y, M	DISP. Z, M	ROT. X, RAD	ROT. Y, RAD	ROT. Z, RAD
*****	*****	*****	*****	*****	*****	*****
1	4.5692E-03	0.012172	-2.5180E-03	1.1759E-05	-1.2372E-04	-8.2596E-04
2	8.5240E-04	0.012172	-2.5710E-03	1.1759E-05	-1.2372E-04	-8.2596E-04
3	-2.8644E-03	0.012172	-2.6239E-03	1.1759E-05	-1.2372E-04	-8.2596E-04
4	5.1260E-03	0.012225	-2.5180E-03	1.1759E-05	-1.2372E-04	-8.2596E-04
5	1.4092E-03	0.012225	-2.5710E-03	1.1759E-05	-1.2372E-04	-8.2596E-04
6	-2.3077E-03	0.012225	-2.6239E-03	1.1759E-05	-1.2372E-04	-8.2596E-04
7	5.6827E-03	0.012278	-2.5180E-03	1.1759E-05	-1.2372E-04	-8.2596E-04
8	1.9659E-03	0.012278	-2.5710E-03	1.1759E-05	-1.2372E-04	-8.2596E-04
9	-1.7509E-03	0.012278	-2.6239E-03	1.1759E-05	-1.2372E-04	-8.2596E-04
10	6.2395E-03	0.012330	-2.5180E-03	1.1759E-05	-1.2372E-04	-8.2596E-04
11	2.5226E-03	0.012330	-2.5710E-03	1.1759E-05	-1.2372E-04	-8.2596E-04
12	-1.1942E-03	0.012330	-2.6239E-03	1.1759E-05	-1.2372E-04	-8.2596E-04
MINIMUM	-2.8644E-03	0.012172	-2.6239E-03	1.1759E-05	-1.2372E-04	-8.2596E-04

APPALTATORE:

Consorzio

Soci



ITINERARIO NAPOLI – BARI

PROGETTAZIONE:

Mandatario

Mandanti



RADDOPPIO TRATTA APICE – ORSARA
I LOTTO FUNZIONALE APICE – HIRPINIA

PROGETTO ESECUTIVO

RELAZIONE DI CALCOLO FONDAZIONI SPALLA A

COMMESSA	LOTTO	CODIFICA	DOCUMENTO	REV.	FOGLIO
IF1N	01 E ZZ	RG	MD0000 001	B	58 di 109

Pile N.	3	1	3	1	1	1
MAXIMUM	6.2395E-03	0.012330	-2.5180E-03	1.1759E-05	-1.2372E-04	-8.2596E-04
Pile N.	10	10	1	1	1	1

* PILE TOP REACTIONS *

PILE GROUP	FOR. X, KN	FOR. Y, KN	FOR. Z, KN	MOM X, KN- M	MOM Y, KN- M	MOM Z, KN- M
1	7936.8	1919.6	-428.34	3.1223	1239.3	5202.4
2	1713.3	1458.4	-336.48	3.1223	1045.0	4179.9
3	-5416.5	1481.5	-349.99	3.1223	1081.5	4207.5
4	8641.0	1829.2	-406.53	3.1223	1193.4	5026.6
5	2770.2	1313.3	-302.46	3.1223	967.47	3864.3
6	-4377.4	1328.1	-313.30	3.1223	998.08	3874.2
7	9199.3	1836.4	-405.89	3.1223	1192.5	5056.6
8	3827.1	1319.3	-302.14	3.1223	967.53	3892.6
9	-3338.4	1334.8	-313.09	3.1223	998.38	3903.7
10	9425.9	1953.1	-428.66	3.1223	1241.4	5317.3
11	4884.0	1496.0	-339.28	3.1223	1053.8	4309.2
12	-2299.3	1519.4	-352.84	3.1223	1090.4	4336.8
MINIMUM	-5416.5	1313.3	-428.66	3.1223	967.47	3864.3
Pile N.	3	5	10	1	5	5
MAXIMUM	9425.9	1953.1	-302.14	3.1223	1241.4	5317.3
Pile N.	10	10	8	1	10	10

THE PILE COORDINATE SYSTEM (LOCAL AXES)





* PILE TOP DISPLACEMENTS *

PILE GROUP	DISP. x, M	DISP. y, M	DISP. z, M	ROT. x, RAD	ROT. y, RAD	ROT. z, RAD
1	4.5692E-03	0.012172	-2.5180E-03	1.1759E-05	-1.2372E-04	-8.2596E-04
2	8.5240E-04	0.012172	-2.5710E-03	1.1759E-05	-1.2372E-04	-8.2596E-04
3	-2.8644E-03	0.012172	-2.6239E-03	1.1759E-05	-1.2372E-04	-8.2596E-04
4	5.1260E-03	0.012225	-2.5180E-03	1.1759E-05	-1.2372E-04	-8.2596E-04
5	1.4092E-03	0.012225	-2.5710E-03	1.1759E-05	-1.2372E-04	-8.2596E-04
6	-2.3077E-03	0.012225	-2.6239E-03	1.1759E-05	-1.2372E-04	-8.2596E-04
7	5.6827E-03	0.012278	-2.5180E-03	1.1759E-05	-1.2372E-04	-8.2596E-04
8	1.9659E-03	0.012278	-2.5710E-03	1.1759E-05	-1.2372E-04	-8.2596E-04
9	-1.7509E-03	0.012278	-2.6239E-03	1.1759E-05	-1.2372E-04	-8.2596E-04
10	6.2395E-03	0.012330	-2.5180E-03	1.1759E-05	-1.2372E-04	-8.2596E-04
11	2.5226E-03	0.012330	-2.5710E-03	1.1759E-05	-1.2372E-04	-8.2596E-04
12	-1.1942E-03	0.012330	-2.6239E-03	1.1759E-05	-1.2372E-04	-8.2596E-04
MINIMUM	-2.8644E-03	0.012172	-2.6239E-03	1.1759E-05	-1.2372E-04	-8.2596E-04
Pile N.	3	1	3	1	1	1
MAXIMUM	6.2395E-03	0.012330	-2.5180E-03	1.1759E-05	-1.2372E-04	-8.2596E-04
Pile N.	10	10	1	1	1	1

* PILE TOP REACTIONS *

PILE GROUP	AXIAL, KN	LAT. y, KN	LAT. z, KN	MOM x, KN- M	MOM y, KN- M	MOM z, KN- M
1	7936.8	1919.6	-428.34	3.1223	1239.3	5202.4
2	1713.3	1458.4	-336.48	3.1223	1045.0	4179.9
3	-5416.5	1481.5	-349.99	3.1223	1081.5	4207.5
4	8641.0	1829.2	-406.53	3.1223	1193.4	5026.6
5	2770.2	1313.3	-302.46	3.1223	967.47	3864.3
6	-4377.4	1328.1	-313.30	3.1223	998.08	3874.2
7	9199.3	1836.4	-405.89	3.1223	1192.5	5056.6
8	3827.1	1319.3	-302.14	3.1223	967.53	3892.6
9	-3338.4	1334.8	-313.09	3.1223	998.38	3903.7
10	9425.9	1953.1	-428.66	3.1223	1241.4	5317.3
11	4884.0	1496.0	-339.28	3.1223	1053.8	4309.2
12	-2299.3	1519.4	-352.84	3.1223	1090.4	4336.8
MINIMUM	-5416.5	1313.3	-428.66	3.1223	967.47	3864.3
Pile N.	3	5	10	1	5	5
MAXIMUM	9425.9	1953.1	-302.14	3.1223	1241.4	5317.3
Pile N.	10	10	8	1	10	10

PILE GROUP	STRESS, KN/ M**2
1	2.0632E+04
2	1.3973E+04
3	1.6176E+04
4	2.0482E+04
5	1.3590E+04
6	1.4551E+04
7	2.0885E+04
8	1.4271E+04
9	1.4050E+04
10	2.1813E+04
11	1.6152E+04
12	1.4797E+04

APPALTATORE: Consorzio <u>Soci</u>   		ITINERARIO NAPOLI – BARI					
PROGETTAZIONE: <u>Mandatario</u>   		RADDOPPIO TRATTA APICE – ORSARA I LOTTO FUNZIONALE APICE – HIRPINIA					
PROGETTO ESECUTIVO RELAZIONE DI CALCOLO FONDAZIONI SPALLA A		COMMESSA IF1N	LOTTO 01 E ZZ	CODIFICA RG	DOCUMENTO MD0000 001	REV. B	FOGLIO 59 di 109

MINIMUM 1.3590E+04
 Pile N. 5
 MAXIMUM 2.1813E+04
 Pile N. 10

* EFFECTS FOR LATERALLY LOADED PILE *

* MINIMUM VALUES AND LOCATIONS *

PILE	DISPL. y-DIR M	DISPL. z-DIR M	MOMENT z-DIR KN- M	MOMENT y-DIR KN- M	SHEAR y-DIR KN	SHEAR z-DIR KN	SOIL REACT y-DIR KN/ M	SOIL REACT z-DIR KN/ M	TOTAL STRESS KN/ M**2	FLEX. RIG. z-DIR KN- M**2	FLEX. RIG. y-DIR KN- M**2
*****	*****	*****	*****	*****	*****	*****	*****	*****	*****	*****	*****
1	-6.6645E-05	-2.5181E-03	-5202.4	-483.08	-567.37	-428.51	-181.39	-85.584	4491.3	7.8279E+06	7.8279E+06
x(M)	12.150	0.0000	0.0000	7.0200	10.800	0.0000	12.150	4.3200	27.000	0.0000	0.0000
2	-8.1924E-05	-2.5710E-03	-4179.9	-415.78	-488.30	-336.51	-136.91	-61.582	969.51	7.8279E+06	7.8279E+06
x(M)	12.960	0.0000	0.0000	7.8300	11.340	0.0000	12.960	4.3200	27.000	0.0000	0.0000
3	-8.0676E-05	-2.6239E-03	-4207.5	-425.79	-489.10	-349.89	-137.89	-63.869	3065.1	7.8279E+06	7.8279E+06
x(M)	12.960	0.0000	0.0000	7.8300	11.340	0.0000	12.960	4.3200	27.000	0.0000	0.0000
4	-7.0333E-05	-2.5181E-03	-5026.6	-467.29	-559.19	-406.71	-173.59	-80.101	4889.8	7.8279E+06	7.8279E+06
x(M)	12.150	0.0000	0.0000	7.2900	10.800	0.0000	12.420	4.3200	27.000	0.0000	0.0000
5	-8.9511E-05	-2.5710E-03	-3864.3	-391.71	-459.93	-302.51	-122.42	-58.265	1567.6	7.8279E+06	7.8279E+06
x(M)	13.230	0.0000	0.0000	8.1000	11.610	0.0000	13.230	10.260	27.000	0.0000	0.0000
6	-8.8576E-05	-2.6239E-03	-3874.2	-399.97	-459.45	-313.22	-122.64	-60.299	2477.1	7.8279E+06	7.8279E+06
x(M)	13.230	0.0000	0.0000	8.1000	11.610	0.0000	13.230	10.260	27.000	0.0000	0.0000
7	-7.0778E-05	-2.5181E-03	-5056.6	-467.13	-562.06	-406.08	-174.43	-80.019	5205.7	7.8279E+06	7.8279E+06
x(M)	12.150	0.0000	0.0000	7.2900	10.800	0.0000	12.420	4.3200	27.000	0.0000	0.0000
8	-9.0035E-05	-2.5710E-03	-3892.6	-391.91	-462.65	-302.20	-123.16	-58.201	2165.7	7.8279E+06	7.8279E+06
x(M)	13.230	0.0000	0.0000	8.1000	11.610	0.0000	13.230	10.260	27.000	0.0000	0.0000
9	-8.9062E-05	-2.6239E-03	-3903.7	-400.25	-462.25	-313.03	-123.42	-60.243	1889.1	7.8279E+06	7.8279E+06
x(M)	13.230	0.0000	0.0000	8.1000	11.610	0.0000	13.230	10.260	27.000	0.0000	0.0000
10	-6.7557E-05	-2.5181E-03	-5317.3	-484.19	-577.22	-428.86	-184.86	-85.904	5334.0	7.8279E+06	7.8279E+06
x(M)	12.150	0.0000	0.0000	7.0200	10.800	0.0000	12.150	4.3200	27.000	0.0000	0.0000
11	-8.2297E-05	-2.5710E-03	-4309.2	-419.11	-499.76	-339.37	-140.95	-62.559	2763.8	7.8279E+06	7.8279E+06
x(M)	12.960	0.0000	0.0000	7.8300	11.340	0.0000	12.960	4.3200	27.000	0.0000	0.0000
12	-8.1114E-05	-2.6239E-03	-4336.8	-429.15	-500.33	-352.80	-141.86	-64.863	1301.1	7.8279E+06	7.8279E+06
x(M)	12.690	0.0000	0.0000	7.8300	11.340	0.0000	12.960	4.3200	27.000	0.0000	0.0000
Min.	-9.0035E-05	-2.6239E-03	-5317.3	-484.19	-577.22	-428.86	-184.86	-85.904	969.51	7.8279E+06	7.8279E+06
Pile N.	8	3	10	10	10	10	10	10	2	1	1

* MAXIMUM VALUES AND LOCATIONS *

PILE	DISPL. y-DIR M	DISPL. z-DIR M	MOMENT z-DIR KN- M	MOMENT y-DIR KN- M	SHEAR y-DIR KN	SHEAR z-DIR KN	SOIL REACT y-DIR KN/ M	SOIL REACT z-DIR KN/ M	TOTAL STRESS KN/ M**2	FLEX. RIG. z-DIR KN- M**2	FLEX. RIG. y-DIR KN- M**2
*****	*****	*****	*****	*****	*****	*****	*****	*****	*****	*****	*****
1	0.012172	1.4572E-05	2305.3	1239.3	1920.3	124.25	392.37	39.670	2.0632E+04	7.8279E+06	7.8279E+06
x(M)	0.0000	12.150	6.7500	0.0000	0.0000	10.800	4.3200	12.420	0.0000	0.0000	0.0000
2	0.012172	1.8518E-05	1934.5	1045.0	1458.5	109.86	275.39	31.019	1.3973E+04	7.8279E+06	7.8279E+06
x(M)	0.0000	12.960	7.5600	0.0000	0.0000	11.340	4.3200	13.230	0.0000	0.0000	0.0000
3	0.012172	1.8678E-05	1939.2	1081.5	1481.1	112.68	279.15	31.976	1.6176E+04	7.8279E+06	7.8279E+06
x(M)	0.0000	12.960	7.5600	0.0000	0.0000	11.340	4.3200	13.230	0.0000	0.0000	0.0000
4	0.012225	1.5258E-05	2240.8	1193.4	1829.9	121.35	369.06	38.036	2.0482E+04	7.8279E+06	7.8279E+06
x(M)	0.0000	12.150	7.0200	0.0000	0.0000	10.800	4.3200	12.420	0.0000	0.0000	0.0000
5	0.012225	2.0117E-05	1825.6	967.47	1313.5	103.28	239.96	27.689	1.3590E+04	7.8279E+06	7.8279E+06
x(M)	0.0000	13.230	7.8300	0.0000	0.0000	11.610	4.3200	13.500	0.0000	0.0000	0.0000
6	0.012225	2.0384E-05	1824.3	998.08	1327.9	105.60	241.95	28.414	1.4551E+04	7.8279E+06	7.8279E+06
x(M)	0.0000	13.230	7.8300	0.0000	0.0000	11.610	10.260	13.500	0.0000	0.0000	0.0000
7	0.012278	1.5276E-05	2250.1	1192.5	1837.2	121.34	370.58	38.017	2.0885E+04	7.8279E+06	7.8279E+06
x(M)	0.0000	12.150	7.0200	0.0000	0.0000	10.800	4.3200	12.420	0.0000	0.0000	0.0000
8	0.012278	2.0129E-05	1834.9	967.53	1319.6	103.35	241.18	27.703	1.4271E+04	7.8279E+06	7.8279E+06
x(M)	0.0000	13.230	7.8300	0.0000	0.0000	11.610	4.3200	13.500	0.0000	0.0000	0.0000
9	0.012278	2.0388E-05	1834.0	998.38	1334.5	105.69	243.26	28.438	1.4050E+04	7.8279E+06	7.8279E+06
x(M)	0.0000	13.230	7.8300	0.0000	0.0000	11.610	10.260	13.500	0.0000	0.0000	0.0000
10	0.012330	1.4546E-05	2341.7	1241.4	1954.0	124.48	399.99	39.803	2.1813E+04	7.8279E+06	7.8279E+06
x(M)	0.0000	12.150	6.7500	0.0000	0.0000	10.800	4.3200	12.150	0.0000	0.0000	0.0000
11	0.012330	1.8320E-05	1977.3	1053.8	1496.4	110.81	284.15	31.377	1.6152E+04	7.8279E+06	7.8279E+06
x(M)	0.0000	12.960	7.5600	0.0000	0.0000	11.340	4.3200	12.960	0.0000	0.0000	0.0000
12	0.012330	1.8473E-05	1981.9	1090.4	1519.2	113.58	287.94	32.342	1.4797E+04	7.8279E+06	7.8279E+06
x(M)	0.0000	12.960	7.5600	0.0000	0.0000	11.340	4.3200	12.960	0.0000	0.0000	0.0000
Max.	0.012330	2.0388E-05	2341.7	1241.4	1954.0	124.48	399.99	39.803	2.1813E+04	7.8279E+06	7.8279E+06
Pile N.	10	9	10	10	10	10	10	10	10	1	1

LOAD CASE : 2
 CASE NAME : Load Case
 LOAD TYPE : Special, Sp

REDUCTION FACTORS FOR CLOSELY-SPACED PILE GROUPS, COMBINED Y AND Z DIRECTIONS
 ESTIMATED USING MOVEMENT IN THE DIRECTION OF PILE CAP DISPLACEMENTS

GROUP NO	P-FACTOR	Y-FACTOR
1	0.6004	1.0000

APPALTATORE: Consorzio Soci   	ITINERARIO NAPOLI – BARI RADDOPPIO TRATTA APICE – ORSARA I LOTTO FUNZIONALE APICE – HIRPINIA
PROGETTAZIONE: Mandataria Mandanti   	
PROGETTO ESECUTIVO RELAZIONE DI CALCOLO FONDAZIONI SPALLA A	COMMESSA LOTTO CODIFICA DOCUMENTO REV. FOGLIO IF1N 01 E ZZ RG MD0000 001 B 60 di 109

2	0.5914	1.0000
3	0.8661	1.0000
4	0.4997	1.0000
5	0.4952	1.0000
6	0.7963	1.0000
7	0.4979	1.0000
8	0.4936	1.0000
9	0.7951	1.0000
10	0.5845	1.0000
11	0.5755	1.0000
12	0.8551	1.0000

* TABLE L * COMPUTATION ON PILE CAP

* EQUIVALENT CONCENTRATED LOAD AT ORIGIN *

VERT. LOAD, KN 40273.0	HOR. LOAD Y, KN -17902.5	HOR. LOAD Z, KN 4217.40
MOMENT X, KN- M 656.000	MOMENT Y, KN- M 46241.8	MOMENT Z, KN- M 1.58806E+05

* DISPLACEMENT OF GROUPED PILE FOUNDATION AT ORIGIN *

VERTICAL, M 2.02718E-03	HORIZONTAL Y, M -0.0112945	HORIZONTAL Z, M 2.48443E-03
ANGLE ROT. X, RAD 3.16456E-05	ANGLE ROT. Y, RAD 1.25887E-04	ANGLE ROT. Z, RAD 7.68267E-04

THE GLOBAL STRUCTURAL COORDINATE SYSTEM

* PILE TOP DISPLACEMENTS *

PILE GROUP	DISP. X, M	DISP. Y, M	DISP. Z, M	ROT. X, RAD	ROT. Y, RAD	ROT. Z, RAD
*****	*****	*****	*****	*****	*****	*****
1	-5.8029E-04	-0.011508	2.6268E-03	3.1646E-05	1.2589E-04	7.6827E-04
2	2.8769E-03	-0.011508	2.4844E-03	3.1646E-05	1.2589E-04	7.6827E-04
3	6.3341E-03	-0.011508	2.3420E-03	3.1646E-05	1.2589E-04	7.6827E-04
4	-1.1468E-03	-0.011366	2.6268E-03	3.1646E-05	1.2589E-04	7.6827E-04
5	2.3104E-03	-0.011366	2.4844E-03	3.1646E-05	1.2589E-04	7.6827E-04
6	5.7676E-03	-0.011366	2.3420E-03	3.1646E-05	1.2589E-04	7.6827E-04
7	-1.7133E-03	-0.011223	2.6268E-03	3.1646E-05	1.2589E-04	7.6827E-04
8	1.7439E-03	-0.011223	2.4844E-03	3.1646E-05	1.2589E-04	7.6827E-04
9	5.2011E-03	-0.011223	2.3420E-03	3.1646E-05	1.2589E-04	7.6827E-04
10	-2.2798E-03	-0.011081	2.6268E-03	3.1646E-05	1.2589E-04	7.6827E-04
11	1.1774E-03	-0.011081	2.4844E-03	3.1646E-05	1.2589E-04	7.6827E-04
12	4.6346E-03	-0.011081	2.3420E-03	3.1646E-05	1.2589E-04	7.6827E-04
MINIMUM	-2.2798E-03	-0.011508	2.3420E-03	3.1646E-05	1.2589E-04	7.6827E-04
Pile N.	10	1	3	1	1	1
MAXIMUM	6.3341E-03	-0.011081	2.6268E-03	3.1646E-05	1.2589E-04	7.6827E-04
Pile N.	3	10	1	1	1	1

* PILE TOP REACTIONS *

PILE GROUP	FOR. X, KN	FOR. Y, KN	FOR. Z, KN	MOM X, KN- M	MOM Y, KN- M	MOM Z, KN- M
*****	*****	*****	*****	*****	*****	*****
1	-1150.4	-1462.3	362.31	8.4026	-1106.7	-4146.0
2	5556.6	-1441.4	334.09	8.4026	-1018.5	-4120.9
3	9464.4	-1882.6	403.68	8.4026	-1140.5	-5082.2
4	-2210.8	-1274.2	322.20	8.4026	-1014.7	-3690.1
5	4481.2	-1260.7	298.06	8.4026	-935.68	-3680.5
6	9233.9	-1757.2	383.26	8.4026	-1096.9	-4783.1
7	-3268.1	-1258.7	323.57	8.4026	-1016.9	-3622.3
8	3405.7	-1245.9	299.47	8.4026	-938.01	-3614.0
9	8736.1	-1738.5	385.33	8.4026	-1100.6	-4707.4
10	-4325.3	-1394.3	362.93	8.4026	-1105.1	-3892.5
11	2330.3	-1374.1	334.64	8.4026	-1016.9	-3868.3
12	8019.5	-1812.6	407.84	8.4026	-1147.4	-4824.9
MINIMUM	-4325.3	-1882.6	298.06	8.4026	-1147.4	-5082.2
Pile N.	10	3	5	1	12	3
MAXIMUM	9464.4	-1245.9	407.84	8.4026	-935.68	-3614.0
Pile N.	3	8	12	1	5	8

THE PILE COORDINATE SYSTEM (LOCAL AXES)

APPALTATORE: Consorzio HirpiniaAV Soci salini impreglio ASTALDI		ITINERARIO NAPOLI – BARI RADDOPPIO TRATTA APICE – ORSARA I LOTTO FUNZIONALE APICE – HIRPINIA			
PROGETTAZIONE: Mandataria ROKSOJL Mandanti NETENGINEERING Alpina					
PROGETTO ESECUTIVO RELAZIONE DI CALCOLO FONDAZIONI SPALLA A					
COMMESSA	LOTTO	CODIFICA	DOCUMENTO	REV.	FOGLIO
IF1N	01 E ZZ	RG	MD0000 001	B	61 di 109

* PILE TOP DISPLACEMENTS *

PILE GROUP	DISP. x, M	DISP. y, M	DISP. z, M	ROT. x,RAD	ROT. y,RAD	ROT. z,RAD
*****	*****	*****	*****	*****	*****	*****
1	-5.8029E-04	-0.011508	2.6268E-03	3.1646E-05	1.2589E-04	7.6827E-04
2	2.8769E-03	-0.011508	2.4844E-03	3.1646E-05	1.2589E-04	7.6827E-04
3	6.3341E-03	-0.011508	2.3420E-03	3.1646E-05	1.2589E-04	7.6827E-04
4	-1.1468E-03	-0.011366	2.6268E-03	3.1646E-05	1.2589E-04	7.6827E-04
5	2.3104E-03	-0.011366	2.4844E-03	3.1646E-05	1.2589E-04	7.6827E-04
6	5.7676E-03	-0.011366	2.3420E-03	3.1646E-05	1.2589E-04	7.6827E-04
7	-1.7133E-03	-0.011223	2.6268E-03	3.1646E-05	1.2589E-04	7.6827E-04
8	1.7439E-03	-0.011223	2.4844E-03	3.1646E-05	1.2589E-04	7.6827E-04
9	5.2011E-03	-0.011223	2.3420E-03	3.1646E-05	1.2589E-04	7.6827E-04
10	-2.2798E-03	-0.011081	2.6268E-03	3.1646E-05	1.2589E-04	7.6827E-04
11	1.1774E-03	-0.011081	2.4844E-03	3.1646E-05	1.2589E-04	7.6827E-04
12	4.6346E-03	-0.011081	2.3420E-03	3.1646E-05	1.2589E-04	7.6827E-04
MINIMUM	-2.2798E-03	-0.011508	2.3420E-03	3.1646E-05	1.2589E-04	7.6827E-04
Pile N.	10	1	3	1	1	1
MAXIMUM	6.3341E-03	-0.011081	2.6268E-03	3.1646E-05	1.2589E-04	7.6827E-04
Pile N.	3	10	1	1	1	1

* PILE TOP REACTIONS *

PILE GROUP	AXIAL, KN	LAT. y, KN	LAT. z, KN	MOM x, KN- M	MOM y, KN- M	MOM z, KN- M
*****	*****	*****	*****	*****	*****	*****
1	-1150.4	-1462.3	362.31	8.4026	-1106.7	-4146.0
2	5556.6	-1441.4	334.09	8.4026	-1018.5	-4120.9
3	9464.4	-1882.6	403.68	8.4026	-1140.5	-5082.2
4	-2210.8	-1274.2	322.20	8.4026	-1014.7	-3690.1
5	4481.2	-1260.7	298.06	8.4026	-935.68	-3680.5
6	9233.9	-1757.2	383.26	8.4026	-1096.9	-4783.1
7	-3268.1	-1258.7	323.57	8.4026	-1016.9	-3622.3
8	3405.7	-1245.9	299.47	8.4026	-938.01	-3614.0
9	8736.1	-1738.5	385.33	8.4026	-1100.6	-4707.4
10	-4325.3	-1394.3	362.93	8.4026	-1105.1	-3892.5
11	2330.3	-1374.1	334.64	8.4026	-1016.9	-3868.3
12	8019.5	-1812.6	407.84	8.4026	-1147.4	-4824.9
MINIMUM	-4325.3	-1882.6	298.06	8.4026	-1147.4	-5082.2
Pile N.	10	3	5	1	12	3
MAXIMUM	9464.4	-1245.9	407.84	8.4026	-935.68	-3614.0
Pile N.	3	8	12	1	5	8

PILE GROUP	STRESS, KN/ M**2
*****	*****
1	1.3602E+04
2	1.5956E+04
3	2.1076E+04
4	1.2801E+04
5	1.3997E+04
6	2.0036E+04
7	1.3204E+04
8	1.3196E+04
9	1.9534E+04
10	1.4660E+04
11	1.3390E+04
12	1.9506E+04
MINIMUM	1.2801E+04
Pile N.	4
MAXIMUM	2.1076E+04
Pile N.	3

* EFFECTS FOR LATERALLY LOADED PILE *

* MINIMUM VALUES AND LOCATIONS *

PILE	DISPL. y-DIR M	DISPL. z-DIR M	MOMENT z-DIR KN- M	MOMENT y-DIR KN- M	SHEAR y-DIR KN	SHEAR z-DIR KN	SOIL REACT y-DIR KN/ M	SOIL REACT z-DIR KN/ M	TOTAL STRESS KN/ M**2	FLEX. RIG. z-DIR KN- M**2	FLEX. RIG. y-DIR KN- M**2
*****	*****	*****	*****	*****	*****	*****	*****	*****	*****	*****	*****
1	-0.011508	-1.7998E-05	-1877.6	-1106.7	-1462.2	-114.64	-277.35	-33.038	651.00	7.8279E+06	7.8279E+06
x(M)	0.0000	12.690	7.2900	0.0000	0.0000	11.340	4.3200	12.960	27.000	0.0000	0.0000
2	-0.011508	-1.7111E-05	-1872.9	-1018.5	-1441.8	-107.34	-273.87	-30.766	3144.4	7.8279E+06	7.8279E+06
x(M)	0.0000	12.690	7.5600	0.0000	0.0000	11.340	4.3200	12.960	27.000	0.0000	0.0000
3	-0.011508	-1.3078E-05	-2222.5	-1140.5	-1883.5	-115.10	-384.91	-37.453	5355.8	7.8279E+06	7.8279E+06
x(M)	0.0000	11.880	6.7500	0.0000	0.0000	10.800	4.3200	12.150	27.000	0.0000	0.0000
4	-0.011366	-1.9896E-05	-1723.4	-1014.7	-1274.0	-106.95	-232.89	-29.056	1251.1	7.8279E+06	7.8279E+06
x(M)	0.0000	13.230	7.8300	0.0000	0.0000	11.610	4.3200	13.500	27.000	0.0000	0.0000
5	-0.011366	-1.8844E-05	-1724.3	-935.68	-1261.0	-100.33	-231.21	-27.154	2535.8	7.8279E+06	7.8279E+06
x(M)	0.0000	13.230	7.8300	0.0000	0.0000	11.610	4.3200	13.500	27.000	0.0000	0.0000
6	-0.011366	-1.3682E-05	-2118.2	-1096.9	-1758.0	-112.55	-354.37	-35.538	5225.3	7.8279E+06	7.8279E+06
x(M)	0.0000	12.150	7.0200	0.0000	0.0000	10.800	4.3200	12.420	27.000	0.0000	0.0000
7	-0.011223	-1.9848E-05	-1702.4	-1016.9	-1258.5	-107.06	-230.12	-29.122	1849.4	7.8279E+06	7.8279E+06
x(M)	0.0000	13.230	7.8300	0.0000	0.0000	11.610	4.3200	13.500	27.000	0.0000	0.0000
8	-0.011223	-1.8791E-05	-1703.6	-938.01	-1246.1	-100.45	-228.59	-27.236	1927.3	7.8279E+06	7.8279E+06
x(M)	0.0000	13.230	7.8300	0.0000	0.0000	11.610	4.3200	13.230	27.000	0.0000	0.0000

APPALTATORE: Consorzio HirpiniaAV Soci salini impregilo ASTALDI		ITINERARIO NAPOLI – BARI RADDOPPIO TRATTA APICE – ORSARA I LOTTO FUNZIONALE APICE – HIRPINIA			
PROGETTAZIONE: Mandataria ROKSOJL Mandanti NETENGINEERING Alpina					
PROGETTO ESECUTIVO RELAZIONE DI CALCOLO FONDAZIONI SPALLA A					
COMMESSA	LOTTO	CODIFICA	DOCUMENTO	REV.	FOGLIO
IF1N	01 E ZZ	RG	MD0000 001	B	62 di 109

9	-0.011223	-1.3636E-05	-2095.9	-1100.6	-1739.2	-112.73	-350.83	-35.654	4943.6	7.8279E+06	7.8279E+06
x(M)	0.0000	12.150	7.0200	0.0000	0.0000	10.800	4.3200	12.420	27.000	0.0000	0.0000
10	-0.011081	-1.8025E-05	-1800.1	-1105.1	-1394.0	-114.31	-263.72	-32.904	2447.6	7.8279E+06	7.8279E+06
x(M)	0.0000	12.690	7.2900	0.0000	0.0000	11.340	4.3200	12.960	27.000	0.0000	0.0000
11	-0.011081	-1.7142E-05	-1795.3	-1016.9	-1374.3	-107.02	-260.35	-30.637	1318.7	7.8279E+06	7.8279E+06
x(M)	0.0000	12.960	7.2900	0.0000	0.0000	11.340	4.3200	12.960	27.000	0.0000	0.0000
12	-0.011081	-1.3080E-05	-2146.7	-1147.4	-1813.3	-115.40	-370.67	-37.749	4538.1	7.8279E+06	7.8279E+06
x(M)	0.0000	11.880	6.7500	0.0000	0.0000	10.800	4.3200	12.150	27.000	0.0000	0.0000
Min.	-0.011508	-1.9896E-05	-2222.5	-1147.4	-1883.5	-115.40	-384.91	-37.749	651.00	7.8279E+06	7.8279E+06
Pile N.	1	4	3	12	3	12	3	12	1	1	1

* MAXIMUM VALUES AND LOCATIONS *

PILE	DISPL. y-DIR M	DISPL. z-DIR M	MOMENT z-DIR KN- M	MOMENT y-DIR KN- M	SHEAR y-DIR KN	SHEAR z-DIR KN	SOIL REACT y-DIR KN/ M	SOIL REACT z-DIR KN/ M	TOTAL STRESS KN/ M**2	FLEX. RIG. z-DIR KN- M**2	FLEX. RIG. y-DIR KN- M**2
*****	*****	*****	*****	*****	*****	*****	*****	*****	*****	*****	*****
1	7.4451E-05	2.6268E-03	4146.0	435.29	471.57	362.29	135.47	66.824	1.3602E+04	7.8279E+06	7.8279E+06
x(M)	12.690	0.0000	0.0000	7.5600	11.340	0.0000	12.960	4.3200	0.0000	0.0000	0.0000
2	7.5475E-05	2.4844E-03	4120.9	409.71	471.11	334.19	134.67	61.937	1.5956E+04	7.8279E+06	7.8279E+06
x(M)	12.690	0.0000	0.0000	7.5600	11.340	0.0000	12.960	4.3200	0.0000	0.0000	0.0000
3	6.2286E-05	2.3420E-03	5082.2	456.02	546.36	403.87	176.86	81.276	2.1076E+04	7.8279E+06	7.8279E+06
x(M)	11.880	0.0000	0.0000	7.0200	10.530	0.0000	12.150	4.3200	0.0000	0.0000	0.0000
4	8.0407E-05	2.6268E-03	3690.1	406.24	432.34	322.16	117.30	60.410	1.2801E+04	7.8279E+06	7.8279E+06
x(M)	13.230	0.0000	0.0000	8.1000	11.610	0.0000	13.230	10.260	0.0000	0.0000	0.0000
5	8.1270E-05	2.4844E-03	3680.5	383.10	432.69	298.13	117.10	55.654	1.3997E+04	7.8279E+06	7.8279E+06
x(M)	13.230	0.0000	0.0000	8.1000	11.610	0.0000	13.230	10.260	0.0000	0.0000	0.0000
6	6.3795E-05	2.3420E-03	4783.1	440.44	524.51	383.43	164.96	75.962	2.0036E+04	7.8279E+06	7.8279E+06
x(M)	12.150	0.0000	0.0000	7.0200	10.800	0.0000	12.150	4.3200	0.0000	0.0000	0.0000
7	7.8987E-05	2.6268E-03	3622.3	406.69	425.99	323.51	115.78	60.570	1.3204E+04	7.8279E+06	7.8279E+06
x(M)	12.960	0.0000	0.0000	8.1000	11.610	0.0000	13.230	10.260	0.0000	0.0000	0.0000
8	7.9835E-05	2.4844E-03	3614.0	383.60	426.40	299.53	115.63	55.810	1.3196E+04	7.8279E+06	7.8279E+06
x(M)	12.960	0.0000	0.0000	8.1000	11.610	0.0000	13.230	10.260	0.0000	0.0000	0.0000
9	6.2615E-05	2.3420E-03	4707.4	441.63	517.31	385.49	163.14	76.346	1.9534E+04	7.8279E+06	7.8279E+06
x(M)	12.150	0.0000	0.0000	7.0200	10.800	0.0000	12.150	4.3200	0.0000	0.0000	0.0000
10	7.1257E-05	2.6268E-03	3892.5	434.04	448.97	362.85	128.77	66.492	1.4660E+04	7.8279E+06	7.8279E+06
x(M)	12.690	0.0000	0.0000	7.8300	11.340	0.0000	12.960	4.3200	0.0000	0.0000	0.0000
11	7.2235E-05	2.4844E-03	3868.3	408.46	448.48	334.68	127.98	61.616	1.3390E+04	7.8279E+06	7.8279E+06
x(M)	12.690	0.0000	0.0000	7.5600	11.340	0.0000	12.960	4.3200	0.0000	0.0000	0.0000
12	5.9572E-05	2.3420E-03	4824.9	457.91	526.22	408.00	170.20	81.891	1.9506E+04	7.8279E+06	7.8279E+06
x(M)	11.880	0.0000	0.0000	7.0200	10.530	0.0000	12.150	4.3200	0.0000	0.0000	0.0000
Max.	8.1270E-05	2.6268E-03	5082.2	457.91	546.36	408.00	176.86	81.891	2.1076E+04	7.8279E+06	7.8279E+06
Pile N.	5	1	3	12	3	12	3	12	3	1	1

LOAD CASE : 3
CASE NAME : Load Case
LOAD TYPE : Special, Sp

REDUCTION FACTORS FOR CLOSELY-SPACED PILE GROUPS, COMBINED Y AND Z DIRECTIONS ESTIMATED USING MOVEMENT IN THE DIRECTION OF PILE CAP DISPLACEMENTS

GROUP NO	P-FACTOR	Y-FACTOR
1	0.6445	1.0000
2	0.5124	1.0000
3	0.5845	1.0000
4	0.6000	1.0000
5	0.4686	1.0000
6	0.5360	1.0000
7	0.6260	1.0000
8	0.4960	1.0000
9	0.5649	1.0000
10	0.8661	1.0000
11	0.7694	1.0000
12	0.8224	1.0000

* TABLE L * COMPUTATION ON PILE CAP

* EQUIVALENT CONCENTRATED LOAD AT ORIGIN *

VERT. LOAD, KN	HOR. LOAD Y, KN	HOR. LOAD Z, KN
33688.0	5952.10	-14214.2
MOMENT X, KN- M	MOMENT Y, KN- M	MOMENT Z, KN- M
-2207.00	-1.52276E+05	-57250.1

* DISPLACEMENT OF GROUPED PILE FOUNDATION AT ORIGIN *

APPALTATORE:

Consorzio

Soci



ITINERARIO NAPOLI – BARI

PROGETTAZIONE:

Mandataria

Mandanti



RADDOPPIO TRATTA APICE – ORSARA
I LOTTO FUNZIONALE APICE – HIRPINIA

PROGETTO ESECUTIVO

RELAZIONE DI CALCOLO FONDAZIONI SPALLA A

COMMESSA
IF1N

LOTTO
01 E ZZ

CODIFICA
RG

DOCUMENTO
MD0000 001

REV.
B

FOGLIO
63 di 109

VERTICAL , M 1.51871E-03	HORIZONTAL Y, M 3.41860E-03	HORIZONTAL Z, M -7.28611E-03
ANGLE ROT. X,RAD -4.36765E-05	ANGLE ROT. Y,RAD -3.49585E-04	ANGLE ROT. Z,RAD -2.52366E-04

THE GLOBAL STRUCTURAL COORDINATE SYSTEM

* PILE TOP DISPLACEMENTS *

PILE GROUP	DISP. X, M	DISP. Y, M	DISP. Z, M	ROT. X,RAD	ROT. Y,RAD	ROT. Z,RAD
*****	*****	*****	*****	*****	*****	*****
1	2.9465E-04	3.7134E-03	-7.4827E-03	-4.3677E-05	-3.4959E-04	-2.5237E-04
2	-8.4099E-04	3.7134E-03	-7.2861E-03	-4.3677E-05	-3.4959E-04	-2.5237E-04
3	-1.9766E-03	3.7134E-03	-7.0896E-03	-4.3677E-05	-3.4959E-04	-2.5237E-04
4	1.8678E-03	3.5169E-03	-7.4827E-03	-4.3677E-05	-3.4959E-04	-2.5237E-04
5	7.3214E-04	3.5169E-03	-7.2861E-03	-4.3677E-05	-3.4959E-04	-2.5237E-04
6	-4.0350E-04	3.5169E-03	-7.0896E-03	-4.3677E-05	-3.4959E-04	-2.5237E-04
7	3.4409E-03	3.3203E-03	-7.4827E-03	-4.3677E-05	-3.4959E-04	-2.5237E-04
8	2.3053E-03	3.3203E-03	-7.2861E-03	-4.3677E-05	-3.4959E-04	-2.5237E-04
9	1.1696E-03	3.3203E-03	-7.0896E-03	-4.3677E-05	-3.4959E-04	-2.5237E-04
10	5.0141E-03	3.1238E-03	-7.4827E-03	-4.3677E-05	-3.4959E-04	-2.5237E-04
11	3.8784E-03	3.1238E-03	-7.2861E-03	-4.3677E-05	-3.4959E-04	-2.5237E-04
12	2.7428E-03	3.1238E-03	-7.0896E-03	-4.3677E-05	-3.4959E-04	-2.5237E-04
MINIMUM	-1.9766E-03	3.1238E-03	-7.4827E-03	-4.3677E-05	-3.4959E-04	-2.5237E-04
Pile N.	3	10	1	1	1	1
MAXIMUM	5.0141E-03	3.7134E-03	-7.0896E-03	-4.3677E-05	-3.4959E-04	-2.5237E-04
Pile N.	10	1	3	1	1	1

* PILE TOP REACTIONS *

PILE GROUP	FOR. X, KN	FOR. Y, KN	FOR. Z, KN	MOM X, KN- M	MOM Y, KN- M	MOM Z, KN- M
*****	*****	*****	*****	*****	*****	*****
1	601.26	562.78	-1235.3	-11.597	3582.9	1510.5
2	-1640.1	483.96	-1034.2	-11.597	3101.3	1339.7
3	-3759.6	537.27	-1107.5	-11.597	3213.3	1451.3
4	3640.9	499.55	-1179.0	-11.597	3467.9	1335.6
5	1485.0	423.74	-975.17	-11.597	2976.0	1169.7
6	-799.93	471.90	-1046.4	-11.597	3086.5	1271.4
7	6509.5	478.37	-1216.6	-11.597	3553.2	1248.7
8	4471.4	409.35	-1016.0	-11.597	3071.4	1099.4
9	2315.5	455.06	-1087.6	-11.597	3180.6	1194.8
10	8499.5	559.34	-1525.8	-11.597	4194.8	1366.3
11	7062.9	519.28	-1377.9	-11.597	3842.5	1284.9
12	5301.9	551.50	-1412.8	-11.597	3860.3	1346.9
MINIMUM	-3759.6	409.35	-1525.8	-11.597	2976.0	1099.4
Pile N.	3	8	10	1	5	8
MAXIMUM	8499.5	562.78	-975.17	-11.597	4194.8	1510.5
Pile N.	10	1	5	1	10	1

THE PILE COORDINATE SYSTEM (LOCAL AXES)

* PILE TOP DISPLACEMENTS *

PILE GROUP	DISP. x, M	DISP. y, M	DISP. z, M	ROT. x,RAD	ROT. y,RAD	ROT. z,RAD
*****	*****	*****	*****	*****	*****	*****
1	2.9465E-04	3.7134E-03	-7.4827E-03	-4.3677E-05	-3.4959E-04	-2.5237E-04
2	-8.4099E-04	3.7134E-03	-7.2861E-03	-4.3677E-05	-3.4959E-04	-2.5237E-04
3	-1.9766E-03	3.7134E-03	-7.0896E-03	-4.3677E-05	-3.4959E-04	-2.5237E-04
4	1.8678E-03	3.5169E-03	-7.4827E-03	-4.3677E-05	-3.4959E-04	-2.5237E-04
5	7.3214E-04	3.5169E-03	-7.2861E-03	-4.3677E-05	-3.4959E-04	-2.5237E-04
6	-4.0350E-04	3.5169E-03	-7.0896E-03	-4.3677E-05	-3.4959E-04	-2.5237E-04
7	3.4409E-03	3.3203E-03	-7.4827E-03	-4.3677E-05	-3.4959E-04	-2.5237E-04
8	2.3053E-03	3.3203E-03	-7.2861E-03	-4.3677E-05	-3.4959E-04	-2.5237E-04
9	1.1696E-03	3.3203E-03	-7.0896E-03	-4.3677E-05	-3.4959E-04	-2.5237E-04
10	5.0141E-03	3.1238E-03	-7.4827E-03	-4.3677E-05	-3.4959E-04	-2.5237E-04
11	3.8784E-03	3.1238E-03	-7.2861E-03	-4.3677E-05	-3.4959E-04	-2.5237E-04
12	2.7428E-03	3.1238E-03	-7.0896E-03	-4.3677E-05	-3.4959E-04	-2.5237E-04
MINIMUM	-1.9766E-03	3.1238E-03	-7.4827E-03	-4.3677E-05	-3.4959E-04	-2.5237E-04
Pile N.	3	10	1	1	1	1
MAXIMUM	5.0141E-03	3.7134E-03	-7.0896E-03	-4.3677E-05	-3.4959E-04	-2.5237E-04
Pile N.	10	1	3	1	1	1

* PILE TOP REACTIONS *

PILE GROUP	AXIAL, KN	LAT. y, KN	LAT. z, KN	MOM x, KN- M	MOM y, KN- M	MOM z, KN- M
*****	*****	*****	*****	*****	*****	*****
1	601.26	562.78	-1235.3	-11.597	3582.9	1510.5
2	-1640.1	483.96	-1034.2	-11.597	3101.3	1339.7
3	-3759.6	537.27	-1107.5	-11.597	3213.3	1451.3
4	3640.9	499.55	-1179.0	-11.597	3467.9	1335.6

APPALTATORE: Consorzio Soci   		ITINERARIO NAPOLI – BARI RADDOPPIO TRATTA APICE – ORSARA I LOTTO FUNZIONALE APICE – HIRPINIA					
PROGETTAZIONE: Mandataria Mandanti   							
PROGETTO ESECUTIVO RELAZIONE DI CALCOLO FONDAZIONI SPALLA A		COMMESSA IF1N	LOTTO 01 E ZZ	CODIFICA RG	DOCUMENTO MD0000 001	REV. B	FOGLIO 64 di 109

5	1485.0	423.74	-975.17	-11.597	2976.0	1169.7
6	-799.93	471.90	-1046.4	-11.597	3086.5	1271.4
7	6509.5	478.37	-1216.6	-11.597	3553.2	1248.7
8	4471.4	409.35	-1016.0	-11.597	3071.4	1099.4
9	2315.5	455.06	-1087.6	-11.597	3180.6	1194.8
10	8499.5	559.34	-1525.8	-11.597	4194.8	1366.3
11	7062.9	519.28	-1377.9	-11.597	3842.5	1284.9
12	5301.9	551.50	-1412.8	-11.597	3860.3	1346.9
MINIMUM	-3759.6	409.35	-1525.8	-11.597	2976.0	1099.4
Pile N.	3	8	10	1	5	8
MAXIMUM	8499.5	562.78	-975.17	-11.597	4194.8	1510.5
Pile N.	10	1	5	1	10	1

PILE GROUP	STRESS, KN/ M**2
*****	*****
1	1.2075E+04
2	1.1124E+04
3	1.2769E+04
4	1.3276E+04
5	1.0491E+04
6	1.0527E+04
7	1.5050E+04
8	1.2376E+04
9	1.1565E+04
10	1.8124E+04
11	1.6225E+04
12	1.5340E+04
MINIMUM	1.0491E+04
Pile N.	5
MAXIMUM	1.8124E+04
Pile N.	10

* EFFECTS FOR LATERALLY LOADED PILE *
 * MINIMUM VALUES AND LOCATIONS *

PILE	DISPL. y-Dir	DISPL. z-Dir	MOMENT z-Dir	MOMENT y-Dir	SHEAR y-Dir	SHEAR z-Dir	SOIL REACT y-Dir	SOIL REACT z-Dir	TOTAL STRESS	FLEX. RIG. z-Dir	FLEX. RIG. y-Dir
	M	M	KN- M	KN- M	KN	KN	KN/ M	KN/ M	KN/ M**2	KN- M**2	KN- M**2
1	-2.0971E-05	-7.4827E-03	-1510.5	-1360.3	-162.53	-1235.4	-50.372	-232.69	340.24	7.8279E+06	7.8279E+06
x(M)	12.420	0.0000	0.0000	7.2900	10.800	0.0000	12.420	4.3200	27.000	0.0000	0.0000
2	-2.3542E-05	-7.2861E-03	-1339.7	-1204.3	-149.72	-1034.1	-43.039	-186.12	928.13	7.8279E+06	7.8279E+06
x(M)	12.690	0.0000	0.0000	7.5600	11.340	0.0000	12.960	4.3200	27.000	0.0000	0.0000
3	-2.1825E-05	-7.0896E-03	-1451.3	-1243.7	-158.75	-1107.3	-47.756	-205.22	2127.5	7.8279E+06	7.8279E+06
x(M)	12.420	0.0000	0.0000	7.2900	11.070	0.0000	12.690	4.3200	27.000	0.0000	0.0000
4	-2.0467E-05	-7.4827E-03	-1335.6	-1322.7	-149.33	-1179.2	-45.045	-219.42	2060.3	7.8279E+06	7.8279E+06
x(M)	12.420	0.0000	0.0000	7.2900	11.070	0.0000	12.420	4.3200	27.000	0.0000	0.0000
5	-2.3183E-05	-7.2861E-03	-1169.7	-1166.4	-135.94	-975.25	-37.922	-172.60	840.32	7.8279E+06	7.8279E+06
x(M)	12.960	0.0000	0.0000	7.8300	11.340	0.0000	12.960	4.3200	27.000	0.0000	0.0000
6	-2.1337E-05	-7.0896E-03	-1271.4	-1203.3	-143.89	-1046.3	-42.216	-190.96	452.67	7.8279E+06	7.8279E+06
x(M)	12.690	0.0000	0.0000	7.5600	11.070	0.0000	12.690	4.3200	27.000	0.0000	0.0000
7	-1.8593E-05	-7.4827E-03	-1248.7	-1352.9	-141.75	-1217.0	-43.487	-228.86	3683.6	7.8279E+06	7.8279E+06
x(M)	12.420	0.0000	0.0000	7.2900	10.800	0.0000	12.420	4.3200	27.000	0.0000	0.0000
8	-2.0894E-05	-7.2861E-03	-1099.4	-1196.9	-129.85	-1016.2	-36.976	-182.54	2530.3	7.8279E+06	7.8279E+06
x(M)	12.690	0.0000	0.0000	7.8300	11.340	0.0000	12.960	4.3200	27.000	0.0000	0.0000
9	-1.9401E-05	-7.0896E-03	-1194.8	-1235.0	-137.93	-1087.7	-41.110	-201.14	1310.3	7.8279E+06	7.8279E+06
x(M)	12.420	0.0000	0.0000	7.2900	11.070	0.0000	12.420	4.3200	27.000	0.0000	0.0000
10	-1.5083E-05	-7.4827E-03	-1366.3	-1573.5	-153.10	-1526.4	-51.965	-305.26	4809.7	7.8279E+06	7.8279E+06
x(M)	11.610	0.0000	0.0000	6.7500	10.260	0.0000	11.610	4.3200	27.000	0.0000	0.0000
11	-1.5587E-05	-7.2861E-03	-1284.9	-1456.3	-145.65	-1378.3	-47.821	-270.40	3996.8	7.8279E+06	7.8279E+06
x(M)	11.880	0.0000	0.0000	7.0200	10.530	0.0000	11.880	4.3200	27.000	0.0000	0.0000
12	-1.5189E-05	-7.0896E-03	-1346.9	-1469.6	-150.33	-1413.1	-50.866	-281.01	3000.3	7.8279E+06	7.8279E+06
x(M)	11.610	0.0000	0.0000	6.7500	10.260	0.0000	11.610	4.3200	27.000	0.0000	0.0000
Min.	-2.3542E-05	-7.4827E-03	-1510.5	-1573.5	-162.53	-1526.4	-51.965	-305.26	340.24	7.8279E+06	7.8279E+06
Pile N.	2	1	1	10	1	10	10	10	1	1	1

* MAXIMUM VALUES AND LOCATIONS *

PILE	DISPL. y-Dir	DISPL. z-Dir	MOMENT z-Dir	MOMENT y-Dir	SHEAR y-Dir	SHEAR z-Dir	SOIL REACT y-Dir	SOIL REACT z-Dir	TOTAL STRESS	FLEX. RIG. z-Dir	FLEX. RIG. y-Dir
	M	M	KN- M	KN- M	KN	KN	KN/ M	KN/ M	KN/ M**2	KN- M**2	KN- M**2
1	3.7134E-03	4.5082E-05	665.67	3582.9	562.80	349.49	108.72	108.28	1.2075E+04	7.8279E+06	7.8279E+06
x(M)	0.0000	12.420	7.0200	0.0000	0.0000	11.070	4.3200	0.0000	0.0000	0.0000	0.0000
2	3.7134E-03	4.9118E-05	604.55	3101.3	483.92	313.15	89.554	90.436	1.1124E+04	7.8279E+06	7.8279E+06
x(M)	0.0000	12.960	7.2900	0.0000	0.0000	11.340	4.3200	0.0000	0.0000	0.0000	0.0000
3	3.7134E-03	4.3909E-05	643.14	3213.3	537.18	320.30	101.91	97.061	1.2769E+04	7.8279E+06	7.8279E+06
x(M)	0.0000	12.420	7.0200	0.0000	0.0000	11.070	4.3200	0.0000	0.0000	0.0000	0.0000
4	3.5169E-03	4.6783E-05	611.82	3467.9	499.63	342.65	95.980	103.98	1.3276E+04	7.8279E+06	7.8279E+06
x(M)	0.0000	12.420	7.0200	0.0000	0.0000	11.070	4.3200	0.0000	0.0000	0.0000	0.0000
5	3.5169E-03	5.1845E-05	552.22	2976.0	423.77	302.02	77.735	85.240	1.0491E+04	7.8279E+06	7.8279E+06
x(M)	0.0000	12.960	7.5600	0.0000	0.0000	11.610	4.3200	0.0000	0.0000	0.0000	0.0000
6	3.5169E-03	4.6166E-05	587.71	3086.5	471.88	309.98	88.776	91.541	1.0527E+04	7.8279E+06	7.8279E+06
x(M)	0.0000	12.690	7.2900	0.0000	0.0000	11.340	4.3200	0.0000	0.0000	0.0000	0.0000

APPALTATORE: Consorzio Soci   	ITINERARIO NAPOLI – BARI RADDOPPIO TRATTA APICE – ORSARA I LOTTO FUNZIONALE APICE – HIRPINIA				
PROGETTAZIONE: Mandataria Mandanti   					
PROGETTO ESECUTIVO RELAZIONE DI CALCOLO FONDAZIONI SPALLA A					
COMMESSA IF1N	LOTTO 01 E ZZ	CODIFICA RG	DOCUMENTO MD0000 001	REV. B	FOGLIO 65 di 109

7	3.3203E-03	4.5793E-05	589.65	3553.2	478.51	348.41	93.340	107.21	1.5050E+04	7.8279E+06	7.8279E+06
x(M)	0.0000	12.420	7.0200	0.0000	0.0000	11.070	4.3200	12.690	0.0000	0.0000	0.0000
8	3.3203E-03	5.0108E-05	535.29	3071.4	409.44	311.69	76.637	89.337	1.2376E+04	7.8279E+06	7.8279E+06
x(M)	0.0000	12.960	7.2900	0.0000	0.0000	11.340	4.3200	12.960	0.0000	0.0000	0.0000
9	3.3203E-03	4.4799E-05	569.38	3180.6	455.11	318.64	87.182	95.875	1.1565E+04	7.8279E+06	7.8279E+06
x(M)	0.0000	12.690	7.0200	0.0000	0.0000	11.070	4.3200	12.690	0.0000	0.0000	0.0000
10	3.1238E-03	3.8502E-05	645.32	4194.8	559.54	391.47	115.68	134.37	1.8124E+04	7.8279E+06	7.8279E+06
x(M)	0.0000	11.610	6.4800	0.0000	0.0000	10.530	4.3200	11.880	0.0000	0.0000	0.0000
11	3.1238E-03	3.9407E-05	614.19	3842.5	519.44	366.34	105.53	121.64	1.6225E+04	7.8279E+06	7.8279E+06
x(M)	0.0000	11.880	6.4800	0.0000	0.0000	10.530	4.3200	12.150	0.0000	0.0000	0.0000
12	3.1238E-03	3.6693E-05	637.38	3860.3	551.62	365.14	113.18	124.21	1.5340E+04	7.8279E+06	7.8279E+06
x(M)	0.0000	11.880	6.4800	0.0000	0.0000	10.530	4.3200	11.880	0.0000	0.0000	0.0000
Max.	3.7134E-03	5.1845E-05	665.67	4194.8	562.80	391.47	115.68	134.37	1.8124E+04	7.8279E+06	7.8279E+06
Pile N.	1	5	1	10	1	10	10	10	10	1	1

LOAD CASE : 4
CASE NAME : Load Case
LOAD TYPE : Special, Sp

REDUCTION FACTORS FOR CLOSELY-SPACED PILE GROUPS, COMBINED Y AND Z DIRECTIONS
ESTIMATED USING MOVEMENT IN THE DIRECTION OF PILE CAP DISPLACEMENTS

GROUP NO	P-FACTOR	Y-FACTOR
1	0.8322	1.0000
2	0.7774	1.0000
3	0.8661	1.0000
4	0.5680	1.0000
5	0.4960	1.0000
6	0.6160	1.0000
7	0.5378	1.0000
8	0.4673	1.0000
9	0.5883	1.0000
10	0.5845	1.0000
11	0.5090	1.0000
12	0.6319	1.0000

* TABLE L * COMPUTATION ON PILE CAP

* EQUIVALENT CONCENTRATED LOAD AT ORIGIN *

VERT. LOAD, KN	HOR. LOAD Y, KN	HOR. LOAD Z, KN
40046.0	-5241.50	14056.9
MOMENT X, KN- M	MOMENT Y, KN- M	MOMENT Z, KN- M
2188.00	1.54136E+05	43619.9

* DISPLACEMENT OF GROUPED PILE FOUNDATION AT ORIGIN *

VERTICAL, M	HORIZONTAL Y, M	HORIZONTAL Z, M
1.81227E-03	-2.89831E-03	7.15343E-03
ANGLE ROT. X, RAD	ANGLE ROT. Y, RAD	ANGLE ROT. Z, RAD
8.08327E-06	3.55136E-04	2.04361E-04

THE GLOBAL STRUCTURAL COORDINATE SYSTEM

* PILE TOP DISPLACEMENTS *

PILE GROUP	DISP. X, M	DISP. Y, M	DISP. Z, M	ROT. X, RAD	ROT. Y, RAD	ROT. Z, RAD
*****	*****	*****	*****	*****	*****	*****
1	3.2898E-03	-2.9529E-03	7.1898E-03	8.0833E-06	3.5514E-04	2.0436E-04
2	4.2094E-03	-2.9529E-03	7.1534E-03	8.0833E-06	3.5514E-04	2.0436E-04
3	5.1291E-03	-2.9529E-03	7.1171E-03	8.0833E-06	3.5514E-04	2.0436E-04
4	1.6917E-03	-2.9165E-03	7.1898E-03	8.0833E-06	3.5514E-04	2.0436E-04
5	2.6113E-03	-2.9165E-03	7.1534E-03	8.0833E-06	3.5514E-04	2.0436E-04
6	3.5310E-03	-2.9165E-03	7.1171E-03	8.0833E-06	3.5514E-04	2.0436E-04
7	9.3584E-05	-2.8801E-03	7.1898E-03	8.0833E-06	3.5514E-04	2.0436E-04
8	1.0132E-03	-2.8801E-03	7.1534E-03	8.0833E-06	3.5514E-04	2.0436E-04
9	1.9328E-03	-2.8801E-03	7.1171E-03	8.0833E-06	3.5514E-04	2.0436E-04
10	-1.5045E-03	-2.8437E-03	7.1898E-03	8.0833E-06	3.5514E-04	2.0436E-04
11	-5.8490E-04	-2.8437E-03	7.1534E-03	8.0833E-06	3.5514E-04	2.0436E-04
12	3.3473E-04	-2.8437E-03	7.1171E-03	8.0833E-06	3.5514E-04	2.0436E-04
MINIMUM	-1.5045E-03	-2.9529E-03	7.1171E-03	8.0833E-06	3.5514E-04	2.0436E-04
Pile N.	10	1	3	1	1	1
MAXIMUM	5.1291E-03	-2.8437E-03	7.1898E-03	8.0833E-06	3.5514E-04	2.0436E-04

APPALTATORE: Consorzio HirpiniaAV Soci salini impregio ASTALDI		ITINERARIO NAPOLI – BARI RADDOPPIO TRATTA APICE – ORSARA I LOTTO FUNZIONALE APICE – HIRPINIA				
PROGETTAZIONE: Mandatario ROKSOJL Mandanti NETENGINEERING Alpina						
PROGETTO ESECUTIVO RELAZIONE DI CALCOLO FONDAZIONI SPALLA A						
COMMESSA	LOTTO	CODIFICA	DOCUMENTO	REV.	FOGLIO	
IF1N	01 E ZZ	RG	MD0000 001	B	66 di 109	

Pile N. 3 10 1 1 1 1

* PILE TOP REACTIONS *

PILE GROUP	FOR. X, KN	FOR. Y, KN	FOR. Z, KN	MOM X, KN- M	MOM Y, KN- M	MOM Z, KN- M
1	6318.3	-548.58	1438.9	2.1463	-3927.3	-1402.1
2	7481.6	-523.29	1366.2	2.1463	-3773.4	-1352.4
3	8644.9	-565.88	1465.4	2.1463	-3966.0	-1438.1
4	3306.6	-412.48	1108.2	2.1463	-3236.4	-1112.0
5	5052.4	-374.76	1004.1	2.1463	-3005.6	-1032.5
6	6623.4	-437.77	1159.8	2.1463	-3335.8	-1167.8
7	190.96	-391.45	1070.3	2.1463	-3148.9	-1056.7
8	2018.5	-354.37	966.58	2.1463	-2917.4	-978.03
9	3764.4	-417.88	1126.4	2.1463	-3259.4	-1115.4
10	-2878.5	-409.71	1136.5	2.1463	-3285.0	-1084.8
11	-1159.5	-371.53	1028.0	2.1463	-3046.4	-1004.9
12	683.03	-433.79	1186.5	2.1463	-3380.9	-1137.8
MINIMUM	-2878.5	-565.88	966.58	2.1463	-3966.0	-1438.1
Pile N.	10	3	8	1	3	3
MAXIMUM	8644.9	-354.37	1465.4	2.1463	-2917.4	-978.03
Pile N.	3	8	3	1	8	8

THE PILE COORDINATE SYSTEM (LOCAL AXES)

* PILE TOP DISPLACEMENTS *

PILE GROUP	DISP. x, M	DISP. y, M	DISP. z, M	ROT. x, RAD	ROT. y, RAD	ROT. z, RAD
1	3.2898E-03	-2.9529E-03	7.1898E-03	8.0833E-06	3.5514E-04	2.0436E-04
2	4.2094E-03	-2.9529E-03	7.1534E-03	8.0833E-06	3.5514E-04	2.0436E-04
3	5.1291E-03	-2.9529E-03	7.1171E-03	8.0833E-06	3.5514E-04	2.0436E-04
4	1.6917E-03	-2.9165E-03	7.1898E-03	8.0833E-06	3.5514E-04	2.0436E-04
5	2.6113E-03	-2.9165E-03	7.1534E-03	8.0833E-06	3.5514E-04	2.0436E-04
6	3.5310E-03	-2.9165E-03	7.1171E-03	8.0833E-06	3.5514E-04	2.0436E-04
7	9.3584E-05	-2.8801E-03	7.1898E-03	8.0833E-06	3.5514E-04	2.0436E-04
8	1.0132E-03	-2.8801E-03	7.1534E-03	8.0833E-06	3.5514E-04	2.0436E-04
9	1.9328E-03	-2.8801E-03	7.1171E-03	8.0833E-06	3.5514E-04	2.0436E-04
10	-1.5045E-03	-2.8437E-03	7.1898E-03	8.0833E-06	3.5514E-04	2.0436E-04
11	-5.8490E-04	-2.8437E-03	7.1534E-03	8.0833E-06	3.5514E-04	2.0436E-04
12	3.3473E-04	-2.8437E-03	7.1171E-03	8.0833E-06	3.5514E-04	2.0436E-04
MINIMUM	-1.5045E-03	-2.9529E-03	7.1171E-03	8.0833E-06	3.5514E-04	2.0436E-04
Pile N.	10	1	3	1	1	1
MAXIMUM	5.1291E-03	-2.8437E-03	7.1898E-03	8.0833E-06	3.5514E-04	2.0436E-04
Pile N.	3	10	1	1	1	1

* PILE TOP REACTIONS *

PILE GROUP	AXIAL, KN	LAT. y, KN	LAT. z, KN	MOM x, KN- M	MOM y, KN- M	MOM z, KN- M
1	6318.3	-548.58	1438.9	2.1463	-3927.3	-1402.1
2	7481.6	-523.29	1366.2	2.1463	-3773.4	-1352.4
3	8644.9	-565.88	1465.4	2.1463	-3966.0	-1438.1
4	3306.6	-412.48	1108.2	2.1463	-3236.4	-1112.0
5	5052.4	-374.76	1004.1	2.1463	-3005.6	-1032.5
6	6623.4	-437.77	1159.8	2.1463	-3335.8	-1167.8
7	190.96	-391.45	1070.3	2.1463	-3148.9	-1056.7
8	2018.5	-354.37	966.58	2.1463	-2917.4	-978.03
9	3764.4	-417.88	1126.4	2.1463	-3259.4	-1115.4
10	-2878.5	-409.71	1136.5	2.1463	-3285.0	-1084.8
11	-1159.5	-371.53	1028.0	2.1463	-3046.4	-1004.9
12	683.03	-433.79	1186.5	2.1463	-3380.9	-1137.8
MINIMUM	-2878.5	-565.88	966.58	2.1463	-3966.0	-1438.1
Pile N.	10	3	8	1	3	3
MAXIMUM	8644.9	-354.37	1465.4	2.1463	-2917.4	-978.03
Pile N.	3	8	3	1	8	8

PILE GROUP STRESS, KN/ M**2

1	1.6161E+04
2	1.6331E+04
3	1.7624E+04
4	1.2199E+04
5	1.2450E+04
6	1.4415E+04
7	1.0132E+04
8	1.0429E+04
9	1.2527E+04
10	1.2070E+04
11	1.0338E+04
12	1.1153E+04
MINIMUM	1.0132E+04

APPALTATORE:

Consorzio

Soci



ITINERARIO NAPOLI – BARI

PROGETTAZIONE:

Mandatario

Mandanti



RADDOPPIO TRATTA APICE – ORSARA
I LOTTO FUNZIONALE APICE – HIRPINIA

PROGETTO ESECUTIVO

RELAZIONE DI CALCOLO FONDAZIONI SPALLA A

COMMESSA IF1N	LOTTO 01 E ZZ	CODIFICA RG	DOCUMENTO MD0000 001	REV. B	FOGLIO 67 di 109
------------------	------------------	----------------	-------------------------	-----------	---------------------

Pile N. 7
MAXIMUM 1.7624E+04
Pile N. 3

* EFFECTS FOR LATERALLY LOADED PILE *

* MINIMUM VALUES AND LOCATIONS *

PILE	DISPL. y-DIR M	DISPL. z-DIR M	MOMENT z-DIR KN- M	MOMENT y-DIR KN- M	SHEAR y-DIR KN	SHEAR z-DIR KN	SOIL REACT y-DIR KN/ M	SOIL REACT z-DIR KN/ M	TOTAL STRESS KN/ M**2	FLEX. RIG. z-DIR KN- M**2	FLEX. RIG. y-DIR KN- M**2
*****	*****	*****	*****	*****	*****	*****	*****	*****	*****	*****	*****
1	-2.9529E-03	-3.7016E-05	-606.95	-3927.3	-548.73	-371.17	-111.39	-126.57	3575.4	7.8279E+06	7.8279E+06
x(M)	0.0000	11.880	6.4800	0.0000	0.0000	10.530	4.3200	11.880	27.000	0.0000	0.0000
2	-2.9529E-03	-3.8148E-05	-588.87	-3773.4	-523.46	-361.16	-105.20	-120.21	4233.7	7.8279E+06	7.8279E+06
x(M)	0.0000	11.880	6.7500	0.0000	0.0000	10.530	4.3200	12.150	27.000	0.0000	0.0000
3	-2.9529E-03	-3.6358E-05	-620.86	-3966.0	-566.10	-373.33	-115.78	-129.17	4892.0	7.8279E+06	7.8279E+06
x(M)	0.0000	11.610	6.4800	0.0000	0.0000	10.260	4.3200	11.880	27.000	0.0000	0.0000
4	-2.9165E-03	-4.5148E-05	-502.88	-3236.4	-412.55	-323.89	-78.476	-97.635	1871.1	7.8279E+06	7.8279E+06
x(M)	0.0000	12.690	7.0200	0.0000	0.0000	11.070	4.3200	12.690	27.000	0.0000	0.0000
5	-2.9165E-03	-4.8332E-05	-475.17	-3005.6	-374.85	-306.28	-69.635	-88.318	2859.1	7.8279E+06	7.8279E+06
x(M)	0.0000	12.960	7.2900	0.0000	0.0000	11.340	4.3200	12.960	27.000	0.0000	0.0000
6	-2.9165E-03	-4.2876E-05	-523.60	-3335.8	-437.91	-329.82	-84.710	-102.38	3748.1	7.8279E+06	7.8279E+06
x(M)	0.0000	12.420	7.0200	0.0000	0.0000	11.070	4.3200	12.420	27.000	0.0000	0.0000
7	-2.8801E-03	-4.6531E-05	-484.13	-3148.9	-391.46	-315.26	-73.685	-93.504	108.06	7.8279E+06	7.8279E+06
x(M)	0.0000	12.690	7.2900	0.0000	0.0000	11.340	4.3200	12.690	27.000	0.0000	0.0000
8	-2.8801E-03	-5.0172E-05	-456.58	-2917.4	-354.41	-298.74	-65.057	-84.513	1142.3	7.8279E+06	7.8279E+06
x(M)	0.0000	12.960	7.2900	0.0000	0.0000	11.340	4.3200	13.230	27.000	0.0000	0.0000
9	-2.8801E-03	-4.3743E-05	-505.89	-3259.4	-417.95	-324.81	-80.171	-99.128	2130.2	7.8279E+06	7.8279E+06
x(M)	0.0000	12.420	7.0200	0.0000	0.0000	11.070	4.3200	12.690	27.000	0.0000	0.0000
10	-2.8437E-03	-4.4172E-05	-495.43	-3285.0	-409.65	-326.34	-78.254	-99.365	1628.9	7.8279E+06	7.8279E+06
x(M)	0.0000	12.420	7.0200	0.0000	0.0000	11.070	4.3200	12.690	27.000	0.0000	0.0000
11	-2.8437E-03	-4.7370E-05	-467.11	-3046.4	-371.51	-308.22	-69.280	-89.779	656.17	7.8279E+06	7.8279E+06
x(M)	0.0000	12.690	7.2900	0.0000	0.0000	11.340	4.3200	12.960	27.000	0.0000	0.0000
12	-2.8437E-03	-4.1975E-05	-514.91	-3380.9	-433.81	-331.49	-84.218	-104.22	386.51	7.8279E+06	7.8279E+06
x(M)	0.0000	12.420	7.0200	0.0000	0.0000	11.070	4.3200	12.420	27.000	0.0000	0.0000
Min.	-2.9529E-03	-5.0172E-05	-620.86	-3966.0	-566.10	-373.33	-115.78	-129.17	108.06	7.8279E+06	7.8279E+06
Pile N.	1	8	3	3	3	3	3	3	7	1	1

* MAXIMUM VALUES AND LOCATIONS *

PILE	DISPL. y-DIR M	DISPL. z-DIR M	MOMENT z-DIR KN- M	MOMENT y-DIR KN- M	SHEAR y-DIR KN	SHEAR z-DIR KN	SOIL REACT y-DIR KN/ M	SOIL REACT z-DIR KN/ M	TOTAL STRESS KN/ M**2	FLEX. RIG. z-DIR KN- M**2	FLEX. RIG. y-DIR KN- M**2
*****	*****	*****	*****	*****	*****	*****	*****	*****	*****	*****	*****
1	1.4621E-05	7.1898E-03	1402.1	1495.4	145.26	1439.3	49.411	286.72	1.6161E+04	7.8279E+06	7.8279E+06
x(M)	11.610	0.0000	0.0000	6.7500	10.260	0.0000	11.610	4.3200	0.0000	0.0000	0.0000
2	1.5011E-05	7.1534E-03	1352.4	1442.4	142.45	1366.7	47.264	269.30	1.6331E+04	7.8279E+06	7.8279E+06
x(M)	11.880	0.0000	0.0000	6.7500	10.530	0.0000	11.880	4.3200	0.0000	0.0000	0.0000
3	1.4535E-05	7.1171E-03	1438.1	1512.8	150.09	1466.0	51.430	294.57	1.7624E+04	7.8279E+06	7.8279E+06
x(M)	11.610	0.0000	0.0000	6.7500	10.260	0.0000	11.610	4.3200	0.0000	0.0000	0.0000
4	1.7261E-05	7.1898E-03	1112.0	1256.6	123.63	1108.4	36.962	205.31	1.2199E+04	7.8279E+06	7.8279E+06
x(M)	12.420	0.0000	0.0000	7.2900	11.070	0.0000	12.690	4.3200	0.0000	0.0000	0.0000
5	1.8537E-05	7.1534E-03	1032.5	1182.7	116.91	1004.3	33.564	181.23	1.2450E+04	7.8279E+06	7.8279E+06
x(M)	12.690	0.0000	0.0000	7.5600	11.340	0.0000	12.960	4.3200	0.0000	0.0000	0.0000
6	1.6518E-05	7.1171E-03	1167.8	1293.7	127.65	1160.2	39.442	219.01	1.4415E+04	7.8279E+06	7.8279E+06
x(M)	12.420	0.0000	0.0000	7.2900	10.800	0.0000	12.420	4.3200	0.0000	0.0000	0.0000
7	1.7403E-05	7.1898E-03	1056.7	1226.7	118.83	1070.4	34.971	195.76	1.0132E+04	7.8279E+06	7.8279E+06
x(M)	12.690	0.0000	0.0000	7.5600	11.070	0.0000	12.690	4.3200	0.0000	0.0000	0.0000
8	1.8832E-05	7.1534E-03	978.03	1153.2	112.76	966.68	31.698	171.94	1.0429E+04	7.8279E+06	7.8279E+06
x(M)	12.960	0.0000	0.0000	7.8300	11.340	0.0000	12.960	4.3200	0.0000	0.0000	0.0000
9	1.6653E-05	7.1171E-03	1115.4	1266.7	123.20	1126.6	37.557	210.47	1.2527E+04	7.8279E+06	7.8279E+06
x(M)	12.420	0.0000	0.0000	7.2900	11.070	0.0000	12.420	4.3200	0.0000	0.0000	0.0000
10	1.6385E-05	7.1898E-03	1084.8	1270.4	120.62	1136.3	36.560	211.04	1.2070E+04	7.8279E+06	7.8279E+06
x(M)	12.420	0.0000	0.0000	7.2900	11.070	0.0000	12.420	4.3200	0.0000	0.0000	0.0000
11	1.7617E-05	7.1534E-03	1004.9	1193.4	113.89	1027.9	33.107	185.87	1.0338E+04	7.8279E+06	7.8279E+06
x(M)	12.690	0.0000	0.0000	7.5600	11.340	0.0000	12.690	4.3200	0.0000	0.0000	0.0000
12	1.5731E-05	7.1171E-03	1137.8	1305.8	125.20	1186.6	38.862	224.45	1.1153E+04	7.8279E+06	7.8279E+06
x(M)	12.150	0.0000	0.0000	7.2900	10.800	0.0000	12.420	4.3200	0.0000	0.0000	0.0000
Max.	1.8832E-05	7.1898E-03	1438.1	1512.8	150.09	1466.0	51.430	294.57	1.7624E+04	7.8279E+06	7.8279E+06
Pile N.	8	1	3	3	3	3	3	3	3	1	1

LOAD CASE : 5
CASE NAME : Load Case
LOAD TYPE : Special, Sp

REDUCTION FACTORS FOR CLOSELY-SPACED PILE GROUPS, COMBINED Y AND Z DIRECTIONS
ESTIMATED USING MOVEMENT IN THE DIRECTION OF PILE CAP DISPLACEMENTS

GROUP NO	P-FACTOR	Y-FACTOR
1	0.6833	1.0000
2	0.6568	1.0000
3	0.8661	1.0000

APPALTATORE: Consorzio Soci   	ITINERARIO NAPOLI – BARI RADDOPPIO TRATTA APICE – ORSARA I LOTTO FUNZIONALE APICE – HIRPINIA				
PROGETTAZIONE: Mandataria Mandanti   					
PROGETTO ESECUTIVO RELAZIONE DI CALCOLO FONDAZIONI SPALLA A					
COMMESSA IF1N	LOTTO 01 E ZZ	CODIFICA RG	DOCUMENTO MD0000 001	REV. B	FOGLIO 68 di 109

4	0.5226	1.0000
5	0.4954	1.0000
6	0.7433	1.0000
7	0.5110	1.0000
8	0.4853	1.0000
9	0.7352	1.0000
10	0.5845	1.0000
11	0.5551	1.0000
12	0.7905	1.0000

* TABLE L * COMPUTATION ON PILE CAP

* EQUIVALENT CONCENTRATED LOAD AT ORIGIN *

VERT. LOAD, KN	HOR. LOAD Y, KN	HOR. LOAD Z, KN
50606.0	-5831.10	4217.40
MOMENT X, KN- M	MOMENT Y, KN- M	MOMENT Z, KN- M
656.000	46544.3	48629.3

* DISPLACEMENT OF GROUPED PILE FOUNDATION AT ORIGIN *

VERTICAL, M	HORIZONTAL Y, M	HORIZONTAL Z, M
2.18988E-03	-2.20855E-03	1.46899E-03
ANGLE ROT. X, RAD	ANGLE ROT. Y, RAD	ANGLE ROT. Z, RAD
8.31463E-06	1.02498E-04	2.05767E-04

THE GLOBAL STRUCTURAL COORDINATE SYSTEM

* PILE TOP DISPLACEMENTS *

PILE GROUP	DISP. X, M	DISP. Y, M	DISP. Z, M	ROT. X, RAD	ROT. Y, RAD	ROT. Z, RAD
*****	*****	*****	*****	*****	*****	*****
1	1.9558E-03	-2.2647E-03	1.5064E-03	8.3146E-06	1.0250E-04	2.0577E-04
2	2.8818E-03	-2.2647E-03	1.4690E-03	8.3146E-06	1.0250E-04	2.0577E-04
3	3.8077E-03	-2.2647E-03	1.4316E-03	8.3146E-06	1.0250E-04	2.0577E-04
4	1.4946E-03	-2.2273E-03	1.5064E-03	8.3146E-06	1.0250E-04	2.0577E-04
5	2.4205E-03	-2.2273E-03	1.4690E-03	8.3146E-06	1.0250E-04	2.0577E-04
6	3.3464E-03	-2.2273E-03	1.4316E-03	8.3146E-06	1.0250E-04	2.0577E-04
7	1.0333E-03	-2.1898E-03	1.5064E-03	8.3146E-06	1.0250E-04	2.0577E-04
8	1.9593E-03	-2.1898E-03	1.4690E-03	8.3146E-06	1.0250E-04	2.0577E-04
9	2.8852E-03	-2.1898E-03	1.4316E-03	8.3146E-06	1.0250E-04	2.0577E-04
10	5.7207E-04	-2.1524E-03	1.5064E-03	8.3146E-06	1.0250E-04	2.0577E-04
11	1.4980E-03	-2.1524E-03	1.4690E-03	8.3146E-06	1.0250E-04	2.0577E-04
12	2.4240E-03	-2.1524E-03	1.4316E-03	8.3146E-06	1.0250E-04	2.0577E-04
MINIMUM	5.7207E-04	-2.2647E-03	1.4316E-03	8.3146E-06	1.0250E-04	2.0577E-04
Pile N.	10	1	3	1	1	1
MAXIMUM	3.8077E-03	-2.1524E-03	1.5064E-03	8.3146E-06	1.0250E-04	2.0577E-04
Pile N.	3	10	1	1	1	1

* PILE TOP REACTIONS *

PILE GROUP	FOR. X, KN	FOR. Y, KN	FOR. Z, KN	MOM X, KN- M	MOM Y, KN- M	MOM Z, KN- M
*****	*****	*****	*****	*****	*****	*****
1	3807.9	-525.57	379.69	2.2077	-910.95	-1163.9
2	5565.7	-512.32	359.04	2.2077	-862.69	-1141.4
3	6973.4	-623.11	420.64	2.2077	-959.78	-1335.7
4	2932.3	-427.19	317.70	2.2077	-795.45	-971.79
5	4690.1	-412.18	297.38	2.2077	-746.87	-944.62
6	6390.0	-550.54	381.03	2.2077	-890.71	-1197.8
7	2056.7	-412.85	314.44	2.2077	-788.88	-933.54
8	3814.5	-398.85	294.71	2.2077	-741.39	-908.22
9	5572.3	-536.81	380.12	2.2077	-888.84	-1160.9
10	1167.3	-445.99	346.46	2.2077	-849.02	-983.61
11	2938.9	-430.95	324.88	2.2077	-798.57	-957.17
12	4696.7	-554.72	401.31	2.2077	-925.72	-1178.7
MINIMUM	1167.3	-623.11	294.71	2.2077	-959.78	-1335.7
Pile N.	10	3	8	1	3	3
MAXIMUM	6973.4	-398.85	420.64	2.2077	-741.39	-908.22
Pile N.	3	8	3	1	8	8

THE PILE COORDINATE SYSTEM (LOCAL AXES)

* PILE TOP DISPLACEMENTS *

APPALTATORE:

Consorzio

Soci



ITINERARIO NAPOLI – BARI

PROGETTAZIONE:

Mandatario

Mandanti



RADDOPPIO TRATTA APICE – ORSARA
I LOTTO FUNZIONALE APICE – HIRPINIA

PROGETTO ESECUTIVO

RELAZIONE DI CALCOLO FONDAZIONI SPALLA A

COMMESSA	LOTTO	CODIFICA	DOCUMENTO	REV.	FOGLIO
IF1N	01 E ZZ	RG	MD0000 001	B	69 di 109

PILE GROUP	DISP. x, M	DISP. y, M	DISP. z, M	ROT. x,RAD	ROT. y,RAD	ROT. z,RAD
*****	*****	*****	*****	*****	*****	*****
1	1.9558E-03	-2.2647E-03	1.5064E-03	8.3146E-06	1.0250E-04	2.0577E-04
2	2.8818E-03	-2.2647E-03	1.4690E-03	8.3146E-06	1.0250E-04	2.0577E-04
3	3.8077E-03	-2.2647E-03	1.4316E-03	8.3146E-06	1.0250E-04	2.0577E-04
4	1.4946E-03	-2.2273E-03	1.5064E-03	8.3146E-06	1.0250E-04	2.0577E-04
5	2.4205E-03	-2.2273E-03	1.4690E-03	8.3146E-06	1.0250E-04	2.0577E-04
6	3.3464E-03	-2.2273E-03	1.4316E-03	8.3146E-06	1.0250E-04	2.0577E-04
7	1.0333E-03	-2.1898E-03	1.5064E-03	8.3146E-06	1.0250E-04	2.0577E-04
8	1.9593E-03	-2.1898E-03	1.4690E-03	8.3146E-06	1.0250E-04	2.0577E-04
9	2.8852E-03	-2.1898E-03	1.4316E-03	8.3146E-06	1.0250E-04	2.0577E-04
10	5.7207E-04	-2.1524E-03	1.5064E-03	8.3146E-06	1.0250E-04	2.0577E-04
11	1.4980E-03	-2.1524E-03	1.4690E-03	8.3146E-06	1.0250E-04	2.0577E-04
12	2.4240E-03	-2.1524E-03	1.4316E-03	8.3146E-06	1.0250E-04	2.0577E-04
MINIMUM	5.7207E-04	-2.2647E-03	1.4316E-03	8.3146E-06	1.0250E-04	2.0577E-04
Pile N.	10	1	3	1	1	1
MAXIMUM	3.8077E-03	-2.1524E-03	1.5064E-03	8.3146E-06	1.0250E-04	2.0577E-04
Pile N.	3	10	1	1	1	1

* PILE TOP REACTIONS *

PILE GROUP	AXIAL, KN	LAT. y, KN	LAT. z, KN	MOM x, KN- M	MOM y, KN- M	MOM z, KN- M
*****	*****	*****	*****	*****	*****	*****
1	3807.9	-525.57	379.69	2.2077	-910.95	-1163.9
2	5565.7	-512.32	359.04	2.2077	-862.69	-1141.4
3	6973.4	-623.11	420.64	2.2077	-959.78	-1335.7
4	2932.3	-427.19	317.70	2.2077	-795.45	-971.79
5	4690.1	-412.18	297.38	2.2077	-746.87	-944.62
6	6390.0	-550.54	381.03	2.2077	-890.71	-1197.8
7	2056.7	-412.85	314.44	2.2077	-788.88	-933.54
8	3814.5	-398.85	294.71	2.2077	-741.39	-908.22
9	5572.3	-536.81	380.12	2.2077	-888.84	-1160.9
10	1167.3	-445.99	346.46	2.2077	-849.02	-983.61
11	2938.9	-430.95	324.88	2.2077	-798.57	-957.17
12	4696.7	-554.72	401.31	2.2077	-925.72	-1178.7
MINIMUM	1167.3	-623.11	294.71	2.2077	-959.78	-1335.7
Pile N.	10	3	8	1	3	3
MAXIMUM	6973.4	-398.85	420.64	2.2077	-741.39	-908.22
Pile N.	3	8	3	1	8	8

PILE GROUP STRESS, KN/ M**2

PILE GROUP	STRESS, KN/ M**2
*****	*****
1	6615.5
2	7467.7
3	8910.3
4	5449.5
5	6288.4
6	8120.9
7	4852.6
8	5697.0
9	7565.9
10	4582.1
11	5425.2
12	7181.1
MINIMUM	4582.1
Pile N.	10
MAXIMUM	8910.3
Pile N.	3

* EFFECTS FOR LATERALLY LOADED PILE *

* MINIMUM VALUES AND LOCATIONS *

PILE	DISPL. y-DIR	DISPL. z-DIR	MOMENT z-DIR	MOMENT y-DIR	SHEAR y-DIR	SHEAR z-DIR	SOIL REACT y-DIR	SOIL REACT z-DIR	TOTAL STRESS	FLEX. RIG. z-DIR	FLEX. RIG. y-DIR
*****	*****	*****	*****	*****	*****	*****	*****	*****	*****	*****	*****
1	-2.2647E-03	-1.2482E-05	-575.00	-910.95	-525.65	-99.902	-113.09	-43.463	2154.8	7.8279E+06	7.8279E+06
x (M)	0.0000	10.260	5.9400	0.0000	0.0000	9.1800	4.3200	10.800	27.000	0.0000	0.0000
2	-2.2647E-03	-1.1998E-05	-566.93	-862.69	-512.43	-95.687	-109.87	-40.572	3149.6	7.8279E+06	7.8279E+06
x (M)	0.0000	10.530	5.9400	0.0000	0.0000	9.1800	4.3200	11.070	27.000	0.0000	0.0000
3	-2.2647E-03	-1.4558E-05	-638.61	-959.78	-623.27	-106.74	-138.39	-57.367	3946.2	7.8279E+06	7.8279E+06
x (M)	0.0000	9.7200	5.6700	0.0000	0.0000	8.6400	4.0500	10.260	27.000	0.0000	0.0000
4	-2.2273E-03	-1.0833E-05	-505.01	-795.45	-427.24	-87.202	-89.033	-32.366	1659.4	7.8279E+06	7.8279E+06
x (M)	0.0000	11.070	6.2100	0.0000	0.0000	9.7200	4.3200	11.610	27.000	0.0000	0.0000
5	-2.2273E-03	-1.0416E-05	-494.83	-746.87	-412.26	-82.632	-85.438	-30.247	2654.1	7.8279E+06	7.8279E+06
x (M)	0.0000	11.070	6.2100	0.0000	0.0000	9.7200	4.3200	11.610	27.000	0.0000	0.0000
6	-2.2273E-03	-1.2930E-05	-589.49	-890.71	-550.67	-99.353	-120.20	-47.044	3616.0	7.8279E+06	7.8279E+06
x (M)	0.0000	10.260	5.9400	0.0000	0.0000	8.9100	4.3200	10.530	27.000	0.0000	0.0000
7	-2.1898E-03	-1.0778E-05	-492.72	-788.88	-412.89	-86.343	-85.997	-31.895	1163.9	7.8279E+06	7.8279E+06
x (M)	0.0000	11.070	6.2100	0.0000	0.0000	9.7200	4.3200	11.610	27.000	0.0000	0.0000
8	-2.1898E-03	-1.0357E-05	-483.20	-741.39	-398.91	-81.866	-82.652	-29.812	2158.6	7.8279E+06	7.8279E+06
x (M)	0.0000	11.070	6.2100	0.0000	0.0000	9.7200	4.3200	11.610	27.000	0.0000	0.0000
9	-2.1898E-03	-1.2905E-05	-578.17	-888.84	-536.92	-99.071	-117.29	-46.785	3153.3	7.8279E+06	7.8279E+06
x (M)	0.0000	10.260	5.6700	0.0000	0.0000	8.9100	4.3200	10.530	27.000	0.0000	0.0000

APPALTATORE: Consorzio Soci   		ITINERARIO NAPOLI – BARI RADDOPPIO TRATTA APICE – ORSARA I LOTTO FUNZIONALE APICE – HIRPINIA				
PROGETTAZIONE: Mandataria Mandanti   						
PROGETTO ESECUTIVO RELAZIONE DI CALCOLO FONDAZIONI SPALLA A						
	COMMESSA IF1N	LOTTO 01 E ZZ	CODIFICA RG	DOCUMENTO MD0000 001	REV. B	FOGLIO 70 di 109

10	-2.1524E-03	-1.1471E-05	-513.90	-849.02	-446.01	-92.941	-94.751	-36.923	660.58	7.8279E+06	7.8279E+06
x(M)	0.0000	10.800	5.9400	0.0000	0.0000	9.4500	4.3200	11.340	27.000	0.0000	0.0000
11	-2.1524E-03	-1.0997E-05	-503.82	-798.57	-431.00	-88.335	-91.115	-34.369	1663.1	7.8279E+06	7.8279E+06
x(M)	0.0000	10.800	6.2100	0.0000	0.0000	9.4500	4.3200	11.340	27.000	0.0000	0.0000
12	-2.1524E-03	-1.3804E-05	-587.67	-925.72	-554.82	-102.95	-122.53	-51.996	2657.8	7.8279E+06	7.8279E+06
x(M)	0.0000	9.9900	5.6700	0.0000	0.0000	8.6400	4.0500	10.260	27.000	0.0000	0.0000
Min.	-2.2647E-03	-1.4558E-05	-638.61	-959.78	-623.27	-106.74	-138.39	-57.367	660.58	7.8279E+06	7.8279E+06
Pile N.	1	3	3	3	3	3	3	3	10	1	1

* MAXIMUM VALUES AND LOCATIONS *

PILE	DISPL. y-DIR M	DISPL. z-DIR M	MOMENT z-DIR KN- M	MOMENT y-DIR KN- M	SHEAR y-DIR KN	SHEAR z-DIR KN	SOIL REACT y-DIR KN/ M	SOIL REACT z-DIR KN/ M	TOTAL STRESS KN/ M**2	FLEX. RIG. z-DIR KN- M**2	FLEX. RIG. y-DIR KN- M**2
*****	*****	*****	*****	*****	*****	*****	*****	*****	*****	*****	*****
1	1.9173E-05	1.5064E-03	1163.9	387.75	145.20	379.75	64.259	80.301	6615.5	7.8279E+06	7.8279E+06
x(M)	10.260	0.0000	0.0000	6.2100	8.9100	0.0000	10.800	4.3200	0.0000	0.0000	0.0000
2	1.8754E-05	1.4690E-03	1141.4	372.46	142.74	359.13	61.754	75.724	7467.7	7.8279E+06	7.8279E+06
x(M)	10.260	0.0000	0.0000	6.2100	8.9100	0.0000	10.800	4.3200	0.0000	0.0000	0.0000
3	2.3441E-05	1.4316E-03	1335.7	407.89	164.75	420.75	89.883	92.170	8910.3	7.8279E+06	7.8279E+06
x(M)	9.7200	0.0000	0.0000	5.9400	8.3700	0.0000	10.260	4.3200	0.0000	0.0000	0.0000
4	1.6009E-05	1.5064E-03	971.79	346.55	124.17	317.74	46.364	64.651	5449.5	7.8279E+06	7.8279E+06
x(M)	10.800	0.0000	0.0000	6.4800	9.4500	0.0000	11.340	4.3200	0.0000	0.0000	0.0000
5	1.5778E-05	1.4690E-03	944.62	330.74	121.00	297.44	44.140	60.220	6288.4	7.8279E+06	7.8279E+06
x(M)	11.070	0.0000	0.0000	6.4800	9.7200	0.0000	11.610	4.3200	0.0000	0.0000	0.0000
6	2.0584E-05	1.4316E-03	1197.8	384.16	150.04	381.13	72.540	82.002	8120.9	7.8279E+06	7.8279E+06
x(M)	9.9900	0.0000	0.0000	5.9400	8.6400	0.0000	10.260	4.3200	0.0000	0.0000	0.0000
7	1.5603E-05	1.5064E-03	933.54	344.13	120.57	314.47	44.689	63.823	4852.6	7.8279E+06	7.8279E+06
x(M)	10.800	0.0000	0.0000	6.4800	9.4500	0.0000	11.340	4.3200	0.0000	0.0000	0.0000
8	1.5459E-05	1.4690E-03	908.22	328.68	117.68	294.76	42.702	59.541	5697.0	7.8279E+06	7.8279E+06
x(M)	11.070	0.0000	0.0000	6.4800	9.7200	0.0000	11.610	4.3200	0.0000	0.0000	0.0000
9	2.0210E-05	1.4316E-03	1160.9	383.44	146.76	380.20	70.902	81.764	7565.9	7.8279E+06	7.8279E+06
x(M)	9.9900	0.0000	0.0000	5.9400	8.6400	0.0000	10.260	4.3200	0.0000	0.0000	0.0000
10	1.6633E-05	1.5064E-03	983.61	365.58	127.34	346.48	51.399	71.843	4582.1	7.8279E+06	7.8279E+06
x(M)	10.530	0.0000	0.0000	6.2100	9.1800	0.0000	11.070	4.3200	0.0000	0.0000	0.0000
11	1.6202E-05	1.4690E-03	957.17	349.05	124.28	324.92	48.765	67.062	5425.2	7.8279E+06	7.8279E+06
x(M)	10.800	0.0000	0.0000	6.2100	9.4500	0.0000	11.070	4.3200	0.0000	0.0000	0.0000
12	2.1046E-05	1.4316E-03	1178.7	396.34	149.52	401.39	77.864	87.203	7181.1	7.8279E+06	7.8279E+06
x(M)	9.9900	0.0000	0.0000	5.9400	8.6400	0.0000	10.260	4.3200	0.0000	0.0000	0.0000
Max.	2.3441E-05	1.5064E-03	1335.7	407.89	164.75	420.75	89.883	92.170	8910.3	7.8279E+06	7.8279E+06
Pile N.	3	1	3	3	3	3	3	3	3	1	1

LOAD CASE : 6
CASE NAME : Load Case
LOAD TYPE : Special, Sp

REDUCTION FACTORS FOR CLOSELY-SPACED PILE GROUPS, COMBINED Y AND Z DIRECTIONS
ESTIMATED USING MOVEMENT IN THE DIRECTION OF PILE CAP DISPLACEMENTS

GROUP NO	P-FACTOR	Y-FACTOR
1	0.7975	1.0000
2	0.5573	1.0000
3	0.5845	1.0000
4	0.7417	1.0000
5	0.4862	1.0000
6	0.5097	1.0000
7	0.7490	1.0000
8	0.4954	1.0000
9	0.5202	1.0000
10	0.8661	1.0000
11	0.6503	1.0000
12	0.6751	1.0000

* TABLE L * COMPUTATION ON PILE CAP

* EQUIVALENT CONCENTRATED LOAD AT ORIGIN *

VERT. LOAD, KN	HOR. LOAD Y, KN	HOR. LOAD Z, KN
20964.0	6066.50	-4217.40
MOMENT X, KN- M	MOMENT Y, KN- M	MOMENT Z, KN- M
-656.000	-46234.1	-56934.3

* DISPLACEMENT OF GROUPED PILE FOUNDATION AT ORIGIN *

VERTICAL, M	HORIZONTAL Y, M	HORIZONTAL Z, M
8.88827E-04	2.34504E-03	-1.46040E-03

APPALTATORE:

Consorzio

Soci



ITINERARIO NAPOLI – BARI

RADDOPPIO TRATTA APICE – ORSARA
I LOTTO FUNZIONALE APICE – HIRPINIA

PROGETTAZIONE:

Mandataria

Mandanti



PROGETTO ESECUTIVO

RELAZIONE DI CALCOLO FONDAZIONI SPALLA A

COMMESSA
IF1N

LOTTO
01 E ZZ

CODIFICA
RG

DOCUMENTO
MD0000 001

REV.
B

FOGLIO
71 di 109

ANGLE ROT. X,RAD ANGLE ROT. Y,RAD ANGLE ROT. Z,RAD
-1.62165E-06 -9.57593E-05 -2.23042E-04

THE GLOBAL STRUCTURAL COORDINATE SYSTEM

* PILE TOP DISPLACEMENTS *

PILE GROUP	DISP. X, M	DISP. Y, M	DISP. Z, M	ROT. X,RAD	ROT. Y,RAD	ROT. Z,RAD
1	1.2461E-03	2.3560E-03	-1.4677E-03	-1.6216E-06	-9.5759E-05	-2.2304E-04
2	2.4245E-04	2.3560E-03	-1.4604E-03	-1.6216E-06	-9.5759E-05	-2.2304E-04
3	-7.6124E-04	2.3560E-03	-1.4531E-03	-1.6216E-06	-9.5759E-05	-2.2304E-04
4	1.6771E-03	2.3487E-03	-1.4677E-03	-1.6216E-06	-9.5759E-05	-2.2304E-04
5	6.7337E-04	2.3487E-03	-1.4604E-03	-1.6216E-06	-9.5759E-05	-2.2304E-04
6	-3.3032E-04	2.3487E-03	-1.4531E-03	-1.6216E-06	-9.5759E-05	-2.2304E-04
7	2.1080E-03	2.3414E-03	-1.4677E-03	-1.6216E-06	-9.5759E-05	-2.2304E-04
8	1.1043E-03	2.3414E-03	-1.4604E-03	-1.6216E-06	-9.5759E-05	-2.2304E-04
9	1.0059E-04	2.3414E-03	-1.4531E-03	-1.6216E-06	-9.5759E-05	-2.2304E-04
10	2.5389E-03	2.3341E-03	-1.4677E-03	-1.6216E-06	-9.5759E-05	-2.2304E-04
11	1.5352E-03	2.3341E-03	-1.4604E-03	-1.6216E-06	-9.5759E-05	-2.2304E-04
12	5.3151E-04	2.3341E-03	-1.4531E-03	-1.6216E-06	-9.5759E-05	-2.2304E-04
MINIMUM	-7.6124E-04	2.3341E-03	-1.4677E-03	-1.6216E-06	-9.5759E-05	-2.2304E-04
Pile N.	3	10	1	1	1	1
MAXIMUM	2.5389E-03	2.3560E-03	-1.4531E-03	-1.6216E-06	-9.5759E-05	-2.2304E-04
Pile N.	10	1	3	1	1	1

* PILE TOP REACTIONS *

PILE GROUP	FOR. X, KN	FOR. Y, KN	FOR. Z, KN	MOM X, KN- M	MOM Y, KN- M	MOM Z, KN- M
1	2460.7	598.04	-412.78	-0.4306	973.69	1278.4
2	494.74	465.06	-322.36	-0.4306	806.02	1038.9
3	-1491.3	481.96	-331.48	-0.4306	820.27	1068.8
4	3278.8	566.25	-393.28	-0.4306	939.50	1221.2
5	1373.4	420.18	-293.79	-0.4306	751.55	952.86
6	-654.85	435.41	-302.03	-0.4306	764.70	980.38
7	4096.8	568.04	-396.08	-0.4306	944.83	1222.5
8	2191.4	424.18	-297.70	-0.4306	759.47	959.01
9	205.27	440.11	-306.42	-0.4306	773.50	987.80
10	4914.9	626.60	-436.96	-0.4306	1016.7	1321.3
11	3009.5	513.00	-358.50	-0.4306	874.36	1121.8
12	1084.6	527.65	-366.02	-0.4306	885.04	1146.7
MINIMUM	-1491.3	420.18	-436.96	-0.4306	751.55	952.86
Pile N.	3	5	10	1	5	5
MAXIMUM	4914.9	626.60	-293.79	-0.4306	1016.7	1321.3
Pile N.	10	10	5	1	10	10

THE PILE COORDINATE SYSTEM (LOCAL AXES)

* PILE TOP DISPLACEMENTS *

PILE GROUP	DISP. x, M	DISP. y, M	DISP. z, M	ROT. x,RAD	ROT. y,RAD	ROT. z,RAD
1	1.2461E-03	2.3560E-03	-1.4677E-03	-1.6216E-06	-9.5759E-05	-2.2304E-04
2	2.4245E-04	2.3560E-03	-1.4604E-03	-1.6216E-06	-9.5759E-05	-2.2304E-04
3	-7.6124E-04	2.3560E-03	-1.4531E-03	-1.6216E-06	-9.5759E-05	-2.2304E-04
4	1.6771E-03	2.3487E-03	-1.4677E-03	-1.6216E-06	-9.5759E-05	-2.2304E-04
5	6.7337E-04	2.3487E-03	-1.4604E-03	-1.6216E-06	-9.5759E-05	-2.2304E-04
6	-3.3032E-04	2.3487E-03	-1.4531E-03	-1.6216E-06	-9.5759E-05	-2.2304E-04
7	2.1080E-03	2.3414E-03	-1.4677E-03	-1.6216E-06	-9.5759E-05	-2.2304E-04
8	1.1043E-03	2.3414E-03	-1.4604E-03	-1.6216E-06	-9.5759E-05	-2.2304E-04
9	1.0059E-04	2.3414E-03	-1.4531E-03	-1.6216E-06	-9.5759E-05	-2.2304E-04
10	2.5389E-03	2.3341E-03	-1.4677E-03	-1.6216E-06	-9.5759E-05	-2.2304E-04
11	1.5352E-03	2.3341E-03	-1.4604E-03	-1.6216E-06	-9.5759E-05	-2.2304E-04
12	5.3151E-04	2.3341E-03	-1.4531E-03	-1.6216E-06	-9.5759E-05	-2.2304E-04
MINIMUM	-7.6124E-04	2.3341E-03	-1.4677E-03	-1.6216E-06	-9.5759E-05	-2.2304E-04
Pile N.	3	10	1	1	1	1
MAXIMUM	2.5389E-03	2.3560E-03	-1.4531E-03	-1.6216E-06	-9.5759E-05	-2.2304E-04
Pile N.	10	1	3	1	1	1

* PILE TOP REACTIONS *

PILE GROUP	AXIAL, KN	LAT. y, KN	LAT. z, KN	MOM x, KN- M	MOM y, KN- M	MOM z, KN- M
1	2460.7	598.04	-412.78	-0.4306	973.69	1278.4
2	494.74	465.06	-322.36	-0.4306	806.02	1038.9
3	-1491.3	481.96	-331.48	-0.4306	820.27	1068.8
4	3278.8	566.25	-393.28	-0.4306	939.50	1221.2
5	1373.4	420.18	-293.79	-0.4306	751.55	952.86
6	-654.85	435.41	-302.03	-0.4306	764.70	980.38

APPALTATORE:

Consorzio

Soci



ITINERARIO NAPOLI – BARI

PROGETTAZIONE:

Mandataria

Mandanti



RADDOPPIO TRATTA APICE – ORSARA
I LOTTO FUNZIONALE APICE – HIRPINIA

PROGETTO ESECUTIVO

RELAZIONE DI CALCOLO FONDAZIONI SPALLA A

COMMESSA
IF1N

LOTTO
01 E ZZ

CODIFICA
RG

DOCUMENTO
MD0000 001

REV.
B

FOGLIO
72 di 109

7	4096.8	568.04	-396.08	-0.4306	944.83	1222.5
8	2191.4	424.18	-297.70	-0.4306	759.47	959.01
9	205.27	440.11	-306.42	-0.4306	773.50	987.80
10	4914.9	626.60	-436.96	-0.4306	1016.7	1321.3
11	3009.5	513.00	-358.50	-0.4306	874.36	1121.8
12	1084.6	527.65	-366.02	-0.4306	885.04	1146.7
MINIMUM	-1491.3	420.18	-436.96	-0.4306	751.55	952.86
Pile N.	3	5	10	1	5	5
MAXIMUM	4914.9	626.60	-293.79	-0.4306	1016.7	1321.3
Pile N.	10	10	5	1	10	10

PILE GROUP STRESS, KN/ M**2

1	6242.4
2	4248.5
3	4910.1
4	6505.5
5	4439.8
6	4123.1
7	6981.3
8	4932.1
9	3902.6
10	7813.0
11	5995.6
12	4985.5
MINIMUM	3902.6
Pile N.	9
MAXIMUM	7813.0
Pile N.	10





* EFFECTS FOR LATERALLY LOADED PILE *

* MINIMUM VALUES AND LOCATIONS *

PILE	DISPL. y-DIR M	DISPL. z-DIR M	MOMENT z-DIR KN- M	MOMENT y-DIR KN- M	SHEAR y-DIR KN	SHEAR z-DIR KN	SOIL REACT y-DIR KN/ M	SOIL REACT z-DIR KN/ M	TOTAL STRESS KN/ M**2	FLEX. RIG. z-DIR KN- M**2	FLEX. RIG. y-DIR KN- M**2
1	-2.2469E-05	-1.4677E-03	-1278.4	-403.39	-162.09	-412.82	-81.783	-88.872	1392.5	7.8279E+06	7.8279E+06
x(M)	9.9900	0.0000	0.0000	5.9400	8.6400	0.0000	4.3200	4.3200	27.000	0.0000	0.0000
2	-1.7416E-05	-1.4604E-03	-1038.9	-344.21	-134.75	-322.36	-51.701	-65.909	279.96	7.8279E+06	7.8279E+06
x(M)	10.800	0.0000	0.0000	6.4800	9.4500	0.0000	11.340	4.3200	27.000	0.0000	0.0000
3	-1.7770E-05	-1.4531E-03	-1068.8	-349.12	-137.85	-331.45	-54.584	-68.253	843.91	7.8279E+06	7.8279E+06
x(M)	10.530	0.0000	0.0000	6.2100	9.1800	0.0000	11.070	4.3200	27.000	0.0000	0.0000
4	-2.1177E-05	-1.4677E-03	-1221.2	-391.15	-155.57	-393.34	-73.733	-83.917	1855.4	7.8279E+06	7.8279E+06
x(M)	9.9900	0.0000	0.0000	5.9400	8.6400	0.0000	10.530	4.3200	27.000	0.0000	0.0000
5	-1.6373E-05	-1.4604E-03	-952.86	-324.61	-124.78	-293.81	-44.747	-58.825	777.18	7.8279E+06	7.8279E+06
x(M)	11.070	0.0000	0.0000	6.4800	9.7200	0.0000	11.610	4.3200	27.000	0.0000	0.0000
6	-1.6552E-05	-1.4531E-03	-980.38	-329.63	-127.73	-302.02	-46.790	-60.912	370.57	7.8279E+06	7.8279E+06
x(M)	11.070	0.0000	0.0000	6.4800	9.7200	0.0000	11.610	4.3200	27.000	0.0000	0.0000
7	-2.1372E-05	-1.4677E-03	-1222.5	-393.19	-156.08	-396.15	-74.599	-84.669	2318.3	7.8279E+06	7.8279E+06
x(M)	9.9900	0.0000	0.0000	5.9400	8.6400	0.0000	10.260	4.3200	27.000	0.0000	0.0000
8	-1.6454E-05	-1.4604E-03	-959.01	-327.63	-125.71	-297.73	-45.491	-59.830	1240.1	7.8279E+06	7.8279E+06
x(M)	11.070	0.0000	0.0000	6.4800	9.7200	0.0000	11.610	4.3200	27.000	0.0000	0.0000
9	-1.6689E-05	-1.4531E-03	-987.80	-332.90	-128.99	-306.43	-47.788	-62.040	116.16	7.8279E+06	7.8279E+06
x(M)	10.800	0.0000	0.0000	6.4800	9.4500	0.0000	11.340	4.3200	27.000	0.0000	0.0000
10	-2.3993E-05	-1.4677E-03	-1321.3	-418.36	-167.70	-437.04	-90.841	-95.231	2781.3	7.8279E+06	7.8279E+06
x(M)	9.7200	0.0000	0.0000	5.9400	8.3700	0.0000	10.260	4.3200	27.000	0.0000	0.0000
11	-1.9153E-05	-1.4604E-03	-1121.8	-368.93	-144.84	-358.55	-62.081	-75.146	1703.0	7.8279E+06	7.8279E+06
x(M)	10.260	0.0000	0.0000	6.2100	8.9100	0.0000	10.800	4.3200	27.000	0.0000	0.0000
12	-1.9666E-05	-1.4531E-03	-1146.7	-372.70	-147.56	-366.03	-64.898	-77.114	613.75	7.8279E+06	7.8279E+06
x(M)	10.260	0.0000	0.0000	6.2100	8.9100	0.0000	10.800	4.3200	27.000	0.0000	0.0000
Min.	-2.3993E-05	-1.4677E-03	-1321.3	-418.36	-167.70	-437.04	-90.841	-95.231	116.16	7.8279E+06	7.8279E+06
Pile N.	10	1	10	10	10	10	10	10	9	1	1

* MAXIMUM VALUES AND LOCATIONS *

PILE	DISPL. y-DIR M	DISPL. z-DIR M	MOMENT z-DIR KN- M	MOMENT y-DIR KN- M	SHEAR y-DIR KN	SHEAR z-DIR KN	SOIL REACT y-DIR KN/ M	SOIL REACT z-DIR KN/ M	TOTAL STRESS KN/ M**2	FLEX. RIG. z-DIR KN- M**2	FLEX. RIG. y-DIR KN- M**2
1	2.3560E-03	1.3697E-05	635.52	973.69	598.09	105.26	131.27	51.325	6242.4	7.8279E+06	7.8279E+06
x(M)	0.0000	9.9900	5.6700	0.0000	0.0000	8.6400	4.0500	10.530	0.0000	0.0000	0.0000
2	2.3560E-03	1.0684E-05	545.46	806.02	465.07	87.352	97.710	33.314	4248.5	7.8279E+06	7.8279E+06
x(M)	0.0000	10.800	6.2100	0.0000	0.0000	9.4500	11.340	4.3200	0.0000	0.0000	0.0000
3	2.3560E-03	1.0882E-05	556.20	820.27	481.94	88.996	101.82	34.862	4910.1	7.8279E+06	7.8279E+06
x(M)	0.0000	10.800	5.9400	0.0000	0.0000	9.4500	11.340	4.3200	0.0000	0.0000	0.0000
4	2.3487E-03	1.2949E-05	614.32	939.50	566.32	101.73	123.37	46.621	6505.5	7.8279E+06	7.8279E+06
x(M)	0.0000	10.260	5.9400	0.0000	0.0000	8.9100	4.3200	10.530	0.0000	0.0000	0.0000
5	2.3487E-03	1.0217E-05	513.16	751.55	420.21	81.056	86.789	29.158	4439.8	7.8279E+06	7.8279E+06
x(M)	0.0000	11.340	6.2100	0.0000	0.0000	9.9900	4.3200	11.610	0.0000	0.0000	0.0000
6	2.3487E-03	1.0277E-05	523.63	764.70	435.40	82.729	90.433	30.438	4123.1	7.8279E+06	7.8279E+06
x(M)	0.0000	11.070	6.2100	0.0000	0.0000	9.7200	4.3200	11.610	0.0000	0.0000	0.0000
7	2.3414E-03	1.3069E-05	615.41	944.83	568.13	102.34	123.99	47.393	6981.3	7.8279E+06	7.8279E+06
x(M)	0.0000	10.260	5.6700	0.0000	0.0000	8.9100	4.3200	10.530	0.0000	0.0000	0.0000

APPALTATORE: Consorzio Soci   				ITINERARIO NAPOLI – BARI RADDOPPIO TRATTA APICE – ORSARA I LOTTO FUNZIONALE APICE – HIRPINIA					
PROGETTAZIONE: Mandataria Mandanti   									
PROGETTO ESECUTIVO RELAZIONE DI CALCOLO FONDAZIONI SPALLA A									

	8	2.3414E-03	1.0252E-05	516.18	759.47	424.22	82.029	87.927	29.800	4932.1	7.8279E+06	7.8279E+06
x(M)		0.0000	11.070	6.2100	0.0000	0.0000	9.7200	4.3200	11.610	0.0000	0.0000	0.0000
	9	2.3414E-03	1.0383E-05	527.05	773.50	440.11	83.800	91.748	31.133	3902.6	7.8279E+06	7.8279E+06
x(M)		0.0000	11.070	6.2100	0.0000	0.0000	9.7200	4.3200	11.610	0.0000	0.0000	0.0000
	10	2.3341E-03	1.4666E-05	653.16	1016.7	626.71	109.95	139.38	57.920	7813.0	7.8279E+06	7.8279E+06
x(M)		0.0000	9.9900	5.6700	0.0000	0.0000	8.6400	4.0500	10.260	0.0000	0.0000	0.0000
	11	2.3341E-03	1.1789E-05	578.86	874.36	513.06	94.992	110.17	39.751	5995.6	7.8279E+06	7.8279E+06
x(M)		0.0000	10.530	5.9400	0.0000	0.0000	9.1800	4.3200	11.070	0.0000	0.0000	0.0000
	12	2.3341E-03	1.1944E-05	587.92	885.04	527.67	96.076	113.75	41.228	4985.5	7.8279E+06	7.8279E+06
x(M)		0.0000	10.530	5.9400	0.0000	0.0000	9.1800	4.3200	10.800	0.0000	0.0000	0.0000
Max.	2.3560E-03	1.4666E-05	653.16	1016.7	626.71	109.95	139.38	57.920	7813.0	7.8279E+06	7.8279E+06	
Pile N.	1	10	10	10	10	10	10	10	10	1	1	

LOAD CASE : 7
CASE NAME : Load Case
LOAD TYPE : Special, Sp

REDUCTION FACTORS FOR CLOSELY-SPACED PILE GROUPS, COMBINED Y AND Z DIRECTIONS
ESTIMATED USING MOVEMENT IN THE DIRECTION OF PILE CAP DISPLACEMENTS

GROUP NO	P-FACTOR	Y-FACTOR
1	0.6413	1.0000
2	0.5116	1.0000
3	0.5845	1.0000
4	0.5970	1.0000
5	0.4682	1.0000
6	0.5364	1.0000
7	0.6234	1.0000
8	0.4960	1.0000
9	0.5657	1.0000
10	0.8661	1.0000
11	0.7715	1.0000
12	0.8250	1.0000

* TABLE L * COMPUTATION ON PILE CAP

* EQUIVALENT CONCENTRATED LOAD AT ORIGIN *

VERT. LOAD, KN	HOR. LOAD Y, KN	HOR. LOAD Z, KN
29966.0	5712.30	-14056.9
MOMENT X, KN- M	MOMENT Y, KN- M	MOMENT Z, KN- M
-2188.00	-1.54123E+05	-54337.2

* DISPLACEMENT OF GROUPED PILE FOUNDATION AT ORIGIN *

VERTICAL, M	HORIZONTAL Y, M	HORIZONTAL Z, M
1.33964E-03	3.24031E-03	-7.15355E-03
ANGLE ROT. X, RAD	ANGLE ROT. Y, RAD	ANGLE ROT. Z, RAD
-4.30247E-05	-3.47409E-04	-2.37099E-04

THE GLOBAL STRUCTURAL COORDINATE SYSTEM

* PILE TOP DISPLACEMENTS *

PILE GROUP	DISP. X, M	DISP. Y, M	DISP. Z, M	ROT. X, RAD	ROT. Y, RAD	ROT. Z, RAD
*****	*****	*****	*****	*****	*****	*****
1	6.1573E-05	3.5307E-03	-7.3472E-03	-4.3025E-05	-3.4741E-04	-2.3710E-04
2	-1.0054E-03	3.5307E-03	-7.1535E-03	-4.3025E-05	-3.4741E-04	-2.3710E-04
3	-2.0723E-03	3.5307E-03	-6.9599E-03	-4.3025E-05	-3.4741E-04	-2.3710E-04
4	1.6249E-03	3.3371E-03	-7.3472E-03	-4.3025E-05	-3.4741E-04	-2.3710E-04
5	5.5797E-04	3.3371E-03	-7.1535E-03	-4.3025E-05	-3.4741E-04	-2.3710E-04
6	-5.0898E-04	3.3371E-03	-6.9599E-03	-4.3025E-05	-3.4741E-04	-2.3710E-04
7	3.1883E-03	3.1435E-03	-7.3472E-03	-4.3025E-05	-3.4741E-04	-2.3710E-04
8	2.1213E-03	3.1435E-03	-7.1535E-03	-4.3025E-05	-3.4741E-04	-2.3710E-04
9	1.0544E-03	3.1435E-03	-6.9599E-03	-4.3025E-05	-3.4741E-04	-2.3710E-04
10	4.7516E-03	2.9499E-03	-7.3472E-03	-4.3025E-05	-3.4741E-04	-2.3710E-04
11	3.6846E-03	2.9499E-03	-7.1535E-03	-4.3025E-05	-3.4741E-04	-2.3710E-04
12	2.6177E-03	2.9499E-03	-6.9599E-03	-4.3025E-05	-3.4741E-04	-2.3710E-04
MINIMUM	-2.0723E-03	2.9499E-03	-7.3472E-03	-4.3025E-05	-3.4741E-04	-2.3710E-04
Pile N.	3	1	1	1	1	1
MAXIMUM	4.7516E-03	3.5307E-03	-6.9599E-03	-4.3025E-05	-3.4741E-04	-2.3710E-04
Pile N.	10	1	3	1	1	1

APPALTATORE: Consorzio Soci   		ITINERARIO NAPOLI – BARI RADDOPPIO TRATTA APICE – ORSARA I LOTTO FUNZIONALE APICE – HIRPINIA					
PROGETTAZIONE: Mandataria Mandanti   							
PROGETTO ESECUTIVO RELAZIONE DI CALCOLO FONDAZIONI SPALLA A		COMMESSA IF1N	LOTTO 01 E ZZ	CODIFICA RG	DOCUMENTO MD0000 001	REV. B	FOGLIO 74 di 109

* PILE TOP REACTIONS *

PILE GROUP	FOR. X, KN	FOR. Y, KN	FOR. Z, KN	MOM X, KN- M	MOM Y, KN- M	MOM Z, KN- M
*****	*****	*****	*****	*****	*****	*****
1	125.64	540.63	-1218.4	-11.424	3518.4	1452.4
2	-1946.9	466.06	-1022.0	-11.424	3049.0	1291.3
3	-3938.2	517.96	-1095.6	-11.424	3162.1	1399.8
4	3179.8	478.76	-1162.6	-11.424	3404.9	1281.0
5	1138.6	407.43	-964.16	-11.424	2926.8	1125.4
6	-1009.0	454.19	-1035.7	-11.424	3038.2	1224.1
7	6147.6	457.44	-1200.4	-11.424	3490.5	1194.5
8	4122.1	392.69	-1005.0	-11.424	3021.8	1054.7
9	2096.7	436.91	-1076.8	-11.424	3131.6	1146.9
10	8167.4	534.58	-1509.8	-11.424	4130.6	1304.5
11	6817.8	497.31	-1365.7	-11.424	3787.8	1228.9
12	5064.5	528.33	-1400.7	-11.424	3806.0	1288.5
MINIMUM	-3938.2	392.69	-1509.8	-11.424	2926.8	1054.7
Pile N.	3	8	10	1	5	8
MAXIMUM	8167.4	540.63	-964.16	-11.424	4130.6	1452.4
Pile N.	10	1	5	1	10	1

THE PILE COORDINATE SYSTEM (LOCAL AXES)

* PILE TOP DISPLACEMENTS *

PILE GROUP	DISP. x, M	DISP. y, M	DISP. z, M	ROT. x,RAD	ROT. y,RAD	ROT. z,RAD
*****	*****	*****	*****	*****	*****	*****
1	6.1573E-05	3.5307E-03	-7.3472E-03	-4.3025E-05	-3.4741E-04	-2.3710E-04
2	-1.0054E-03	3.5307E-03	-7.1535E-03	-4.3025E-05	-3.4741E-04	-2.3710E-04
3	-2.0723E-03	3.5307E-03	-6.9599E-03	-4.3025E-05	-3.4741E-04	-2.3710E-04
4	1.6249E-03	3.3371E-03	-7.3472E-03	-4.3025E-05	-3.4741E-04	-2.3710E-04
5	5.5797E-04	3.3371E-03	-7.1535E-03	-4.3025E-05	-3.4741E-04	-2.3710E-04
6	-5.0898E-04	3.3371E-03	-6.9599E-03	-4.3025E-05	-3.4741E-04	-2.3710E-04
7	3.1883E-03	3.1435E-03	-7.3472E-03	-4.3025E-05	-3.4741E-04	-2.3710E-04
8	2.1213E-03	3.1435E-03	-7.1535E-03	-4.3025E-05	-3.4741E-04	-2.3710E-04
9	1.0544E-03	3.1435E-03	-6.9599E-03	-4.3025E-05	-3.4741E-04	-2.3710E-04
10	4.7516E-03	2.9499E-03	-7.3472E-03	-4.3025E-05	-3.4741E-04	-2.3710E-04
11	3.6846E-03	2.9499E-03	-7.1535E-03	-4.3025E-05	-3.4741E-04	-2.3710E-04
12	2.6177E-03	2.9499E-03	-6.9599E-03	-4.3025E-05	-3.4741E-04	-2.3710E-04
MINIMUM	-2.0723E-03	2.9499E-03	-7.3472E-03	-4.3025E-05	-3.4741E-04	-2.3710E-04
Pile N.	3	10	1	1	1	1
MAXIMUM	4.7516E-03	3.5307E-03	-6.9599E-03	-4.3025E-05	-3.4741E-04	-2.3710E-04
Pile N.	10	1	3	1	1	1

* PILE TOP REACTIONS *

PILE GROUP	AXIAL, KN	LAT. y, KN	LAT. z, KN	MOM x, KN- M	MOM y, KN- M	MOM z, KN- M
*****	*****	*****	*****	*****	*****	*****
1	125.64	540.63	-1218.4	-11.424	3518.4	1452.4
2	-1946.9	466.06	-1022.0	-11.424	3049.0	1291.3
3	-3938.2	517.96	-1095.6	-11.424	3162.1	1399.8
4	3179.8	478.76	-1162.6	-11.424	3404.9	1281.0
5	1138.6	407.43	-964.16	-11.424	2926.8	1125.4
6	-1009.0	454.19	-1035.7	-11.424	3038.2	1224.1
7	6147.6	457.44	-1200.4	-11.424	3490.5	1194.5
8	4122.1	392.69	-1005.0	-11.424	3021.8	1054.7
9	2096.7	436.91	-1076.8	-11.424	3131.6	1146.9
10	8167.4	534.58	-1509.8	-11.424	4130.6	1304.5
11	6817.8	497.31	-1365.7	-11.424	3787.8	1228.9
12	5064.5	528.33	-1400.7	-11.424	3806.0	1288.5
MINIMUM	-3938.2	392.69	-1509.8	-11.424	2926.8	1054.7
Pile N.	3	8	10	1	5	8
MAXIMUM	8167.4	540.63	-964.16	-11.424	4130.6	1452.4
Pile N.	10	1	5	1	10	1

PILE GROUP STRESS, KN/ M**2

PILE GROUP	STRESS, KN/ M**2
*****	*****
1	1.1559E+04
2	1.1095E+04
3	1.2665E+04
4	1.2779E+04
5	1.0108E+04
6	1.0457E+04
7	1.4613E+04
8	1.1992E+04
9	1.1252E+04
10	1.7695E+04
11	1.5876E+04
12	1.4993E+04
MINIMUM	1.0108E+04
Pile N.	5
MAXIMUM	1.7695E+04

APPALTATORE:		ITINERARIO NAPOLI – BARI RADDOPPIO TRATTA APICE – ORSARA I LOTTO FUNZIONALE APICE – HIRPINIA					
Consorzio 	Soci  						
PROGETTAZIONE:							
Mandataria 	Mandanti  						
PROGETTO ESECUTIVO		COMMESSA	LOTTO	CODIFICA	DOCUMENTO	REV.	FOGLIO
RELAZIONE DI CALCOLO FONDAZIONI SPALLA A		IF1N	01 E ZZ	RG	MD0000 001	B	75 di 109

Pile N. 10

* EFFECTS FOR LATERALLY LOADED PILE *

* MINIMUM VALUES AND LOCATIONS *

PILE	DISPL. y-DIR M	DISPL. z-DIR M	MOMENT z-DIR KN- M	MOMENT y-DIR KN- M	SHEAR y-DIR KN	SHEAR z-DIR KN	SOIL REACT y-DIR KN/ M	SOIL REACT z-DIR KN/ M	TOTAL STRESS KN/ M**2	FLEX. RIG. z-DIR KN- M**2	FLEX. RIG. y-DIR KN- M**2
1	-1.9905E-05	-7.3472E-03	-1452.4	-1339.1	-155.43	-1218.4	-48.264	-229.60	71.100	7.8279E+06	7.8279E+06
x (M)	12.420	0.0000	0.0000	7.2900	10.800	0.0000	12.420	4.3200	27.000	0.0000	0.0000
2	-2.2316E-05	-7.1536E-03	-1291.3	-1187.1	-143.13	-1021.9	-41.321	-184.22	1101.7	7.8279E+06	7.8279E+06
x (M)	12.690	0.0000	0.0000	7.5600	11.340	0.0000	12.960	4.3200	27.000	0.0000	0.0000
3	-2.0661E-05	-6.9599E-03	-1399.8	-1227.3	-151.83	-1095.4	-45.914	-203.42	2232.6	7.8279E+06	7.8279E+06
x (M)	12.420	0.0000	0.0000	7.2900	11.070	0.0000	12.420	4.3200	27.000	0.0000	0.0000
4	-1.9378E-05	-7.3472E-03	-1281.0	-1302.2	-142.22	-1162.8	-43.057	-216.50	1799.4	7.8279E+06	7.8279E+06
x (M)	12.420	0.0000	0.0000	7.2900	11.070	0.0000	12.420	4.3200	27.000	0.0000	0.0000
5	-2.1914E-05	-7.1536E-03	-1125.4	-1149.7	-129.97	-964.22	-36.411	-170.98	644.30	7.8279E+06	7.8279E+06
x (M)	12.960	0.0000	0.0000	7.8300	11.340	0.0000	12.960	4.3200	27.000	0.0000	0.0000
6	-2.0158E-05	-6.9599E-03	-1224.1	-1187.3	-137.76	-1035.6	-40.572	-189.43	570.99	7.8279E+06	7.8279E+06
x (M)	12.690	0.0000	0.0000	7.5600	11.070	0.0000	12.690	4.3200	27.000	0.0000	0.0000
7	-1.7551E-05	-7.3472E-03	-1194.5	-1332.4	-134.95	-1200.8	-41.479	-225.98	3478.8	7.8279E+06	7.8279E+06
x (M)	12.420	0.0000	0.0000	7.2900	10.800	0.0000	12.420	4.3200	27.000	0.0000	0.0000
8	-1.9693E-05	-7.1536E-03	-1054.7	-1180.6	-123.55	-1005.2	-35.380	-180.92	2332.7	7.8279E+06	7.8279E+06
x (M)	12.690	0.0000	0.0000	7.5600	11.340	0.0000	12.690	4.3200	27.000	0.0000	0.0000
9	-1.8264E-05	-6.9599E-03	-1146.9	-1219.4	-131.29	-1076.9	-39.406	-199.60	1186.5	7.8279E+06	7.8279E+06
x (M)	12.420	0.0000	0.0000	7.2900	11.070	0.0000	12.420	4.3200	27.000	0.0000	0.0000
10	-1.4221E-05	-7.3472E-03	-1304.5	-1553.1	-145.73	-1510.4	-49.615	-302.40	4621.8	7.8279E+06	7.8279E+06
x (M)	11.610	0.0000	0.0000	6.7500	10.260	0.0000	11.610	4.3200	27.000	0.0000	0.0000
11	-1.4623E-05	-7.1536E-03	-1228.9	-1438.4	-138.21	-1366.1	-45.675	-268.53	3858.1	7.8279E+06	7.8279E+06
x (M)	11.880	0.0000	0.0000	7.0200	10.530	0.0000	11.880	4.3200	27.000	0.0000	0.0000
12	-1.4317E-05	-6.9599E-03	-1288.5	-1452.7	-143.47	-1401.0	-48.734	-279.13	2865.9	7.8279E+06	7.8279E+06
x (M)	11.610	0.0000	0.0000	6.7500	10.260	0.0000	11.610	4.3200	27.000	0.0000	0.0000
Min.	-2.2316E-05	-7.3472E-03	-1452.4	-1553.1	-155.43	-1510.4	-49.615	-302.40	71.100	7.8279E+06	7.8279E+06
Pile N.	2	1	1	10	1	10	10	10	1	1	1

* MAXIMUM VALUES AND LOCATIONS *

PILE	DISPL. y-DIR M	DISPL. z-DIR M	MOMENT z-DIR KN- M	MOMENT y-DIR KN- M	SHEAR y-DIR KN	SHEAR z-DIR KN	SOIL REACT y-DIR KN/ M	SOIL REACT z-DIR KN/ M	TOTAL STRESS KN/ M**2	FLEX. RIG. z-DIR KN- M**2	FLEX. RIG. y-DIR KN- M**2
1	3.5307E-03	4.4016E-05	635.17	3518.4	540.64	343.12	104.29	106.73	1.1559E+04	7.8279E+06	7.8279E+06
x (M)	0.0000	12.420	7.0200	0.0000	0.0000	11.070	4.3200	12.420	0.0000	0.0000	0.0000
2	3.5307E-03	4.7755E-05	577.69	3049.0	466.02	307.88	86.188	89.256	1.1095E+04	7.8279E+06	7.8279E+06
x (M)	0.0000	12.690	7.2900	0.0000	0.0000	11.340	4.3200	12.960	0.0000	0.0000	0.0000
3	3.5307E-03	4.2766E-05	615.25	3162.1	517.86	315.13	98.238	95.861	1.2665E+04	7.8279E+06	7.8279E+06
x (M)	0.0000	12.420	7.0200	0.0000	0.0000	11.070	4.3200	12.690	0.0000	0.0000	0.0000
4	3.3371E-03	4.5676E-05	582.51	3404.9	478.83	336.50	91.862	102.34	1.2779E+04	7.8279E+06	7.8279E+06
x (M)	0.0000	12.420	7.0200	0.0000	0.0000	11.070	4.3200	12.690	0.0000	0.0000	0.0000
5	3.3371E-03	5.0535E-05	526.67	2926.8	407.45	297.86	74.710	84.221	1.0108E+04	7.8279E+06	7.8279E+06
x (M)	0.0000	12.960	7.5600	0.0000	0.0000	11.340	4.3200	13.230	0.0000	0.0000	0.0000
6	3.3371E-03	4.4974E-05	561.11	3038.2	454.17	304.85	85.449	90.518	1.0457E+04	7.8279E+06	7.8279E+06
x (M)	0.0000	12.690	7.2900	0.0000	0.0000	11.340	4.3200	12.690	0.0000	0.0000	0.0000
7	3.1435E-03	4.4696E-05	560.32	3490.5	457.57	342.19	89.164	105.64	1.4613E+04	7.8279E+06	7.8279E+06
x (M)	0.0000	12.420	7.0200	0.0000	0.0000	11.070	4.3200	12.420	0.0000	0.0000	0.0000
8	3.1435E-03	4.8661E-05	509.51	3021.8	392.76	306.65	73.503	88.286	1.1992E+04	7.8279E+06	7.8279E+06
x (M)	0.0000	12.960	7.2900	0.0000	0.0000	11.340	4.3200	12.960	0.0000	0.0000	0.0000
9	3.1435E-03	4.3443E-05	542.49	3131.6	436.95	313.70	83.726	94.792	1.1252E+04	7.8279E+06	7.8279E+06
x (M)	0.0000	12.420	7.0200	0.0000	0.0000	11.070	4.3200	12.690	0.0000	0.0000	0.0000
10	2.9499E-03	3.7715E-05	612.85	4130.6	534.76	385.01	110.52	132.85	1.7695E+04	7.8279E+06	7.8279E+06
x (M)	0.0000	11.610	6.4800	0.0000	0.0000	10.530	4.3200	11.880	0.0000	0.0000	0.0000
11	2.9499E-03	3.8354E-05	584.12	3787.8	497.45	360.99	101.10	120.15	1.5876E+04	7.8279E+06	7.8279E+06
x (M)	0.0000	11.880	6.4800	0.0000	0.0000	10.530	4.3200	12.150	0.0000	0.0000	0.0000
12	2.9499E-03	3.5669E-05	606.30	3806.0	528.44	359.52	108.46	123.12	1.4993E+04	7.8279E+06	7.8279E+06
x (M)	0.0000	11.880	6.4800	0.0000	0.0000	10.530	4.3200	11.880	0.0000	0.0000	0.0000
Max.	3.5307E-03	5.0535E-05	635.17	4130.6	540.64	385.01	110.52	132.85	1.7695E+04	7.8279E+06	7.8279E+06
Pile N.	1	5	1	10	1	10	10	10	10	1	1

LOAD CASE : 8
CASE NAME : Load Case
LOAD TYPE : Special, Sp

REDUCTION FACTORS FOR CLOSELY-SPACED PILE GROUPS, COMBINED Y AND Z DIRECTIONS
ESTIMATED USING MOVEMENT IN THE DIRECTION OF PILE CAP DISPLACEMENTS

GROUP NO	P-FACTOR	Y-FACTOR
1	0.8329	1.0000
2	0.7780	1.0000
3	0.8661	1.0000
4	0.5683	1.0000
5	0.4960	1.0000

APPALTATORE:

Consorzio

Soci



ITINERARIO NAPOLI – BARI

PROGETTAZIONE:

Mandataria

Mandanti



RADDOPPIO TRATTA APICE – ORSARA
I LOTTO FUNZIONALE APICE – HIRPINIA

PROGETTO ESECUTIVO

RELAZIONE DI CALCOLO FONDAZIONI SPALLA A

COMMESSA	LOTTO	CODIFICA	DOCUMENTO	REV.	FOGLIO
IF1N	01 E ZZ	RG	MD0000 001	B	77 di 109

1	3.3790E-03	-2.8936E-03	7.1346E-03	8.2321E-06	3.6067E-04	2.0149E-04
2	4.2857E-03	-2.8936E-03	7.0975E-03	8.2321E-06	3.6067E-04	2.0149E-04
3	5.1924E-03	-2.8936E-03	7.0605E-03	8.2321E-06	3.6067E-04	2.0149E-04
4	1.7560E-03	-2.8565E-03	7.1346E-03	8.2321E-06	3.6067E-04	2.0149E-04
5	2.6627E-03	-2.8565E-03	7.0975E-03	8.2321E-06	3.6067E-04	2.0149E-04
6	3.5694E-03	-2.8565E-03	7.0605E-03	8.2321E-06	3.6067E-04	2.0149E-04
7	1.3302E-04	-2.8195E-03	7.1346E-03	8.2321E-06	3.6067E-04	2.0149E-04
8	1.0397E-03	-2.8195E-03	7.0975E-03	8.2321E-06	3.6067E-04	2.0149E-04
9	1.9464E-03	-2.8195E-03	7.0605E-03	8.2321E-06	3.6067E-04	2.0149E-04
10	-1.4900E-03	-2.7825E-03	7.1346E-03	8.2321E-06	3.6067E-04	2.0149E-04
11	-5.8326E-04	-2.7825E-03	7.0975E-03	8.2321E-06	3.6067E-04	2.0149E-04
12	3.2345E-04	-2.7825E-03	7.0605E-03	8.2321E-06	3.6067E-04	2.0149E-04
MINIMUM	-1.4900E-03	-2.8936E-03	7.0605E-03	8.2321E-06	3.6067E-04	2.0149E-04
Pile N.	10	1	3	1	1	1
MAXIMUM	5.1924E-03	-2.7825E-03	7.1346E-03	8.2321E-06	3.6067E-04	2.0149E-04
Pile N.	3	10	1	1	1	1

* PILE TOP REACTIONS *

PILE GROUP	AXIAL, KN	LAT. y, KN	LAT. z, KN	MOM x, KN- M	MOM y, KN- M	MOM z, KN- M
1	6431.2	-539.54	1429.2	2.1858	-3882.1	-1375.1
2	7578.1	-514.65	1356.7	2.1858	-3728.5	-1326.3
3	8725.1	-556.28	1454.4	2.1858	-3917.4	-1409.9
4	3428.7	-405.21	1099.9	2.1858	-3195.3	-1089.9
5	5150.0	-368.03	995.97	2.1858	-2965.2	-1010.8
6	6672.1	-429.62	1149.7	2.1858	-3290.1	-1142.7
7	271.44	-384.25	1062.2	2.1858	-3108.4	-1033.8
8	2068.9	-347.72	958.61	2.1858	-2877.4	-956.35
9	3790.2	-409.72	1116.2	2.1858	-3213.8	-1090.3
10	-2851.4	-401.84	1127.8	2.1858	-3242.9	-1060.2
11	-1156.3	-364.25	1019.5	2.1858	-3004.8	-981.64
12	660.02	-425.06	1176.0	2.1858	-3334.2	-1111.2
MINIMUM	-2851.4	-556.28	958.61	2.1858	-3917.4	-1409.9
Pile N.	10	3	8	1	3	3
MAXIMUM	8725.1	-347.72	1454.4	2.1858	-2877.4	-956.35
Pile N.	3	8	3	1	8	8

PILE GROUP STRESS, KN/ M**2

1	1.6069E+04
2	1.6232E+04
3	1.7503E+04
4	1.2129E+04
5	1.2369E+04
6	1.4287E+04
7	1.0040E+04
8	1.0322E+04
9	1.2387E+04
10	1.1910E+04
11	1.0195E+04
12	1.0981E+04
MINIMUM	1.0040E+04
Pile N.	7
MAXIMUM	1.7503E+04
Pile N.	3

* EFFECTS FOR LATERALLY LOADED PILE *

* MINIMUM VALUES AND LOCATIONS *

PILE	DISPL. y-DIR	DISPL. z-DIR	MOMENT z-DIR	MOMENT y-DIR	SHEAR y-DIR	SHEAR z-DIR	SOIL REACT y-DIR	SOIL REACT z-DIR	TOTAL STRESS	FLEX. RIG. z-DIR	FLEX. RIG. y-DIR
	M	M	KN- M	KN- M	KN	KN	KN/ M	KN/ M	KN/ M**2	KN- M**2	KN- M**2
1	-2.8936E-03	-3.6539E-05	-596.87	-3882.1	-539.69	-368.13	-109.68	-125.92	3639.3	7.8279E+06	7.8279E+06
x(M)	0.0000	11.610	6.4800	0.0000	0.0000	10.530	4.3200	11.880	27.000	0.0000	0.0000
2	-2.8936E-03	-3.7661E-05	-578.89	-3728.5	-514.83	-358.31	-103.59	-119.48	4288.3	7.8279E+06	7.8279E+06
x(M)	0.0000	11.880	6.7500	0.0000	0.0000	10.530	4.3200	11.880	27.000	0.0000	0.0000
3	-2.8936E-03	-3.5985E-05	-610.25	-3917.4	-556.49	-371.36	-113.92	-128.27	4937.4	7.8279E+06	7.8279E+06
x(M)	0.0000	11.610	6.4800	0.0000	0.0000	10.260	4.3200	11.880	27.000	0.0000	0.0000
4	-2.8565E-03	-4.4490E-05	-494.09	-3195.3	-405.27	-321.20	-77.207	-97.000	1940.2	7.8279E+06	7.8279E+06
x(M)	0.0000	12.420	7.0200	0.0000	0.0000	11.070	4.3200	12.690	27.000	0.0000	0.0000
5	-2.8565E-03	-4.7647E-05	-466.70	-2965.2	-368.12	-303.55	-68.490	-87.727	2914.3	7.8279E+06	7.8279E+06
x(M)	0.0000	12.690	7.2900	0.0000	0.0000	11.340	4.3200	12.960	27.000	0.0000	0.0000
6	-2.8565E-03	-4.2331E-05	-514.01	-3290.1	-429.75	-326.61	-83.221	-101.68	3775.6	7.8279E+06	7.8279E+06
x(M)	0.0000	12.420	7.0200	0.0000	0.0000	11.070	4.3200	12.420	27.000	0.0000	0.0000
7	-2.8195E-03	-4.5947E-05	-475.24	-3108.4	-384.25	-312.59	-72.440	-93.054	153.60	7.8279E+06	7.8279E+06
x(M)	0.0000	12.690	7.2900	0.0000	0.0000	11.070	4.3200	12.690	27.000	0.0000	0.0000
8	-2.8195E-03	-4.9478E-05	-448.21	-2877.4	-347.75	-296.53	-63.936	-83.971	1170.8	7.8279E+06	7.8279E+06
x(M)	0.0000	12.960	7.2900	0.0000	0.0000	11.340	4.3200	12.960	27.000	0.0000	0.0000
9	-2.8195E-03	-4.3198E-05	-496.32	-3213.8	-409.79	-321.70	-78.694	-98.302	2144.8	7.8279E+06	7.8279E+06
x(M)	0.0000	12.420	7.0200	0.0000	0.0000	11.070	4.3200	12.690	27.000	0.0000	0.0000
10	-2.7824E-03	-4.3605E-05	-486.11	-3242.9	-401.79	-323.52	-76.862	-98.672	1613.5	7.8279E+06	7.8279E+06
x(M)	0.0000	12.420	7.0200	0.0000	0.0000	11.070	4.3200	12.690	27.000	0.0000	0.0000

APPALTATORE: Consorzio Soci   		ITINERARIO NAPOLI – BARI RADDOPPIO TRATTA APICE – ORSARA I LOTTO FUNZIONALE APICE – HIRPINIA			
PROGETTAZIONE: Mandataria Mandanti   					
PROGETTO ESECUTIVO RELAZIONE DI CALCOLO FONDAZIONI SPALLA A					
COMMESSA	LOTTO	CODIFICA	DOCUMENTO	REV.	FOGLIO
IF1N	01 E ZZ	RG	MD0000 001	B	78 di 109

11	-2.7824E-03	-4.6765E-05	-458.16	-3004.8	-364.23	-305.37	-68.023	-89.132	654.33	7.8279E+06	7.8279E+06
x(M)	0.0000	12.690	7.2900	0.0000	0.0000	11.340	4.3200	12.960	27.000	0.0000	0.0000
12	-2.7824E-03	-4.1399E-05	-504.82	-3334.2	-425.07	-328.69	-82.611	-103.47	373.49	7.8279E+06	7.8279E+06
x(M)	0.0000	12.420	7.0200	0.0000	0.0000	10.800	4.3200	12.420	27.000	0.0000	0.0000
Min. Pile N.	-2.8936E-03	-4.9478E-05	-610.25	-3917.4	-556.49	-371.36	-113.92	-128.27	153.60	7.8279E+06	7.8279E+06
	1	8	3	3	3	3	3	3	7	1	1

* MAXIMUM VALUES AND LOCATIONS *

PILE	DISPL. y-DIR M	DISPL. z-DIR M	MOMENT z-DIR KN- M	MOMENT y-DIR KN- M	SHEAR y-DIR KN	SHEAR z-DIR KN	SOIL REACT y-DIR KN/ M	SOIL REACT z-DIR KN/ M	TOTAL STRESS KN/ M**2	FLEX. RIG. z-DIR KN- M**2	FLEX. RIG. y-DIR KN- M**2
*****	*****	*****	*****	*****	*****	*****	*****	*****	*****	*****	*****
1	1.4324E-05	7.1346E-03	1375.1	1488.1	143.06	1429.7	48.711	285.34	1.6069E+04	7.8279E+06	7.8279E+06
x(M)	11.610	0.0000	0.0000	6.7500	10.260	0.0000	11.610	4.3200	0.0000	0.0000	0.0000
2	1.4661E-05	7.0975E-03	1326.3	1435.4	139.76	1357.2	46.513	267.95	1.6232E+04	7.8279E+06	7.8279E+06
x(M)	11.880	0.0000	0.0000	6.7500	10.530	0.0000	11.880	4.3200	0.0000	0.0000	0.0000
3	1.4227E-05	7.0605E-03	1409.9	1504.2	147.58	1455.0	50.621	292.84	1.7503E+04	7.8279E+06	7.8279E+06
x(M)	11.610	0.0000	0.0000	6.7500	10.260	0.0000	11.610	4.3200	0.0000	0.0000	0.0000
4	1.6844E-05	7.1346E-03	1089.0	1250.0	121.19	1100.1	36.336	204.26	1.2129E+04	7.8279E+06	7.8279E+06
x(M)	12.420	0.0000	0.0000	7.2900	11.070	0.0000	12.420	4.3200	0.0000	0.0000	0.0000
5	1.8094E-05	7.0975E-03	1010.8	1175.8	114.57	996.24	32.976	180.22	1.2369E+04	7.8279E+06	7.8279E+06
x(M)	12.690	0.0000	0.0000	7.5600	11.340	0.0000	12.960	4.3200	0.0000	0.0000	0.0000
6	1.6128E-05	7.0605E-03	1142.7	1285.3	125.36	1150.1	38.741	217.51	1.4287E+04	7.8279E+06	7.8279E+06
x(M)	12.420	0.0000	0.0000	7.2900	10.800	0.0000	12.420	4.3200	0.0000	0.0000	0.0000
7	1.6977E-05	7.1346E-03	1033.8	1219.6	116.64	1062.2	34.384	194.73	1.0040E+04	7.8279E+06	7.8279E+06
x(M)	12.690	0.0000	0.0000	7.5600	11.070	0.0000	12.690	4.3200	0.0000	0.0000	0.0000
8	1.8353E-05	7.0975E-03	956.35	1145.8	110.56	958.71	31.147	170.95	1.0322E+04	7.8279E+06	7.8279E+06
x(M)	12.960	0.0000	0.0000	7.8300	11.340	0.0000	12.960	4.3200	0.0000	0.0000	0.0000
9	1.6253E-05	7.0605E-03	1090.3	1258.5	120.59	1116.4	36.862	208.98	1.2387E+04	7.8279E+06	7.8279E+06
x(M)	12.420	0.0000	0.0000	7.2900	11.070	0.0000	12.420	4.3200	0.0000	0.0000	0.0000
10	1.5968E-05	7.1346E-03	1060.2	1263.3	118.04	1127.6	35.902	209.89	1.1910E+04	7.8279E+06	7.8279E+06
x(M)	12.420	0.0000	0.0000	7.2900	11.070	0.0000	12.420	4.3200	0.0000	0.0000	0.0000
11	1.7173E-05	7.0975E-03	981.64	1186.1	111.43	1019.4	32.504	184.75	1.0195E+04	7.8279E+06	7.8279E+06
x(M)	12.690	0.0000	0.0000	7.5600	11.340	0.0000	12.690	4.3200	0.0000	0.0000	0.0000
12	1.5361E-05	7.0605E-03	1111.2	1297.0	122.70	1176.0	38.108	222.85	1.0981E+04	7.8279E+06	7.8279E+06
x(M)	12.150	0.0000	0.0000	7.2900	10.800	0.0000	12.420	4.3200	0.0000	0.0000	0.0000
Max. Pile N.	1.8353E-05	7.1346E-03	1409.9	1504.2	147.58	1455.0	50.621	292.84	1.7503E+04	7.8279E+06	7.8279E+06
	8	1	3	3	3	3	3	3	3	1	1

LOAD CASE : 9
CASE NAME : Load Case
LOAD TYPE : Special, Sp

REDUCTION FACTORS FOR CLOSELY-SPACED PILE GROUPS, COMBINED Y AND Z DIRECTIONS
ESTIMATED USING MOVEMENT IN THE DIRECTION OF PILE CAP DISPLACEMENTS

GROUP NO	P-FACTOR	Y-FACTOR
1	0.8561	1.0000
2	0.5758	1.0000
3	0.5845	1.0000
4	0.7960	1.0000
5	0.4938	1.0000
6	0.4977	1.0000
7	0.7970	1.0000
8	0.4951	1.0000
9	0.4993	1.0000
10	0.8661	1.0000
11	0.5904	1.0000
12	0.5991	1.0000

* TABLE L * COMPUTATION ON PILE CAP

* EQUIVALENT CONCENTRATED LOAD AT ORIGIN *

VERT. LOAD, KN	HOR. LOAD Y, KN	HOR. LOAD Z, KN
32966.0	18789.1	-4279.00
MOMENT X, KN- M	MOMENT Y, KN- M	MOMENT Z, KN- M
-713.000	-45399.2	-1.74685E+05

* DISPLACEMENT OF GROUPED PILE FOUNDATION AT ORIGIN *

VERTICAL, M	HORIZONTAL Y, M	HORIZONTAL Z, M
1.68753E-03	0.0122511	-2.57097E-03
ANGLE ROT. X, RAD	ANGLE ROT. Y, RAD	ANGLE ROT. Z, RAD

APPALTATORE:

Consorzio

Soci



ITINERARIO NAPOLI – BARI

PROGETTAZIONE:

Mandataria

Mandanti

RADDOPPIO TRATTA APICE – ORSARA
I LOTTO FUNZIONALE APICE – HIRPINIA

PROGETTO ESECUTIVO

RELAZIONE DI CALCOLO FONDAZIONI SPALLA A

COMMESSA
IF1NLOTTO
01 E ZZCODIFICA
RGDOCUMENTO
MD0000 001REV.
BFOGLIO
79 di 109

1.17591E-05 -1.23722E-04 -8.25963E-04

THE GLOBAL STRUCTURAL COORDINATE SYSTEM

* PILE TOP DISPLACEMENTS *

PILE GROUP	DISP. X, M	DISP. Y, M	DISP. Z, M	ROT. X,RAD	ROT. Y,RAD	ROT. Z,RAD
1	4.5692E-03	0.012172	-2.5180E-03	1.1759E-05	-1.2372E-04	-8.2596E-04
2	8.5240E-04	0.012172	-2.5710E-03	1.1759E-05	-1.2372E-04	-8.2596E-04
3	-2.8644E-03	0.012172	-2.6239E-03	1.1759E-05	-1.2372E-04	-8.2596E-04
4	5.1260E-03	0.012225	-2.5180E-03	1.1759E-05	-1.2372E-04	-8.2596E-04
5	1.4092E-03	0.012225	-2.5710E-03	1.1759E-05	-1.2372E-04	-8.2596E-04
6	-2.3077E-03	0.012225	-2.6239E-03	1.1759E-05	-1.2372E-04	-8.2596E-04
7	5.6827E-03	0.012278	-2.5180E-03	1.1759E-05	-1.2372E-04	-8.2596E-04
8	1.9659E-03	0.012278	-2.5710E-03	1.1759E-05	-1.2372E-04	-8.2596E-04
9	-1.7509E-03	0.012278	-2.6239E-03	1.1759E-05	-1.2372E-04	-8.2596E-04
10	6.2395E-03	0.012330	-2.5180E-03	1.1759E-05	-1.2372E-04	-8.2596E-04
11	2.5226E-03	0.012330	-2.5710E-03	1.1759E-05	-1.2372E-04	-8.2596E-04
12	-1.1942E-03	0.012330	-2.6239E-03	1.1759E-05	-1.2372E-04	-8.2596E-04
MINIMUM	-2.8644E-03	0.012172	-2.6239E-03	1.1759E-05	-1.2372E-04	-8.2596E-04
Pile N.	3	1	3	1	1	1
MAXIMUM	6.2395E-03	0.012330	-2.5180E-03	1.1759E-05	-1.2372E-04	-8.2596E-04
Pile N.	10	10	1	1	1	1

* PILE TOP REACTIONS *

PILE GROUP	FOR. X, KN	FOR. Y, KN	FOR. Z, KN	MOM X, KN- M	MOM Y, KN- M	MOM Z, KN- M
1	7936.8	1919.6	-428.34	3.1223	1239.3	5202.4
2	1713.3	1458.4	-336.48	3.1223	1045.0	4179.9
3	-5416.5	1481.5	-349.99	3.1223	1081.5	4207.5
4	8641.0	1829.2	-406.53	3.1223	1193.4	5026.6
5	2770.2	1313.3	-302.46	3.1223	967.47	3864.3
6	-4377.4	1328.1	-313.30	3.1223	998.08	3874.2
7	9199.3	1836.4	-405.89	3.1223	1192.5	5056.6
8	3827.1	1319.3	-302.14	3.1223	967.53	3892.6
9	-3338.4	1334.8	-313.09	3.1223	998.38	3903.7
10	9425.9	1953.1	-428.66	3.1223	1241.4	5317.3
11	4884.0	1496.0	-339.28	3.1223	1053.8	4309.2
12	-2299.3	1519.4	-352.84	3.1223	1090.4	4336.8
MINIMUM	-5416.5	1313.3	-428.66	3.1223	967.47	3864.3
Pile N.	3	5	10	1	5	5
MAXIMUM	9425.9	1953.1	-302.14	3.1223	1241.4	5317.3
Pile N.	10	10	8	1	10	10

THE PILE COORDINATE SYSTEM (LOCAL AXES)

* PILE TOP DISPLACEMENTS *

PILE GROUP	DISP. x, M	DISP. y, M	DISP. z, M	ROT. x,RAD	ROT. y,RAD	ROT. z,RAD
1	4.5692E-03	0.012172	-2.5180E-03	1.1759E-05	-1.2372E-04	-8.2596E-04
2	8.5240E-04	0.012172	-2.5710E-03	1.1759E-05	-1.2372E-04	-8.2596E-04
3	-2.8644E-03	0.012172	-2.6239E-03	1.1759E-05	-1.2372E-04	-8.2596E-04
4	5.1260E-03	0.012225	-2.5180E-03	1.1759E-05	-1.2372E-04	-8.2596E-04
5	1.4092E-03	0.012225	-2.5710E-03	1.1759E-05	-1.2372E-04	-8.2596E-04
6	-2.3077E-03	0.012225	-2.6239E-03	1.1759E-05	-1.2372E-04	-8.2596E-04
7	5.6827E-03	0.012278	-2.5180E-03	1.1759E-05	-1.2372E-04	-8.2596E-04
8	1.9659E-03	0.012278	-2.5710E-03	1.1759E-05	-1.2372E-04	-8.2596E-04
9	-1.7509E-03	0.012278	-2.6239E-03	1.1759E-05	-1.2372E-04	-8.2596E-04
10	6.2395E-03	0.012330	-2.5180E-03	1.1759E-05	-1.2372E-04	-8.2596E-04
11	2.5226E-03	0.012330	-2.5710E-03	1.1759E-05	-1.2372E-04	-8.2596E-04
12	-1.1942E-03	0.012330	-2.6239E-03	1.1759E-05	-1.2372E-04	-8.2596E-04
MINIMUM	-2.8644E-03	0.012172	-2.6239E-03	1.1759E-05	-1.2372E-04	-8.2596E-04
Pile N.	3	1	3	1	1	1
MAXIMUM	6.2395E-03	0.012330	-2.5180E-03	1.1759E-05	-1.2372E-04	-8.2596E-04
Pile N.	10	10	1	1	1	1

* PILE TOP REACTIONS *

PILE GROUP	AXIAL, KN	LAT. y, KN	LAT. z, KN	MOM x, KN- M	MOM y, KN- M	MOM z, KN- M
1	7936.8	1919.6	-428.34	3.1223	1239.3	5202.4
2	1713.3	1458.4	-336.48	3.1223	1045.0	4179.9
3	-5416.5	1481.5	-349.99	3.1223	1081.5	4207.5
4	8641.0	1829.2	-406.53	3.1223	1193.4	5026.6
5	2770.2	1313.3	-302.46	3.1223	967.47	3864.3
6	-4377.4	1328.1	-313.30	3.1223	998.08	3874.2
7	9199.3	1836.4	-405.89	3.1223	1192.5	5056.6
8	3827.1	1319.3	-302.14	3.1223	967.53	3892.6

APPALDATTORE:

Consorzio

Soci



ITINERARIO NAPOLI – BARI

PROGETTAZIONE:

Mandatario

Mandanti



**RADDOPPIO TRATTA APICE – ORSARA
I LOTTO FUNZIONALE APICE – HIRPINIA**

PROGETTO ESECUTIVO

RELAZIONE DI CALCOLO FONDAZIONI SPALLA A

COMMESSA IF1N	LOTTO 01 E ZZ	CODIFICA RG	DOCUMENTO MD0000 001	REV. B	FOGLIO 80 di 109
------------------	------------------	----------------	-------------------------	-----------	---------------------

9	-3338.4	1334.8	-313.09	3.1223	998.38	3903.7
10	9425.9	1953.1	-428.66	3.1223	1241.4	5317.3
11	4884.0	1496.0	-339.28	3.1223	1053.8	4309.2
12	-2299.3	1519.4	-352.84	3.1223	1090.4	4336.8
MINIMUM	-5416.5	1313.3	-428.66	3.1223	967.47	3864.3
Pile N.	3	5	10	1	5	5
MAXIMUM	9425.9	1953.1	-302.14	3.1223	1241.4	5317.3
Pile N.	10	10	8	1	10	10

PILE GROUP STRESS, KN/ M**2

*****	*****
1	2.0632E+04
2	1.3973E+04
3	1.6176E+04
4	2.0482E+04
5	1.3590E+04
6	1.4551E+04
7	2.0885E+04
8	1.4271E+04
9	1.4050E+04
10	2.1813E+04
11	1.6152E+04
12	1.4797E+04
MINIMUM	1.3590E+04
Pile N.	5
MAXIMUM	2.1813E+04
Pile N.	10

* EFFECTS FOR LATERALLY LOADED PILE *

* MINIMUM VALUES AND LOCATIONS *

PILE	DISPL. y-DIR M	DISPL. z-DIR M	MOMENT z-DIR KN- M	MOMENT y-DIR KN- M	SHEAR y-DIR KN	SHEAR z-DIR KN	SOIL REACT y-DIR KN/ M	SOIL REACT z-DIR KN/ M	TOTAL STRESS KN/ M**2	FLEX. RIG. z-DIR KN- M**2	FLEX. RIG. y-DIR KN- M**2
*****	*****	*****	*****	*****	*****	*****	*****	*****	*****	*****	*****
1	-6.6645E-05	-2.5181E-03	-5202.4	-483.08	-567.37	-428.51	-181.39	-85.584	4491.3	7.8279E+06	7.8279E+06
x(M)	12.150	0.0000	0.0000	7.0200	10.800	0.0000	12.150	4.3200	27.000	0.0000	0.0000
2	-8.1924E-05	-2.5710E-03	-4179.9	-415.78	-488.30	-336.51	-136.91	-61.582	969.51	7.8279E+06	7.8279E+06
x(M)	12.960	0.0000	0.0000	7.8300	11.340	0.0000	12.960	4.3200	27.000	0.0000	0.0000
3	-8.0676E-05	-2.6239E-03	-4207.5	-425.79	-489.10	-349.89	-137.89	-63.869	3065.1	7.8279E+06	7.8279E+06
x(M)	12.960	0.0000	0.0000	7.8300	11.340	0.0000	12.960	4.3200	27.000	0.0000	0.0000
4	-7.0333E-05	-2.5181E-03	-5026.6	-467.29	-559.19	-406.71	-173.59	-80.101	4889.8	7.8279E+06	7.8279E+06
x(M)	12.150	0.0000	0.0000	7.2900	10.800	0.0000	12.420	4.3200	27.000	0.0000	0.0000
5	-8.9511E-05	-2.5710E-03	-3864.3	-391.71	-459.93	-302.51	-122.42	-58.265	1567.6	7.8279E+06	7.8279E+06
x(M)	13.230	0.0000	0.0000	8.1000	11.610	0.0000	13.230	10.260	27.000	0.0000	0.0000
6	-8.8576E-05	-2.6239E-03	-3874.2	-399.97	-459.45	-313.22	-122.64	-60.299	2477.1	7.8279E+06	7.8279E+06
x(M)	13.230	0.0000	0.0000	8.1000	11.610	0.0000	13.230	10.260	27.000	0.0000	0.0000
7	-7.0778E-05	-2.5181E-03	-5056.6	-467.13	-562.06	-406.08	-174.43	-80.019	5205.7	7.8279E+06	7.8279E+06
x(M)	12.150	0.0000	0.0000	7.2900	10.800	0.0000	12.420	4.3200	27.000	0.0000	0.0000
8	-9.0035E-05	-2.5710E-03	-3892.6	-391.91	-462.65	-302.20	-123.16	-58.201	2165.7	7.8279E+06	7.8279E+06
x(M)	13.230	0.0000	0.0000	8.1000	11.610	0.0000	13.230	10.260	27.000	0.0000	0.0000
9	-8.9062E-05	-2.6239E-03	-3903.7	-400.25	-462.25	-313.03	-123.42	-60.243	1889.1	7.8279E+06	7.8279E+06
x(M)	13.230	0.0000	0.0000	8.1000	11.610	0.0000	13.230	10.260	27.000	0.0000	0.0000
10	-6.7557E-05	-2.5181E-03	-5317.3	-484.19	-577.22	-428.86	-184.86	-85.904	5334.0	7.8279E+06	7.8279E+06
x(M)	12.150	0.0000	0.0000	7.0200	10.800	0.0000	12.150	4.3200	27.000	0.0000	0.0000
11	-8.2297E-05	-2.5710E-03	-4309.2	-419.11	-499.76	-339.37	-140.95	-62.559	2763.8	7.8279E+06	7.8279E+06
x(M)	12.960	0.0000	0.0000	7.8300	11.340	0.0000	12.960	4.3200	27.000	0.0000	0.0000
12	-8.1114E-05	-2.6239E-03	-4336.8	-429.15	-500.33	-352.80	-141.86	-64.863	1301.1	7.8279E+06	7.8279E+06
x(M)	12.690	0.0000	0.0000	7.8300	11.340	0.0000	12.960	4.3200	27.000	0.0000	0.0000
Min.	-9.0035E-05	-2.6239E-03	-5317.3	-484.19	-577.22	-428.86	-184.86	-85.904	969.51	7.8279E+06	7.8279E+06
Pile N.	8	3	10	10	10	10	10	10	2	1	1

* MAXIMUM VALUES AND LOCATIONS *

PILE	DISPL. y-DIR M	DISPL. z-DIR M	MOMENT z-DIR KN- M	MOMENT y-DIR KN- M	SHEAR y-DIR KN	SHEAR z-DIR KN	SOIL REACT y-DIR KN/ M	SOIL REACT z-DIR KN/ M	TOTAL STRESS KN/ M**2	FLEX. RIG. z-DIR KN- M**2	FLEX. RIG. y-DIR KN- M**2
*****	*****	*****	*****	*****	*****	*****	*****	*****	*****	*****	*****
1	0.012172	1.4572E-05	2305.3	1239.3	1920.3	124.25	392.37	39.670	2.0632E+04	7.8279E+06	7.8279E+06
x(M)	0.0000	12.150	6.7500	0.0000	0.0000	10.800	4.3200	12.420	0.0000	0.0000	0.0000
2	0.012172	1.8518E-05	1934.5	1045.0	1458.5	109.86	275.39	31.019	1.3973E+04	7.8279E+06	7.8279E+06
x(M)	0.0000	12.960	7.5600	0.0000	0.0000	11.340	4.3200	13.230	0.0000	0.0000	0.0000
3	0.012172	1.8678E-05	1939.2	1081.5	1481.1	112.68	279.15	31.976	1.6176E+04	7.8279E+06	7.8279E+06
x(M)	0.0000	12.960	7.5600	0.0000	0.0000	11.340	4.3200	13.230	0.0000	0.0000	0.0000
4	0.012225	1.5258E-05	2240.8	1193.4	1829.9	121.35	369.06	38.036	2.0482E+04	7.8279E+06	7.8279E+06
x(M)	0.0000	12.150	7.0200	0.0000	0.0000	10.800	4.3200	12.420	0.0000	0.0000	0.0000
5	0.012225	2.0117E-05	1825.6	967.47	1313.5	103.28	239.96	27.689	1.3590E+04	7.8279E+06	7.8279E+06
x(M)	0.0000	13.230	7.8300	0.0000	0.0000	11.610	4.3200	13.500	0.0000	0.0000	0.0000
6	0.012225	2.0384E-05	1824.3	998.08	1327.9	105.60	241.95	28.414	1.4551E+04	7.8279E+06	7.8279E+06
x(M)	0.0000	13.230	7.8300	0.0000	0.0000	11.610	10.260	13.500	0.0000	0.0000	0.0000
7	0.012278	1.5276E-05	2250.1	1192.5	1837.2	121.34	370.58	38.017	2.0885E+04	7.8279E+06	7.8279E+06
x(M)	0.0000	12.150	7.0200	0.0000	0.0000	10.800	4.3200	12.420	0.0000	0.0000	0.0000
8	0.012278	2.0129E-05	1834.9	967.53	1319.6	103.35	241.18	27.703	1.4271E+04	7.8279E+06	7.8279E+06
x(M)	0.0000	13.230	7.8300	0.0000	0.0000	11.610	4.3200	13.500	0.0000	0.0000	0.0000

APPALTATORE: Consorzio Soci   	ITINERARIO NAPOLI – BARI RADDOPPIO TRATTA APICE – ORSARA I LOTTO FUNZIONALE APICE – HIRPINIA				
PROGETTAZIONE: Mandataria Mandanti   					
PROGETTO ESECUTIVO RELAZIONE DI CALCOLO FONDAZIONI SPALLA A					
COMMESSA IF1N	LOTTO 01 E ZZ	CODIFICA RG	DOCUMENTO MD0000 001	REV. B	FOGLIO 81 di 109

9	0.012278	2.0388E-05	1834.0	998.38	1334.5	105.69	243.26	28.438	1.4050E+04	7.8279E+06	7.8279E+06
x(M)	0.0000	13.230	7.8300	0.0000	0.0000	11.610	10.260	13.500	0.0000	0.0000	0.0000
10	0.012330	1.4546E-05	2341.7	1241.4	1954.0	124.48	399.99	39.803	2.1813E+04	7.8279E+06	7.8279E+06
x(M)	0.0000	12.150	6.7500	0.0000	0.0000	10.800	4.3200	12.150	0.0000	0.0000	0.0000
11	0.012330	1.8320E-05	1977.3	1053.8	1496.4	110.81	284.15	31.377	1.6152E+04	7.8279E+06	7.8279E+06
x(M)	0.0000	12.960	7.5600	0.0000	0.0000	11.340	4.3200	12.960	0.0000	0.0000	0.0000
12	0.012330	1.8473E-05	1981.9	1090.4	1519.2	113.58	287.94	32.342	1.4797E+04	7.8279E+06	7.8279E+06
x(M)	0.0000	12.960	7.5600	0.0000	0.0000	11.340	4.3200	12.960	0.0000	0.0000	0.0000
Max.	0.012330	2.0388E-05	2341.7	1241.4	1954.0	124.48	399.99	39.803	2.1813E+04	7.8279E+06	7.8279E+06
Pile N.	10	9	10	10	10	10	10	10	10	1	1

LOAD CASE : 10
CASE NAME : Load Case
LOAD TYPE : Special, Sp

REDUCTION FACTORS FOR CLOSELY-SPACED PILE GROUPS, COMBINED Y AND Z DIRECTIONS
ESTIMATED USING MOVEMENT IN THE DIRECTION OF PILE CAP DISPLACEMENTS

GROUP NO	P-FACTOR	Y-FACTOR
1	0.6004	1.0000
2	0.5914	1.0000
3	0.8661	1.0000
4	0.4997	1.0000
5	0.4952	1.0000
6	0.7963	1.0000
7	0.4979	1.0000
8	0.4936	1.0000
9	0.7951	1.0000
10	0.5845	1.0000
11	0.5755	1.0000
12	0.8551	1.0000

* TABLE L * COMPUTATION ON PILE CAP

* EQUIVALENT CONCENTRATED LOAD AT ORIGIN *

VERT. LOAD, KN	HOR. LOAD Y, KN	HOR. LOAD Z, KN
40273.0	-17902.5	4217.40
MOMENT X, KN- M	MOMENT Y, KN- M	MOMENT Z, KN- M
656.000	46241.8	1.58806E+05

* DISPLACEMENT OF GROUPED PILE FOUNDATION AT ORIGIN *

VERTICAL, M	HORIZONTAL Y, M	HORIZONTAL Z, M
2.02718E-03	-0.0112945	2.48443E-03
ANGLE ROT. X, RAD	ANGLE ROT. Y, RAD	ANGLE ROT. Z, RAD
3.16456E-05	1.25887E-04	7.68267E-04

THE GLOBAL STRUCTURAL COORDINATE SYSTEM

* PILE TOP DISPLACEMENTS *

PILE GROUP	DISP. X, M	DISP. Y, M	DISP. Z, M	ROT. X, RAD	ROT. Y, RAD	ROT. Z, RAD
1	-5.8029E-04	-0.011508	2.6268E-03	3.1646E-05	1.2589E-04	7.6827E-04
2	2.8769E-03	-0.011508	2.4844E-03	3.1646E-05	1.2589E-04	7.6827E-04
3	6.3341E-03	-0.011508	2.3420E-03	3.1646E-05	1.2589E-04	7.6827E-04
4	-1.1468E-03	-0.011366	2.6268E-03	3.1646E-05	1.2589E-04	7.6827E-04
5	2.3104E-03	-0.011366	2.4844E-03	3.1646E-05	1.2589E-04	7.6827E-04
6	5.7676E-03	-0.011366	2.3420E-03	3.1646E-05	1.2589E-04	7.6827E-04
7	-1.7133E-03	-0.011223	2.6268E-03	3.1646E-05	1.2589E-04	7.6827E-04
8	1.7439E-03	-0.011223	2.4844E-03	3.1646E-05	1.2589E-04	7.6827E-04
9	5.2011E-03	-0.011223	2.3420E-03	3.1646E-05	1.2589E-04	7.6827E-04
10	-2.2798E-03	-0.011081	2.6268E-03	3.1646E-05	1.2589E-04	7.6827E-04
11	1.1774E-03	-0.011081	2.4844E-03	3.1646E-05	1.2589E-04	7.6827E-04
12	4.6346E-03	-0.011081	2.3420E-03	3.1646E-05	1.2589E-04	7.6827E-04
MINIMUM	-2.2798E-03	-0.011508	2.3420E-03	3.1646E-05	1.2589E-04	7.6827E-04
Pile N.	10	1	3	1	1	1
MAXIMUM	6.3341E-03	-0.011081	2.6268E-03	3.1646E-05	1.2589E-04	7.6827E-04
Pile N.	3	10	1	1	1	1

* PILE TOP REACTIONS *

APPALTATORE:

Consorzio

Soci



ITINERARIO NAPOLI – BARI

PROGETTAZIONE:

Mandataria

Mandanti



**RADDOPPIO TRATTA APICE – ORSARA
I LOTTO FUNZIONALE APICE – HIRPINIA**

PROGETTO ESECUTIVO

RELAZIONE DI CALCOLO FONDAZIONI SPALLA A

COMMESSA IF1N	LOTTO 01 E ZZ	CODIFICA RG	DOCUMENTO MD0000 001	REV. B	FOGLIO 82 di 109
------------------	------------------	----------------	-------------------------	-----------	---------------------

PILE GROUP *****	FOR. X, KN *****	FOR. Y, KN *****	FOR. Z, KN *****	MOM X, KN- M *****	MOM Y, KN- M *****	MOM Z, KN- M *****
1	-1150.4	-1462.3	362.31	8.4026	-1106.7	-4146.0
2	5556.6	-1441.4	334.09	8.4026	-1018.5	-4120.9
3	9464.4	-1882.6	403.68	8.4026	-1140.5	-5082.2
4	-2210.8	-1274.2	322.20	8.4026	-1014.7	-3690.1
5	4481.2	-1260.7	298.06	8.4026	-935.68	-3680.5
6	9233.9	-1757.2	383.26	8.4026	-1096.9	-4783.1
7	-3268.1	-1258.7	323.57	8.4026	-1016.9	-3622.3
8	3405.7	-1245.9	299.47	8.4026	-938.01	-3614.0
9	8736.1	-1738.5	385.33	8.4026	-1100.6	-4707.4
10	-4325.3	-1394.3	362.93	8.4026	-1105.1	-3892.5
11	2330.3	-1374.1	334.64	8.4026	-1016.9	-3868.3
12	8019.5	-1812.6	407.84	8.4026	-1147.4	-4824.9
MINIMUM	-4325.3	-1882.6	298.06	8.4026	-1147.4	-5082.2
Pile N.	10	3	5	1	12	3
MAXIMUM	9464.4	-1245.9	407.84	8.4026	-935.68	-3614.0
Pile N.	3	8	12	1	5	8

THE PILE COORDINATE SYSTEM (LOCAL AXES)

* PILE TOP DISPLACEMENTS *

PILE GROUP *****	DISP. x, M *****	DISP. y, M *****	DISP. z, M *****	ROT. x,RAD *****	ROT. y,RAD *****	ROT. z,RAD *****
1	-5.8029E-04	-0.011508	2.6268E-03	3.1646E-05	1.2589E-04	7.6827E-04
2	2.8769E-03	-0.011508	2.4844E-03	3.1646E-05	1.2589E-04	7.6827E-04
3	6.3341E-03	-0.011508	2.3420E-03	3.1646E-05	1.2589E-04	7.6827E-04
4	-1.1468E-03	-0.011366	2.6268E-03	3.1646E-05	1.2589E-04	7.6827E-04
5	2.3104E-03	-0.011366	2.4844E-03	3.1646E-05	1.2589E-04	7.6827E-04
6	5.7676E-03	-0.011366	2.3420E-03	3.1646E-05	1.2589E-04	7.6827E-04
7	-1.7133E-03	-0.011223	2.6268E-03	3.1646E-05	1.2589E-04	7.6827E-04
8	1.7439E-03	-0.011223	2.4844E-03	3.1646E-05	1.2589E-04	7.6827E-04
9	5.2011E-03	-0.011223	2.3420E-03	3.1646E-05	1.2589E-04	7.6827E-04
10	-2.2798E-03	-0.011081	2.6268E-03	3.1646E-05	1.2589E-04	7.6827E-04
11	1.1774E-03	-0.011081	2.4844E-03	3.1646E-05	1.2589E-04	7.6827E-04
12	4.6346E-03	-0.011081	2.3420E-03	3.1646E-05	1.2589E-04	7.6827E-04
MINIMUM	-2.2798E-03	-0.011508	2.3420E-03	3.1646E-05	1.2589E-04	7.6827E-04
Pile N.	10	1	3	1	1	1
MAXIMUM	6.3341E-03	-0.011081	2.6268E-03	3.1646E-05	1.2589E-04	7.6827E-04
Pile N.	3	10	1	1	1	1

* PILE TOP REACTIONS *

PILE GROUP *****	AXIAL, KN *****	LAT. y, KN *****	LAT. z, KN *****	MOM x, KN- M *****	MOM y, KN- M *****	MOM z, KN- M *****
1	-1150.4	-1462.3	362.31	8.4026	-1106.7	-4146.0
2	5556.6	-1441.4	334.09	8.4026	-1018.5	-4120.9
3	9464.4	-1882.6	403.68	8.4026	-1140.5	-5082.2
4	-2210.8	-1274.2	322.20	8.4026	-1014.7	-3690.1
5	4481.2	-1260.7	298.06	8.4026	-935.68	-3680.5
6	9233.9	-1757.2	383.26	8.4026	-1096.9	-4783.1
7	-3268.1	-1258.7	323.57	8.4026	-1016.9	-3622.3
8	3405.7	-1245.9	299.47	8.4026	-938.01	-3614.0
9	8736.1	-1738.5	385.33	8.4026	-1100.6	-4707.4
10	-4325.3	-1394.3	362.93	8.4026	-1105.1	-3892.5
11	2330.3	-1374.1	334.64	8.4026	-1016.9	-3868.3
12	8019.5	-1812.6	407.84	8.4026	-1147.4	-4824.9
MINIMUM	-4325.3	-1882.6	298.06	8.4026	-1147.4	-5082.2
Pile N.	10	3	5	1	12	3
MAXIMUM	9464.4	-1245.9	407.84	8.4026	-935.68	-3614.0
Pile N.	3	8	12	1	5	8

PILE GROUP STRESS, KN/ M**2

PILE GROUP *****	STRESS, KN/ M**2 *****
1	1.3602E+04
2	1.5956E+04
3	2.1076E+04
4	1.2801E+04
5	1.3997E+04
6	2.0036E+04
7	1.3204E+04
8	1.3196E+04
9	1.9534E+04
10	1.4660E+04
11	1.3390E+04
12	1.9506E+04
MINIMUM	1.2801E+04
Pile N.	4
MAXIMUM	2.1076E+04
Pile N.	3

APPALTATORE: Consorzio Soci   		ITINERARIO NAPOLI – BARI RADDOPPIO TRATTA APICE – ORSARA I LOTTO FUNZIONALE APICE – HIRPINIA					
PROGETTAZIONE: Mandataria Mandanti   							
PROGETTO ESECUTIVO RELAZIONE DI CALCOLO FONDAZIONI SPALLA A		COMMESSA IF1N	LOTTO 01 E ZZ	CODIFICA RG	DOCUMENTO MD0000 001	REV. B	FOGLIO 83 di 109

* EFFECTS FOR LATERALLY LOADED PILE *

* MINIMUM VALUES AND LOCATIONS *

PILE	DISPL. y-DIR M	DISPL. z-DIR M	MOMENT z-DIR KN- M	MOMENT y-DIR KN- M	SHEAR y-DIR KN	SHEAR z-DIR KN	SOIL REACT y-DIR KN/ M	SOIL REACT z-DIR KN/ M	TOTAL STRESS KN/ M**2	FLEX. RIG. z-DIR KN- M**2	FLEX. RIG. y-DIR KN- M**2
*****	*****	*****	*****	*****	*****	*****	*****	*****	*****	*****	*****
1	-0.011508	-1.7998E-05	-1877.6	-1106.7	-1462.2	-114.64	-277.35	-33.038	651.00	7.8279E+06	7.8279E+06
x(M)	0.0000	12.690	7.2900	0.0000	0.0000	11.340	4.3200	12.960	27.000	0.0000	0.0000
2	-0.011508	-1.7111E-05	-1872.9	-1018.5	-1441.8	-107.34	-273.87	-30.766	3144.4	7.8279E+06	7.8279E+06
x(M)	0.0000	12.690	7.5600	0.0000	0.0000	11.340	4.3200	12.960	27.000	0.0000	0.0000
3	-0.011508	-1.3078E-05	-2222.5	-1140.5	-1883.5	-115.10	-384.91	-37.453	5355.8	7.8279E+06	7.8279E+06
x(M)	0.0000	11.880	6.7500	0.0000	0.0000	10.800	4.3200	12.150	27.000	0.0000	0.0000
4	-0.011366	-1.9896E-05	-1723.4	-1014.7	-1274.0	-106.95	-232.89	-29.056	1251.1	7.8279E+06	7.8279E+06
x(M)	0.0000	13.230	7.8300	0.0000	0.0000	11.610	4.3200	13.500	27.000	0.0000	0.0000
5	-0.011366	-1.8844E-05	-1724.3	-935.68	-1261.0	-100.33	-231.21	-27.154	2535.8	7.8279E+06	7.8279E+06
x(M)	0.0000	13.230	7.8300	0.0000	0.0000	11.610	4.3200	13.500	27.000	0.0000	0.0000
6	-0.011366	-1.3682E-05	-2118.2	-1096.9	-1758.0	-112.55	-354.37	-35.538	5225.3	7.8279E+06	7.8279E+06
x(M)	0.0000	12.150	7.0200	0.0000	0.0000	10.800	4.3200	12.420	27.000	0.0000	0.0000
7	-0.011223	-1.9848E-05	-1702.4	-1016.9	-1258.5	-107.06	-230.12	-29.122	1849.4	7.8279E+06	7.8279E+06
x(M)	0.0000	13.230	7.8300	0.0000	0.0000	11.610	4.3200	13.500	27.000	0.0000	0.0000
8	-0.011223	-1.8791E-05	-1703.6	-938.01	-1246.1	-100.45	-228.59	-27.236	1927.3	7.8279E+06	7.8279E+06
x(M)	0.0000	13.230	7.8300	0.0000	0.0000	11.610	4.3200	13.230	27.000	0.0000	0.0000
9	-0.011223	-1.3636E-05	-2095.9	-1100.6	-1739.2	-112.73	-350.83	-35.654	4943.6	7.8279E+06	7.8279E+06
x(M)	0.0000	12.150	7.0200	0.0000	0.0000	10.800	4.3200	12.420	27.000	0.0000	0.0000
10	-0.011081	-1.8025E-05	-1800.1	-1105.1	-1394.0	-114.31	-263.72	-32.904	2447.6	7.8279E+06	7.8279E+06
x(M)	0.0000	12.690	7.2900	0.0000	0.0000	11.340	4.3200	12.960	27.000	0.0000	0.0000
11	-0.011081	-1.7142E-05	-1795.3	-1016.9	-1374.3	-107.02	-260.35	-30.637	1318.7	7.8279E+06	7.8279E+06
x(M)	0.0000	12.960	7.2900	0.0000	0.0000	11.340	4.3200	12.960	27.000	0.0000	0.0000
12	-0.011081	-1.3080E-05	-2146.7	-1147.4	-1813.3	-115.40	-370.67	-37.749	4538.1	7.8279E+06	7.8279E+06
x(M)	0.0000	11.880	6.7500	0.0000	0.0000	10.800	4.3200	12.150	27.000	0.0000	0.0000
Min. Pile N.	-0.011508 1	-1.9896E-05 4	-2222.5 3	-1147.4 12	-1883.5 3	-115.40 12	-384.91 3	-37.749 12	651.00 1	7.8279E+06 1	7.8279E+06 1

* MAXIMUM VALUES AND LOCATIONS *

PILE	DISPL. y-DIR M	DISPL. z-DIR M	MOMENT z-DIR KN- M	MOMENT y-DIR KN- M	SHEAR y-DIR KN	SHEAR z-DIR KN	SOIL REACT y-DIR KN/ M	SOIL REACT z-DIR KN/ M	TOTAL STRESS KN/ M**2	FLEX. RIG. z-DIR KN- M**2	FLEX. RIG. y-DIR KN- M**2
*****	*****	*****	*****	*****	*****	*****	*****	*****	*****	*****	*****
1	7.4451E-05	2.6268E-03	4146.0	435.29	471.57	362.29	135.47	66.824	1.3602E+04	7.8279E+06	7.8279E+06
x(M)	12.690	0.0000	0.0000	7.5600	11.340	0.0000	12.960	4.3200	0.0000	0.0000	0.0000
2	7.5475E-05	2.4844E-03	4120.9	409.71	471.11	334.19	134.67	61.937	1.5956E+04	7.8279E+06	7.8279E+06
x(M)	12.690	0.0000	0.0000	7.5600	11.340	0.0000	12.960	4.3200	0.0000	0.0000	0.0000
3	6.2286E-05	2.3420E-03	5082.2	456.02	546.36	403.87	176.86	81.276	2.1076E+04	7.8279E+06	7.8279E+06
x(M)	11.880	0.0000	0.0000	7.0200	10.530	0.0000	12.150	4.3200	0.0000	0.0000	0.0000
4	8.0407E-05	2.6268E-03	3690.1	406.24	432.34	322.16	117.30	60.410	1.2801E+04	7.8279E+06	7.8279E+06
x(M)	13.230	0.0000	0.0000	8.1000	11.610	0.0000	13.230	10.260	0.0000	0.0000	0.0000
5	8.1270E-05	2.4844E-03	3680.5	383.10	432.69	298.13	117.10	55.654	1.3997E+04	7.8279E+06	7.8279E+06
x(M)	13.230	0.0000	0.0000	8.1000	11.610	0.0000	13.230	10.260	0.0000	0.0000	0.0000
6	6.3795E-05	2.3420E-03	4783.1	440.44	524.51	383.43	164.96	75.962	2.0036E+04	7.8279E+06	7.8279E+06
x(M)	12.150	0.0000	0.0000	7.0200	10.800	0.0000	12.150	4.3200	0.0000	0.0000	0.0000
7	7.8987E-05	2.6268E-03	3622.3	406.69	425.99	323.51	115.78	60.570	1.3204E+04	7.8279E+06	7.8279E+06
x(M)	12.960	0.0000	0.0000	8.1000	11.610	0.0000	13.230	10.260	0.0000	0.0000	0.0000
8	7.9835E-05	2.4844E-03	3614.0	383.60	426.40	299.53	115.63	55.810	1.3196E+04	7.8279E+06	7.8279E+06
x(M)	12.960	0.0000	0.0000	8.1000	11.610	0.0000	13.230	10.260	0.0000	0.0000	0.0000
9	6.2615E-05	2.3420E-03	4707.4	441.63	517.31	385.49	163.14	76.346	1.9534E+04	7.8279E+06	7.8279E+06
x(M)	12.150	0.0000	0.0000	7.0200	10.800	0.0000	12.150	4.3200	0.0000	0.0000	0.0000
10	7.1257E-05	2.6268E-03	3892.5	434.04	448.97	362.85	128.77	66.492	1.4660E+04	7.8279E+06	7.8279E+06
x(M)	12.690	0.0000	0.0000	7.8300	11.340	0.0000	12.960	4.3200	0.0000	0.0000	0.0000
11	7.2235E-05	2.4844E-03	3868.3	408.46	448.48	334.68	127.98	61.616	1.3390E+04	7.8279E+06	7.8279E+06
x(M)	12.690	0.0000	0.0000	7.5600	11.340	0.0000	12.960	4.3200	0.0000	0.0000	0.0000
12	5.9572E-05	2.3420E-03	4824.9	457.91	526.22	408.00	170.20	81.891	1.9506E+04	7.8279E+06	7.8279E+06
x(M)	11.880	0.0000	0.0000	7.0200	10.530	0.0000	12.150	4.3200	0.0000	0.0000	0.0000
Max. Pile N.	8.1270E-05 5	2.6268E-03 1	5082.2 3	457.91 12	546.36 3	408.00 12	176.86 3	81.891 12	2.1076E+04 3	7.8279E+06 1	7.8279E+06 1

LOAD CASE : 11
CASE NAME : Load Case
LOAD TYPE : Special, Sp

REDUCTION FACTORS FOR CLOSELY-SPACED PILE GROUPS, COMBINED Y AND Z DIRECTIONS
ESTIMATED USING MOVEMENT IN THE DIRECTION OF PILE CAP DISPLACEMENTS

GROUP NO	P-FACTOR	Y-FACTOR
1	0.8504	1.0000
2	0.5740	1.0000
3	0.5845	1.0000
4	0.7908	1.0000
5	0.4930	1.0000
6	0.4989	1.0000
7	0.7924	1.0000

APPALTATORE: Consorzio Soci   	ITINERARIO NAPOLI – BARI RADDOPPIO TRATTA APICE – ORSARA I LOTTO FUNZIONALE APICE – HIRPINIA
PROGETTAZIONE: Mandataria Mandanti   	
PROGETTO ESECUTIVO RELAZIONE DI CALCOLO FONDAZIONI SPALLA A	COMMESSA LOTTO CODIFICA DOCUMENTO REV. FOGLIO IF1N 01 E ZZ RG MD0000 001 B 84 di 109

8	0.4952	1.0000
9	0.5015	1.0000
10	0.8661	1.0000
11	0.5966	1.0000
12	0.6071	1.0000

* TABLE L * COMPUTATION ON PILE CAP

* EQUIVALENT CONCENTRATED LOAD AT ORIGIN *

VERT. LOAD, KN	HOR. LOAD Y, KN	HOR. LOAD Z, KN
56653.3	5158.00	-1498.00
MOMENT X, KN- M	MOMENT Y, KN- M	MOMENT Z, KN- M
-716.000	-24450.0	-61609.0

* DISPLACEMENT OF GROUPED PILE FOUNDATION AT ORIGIN *

VERTICAL, M	HORIZONTAL Y, M	HORIZONTAL Z, M
2.47314E-03	1.95722E-03	-5.19897E-04
ANGLE ROT. X, RAD	ANGLE ROT. Y, RAD	ANGLE ROT. Z, RAD
-1.84463E-06	-5.34183E-05	-2.43791E-04

THE GLOBAL STRUCTURAL COORDINATE SYSTEM

* PILE TOP DISPLACEMENTS *

PILE GROUP	DISP. X, M	DISP. Y, M	DISP. Z, M	ROT. X, RAD	ROT. Y, RAD	ROT. Z, RAD
*****	*****	*****	*****	*****	*****	*****
1	3.2096E-03	1.9697E-03	-5.2820E-04	-1.8446E-06	-5.3418E-05	-2.4379E-04
2	2.1126E-03	1.9697E-03	-5.1990E-04	-1.8446E-06	-5.3418E-05	-2.4379E-04
3	1.0155E-03	1.9697E-03	-5.1160E-04	-1.8446E-06	-5.3418E-05	-2.4379E-04
4	3.4500E-03	1.9614E-03	-5.2820E-04	-1.8446E-06	-5.3418E-05	-2.4379E-04
5	2.3529E-03	1.9614E-03	-5.1990E-04	-1.8446E-06	-5.3418E-05	-2.4379E-04
6	1.2559E-03	1.9614E-03	-5.1160E-04	-1.8446E-06	-5.3418E-05	-2.4379E-04
7	3.6904E-03	1.9531E-03	-5.2820E-04	-1.8446E-06	-5.3418E-05	-2.4379E-04
8	2.5933E-03	1.9531E-03	-5.1990E-04	-1.8446E-06	-5.3418E-05	-2.4379E-04
9	1.4963E-03	1.9531E-03	-5.1160E-04	-1.8446E-06	-5.3418E-05	-2.4379E-04
10	3.9308E-03	1.9448E-03	-5.2820E-04	-1.8446E-06	-5.3418E-05	-2.4379E-04
11	2.8337E-03	1.9448E-03	-5.1990E-04	-1.8446E-06	-5.3418E-05	-2.4379E-04
12	1.7367E-03	1.9448E-03	-5.1160E-04	-1.8446E-06	-5.3418E-05	-2.4379E-04
MINIMUM	1.0155E-03	1.9448E-03	-5.2820E-04	-1.8446E-06	-5.3418E-05	-2.4379E-04
Pile N.	3	10	1	1	1	1
MAXIMUM	3.9308E-03	1.9697E-03	-5.1160E-04	-1.8446E-06	-5.3418E-05	-2.4379E-04
Pile N.	10	1	3	1	1	1



* PILE TOP REACTIONS *

PILE GROUP	FOR. X, KN	FOR. Y, KN	FOR. Z, KN	MOM X, KN- M	MOM Y, KN- M	MOM Z, KN- M
*****	*****	*****	*****	*****	*****	*****
1	6188.2	535.89	-156.11	-0.4898	316.62	987.59
2	4105.6	403.14	-116.05	-0.4898	245.23	763.61
3	2022.9	409.27	-115.11	-0.4898	240.53	773.04
4	6521.0	506.11	-148.63	-0.4898	304.36	936.27
5	4561.9	358.42	-104.29	-0.4898	224.15	681.90
6	2479.3	362.25	-102.97	-0.4898	218.85	687.51
7	6825.0	504.49	-149.07	-0.4898	305.16	930.70
8	5018.2	357.77	-104.78	-0.4898	225.13	678.47
9	2935.6	361.80	-103.50	-0.4898	219.91	684.42
10	7129.1	535.49	-158.86	-0.4898	321.31	977.94
11	5474.6	408.70	-119.83	-0.4898	252.17	765.95
12	3391.9	414.67	-118.79	-0.4898	247.27	774.99
MINIMUM	2022.9	357.77	-158.86	-0.4898	218.85	678.47
Pile N.	3	8	10	1	6	8
MAXIMUM	7129.1	535.89	-102.97	-0.4898	321.31	987.59
Pile N.	10	1	6	1	10	1

THE PILE COORDINATE SYSTEM (LOCAL AXES)

* PILE TOP DISPLACEMENTS *

PILE GROUP	DISP. x, M	DISP. y, M	DISP. z, M	ROT. x, RAD	ROT. y, RAD	ROT. z, RAD
*****	*****	*****	*****	*****	*****	*****
1	3.2096E-03	1.9697E-03	-5.2820E-04	-1.8446E-06	-5.3418E-05	-2.4379E-04
2	2.1126E-03	1.9697E-03	-5.1990E-04	-1.8446E-06	-5.3418E-05	-2.4379E-04

APPALTATORE: Consorzio  Soci  		ITINERARIO NAPOLI – BARI					
PROGETTAZIONE: Mandataria  Mandanti  		RADDOPPIO TRATTA APICE – ORSARA I LOTTO FUNZIONALE APICE – HIRPINIA					
PROGETTO ESECUTIVO RELAZIONE DI CALCOLO FONDAZIONI SPALLA A		COMMESSA IF1N	LOTTO 01 E ZZ	CODIFICA RG	DOCUMENTO MD0000 001	REV. B	FOGLIO 85 di 109

3	1.0155E-03	1.9697E-03	-5.1160E-04	-1.8446E-06	-5.3418E-05	-2.4379E-04
4	3.4500E-03	1.9614E-03	-5.2820E-04	-1.8446E-06	-5.3418E-05	-2.4379E-04
5	2.3529E-03	1.9614E-03	-5.1990E-04	-1.8446E-06	-5.3418E-05	-2.4379E-04
6	1.2559E-03	1.9614E-03	-5.1160E-04	-1.8446E-06	-5.3418E-05	-2.4379E-04
7	3.6904E-03	1.9531E-03	-5.2820E-04	-1.8446E-06	-5.3418E-05	-2.4379E-04
8	2.5933E-03	1.9531E-03	-5.1990E-04	-1.8446E-06	-5.3418E-05	-2.4379E-04
9	1.4963E-03	1.9531E-03	-5.1160E-04	-1.8446E-06	-5.3418E-05	-2.4379E-04
10	3.9308E-03	1.9448E-03	-5.2820E-04	-1.8446E-06	-5.3418E-05	-2.4379E-04
11	2.8337E-03	1.9448E-03	-5.1990E-04	-1.8446E-06	-5.3418E-05	-2.4379E-04
12	1.7367E-03	1.9448E-03	-5.1160E-04	-1.8446E-06	-5.3418E-05	-2.4379E-04

MINIMUM	1.0155E-03	1.9448E-03	-5.2820E-04	-1.8446E-06	-5.3418E-05	-2.4379E-04
Pile N.	3	10	1	1	1	1
MAXIMUM	3.9308E-03	1.9697E-03	-5.1160E-04	-1.8446E-06	-5.3418E-05	-2.4379E-04
Pile N.	10	1	3	1	1	1

* PILE TOP REACTIONS *

PILE GROUP	AXIAL, KN	LAT. y, KN	LAT. z, KN	MOM x, KN- M	MOM y, KN- M	MOM z, KN- M
1	6188.2	535.89	-156.11	-0.4898	316.62	987.59
2	4105.6	403.14	-116.05	-0.4898	245.23	763.61
3	2022.9	409.27	-115.11	-0.4898	240.53	773.04
4	6521.0	506.11	-148.63	-0.4898	304.36	936.27
5	4561.9	358.42	-104.29	-0.4898	224.15	681.90
6	2479.3	362.25	-102.97	-0.4898	218.85	687.51
7	6825.0	504.49	-149.07	-0.4898	305.16	930.70
8	5018.2	357.77	-104.78	-0.4898	225.13	678.47
9	2935.6	361.80	-103.50	-0.4898	219.91	684.42
10	7129.1	535.49	-158.86	-0.4898	321.31	977.94
11	5474.6	408.70	-119.83	-0.4898	252.17	765.95
12	3391.9	414.67	-118.79	-0.4898	247.27	774.99
MINIMUM	2022.9	357.77	-158.86	-0.4898	218.85	678.47
Pile N.	3	8	10	1	6	8
MAXIMUM	7129.1	535.89	-102.97	-0.4898	321.31	987.59
Pile N.	10	1	6	1	10	1

PILE GROUP	STRESS, KN/ M**2
1	6631.8
2	4743.8
3	3588.1
4	6661.4
5	4747.8
6	3580.5
7	6818.2
8	4997.2
9	3830.8
10	7140.9
11	5531.7
12	4374.6
MINIMUM	3580.5
Pile N.	6
MAXIMUM	7140.9
Pile N.	10

* EFFECTS FOR LATERALLY LOADED PILE *

* MINIMUM VALUES AND LOCATIONS *

PILE	DISPL. y-DIR	DISPL. z-DIR	MOMENT z-DIR	MOMENT y-DIR	SHEAR y-DIR	SHEAR z-DIR	SOIL REACT y-DIR	SOIL REACT z-DIR	TOTAL STRESS	FLEX. RIG. z-DIR	FLEX. RIG. y-DIR
*****	*****	*****	*****	*****	*****	*****	*****	*****	*****	*****	*****
	M	M	KN- M	KN- M	KN	KN	KN/ M	KN/ M	KN/ M**2	KN- M**2	KN- M**2
1	-2.5310E-05	-5.2820E-04	-987.59	-159.35	-149.28	-156.15	-91.698	-35.999	3501.8	7.8279E+06	7.8279E+06
x(M)	9.1800	0.0000	0.0000	5.4000	7.8300	0.0000	10.260	4.0500	27.000	0.0000	0.0000
2	-1.9178E-05	-5.1990E-04	-763.61	-132.97	-121.06	-116.07	-58.344	-25.576	2323.3	7.8279E+06	7.8279E+06
x(M)	9.9900	0.0000	0.0000	5.6700	8.6400	0.0000	10.260	4.3200	27.000	0.0000	0.0000
3	-1.9386E-05	-5.1160E-04	-773.04	-131.79	-122.06	-115.12	-59.840	-25.437	1144.7	7.8279E+06	7.8279E+06
x(M)	9.9900	0.0000	0.0000	5.6700	8.6400	0.0000	10.260	4.3200	27.000	0.0000	0.0000
4	-2.4163E-05	-5.2820E-04	-936.27	-154.74	-142.89	-148.66	-85.966	-33.998	3690.1	7.8279E+06	7.8279E+06
x(M)	9.4500	0.0000	0.0000	5.4000	8.1000	0.0000	10.260	4.0500	27.000	0.0000	0.0000
5	-1.7297E-05	-5.1990E-04	-681.90	-125.05	-111.51	-104.31	-47.544	-22.591	2581.5	7.8279E+06	7.8279E+06
x(M)	10.260	0.0000	0.0000	5.9400	8.9100	0.0000	10.530	4.3200	27.000	0.0000	0.0000
6	-1.7400E-05	-5.1160E-04	-687.51	-123.55	-112.09	-102.98	-48.313	-22.354	1403.0	7.8279E+06	7.8279E+06
x(M)	10.260	0.0000	0.0000	5.9400	8.9100	0.0000	10.530	4.3200	27.000	0.0000	0.0000
7	-2.4181E-05	-5.2820E-04	-930.70	-155.06	-142.52	-149.11	-85.837	-34.128	3862.2	7.8279E+06	7.8279E+06
x(M)	9.4500	0.0000	0.0000	5.4000	8.1000	0.0000	10.260	4.0500	27.000	0.0000	0.0000
8	-1.7380E-05	-5.1990E-04	-678.47	-125.45	-111.42	-104.80	-47.896	-22.723	2839.7	7.8279E+06	7.8279E+06
x(M)	10.260	0.0000	0.0000	5.9400	8.9100	0.0000	10.530	4.3200	27.000	0.0000	0.0000
9	-1.7477E-05	-5.1160E-04	-684.42	-123.98	-112.09	-103.51	-48.694	-22.500	1661.2	7.8279E+06	7.8279E+06
x(M)	10.260	0.0000	0.0000	5.9400	8.9100	0.0000	10.530	4.3200	27.000	0.0000	0.0000
10	-2.5672E-05	-5.2820E-04	-977.94	-161.14	-149.41	-158.90	-92.010	-36.772	4034.3	7.8279E+06	7.8279E+06
x(M)	9.1800	0.0000	0.0000	5.4000	7.8300	0.0000	10.260	3.7800	27.000	0.0000	0.0000
11	-1.9757E-05	-5.1990E-04	-765.95	-135.78	-122.21	-119.85	-61.780	-26.572	3098.0	7.8279E+06	7.8279E+06
x(M)	9.9900	0.0000	0.0000	5.6700	8.6400	0.0000	10.260	4.3200	27.000	0.0000	0.0000

APPALTATORE: Consorzio Soci   		ITINERARIO NAPOLI – BARI RADDOPPIO TRATTA APICE – ORSARA I LOTTO FUNZIONALE APICE – HIRPINIA			
PROGETTAZIONE: Mandataria Mandanti   					
PROGETTO ESECUTIVO RELAZIONE DI CALCOLO FONDAZIONI SPALLA A					
COMMESSA	LOTTO	CODIFICA	DOCUMENTO	REV.	FOGLIO
IF1N	01 E ZZ	RG	MD0000 001	B	86 di 109

12	-1.9901E-05	-5.1160E-04	-774.99	-134.49	-123.16	-118.81	-63.177	-26.411	1919.4	7.8279E+06	7.8279E+06
x(M)	9.9900	0.0000	0.0000	5.6700	8.3700	0.0000	10.260	4.3200	27.000	0.0000	0.0000
Min. Pile N.	-2.5672E-05	-5.2820E-04	-987.59	-161.14	-149.41	-158.90	-92.010	-36.772	1144.7	7.8279E+06	7.8279E+06
	10	1	1	10	10	10	10	10	3	1	1

* MAXIMUM VALUES AND LOCATIONS *

PILE	DISPL. y-DIR	DISPL. z-DIR	MOMENT z-DIR	MOMENT y-DIR	SHEAR y-DIR	SHEAR z-DIR	SOIL REACT y-DIR	SOIL REACT z-DIR	TOTAL STRESS	FLEX. RIG. z-DIR	FLEX. RIG. y-DIR
	M	M	KN- M	KN- M	KN	KN	KN/ M	KN/ M	KN/ M**2	KN- M**2	KN- M**2
*****	*****	*****	*****	*****	*****	*****	*****	*****	*****	*****	*****
1	1.9697E-03	6.6491E-06	589.12	316.62	535.99	40.919	126.21	25.121	6631.8	7.8279E+06	7.8279E+06
x(M)	0.0000	9.4500	5.1300	0.0000	0.0000	8.1000	3.7800	10.260	0.0000	0.0000	0.0000
2	1.9697E-03	4.8857E-06	501.62	245.23	403.19	32.709	90.653	15.350	4743.8	7.8279E+06	7.8279E+06
x(M)	0.0000	10.260	5.6700	0.0000	0.0000	8.9100	4.3200	10.530	0.0000	0.0000	0.0000
3	1.9697E-03	4.8624E-06	505.11	240.53	409.30	32.413	92.140	15.412	3588.1	7.8279E+06	7.8279E+06
x(M)	0.0000	9.9900	5.6700	0.0000	0.0000	8.6400	4.0500	10.530	0.0000	0.0000	0.0000
4	1.9614E-03	6.3318E-06	570.20	304.36	506.22	39.459	118.26	23.542	6661.4	7.8279E+06	7.8279E+06
x(M)	0.0000	9.4500	5.4000	0.0000	0.0000	8.1000	10.260	0.0000	0.0000	0.0000	0.0000
5	1.9614E-03	4.4548E-06	469.86	224.15	358.47	30.325	79.540	12.484	4747.8	7.8279E+06	7.8279E+06
x(M)	0.0000	10.530	5.6700	0.0000	0.0000	9.1800	4.3200	10.800	0.0000	0.0000	0.0000
6	1.9614E-03	4.4076E-06	472.02	218.85	362.28	29.915	80.405	12.432	3580.5	7.8279E+06	7.8279E+06
x(M)	0.0000	10.530	5.6700	0.0000	0.0000	9.1800	4.3200	10.800	0.0000	0.0000	0.0000
7	1.9531E-03	6.3650E-06	568.78	305.16	504.60	39.555	118.05	23.623	6818.2	7.8279E+06	7.8279E+06
x(M)	0.0000	9.4500	5.4000	0.0000	0.0000	8.1000	3.7800	10.260	0.0000	0.0000	0.0000
8	1.9531E-03	4.4830E-06	469.37	225.13	357.83	30.437	79.529	12.584	4997.2	7.8279E+06	7.8279E+06
x(M)	0.0000	10.530	5.6700	0.0000	0.0000	9.1800	4.3200	10.800	0.0000	0.0000	0.0000
9	1.9531E-03	4.4334E-06	471.65	219.91	361.84	30.027	80.449	12.543	3830.8	7.8279E+06	7.8279E+06
x(M)	0.0000	10.530	5.6700	0.0000	0.0000	8.9100	4.3200	10.530	0.0000	0.0000	0.0000
10	1.9448E-03	6.7866E-06	588.26	321.31	535.61	41.481	126.81	25.611	7140.9	7.8279E+06	7.8279E+06
x(M)	0.0000	9.4500	5.1300	0.0000	0.0000	7.8300	3.7800	10.260	0.0000	0.0000	0.0000
11	1.9448E-03	5.1038E-06	504.80	252.17	408.77	33.575	92.652	16.312	5531.7	7.8279E+06	7.8279E+06
x(M)	0.0000	9.9900	5.4000	0.0000	0.0000	8.6400	4.0500	10.260	0.0000	0.0000	0.0000
12	1.9448E-03	5.0873E-06	508.37	247.27	414.72	33.225	94.113	16.464	4374.6	7.8279E+06	7.8279E+06
x(M)	0.0000	9.9900	5.4000	0.0000	0.0000	8.6400	4.0500	10.260	0.0000	0.0000	0.0000
Max. Pile N.	1.9697E-03	6.7866E-06	589.12	321.31	535.99	41.481	126.81	25.611	7140.9	7.8279E+06	7.8279E+06
	1	10	1	10	1	10	10	10	10	1	1

LOAD CASE : 12
CASE NAME : Load Case
LOAD TYPE : Special, Sp

REDUCTION FACTORS FOR CLOSELY-SPACED PILE GROUPS, COMBINED Y AND Z DIRECTIONS
ESTIMATED USING MOVEMENT IN THE DIRECTION OF PILE CAP DISPLACEMENTS

GROUP NO	P-FACTOR	Y-FACTOR
1	0.7576	1.0000
2	0.5450	1.0000
3	0.5845	1.0000
4	0.7048	1.0000
5	0.4813	1.0000
6	0.5172	1.0000
7	0.7166	1.0000
8	0.4956	1.0000
9	0.5331	1.0000
10	0.8661	1.0000
11	0.6858	1.0000
12	0.7195	1.0000

* TABLE L * COMPUTATION ON PILE CAP

* EQUIVALENT CONCENTRATED LOAD AT ORIGIN *

VERT. LOAD, KN	HOR. LOAD Y, KN	HOR. LOAD Z, KN
60235.3	2145.00	-2125.00
MOMENT X, KN- M	MOMENT Y, KN- M	MOMENT Z, KN- M
-438.000	-34225.5	-26581.5

* DISPLACEMENT OF GROUPED PILE FOUNDATION AT ORIGIN *

VERTICAL, M	HORIZONTAL Y, M	HORIZONTAL Z, M
2.60113E-03	6.45474E-04	-5.61873E-04
ANGLE ROT. X, RAD	ANGLE ROT. Y, RAD	ANGLE ROT. Z, RAD
-2.02594E-06	-6.80625E-05	-9.96832E-05

APPALTATORE: Consorzio  Soci  		ITINERARIO NAPOLI – BARI RADDOPPIO TRATTA APICE – ORSARA I LOTTO FUNZIONALE APICE – HIRPINIA					
PROGETTAZIONE: Mandataria  Mandanti  							
PROGETTO ESECUTIVO RELAZIONE DI CALCOLO FONDAZIONI SPALLA A							

THE GLOBAL STRUCTURAL COORDINATE SYSTEM

* PILE TOP DISPLACEMENTS *

PILE GROUP	DISP. X, M	DISP. Y, M	DISP. Z, M	ROT. X,RAD	ROT. Y,RAD	ROT. Z,RAD
1	2.5903E-03	6.5915E-04	-5.7099E-04	-2.0259E-06	-6.8062E-05	-9.9683E-05
2	2.1417E-03	6.5915E-04	-5.6187E-04	-2.0259E-06	-6.8062E-05	-9.9683E-05
3	1.6931E-03	6.5915E-04	-5.5276E-04	-2.0259E-06	-6.8062E-05	-9.9683E-05
4	2.8966E-03	6.5003E-04	-5.7099E-04	-2.0259E-06	-6.8062E-05	-9.9683E-05
5	2.4480E-03	6.5003E-04	-5.6187E-04	-2.0259E-06	-6.8062E-05	-9.9683E-05
6	1.9994E-03	6.5003E-04	-5.5276E-04	-2.0259E-06	-6.8062E-05	-9.9683E-05
7	3.2028E-03	6.4092E-04	-5.7099E-04	-2.0259E-06	-6.8062E-05	-9.9683E-05
8	2.7543E-03	6.4092E-04	-5.6187E-04	-2.0259E-06	-6.8062E-05	-9.9683E-05
9	2.3057E-03	6.4092E-04	-5.5276E-04	-2.0259E-06	-6.8062E-05	-9.9683E-05
10	3.5091E-03	6.3180E-04	-5.7099E-04	-2.0259E-06	-6.8062E-05	-9.9683E-05
11	3.0605E-03	6.3180E-04	-5.6187E-04	-2.0259E-06	-6.8062E-05	-9.9683E-05
12	2.6120E-03	6.3180E-04	-5.5276E-04	-2.0259E-06	-6.8062E-05	-9.9683E-05
MINIMUM	1.6931E-03	6.3180E-04	-5.7099E-04	-2.0259E-06	-6.8062E-05	-9.9683E-05
Pile N.	3	10	1	1	1	1
MAXIMUM	3.5091E-03	6.5915E-04	-5.5276E-04	-2.0259E-06	-6.8062E-05	-9.9683E-05
Pile N.	10	1	3	1	1	1

* PILE TOP REACTIONS *

PILE GROUP	FOR. X, KN	FOR. Y, KN	FOR. Z, KN	MOM X, KN- M	MOM Y, KN- M	MOM Z, KN- M
1	5012.4	208.42	-202.59	-0.5379	371.25	330.24
2	4160.9	166.91	-160.36	-0.5379	302.22	267.46
3	3309.3	175.68	-164.39	-0.5379	304.62	280.85
4	5593.9	194.56	-193.83	-0.5379	358.20	305.69
5	4742.3	150.06	-148.23	-0.5379	282.78	237.24
6	3890.7	158.24	-152.13	-0.5379	285.30	249.99
7	6175.3	192.89	-196.42	-0.5379	362.20	299.07
8	5323.7	149.93	-151.46	-0.5379	288.10	233.42
9	4472.2	158.29	-155.60	-0.5379	290.91	246.35
10	6595.7	215.30	-222.60	-0.5379	400.87	327.04
11	5905.2	183.95	-187.66	-0.5379	344.80	281.56
12	5053.6	190.78	-189.74	-0.5379	343.65	291.46
MINIMUM	3309.3	149.93	-222.60	-0.5379	282.78	233.42
Pile N.	3	8	10	1	5	8
MAXIMUM	6595.7	215.30	-148.23	-0.5379	400.87	330.24
Pile N.	10	10	5	1	10	1

THE PILE COORDINATE SYSTEM (LOCAL AXES)

* PILE TOP DISPLACEMENTS *

PILE GROUP	DISP. x, M	DISP. y, M	DISP. z, M	ROT. x,RAD	ROT. y,RAD	ROT. z,RAD
1	2.5903E-03	6.5915E-04	-5.7099E-04	-2.0259E-06	-6.8062E-05	-9.9683E-05
2	2.1417E-03	6.5915E-04	-5.6187E-04	-2.0259E-06	-6.8062E-05	-9.9683E-05
3	1.6931E-03	6.5915E-04	-5.5276E-04	-2.0259E-06	-6.8062E-05	-9.9683E-05
4	2.8966E-03	6.5003E-04	-5.7099E-04	-2.0259E-06	-6.8062E-05	-9.9683E-05
5	2.4480E-03	6.5003E-04	-5.6187E-04	-2.0259E-06	-6.8062E-05	-9.9683E-05
6	1.9994E-03	6.5003E-04	-5.5276E-04	-2.0259E-06	-6.8062E-05	-9.9683E-05
7	3.2028E-03	6.4092E-04	-5.7099E-04	-2.0259E-06	-6.8062E-05	-9.9683E-05
8	2.7543E-03	6.4092E-04	-5.6187E-04	-2.0259E-06	-6.8062E-05	-9.9683E-05
9	2.3057E-03	6.4092E-04	-5.5276E-04	-2.0259E-06	-6.8062E-05	-9.9683E-05
10	3.5091E-03	6.3180E-04	-5.7099E-04	-2.0259E-06	-6.8062E-05	-9.9683E-05
11	3.0605E-03	6.3180E-04	-5.6187E-04	-2.0259E-06	-6.8062E-05	-9.9683E-05
12	2.6120E-03	6.3180E-04	-5.5276E-04	-2.0259E-06	-6.8062E-05	-9.9683E-05
MINIMUM	1.6931E-03	6.3180E-04	-5.7099E-04	-2.0259E-06	-6.8062E-05	-9.9683E-05
Pile N.	3	10	1	1	1	1
MAXIMUM	3.5091E-03	6.5915E-04	-5.5276E-04	-2.0259E-06	-6.8062E-05	-9.9683E-05
Pile N.	10	1	3	1	1	1

* PILE TOP REACTIONS *

PILE GROUP	AXIAL, KN	LAT. y, KN	LAT. z, KN	MOM x, KN- M	MOM y, KN- M	MOM z, KN- M
1	5012.4	208.42	-202.59	-0.5379	371.25	330.24
2	4160.9	166.91	-160.36	-0.5379	302.22	267.46
3	3309.3	175.68	-164.39	-0.5379	304.62	280.85
4	5593.9	194.56	-193.83	-0.5379	358.20	305.69
5	4742.3	150.06	-148.23	-0.5379	282.78	237.24
6	3890.7	158.24	-152.13	-0.5379	285.30	249.99
7	6175.3	192.89	-196.42	-0.5379	362.20	299.07
8	5323.7	149.93	-151.46	-0.5379	288.10	233.42
9	4472.2	158.29	-155.60	-0.5379	290.91	246.35
10	6595.7	215.30	-222.60	-0.5379	400.87	327.04

APPALTATORE:

Consorzio

Soci



ITINERARIO NAPOLI – BARI

PROGETTAZIONE:

Mandatario

Mandanti



RADDOPPIO TRATTA APICE – ORSARA
I LOTTO FUNZIONALE APICE – HIRPINIA

PROGETTO ESECUTIVO

RELAZIONE DI CALCOLO FONDAZIONI SPALLA A

COMMESSA IF1N	LOTTO 01 E ZZ	CODIFICA RG	DOCUMENTO MD0000 001	REV. B	FOGLIO 88 di 109
------------------	------------------	----------------	-------------------------	-----------	---------------------

11	5905.2	183.95	-187.66	-0.5379	344.80	281.56
12	5053.6	190.78	-189.74	-0.5379	343.65	291.46
MINIMUM Pile N.	3309.3 3	149.93 8	-222.60 10	-0.5379 1	282.78 5	233.42 8
MAXIMUM Pile N.	6595.7 10	215.30 10	-148.23 5	-0.5379 1	400.87 10	330.24 1

PILE GROUP STRESS, KN/ M**2

*****	*****
1	4336.0
2	3572.6
3	3123.2
4	4586.7
5	3797.6
6	3346.6
7	4912.1
8	4131.7
9	3681.2
10	5293.8
11	4685.2
12	4219.7

MINIMUM Pile N.	3123.2 3
MAXIMUM Pile N.	5293.8 10

* EFFECTS FOR Laterally LOADED PILE *

* MINIMUM VALUES AND LOCATIONS *

PILE	DISPL. y-DIR M	DISPL. z-DIR M	MOMENT z-DIR KN- M	MOMENT y-DIR KN- M	SHEAR y-DIR KN	SHEAR z-DIR KN	SOIL REACT y-DIR KN/ M	SOIL REACT z-DIR KN/ M	TOTAL STRESS KN/ M**2	FLEX. RIG. z-DIR KN- M**2	FLEX. RIG. y-DIR KN- M**2
*****	*****	*****	*****	*****	*****	*****	*****	*****	*****	*****	*****
1	-1.2962E-05	-5.7099E-04	-330.24	-199.42	-56.299	-202.62	-30.899	-52.684	2836.5	7.8279E+06	7.8279E+06
x(M)	8.6400	0.0000	0.0000	4.8600	7.0200	0.0000	10.260	4.0500	27.000	0.0000	0.0000
2	-1.1549E-05	-5.6187E-04	-267.46	-174.78	-47.425	-160.38	-25.726	-41.937	2354.6	7.8279E+06	7.8279E+06
x(M)	9.1800	0.0000	0.0000	5.1300	7.5600	0.0000	10.260	4.3200	27.000	0.0000	0.0000
3	-1.1901E-05	-5.5276E-04	-280.85	-176.14	-49.157	-164.41	-26.940	-43.058	1872.7	7.8279E+06	7.8279E+06
x(M)	8.9100	0.0000	0.0000	5.1300	7.2900	0.0000	10.260	4.3200	27.000	0.0000	0.0000
4	-1.2565E-05	-5.7099E-04	-305.69	-194.60	-53.429	-193.86	-29.442	-50.434	3165.5	7.8279E+06	7.8279E+06
x(M)	8.6400	0.0000	0.0000	4.8600	7.0200	0.0000	10.260	4.0500	27.000	0.0000	0.0000
5	-1.0951E-05	-5.6187E-04	-237.24	-167.45	-43.968	-148.25	-23.182	-38.821	2683.6	7.8279E+06	7.8279E+06
x(M)	9.1800	0.0000	0.0000	5.1300	7.5600	0.0000	10.260	4.3200	27.000	0.0000	0.0000
6	-1.1282E-05	-5.5276E-04	-249.99	-169.08	-45.609	-152.15	-24.464	-39.963	2201.7	7.8279E+06	7.8279E+06
x(M)	9.1800	0.0000	0.0000	5.1300	7.5600	0.0000	10.260	4.3200	27.000	0.0000	0.0000
7	-1.2543E-05	-5.7099E-04	-299.07	-196.00	-53.235	-196.46	-29.205	-51.202	3494.5	7.8279E+06	7.8279E+06
x(M)	8.6400	0.0000	0.0000	4.8600	7.0200	0.0000	10.260	4.0500	27.000	0.0000	0.0000
8	-1.1025E-05	-5.6187E-04	-233.42	-169.39	-44.047	-151.49	-23.397	-39.755	3012.6	7.8279E+06	7.8279E+06
x(M)	9.1800	0.0000	0.0000	5.1300	7.5600	0.0000	10.260	4.3200	27.000	0.0000	0.0000
9	-1.1316E-05	-5.5276E-04	-246.35	-171.06	-45.674	-155.62	-24.656	-40.947	2530.7	7.8279E+06	7.8279E+06
x(M)	9.1800	0.0000	0.0000	5.1300	7.5600	0.0000	10.260	4.3200	27.000	0.0000	0.0000
10	-1.3079E-05	-5.7099E-04	-327.04	-209.49	-58.078	-222.64	-30.842	-58.481	3732.4	7.8279E+06	7.8279E+06
x(M)	8.3700	0.0000	0.0000	4.8600	6.7500	0.0000	10.260	3.7800	27.000	0.0000	0.0000
11	-1.2283E-05	-5.6187E-04	-281.56	-190.23	-51.325	-187.70	-28.151	-49.080	3341.7	7.8279E+06	7.8279E+06
x(M)	8.6400	0.0000	0.0000	4.8600	7.0200	0.0000	10.260	4.3200	27.000	0.0000	0.0000
12	-1.2496E-05	-5.5276E-04	-291.46	-190.50	-52.712	-189.77	-28.783	-49.752	2859.8	7.8279E+06	7.8279E+06
x(M)	8.6400	0.0000	0.0000	4.8600	7.0200	0.0000	10.260	4.0500	27.000	0.0000	0.0000
Min. Pile N.	-1.3079E-05 10	-5.7099E-04 1	-330.24 1	-209.49 10	-58.078 10	-222.64 10	-30.899 1	-58.481 10	1872.7 3	7.8279E+06 1	7.8279E+06 1

* MAXIMUM VALUES AND LOCATIONS *

PILE	DISPL. y-DIR M	DISPL. z-DIR M	MOMENT z-DIR KN- M	MOMENT y-DIR KN- M	SHEAR y-DIR KN	SHEAR z-DIR KN	SOIL REACT y-DIR KN/ M	SOIL REACT z-DIR KN/ M	TOTAL STRESS KN/ M**2	FLEX. RIG. z-DIR KN- M**2	FLEX. RIG. y-DIR KN- M**2
*****	*****	*****	*****	*****	*****	*****	*****	*****	*****	*****	*****
1	6.5915E-04	1.0755E-05	229.51	371.25	208.45	49.303	55.450	27.784	4336.0	7.8279E+06	7.8279E+06
x(M)	0.0000	8.9100	4.5900	0.0000	0.0000	7.2900	3.7800	10.260	0.0000	0.0000	0.0000
2	6.5915E-04	9.3134E-06	205.43	302.22	166.93	40.815	44.418	22.191	3572.6	7.8279E+06	7.8279E+06
x(M)	0.0000	9.1800	4.8600	0.0000	0.0000	7.5600	4.3200	10.260	0.0000	0.0000	0.0000
3	6.5915E-04	9.4958E-06	210.53	304.62	175.69	41.644	46.673	22.966	3123.2	7.8279E+06	7.8279E+06
x(M)	0.0000	9.1800	4.8600	0.0000	0.0000	7.5600	4.3200	10.260	0.0000	0.0000	0.0000
4	6.5003E-04	1.0546E-05	221.06	358.20	194.59	47.526	51.807	26.781	4586.7	7.8279E+06	7.8279E+06
x(M)	0.0000	8.9100	4.5900	0.0000	0.0000	7.2900	3.7800	10.260	0.0000	0.0000	0.0000
5	6.5003E-04	8.8191E-06	194.45	282.78	150.08	38.429	40.213	20.043	3797.6	7.8279E+06	7.8279E+06
x(M)	0.0000	9.4500	4.8600	0.0000	0.0000	7.8300	4.3200	10.260	0.0000	0.0000	0.0000
6	6.5003E-04	8.9806E-06	199.49	285.30	158.26	39.142	42.370	20.956	3346.6	7.8279E+06	7.8279E+06
x(M)	0.0000	9.1800	4.8600	0.0000	0.0000	7.8300	4.3200	10.260	0.0000	0.0000	0.0000
7	6.4092E-04	1.0635E-05	219.68	362.20	192.92	48.006	51.566	27.040	4912.1	7.8279E+06	7.8279E+06
x(M)	0.0000	8.9100	4.5900	0.0000	0.0000	7.2900	3.7800	10.260	0.0000	0.0000	0.0000
8	6.4092E-04	8.9591E-06	194.04	288.10	149.95	39.042	40.287	20.588	4131.7	7.8279E+06	7.8279E+06
x(M)	0.0000	9.4500	4.8600	0.0000	0.0000	7.8300	4.3200	10.260	0.0000	0.0000	0.0000
9	6.4092E-04	9.1627E-06	199.09	290.91	158.31	39.752	42.470	21.498	3681.2	7.8279E+06	7.8279E+06
x(M)	0.0000	9.1800	4.8600	0.0000	0.0000	7.5600	4.3200	10.260	0.0000	0.0000	0.0000

APPALTATORE: Consorzio  Soci  		ITINERARIO NAPOLI – BARI RADDOPPIO TRATTA APICE – ORSARA I LOTTO FUNZIONALE APICE – HIRPINIA					
PROGETTAZIONE: Mandataria  Mandanti  							
PROGETTO ESECUTIVO RELAZIONE DI CALCOLO FONDAZIONI SPALLA A		COMMESSA IF1N	LOTTO 01 E ZZ	CODIFICA RG	DOCUMENTO MD0000 001	REV. B	FOGLIO 90 di 109

1	5330.5	296.15	-207.25	-0.3434	388.47	490.04
2	4152.6	233.33	-162.85	-0.3434	316.63	393.52
3	2974.6	241.53	-165.94	-0.3434	319.03	406.14
4	5929.0	279.83	-198.14	-0.3434	374.78	463.26
5	4751.1	210.99	-149.41	-0.3434	294.71	355.42
6	3573.1	218.38	-152.18	-0.3434	296.84	367.07
7	6443.0	279.43	-199.69	-0.3434	377.26	460.17
8	5349.6	211.88	-151.46	-0.3434	298.22	354.78
9	4171.6	219.59	-154.45	-0.3434	300.67	366.87
10	6841.8	305.90	-219.66	-0.3434	407.29	496.55
11	5948.1	252.98	-180.89	-0.3434	345.64	417.39
12	4770.2	260.01	-183.09	-0.3434	346.37	427.80
MINIMUM	2974.6	210.99	-219.66	-0.3434	294.71	354.78
Pile N.	3	5	10	1	5	8
MAXIMUM	6841.8	305.90	-149.41	-0.3434	407.29	496.55
Pile N.	10	10	5	1	10	10

THE PILE COORDINATE SYSTEM (LOCAL AXES)

* PILE TOP DISPLACEMENTS *

PILE GROUP	DISP. x, M	DISP. y, M	DISP. z, M	ROT. x,RAD	ROT. y,RAD	ROT. z,RAD
*****	*****	*****	*****	*****	*****	*****
1	2.7578E-03	9.5656E-04	-6.0449E-04	-1.2933E-06	-7.0062E-05	-1.3789E-04
2	2.1373E-03	9.5656E-04	-5.9868E-04	-1.2933E-06	-7.0062E-05	-1.3789E-04
3	1.5168E-03	9.5656E-04	-5.9285E-04	-1.2933E-06	-7.0062E-05	-1.3789E-04
4	3.0731E-03	9.5074E-04	-6.0449E-04	-1.2933E-06	-7.0062E-05	-1.3789E-04
5	2.4526E-03	9.5074E-04	-5.9868E-04	-1.2933E-06	-7.0062E-05	-1.3789E-04
6	1.8321E-03	9.5074E-04	-5.9285E-04	-1.2933E-06	-7.0062E-05	-1.3789E-04
7	3.3884E-03	9.4492E-04	-6.0449E-04	-1.2933E-06	-7.0062E-05	-1.3789E-04
8	2.7679E-03	9.4492E-04	-5.9868E-04	-1.2933E-06	-7.0062E-05	-1.3789E-04
9	2.1474E-03	9.4492E-04	-5.9285E-04	-1.2933E-06	-7.0062E-05	-1.3789E-04
10	3.7037E-03	9.3910E-04	-6.0449E-04	-1.2933E-06	-7.0062E-05	-1.3789E-04
11	3.0832E-03	9.3910E-04	-5.9868E-04	-1.2933E-06	-7.0062E-05	-1.3789E-04
12	2.4627E-03	9.3910E-04	-5.9285E-04	-1.2933E-06	-7.0062E-05	-1.3789E-04
MINIMUM	1.5168E-03	9.3910E-04	-6.0449E-04	-1.2933E-06	-7.0062E-05	-1.3789E-04
Pile N.	3	10	1	1	1	1
MAXIMUM	3.7037E-03	9.5656E-04	-5.9285E-04	-1.2933E-06	-7.0062E-05	-1.3789E-04
Pile N.	10	1	3	1	1	1

* PILE TOP REACTIONS *

PILE GROUP	AXIAL, KN	LAT. y, KN	LAT. z, KN	MOM x, KN- M	MOM y, KN- M	MOM z, KN- M
*****	*****	*****	*****	*****	*****	*****
1	5330.5	296.15	-207.25	-0.3434	388.47	490.04
2	4152.6	233.33	-162.85	-0.3434	316.63	393.52
3	2974.6	241.53	-165.94	-0.3434	319.03	406.14
4	5929.0	279.83	-198.14	-0.3434	374.78	463.26
5	4751.1	210.99	-149.41	-0.3434	294.71	355.42
6	3573.1	218.38	-152.18	-0.3434	296.84	367.07
7	6443.0	279.43	-199.69	-0.3434	377.26	460.17
8	5349.6	211.88	-151.46	-0.3434	298.22	354.78
9	4171.6	219.59	-154.45	-0.3434	300.67	366.87
10	6841.8	305.90	-219.66	-0.3434	407.29	496.55
11	5948.1	252.98	-180.89	-0.3434	345.64	417.39
12	4770.2	260.01	-183.09	-0.3434	346.37	427.80
MINIMUM	2974.6	210.99	-219.66	-0.3434	294.71	354.78
Pile N.	3	5	10	1	5	8
MAXIMUM	6841.8	305.90	-149.41	-0.3434	407.29	496.55
Pile N.	10	10	5	1	10	10

PILE GROUP STRESS, KN/ M**2

*****	*****
1	4903.8
2	3874.3
3	3242.0
4	5153.5
5	4082.0
6	3446.7
7	5441.9
8	4426.0
9	3792.3
10	5809.9
11	5001.5
12	4360.6
MINIMUM	3242.0
Pile N.	3
MAXIMUM	5809.9
Pile N.	10

* EFFECTS FOR LATERALLY LOADED PILE *

APPALTATORE: Consorzio HirpiniaAV Soci salini impreglio ASTALDI		ITINERARIO NAPOLI – BARI RADDOPPIO TRATTA APICE – ORSARA I LOTTO FUNZIONALE APICE – HIRPINIA			
PROGETTAZIONE: Mandatario ROKSOIL Mandanti NETENGINEERING Alpina					
PROGETTO ESECUTIVO RELAZIONE DI CALCOLO FONDAZIONI SPALLA A					
COMMESSA	LOTTO	CODIFICA	DOCUMENTO	REV.	FOGLIO
IF1N	01 E ZZ	RG	MD0000 001	B	91 di 109

* MINIMUM VALUES AND LOCATIONS *

PILE	DISPL. y-DIR M	DISPL. z-DIR M	MOMENT z-DIR KN- M	MOMENT y-DIR KN- M	SHEAR y-DIR KN	SHEAR z-DIR KN	SOIL REACT y-DIR KN/ M	SOIL REACT z-DIR KN/ M	TOTAL STRESS KN/ M**2	FLEX. RIG. z-DIR KN- M**2	FLEX. RIG. y-DIR KN- M**2
*****	*****	*****	*****	*****	*****	*****	*****	*****	*****	*****	*****
1	-1.7751E-05	-6.0449E-04	-490.04	-208.11	-81.612	-207.29	-45.874	-52.838	3016.5	7.8279E+06	7.8279E+06
x (M)	8.6400	0.0000	0.0000	4.8600	7.2900	0.0000	10.260	4.0500	27.000	0.0000	0.0000
2	-1.5682E-05	-5.9867E-04	-393.52	-182.70	-68.187	-162.88	-37.234	-41.467	2349.9	7.8279E+06	7.8279E+06
x (M)	9.1800	0.0000	0.0000	5.1300	7.5600	0.0000	10.260	4.3200	27.000	0.0000	0.0000
3	-1.5962E-05	-5.9286E-04	-406.14	-184.06	-69.860	-165.96	-38.520	-42.328	1683.3	7.8279E+06	7.8279E+06
x (M)	9.1800	0.0000	0.0000	5.1300	7.5600	0.0000	10.260	4.3200	27.000	0.0000	0.0000
4	-1.7280E-05	-6.0449E-04	-463.26	-203.39	-78.342	-198.18	-44.063	-50.538	3355.1	7.8279E+06	7.8279E+06
x (M)	8.9100	0.0000	0.0000	5.1300	7.2900	0.0000	10.260	4.3200	27.000	0.0000	0.0000
5	-1.4781E-05	-5.9867E-04	-355.42	-174.52	-63.454	-149.43	-37.309	-37.920	2688.6	7.8279E+06	7.8279E+06
x (M)	9.4500	0.0000	0.0000	5.4000	7.8300	0.0000	10.260	4.5900	27.000	0.0000	0.0000
6	-1.5030E-05	-5.9286E-04	-367.07	-175.54	-64.891	-152.20	-34.623	-38.726	2022.0	7.8279E+06	7.8279E+06
x (M)	9.1800	0.0000	0.0000	5.4000	7.8300	0.0000	10.260	4.3200	27.000	0.0000	0.0000
7	-1.7264E-05	-6.0449E-04	-460.17	-204.22	-78.296	-199.73	-43.989	-50.964	3646.0	7.8279E+06	7.8279E+06
x (M)	8.9100	0.0000	0.0000	5.1300	7.2900	0.0000	10.260	4.3200	27.000	0.0000	0.0000
8	-1.4848E-05	-5.9867E-04	-354.78	-175.76	-63.681	-151.48	-33.673	-38.508	3027.3	7.8279E+06	7.8279E+06
x (M)	9.4500	0.0000	0.0000	5.4000	7.8300	0.0000	10.260	4.3200	27.000	0.0000	0.0000
9	-1.5171E-05	-5.9286E-04	-366.87	-177.00	-65.151	-154.47	-35.016	-39.370	2360.7	7.8279E+06	7.8279E+06
x (M)	9.1800	0.0000	0.0000	5.1300	7.8300	0.0000	10.260	4.3200	27.000	0.0000	0.0000
10	-1.8019E-05	-6.0449E-04	-496.55	-215.01	-84.067	-219.71	-46.465	-56.261	3871.7	7.8279E+06	7.8279E+06
x (M)	8.6400	0.0000	0.0000	4.8600	7.0200	0.0000	10.260	3.7800	27.000	0.0000	0.0000
11	-1.6527E-05	-5.9867E-04	-417.39	-193.45	-72.547	-180.92	-46.589	-46.280	3365.9	7.8279E+06	7.8279E+06
x (M)	8.9100	0.0000	0.0000	5.1300	7.2900	0.0000	10.260	4.3200	27.000	0.0000	0.0000
12	-1.6747E-05	-5.9286E-04	-427.80	-193.99	-73.993	-183.11	-41.467	-46.868	2699.4	7.8279E+06	7.8279E+06
x (M)	8.9100	0.0000	0.0000	5.1300	7.2900	0.0000	10.260	4.3200	27.000	0.0000	0.0000
Min.	-1.8019E-05	-6.0449E-04	-496.55	-215.01	-84.067	-219.71	-46.465	-56.261	1683.3	7.8279E+06	7.8279E+06
Pile N.	10	1	10	10	10	10	10	10	3	1	1

* MAXIMUM VALUES AND LOCATIONS *

PILE	DISPL. y-DIR M	DISPL. z-DIR M	MOMENT z-DIR KN- M	MOMENT y-DIR KN- M	SHEAR y-DIR KN	SHEAR z-DIR KN	SOIL REACT y-DIR KN/ M	SOIL REACT z-DIR KN/ M	TOTAL STRESS KN/ M**2	FLEX. RIG. z-DIR KN- M**2	FLEX. RIG. y-DIR KN- M**2
*****	*****	*****	*****	*****	*****	*****	*****	*****	*****	*****	*****
1	9.5656E-04	1.0891E-05	327.82	388.47	296.19	52.401	76.951	30.016	4903.8	7.8279E+06	7.8279E+06
x (M)	0.0000	8.9100	4.8600	0.0000	0.0000	7.2900	3.7800	10.260	0.0000	0.0000	0.0000
2	9.5656E-04	9.3245E-06	290.98	316.63	233.36	43.294	60.569	23.554	3874.3	7.8279E+06	7.8279E+06
x (M)	0.0000	9.4500	5.1300	0.0000	0.0000	7.8300	4.3200	10.260	0.0000	0.0000	0.0000
3	9.5656E-04	9.4657E-06	295.59	319.03	241.55	43.829	62.675	24.206	3242.0	7.8279E+06	7.8279E+06
x (M)	0.0000	9.1800	5.1300	0.0000	0.0000	7.8300	4.3200	10.260	0.0000	0.0000	0.0000
4	9.5074E-04	1.0651E-05	318.45	374.78	279.88	50.458	72.608	28.921	5153.5	7.8279E+06	7.8279E+06
x (M)	0.0000	8.9100	4.8600	0.0000	0.0000	7.2900	4.0500	10.260	0.0000	0.0000	0.0000
5	9.5074E-04	8.7789E-06	276.89	294.71	211.01	40.515	54.845	20.948	4082.0	7.8279E+06	7.8279E+06
x (M)	0.0000	9.4500	5.1300	0.0000	0.0000	8.1000	4.3200	10.260	0.0000	0.0000	0.0000
6	9.5074E-04	8.9310E-06	281.37	296.84	218.40	41.009	56.783	21.660	3446.7	7.8279E+06	7.8279E+06
x (M)	0.0000	9.4500	5.1300	0.0000	0.0000	7.8300	4.3200	10.260	0.0000	0.0000	0.0000
7	9.4492E-04	1.0716E-05	317.82	377.26	279.48	50.790	72.611	29.098	5441.9	7.8279E+06	7.8279E+06
x (M)	0.0000	8.9100	4.8600	0.0000	0.0000	7.2900	4.0500	10.260	0.0000	0.0000	0.0000
8	9.4492E-04	8.8956E-06	277.19	298.22	211.92	40.906	55.186	21.351	4426.0	7.8279E+06	7.8279E+06
x (M)	0.0000	9.4500	5.1300	0.0000	0.0000	8.1000	4.3200	10.260	0.0000	0.0000	0.0000
9	9.4492E-04	9.0407E-06	281.80	300.67	219.62	41.493	57.198	22.088	3792.3	7.8279E+06	7.8279E+06
x (M)	0.0000	9.4500	5.1300	0.0000	0.0000	7.8300	4.3200	10.260	0.0000	0.0000	0.0000
10	9.3910E-04	1.1269E-05	331.32	407.29	305.96	54.844	80.164	31.220	5809.9	7.8279E+06	7.8279E+06
x (M)	0.0000	8.6400	4.5900	0.0000	0.0000	7.2900	3.7800	10.260	0.0000	0.0000	0.0000
11	9.3910E-04	1.0074E-05	302.11	345.64	253.02	46.964	65.791	26.512	5001.5	7.8279E+06	7.8279E+06
x (M)	0.0000	9.1800	4.8600	0.0000	0.0000	7.5600	4.3200	10.260	0.0000	0.0000	0.0000
12	9.3910E-04	1.0113E-05	306.09	346.37	260.04	47.348	67.568	26.865	4360.6	7.8279E+06	7.8279E+06
x (M)	0.0000	8.9100	4.8600	0.0000	0.0000	7.5600	4.0500	10.260	0.0000	0.0000	0.0000
Max.	9.5656E-04	1.1269E-05	331.32	407.29	305.96	54.844	80.164	31.220	5809.9	7.8279E+06	7.8279E+06
Pile N.	1	10	10	10	10	10	10	10	10	1	1

LOAD CASE : 14
CASE NAME : Load Case
LOAD TYPE : Special, Sp

REDUCTION FACTORS FOR CLOSELY-SPACED PILE GROUPS, COMBINED Y AND Z DIRECTIONS
ESTIMATED USING MOVEMENT IN THE DIRECTION OF PILE CAP DISPLACEMENTS

GROUP NO	P-FACTOR	Y-FACTOR
1	0.6349	1.0000
2	0.5098	1.0000
3	0.5845	1.0000
4	0.5911	1.0000
5	0.4676	1.0000
6	0.5374	1.0000
7	0.6184	1.0000
8	0.4960	1.0000
9	0.5673	1.0000

APPALTATORE: Consorzio  Soci  	ITINERARIO NAPOLI – BARI RADDOPPIO TRATTA APICE – ORSARA I LOTTO FUNZIONALE APICE – HIRPINIA
PROGETTAZIONE: Mandataria  Mandanti  	
PROGETTO ESECUTIVO RELAZIONE DI CALCOLO FONDAZIONI SPALLA A	COMMESSA IF1N LOTTO 01 E ZZ CODIFICA RG DOCUMENTO MD0000 001 REV. B FOGLIO 92 di 109

10	0.8661	1.0000
11	0.7755	1.0000
12	0.8298	1.0000

* TABLE L * COMPUTATION ON PILE CAP

* EQUIVALENT CONCENTRATED LOAD AT ORIGIN *

VERT. LOAD, KN 38347.3	HOR. LOAD Y, KN 623.000	HOR. LOAD Z, KN -1806.00
MOMENT X, KN- M -502.000	MOMENT Y, KN- M -28049.0	MOMENT Z, KN- M -8915.50

* DISPLACEMENT OF GROUPED PILE FOUNDATION AT ORIGIN *

VERTICAL, M 1.63324E-03	HORIZONTAL Y, M 1.76883E-04	HORIZONTAL Z, M -4.20192E-04
ANGLE ROT. X, RAD -2.87471E-06	ANGLE ROT. Y, RAD -5.40721E-05	ANGLE ROT. Z, RAD -3.16299E-05

THE GLOBAL STRUCTURAL COORDINATE SYSTEM

* PILE TOP DISPLACEMENTS *

PILE GROUP	DISP. X, M	DISP. Y, M	DISP. Z, M	ROT. X, RAD	ROT. Y, RAD	ROT. Z, RAD
*****	*****	*****	*****	*****	*****	*****
1	1.4106E-03	1.9629E-04	-4.3313E-04	-2.8747E-06	-5.4072E-05	-3.1630E-05
2	1.2683E-03	1.9629E-04	-4.2019E-04	-2.8747E-06	-5.4072E-05	-3.1630E-05
3	1.1259E-03	1.9629E-04	-4.0726E-04	-2.8747E-06	-5.4072E-05	-3.1630E-05
4	1.6539E-03	1.8335E-04	-4.3313E-04	-2.8747E-06	-5.4072E-05	-3.1630E-05
5	1.5116E-03	1.8335E-04	-4.2019E-04	-2.8747E-06	-5.4072E-05	-3.1630E-05
6	1.3693E-03	1.8335E-04	-4.0726E-04	-2.8747E-06	-5.4072E-05	-3.1630E-05
7	1.8972E-03	1.7041E-04	-4.3313E-04	-2.8747E-06	-5.4072E-05	-3.1630E-05
8	1.7549E-03	1.7041E-04	-4.2019E-04	-2.8747E-06	-5.4072E-05	-3.1630E-05
9	1.6126E-03	1.7041E-04	-4.0726E-04	-2.8747E-06	-5.4072E-05	-3.1630E-05
10	2.1406E-03	1.5748E-04	-4.3313E-04	-2.8747E-06	-5.4072E-05	-3.1630E-05
11	1.9982E-03	1.5748E-04	-4.2019E-04	-2.8747E-06	-5.4072E-05	-3.1630E-05
12	1.8559E-03	1.5748E-04	-4.0726E-04	-2.8747E-06	-5.4072E-05	-3.1630E-05
MINIMUM	1.1259E-03	1.5748E-04	-4.3313E-04	-2.8747E-06	-5.4072E-05	-3.1630E-05
Pile N.	3	10	1	1	1	1
MAXIMUM	2.1406E-03	1.9629E-04	-4.0726E-04	-2.8747E-06	-5.4072E-05	-3.1630E-05
Pile N.	10	1	3	1	1	1





* PILE TOP REACTIONS *

PILE GROUP	FOR. X, KN	FOR. Y, KN	FOR. Z, KN	MOM X, KN- M	MOM Y, KN- M	MOM Z, KN- M
*****	*****	*****	*****	*****	*****	*****
1	2772.9	62.811	-157.86	-0.7633	278.47	92.956
2	2502.7	54.196	-131.43	-0.7633	232.65	80.145
3	2232.5	60.226	-138.77	-0.7633	237.98	89.052
4	3234.9	53.462	-150.94	-0.7633	268.14	73.269
5	2964.6	45.455	-124.33	-0.7633	221.60	61.287
6	2694.4	50.761	-131.51	-0.7633	227.04	69.181
7	3696.8	48.771	-155.98	-0.7633	275.67	60.346
8	3426.6	41.747	-129.76	-0.7633	230.05	50.045
9	3156.4	46.591	-136.86	-0.7633	235.11	57.105
10	4158.7	54.501	-195.56	-0.7633	332.58	61.548
11	3888.5	50.660	-175.65	-0.7633	297.90	56.364
12	3618.3	53.818	-177.34	-0.7633	293.60	60.594
MINIMUM	2232.5	41.747	-195.56	-0.7633	221.60	50.045
Pile N.	3	8	10	1	5	8
MAXIMUM	4158.7	62.811	-124.33	-0.7633	332.58	92.956
Pile N.	10	1	5	1	10	1

THE PILE COORDINATE SYSTEM (LOCAL AXES)

* PILE TOP DISPLACEMENTS *

PILE GROUP	DISP. x, M	DISP. y, M	DISP. z, M	ROT. x, RAD	ROT. y, RAD	ROT. z, RAD
*****	*****	*****	*****	*****	*****	*****
1	1.4106E-03	1.9629E-04	-4.3313E-04	-2.8747E-06	-5.4072E-05	-3.1630E-05
2	1.2683E-03	1.9629E-04	-4.2019E-04	-2.8747E-06	-5.4072E-05	-3.1630E-05
3	1.1259E-03	1.9629E-04	-4.0726E-04	-2.8747E-06	-5.4072E-05	-3.1630E-05
4	1.6539E-03	1.8335E-04	-4.3313E-04	-2.8747E-06	-5.4072E-05	-3.1630E-05

APPALTATORE: Consorzio  Soci  		ITINERARIO NAPOLI – BARI					
PROGETTAZIONE: Mandataria  Mandanti  		RADDOPPIO TRATTA APICE – ORSARA I LOTTO FUNZIONALE APICE – HIRPINIA					
PROGETTO ESECUTIVO RELAZIONE DI CALCOLO FONDAZIONI SPALLA A		COMMESSA IF1N	LOTTO 01 E ZZ	CODIFICA RG	DOCUMENTO MD0000 001	REV. B	FOGLIO 93 di 109

5	1.5116E-03	1.8335E-04	-4.2019E-04	-2.8747E-06	-5.4072E-05	-3.1630E-05
6	1.3693E-03	1.8335E-04	-4.0726E-04	-2.8747E-06	-5.4072E-05	-3.1630E-05
7	1.8972E-03	1.7041E-04	-4.3313E-04	-2.8747E-06	-5.4072E-05	-3.1630E-05
8	1.7549E-03	1.7041E-04	-4.2019E-04	-2.8747E-06	-5.4072E-05	-3.1630E-05
9	1.6126E-03	1.7041E-04	-4.0726E-04	-2.8747E-06	-5.4072E-05	-3.1630E-05
10	2.1406E-03	1.5748E-04	-4.3313E-04	-2.8747E-06	-5.4072E-05	-3.1630E-05
11	1.9982E-03	1.5748E-04	-4.2019E-04	-2.8747E-06	-5.4072E-05	-3.1630E-05
12	1.8559E-03	1.5748E-04	-4.0726E-04	-2.8747E-06	-5.4072E-05	-3.1630E-05
MINIMUM	1.1259E-03	1.5748E-04	-4.3313E-04	-2.8747E-06	-5.4072E-05	-3.1630E-05
Pile N.	3	10	1	1	1	1
MAXIMUM	2.1406E-03	1.9629E-04	-4.0726E-04	-2.8747E-06	-5.4072E-05	-3.1630E-05
Pile N.	10	1	3	1	1	1

* PILE TOP REACTIONS *

PILE GROUP	AXIAL, KN	LAT. y, KN	LAT. z, KN	MOM x, KN- M	MOM y, KN- M	MOM z, KN- M
*****	*****	*****	*****	*****	*****	*****
1	2772.9	62.811	-157.86	-0.7633	278.47	92.956
2	2502.7	54.196	-131.43	-0.7633	232.65	80.145
3	2232.5	60.226	-138.77	-0.7633	237.98	89.052
4	3234.9	53.462	-150.94	-0.7633	268.14	73.269
5	2964.6	45.455	-124.33	-0.7633	221.60	61.287
6	2694.4	50.761	-131.51	-0.7633	227.04	69.181
7	3696.8	48.771	-155.98	-0.7633	275.67	60.346
8	3426.6	41.747	-129.76	-0.7633	230.05	50.045
9	3156.4	46.591	-136.86	-0.7633	235.11	57.105
10	4158.7	54.501	-195.56	-0.7633	332.58	61.548
11	3888.5	50.660	-175.65	-0.7633	297.90	56.364
12	3618.3	53.818	-177.34	-0.7633	293.60	60.594
MINIMUM	2232.5	41.747	-195.56	-0.7633	221.60	50.045
Pile N.	3	8	10	1	5	8
MAXIMUM	4158.7	62.811	-124.33	-0.7633	332.58	92.956
Pile N.	10	1	5	1	10	1

PILE GROUP	STRESS, KN/ M**2
*****	*****
1	2455.2
2	2158.9
3	2030.2
4	2669.5
5	2371.6
6	2241.1
7	2943.6
8	2649.6
9	2516.3
10	3374.1
11	3115.5
12	2952.3
MINIMUM	2030.2
Pile N.	3
MAXIMUM	3374.1
Pile N.	10

* EFFECTS FOR LATERALLY LOADED PILE *

* MINIMUM VALUES AND LOCATIONS *

PILE	DISPL. y-DIR	DISPL. z-DIR	MOMENT z-DIR	MOMENT y-DIR	SHEAR y-DIR	SHEAR z-DIR	SOIL REACT y-DIR	SOIL REACT z-DIR	TOTAL STRESS	FLEX. RIG. z-DIR	FLEX. RIG. y-DIR
*****	*****	*****	*****	*****	*****	*****	*****	*****	*****	*****	*****
1	-4.0925E-06	-4.3313E-04	-92.956	-148.10	-15.863	-157.88	-8.4793	-43.742	1569.2	7.8279E+06	7.8279E+06
x(M)	8.6400	0.0000	0.0000	4.8600	7.0200	0.0000	10.260	3.5100	27.000	0.0000	0.0000
2	-3.7947E-06	-4.2019E-04	-80.145	-132.89	-14.116	-131.44	-7.4912	-36.190	1416.3	7.8279E+06	7.8279E+06
x(M)	8.9100	0.0000	0.0000	4.8600	7.2900	0.0000	10.260	3.5100	27.000	0.0000	0.0000
3	-3.9983E-06	-4.0726E-04	-89.052	-135.64	-15.199	-138.78	-8.1322	-39.056	1263.3	7.8279E+06	7.8279E+06
x(M)	8.6400	0.0000	0.0000	4.5900	7.0200	0.0000	10.260	3.5100	27.000	0.0000	0.0000
4	-3.8343E-06	-4.3313E-04	-73.269	-144.46	-14.297	-150.96	-7.5823	-41.728	1830.6	7.8279E+06	7.8279E+06
x(M)	8.6400	0.0000	0.0000	4.8600	7.0200	0.0000	10.260	3.5100	27.000	0.0000	0.0000
5	-3.5436E-06	-4.2019E-04	-61.287	-128.73	-12.644	-124.34	-6.6004	-34.094	1677.6	7.8279E+06	7.8279E+06
x(M)	8.9100	0.0000	0.0000	4.8600	7.2900	0.0000	10.260	3.5100	27.000	0.0000	0.0000
6	-3.7267E-06	-4.0726E-04	-69.181	-131.66	-13.614	-131.52	-7.2075	-36.922	1524.7	7.8279E+06	7.8279E+06
x(M)	8.6400	0.0000	0.0000	4.8600	7.0200	0.0000	10.260	3.5100	27.000	0.0000	0.0000
7	-3.7170E-06	-4.3313E-04	-60.346	-146.90	-13.678	-155.99	-7.1339	-43.382	2091.9	7.8279E+06	7.8279E+06
x(M)	8.6400	0.0000	0.0000	4.8600	6.7500	0.0000	10.260	3.5100	27.000	0.0000	0.0000
8	-3.4940E-06	-4.2019E-04	-50.045	-131.71	-12.188	-129.77	-6.3659	-35.877	1939.0	7.8279E+06	7.8279E+06
x(M)	8.9100	0.0000	0.0000	4.8600	7.0200	0.0000	10.260	3.5100	27.000	0.0000	0.0000
9	-3.6683E-06	-4.0726E-04	-57.105	-134.32	-13.099	-136.87	-6.8553	-38.692	1786.1	7.8279E+06	7.8279E+06
x(M)	8.6400	0.0000	0.0000	4.8600	7.0200	0.0000	10.260	3.5100	27.000	0.0000	0.0000
10	-3.8192E-06	-4.3313E-04	-61.548	-166.84	-15.301	-195.59	-7.1506	-55.620	2353.3	7.8279E+06	7.8279E+06
x(M)	8.1000	0.0000	0.0000	4.5900	6.4800	0.0000	10.260	3.2400	27.000	0.0000	0.0000
11	-3.7714E-06	-4.2019E-04	-56.364	-155.75	-14.456	-175.67	-7.0004	-50.128	2200.4	7.8279E+06	7.8279E+06
x(M)	8.1000	0.0000	0.0000	4.5900	6.4800	0.0000	10.260	3.5100	27.000	0.0000	0.0000
12	-3.8298E-06	-4.0726E-04	-60.594	-154.98	-15.022	-177.36	-7.0934	-51.296	2047.5	7.8279E+06	7.8279E+06
x(M)	8.1000	0.0000	0.0000	4.3200	6.4800	0.0000	10.260	3.2400	27.000	0.0000	0.0000

APPALTATORE: Consorzio Soci 	<h2 style="margin:0;">ITINERARIO NAPOLI – BARI</h2> <h3 style="margin:0;">RADDOPPIO TRATTA APICE – ORSARA</h3> <h3 style="margin:0;">I LOTTO FUNZIONALE APICE – HIRPINIA</h3>												
PROGETTAZIONE: Mandataria Mandanti 													
PROGETTO ESECUTIVO RELAZIONE DI CALCOLO FONDAZIONI SPALLA A	<table style="width:100%; border-collapse: collapse;"> <tr> <td style="width:12.5%;">COMMESSA</td> <td style="width:12.5%;">LOTTO</td> <td style="width:12.5%;">CODIFICA</td> <td style="width:12.5%;">DOCUMENTO</td> <td style="width:12.5%;">REV.</td> <td style="width:12.5%;">FOGLIO</td> </tr> <tr> <td>IF1N</td> <td>01 E ZZ</td> <td>RG</td> <td>MD0000 001</td> <td>B</td> <td>94 di 109</td> </tr> </table>	COMMESSA	LOTTO	CODIFICA	DOCUMENTO	REV.	FOGLIO	IF1N	01 E ZZ	RG	MD0000 001	B	94 di 109
COMMESSA	LOTTO	CODIFICA	DOCUMENTO	REV.	FOGLIO								
IF1N	01 E ZZ	RG	MD0000 001	B	94 di 109								

Min.	-4.0925E-06	-4.3313E-04	-92.956	-166.84	-15.863	-195.59	-8.4793	-55.620	1263.3	7.8279E+06	7.8279E+06
Pile N.	1	1	1	10	1	10	1	10	3	1	1

* MAXIMUM VALUES AND LOCATIONS *

PILE	DISPL.		MOMENT		SHEAR		SOIL REACT		TOTAL STRESS	FLEX. RIG.	
	y-Dir	z-Dir	z-Dir	y-Dir	y-Dir	z-Dir	y-Dir	z-Dir		z-Dir	y-Dir
	M	M	KN- M	KN- M	KN	KN	KN/ M	KN/ M	KN/ M**2	KN- M**2	KN- M**2
1	1.9629E-04	8.4625E-06	67.784	278.47	62.815	35.083	17.945	19.281	2455.2	7.8279E+06	7.8279E+06
x(M)	0.0000	8.9100	4.5900	0.0000	0.0000	7.2900	3.5100	10.260	0.0000	0.0000	0.0000
2	1.9629E-04	7.5367E-06	62.851	232.65	54.200	30.258	15.439	16.176	2158.9	7.8279E+06	7.8279E+06
x(M)	0.0000	9.1800	4.5900	0.0000	0.0000	7.5600	3.5100	10.260	0.0000	0.0000	0.0000
3	1.9629E-04	7.8563E-06	66.083	237.98	60.230	31.562	17.393	17.180	2030.2	7.8279E+06	7.8279E+06
x(M)	0.0000	8.9100	4.5900	0.0000	0.0000	7.2900	3.5100	10.260	0.0000	0.0000	0.0000
4	1.8335E-04	8.2411E-06	62.203	268.14	53.466	33.778	15.456	18.488	2669.5	7.8279E+06	7.8279E+06
x(M)	0.0000	8.9100	4.3200	0.0000	0.0000	7.2900	3.5100	10.260	0.0000	0.0000	0.0000
5	1.8335E-04	7.2381E-06	57.419	221.60	45.458	28.911	13.123	15.127	2371.6	7.8279E+06	7.8279E+06
x(M)	0.0000	9.1800	4.5900	0.0000	0.0000	7.5600	3.5100	10.260	0.0000	0.0000	0.0000
6	1.8335E-04	7.5703E-06	60.340	227.04	50.765	30.150	14.842	16.279	2241.1	7.8279E+06	7.8279E+06
x(M)	0.0000	8.9100	4.3200	0.0000	0.0000	7.2900	3.5100	10.260	0.0000	0.0000	0.0000
7	1.7042E-04	8.4120E-06	59.382	275.67	48.775	34.644	14.366	19.008	2943.6	7.8279E+06	7.8279E+06
x(M)	0.0000	8.9100	4.3200	0.0000	0.0000	7.2900	3.2400	10.260	0.0000	0.0000	0.0000
8	1.7042E-04	7.4751E-06	55.158	230.05	41.750	29.868	12.331	15.866	2649.6	7.8279E+06	7.8279E+06
x(M)	0.0000	9.1800	4.3200	0.0000	0.0000	7.5600	3.5100	10.260	0.0000	0.0000	0.0000
9	1.7042E-04	7.7908E-06	57.898	235.11	46.595	31.104	13.892	16.881	2516.3	7.8279E+06	7.8279E+06
x(M)	0.0000	8.9100	4.3200	0.0000	0.0000	7.2900	3.5100	10.260	0.0000	0.0000	0.0000
10	1.5748E-04	9.5040E-06	62.430	332.58	54.505	41.819	16.763	21.985	3374.1	7.8279E+06	7.8279E+06
x(M)	0.0000	8.3700	4.0500	0.0000	0.0000	6.7500	10.260	2.7000	0.0000	0.0000	0.0000
11	1.5748E-04	8.9435E-06	60.291	297.90	50.663	38.091	15.569	20.466	3115.5	7.8279E+06	7.8279E+06
x(M)	0.0000	8.6400	4.0500	0.0000	0.0000	7.0200	2.9700	10.260	0.0000	0.0000	0.0000
12	1.5748E-04	8.9652E-06	61.867	293.60	53.822	38.445	16.711	20.174	2952.3	7.8279E+06	7.8279E+06
x(M)	0.0000	8.3700	4.0500	0.0000	0.0000	6.7500	2.9700	10.260	0.0000	0.0000	0.0000
Max.	1.9629E-04	9.5040E-06	67.784	332.58	62.815	41.819	17.945	21.985	3374.1	7.8279E+06	7.8279E+06
Pile N.	1	10	1	10	1	10	1	10	10	1	1

LOAD CASE : 15
CASE NAME : Load Case
LOAD TYPE : Special, Sp

REDUCTION FACTORS FOR CLOSELY-SPACED PILE GROUPS, COMBINED Y AND Z DIRECTIONS
ESTIMATED USING MOVEMENT IN THE DIRECTION OF PILE CAP DISPLACEMENTS

GROUP NO	P-FACTOR	Y-FACTOR
1	0.7644	1.0000
2	0.5471	1.0000
3	0.5845	1.0000
4	0.7111	1.0000
5	0.4821	1.0000
6	0.5159	1.0000
7	0.7221	1.0000
8	0.4955	1.0000
9	0.5310	1.0000
10	0.8661	1.0000
11	0.6800	1.0000
12	0.7123	1.0000

* TABLE L * COMPUTATION ON PILE CAP

* EQUIVALENT CONCENTRATED LOAD AT ORIGIN *

VERT. LOAD, KN	HOR. LOAD Y, KN	HOR. LOAD Z, KN
54209.3	2021.00	-1743.00
MOMENT X, KN- M	MOMENT Y, KN- M	MOMENT Z, KN- M
-382.000	-37556.5	-24825.5

* DISPLACEMENT OF GROUPED PILE FOUNDATION AT ORIGIN *

VERTICAL, M	HORIZONTAL Y, M	HORIZONTAL Z, M
2.32954E-03	5.84590E-04	-4.83044E-04
ANGLE ROT. X, RAD	ANGLE ROT. Y, RAD	ANGLE ROT. Z, RAD
-1.70383E-06	-7.00951E-05	-9.08900E-05

THE GLOBAL STRUCTURAL COORDINATE SYSTEM

APPALTATORE:

Consorzio

Soci



ITINERARIO NAPOLI – BARI

PROGETTAZIONE:

Mandatario

Mandanti



RADDOPPIO TRATTA APICE – ORSARA
I LOTTO FUNZIONALE APICE – HIRPINIA

PROGETTO ESECUTIVO

RELAZIONE DI CALCOLO FONDAZIONI SPALLA A

COMMESSA
IF1N

LOTTO
01 E ZZ

CODIFICA
RG

DOCUMENTO
MD0000 001

REV.
B

FOGLIO
95 di 109

* PILE TOP DISPLACEMENTS *

PILE GROUP	DISP. X, M	DISP. Y, M	DISP. Z, M	ROT. X,RAD	ROT. Y,RAD	ROT. Z,RAD
*****	*****	*****	*****	*****	*****	*****
1	2.2654E-03	5.9609E-04	-4.9071E-04	-1.7038E-06	-7.0095E-05	-9.0890E-05
2	1.8564E-03	5.9609E-04	-4.8304E-04	-1.7038E-06	-7.0095E-05	-9.0890E-05
3	1.4474E-03	5.9609E-04	-4.7538E-04	-1.7038E-06	-7.0095E-05	-9.0890E-05
4	2.5808E-03	5.8842E-04	-4.9071E-04	-1.7038E-06	-7.0095E-05	-9.0890E-05
5	2.1718E-03	5.8842E-04	-4.8304E-04	-1.7038E-06	-7.0095E-05	-9.0890E-05
6	1.7628E-03	5.8842E-04	-4.7538E-04	-1.7038E-06	-7.0095E-05	-9.0890E-05
7	2.8963E-03	5.8076E-04	-4.9071E-04	-1.7038E-06	-7.0095E-05	-9.0890E-05
8	2.4872E-03	5.8076E-04	-4.8304E-04	-1.7038E-06	-7.0095E-05	-9.0890E-05
9	2.0782E-03	5.8076E-04	-4.7538E-04	-1.7038E-06	-7.0095E-05	-9.0890E-05
10	3.2117E-03	5.7309E-04	-4.9071E-04	-1.7038E-06	-7.0095E-05	-9.0890E-05
11	2.8027E-03	5.7309E-04	-4.8304E-04	-1.7038E-06	-7.0095E-05	-9.0890E-05
12	2.3937E-03	5.7309E-04	-4.7538E-04	-1.7038E-06	-7.0095E-05	-9.0890E-05
MINIMUM	1.4474E-03	5.7309E-04	-4.9071E-04	-1.7038E-06	-7.0095E-05	-9.0890E-05
Pile N.	3	10	1	1	1	1
MAXIMUM	3.2117E-03	5.9609E-04	-4.7538E-04	-1.7038E-06	-7.0095E-05	-9.0890E-05
Pile N.	10	1	3	1	1	1

* PILE TOP REACTIONS *

PILE GROUP	FOR. X, KN	FOR. Y, KN	FOR. Z, KN	MOM X, KN- M	MOM Y, KN- M	MOM Z, KN- M
*****	*****	*****	*****	*****	*****	*****
1	4395.7	197.14	-168.13	-0.4524	276.48	308.80
2	3619.2	157.13	-131.22	-0.4524	217.52	248.96
3	2842.8	164.93	-134.21	-0.4524	218.67	260.75
4	4994.5	184.30	-160.57	-0.4524	265.49	286.55
5	4218.0	141.25	-120.67	-0.4524	201.03	221.05
6	3441.6	148.50	-123.55	-0.4524	202.26	232.25
7	5593.3	182.88	-162.66	-0.4524	268.64	280.92
8	4816.8	141.22	-123.27	-0.4524	205.22	217.91
9	4040.4	148.65	-126.35	-0.4524	206.69	229.31
10	6192.1	203.46	-184.27	-0.4524	299.86	306.61
11	5415.6	172.69	-153.31	-0.4524	251.21	262.32
12	4639.2	178.86	-154.79	-0.4524	249.67	271.20
MINIMUM	2842.8	141.22	-184.27	-0.4524	201.03	217.91
Pile N.	3	8	10	1	5	8
MAXIMUM	6192.1	203.46	-120.67	-0.4524	299.86	308.80
Pile N.	10	10	5	1	10	1

THE PILE COORDINATE SYSTEM (LOCAL AXES)

* PILE TOP DISPLACEMENTS *

PILE GROUP	DISP. x, M	DISP. y, M	DISP. z, M	ROT. x,RAD	ROT. y,RAD	ROT. z,RAD
*****	*****	*****	*****	*****	*****	*****
1	2.2654E-03	5.9609E-04	-4.9071E-04	-1.7038E-06	-7.0095E-05	-9.0890E-05
2	1.8564E-03	5.9609E-04	-4.8304E-04	-1.7038E-06	-7.0095E-05	-9.0890E-05
3	1.4474E-03	5.9609E-04	-4.7538E-04	-1.7038E-06	-7.0095E-05	-9.0890E-05
4	2.5808E-03	5.8842E-04	-4.9071E-04	-1.7038E-06	-7.0095E-05	-9.0890E-05
5	2.1718E-03	5.8842E-04	-4.8304E-04	-1.7038E-06	-7.0095E-05	-9.0890E-05
6	1.7628E-03	5.8842E-04	-4.7538E-04	-1.7038E-06	-7.0095E-05	-9.0890E-05
7	2.8963E-03	5.8076E-04	-4.9071E-04	-1.7038E-06	-7.0095E-05	-9.0890E-05
8	2.4872E-03	5.8076E-04	-4.8304E-04	-1.7038E-06	-7.0095E-05	-9.0890E-05
9	2.0782E-03	5.8076E-04	-4.7538E-04	-1.7038E-06	-7.0095E-05	-9.0890E-05
10	3.2117E-03	5.7309E-04	-4.9071E-04	-1.7038E-06	-7.0095E-05	-9.0890E-05
11	2.8027E-03	5.7309E-04	-4.8304E-04	-1.7038E-06	-7.0095E-05	-9.0890E-05
12	2.3937E-03	5.7309E-04	-4.7538E-04	-1.7038E-06	-7.0095E-05	-9.0890E-05
MINIMUM	1.4474E-03	5.7309E-04	-4.9071E-04	-1.7038E-06	-7.0095E-05	-9.0890E-05
Pile N.	3	10	1	1	1	1
MAXIMUM	3.2117E-03	5.9609E-04	-4.7538E-04	-1.7038E-06	-7.0095E-05	-9.0890E-05
Pile N.	10	1	3	1	1	1

* PILE TOP REACTIONS *

PILE GROUP	AXIAL, KN	LAT. y, KN	LAT. z, KN	MOM x, KN- M	MOM y, KN- M	MOM z, KN- M
*****	*****	*****	*****	*****	*****	*****
1	4395.7	197.14	-168.13	-0.4524	276.48	308.80
2	3619.2	157.13	-131.22	-0.4524	217.52	248.96
3	2842.8	164.93	-134.21	-0.4524	218.67	260.75
4	4994.5	184.30	-160.57	-0.4524	265.49	286.55
5	4218.0	141.25	-120.67	-0.4524	201.03	221.05
6	3441.6	148.50	-123.55	-0.4524	202.26	232.25
7	5593.3	182.88	-162.66	-0.4524	268.64	280.92
8	4816.8	141.22	-123.27	-0.4524	205.22	217.91
9	4040.4	148.65	-126.35	-0.4524	206.69	229.31
10	6192.1	203.46	-184.27	-0.4524	299.86	306.61
11	5415.6	172.69	-153.31	-0.4524	251.21	262.32
12	4639.2	178.86	-154.79	-0.4524	249.67	271.20

APPALTATORE:

Consorzio

Soci



ITINERARIO NAPOLI – BARI

PROGETTAZIONE:

Mandatario

Mandanti



RADDOPPIO TRATTA APICE – ORSARA
I LOTTO FUNZIONALE APICE – HIRPINIA

PROGETTO ESECUTIVO

RELAZIONE DI CALCOLO FONDAZIONI SPALLA A

COMMESSA
IF1N

LOTTO
01 E ZZ

CODIFICA
RG

DOCUMENTO
MD0000 001

REV.
B

FOGLIO
96 di 109

MINIMUM	2842.8	141.22	-184.27	-0.4524	201.03	217.91
Pile N.	3	8	10	1	5	8
MAXIMUM	6192.1	203.46	-120.67	-0.4524	299.86	308.80
Pile N.	10	10	5	1	10	1

PILE GROUP STRESS, KN/ M**2

*****	*****
1	3738.4
2	3045.8
3	2635.7
4	4005.2
5	3288.7
6	2877.0
7	4338.3
8	3629.2
9	3218.1
10	4798.4
11	4160.8
12	3737.8

MINIMUM	2635.7
Pile N.	3
MAXIMUM	4798.4
Pile N.	10

* EFFECTS FOR LATERALLY LOADED PILE *

* MINIMUM VALUES AND LOCATIONS *

PILE	DISPL. y-DIR M	DISPL. z-DIR M	MOMENT z-DIR KN- M	MOMENT y-DIR KN- M	SHEAR y-DIR KN	SHEAR z-DIR KN	SOIL REACT y-DIR KN/ M	SOIL REACT z-DIR KN/ M	TOTAL STRESS KN/ M**2	FLEX. RIG. z-DIR KN- M**2	FLEX. RIG. y-DIR KN- M**2
*****	*****	*****	*****	*****	*****	*****	*****	*****	*****	*****	*****
1	-1.2110E-05	-4.9071E-04	-308.80	-174.16	-51.808	-168.15	-28.067	-45.262	2487.4	7.8279E+06	7.8279E+06
x (M)	8.6400	0.0000	0.0000	4.5900	7.0200	0.0000	10.260	3.7800	27.000	0.0000	0.0000
2	-1.0807E-05	-4.8304E-04	-248.96	-152.63	-43.383	-131.23	-23.504	-35.527	2048.1	7.8279E+06	7.8279E+06
x (M)	8.9100	0.0000	0.0000	4.8600	7.2900	0.0000	10.260	4.3200	27.000	0.0000	0.0000
3	-1.1117E-05	-4.7538E-04	-260.75	-153.80	-44.958	-134.22	-24.513	-36.305	1608.7	7.8279E+06	7.8279E+06
x (M)	8.9100	0.0000	0.0000	4.8600	7.2900	0.0000	10.260	4.3200	27.000	0.0000	0.0000
4	-1.1783E-05	-4.9071E-04	-286.55	-169.87	-49.256	-160.59	-26.824	-43.205	2826.3	7.8279E+06	7.8279E+06
x (M)	8.6400	0.0000	0.0000	4.5900	7.0200	0.0000	10.260	3.7800	27.000	0.0000	0.0000
5	-1.0243E-05	-4.8304E-04	-221.05	-146.12	-40.223	-120.68	-21.226	-32.888	2386.9	7.8279E+06	7.8279E+06
x (M)	9.1800	0.0000	0.0000	4.8600	7.5600	0.0000	10.260	4.3200	27.000	0.0000	0.0000
6	-1.0501E-05	-4.7538E-04	-232.25	-147.47	-41.601	-123.56	-22.297	-33.688	1947.5	7.8279E+06	7.8279E+06
x (M)	9.1800	0.0000	0.0000	4.8600	7.5600	0.0000	10.260	4.3200	27.000	0.0000	0.0000
7	-1.1749E-05	-4.9071E-04	-280.92	-171.03	-49.067	-162.69	-26.608	-43.867	3165.2	7.8279E+06	7.8279E+06
x (M)	8.6400	0.0000	0.0000	4.5900	7.0200	0.0000	10.260	3.7800	27.000	0.0000	0.0000
8	-1.0291E-05	-4.8304E-04	-217.91	-147.71	-40.280	-123.29	-21.398	-33.643	2725.8	7.8279E+06	7.8279E+06
x (M)	9.1800	0.0000	0.0000	4.8600	7.5600	0.0000	10.260	4.3200	27.000	0.0000	0.0000
9	-1.0565E-05	-4.7538E-04	-229.31	-149.12	-41.707	-126.36	-22.456	-34.485	2286.4	7.8279E+06	7.8279E+06
x (M)	8.9100	0.0000	0.0000	4.8600	7.2900	0.0000	10.260	4.3200	27.000	0.0000	0.0000
10	-1.2236E-05	-4.9071E-04	-306.61	-182.69	-53.489	-184.30	-27.928	-50.211	3504.0	7.8279E+06	7.8279E+06
x (M)	8.3700	0.0000	0.0000	4.5900	7.0200	0.0000	10.260	3.5100	27.000	0.0000	0.0000
11	-1.1466E-05	-4.8304E-04	-262.32	-165.15	-46.948	-153.33	-25.509	-41.457	3064.6	7.8279E+06	7.8279E+06
x (M)	8.6400	0.0000	0.0000	4.5900	7.0200	0.0000	10.260	3.7800	27.000	0.0000	0.0000
12	-1.1638E-05	-4.7538E-04	-271.20	-165.51	-48.145	-154.81	-26.046	-42.038	2625.2	7.8279E+06	7.8279E+06
x (M)	8.6400	0.0000	0.0000	4.5900	7.0200	0.0000	10.260	3.7800	27.000	0.0000	0.0000
Min.	-1.2236E-05	-4.9071E-04	-308.80	-182.69	-53.489	-184.30	-28.067	-50.211	1608.7	7.8279E+06	7.8279E+06
Pile N.	10	1	1	10	10	10	1	10	3	1	1

* MAXIMUM VALUES AND LOCATIONS *

PILE	DISPL. y-DIR M	DISPL. z-DIR M	MOMENT z-DIR KN- M	MOMENT y-DIR KN- M	SHEAR y-DIR KN	SHEAR z-DIR KN	SOIL REACT y-DIR KN/ M	SOIL REACT z-DIR KN/ M	TOTAL STRESS KN/ M**2	FLEX. RIG. z-DIR KN- M**2	FLEX. RIG. y-DIR KN- M**2
*****	*****	*****	*****	*****	*****	*****	*****	*****	*****	*****	*****
1	5.9609E-04	9.8543E-06	211.83	276.48	197.16	42.742	53.491	23.375	3738.4	7.8279E+06	7.8279E+06
x (M)	0.0000	8.6400	4.5900	0.0000	0.0000	7.0200	3.5100	10.260	0.0000	0.0000	0.0000
2	5.9609E-04	8.6063E-06	188.58	217.52	157.15	35.204	42.708	19.107	3045.8	7.8279E+06	7.8279E+06
x (M)	0.0000	9.1800	4.8600	0.0000	0.0000	7.5600	4.3200	10.260	0.0000	0.0000	0.0000
3	5.9609E-04	8.7761E-06	192.93	218.67	164.95	35.871	44.716	19.609	2635.7	7.8279E+06	7.8279E+06
x (M)	0.0000	8.9100	4.8600	0.0000	0.0000	7.2900	4.3200	10.260	0.0000	0.0000	0.0000
4	5.8842E-04	9.6474E-06	204.21	265.49	184.32	41.119	50.044	22.648	4005.2	7.8279E+06	7.8279E+06
x (M)	0.0000	8.6400	4.5900	0.0000	0.0000	7.0200	3.7800	10.260	0.0000	0.0000	0.0000
5	5.8842E-04	8.2139E-06	178.56	201.03	141.26	33.049	38.739	17.432	3288.7	7.8279E+06	7.8279E+06
x (M)	0.0000	9.1800	4.8600	0.0000	0.0000	7.5600	4.3200	10.260	0.0000	0.0000	0.0000
6	5.8842E-04	8.3653E-06	182.85	202.26	148.52	33.665	40.661	18.047	2877.0	7.8279E+06	7.8279E+06
x (M)	0.0000	9.1800	4.8600	0.0000	0.0000	7.5600	4.3200	10.260	0.0000	0.0000	0.0000
7	5.8076E-04	9.7281E-06	202.96	268.64	182.91	41.529	49.839	22.822	4338.3	7.8279E+06	7.8279E+06
x (M)	0.0000	8.6400	4.5900	0.0000	0.0000	7.0200	3.7800	10.260	0.0000	0.0000	0.0000
8	5.8076E-04	8.3404E-06	178.19	205.22	141.23	33.564	38.822	17.826	3629.2	7.8279E+06	7.8279E+06
x (M)	0.0000	9.1800	4.8600	0.0000	0.0000	7.5600	4.3200	10.260	0.0000	0.0000	0.0000
9	5.8076E-04	8.4716E-06	182.50	206.69	148.66	34.186	40.776	18.439	3218.1	7.8279E+06	7.8279E+06
x (M)	0.0000	9.1800	4.8600	0.0000	0.0000	7.5600	4.3200	10.260	0.0000	0.0000	0.0000
10	5.7309E-04	1.0279E-05	213.25	299.86	203.49	45.850	56.197	24.462	4798.4	7.8279E+06	7.8279E+06
x (M)	0.0000	8.3700	4.5900	0.0000	0.0000	6.7500	3.2400	10.260	0.0000	0.0000	0.0000

APPALTATORE: Consorzio Soci   				ITINERARIO NAPOLI – BARI RADDOPPIO TRATTA APICE – ORSARA I LOTTO FUNZIONALE APICE – HIRPINIA					
PROGETTAZIONE: Mandataria Mandanti   									
PROGETTO ESECUTIVO RELAZIONE DI CALCOLO FONDAZIONI SPALLA A									

11	5.7309E-04	9.4303E-06	196.64	251.21	172.71	39.575	47.221	21.785	4160.8	7.8279E+06	7.8279E+06
x(M)	0.0000	8.6400	4.5900	0.0000	0.0000	7.0200	3.7800	10.260	0.0000	0.0000	0.0000
12	5.7309E-04	9.4902E-06	199.99	249.67	178.88	39.982	49.000	21.865	3737.8	7.8279E+06	7.8279E+06
x(M)	0.0000	8.6400	4.5900	0.0000	0.0000	7.0200	3.7800	10.260	0.0000	0.0000	0.0000
Max.	5.9609E-04	1.0279E-05	213.25	299.86	203.49	45.850	56.197	24.462	4798.4	7.8279E+06	7.8279E+06
Pile N.	1	10	10	10	10	10	10	10	10	1	1

LOAD CASE : 16
CASE NAME : Load Case
LOAD TYPE : Special, Sp

REDUCTION FACTORS FOR CLOSELY-SPACED PILE GROUPS, COMBINED Y AND Z DIRECTIONS
ESTIMATED USING MOVEMENT IN THE DIRECTION OF PILE CAP DISPLACEMENTS

GROUP NO	P-FACTOR	Y-FACTOR
1	0.8504	1.0000
2	0.5740	1.0000
3	0.5845	1.0000
4	0.7908	1.0000
5	0.4930	1.0000
6	0.4989	1.0000
7	0.7924	1.0000
8	0.4952	1.0000
9	0.5015	1.0000
10	0.8661	1.0000
11	0.5966	1.0000
12	0.6071	1.0000

* TABLE L * COMPUTATION ON PILE CAP

* EQUIVALENT CONCENTRATED LOAD AT ORIGIN *

VERT. LOAD, KN	HOR. LOAD Y, KN	HOR. LOAD Z, KN
56653.3	5158.00	-1498.00
MOMENT X, KN- M	MOMENT Y, KN- M	MOMENT Z, KN- M
-716.000	-24450.0	-61609.0

* DISPLACEMENT OF GROUPED PILE FOUNDATION AT ORIGIN *

VERTICAL, M	HORIZONTAL Y, M	HORIZONTAL Z, M
2.47314E-03	1.95722E-03	-5.19897E-04
ANGLE ROT. X, RAD	ANGLE ROT. Y, RAD	ANGLE ROT. Z, RAD
-1.84463E-06	-5.34183E-05	-2.43791E-04







THE GLOBAL STRUCTURAL COORDINATE SYSTEM

* PILE TOP DISPLACEMENTS *

PILE GROUP	DISP. X, M	DISP. Y, M	DISP. Z, M	ROT. X, RAD	ROT. Y, RAD	ROT. Z, RAD
*****	*****	*****	*****	*****	*****	*****
1	3.2096E-03	1.9697E-03	-5.2820E-04	-1.8446E-06	-5.3418E-05	-2.4379E-04
2	2.1126E-03	1.9697E-03	-5.1990E-04	-1.8446E-06	-5.3418E-05	-2.4379E-04
3	1.0155E-03	1.9697E-03	-5.1160E-04	-1.8446E-06	-5.3418E-05	-2.4379E-04
4	3.4500E-03	1.9614E-03	-5.2820E-04	-1.8446E-06	-5.3418E-05	-2.4379E-04
5	2.3529E-03	1.9614E-03	-5.1990E-04	-1.8446E-06	-5.3418E-05	-2.4379E-04
6	1.2559E-03	1.9614E-03	-5.1160E-04	-1.8446E-06	-5.3418E-05	-2.4379E-04
7	3.6904E-03	1.9531E-03	-5.2820E-04	-1.8446E-06	-5.3418E-05	-2.4379E-04
8	2.5933E-03	1.9531E-03	-5.1990E-04	-1.8446E-06	-5.3418E-05	-2.4379E-04
9	1.4963E-03	1.9531E-03	-5.1160E-04	-1.8446E-06	-5.3418E-05	-2.4379E-04
10	3.9308E-03	1.9448E-03	-5.2820E-04	-1.8446E-06	-5.3418E-05	-2.4379E-04
11	2.8337E-03	1.9448E-03	-5.1990E-04	-1.8446E-06	-5.3418E-05	-2.4379E-04
12	1.7367E-03	1.9448E-03	-5.1160E-04	-1.8446E-06	-5.3418E-05	-2.4379E-04
MINIMUM	1.0155E-03	1.9448E-03	-5.2820E-04	-1.8446E-06	-5.3418E-05	-2.4379E-04
Pile N.	3	10	1	1	1	1
MAXIMUM	3.9308E-03	1.9697E-03	-5.1160E-04	-1.8446E-06	-5.3418E-05	-2.4379E-04
Pile N.	10	1	3	1	1	1

* PILE TOP REACTIONS *

PILE GROUP	FOR. X, KN	FOR. Y, KN	FOR. Z, KN	MOM X, KN- M	MOM Y, KN- M	MOM Z, KN- M
*****	*****	*****	*****	*****	*****	*****
1	6188.2	535.89	-156.11	-0.4898	316.62	987.59
2	4105.6	403.14	-116.05	-0.4898	245.23	763.61

APPALTATORE: Consorzio  Soci  		ITINERARIO NAPOLI – BARI RADDOPPIO TRATTA APICE – ORSARA I LOTTO FUNZIONALE APICE – HIRPINIA					
PROGETTAZIONE: Mandataria  Mandanti  							
PROGETTO ESECUTIVO RELAZIONE DI CALCOLO FONDAZIONI SPALLA A							

3	2022.9	409.27	-115.11	-0.4898	240.53	773.04
4	6521.0	506.11	-148.63	-0.4898	304.36	936.27
5	4561.9	358.42	-104.29	-0.4898	224.15	681.90
6	2479.3	362.25	-102.97	-0.4898	218.85	687.51
7	6825.0	504.49	-149.07	-0.4898	305.16	930.70
8	5018.2	357.77	-104.78	-0.4898	225.13	678.47
9	2935.6	361.80	-103.50	-0.4898	219.91	684.42
10	7129.1	535.49	-158.86	-0.4898	321.31	977.94
11	5474.6	408.70	-119.83	-0.4898	252.17	765.95
12	3391.9	414.67	-118.79	-0.4898	247.27	774.99
MINIMUM	2022.9	357.77	-158.86	-0.4898	218.85	678.47
Pile N.	3	8	10	1	6	8
MAXIMUM	7129.1	535.89	-102.97	-0.4898	321.31	987.59
Pile N.	10	1	6	1	10	1

THE PILE COORDINATE SYSTEM (LOCAL AXES)

* PILE TOP DISPLACEMENTS *

PILE GROUP	DISP. x, M	DISP. y, M	DISP. z, M	ROT. x,RAD	ROT. y,RAD	ROT. z,RAD
1	3.2096E-03	1.9697E-03	-5.2820E-04	-1.8446E-06	-5.3418E-05	-2.4379E-04
2	2.1126E-03	1.9697E-03	-5.1990E-04	-1.8446E-06	-5.3418E-05	-2.4379E-04
3	1.0155E-03	1.9697E-03	-5.1160E-04	-1.8446E-06	-5.3418E-05	-2.4379E-04
4	3.4500E-03	1.9614E-03	-5.2820E-04	-1.8446E-06	-5.3418E-05	-2.4379E-04
5	2.3529E-03	1.9614E-03	-5.1990E-04	-1.8446E-06	-5.3418E-05	-2.4379E-04
6	1.2559E-03	1.9614E-03	-5.1160E-04	-1.8446E-06	-5.3418E-05	-2.4379E-04
7	3.6904E-03	1.9531E-03	-5.2820E-04	-1.8446E-06	-5.3418E-05	-2.4379E-04
8	2.5933E-03	1.9531E-03	-5.1990E-04	-1.8446E-06	-5.3418E-05	-2.4379E-04
9	1.4963E-03	1.9531E-03	-5.1160E-04	-1.8446E-06	-5.3418E-05	-2.4379E-04
10	3.9308E-03	1.9448E-03	-5.2820E-04	-1.8446E-06	-5.3418E-05	-2.4379E-04
11	2.8337E-03	1.9448E-03	-5.1990E-04	-1.8446E-06	-5.3418E-05	-2.4379E-04
12	1.7367E-03	1.9448E-03	-5.1160E-04	-1.8446E-06	-5.3418E-05	-2.4379E-04
MINIMUM	1.0155E-03	1.9448E-03	-5.2820E-04	-1.8446E-06	-5.3418E-05	-2.4379E-04
Pile N.	3	10	1	1	1	1
MAXIMUM	3.9308E-03	1.9697E-03	-5.1160E-04	-1.8446E-06	-5.3418E-05	-2.4379E-04
Pile N.	10	1	3	1	1	1

* PILE TOP REACTIONS *

PILE GROUP	AXIAL, KN	LAT. y, KN	LAT. z, KN	MOM x, KN- M	MOM y, KN- M	MOM z, KN- M
1	6188.2	535.89	-156.11	-0.4898	316.62	987.59
2	4105.6	403.14	-116.05	-0.4898	245.23	763.61
3	2022.9	409.27	-115.11	-0.4898	240.53	773.04
4	6521.0	506.11	-148.63	-0.4898	304.36	936.27
5	4561.9	358.42	-104.29	-0.4898	224.15	681.90
6	2479.3	362.25	-102.97	-0.4898	218.85	687.51
7	6825.0	504.49	-149.07	-0.4898	305.16	930.70
8	5018.2	357.77	-104.78	-0.4898	225.13	678.47
9	2935.6	361.80	-103.50	-0.4898	219.91	684.42
10	7129.1	535.49	-158.86	-0.4898	321.31	977.94
11	5474.6	408.70	-119.83	-0.4898	252.17	765.95
12	3391.9	414.67	-118.79	-0.4898	247.27	774.99
MINIMUM	2022.9	357.77	-158.86	-0.4898	218.85	678.47
Pile N.	3	8	10	1	6	8
MAXIMUM	7129.1	535.89	-102.97	-0.4898	321.31	987.59
Pile N.	10	1	6	1	10	1

PILE GROUP	STRESS, KN/ M**2
1	6631.8
2	4743.8
3	3588.1
4	6661.4
5	4747.8
6	3580.5
7	6818.2
8	4997.2
9	3830.8
10	7140.9
11	5531.7
12	4374.6
MINIMUM	3580.5
Pile N.	6
MAXIMUM	7140.9
Pile N.	10

* EFFECTS FOR LATERALLY LOADED PILE *

* MINIMUM VALUES AND LOCATIONS *

APPALTATORE:

Consorzio

Soci



ITINERARIO NAPOLI – BARI

PROGETTAZIONE:

Mandatario

Mandanti



RADDOPPIO TRATTA APICE – ORSARA
I LOTTO FUNZIONALE APICE – HIRPINIA

PROGETTO ESECUTIVO

RELAZIONE DI CALCOLO FONDAZIONI SPALLA A

COMMESSA IF1N	LOTTO 01 E ZZ	CODIFICA RG	DOCUMENTO MD0000 001	REV. B	FOGLIO 99 di 109
------------------	------------------	----------------	-------------------------	-----------	---------------------

PILE	DISPL. y-DIR M	DISPL. z-DIR M	MOMENT z-DIR KN- M	MOMENT y-DIR KN- M	SHEAR y-DIR KN	SHEAR z-DIR KN	SOIL REACT y-DIR KN/ M	SOIL REACT z-DIR KN/ M	TOTAL STRESS KN/ M**2	FLEX. RIG. z-DIR KN- M**2	FLEX. RIG. y-DIR KN- M**2
*****	*****	*****	*****	*****	*****	*****	*****	*****	*****	*****	*****
1	-2.5310E-05	-5.2820E-04	-987.59	-159.35	-149.28	-156.15	-91.698	-35.999	3501.8	7.8279E+06	7.8279E+06
x (M)	9.1800	0.0000	0.0000	5.4000	7.8300	0.0000	10.260	4.0500	27.000	0.0000	0.0000
2	-1.9178E-05	-5.1990E-04	-763.61	-132.97	-121.06	-116.07	-58.344	-25.576	2323.3	7.8279E+06	7.8279E+06
x (M)	9.9900	0.0000	0.0000	5.6700	8.6400	0.0000	10.260	4.3200	27.000	0.0000	0.0000
3	-1.9386E-05	-5.1160E-04	-773.04	-131.79	-122.06	-115.12	-59.840	-25.437	1144.7	7.8279E+06	7.8279E+06
x (M)	9.9900	0.0000	0.0000	5.6700	8.6400	0.0000	10.260	4.3200	27.000	0.0000	0.0000
4	-2.4163E-05	-5.2820E-04	-936.27	-154.74	-142.89	-148.66	-85.966	-33.998	3690.1	7.8279E+06	7.8279E+06
x (M)	9.4500	0.0000	0.0000	5.4000	8.1000	0.0000	10.260	4.0500	27.000	0.0000	0.0000
5	-1.7297E-05	-5.1990E-04	-681.90	-125.05	-111.51	-104.31	-47.544	-22.591	2581.5	7.8279E+06	7.8279E+06
x (M)	10.260	0.0000	0.0000	5.9400	8.9100	0.0000	10.530	4.3200	27.000	0.0000	0.0000
6	-1.7400E-05	-5.1160E-04	-687.51	-123.55	-112.09	-102.98	-48.313	-22.354	1403.0	7.8279E+06	7.8279E+06
x (M)	10.260	0.0000	0.0000	5.9400	8.9100	0.0000	10.530	4.3200	27.000	0.0000	0.0000
7	-2.4181E-05	-5.2820E-04	-930.70	-155.06	-142.52	-149.11	-85.837	-34.128	3862.2	7.8279E+06	7.8279E+06
x (M)	9.4500	0.0000	0.0000	5.4000	8.1000	0.0000	10.260	4.0500	27.000	0.0000	0.0000
8	-1.7380E-05	-5.1990E-04	-678.47	-125.45	-111.42	-104.80	-47.896	-22.723	2839.7	7.8279E+06	7.8279E+06
x (M)	10.260	0.0000	0.0000	5.9400	8.9100	0.0000	10.530	4.3200	27.000	0.0000	0.0000
9	-1.7477E-05	-5.1160E-04	-684.42	-123.98	-112.00	-103.51	-48.694	-22.500	1661.2	7.8279E+06	7.8279E+06
x (M)	10.260	0.0000	0.0000	5.9400	8.9100	0.0000	10.530	4.3200	27.000	0.0000	0.0000
10	-2.5672E-05	-5.2820E-04	-977.94	-161.14	-149.41	-158.90	-92.010	-36.772	4034.3	7.8279E+06	7.8279E+06
x (M)	9.1800	0.0000	0.0000	5.4000	7.8300	0.0000	10.260	3.7800	27.000	0.0000	0.0000
11	-1.9757E-05	-5.1990E-04	-765.95	-135.78	-122.21	-119.85	-61.780	-26.572	3098.0	7.8279E+06	7.8279E+06
x (M)	9.9900	0.0000	0.0000	5.6700	8.6400	0.0000	10.260	4.3200	27.000	0.0000	0.0000
12	-1.9901E-05	-5.1160E-04	-774.99	-134.49	-123.16	-118.81	-63.177	-26.411	1919.4	7.8279E+06	7.8279E+06
x (M)	9.9900	0.0000	0.0000	5.6700	8.3700	0.0000	10.260	4.3200	27.000	0.0000	0.0000
Min.	-2.5672E-05	-5.2820E-04	-987.59	-161.14	-149.41	-158.90	-92.010	-36.772	1144.7	7.8279E+06	7.8279E+06
Pile N.	10	1	1	10	10	10	10	10	3	1	1

* MAXIMUM VALUES AND LOCATIONS *

PILE	DISPL. y-DIR M	DISPL. z-DIR M	MOMENT z-DIR KN- M	MOMENT y-DIR KN- M	SHEAR y-DIR KN	SHEAR z-DIR KN	SOIL REACT y-DIR KN/ M	SOIL REACT z-DIR KN/ M	TOTAL STRESS KN/ M**2	FLEX. RIG. z-DIR KN- M**2	FLEX. RIG. y-DIR KN- M**2
*****	*****	*****	*****	*****	*****	*****	*****	*****	*****	*****	*****
1	1.9697E-03	6.6491E-06	589.12	316.62	535.99	40.919	126.21	25.121	6631.8	7.8279E+06	7.8279E+06
x (M)	0.0000	9.4500	5.1300	0.0000	0.0000	8.1000	3.7800	10.260	0.0000	0.0000	0.0000
2	1.9697E-03	4.8857E-06	501.62	245.23	403.19	32.709	90.653	15.350	4743.8	7.8279E+06	7.8279E+06
x (M)	0.0000	10.260	5.6700	0.0000	0.0000	8.9100	4.3200	10.530	0.0000	0.0000	0.0000
3	1.9697E-03	4.8624E-06	505.11	240.53	409.30	32.413	92.140	15.412	3588.1	7.8279E+06	7.8279E+06
x (M)	0.0000	9.9900	5.6700	0.0000	0.0000	8.6400	4.0500	10.530	0.0000	0.0000	0.0000
4	1.9614E-03	6.3318E-06	570.20	304.36	506.22	39.459	118.26	23.542	6661.4	7.8279E+06	7.8279E+06
x (M)	0.0000	9.4500	5.4000	0.0000	0.0000	8.1000	3.7800	10.260	0.0000	0.0000	0.0000
5	1.9614E-03	4.4548E-06	469.86	224.15	358.47	30.325	79.540	12.484	4747.8	7.8279E+06	7.8279E+06
x (M)	0.0000	10.530	5.6700	0.0000	0.0000	9.1800	4.3200	10.800	0.0000	0.0000	0.0000
6	1.9614E-03	4.4076E-06	472.02	218.85	362.28	29.915	80.405	12.432	3580.5	7.8279E+06	7.8279E+06
x (M)	0.0000	10.530	5.6700	0.0000	0.0000	9.1800	4.3200	10.800	0.0000	0.0000	0.0000
7	1.9531E-03	6.3650E-06	568.78	305.16	504.60	39.555	118.05	23.623	6818.2	7.8279E+06	7.8279E+06
x (M)	0.0000	9.4500	5.4000	0.0000	0.0000	8.1000	3.7800	10.260	0.0000	0.0000	0.0000
8	1.9531E-03	4.4830E-06	469.37	225.13	357.83	30.437	79.529	12.584	4997.2	7.8279E+06	7.8279E+06
x (M)	0.0000	10.530	5.6700	0.0000	0.0000	9.1800	4.3200	10.800	0.0000	0.0000	0.0000
9	1.9531E-03	4.4334E-06	471.65	219.91	361.84	30.027	80.449	12.543	3830.8	7.8279E+06	7.8279E+06
x (M)	0.0000	10.530	5.6700	0.0000	0.0000	8.9100	4.3200	10.530	0.0000	0.0000	0.0000
10	1.9448E-03	6.7866E-06	588.26	321.31	535.61	41.481	126.81	25.611	7140.9	7.8279E+06	7.8279E+06
x (M)	0.0000	9.4500	5.1300	0.0000	0.0000	7.8300	3.7800	10.260	0.0000	0.0000	0.0000
11	1.9448E-03	5.1038E-06	504.80	252.17	408.77	33.575	92.652	16.312	5531.7	7.8279E+06	7.8279E+06
x (M)	0.0000	9.9900	5.4000	0.0000	0.0000	8.6400	4.0500	10.260	0.0000	0.0000	0.0000
12	1.9448E-03	5.0873E-06	508.37	247.27	414.72	33.225	94.113	16.464	4374.6	7.8279E+06	7.8279E+06
x (M)	0.0000	9.9900	5.4000	0.0000	0.0000	8.6400	4.0500	10.260	0.0000	0.0000	0.0000
Max.	1.9697E-03	6.7866E-06	589.12	321.31	535.99	41.481	126.81	25.611	7140.9	7.8279E+06	7.8279E+06
Pile N.	1	10	1	10	1	10	10	10	10	1	1

***** SUMMARY FOR LOAD CASES AND COMBINATIONS *****

***** LOAD CASES RESULTS *****

LOAD CASE : 1

* TABLE L * COMPUTATION ON PILE CAP

* EQUIVALENT CONCENTRATED LOAD AT ORIGIN *

LOAD X, KN	LOAD Y, KN	LOAD Z, KN	MOM X, KN- M	MOM Y, KN- M	MOM Z, KN- M
32966.0	18789.1	-4279.00	-713.000	-45399.2	-1.74685E+05

* DISPLACEMENT OF GROUPED PILE FOUNDATION AT ORIGIN *

DISP X, M	DISP Y, M	DISP Z, M	ROT X,RAD	ROT Y,RAD	ROT Z,RAD
1.68753E-03	0.0122511	-2.57097E-03	1.17591E-05	-1.23722E-04	-8.25963E-04

* PILE TOP DISPLACEMENTS, GLOBAL *

DISP. X, M	DISP. Y, M	DISP. Z, M	ROT. X,RAD	ROT. Y,RAD	ROT. Z,RAD
------------	------------	------------	------------	------------	------------

APPALTATORE:

Consorzio

Soci



ITINERARIO NAPOLI – BARI

PROGETTAZIONE:

Mandataria

Mandanti



RADDOPPIO TRATTA APICE – ORSARA
I LOTTO FUNZIONALE APICE – HIRPINIA

PROGETTO ESECUTIVO

RELAZIONE DI CALCOLO FONDAZIONI SPALLA A

COMMESSA LOTTO CODIFICA DOCUMENTO REV. FOGLIO
IF1N 01 E ZZ RG MD0000 001 B 100 di 109

	*****	*****	*****	*****	*****	*****
MINIMUM	-2.8644E-03	0.012172	-2.6239E-03	1.1759E-05	-1.2372E-04	-8.2596E-04
Pile N.	3	1	3	1	1	1
MAXIMUM	6.2395E-03	0.012330	-2.5180E-03	1.1759E-05	-1.2372E-04	-8.2596E-04
Pile N.	10	10	1	1	1	1

* PILE TOP REACTIONS, GLOBAL *

	FOR. X, KN	FOR. Y, KN	FOR. Z, KN	MOM X, KN- M	MOM Y, KN- M	MOM Z, KN- M
MINIMUM	-5416.5	1313.3	-428.66	3.1223	967.47	3864.3
Pile N.	3	5	10	1	5	5
MAXIMUM	9425.9	1953.1	-302.14	3.1223	1241.4	5317.3
Pile N.	10	10	8	1	10	10

* PILE TOP DISPLACEMENTS, LOCAL *

	DISP. x, M	DISP. y, M	DISP. z, M	ROT. x, RAD	ROT. y, RAD	ROT. z, RAD
MINIMUM	-2.8644E-03	0.012172	-2.6239E-03	1.1759E-05	-1.2372E-04	-8.2596E-04
Pile N.	3	1	3	1	1	1
MAXIMUM	6.2395E-03	0.012330	-2.5180E-03	1.1759E-05	-1.2372E-04	-8.2596E-04
Pile N.	10	10	1	1	1	1

* PILE TOP REACTIONS, LOCAL *

	AXIAL, KN	LAT. y, KN	LAT. z, KN	MOM x, KN- M	MOM y, KN- M	MOM z, KN- M
MINIMUM	-5416.5	1313.3	-428.66	3.1223	967.47	3864.3
Pile N.	3	5	10	1	5	5
MAXIMUM	9425.9	1953.1	-302.14	3.1223	1241.4	5317.3
Pile N.	10	10	8	1	10	10

* EFFECTS FOR LATERALLY LOADED PILE *

PILE	DISPL. y-DIR M	DISPL. z-DIR M	MOMENT z-DIR KN- M	MOMENT y-DIR KN- M	SHEAR y-DIR KN	SHEAR z-DIR KN	SOIL REACT y-DIR KN/ M	SOIL REACT z-DIR KN/ M	TOTAL STRESS KN/ M**2
Min.	-9.0035E-05	-2.6239E-03	-5317.3	-484.19	-577.22	-428.86	-184.86	-85.904	969.51
Pile N.	8	3	10	10	10	10	10	10	2
Max.	0.012330	2.0388E-05	2341.7	1241.4	1954.0	124.48	399.99	39.803	2.1813E+04
Pile N.	10	9	10	10	10	10	10	10	10

LOAD CASE : 2

* TABLE L * COMPUTATION ON PILE CAP

* EQUIVALENT CONCENTRATED LOAD AT ORIGIN *

LOAD X, KN	LOAD Y, KN	LOAD Z, KN	MOM X, KN- M	MOM Y, KN- M	MOM Z, KN- M
40273.0	-17902.5	4217.40	656.000	46241.8	1.58806E+05

* DISPLACEMENT OF GROUPED PILE FOUNDATION AT ORIGIN *

DISP X, M	DISP Y, M	DISP Z, M	ROT X, RAD	ROT Y, RAD	ROT Z, RAD
2.02718E-03	-0.0112945	2.48443E-03	3.16456E-05	1.25887E-04	7.68267E-04

* PILE TOP DISPLACEMENTS, GLOBAL *

	DISP. X, M	DISP. Y, M	DISP. Z, M	ROT. X, RAD	ROT. Y, RAD	ROT. Z, RAD
MINIMUM	-2.2798E-03	-0.011508	2.3420E-03	3.1646E-05	1.2589E-04	7.6827E-04
Pile N.	10	1	3	1	1	1
MAXIMUM	6.3341E-03	-0.011081	2.6268E-03	3.1646E-05	1.2589E-04	7.6827E-04
Pile N.	3	10	1	1	1	1

* PILE TOP REACTIONS, GLOBAL *

	FOR. X, KN	FOR. Y, KN	FOR. Z, KN	MOM X, KN- M	MOM Y, KN- M	MOM Z, KN- M
MINIMUM	-4325.3	-1882.6	298.06	8.4026	-1147.4	-5082.2
Pile N.	10	3	5	1	12	3
MAXIMUM	9464.4	-1245.9	407.84	8.4026	-935.68	-3614.0
Pile N.	3	8	12	1	5	8

* PILE TOP DISPLACEMENTS, LOCAL *

	DISP. x, M	DISP. y, M	DISP. z, M	ROT. x, RAD	ROT. y, RAD	ROT. z, RAD
MINIMUM	-2.2798E-03	-0.011508	2.3420E-03	3.1646E-05	1.2589E-04	7.6827E-04
Pile N.	10	1	3	1	1	1
MAXIMUM	6.3341E-03	-0.011081	2.6268E-03	3.1646E-05	1.2589E-04	7.6827E-04
Pile N.	3	10	1	1	1	1

* PILE TOP REACTIONS, LOCAL *

	AXIAL, KN	LAT. y, KN	LAT. z, KN	MOM x, KN- M	MOM y, KN- M	MOM z, KN- M
MINIMUM	-4325.3	-1882.6	298.06	8.4026	-1147.4	-5082.2
Pile N.	10	3	5	1	12	3
MAXIMUM	9464.4	-1245.9	407.84	8.4026	-935.68	-3614.0
Pile N.	3	8	12	1	5	8

* EFFECTS FOR LATERALLY LOADED PILE *

PILE	DISPL.	DISPL.	MOMENT	MOMENT	SHEAR	SHEAR	SOIL REACT	SOIL REACT	TOTAL
------	--------	--------	--------	--------	-------	-------	------------	------------	-------

APPALTATORE:

Consorzio

Soci



ITINERARIO NAPOLI – BARI

PROGETTAZIONE:

Mandataria

Mandanti



RADDOPPIO TRATTA APICE – ORSARA
I LOTTO FUNZIONALE APICE – HIRPINIA

PROGETTO ESECUTIVO

RELAZIONE DI CALCOLO FONDAZIONI SPALLA A

COMMESSA IF1N	LOTTO 01 E ZZ	CODIFICA RG	DOCUMENTO MD0000 001	REV. B	FOGLIO 101 di 109
------------------	------------------	----------------	-------------------------	-----------	-------------------------

	y-DIR M	z-DIR M	z-DIR KN- M	y-DIR KN- M	y-DIR KN	z-DIR KN	y-DIR KN/ M	z-DIR KN/ M	STRESS KN/ M**2
*****	*****	*****	*****	*****	*****	*****	*****	*****	*****
Min.	-0.011508	-1.9896E-05	-2222.5	-1147.4	-1883.5	-115.40	-384.91	-37.749	651.00
Pile N.	1	4	3	12	3	12	3	12	1
Max.	8.1270E-05	2.6268E-03	5082.2	457.91	546.36	408.00	176.86	81.891	2.1076E+04
Pile N.	5	1	3	12	3	12	3	12	3

LOAD CASE : 3

* TABLE L * COMPUTATION ON PILE CAP

* EQUIVALENT CONCENTRATED LOAD AT ORIGIN *

LOAD X, KN	LOAD Y, KN	LOAD Z, KN	MOM X, KN- M	MOM Y, KN- M	MOM Z, KN- M
33688.0	5952.10	-14214.2	-2207.00	-1.52276E+05	-57250.1

* DISPLACEMENT OF GROUPED PILE FOUNDATION AT ORIGIN *

DISP X, M	DISP Y, M	DISP Z, M	ROT X,RAD	ROT Y,RAD	ROT Z,RAD
1.51871E-03	3.41860E-03	-7.28611E-03	-4.36765E-05	-3.49585E-04	-2.52366E-04

* PILE TOP DISPLACEMENTS, GLOBAL *

	DISP. X, M	DISP. Y, M	DISP. Z, M	ROT. X,RAD	ROT. Y,RAD	ROT. Z,RAD
*****	*****	*****	*****	*****	*****	*****
MINIMUM	-1.9766E-03	3.1238E-03	-7.4827E-03	-4.3677E-05	-3.4959E-04	-2.5237E-04
Pile N.	3	10	1	1	1	1
MAXIMUM	5.0141E-03	3.7134E-03	-7.0896E-03	-4.3677E-05	-3.4959E-04	-2.5237E-04
Pile N.	10	1	3	1	1	1

* PILE TOP REACTIONS, GLOBAL *

	FOR. X, KN	FOR. Y, KN	FOR. Z, KN	MOM X, KN- M	MOM Y, KN- M	MOM Z, KN- M
*****	*****	*****	*****	*****	*****	*****
MINIMUM	-3759.6	409.35	-1525.8	-11.597	2976.0	1099.4
Pile N.	3	8	10	1	5	8
MAXIMUM	8499.5	562.78	-975.17	-11.597	4194.8	1510.5
Pile N.	10	1	5	1	10	1

* PILE TOP DISPLACEMENTS, LOCAL *

	DISP. x, M	DISP. y, M	DISP. z, M	ROT. x,RAD	ROT. y,RAD	ROT. z,RAD
*****	*****	*****	*****	*****	*****	*****
MINIMUM	-1.9766E-03	3.1238E-03	-7.4827E-03	-4.3677E-05	-3.4959E-04	-2.5237E-04
Pile N.	3	10	1	1	1	1
MAXIMUM	5.0141E-03	3.7134E-03	-7.0896E-03	-4.3677E-05	-3.4959E-04	-2.5237E-04
Pile N.	10	1	3	1	1	1

* PILE TOP REACTIONS, LOCAL *

	AXIAL, KN	LAT. y, KN	LAT. z, KN	MOM x, KN- M	MOM y, KN- M	MOM z, KN- M
*****	*****	*****	*****	*****	*****	*****
MINIMUM	-3759.6	409.35	-1525.8	-11.597	2976.0	1099.4
Pile N.	3	8	10	1	5	8
MAXIMUM	8499.5	562.78	-975.17	-11.597	4194.8	1510.5
Pile N.	10	1	5	1	10	1

* EFFECTS FOR Laterally LOADED PILE *

PILE	DISPL. y-DIR M	DISPL. z-DIR M	MOMENT z-DIR KN- M	MOMENT y-DIR KN- M	SHEAR y-DIR KN	SHEAR z-DIR KN	SOIL REACT y-DIR KN/ M	SOIL REACT z-DIR KN/ M	TOTAL STRESS KN/ M**2
*****	*****	*****	*****	*****	*****	*****	*****	*****	*****
Min.	-2.3542E-05	-7.4827E-03	-1510.5	-1573.5	-162.53	-1526.4	-51.965	-305.26	340.24
Pile N.	2	1	1	10	1	10	10	10	1
Max.	3.7134E-03	5.1845E-05	665.67	4194.8	562.80	391.47	115.68	134.37	1.8124E+04
Pile N.	1	5	1	10	1	10	10	10	10

LOAD CASE : 4

* TABLE L * COMPUTATION ON PILE CAP

* EQUIVALENT CONCENTRATED LOAD AT ORIGIN *

LOAD X, KN	LOAD Y, KN	LOAD Z, KN	MOM X, KN- M	MOM Y, KN- M	MOM Z, KN- M
40046.0	-5241.50	14056.9	2188.00	1.54136E+05	43619.9

* DISPLACEMENT OF GROUPED PILE FOUNDATION AT ORIGIN *

DISP X, M	DISP Y, M	DISP Z, M	ROT X,RAD	ROT Y,RAD	ROT Z,RAD
1.81227E-03	-2.89831E-03	7.15343E-03	8.08327E-06	3.55136E-04	2.04361E-04

* PILE TOP DISPLACEMENTS, GLOBAL *

	DISP. X, M	DISP. Y, M	DISP. Z, M	ROT. X,RAD	ROT. Y,RAD	ROT. Z,RAD
*****	*****	*****	*****	*****	*****	*****
MINIMUM	-1.5045E-03	-2.9529E-03	7.1171E-03	8.0833E-06	3.5514E-04	2.0436E-04
Pile N.	10	1	3	1	1	1
MAXIMUM	5.1291E-03	-2.8437E-03	7.1898E-03	8.0833E-06	3.5514E-04	2.0436E-04
Pile N.	3	10	1	1	1	1

* PILE TOP REACTIONS, GLOBAL *

	FOR. X, KN	FOR. Y, KN	FOR. Z, KN	MOM X, KN- M	MOM Y, KN- M	MOM Z, KN- M
*****	*****	*****	*****	*****	*****	*****
MINIMUM	-2878.5	-565.88	966.58	2.1463	-3966.0	-1438.1
Pile N.	10	3	8	1	3	3

APPALTATORE:

Consorzio

Soci



ITINERARIO NAPOLI – BARI

PROGETTAZIONE:

Mandatario

Mandanti



RADDOPPIO TRATTA APICE – ORSARA
I LOTTO FUNZIONALE APICE – HIRPINIA

PROGETTO ESECUTIVO

RELAZIONE DI CALCOLO FONDAZIONI SPALLA A

COMMESSA IF1N	LOTTO 01 E ZZ	CODIFICA RG	DOCUMENTO MD0000 001	REV. B	FOGLIO 102 di 109
------------------	------------------	----------------	-------------------------	-----------	-------------------------

MAXIMUM	8644.9	-354.37	1465.4	2.1463	-2917.4	-978.03
Pile N.	3	8	3	1	8	8

* PILE TOP DISPLACEMENTS, LOCAL *

	DISP. x, M	DISP. y, M	DISP. z, M	ROT. x,RAD	ROT. y,RAD	ROT. z,RAD
MINIMUM	-1.5045E-03	-2.9529E-03	7.1171E-03	8.0833E-06	3.5514E-04	2.0436E-04
Pile N.	10	1	3	1	1	1
MAXIMUM	5.1291E-03	-2.8437E-03	7.1898E-03	8.0833E-06	3.5514E-04	2.0436E-04
Pile N.	3	10	1	1	1	1

* PILE TOP REACTIONS, LOCAL *

	AXIAL, KN	LAT. y, KN	LAT. z, KN	MOM x, KN- M	MOM y, KN- M	MOM z, KN- M
MINIMUM	-2878.5	-565.88	966.58	2.1463	-3966.0	-1438.1
Pile N.	10	3	8	1	3	3
MAXIMUM	8644.9	-354.37	1465.4	2.1463	-2917.4	-978.03
Pile N.	3	8	3	1	8	8

* EFFECTS FOR LATERALLY LOADED PILE *

PILE	DISPL. y-DIR	DISPL. z-DIR	MOMENT z-DIR	MOMENT y-DIR	SHEAR y-DIR	SHEAR z-DIR	SOIL REACT y-DIR	SOIL REACT z-DIR	TOTAL STRESS
	M	M	KN- M	KN- M	KN	KN	KN/ M	KN/ M	KN/ M**2
Min.	-2.9529E-03	-5.0172E-05	-620.86	-3966.0	-566.10	-373.33	-115.78	-129.17	108.06
Pile N.	1	8	3	3	3	3	3	3	7
Max.	1.8832E-05	7.1898E-03	1438.1	1512.8	150.09	1466.0	51.430	294.57	1.7624E+04
Pile N.	8	1	3	3	3	3	3	3	3

LOAD CASE : 5

* TABLE L * COMPUTATION ON PILE CAP

* EQUIVALENT CONCENTRATED LOAD AT ORIGIN *

LOAD X, KN	LOAD Y, KN	LOAD Z, KN	MOM X, KN- M	MOM Y, KN- M	MOM Z, KN- M
50606.0	-5831.10	4217.40	656.000	46544.3	48629.3

* DISPLACEMENT OF GROUPED PILE FOUNDATION AT ORIGIN *

DISP X, M	DISP Y, M	DISP Z, M	ROT X,RAD	ROT Y,RAD	ROT Z,RAD
2.1898E-03	-2.2085E-03	1.46899E-03	8.31463E-06	1.02498E-04	2.05767E-04

* PILE TOP DISPLACEMENTS, GLOBAL *

	DISP. X, M	DISP. Y, M	DISP. Z, M	ROT. X,RAD	ROT. Y,RAD	ROT. Z,RAD
MINIMUM	5.7207E-04	-2.2647E-03	1.4316E-03	8.3146E-06	1.0250E-04	2.0577E-04
Pile N.	10	1	3	1	1	1
MAXIMUM	3.8077E-03	-2.1524E-03	1.5064E-03	8.3146E-06	1.0250E-04	2.0577E-04
Pile N.	3	10	1	1	1	1

* PILE TOP REACTIONS, GLOBAL *

	FOR. X, KN	FOR. Y, KN	FOR. Z, KN	MOM X, KN- M	MOM Y, KN- M	MOM Z, KN- M
MINIMUM	1167.3	-623.11	294.71	2.2077	-959.78	-1335.7
Pile N.	10	3	8	1	3	3
MAXIMUM	6973.4	-398.85	420.64	2.2077	-741.39	-908.22
Pile N.	3	8	3	1	8	8

* PILE TOP DISPLACEMENTS, LOCAL *

	DISP. x, M	DISP. y, M	DISP. z, M	ROT. x,RAD	ROT. y,RAD	ROT. z,RAD
MINIMUM	5.7207E-04	-2.2647E-03	1.4316E-03	8.3146E-06	1.0250E-04	2.0577E-04
Pile N.	10	1	3	1	1	1
MAXIMUM	3.8077E-03	-2.1524E-03	1.5064E-03	8.3146E-06	1.0250E-04	2.0577E-04
Pile N.	3	10	1	1	1	1

* PILE TOP REACTIONS, LOCAL *

	AXIAL, KN	LAT. y, KN	LAT. z, KN	MOM x, KN- M	MOM y, KN- M	MOM z, KN- M
MINIMUM	1167.3	-623.11	294.71	2.2077	-959.78	-1335.7
Pile N.	10	3	8	1	3	3
MAXIMUM	6973.4	-398.85	420.64	2.2077	-741.39	-908.22
Pile N.	3	8	3	1	8	8

* EFFECTS FOR LATERALLY LOADED PILE *

PILE	DISPL. y-DIR	DISPL. z-DIR	MOMENT z-DIR	MOMENT y-DIR	SHEAR y-DIR	SHEAR z-DIR	SOIL REACT y-DIR	SOIL REACT z-DIR	TOTAL STRESS
	M	M	KN- M	KN- M	KN	KN	KN/ M	KN/ M	KN/ M**2
Min.	-2.2647E-03	-1.4558E-05	-638.61	-959.78	-623.27	-106.74	-138.39	-57.367	660.58
Pile N.	1	3	3	3	3	3	3	3	10
Max.	2.3441E-05	1.5064E-03	1335.7	407.89	164.75	420.75	89.883	92.170	8910.3
Pile N.	3	1	3	3	3	3	3	3	3

LOAD CASE : 6

* TABLE L * COMPUTATION ON PILE CAP

APPALTATORE: Consorzio Soci   		ITINERARIO NAPOLI – BARI RADDOPPIO TRATTA APICE – ORSARA I LOTTO FUNZIONALE APICE – HIRPINIA					
PROGETTAZIONE: Mandataria Mandanti   							
PROGETTO ESECUTIVO RELAZIONE DI CALCOLO FONDAZIONI SPALLA A		COMMESSA IF1N	LOTTO 01 E ZZ	CODIFICA RG	DOCUMENTO MD0000 001	REV. B	FOGLIO 103 di 109

* EQUIVALENT CONCENTRATED LOAD AT ORIGIN *

LOAD X, KN	LOAD Y, KN	LOAD Z, KN	MOM X, KN- M	MOM Y, KN- M	MOM Z, KN- M
20964.0	6066.50	-4217.40	-656.000	-46234.1	-56934.3

* DISPLACEMENT OF GROUPED PILE FOUNDATION AT ORIGIN *

DISP X, M	DISP Y, M	DISP Z, M	ROT X,RAD	ROT Y,RAD	ROT Z,RAD
8.88827E-04	2.34504E-03	-1.46040E-03	-1.62165E-06	-9.57593E-05	-2.23042E-04

* PILE TOP DISPLACEMENTS, GLOBAL *

	DISP. X, M	DISP. Y, M	DISP. Z, M	ROT. X,RAD	ROT. Y,RAD	ROT. Z,RAD
MINIMUM	-7.6124E-04	2.3341E-03	-1.4677E-03	-1.6216E-06	-9.5759E-05	-2.2304E-04
Pile N.	3	10	1	1	1	1
MAXIMUM	2.5389E-03	2.3560E-03	-1.4531E-03	-1.6216E-06	-9.5759E-05	-2.2304E-04
Pile N.	10	1	3	1	1	1

* PILE TOP REACTIONS, GLOBAL *

	FOR. X, KN	FOR. Y, KN	FOR. Z, KN	MOM X, KN- M	MOM Y, KN- M	MOM Z, KN- M
MINIMUM	-1491.3	420.18	-436.96	-0.4306	751.55	952.86
Pile N.	3	5	10	1	5	5
MAXIMUM	4914.9	626.60	-293.79	-0.4306	1016.7	1321.3
Pile N.	10	10	5	1	10	10

* PILE TOP DISPLACEMENTS, LOCAL *

	DISP. x, M	DISP. y, M	DISP. z, M	ROT. x,RAD	ROT. y,RAD	ROT. z,RAD
MINIMUM	-7.6124E-04	2.3341E-03	-1.4677E-03	-1.6216E-06	-9.5759E-05	-2.2304E-04
Pile N.	3	10	1	1	1	1
MAXIMUM	2.5389E-03	2.3560E-03	-1.4531E-03	-1.6216E-06	-9.5759E-05	-2.2304E-04
Pile N.	10	1	3	1	1	1

* PILE TOP REACTIONS, LOCAL *

	AXIAL, KN	LAT. y, KN	LAT. z, KN	MOM x, KN- M	MOM y, KN- M	MOM z, KN- M
MINIMUM	-1491.3	420.18	-436.96	-0.4306	751.55	952.86
Pile N.	3	5	10	1	5	5
MAXIMUM	4914.9	626.60	-293.79	-0.4306	1016.7	1321.3
Pile N.	10	10	5	1	10	10

* EFFECTS FOR LATERALLY LOADED PILE *

PILE	DISPL. y-DIR M	DISPL. z-DIR M	MOMENT z-DIR KN- M	MOMENT y-DIR KN- M	SHEAR y-DIR KN	SHEAR z-DIR KN	SOIL REACT y-DIR KN/ M	SOIL REACT z-DIR KN/ M	TOTAL STRESS KN/ M**2
Min.	-2.3993E-05	-1.4677E-03	-1321.3	-418.36	-167.70	-437.04	-90.841	-95.231	116.16
Pile N.	10	1	10	10	10	10	10	10	9
Max.	2.3560E-03	1.4666E-05	653.16	1016.7	626.71	109.95	139.38	57.920	7813.70
Pile N.	1	10	10	10	10	10	10	10	10

LOAD CASE : 7

* TABLE L * COMPUTATION ON PILE CAP

* EQUIVALENT CONCENTRATED LOAD AT ORIGIN *

LOAD X, KN	LOAD Y, KN	LOAD Z, KN	MOM X, KN- M	MOM Y, KN- M	MOM Z, KN- M
29966.0	5712.30	-14056.9	-2188.00	-1.54123E+05	-54337.2

* DISPLACEMENT OF GROUPED PILE FOUNDATION AT ORIGIN *

DISP X, M	DISP Y, M	DISP Z, M	ROT X,RAD	ROT Y,RAD	ROT Z,RAD
1.33964E-03	3.24031E-03	-7.15355E-03	-4.30247E-05	-3.47409E-04	-2.37099E-04

* PILE TOP DISPLACEMENTS, GLOBAL *

	DISP. X, M	DISP. Y, M	DISP. Z, M	ROT. X,RAD	ROT. Y,RAD	ROT. Z,RAD
MINIMUM	-2.0723E-03	2.9499E-03	-7.3472E-03	-4.3025E-05	-3.4741E-04	-2.3710E-04
Pile N.	3	10	1	1	1	1
MAXIMUM	4.7516E-03	3.5307E-03	-6.9599E-03	-4.3025E-05	-3.4741E-04	-2.3710E-04
Pile N.	10	1	3	1	1	1

* PILE TOP REACTIONS, GLOBAL *

	FOR. X, KN	FOR. Y, KN	FOR. Z, KN	MOM X, KN- M	MOM Y, KN- M	MOM Z, KN- M
MINIMUM	-3938.2	392.69	-1509.8	-11.424	2926.8	1054.7
Pile N.	3	8	10	1	5	8
MAXIMUM	8167.4	540.63	-964.16	-11.424	4130.6	1452.4
Pile N.	10	1	5	1	10	1

* PILE TOP DISPLACEMENTS, LOCAL *

	DISP. x, M	DISP. y, M	DISP. z, M	ROT. x,RAD	ROT. y,RAD	ROT. z,RAD
MINIMUM	-2.0723E-03	2.9499E-03	-7.3472E-03	-4.3025E-05	-3.4741E-04	-2.3710E-04
Pile N.	3	10	1	1	1	1
MAXIMUM	4.7516E-03	3.5307E-03	-6.9599E-03	-4.3025E-05	-3.4741E-04	-2.3710E-04
Pile N.	10	1	3	1	1	1

APPALTATORE: Consorzio Soci   	ITINERARIO NAPOLI – BARI RADDOPPIO TRATTA APICE – ORSARA I LOTTO FUNZIONALE APICE – HIRPINIA
PROGETTAZIONE: Mandataria Mandanti   	
PROGETTO ESECUTIVO RELAZIONE DI CALCOLO FONDAZIONI SPALLA A	COMMESSA IF1N LOTTO 01 E ZZ CODIFICA RG DOCUMENTO MD0000 001 REV. B FOGLIO 104 di 109

* PILE TOP REACTIONS, LOCAL *

	AXIAL, KN	LAT. y, KN	LAT. z, KN	MOM x, KN- M	MOM y, KN- M	MOM z, KN- M
MINIMUM	-3938.2	392.69	-1509.8	-11.424	2926.8	1054.7
Pile N.	3	8	10	1	5	8
MAXIMUM	8167.4	540.63	-964.16	-11.424	4130.6	1452.4
Pile N.	10	1	5	1	10	1

* EFFECTS FOR LATERALLY LOADED PILE *

PILE	DISPL. y-DIR M	DISPL. z-DIR M	MOMENT KN- M	MOMENT y-DIR KN- M	SHEAR y-DIR KN	SHEAR z-DIR KN	SOIL REACT y-DIR KN/ M	SOIL REACT z-DIR KN/ M	TOTAL STRESS KN/ M**2
Min.	-2.2316E-05	-7.3472E-03	-1452.4	-1553.1	-155.43	-1510.4	-49.615	-302.40	71.100
Pile N.	2	1	1	10	1	10	10	10	1
Max.	3.5307E-03	5.0535E-05	635.17	4130.6	540.64	385.01	110.52	132.85	1.7695E+04
Pile N.	1	5	1	10	1	10	10	10	10

LOAD CASE : 8

* TABLE L * COMPUTATION ON PILE CAP

* EQUIVALENT CONCENTRATED LOAD AT ORIGIN *

LOAD X, KN	LOAD Y, KN	LOAD Z, KN	MOM X, KN- M	MOM Y, KN- M	MOM Z, KN- M
40768.0	-5150.20	13956.8	2177.00	1.56782E+05	42953.9

* DISPLACEMENT OF GROUPED PILE FOUNDATION AT ORIGIN *

DISP X, M	DISP Y, M	DISP Z, M	ROT X,RAD	ROT Y,RAD	ROT Z,RAD
1.85123E-03	-2.83801E-03	7.09753E-03	8.23212E-06	3.60666E-04	2.01492E-04

* PILE TOP DISPLACEMENTS, GLOBAL *

	DISP. X, M	DISP. Y, M	DISP. Z, M	ROT. X,RAD	ROT. Y,RAD	ROT. Z,RAD
MINIMUM	-1.4900E-03	-2.8936E-03	7.0605E-03	8.2321E-06	3.6067E-04	2.0149E-04
Pile N.	10	1	3	1	1	1
MAXIMUM	5.1924E-03	-2.7825E-03	7.1346E-03	8.2321E-06	3.6067E-04	2.0149E-04
Pile N.	3	10	1	1	1	1

* PILE TOP REACTIONS, GLOBAL *

	FOR. X, KN	FOR. Y, KN	FOR. Z, KN	MOM X, KN- M	MOM Y, KN- M	MOM Z, KN- M
MINIMUM	-2851.4	-556.28	958.61	2.1858	-3917.4	-1409.9
Pile N.	10	3	8	1	3	3
MAXIMUM	8725.1	-347.72	1454.4	2.1858	-2877.4	-956.35
Pile N.	3	8	3	1	8	8

* PILE TOP DISPLACEMENTS, LOCAL *

	DISP. x, M	DISP. y, M	DISP. z, M	ROT. x,RAD	ROT. y,RAD	ROT. z,RAD
MINIMUM	-1.4900E-03	-2.8936E-03	7.0605E-03	8.2321E-06	3.6067E-04	2.0149E-04
Pile N.	10	1	3	1	1	1
MAXIMUM	5.1924E-03	-2.7825E-03	7.1346E-03	8.2321E-06	3.6067E-04	2.0149E-04
Pile N.	3	10	1	1	1	1

* PILE TOP REACTIONS, LOCAL *

	AXIAL, KN	LAT. y, KN	LAT. z, KN	MOM x, KN- M	MOM y, KN- M	MOM z, KN- M
MINIMUM	-2851.4	-556.28	958.61	2.1858	-3917.4	-1409.9
Pile N.	10	3	8	1	3	3
MAXIMUM	8725.1	-347.72	1454.4	2.1858	-2877.4	-956.35
Pile N.	3	8	3	1	8	8

* EFFECTS FOR LATERALLY LOADED PILE *

PILE	DISPL. y-DIR M	DISPL. z-DIR M	MOMENT KN- M	MOMENT y-DIR KN- M	SHEAR y-DIR KN	SHEAR z-DIR KN	SOIL REACT y-DIR KN/ M	SOIL REACT z-DIR KN/ M	TOTAL STRESS KN/ M**2
Min.	-2.8936E-03	-4.9478E-05	-610.25	-3917.4	-556.49	-371.36	-113.92	-128.27	153.60
Pile N.	1	8	3	3	3	3	3	3	7
Max.	1.8353E-05	7.1346E-03	1409.9	1504.2	147.58	1455.0	50.621	292.84	1.7503E+04
Pile N.	8	1	3	3	3	3	3	3	3

LOAD CASE : 9

* TABLE L * COMPUTATION ON PILE CAP

* EQUIVALENT CONCENTRATED LOAD AT ORIGIN *

LOAD X, KN	LOAD Y, KN	LOAD Z, KN	MOM X, KN- M	MOM Y, KN- M	MOM Z, KN- M
32966.0	18789.1	-4279.00	-713.000	-45399.2	-1.74685E+05

* DISPLACEMENT OF GROUPED PILE FOUNDATION AT ORIGIN *

DISP X, M	DISP Y, M	DISP Z, M	ROT X,RAD	ROT Y,RAD	ROT Z,RAD
1.68753E-03	0.0122511	-2.57097E-03	1.17591E-05	-1.23722E-04	-8.25963E-04

* PILE TOP DISPLACEMENTS, GLOBAL *

DISP. X, M	DISP. Y, M	DISP. Z, M	ROT. X,RAD	ROT. Y,RAD	ROT. Z,RAD
------------	------------	------------	------------	------------	------------

APPALTATORE:

Consorzio

Soci



ITINERARIO NAPOLI – BARI

PROGETTAZIONE:

Mandatario

Mandanti



RADDOPPIO TRATTA APICE – ORSARA
I LOTTO FUNZIONALE APICE – HIRPINIA

PROGETTO ESECUTIVO

RELAZIONE DI CALCOLO FONDAZIONI SPALLA A

COMMESSA IF1N	LOTTO 01 E ZZ	CODIFICA RG	DOCUMENTO MD0000 001	REV. B	FOGLIO 105 di 109
------------------	------------------	----------------	-------------------------	-----------	-------------------------

MINIMUM	-2.8644E-03	0.012172	-2.6239E-03	1.1759E-05	-1.2372E-04	-8.2596E-04
Pile N.	3	1	3	1	1	1
MAXIMUM	6.2395E-03	0.012330	-2.5180E-03	1.1759E-05	-1.2372E-04	-8.2596E-04
Pile N.	10	10	1	1	1	1

* PILE TOP REACTIONS, GLOBAL *

	FOR. X, KN	FOR. Y, KN	FOR. Z, KN	MOM X, KN- M	MOM Y, KN- M	MOM Z, KN- M
MINIMUM	-5416.5	1313.3	-428.66	3.1223	967.47	3864.3
Pile N.	3	5	10	1	5	5
MAXIMUM	9425.9	1953.1	-302.14	3.1223	1241.4	5317.3
Pile N.	10	10	8	1	10	10

* PILE TOP DISPLACEMENTS, LOCAL *

	DISP. x, M	DISP. y, M	DISP. z, M	ROT. x, RAD	ROT. y, RAD	ROT. z, RAD
MINIMUM	-2.8644E-03	0.012172	-2.6239E-03	1.1759E-05	-1.2372E-04	-8.2596E-04
Pile N.	3	1	3	1	1	1
MAXIMUM	6.2395E-03	0.012330	-2.5180E-03	1.1759E-05	-1.2372E-04	-8.2596E-04
Pile N.	10	10	1	1	1	1

* PILE TOP REACTIONS, LOCAL *

	AXIAL, KN	LAT. y, KN	LAT. z, KN	MOM x, KN- M	MOM y, KN- M	MOM z, KN- M
MINIMUM	-5416.5	1313.3	-428.66	3.1223	967.47	3864.3
Pile N.	3	5	10	1	5	5
MAXIMUM	9425.9	1953.1	-302.14	3.1223	1241.4	5317.3
Pile N.	10	10	8	1	10	10

* EFFECTS FOR LATERALLY LOADED PILE *

PILE	DISPL. y-DIR	DISPL. z-DIR	MOMENT z-DIR	MOMENT y-DIR	SHEAR y-DIR	SHEAR z-DIR	SOIL REACT y-DIR	SOIL REACT z-DIR	TOTAL STRESS
	M	M	KN- M	KN- M	KN	KN	KN/ M	KN/ M	KN/ M**2
Min.	-9.0035E-05	-2.6239E-03	-5317.3	-484.19	-577.22	-428.86	-184.86	-85.904	969.51
Pile N.	8	3	10	10	10	10	10	10	2
Max.	0.012330	2.0388E-05	2341.7	1241.4	1954.0	124.48	399.99	39.803	2.1813E+04
Pile N.	10	9	10	10	10	10	10	10	10

LOAD CASE : 10

* TABLE L * COMPUTATION ON PILE CAP

* EQUIVALENT CONCENTRATED LOAD AT ORIGIN *

LOAD X, KN	LOAD Y, KN	LOAD Z, KN	MOM X, KN- M	MOM Y, KN- M	MOM Z, KN- M
40273.0	-17902.5	4217.40	656.000	46241.8	1.58806E+05

* DISPLACEMENT OF GROUPED PILE FOUNDATION AT ORIGIN *

DISP X, M	DISP Y, M	DISP Z, M	ROT X, RAD	ROT Y, RAD	ROT Z, RAD
2.02718E-03	-0.0112945	2.48443E-03	3.16456E-05	1.25887E-04	7.68267E-04

* PILE TOP DISPLACEMENTS, GLOBAL *

	DISP. X, M	DISP. Y, M	DISP. Z, M	ROT. X, RAD	ROT. Y, RAD	ROT. Z, RAD
MINIMUM	-2.2798E-03	-0.011508	2.3420E-03	3.1646E-05	1.2589E-04	7.6827E-04
Pile N.	10	1	3	1	1	1
MAXIMUM	6.3341E-03	-0.011081	2.6268E-03	3.1646E-05	1.2589E-04	7.6827E-04
Pile N.	3	10	1	1	1	1

* PILE TOP REACTIONS, GLOBAL *

	FOR. X, KN	FOR. Y, KN	FOR. Z, KN	MOM X, KN- M	MOM Y, KN- M	MOM Z, KN- M
MINIMUM	-4325.3	-1882.6	298.06	8.4026	-1147.4	-5082.2
Pile N.	10	3	5	1	12	3
MAXIMUM	9464.4	-1245.9	407.84	8.4026	-935.68	-3614.0
Pile N.	3	8	12	1	5	8

* PILE TOP DISPLACEMENTS, LOCAL *

	DISP. x, M	DISP. y, M	DISP. z, M	ROT. x, RAD	ROT. y, RAD	ROT. z, RAD
MINIMUM	-2.2798E-03	-0.011508	2.3420E-03	3.1646E-05	1.2589E-04	7.6827E-04
Pile N.	10	1	3	1	1	1
MAXIMUM	6.3341E-03	-0.011081	2.6268E-03	3.1646E-05	1.2589E-04	7.6827E-04
Pile N.	3	10	1	1	1	1

* PILE TOP REACTIONS, LOCAL *

	AXIAL, KN	LAT. y, KN	LAT. z, KN	MOM x, KN- M	MOM y, KN- M	MOM z, KN- M
MINIMUM	-4325.3	-1882.6	298.06	8.4026	-1147.4	-5082.2
Pile N.	10	3	5	1	12	3
MAXIMUM	9464.4	-1245.9	407.84	8.4026	-935.68	-3614.0
Pile N.	3	8	12	1	5	8

* EFFECTS FOR LATERALLY LOADED PILE *

PILE	DISPL.	DISPL.	MOMENT	MOMENT	SHEAR	SHEAR	SOIL REACT	SOIL REACT	TOTAL
------	--------	--------	--------	--------	-------	-------	------------	------------	-------

APPALTATORE:

Consorzio

Soci



ITINERARIO NAPOLI – BARI

PROGETTAZIONE:

Mandataria

Mandanti



RADDOPPIO TRATTA APICE – ORSARA
I LOTTO FUNZIONALE APICE – HIRPINIA

PROGETTO ESECUTIVO

RELAZIONE DI CALCOLO FONDAZIONI SPALLA A

COMMESSA IF1N	LOTTO 01 E ZZ	CODIFICA RG	DOCUMENTO MD0000 001	REV. B	FOGLIO 106 di 109
------------------	------------------	----------------	-------------------------	-----------	-------------------------

	y-Dir M	z-Dir M	z-Dir KN- M	y-Dir KN- M	y-Dir KN	z-Dir KN	y-Dir KN/ M	z-Dir KN/ M	STRESS KN/ M**2
Min.	-0.011508	-1.9896E-05	-2222.5	-1147.4	-1883.5	-115.40	-384.91	-37.749	651.00
Pile N.	1	4	3	12	3	12	3	12	1
Max.	8.1270E-05	2.6268E-03	5082.2	457.91	546.36	408.00	176.86	81.891	2.1076E+04
Pile N.	5	1	3	12	3	12	3	12	3

LOAD CASE : 11

* TABLE L * COMPUTATION ON PILE CAP

* EQUIVALENT CONCENTRATED LOAD AT ORIGIN *

LOAD X, KN	LOAD Y, KN	LOAD Z, KN	MOM X, KN- M	MOM Y, KN- M	MOM Z, KN- M
56653.3	5158.00	-1498.00	-716.000	-24450.0	-61609.0

* DISPLACEMENT OF GROUPED PILE FOUNDATION AT ORIGIN *

DISP X, M	DISP Y, M	DISP Z, M	ROT X,RAD	ROT Y,RAD	ROT Z,RAD
2.47314E-03	1.95722E-03	-5.19897E-04	-1.84463E-06	-5.34183E-05	-2.43791E-04

* PILE TOP DISPLACEMENTS, GLOBAL *

	DISP. X, M	DISP. Y, M	DISP. Z, M	ROT. X,RAD	ROT. Y,RAD	ROT. Z,RAD
MINIMUM	1.0155E-03	1.9448E-03	-5.2820E-04	-1.8446E-06	-5.3418E-05	-2.4379E-04
Pile N.	3	10	1	1	1	1
MAXIMUM	3.9308E-03	1.9697E-03	-5.1160E-04	-1.8446E-06	-5.3418E-05	-2.4379E-04
Pile N.	10	1	3	1	1	1

* PILE TOP REACTIONS, GLOBAL *

	FOR. X, KN	FOR. Y, KN	FOR. Z, KN	MOM X, KN- M	MOM Y, KN- M	MOM Z, KN- M
MINIMUM	2022.9	357.77	-158.86	-0.4898	218.85	678.47
Pile N.	3	8	10	1	6	8
MAXIMUM	7129.1	535.89	-102.97	-0.4898	321.31	987.59
Pile N.	10	1	6	1	10	1

* PILE TOP DISPLACEMENTS, LOCAL *

	DISP. x, M	DISP. y, M	DISP. z, M	ROT. x,RAD	ROT. y,RAD	ROT. z,RAD
MINIMUM	1.0155E-03	1.9448E-03	-5.2820E-04	-1.8446E-06	-5.3418E-05	-2.4379E-04
Pile N.	3	10	1	1	1	1
MAXIMUM	3.9308E-03	1.9697E-03	-5.1160E-04	-1.8446E-06	-5.3418E-05	-2.4379E-04
Pile N.	10	1	3	1	1	1

* PILE TOP REACTIONS, LOCAL *

	AXIAL, KN	LAT. y, KN	LAT. z, KN	MOM x, KN- M	MOM y, KN- M	MOM z, KN- M
MINIMUM	2022.9	357.77	-158.86	-0.4898	218.85	678.47
Pile N.	3	8	10	1	6	8
MAXIMUM	7129.1	535.89	-102.97	-0.4898	321.31	987.59
Pile N.	10	1	6	1	10	1

* EFFECTS FOR Laterally LOADED PILE *

PILE	DISPL. y-Dir M	DISPL. z-Dir M	MOMENT z-Dir KN- M	MOMENT y-Dir KN- M	SHEAR y-Dir KN	SHEAR z-Dir KN	SOIL REACT y-Dir KN/ M	SOIL REACT z-Dir KN/ M	TOTAL STRESS KN/ M**2
Min.	-2.5672E-05	-5.2820E-04	-987.59	-161.14	-149.41	-158.90	-92.010	-36.772	1144.7
Pile N.	10	1	1	10	10	10	10	10	3
Max.	1.9697E-03	6.7866E-06	589.12	321.31	535.99	41.481	126.81	25.611	7140.9
Pile N.	1	10	1	10	1	10	10	10	10

LOAD CASE : 12

* TABLE L * COMPUTATION ON PILE CAP

* EQUIVALENT CONCENTRATED LOAD AT ORIGIN *

LOAD X, KN	LOAD Y, KN	LOAD Z, KN	MOM X, KN- M	MOM Y, KN- M	MOM Z, KN- M
60235.3	2145.00	-2125.00	-438.000	-34225.5	-26581.5

* DISPLACEMENT OF GROUPED PILE FOUNDATION AT ORIGIN *

DISP X, M	DISP Y, M	DISP Z, M	ROT X,RAD	ROT Y,RAD	ROT Z,RAD
2.60113E-03	6.45474E-04	-5.61873E-04	-2.02594E-06	-6.80625E-05	-9.96832E-05

* PILE TOP DISPLACEMENTS, GLOBAL *

	DISP. X, M	DISP. Y, M	DISP. Z, M	ROT. X,RAD	ROT. Y,RAD	ROT. Z,RAD
MINIMUM	1.6931E-03	6.3180E-04	-5.7099E-04	-2.0259E-06	-6.8062E-05	-9.9683E-05
Pile N.	3	10	1	1	1	1
MAXIMUM	3.5091E-03	6.5915E-04	-5.5276E-04	-2.0259E-06	-6.8062E-05	-9.9683E-05
Pile N.	10	1	3	1	1	1

* PILE TOP REACTIONS, GLOBAL *

	FOR. X, KN	FOR. Y, KN	FOR. Z, KN	MOM X, KN- M	MOM Y, KN- M	MOM Z, KN- M
MINIMUM	3309.3	149.93	-222.60	-0.5379	282.78	233.42
Pile N.	3	8	10	1	5	8

APPALTATORE:

Consorzio

Soci



ITINERARIO NAPOLI – BARI

PROGETTAZIONE:

Mandataria

Mandanti



RADDOPPIO TRATTA APICE – ORSARA
I LOTTO FUNZIONALE APICE – HIRPINIA

PROGETTO ESECUTIVO

RELAZIONE DI CALCOLO FONDAZIONI SPALLA A

COMMESSA IF1N	LOTTO 01 E ZZ	CODIFICA RG	DOCUMENTO MD0000 001	REV. B	FOGLIO 107 di 109
------------------	------------------	----------------	-------------------------	-----------	-------------------------

MAXIMUM	6595.7	215.30	-148.23	-0.5379	400.87	330.24
Pile N.	10	10	5	1	10	1

* PILE TOP DISPLACEMENTS, LOCAL *

	DISP. x, M	DISP. y, M	DISP. z, M	ROT. x,RAD	ROT. y,RAD	ROT. z,RAD
MINIMUM	1.6931E-03	6.3180E-04	-5.7099E-04	-2.0259E-06	-6.8062E-05	-9.9683E-05
Pile N.	3	10	1	1	1	1
MAXIMUM	3.5091E-03	6.5915E-04	-5.5276E-04	-2.0259E-06	-6.8062E-05	-9.9683E-05
Pile N.	10	1	3	1	1	1

* PILE TOP REACTIONS, LOCAL *

	AXIAL, KN	LAT. y, KN	LAT. z, KN	MOM x, KN- M	MOM y, KN- M	MOM z, KN- M
MINIMUM	3309.3	149.93	-222.60	-0.5379	282.78	233.42
Pile N.	3	8	10	1	5	8
MAXIMUM	6595.7	215.30	-148.23	-0.5379	400.87	330.24
Pile N.	10	10	5	1	10	1

* EFFECTS FOR LATERALLY LOADED PILE *

PILE	DISPL. y-DIR M	DISPL. z-DIR M	MOMENT z-DIR KN- M	MOMENT y-DIR KN- M	SHEAR y-DIR KN	SHEAR z-DIR KN	SOIL REACT y-DIR KN/ M	SOIL REACT z-DIR KN/ M	TOTAL STRESS KN/ M**2
Min.	-1.3079E-05	-5.7099E-04	-330.24	-209.49	-58.078	-222.64	-30.899	-58.481	1872.7
Pile N.	10	1	10	10	10	10	10	10	3
Max.	6.5915E-04	1.1374E-05	231.39	400.87	215.34	53.169	58.381	29.436	5293.8
Pile N.	1	10	10	10	10	10	10	10	10

LOAD CASE : 13

* TABLE L * COMPUTATION ON PILE CAP

* EQUIVALENT CONCENTRATED LOAD AT ORIGIN *

LOAD X, KN	LOAD Y, KN	LOAD Z, KN	MOM X, KN- M	MOM Y, KN- M	MOM Z, KN- M
60235.3	3010.00	-2125.00	-438.000	-34225.5	-35748.0

* DISPLACEMENT OF GROUPED PILE FOUNDATION AT ORIGIN *

DISP X, M	DISP Y, M	DISP Z, M	ROT X,RAD	ROT Y,RAD	ROT Z,RAD
2.61025E-03	9.47832E-04	-5.98675E-04	-1.29325E-06	-7.00621E-05	-1.37890E-04

* PILE TOP DISPLACEMENTS, GLOBAL *

	DISP. X, M	DISP. Y, M	DISP. Z, M	ROT. X,RAD	ROT. Y,RAD	ROT. Z,RAD
MINIMUM	1.5168E-03	9.3910E-04	-6.0449E-04	-1.2933E-06	-7.0062E-05	-1.3789E-04
Pile N.	3	10	1	1	1	1
MAXIMUM	3.7037E-03	9.5656E-04	-5.9285E-04	-1.2933E-06	-7.0062E-05	-1.3789E-04
Pile N.	10	1	3	1	1	1

* PILE TOP REACTIONS, GLOBAL *

	FOR. X, KN	FOR. Y, KN	FOR. Z, KN	MOM X, KN- M	MOM Y, KN- M	MOM Z, KN- M
MINIMUM	2974.6	210.99	-219.66	-0.3434	294.71	354.78
Pile N.	3	5	10	1	5	8
MAXIMUM	6841.8	305.90	-149.41	-0.3434	407.29	496.55
Pile N.	10	10	5	1	10	10

* PILE TOP DISPLACEMENTS, LOCAL *

	DISP. x, M	DISP. y, M	DISP. z, M	ROT. x,RAD	ROT. y,RAD	ROT. z,RAD
MINIMUM	1.5168E-03	9.3910E-04	-6.0449E-04	-1.2933E-06	-7.0062E-05	-1.3789E-04
Pile N.	3	10	1	1	1	1
MAXIMUM	3.7037E-03	9.5656E-04	-5.9285E-04	-1.2933E-06	-7.0062E-05	-1.3789E-04
Pile N.	10	1	3	1	1	1

* PILE TOP REACTIONS, LOCAL *

	AXIAL, KN	LAT. y, KN	LAT. z, KN	MOM x, KN- M	MOM y, KN- M	MOM z, KN- M
MINIMUM	2974.6	210.99	-219.66	-0.3434	294.71	354.78
Pile N.	3	5	10	1	5	8
MAXIMUM	6841.8	305.90	-149.41	-0.3434	407.29	496.55
Pile N.	10	10	5	1	10	10

* EFFECTS FOR LATERALLY LOADED PILE *

PILE	DISPL. y-DIR M	DISPL. z-DIR M	MOMENT z-DIR KN- M	MOMENT y-DIR KN- M	SHEAR y-DIR KN	SHEAR z-DIR KN	SOIL REACT y-DIR KN/ M	SOIL REACT z-DIR KN/ M	TOTAL STRESS KN/ M**2
Min.	-1.8019E-05	-6.0449E-04	-496.55	-215.01	-84.067	-219.71	-46.465	-56.261	1683.3
Pile N.	10	1	10	10	10	10	10	10	3
Max.	9.5656E-04	1.1269E-05	331.32	407.29	305.96	54.844	80.164	31.220	5809.9
Pile N.	1	10	10	10	10	10	10	10	10

LOAD CASE : 14

* TABLE L * COMPUTATION ON PILE CAP

APPALTATORE:

Consorzio

Soci



ITINERARIO NAPOLI – BARI

PROGETTAZIONE:

Mandataria

Mandanti



RADDOPPIO TRATTA APICE – ORSARA
I LOTTO FUNZIONALE APICE – HIRPINIA

PROGETTO ESECUTIVO

RELAZIONE DI CALCOLO FONDAZIONI SPALLA A

COMMESSA IF1N	LOTTO 01 E ZZ	CODIFICA RG	DOCUMENTO MD0000 001	REV. B	FOGLIO 108 di 109
------------------	------------------	----------------	-------------------------	-----------	-------------------------

* EQUIVALENT CONCENTRATED LOAD AT ORIGIN *

LOAD X, KN	LOAD Y, KN	LOAD Z, KN	MOM X, KN- M	MOM Y, KN- M	MOM Z, KN- M
38347.3	623.000	-1806.00	-502.000	-28049.0	-8915.50

* DISPLACEMENT OF GROUPED PILE FOUNDATION AT ORIGIN *

DISP X, M	DISP Y, M	DISP Z, M	ROT X,RAD	ROT Y,RAD	ROT Z,RAD
1.63324E-03	1.76883E-04	-4.20192E-04	-2.87471E-06	-5.40721E-05	-3.16299E-05

* PILE TOP DISPLACEMENTS, GLOBAL *

	DISP. X, M	DISP. Y, M	DISP. Z, M	ROT. X,RAD	ROT. Y,RAD	ROT. Z,RAD
	*****	*****	*****	*****	*****	*****
MINIMUM	1.1259E-03	1.5748E-04	-4.3313E-04	-2.8747E-06	-5.4072E-05	-3.1630E-05
Pile N.	3	10	1	1	1	1
MAXIMUM	2.1406E-03	1.9629E-04	-4.0726E-04	-2.8747E-06	-5.4072E-05	-3.1630E-05
Pile N.	10	1	3	1	1	1

* PILE TOP REACTIONS, GLOBAL *

	FOR. X, KN	FOR. Y, KN	FOR. Z, KN	MOM X, KN- M	MOM Y, KN- M	MOM Z, KN- M
	*****	*****	*****	*****	*****	*****
MINIMUM	2232.5	41.747	-195.56	-0.7633	221.60	50.045
Pile N.	3	8	10	1	5	8
MAXIMUM	4158.7	62.811	-124.33	-0.7633	332.58	92.956
Pile N.	10	1	5	1	10	1

* PILE TOP DISPLACEMENTS, LOCAL *

	DISP. x, M	DISP. y, M	DISP. z, M	ROT. x,RAD	ROT. y,RAD	ROT. z,RAD
	*****	*****	*****	*****	*****	*****
MINIMUM	1.1259E-03	1.5748E-04	-4.3313E-04	-2.8747E-06	-5.4072E-05	-3.1630E-05
Pile N.	3	10	1	1	1	1
MAXIMUM	2.1406E-03	1.9629E-04	-4.0726E-04	-2.8747E-06	-5.4072E-05	-3.1630E-05
Pile N.	10	1	3	1	1	1

* PILE TOP REACTIONS, LOCAL *

	AXIAL, KN	LAT. y, KN	LAT. z, KN	MOM x, KN- M	MOM y, KN- M	MOM z, KN- M
	*****	*****	*****	*****	*****	*****
MINIMUM	2232.5	41.747	-195.56	-0.7633	221.60	50.045
Pile N.	3	8	10	1	5	8
MAXIMUM	4158.7	62.811	-124.33	-0.7633	332.58	92.956
Pile N.	10	1	5	1	10	1

* EFFECTS FOR LATERALLY LOADED PILE *

PILE	DISPL. y-DIR	DISPL. z-DIR	MOMENT z-DIR	MOMENT y-DIR	SHEAR y-DIR	SHEAR z-DIR	SOIL REACT y-DIR	SOIL REACT z-DIR	TOTAL STRESS
	M	M	KN- M	KN- M	KN	KN	KN/ M	KN/ M	KN/ M**2
*****	*****	*****	*****	*****	*****	*****	*****	*****	*****
Min.	-4.0925E-06	-4.3313E-04	-92.956	-166.84	-15.863	-195.59	-8.4793	-55.620	1263.3
Pile N.	1	1	1	10	1	10	1	10	3
Max.	1.9629E-04	9.5040E-06	67.784	332.58	62.815	41.819	17.945	21.985	3374.1
Pile N.	1	10	1	10	1	10	1	10	10

LOAD CASE : 15

* TABLE L * COMPUTATION ON PILE CAP

* EQUIVALENT CONCENTRATED LOAD AT ORIGIN *

LOAD X, KN	LOAD Y, KN	LOAD Z, KN	MOM X, KN- M	MOM Y, KN- M	MOM Z, KN- M
54209.3	2021.00	-1743.00	-382.000	-37556.5	-24825.5

* DISPLACEMENT OF GROUPED PILE FOUNDATION AT ORIGIN *

DISP X, M	DISP Y, M	DISP Z, M	ROT X,RAD	ROT Y,RAD	ROT Z,RAD
2.32954E-03	5.84590E-04	-4.83044E-04	-1.70383E-06	-7.00951E-05	-9.08900E-05

* PILE TOP DISPLACEMENTS, GLOBAL *





	DISP. X, M	DISP. Y, M	DISP. Z, M	ROT. X,RAD	ROT. Y,RAD	ROT. Z,RAD
	*****	*****	*****	*****	*****	*****
MINIMUM	1.4474E-03	5.7309E-04	-4.9071E-04	-1.7038E-06	-7.0095E-05	-9.0890E-05
Pile N.	3	10	1	1	1	1
MAXIMUM	3.2117E-03	5.9609E-04	-4.7538E-04	-1.7038E-06	-7.0095E-05	-9.0890E-05
Pile N.	10	1	3	1	1	1

* PILE TOP REACTIONS, GLOBAL *

	FOR. X, KN	FOR. Y, KN	FOR. Z, KN	MOM X, KN- M	MOM Y, KN- M	MOM Z, KN- M
	*****	*****	*****	*****	*****	*****
MINIMUM	2842.8	141.22	-184.27	-0.4524	201.03	217.91
Pile N.	3	8	10	1	5	8
MAXIMUM	6192.1	203.46	-120.67	-0.4524	299.86	308.80
Pile N.	10	10	5	1	10	1

* PILE TOP DISPLACEMENTS, LOCAL *

	DISP. x, M	DISP. y, M	DISP. z, M	ROT. x,RAD	ROT. y,RAD	ROT. z,RAD
	*****	*****	*****	*****	*****	*****
MINIMUM	1.4474E-03	5.7309E-04	-4.9071E-04	-1.7038E-06	-7.0095E-05	-9.0890E-05
Pile N.	3	10	1	1	1	1
MAXIMUM	3.2117E-03	5.9609E-04	-4.7538E-04	-1.7038E-06	-7.0095E-05	-9.0890E-05
Pile N.	10	1	3	1	1	1

APPALTATORE: Consorzio <u>Soci</u>   			ITINERARIO NAPOLI – BARI RADDOPPIO TRATTA APICE – ORSARA I LOTTO FUNZIONALE APICE – HIRPINIA					
PROGETTAZIONE: <u>Mandataria</u> <u>Mandanti</u>   								
PROGETTO ESECUTIVO RELAZIONE DI CALCOLO FONDAZIONI SPALLA A								

* PILE TOP REACTIONS, LOCAL *

	AXIAL, KN	LAT. y, KN	LAT. z, KN	MOM x, KN- M	MOM y, KN- M	MOM z, KN- M
MINIMUM	2842.8	141.22	-184.27	-0.4524	201.03	217.91
Pile N.	3	8	10	1	5	8
MAXIMUM	6192.1	203.46	-120.67	-0.4524	299.86	308.80
Pile N.	10	10	5	1	10	1

* EFFECTS FOR LATERALLY LOADED PILE *

PILE	DISPL. y-DIR M	DISPL. z-DIR M	MOMENT z-DIR KN- M	MOMENT y-DIR KN- M	SHEAR y-DIR KN	SHEAR z-DIR KN	SOIL REACT y-DIR KN/ M	SOIL REACT z-DIR KN/ M	TOTAL STRESS KN/ M**2
Min.	-1.2236E-05	-4.9071E-04	-308.80	-182.69	-53.489	-184.30	-28.067	-50.211	1608.7
Pile N.	10	1	1	10	10	10	1	10	3
Max.	5.9609E-04	1.0279E-05	213.25	299.86	203.49	45.850	56.197	24.462	4798.4
Pile N.	1	10	10	10	10	10	10	10	10

LOAD CASE : 16

* TABLE L * COMPUTATION ON PILE CAP

* EQUIVALENT CONCENTRATED LOAD AT ORIGIN *

LOAD X, KN	LOAD Y, KN	LOAD Z, KN	MOM X, KN- M	MOM Y, KN- M	MOM Z, KN- M
56653.3	5158.00	-1498.00	-716.000	-24450.0	-61609.0

* DISPLACEMENT OF GROUPED PILE FOUNDATION AT ORIGIN *

DISP X, M	DISP Y, M	DISP Z, M	ROT X,RAD	ROT Y,RAD	ROT Z,RAD
2.47314E-03	1.95722E-03	-5.19897E-04	-1.84463E-06	-5.34183E-05	-2.43791E-04

* PILE TOP DISPLACEMENTS, GLOBAL *

	DISP. X, M	DISP. Y, M	DISP. Z, M	ROT. X,RAD	ROT. Y,RAD	ROT. Z,RAD
MINIMUM	1.0155E-03	1.9448E-03	-5.2820E-04	-1.8446E-06	-5.3418E-05	-2.4379E-04
Pile N.	3	10	1	1	1	1
MAXIMUM	3.9308E-03	1.9697E-03	-5.1160E-04	-1.8446E-06	-5.3418E-05	-2.4379E-04
Pile N.	10	1	3	1	1	1

* PILE TOP REACTIONS, GLOBAL *

	FOR. X, KN	FOR. Y, KN	FOR. Z, KN	MOM X, KN- M	MOM Y, KN- M	MOM Z, KN- M
MINIMUM	2022.9	357.77	-158.86	-0.4898	218.85	678.47
Pile N.	3	8	10	1	6	8
MAXIMUM	7129.1	535.89	-102.97	-0.4898	321.31	987.59
Pile N.	10	1	6	1	10	1

* PILE TOP DISPLACEMENTS, LOCAL *

	DISP. x, M	DISP. y, M	DISP. z, M	ROT. x,RAD	ROT. y,RAD	ROT. z,RAD
MINIMUM	1.0155E-03	1.9448E-03	-5.2820E-04	-1.8446E-06	-5.3418E-05	-2.4379E-04
Pile N.	3	10	1	1	1	1
MAXIMUM	3.9308E-03	1.9697E-03	-5.1160E-04	-1.8446E-06	-5.3418E-05	-2.4379E-04
Pile N.	10	1	3	1	1	1

* PILE TOP REACTIONS, LOCAL *

	AXIAL, KN	LAT. y, KN	LAT. z, KN	MOM x, KN- M	MOM y, KN- M	MOM z, KN- M
MINIMUM	2022.9	357.77	-158.86	-0.4898	218.85	678.47
Pile N.	3	8	10	1	6	8
MAXIMUM	7129.1	535.89	-102.97	-0.4898	321.31	987.59
Pile N.	10	1	6	1	10	1

* EFFECTS FOR LATERALLY LOADED PILE *

PILE	DISPL. y-DIR M	DISPL. z-DIR M	MOMENT z-DIR KN- M	MOMENT y-DIR KN- M	SHEAR y-DIR KN	SHEAR z-DIR KN	SOIL REACT y-DIR KN/ M	SOIL REACT z-DIR KN/ M	TOTAL STRESS KN/ M**2
Min.	-2.5672E-05	-5.2820E-04	-987.59	-161.14	-149.41	-158.90	-92.010	-36.772	1144.7
Pile N.	10	1	1	10	10	10	10	10	3
Max.	1.9697E-03	6.7866E-06	589.12	321.31	535.99	41.481	126.81	25.611	7140.9
Pile N.	1	10	1	10	1	10	10	10	10