

COMMITTENTE:



DIREZIONE LAVORI:



APPALTATORE:
CONSORZIO:



SOCI:



PROGETTAZIONE:
MANDATARIA:



MANDANTI:



PROGETTO ESECUTIVO

ITINERARIO NAPOLI - BARI RADDOPPIO TRATTA APICE - ORSARA I LOTTO FUNZIONALE APICE - HIRPINIA

VIADOTTI

VI04 - VIADOTTO UFITA APICE DA KM 16+713 A KM 17+418

RELAZIONE DI CALCOLO FONDAZIONI PILE P1, P2, P21, P22, P23 E P24

APPALTATORE	DIRETTORE DELLA PROGETTAZIONE	PROGETTISTA
Consorzio HIRPINIA AV Il Direttore Tecnico Ing. Vincenzo Moriello 10/06/2020	Il Responsabile integrazione fra le varie prestazioni specialistiche Ing. G. Cassani	 Ing. Paolo Galvanin

COMMESSA LOTTO FASE ENTE TIPO DOC. OPERA/DISCIPLINA Progr. REV. SCALA:

IF28 01 E ZZ CL VI0403 002 B -

Rev.	Descrizione	Redatto	Data	Verificato	Data	Approvato	Data	Autorizzato Data
A	Emissione per consegna	P.Pazzaglia	21/02/2020	L.Zanelotti	21/02/2020	M.Vernaleone	21/02/2020	P.Galvanin
B	Recepimento Istrutorie	P.Pazzaglia	10/06/2020	L.Zanelotti	10/06/2020	M.Vernaleone	10/06/2020	
								10/06/2020

File: IF2801EZZCLVI0403002B

n. Elab.:





APPALTATORE: <u>Consorzio</u> <u>Soci</u> HIRPINIA AV SALINI IMPREGILO S.P.A. ASTALDI S.P.A.	ITINERARIO NAPOLI – BARI RADDOPPIO TRATTA APICE – ORSARA I LOTTO FUNZIONALE APICE – HIRPINIA					
PROGETTAZIONE: <u>Mandatario</u> <u>Mandanti</u> ROCKSOIL S.P.A. NET ENGINEERING S.P.A. ALPINA S.P.A.						
PROGETTO ESECUTIVO RELAZIONE DI CALCOLO FONDAZIONI PILE P1, P2, P21, P22, P23 E P24	COMMESSA IF28	LOTTO 01	CODIFICA E ZZ CL	DOCUMENTO VI0403 002	REV. B	FOGLIO 2 di 161

Indice

1	INTRODUZIONE	5
2	DOCUMENTI DI RIFERIMENTO E NORMATIVA.....	6
2.1	DOCUMENTI DI RIFERIMENTO.....	6
2.2	NORMATIVA E STRANDARD DI RIFERIMENTO	7
2.3	SOFTWARE	7
3	MATERIALI.....	8
3.1	ACCIAIO.....	8
3.1.1	ACCIAIO PER ARMATURA STRUTTURE IN C.A.	8
3.1.2	PROFILATI E PIASTRE METALLICHE.....	8
3.2	CALCESTRUZZO.....	8
3.2.1	CALCESTRUZZO MAGRO PER GETTI DI LIVELLAMENTO	8
3.2.2	CALCESTRUZZO PALI, DIAFRAMMI DI FONDAZIONE, CORDOLI E OPERE PROVVISORIALI	8
3.2.3	CALCESTRUZZO PER FONDAZIONI PILE E SPALLE	8
4	DESCRIZIONE DELLE FONDAZIONI E STRATIGRAFIA DI PROGETTO	10
4.1	DESCRIZIONE DEL SISTEMA FONDAZIONALE	10
4.2	STRATIGRAFIA DI RIFERIMENTO.....	10
5	CRITERI DI VERIFICA.....	11
6	SCARICHI DI FONDAZIONE	12
6.1	SCARICHI ALLA BASE DELLA PILA.....	12
6.1.1	COMBINAZIONI DELLE AZIONI AGLI STATI LIMITE ULTIMI SISMICI.....	12
6.1.2	COMBINAZIONI DELLE AZIONI AGLI STATI LIMITE ULTIMI STATICI (SLU).....	13
6.1.3	COMBINAZIONI DELLE AZIONI AGLI STATI LIMITE DI ESERCIZIO (SLE).....	13
6.2	SCARICHI A INTRADOSSO PLINTO.....	14
6.2.1	COMBINAZIONI DELLE AZIONI AGLI STATI LIMITE ULTIMI SISMICI (SLV).....	14
6.2.2	COMBINAZIONI DELLE AZIONI AGLI STATI LIMITE ULTIMI STATICI (SLU).....	15
6.2.3	COMBINAZIONI DELLE AZIONI AGLI STATI LIMITE DI ESERCIZIO (SLE).....	15
7	ANALISI DELL'INTERAZIONE FONDAZIONE-TERRENO	16
7.1	DESCRIZIONE DEL MODELLO DI CALCOLO GROUP	16
7.2	SINTESI DEI RISULTATI AGLI STATI LIMITE DI ESERCIZIO (SLE)	21
7.2.1	SPOSTAMENTI.....	23
7.3	SINTESI DEI RISULTATI AGLI STATI LIMITE ULTIMI STATICI (SLU).....	24
7.4	SINTESI DEI RISULTATI AGLI STATI LIMITE ULTIMI SISMICI (SLV).....	26

APPALTATORE: Consorzio  Soci  	ITINERARIO NAPOLI – BARI RADDOPPIO TRATTA APICE – ORSARA I LOTTO FUNZIONALE APICE – HIRPINIA																	
PROGETTAZIONE: Mandataria  Mandanti  	<table border="1" style="width: 100%; border-collapse: collapse;"> <tr> <td style="width: 16.6%;">COMMESSA</td> <td style="width: 16.6%;">LOTTO</td> <td style="width: 16.6%;">CODIFICA</td> <td style="width: 16.6%;">DOCUMENTO</td> <td style="width: 16.6%;">REV.</td> <td style="width: 16.6%;">FOGLIO</td> </tr> <tr> <td>IF28</td> <td>01</td> <td>E ZZ CL</td> <td>VI0403 002</td> <td>B</td> <td>3 di 161</td> </tr> </table>						COMMESSA	LOTTO	CODIFICA	DOCUMENTO	REV.	FOGLIO	IF28	01	E ZZ CL	VI0403 002	B	3 di 161
COMMESSA	LOTTO	CODIFICA	DOCUMENTO	REV.	FOGLIO													
IF28	01	E ZZ CL	VI0403 002	B	3 di 161													

8	VERIFICA DEI PALI DI FONDAZIONE	29
8.1.1	SHEMI ARMATURA E INCIDENZA DEL PALO	33
9	VERIFICHE ALLO SLU DI TIPO GEOTECNICO	36
9.1	VERIFICA DI CAPACITÀ PORTANTE DEL PALO SINGOLO	36
9.1.1	CAPACITÀ PORTANTE VERTICALE DEL PALO SINGOLO	37
9.1.1	VERIFICA DI CAPACITÀ PORTANTE VERTICALE DEL GRUPPO DI PALI.....	41
9.1.2	VERIFICA DI CAPACITÀ PORTANTE ORIZZONTALE DEL GRUPPO DI PALI	42
10	DIMENSIONAMENTO E VERIFICA DEL PLINTO DI FONDAZIONE [P1 P21 P22 P23 P24]	43
10.1	DESCRIZIONE DEL MODELLO	43
10.1.1	COMBINAZIONI E CARICHI	44
10.2	SOLLECITAZIONI.....	47
10.2.1	SOLLECITAZIONI SLV.....	47
10.2.2	SOLLECITAZIONI SLU	49
10.2.3	SOLLECITAZIONI SLE.....	52
10.3	VERIFICHE SLU/SLE	54
10.3.1	SOLLECITAZIONI DI VERIFICA	54
10.3.2	VERIFICHE A FLESSIONE E TAGLIO.....	57
10.4	VERIFICA PUNZONAMENTO	70
10.5	VERIFICA TIRANTE-PUNTOE.....	71
10.6	STIMA INCIDENZE DI ARMATURA.....	71
11	DIMENSIONAMENTO E VERIFICA DEL PLINTO DI FONDAZIONE [P2]	72
11.1	DESCRIZIONE DEL MODELLO	72
11.1.1	COMBINAZIONI E CARICHI	73
11.2	SOLLECITAZIONI.....	74
11.2.1	SOLLECITAZIONI SLV.....	74
11.2.2	SOLLECITAZIONI SLU	76
11.2.3	SOLLECITAZIONI SLE.....	79
11.3	VERIFICHE SLU/SLE	81
11.3.1	SOLLECITAZIONI DI VERIFICA	81
11.3.2	VERIFICHE A FLESSIONE E TAGLIO.....	85
11.4	VERIFICA PUNZONAMENTO	100
11.5	STIMA INCIDENZE DI ARMATURA.....	100
12	ALLEGATO: TABULATI GROUP.....	101
12.1	PILA SLE.....	101
12.2	PILA SLU – SLV.....	113

<p>APPALTATORE:</p> <p>Consortio Soci</p> <p>  </p>	<p>ITINERARIO NAPOLI – BARI</p> <p>RADDOPPIO TRATTA APICE – ORSARA</p> <p>I LOTTO FUNZIONALE APICE – HIRPINIA</p>																	
<p>PROGETTAZIONE:</p> <p>Mandataria Mandanti</p> <p>  </p>							<table border="1" style="width: 100%; border-collapse: collapse;"> <tr> <td style="width: 16.6%;">COMMESSA</td> <td style="width: 16.6%;">LOTTO</td> <td style="width: 16.6%;">CODIFICA</td> <td style="width: 16.6%;">DOCUMENTO</td> <td style="width: 16.6%;">REV.</td> <td style="width: 16.6%;">FOGLIO</td> </tr> <tr> <td>IF28</td> <td>01</td> <td>E ZZ CL</td> <td>VI0403 002</td> <td>B</td> <td>4 di 161</td> </tr> </table>						COMMESSA	LOTTO	CODIFICA	DOCUMENTO	REV.	FOGLIO
COMMESSA	LOTTO	CODIFICA	DOCUMENTO	REV.	FOGLIO													
IF28	01	E ZZ CL	VI0403 002	B	4 di 161													
<p>PROGETTO ESECUTIVO</p> <p>RELAZIONE DI CALCOLO FONDAZIONI PILE P1, P2, P21, P22, P23 E P24</p>																		

APPALTATORE: <u>Consorzio</u> <u>Soci</u> HIRPINIA AV SALINI IMPREGILO S.P.A. ASTALDI S.P.A	ITINERARIO NAPOLI – BARI RADDOPPIO TRATTA APICE – ORSARA I LOTTO FUNZIONALE APICE – HIRPINIA																	
PROGETTAZIONE: <u>Mandatario</u> <u>Mandanti</u> ROCKSOIL S.P.A NET ENGINEERING S.P.A. ALPINA S.P.A.	<table border="1" style="width: 100%; border-collapse: collapse;"> <tr> <td style="width: 16.6%;">COMMESSA</td> <td style="width: 16.6%;">LOTTO</td> <td style="width: 16.6%;">CODIFICA</td> <td style="width: 16.6%;">DOCUMENTO</td> <td style="width: 16.6%;">REV.</td> <td style="width: 16.6%;">FOGLIO</td> </tr> <tr> <td>IF28</td> <td>01</td> <td>E ZZ CL</td> <td>VI0403 002</td> <td>B</td> <td>5 di 161</td> </tr> </table>						COMMESSA	LOTTO	CODIFICA	DOCUMENTO	REV.	FOGLIO	IF28	01	E ZZ CL	VI0403 002	B	5 di 161
COMMESSA	LOTTO	CODIFICA	DOCUMENTO	REV.	FOGLIO													
IF28	01	E ZZ CL	VI0403 002	B	5 di 161													
PROGETTO ESECUTIVO RELAZIONE DI CALCOLO FONDAZIONI PILE P1, P2, P21, P22, P23 E P24																		

1 INTRODUZIONE

Nell'ambito della redazione del Progetto Esecutivo della tratta Apice - Orsara del Lotto 1 Apice – Irpinia - potenziamento della linea ferroviaria Napoli – Bari, la presente relazione riporta i risultati del dimensionamento e verifiche delle fondazioni – plinto su pali – delle pile P1, P2, P21, P22, P23 e P24 del Viadotto VI04 denominato Viadotto Ufita Apice.

Le pile sostengono le campate di luce 25m, costituite da n. 4 cassoncini/travi in c.a.p. affiancati e solidarizzati da una soletta in c.a. gettata in opera.

Considerate le caratteristiche geometriche, le condizioni geotecniche e l'entità dei carichi agenti, le analisi sono sviluppate in riferimento alla pila P22.

Per quanto riguarda i criteri di verifica adottati per le analisi del sistema di fondazione adottato si rimanda al documento IF2801EZZRBVI0003001: Viadotti ferroviari – Relazione sui criteri di calcolo delle fondazioni.

APPALTATORE: Consorzio  Soci  	ITINERARIO NAPOLI – BARI RADDOPPIO TRATTA APICE – ORSARA I LOTTO FUNZIONALE APICE – HIRPINIA																	
PROGETTAZIONE: Mandataria  Mandanti  							<table border="1" style="width: 100%; border-collapse: collapse;"> <tr> <td style="width: 16.6%;">COMMESSA</td> <td style="width: 16.6%;">LOTTO</td> <td style="width: 16.6%;">CODIFICA</td> <td style="width: 16.6%;">DOCUMENTO</td> <td style="width: 16.6%;">REV.</td> <td style="width: 16.6%;">FOGLIO</td> </tr> <tr> <td>IF28</td> <td>01</td> <td>E ZZ CL</td> <td>VI0403 002</td> <td>B</td> <td>6 di 161</td> </tr> </table>						COMMESSA	LOTTO	CODIFICA	DOCUMENTO	REV.	FOGLIO
COMMESSA	LOTTO	CODIFICA	DOCUMENTO	REV.	FOGLIO													
IF28	01	E ZZ CL	VI0403 002	B	6 di 161													

2 Documenti di riferimento e normativa

2.1 DOCUMENTI DI RIFERIMENTO

- 1) IF2801EZZRGVI0000001 - Relazione Tecnico-Descrittiva delle Opere Civili - Viadotti VI01, VI02, VI03 e VI04;
- 2) IF2801EZZRBVI0003001 - Relazione sui criteri di calcolo delle fondazioni;
- 3) IF2801EZZRBOC0101001 - Relazione Geotecnica Generale;
- 4) IF2801EZZF6OC0101001 - Profilo geologico - Tratta all'aperto Isca Girasole, da pk 0+000 a 2+705;
- 5) IF2801EZZF6OC0101002 - Profilo geologico - Tratta all'aperto valle Ufita, da pk 4+695 a pk 5+090;
- 6) IF2801EZZF6OC0101003 - Profilo geologico - Tratta all'aperto Castel del Fiego, da pk 9+550 a pk 10+090;
- 7) IF2801EZZF6OC0101004 - Profilo geologico - Tratta all'aperto Iscalonga, da pk 16+610 a pk 18+700;
- 8) IF2801EZZRBOC0301001 - Relazione Sismica generale;
- 9) IF2801EZZP9VI0400000 - Pianta fondazioni e sezioni (tav. 1 di 6)
- 10) IF2801EZZP9VI0400001 - Pianta fondazioni e sezioni (tav. 2 di 6)
- 11) IF2801EZZP9VI0400002 - Pianta fondazioni e sezioni (tav. 3 di 6)
- 12) IF2801EZZP9VI0400003 - Pianta fondazioni e sezioni (tav. 4 di 6)
- 13) IF2801EZZP9VI0400004 - Pianta fondazioni e sezioni (tav. 5 di 6)
- 14) IF2801EZZP9VI0400005 - Pianta fondazioni e sezioni (tav. 6 di 6)
- 15) IF2801EZZP9VI0400006 - Pianta impalcato e prospetto (tav. 1 di 6)
- 16) IF2801EZZP9VI0400007 - Pianta impalcato e prospetto (tav. 2 di 6)
- 17) IF2801EZZP9VI0400008 - Pianta impalcato e prospetto (tav. 3 di 6)
- 18) IF2801EZZP9VI0400009 - Pianta impalcato e prospetto (tav. 4 di 6)
- 19) IF2801EZZP9VI0400010 - Pianta impalcato e prospetto (tav. 5 di 6)
- 20) IF2801EZZP9VI0400011 - Pianta impalcato e prospetto (tav. 6 di 6)
- 21) IF2801EZZCLVI0404001 - Spalla A: Relazione di calcolo strutture in elevazione
- 22) IF2801EZZCLVI0405001 - Pile P1, P2, P21, P22, P23 e P24: Relazione di calcolo strutture in elevazione
- 23) IF2801EZZCLVI0405002 - Pila P3: Relazione di calcolo strutture in elevazione
- 24) IF2801EZZCLVI0405003 - Pila P4 : Relazione di calcolo strutture in elevazione
- 25) IF2801EZZCLVI0405004 - Pila P5: Relazione di calcolo strutture in elevazione
- 26) IF2801EZZCLVI0405005 - Pila P6: Relazione di calcolo strutture in elevazione
- 27) IF2801EZZCLVI0405006 - Pila da P7 a P16: Relazione di calcolo strutture in elevazione
- 28) IF2801EZZCLVI0405007 - Pile da P17 a P20: Relazione di calcolo strutture in elevazione
- 29) IF2801EZZCLVI0404002 - Spalla B: Relazione di calcolo strutture in elevazione

APPALTATORE: Consorzio  Soci  	ITINERARIO NAPOLI – BARI RADDOPPIO TRATTA APICE – ORSARA I LOTTO FUNZIONALE APICE – HIRPINIA											
PROGETTAZIONE: Mandataria  Mandanti  							<table border="1"> <tr> <td data-bbox="719 293 847 374">COMMESSA IF28</td> <td data-bbox="847 293 959 374">LOTTO 01</td> <td data-bbox="959 293 1086 374">CODIFICA E ZZ CL</td> <td data-bbox="1086 293 1246 374">DOCUMENTO VI0403 002</td> <td data-bbox="1246 293 1358 374">REV. B</td> <td data-bbox="1358 293 1479 374">FOGLIO 7 di 161</td> </tr> </table>					
COMMESSA IF28	LOTTO 01	CODIFICA E ZZ CL	DOCUMENTO VI0403 002	REV. B	FOGLIO 7 di 161							

- 30) IF2801EZZCLVI0403001 - Relazione di calcolo fondazioni spalla A e spalla B
- 31) IF2801EZZCLVI0403002 - Relazione di calcolo fondazioni pile Pile P1, P2, P21, P22,P23 e P24
- 32) IF2801EZZCLVI0403003 - Relazione di calcolo fondazioni pile P3 e P6
- 33) IF2801EZZCLVI0403004 - Relazione di calcolo fondazioni pile P4 e P5
- 34) IF2801EZZCLVI0403007 - Relazione di calcolo fondazioni pile da P7 a P16
- 35) IF2801EZZCLVI0403008 - Relazione di calcolo fondazioni pile da P17 a P20.

2.2 NORMATIVA E STRANDARD DI RIFERIMENTO

- 36) Decreto Ministeriale del 14/01/2008: “Approvazione delle Nuove Norma Tecniche per le Costruzioni”, G.U. n.29 del 04/02/20018, Supplemento Ordinario n.30;
- 37) Circolare 01/02/2009, n.617 - Istruzione per l'applicazione delle “Nuove Norme Tecniche per le Costruzioni” di cui al D.M. 14/01/2008;
- 38) DM 06/05/2008 - “Integrazione al DM 14/01/2008 di approvazione delle Nuove Norme Tecniche per le Costruzioni”;
- 39) RFI DTC SI MA IFS 001 A - “Manuale di progettazione delle opere civili”;
- 40) RFI DTC SI SP IFS 001 A - “Capitolato generale tecnico d'appalto delle opere civili”;
- 41) UNI EN 1997-1: Eurocodice 7 - Progettazione Geotecnica - Parte 1: Regole generali;
- 42) UNI EN 1998-5: Eurocodice 8 - Progettazione delle strutture per la resistenza sismica - Parte 5: Fondazioni, strutture di contenimento ed aspetti geotecnici;
- 43) Caltrans. Guidelines on Foundation Loading and Deformation Due to Liquefaction Induced Lateral Spreading. California Department of Transportation, Sacramento, California, 2012;
- 44) JRA (2002) – Specifications for Highway Bridges, JapanRoad Association. Part V: Seismic Design.

2.3 SOFTWARE

- 45) Lpile, Ensoft Inc, versione 2016, release n. 9;
- 46) Group, Ensoft Inc, versione 2016, release n.10;
- 47) GeoStru, RC-SEC, Calcolo di sezioni in Cemento Armato;
- 48) Pozzi J – Pozzi di fondazione o di stabilizzazione – VOL. 4, T. Collotta 2010.

APPALTATORE: Consorzio Soci   	ITINERARIO NAPOLI – BARI RADDOPPIO TRATTA APICE – ORSARA I LOTTO FUNZIONALE APICE – HIRPINIA																	
PROGETTAZIONE: Mandataria Mandanti   							<table border="1" style="width: 100%; border-collapse: collapse;"> <tr> <td style="width: 16.6%;">COMMESSA</td> <td style="width: 16.6%;">LOTTO</td> <td style="width: 16.6%;">CODIFICA</td> <td style="width: 16.6%;">DOCUMENTO</td> <td style="width: 16.6%;">REV.</td> <td style="width: 16.6%;">FOGLIO</td> </tr> <tr> <td>IF28</td> <td>01</td> <td>E ZZ CL</td> <td>VI0403 002</td> <td>B</td> <td>8 di 161</td> </tr> </table>						COMMESSA	LOTTO	CODIFICA	DOCUMENTO	REV.	FOGLIO
COMMESSA	LOTTO	CODIFICA	DOCUMENTO	REV.	FOGLIO													
IF28	01	E ZZ CL	VI0403 002	B	8 di 161													

3 Materiali

Il progetto strutturale delle fondazioni prevede l'uso dei materiali con le caratteristiche meccaniche minime riportate nei paragrafi seguenti.

3.1 ACCIAIO

3.1.1 Acciaio per armatura strutture in c.a.

Barre ad aderenza migliorata, saldabile, tipo B450C dotato delle seguenti caratteristiche meccaniche:

- tensione caratteristica di rottura: $f_{tk} \geq 540 \text{ MPa}$
- tensione caratteristica di snervamento: $f_{yk} \geq 450 \text{ MPa}$
- allungamento caratteristico: $\geq 7.5 \%$
- rapporto tensione di rottura/ tensione di snervamento: $1.15 \leq f_{tk}/f_{yk} < 1.35$

3.1.2 Profilati e piastre metalliche

- - Acciaio tipo: EN 10025-S275 JR
- - Tensione di rottura a trazione: $f_{tk} \geq 430 \text{ MPa}$
- - Tensione di snervamento: $f_{yk} \geq 275 \text{ MPa}$

3.2 CALCESTRUZZO

3.2.1 Calcestruzzo magro per getti di livellamento

- Classe di resistenza: C12/15
- classe di esposizione: X0

3.2.2 Calcestruzzo pali, diaframmi di fondazione, cordoli e opere provvisionali

- Classe di resistenza: C25/30
- classe di consistenza: S4
- classe di esposizione: XC2
- dimensione massima dell'inerte: $D_{max} = 32 \text{ mm}$
- copriferro minimo: $C_{f,min} \geq 60 \text{ mm}$

3.2.3 Calcestruzzo per fondazioni pile e spalle

- Classe di resistenza: C28/35
- classe di consistenza: S4
- classe di esposizione: XC2

APPALTATORE: Consorzio  Soci  	ITINERARIO NAPOLI – BARI RADDOPPIO TRATTA APICE – ORSARA I LOTTO FUNZIONALE APICE – HIRPINIA											
PROGETTAZIONE: Mandataria  Mandanti  							<table border="1"> <tr> <td data-bbox="724 293 863 378"> COMMESSA IF28 </td> <td data-bbox="868 293 959 378"> LOTTO 01 </td> <td data-bbox="963 293 1102 378"> CODIFICA E ZZ CL </td> <td data-bbox="1107 293 1294 378"> DOCUMENTO VI0403 002 </td> <td data-bbox="1299 293 1390 378"> REV. B </td> <td data-bbox="1394 293 1482 378"> FOGLIO 9 di 161 </td> </tr> </table>					
COMMESSA IF28	LOTTO 01	CODIFICA E ZZ CL	DOCUMENTO VI0403 002	REV. B	FOGLIO 9 di 161							

- dimensione massima dell'inerte: $D_{max} = 25 \text{ mm}$
- copriferro minimo: $C_{f,min} \geq 40 \text{ mm}$

APPALTATORE: Consorzio Soci   	ITINERARIO NAPOLI – BARI RADDOPPIO TRATTA APICE – ORSARA I LOTTO FUNZIONALE APICE – HIRPINIA					
PROGETTAZIONE: Mandataria Mandanti   						
PROGETTO ESECUTIVO RELAZIONE DI CALCOLO FONDAZIONI PILE P1, P2, P21, P22, P23 E P24	COMMESSA IF28	LOTTO 01	CODIFICA E ZZ CL	DOCUMENTO VI0403 002	REV. B	FOGLIO 10 di 161

4 DESCRIZIONE DELLE FONDAZIONI E STRATIGRAFIA DI PROGETTO

4.1 DESCRIZIONE DEL SISTEMA FONDAZIONALE

La fondazione della pila P22 è costituita da: un plinto a sezione quadrata di dimensioni 12.0 m x 12.0 m² e altezza di 2.5 m posto su n.9 pali trivellati di diametro $\varnothing = 1500$ mm e lunghezza L = 30.0 m.

4.2 STRATIGRAFIA DI RIFERIMENTO



In accordo con quanto riportato nella Relazione Geotecnica Generale - ref. 3), la stratigrafia e i parametri geotecnici di riferimento sono riportati nella seguente Tabella 1 unitamente alla portanza limite laterale e di base dei diaframmi.

La quota piano campagna di riferimento è ca. 154.70 m s.l.m.. Si considera la profondità della testa del palo da p.c. di ca. 4.5 m.

STRATIGRAFIA da quota testa palo				PARAMETRI GEOTECNICI DI RIFERIMENTO			PORTANZA LIMITE DEGLI ELEMENTI FONDAZIONE	
DA	A	ΔH	UNITA' DI RIFERIMENTO	γ	φ	Cu	qs	qb
[m]	[m]	[m]		[kN/m ³]	[°]	[kPa]	[kPa]	[kPa]
0	4	4	ALL2-S	19	29	-	40	-
4	11	7	BNA3	20.5		115	80.43	2274.9
11	16	5	BNA3	20.5	33		95	2950
16	25.5	9.5	BNA3	20.5		220	111.24	3146.9
25.5	35.5	10	BNA3	20.5	33		165	4300
35.5	BNA3	20.5		300	129.9	3674.2

Tabella 1 Stratigrafia e parametri geotecnici di riferimento

La falda è assunta a 1.0 m da quota testa palo.

APPALTATORE: Consorzio Soci   	ITINERARIO NAPOLI – BARI RADDOPPIO TRATTA APICE – ORSARA I LOTTO FUNZIONALE APICE – HIRPINIA																
PROGETTAZIONE: Mandataria Mandanti   	<table border="1" style="width: 100%; border-collapse: collapse;"> <tr> <td style="width: 15%;">COMMESSA</td> <td style="width: 15%;">LOTTO</td> <td style="width: 15%;">CODIFICA</td> <td style="width: 15%;">DOCUMENTO</td> <td style="width: 15%;">REV.</td> <td style="width: 15%;">FOGLIO</td> </tr> <tr> <td>IF28</td> <td>01</td> <td>E ZZ CL</td> <td>VI0403 002</td> <td>B</td> <td>11 di 161</td> </tr> </table>					COMMESSA	LOTTO	CODIFICA	DOCUMENTO	REV.	FOGLIO	IF28	01	E ZZ CL	VI0403 002	B	11 di 161
COMMESSA	LOTTO	CODIFICA	DOCUMENTO	REV.	FOGLIO												
IF28	01	E ZZ CL	VI0403 002	B	11 di 161												
PROGETTO ESECUTIVO RELAZIONE DI CALCOLO FONDAZIONI PILE P1, P2, P21, P22, P23 E P24																	

5 CRITERI DI VERIFICA

Per ogni stato limite ultimo deve essere rispettata la condizione:

$$Ed \leq Rd;$$

dove Ed è il valore di progetto dell'azione o dell'effetto dell'azione e Rd è il valore di progetto della resistenza.

Le verifiche sono sviluppate secondo l'approccio 2:

combinazione: A1+M1+R3,

in cui è previsto un'unica combinazione di gruppi di coefficienti, da adottare sia nelle verifiche strutturali (STR) sia nelle verifiche geotecniche (GEO).

Per maggiori dettagli sui criteri di calcolo e verifica si rimanda alla relazione ref. 2).

Per le verifiche a fessurazione si ricorda che sono svolte per condizioni ambientali ordinarie e armature poco sensibili (vedasi § 9.3.1 di ref. 2)).

APPALTATORE: Consorzio Soci 	ITINERARIO NAPOLI – BARI RADDOPPIO TRATTA APICE – ORSARA I LOTTO FUNZIONALE APICE – HIRPINIA																	
PROGETTAZIONE: Mandataria Mandanti 							<table border="1" style="width: 100%; border-collapse: collapse;"> <tr> <td style="width: 16.6%;">COMMESSA</td> <td style="width: 16.6%;">LOTTO</td> <td style="width: 16.6%;">CODIFICA</td> <td style="width: 16.6%;">DOCUMENTO</td> <td style="width: 16.6%;">REV.</td> <td style="width: 16.6%;">FOGLIO</td> </tr> <tr> <td>IF28</td> <td>01</td> <td>E ZZ CL</td> <td>VI0403 002</td> <td>B</td> <td>12 di 161</td> </tr> </table>						COMMESSA	LOTTO	CODIFICA	DOCUMENTO	REV.	FOGLIO
COMMESSA	LOTTO	CODIFICA	DOCUMENTO	REV.	FOGLIO													
IF28	01	E ZZ CL	VI0403 002	B	12 di 161													

6 SCARICHI DI FONDAZIONE

Di seguito si esaminano gli scarichi a quota spiccato pila, derivanti dall'analisi strutturale complessiva del viadotto, e si valutano le azioni ad intradosso plinto considerando i trasporti delle azioni di taglio, e i contributi addizionali, in termini di azioni permanenti, dovuti ai pesi propri del plinto di fondazione e del terreno di ricoprimento definitivo.

6.1 SCARICHI ALLA BASE DELLA PILA

Di seguito si riportano gli scarichi alla base della pila per le combinazioni di carico sismiche (SLV), statiche (SLU) e di esercizio (SLE).

Nella **Figura 6-1** la convenzione dei segni assunta per le pile.



Figura 6-1: Sistema di riferimento proprio delle pile

6.1.1 Combinazioni delle azioni agli stati limite ultimi sismici

Nella seguente **Tabella 2** si riportano le combinazioni di carico più gravose agli stati limite ultimi (SLV) in presenza di sisma.

Tali carichi sono stati ottenuti considerando la struttura in elevazione in classe di duttilità B (fattore di struttura $q=1.5$). Per il dimensionamento e le verifiche del sistema fondazione le azioni da considerare sono le resistenze degli elementi strutturali soprastanti, con il limite, in accordo alle NTC 2008 (ref. 36)), che il fattore di amplificazione non superi $\gamma_{Rd} = 1.1$.

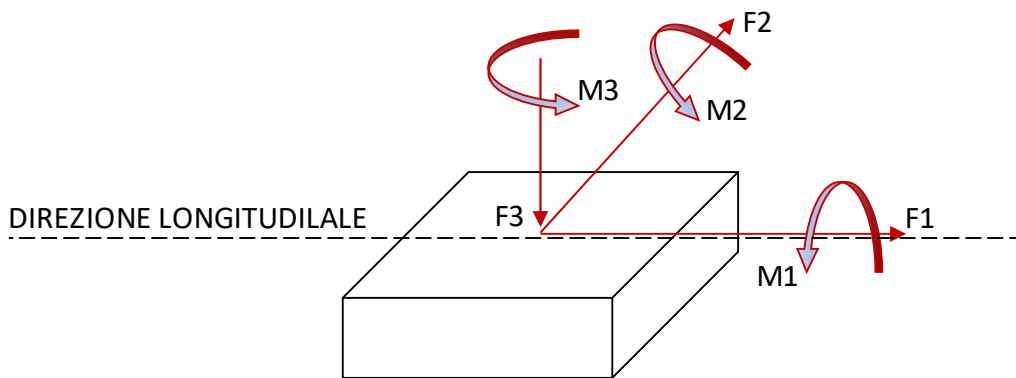
APPALTATORE: Consorzio  Soci  	ITINERARIO NAPOLI – BARI RADDOPPIO TRATTA APICE – ORSARA I LOTTO FUNZIONALE APICE – HIRPINIA					
PROGETTAZIONE: Mandataria  Mandanti  						
PROGETTO ESECUTIVO RELAZIONE DI CALCOLO FONDAZIONI PILE P1, P2, P21, P22, P23 E P24	COMMESSA IF28	LOTTO 01	CODIFICA E ZZ CL	DOCUMENTO VI0403 002	REV. B	FOGLIO 13 di 161

Sollecitazioni estradosso fondazione SLV							
sollecitazione	combinazione	F1	F2	F3	M1	M2	M3
		KN	KN	KN	KN-m	KN-m	kN-m
MAX F1	slu-SISMA6	10828	2743	11847	-23276	81909	158
MIN F1	slu-SISMA1	-10138	-2694	18004	24000	-75302	-109
MAX F2	slu-SISMA32	3367	9111	12333	-78220	25264	363
MIN F2	slu-SISMA28	-2825	-8980	18004	79998	-20404	-362
MAX F3	slu-SISMA48	-3042	-2694	27082	24158	-22604	-109
MIN F3	slu-SISMA41	3258	2694	1710	-23983	24732	109
MAX M1	slu-SISMA26	-3641	-10471	9650	95992	-26751	362
MIN M1	slu-SISMA21	4052	10547	18550	-93917	30566	-362
MAX M2	slu-SISMA6	10828	2743	11847	-23276	81909	158
MIN M2	slu-SISMA1	-10138	-2694	18004	24000	-75302	-109

Tabella 2: Combinazioni sismiche SLV: azioni agenti a base pila

6.1.2 Combinazioni delle azioni agli stati limite ultimi statici (SLU)

Nella seguente Tabella 3 si riportano le combinazioni agli stati limite ultimi statici (SLU); i carichi sono amplificati con i coefficienti parziali A1.



Sollecitazioni estradosso fondazione SLU-STR							
sollecitazione	combinazione	F1	F2	F3	M1	M2	M3
		KN	KN	KN	KN-m	KN-m	kN-m
MAX F1	slu60	3786	1067	25125	14400	35532	361
MAX F2	slu26	1340	1605	28646	21237	10149	5
MAX F3	slu52	2002	1605	28646	21237	16142	5
MIN F3	slu25	507	1232	13053	16071	4779	0
MAX M1	slu63	1404	1290	24377	24688	11544	0
MAX M2	slu60	3786	1067	25125	14400	35532	361

Tabella 3: Combinazioni statiche SLU-A1: azioni agenti a base pila

6.1.3 Combinazioni delle azioni agli stati limite di esercizio (SLE)

Nella seguente Tabella 4 si riportano le combinazioni di carico caratteristiche impiegate per gli stati limite di esercizio (SLE).

Sollecitazioni estradosso fondazione SLE-RARA							
sollecitazione	combinazione	F1	F2	F3	M1	M2	M3
		KN	KN	KN	KN-m	KN-m	kN-m
MAX F3	SLE-RARA44	-1369	-1090	20275	14425	-11021	-3

APPALTATORE: Consorzio Soci   	ITINERARIO NAPOLI – BARI RADDOPPIO TRATTA APICE – ORSARA I LOTTO FUNZIONALE APICE – HIRPINIA					
PROGETTAZIONE: Mandataria Mandanti   						
PROGETTO ESECUTIVO RELAZIONE DI CALCOLO FONDAZIONI PILE P1, P2, P21, P22, P23 E P24	COMMESSA IF28	LOTTO 01	CODIFICA E ZZ CL	DOCUMENTO VI0403 002	REV. B	FOGLIO 14 di 161

MIN F3	SLE-RARA25	-338	-821	13053	10714	-3186	0
MAX M1	SLE-RARA55	-959	-873	17331	16804	-7871	0
MAX M2	SLE-RARA85	-2605	-718	17847	9691	-24441	-248

Tabella 4: Combinazioni di esercizio SLE: azioni agenti a base pila

6.2 SCARICHI A INTRADOSSO PLINTO

6.2.1 Combinazioni delle azioni agli stati limite ultimi sismici (SLV)

Nella Tabella 6 si riportano le combinazioni di carico agli stati limite ultimi (SLV) in presenza dell'azione sismica, ottenute:

- amplificando le azioni di taglio e i momenti a base pila del coefficiente $\gamma_{Rd} = 1.1$;
- considerando il trasporto dei momenti da spiccato pila a intradosso plinto;
- aggiungendo il peso proprio del plinto e del terreno di ricoprimento (Tabella 5).

plinto	B trasv	12	m
	L long	12	m
	H	2.5	m
ricoprimento	h	1	m
	peso plinto	9000.0	kN
	peso rinterro	2880.0	kN

Tabella 5: Plinto: caratteristiche geometriche

Sollecitazioni intradosso fondazione SLV							
sollecitazione	combinazione	F1	F2	F3	M1	M2	M3
		KN	KN	KN	KN-m	KN-m	kN-m
MAX F1	slu-SISMA6	10828	2743	23727	-30135	108980	158
MIN F1	slu-SISMA1	-10138	-2694	29884	30735	-100646	-109
MAX F2	slu-SISMA32	3367	9111	24213	-100998	33681	363
MIN F2	slu-SISMA28	-2825	-8980	29884	102449	-27466	-362
MAX F3	slu-SISMA48	-3042	-2694	38962	30893	-30208	-109
MIN F3	slu-SISMA41	3258	2694	13590	-30718	32878	109
MAX M1	slu-SISMA26	-3641	-10471	21530	122170	-35855	362
MIN M1	slu-SISMA21	4052	10547	30430	-120285	40697	-362
MAX M2	slu-SISMA6	10828	2743	23727	-30135	108980	158
MIN M2	slu-SISMA1	-10138	-2694	29884	30735	-100646	-109

Tabella 6: Combinazioni sismiche SLV: azioni agenti ad intradosso plinto

APPALTATORE: Consorzio Soci   	ITINERARIO NAPOLI – BARI RADDOPPIO TRATTA APICE – ORSARA I LOTTO FUNZIONALE APICE – HIRPINIA
PROGETTAZIONE: Mandataria Mandanti   	
PROGETTO ESECUTIVO RELAZIONE DI CALCOLO FONDAZIONI PILE P1, P2, P21, P22, P23 E P24	

6.2.2 Combinazioni delle azioni agli stati limite ultimi statici (SLU)

Nella **Tabella 7** si riportano gli scarichi per gli stati limite ultimi statici (SLU), ottenuti:

- considerando il trasporto dei momenti da spiccato pila a intradosso plinto;
- aggiungendo il peso proprio del plinto e del terreno di ricoprimento (**Tabella 5**), fattorizzati per il fattore 1.3.

Sollecitazioni intradosso fondazione SLU-STR							
sollecitazione	combinazione	F1	F2	F3	M1	M2	M3
		KN	KN	KN	KN-m	KN-m	kN-m
MAX F1	slu60	3786	1067	40569	17068	44997	361
MAX F2	slu26	1340	1605	44090	25250	13499	5
MAX F3	slu52	2002	1605	44090	25250	21147	5
MIN F3	slu25	507	1232	28497	19151	6047	0
MAX M1	slu63	1404	1290	39821	27913	15054	0
MAX M2	slu60	3786	1067	40569	17068	44997	361

Tabella 7: Combinazioni di statiche SLU-A1: azioni agenti ad intradosso plinto

6.2.3 Combinazioni delle azioni agli stati limite di esercizio (SLE)

Nella **Tabella 8** si riportano le combinazioni di carico caratteristiche impiegate per gli stati limite di esercizio ottenute:

- considerando il trasporto dei momenti da spiccato pila a intradosso plinto;
- aggiungendo il peso proprio del plinto e del terreno di ricoprimento (**Tabella 5**).

Sollecitazioni estradosso fondazione SLE-RARA							
sollecitazione	combinazione	F1	F2	F3	M1	M2	M3
		KN	KN	KN	KN-m	KN-m	kN-m
MAX F3	SLE-RARA44	-1369	-1090	32155	17150	-14444	-3
MIN F3	SLE-RARA25	-338	-821	24933	12767	-4031	0
MAX M1	SLE-RARA55	-959	-873	29211	18987	-10269	0
MAX M2	SLE-RARA85	-2605	-718	29727	11486	-30954	-248

Tabella 8: Combinazioni di esercizio SLE: azioni agenti ad intradosso plinto

APPALTATORE: Consorzio Soci   	ITINERARIO NAPOLI – BARI RADDOPPIO TRATTA APICE – ORSARA I LOTTO FUNZIONALE APICE – HIRPINIA																	
PROGETTAZIONE: Mandataria Mandanti   	<table border="1" style="width: 100%; border-collapse: collapse;"> <tr> <td style="width: 16.6%;">COMMESSA</td> <td style="width: 16.6%;">LOTTO</td> <td style="width: 16.6%;">CODIFICA</td> <td style="width: 16.6%;">DOCUMENTO</td> <td style="width: 16.6%;">REV.</td> <td style="width: 16.6%;">FOGLIO</td> </tr> <tr> <td>IF28</td> <td>01</td> <td>E ZZ CL</td> <td>VI0403 002</td> <td>B</td> <td>16 di 161</td> </tr> </table>						COMMESSA	LOTTO	CODIFICA	DOCUMENTO	REV.	FOGLIO	IF28	01	E ZZ CL	VI0403 002	B	16 di 161
COMMESSA	LOTTO	CODIFICA	DOCUMENTO	REV.	FOGLIO													
IF28	01	E ZZ CL	VI0403 002	B	16 di 161													
PROGETTO ESECUTIVO RELAZIONE DI CALCOLO FONDAZIONI PILE P1, P2, P21, P22, P23 E P24																		

7 ANALISI DELL'INTERAZIONE FONDAZIONE-TERRENO

L'analisi di interazione terreno-fondazione è stata sviluppata con il software GROUP della Ensoft.

Il programma considera che il comportamento di un palo soggetto ad azioni orizzontali all'interno di un gruppo differisce da quello di un palo singolo ed isolato. In un gruppo di pali caricato da azioni orizzontali i fenomeni di interazione reciproca palo – terreno – palo determinano, complessivamente, una diminuzione della rigidità del sistema.

La diversità di comportamento si manifesta mediante un differente valore dello sforzo di taglio agente in testa a ciascun palo, differenti valori di momento flettente, diversa ubicazione del valore massimo di momento al variare della profondità (nell'ipotesi in cui il vincolo in testa al palo non sia un incastro). La modalità di risposta di ciascun palo è funzione essenzialmente dalla posizione geometrica che questo occupa all'interno del gruppo. Precisamente, la risposta del singolo palo all'interno del gruppo è condizionata:

- dalla fila di appartenenza all'interno del gruppo (effetto ombra o shadowing);
- dalla posizione all'interno della singola fila (effetto di bordo).

7.1 DESCRIZIONE DEL MODELLO DI CALCOLO GROUP

Il modello di calcolo è stato costruito nel seguente modo:







APPALTATORE: Consorzio Soci   	ITINERARIO NAPOLI – BARI RADDOPPIO TRATTA APICE – ORSARA I LOTTO FUNZIONALE APICE – HIRPINIA																	
PROGETTAZIONE: Mandataria Mandanti   	<table border="1" style="width: 100%; border-collapse: collapse;"> <tr> <td style="width: 16.6%;">COMMESSA</td> <td style="width: 16.6%;">LOTTO</td> <td style="width: 16.6%;">CODIFICA</td> <td style="width: 16.6%;">DOCUMENTO</td> <td style="width: 16.6%;">REV.</td> <td style="width: 16.6%;">FOGLIO</td> </tr> <tr> <td>IF28</td> <td>01</td> <td>E ZZ CL</td> <td>VI0403 002</td> <td>B</td> <td>17 di 161</td> </tr> </table>						COMMESSA	LOTTO	CODIFICA	DOCUMENTO	REV.	FOGLIO	IF28	01	E ZZ CL	VI0403 002	B	17 di 161
COMMESSA	LOTTO	CODIFICA	DOCUMENTO	REV.	FOGLIO													
IF28	01	E ZZ CL	VI0403 002	B	17 di 161													
PROGETTO ESECUTIVO RELAZIONE DI CALCOLO FONDAZIONI PILE P1, P2, P21, P22, P23 E P24																		



Figura 7-1: Vista frontale del modello GROUPv2016

APPALTATORE: Consorzio Soci   	ITINERARIO NAPOLI – BARI RADDOPPIO TRATTA APICE – ORSARA I LOTTO FUNZIONALE APICE – HIRPINIA					
PROGETTAZIONE: Mandataria Mandanti   						
PROGETTO ESECUTIVO RELAZIONE DI CALCOLO FONDAZIONI PILE P1, P2, P21, P22, P23 E P24	COMMESSA IF28	LOTTO 01	CODIFICA E ZZ CL	DOCUMENTO VI0403 002	REV. B	FOGLIO 18 di 161



Figura 7-2: Vista in pianta del modello GROUPv2016

In accordo al § 4.2 nelle seguenti Figura 7-3 ÷ Figura 7-9 si riporta il modello stratigrafico di calcolo e i parametri geotecnici assegnati ai singoli strati. I parametri di rigidità del terreno sono stati assunti in accordo ai criteri illustrati nella relazione al ref. 2), § 8.1.1 per le “stiff clays with free water”.

Layer	Soil Type	Depth for Top of Soil Layer (m)	Depth for Bottom of Soil Layer (m)	Properties of Layer
1	API Sand (D'Neil)	0	4	1: API Sand
2	Stiff Clay with Free Water (Reese)	4	11	2: Stiff Clay with Free Water
3	Silt (cemented c-phi)	11	16	3: Cemented c-phi Soil
4	Stiff Clay with Free Water (Reese)	16	25.5	4: Stiff Clay with Free Water
5	Silt (cemented c-phi)	25.5	35.5	5: Cemented c-phi Soil
6	Stiff Clay with Free Water (Reese)	35.5	50	6: Stiff Clay with Free Water

Figura 7-3: Modello stratigrafico GROUP V2016

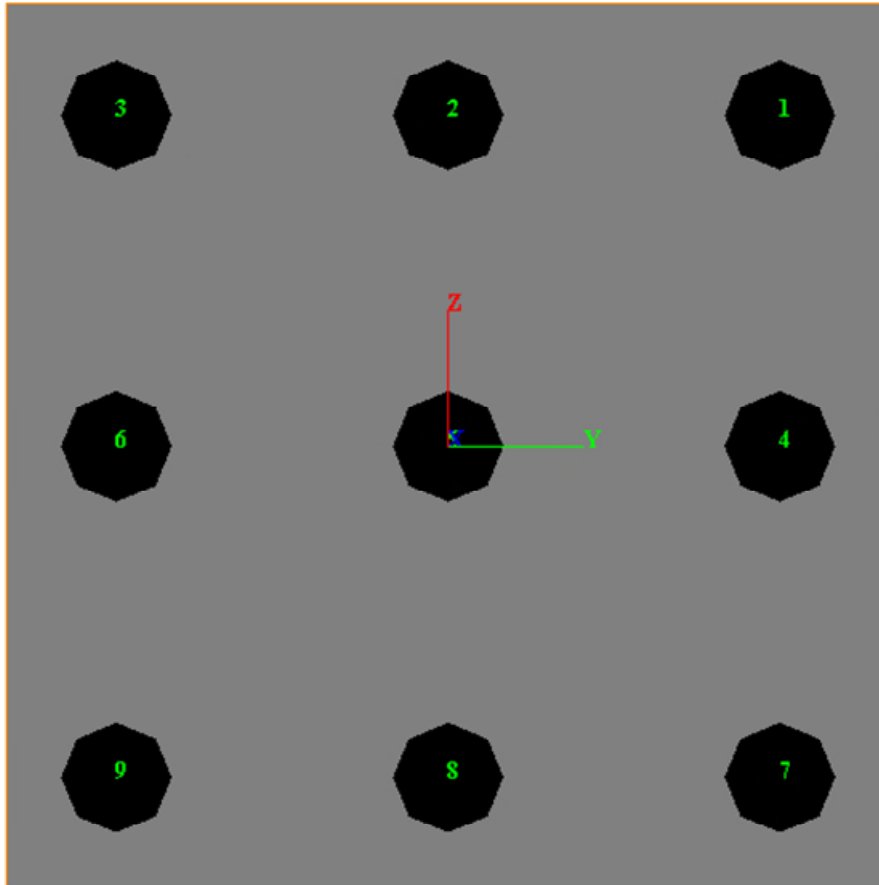
APPALTATORE: Consorzio Soci 	ITINERARIO NAPOLI – BARI RADDOPPIO TRATTA APICE – ORSARA I LOTTO FUNZIONALE APICE – HIRPINIA
PROGETTAZIONE: Mandataria Mandanti 	
PROGETTO ESECUTIVO RELAZIONE DI CALCOLO FONDAZIONI PILE P1, P2, P21, P22, P23 E P24	COMMESSA LOTTO CODIFICA DOCUMENTO REV. FOGLIO IF28 01 E ZZ CL V10403 002 B 19 di 161

API Sand 1

1=Top, 2=Bottom	Effective Unit Weight (kN/m ³)	Friction Angle (DEG.)	p-y Modulus, k (kN/m ³)	Ultimate Unit Side Friction (kN/m ²)	Ultimate Unit Tip Resistance (kN/m ²)
1	9	29	25150	40	0
2	9	29	25150	40	0

A linear interpolation with depth will be used to compute values between the top and bottom of the layer.

p-y Modulus, k:

- Always check recommended value in Geotechnical Investigation Reports.
- Program will help to estimate value for p-y Modulus, k, if zero input value is entered.

Ultimate Unit Side Friction and Ultimate Unit Tip Resistance:

- The program uses Ultimate Unit Side Friction to generate t-z curves.
- The program uses Ultimate Unit Tip Resistance to generate q-w curves.
- Always check recommended values in Geotechnical Investigation Reports.
- Program will help to estimate values for Ultimate Unit Side Friction and Ultimate Unit Tip Resistance if zero input values are entered.

Figura 7-4: Layer no.1 (ALL2-S)

Stiff Clay with Free Water 2

1=Top, 2=Bottom	Effective Unit Weight (kN/m ³)	Undrained Cohesion, c (kN/m ²)	p-y Modulus, k (kN/m ³)	Strain Factor E50	Ultimate Unit Side Friction (kN/m ²)	Ultimate Unit Tip Resistance (kN/m ²)
1	10.5	115	135000	0.007	80.43	2274.9
2	10.5	115	135000	0.007	80.43	2274.9

A linear interpolation with depth will be used to compute values between the top and bottom of the layer.

p-y Modulus, k, and Strain Factor E50:

- Always check recommended value in Geotechnical Investigation Reports.
- Program will help to estimate values for p-y Modulus, k, and Strain Factor E50 if zero input values are entered.

Ultimate Unit Side Friction and Ultimate Unit Tip Resistance:

- The program uses Ultimate Unit Side Friction to generate t-z curves.
- The program uses Ultimate Unit Tip Resistance to generate q-w curves.
- Always check recommended values in Geotechnical Investigation Reports.
- Program will help to estimate values for Ultimate Unit Side Friction and Ultimate Unit Tip Resistance if zero input values are entered.

(K=55000 per analisi SLE)

Figura 7-5: Layer no.2 (BNA3)

Cemented c-phi Soil 3

1=Top, 2=Bottom	Effective Unit Weight (kN/m ³)	Undrained Cohesion, c (kN/m ²)	Friction Angle (DEG.)	p-y Modulus, k (kN/m ³)	Strain Factor E50	Ultimate Unit Side Friction (kN/m ²)	Ultimate Unit Tip Resistance (kN/m ²)
1	10.5	10	33	125000	0.007	95	2950
2	10.5	10	33	125000	0.007	95	2950

This p-y model requires non-zero values for both cohesion and friction angle.

A linear interpolation with depth will be used to compute values between the top and bottom of the layer.

Ultimate Unit Side Friction and Ultimate Unit Tip Resistance:

- The program uses Ultimate Unit Side Friction to generate t-z curves.
- The program uses Ultimate Unit Tip Resistance to generate q-w curves.
- Always check recommended values in Geotechnical Investigation Reports.
- Program will help to estimate values for Ultimate Unit Side Friction and Ultimate Unit Tip Resistance if zero input values are entered.

(K=89000 per analisi SLE)

Figura 7-6: Layer no.3 (BNA3)

APPALTATORE: Consorzio Soci 		ITINERARIO NAPOLI – BARI					
PROGETTAZIONE: Mandataria Mandanti 		RADDOPPIO TRATTA APICE – ORSARA I LOTTO FUNZIONALE APICE – HIRPINIA					
PROGETTO ESECUTIVO RELAZIONE DI CALCOLO FONDAZIONI PILE P1, P2, P21, P22, P23 E P24		COMMESSA IF28	LOTTO 01	CODIFICA E ZZ CL	DOCUMENTO VI0403 002	REV. B	FOGLIO 20 di 161

Stiff Clay with Free Water 4

1=Top, 2=Bottom	Effective Unit Weight (kN/m ³)	Undrained Cohesion, c (kN/m ²)	p-y Modulus, k (kN/m ³)	Strain Factor E50	Ultimate Unit Side Friction (kN/m ²)	Ultimate Unit Tip Resistance (kN/m ²)
1	10.5	220	270000	0.005	111.24	3146.9
2	10.5	220	270000	0.005	111.24	3146.9

A linear interpolation with depth will be used to compute values between the top and bottom of the layer.

p-y Modulus, k, and Strain Factor E50:

- Always check recommended value in Geotechnical Investigation Reports.
- Program will help to estimate values for p-y Modulus, k, and Strain Factor E50 if zero input values are entered.

Ultimate Unit Side Friction and Ultimate Unit Tip Resistance:

- The program uses Ultimate Unit Side Friction to generate t-z curves.
- The program uses Ultimate Unit Tip Resistance to generate q-w curves.
- Always check recommended values in Geotechnical Investigation Reports.
- Program will help to estimate values for Ultimate Unit Side Friction and Ultimate Unit Tip Resistance if zero input values are entered.

(K=110000 per analisi SLE)

Figura 7-7: Layer no.4 (BNA3)

Cemented c-phi Soil 5

1=Top, 2=Bottom	Effective Unit Weight (kN/m ³)	Undrained Cohesion, c (kN/m ²)	Friction Angle (DEG.)	p-y Modulus, k (kN/m ³)	Strain Factor E50	Ultimate Unit Side Friction (kN/m ²)	Ultimate Unit Tip Resistance (kN/m ²)
1	10.5	10	33	125000	0.007	165	4300
2	10.5	10	33	125000	0.007	165	4300

This p-y model requires non-zero values for both cohesion and friction angle.

A linear interpolation with depth will be used to compute values between the top and bottom of the layer.

Ultimate Unit Side Friction and Ultimate Unit Tip Resistance:

- The program uses Ultimate Unit Side Friction to generate t-z curves.
- The program uses Ultimate Unit Tip Resistance to generate q-w curves.
- Always check recommended values in Geotechnical Investigation Reports.
- Program will help to estimate values for Ultimate Unit Side Friction and Ultimate Unit Tip Resistance if zero input values are entered.

(K=89000 per analisi SLE)

Figura 7-8: Layer no.5 (BNA3)

Stiff Clay with Free Water 6

1=Top, 2=Bottom	Effective Unit Weight (kN/m ³)	Undrained Cohesion, c (kN/m ²)	p-y Modulus, k (kN/m ³)	Strain Factor E50	Ultimate Unit Side Friction (kN/m ²)	Ultimate Unit Tip Resistance (kN/m ²)
1	10.5	300	540000	0.004	129.9	3674.2
2	10.5	300	540000	0.004	129.9	3674.2

A linear interpolation with depth will be used to compute values between the top and bottom of the layer.

p-y Modulus, k, and Strain Factor E50:

- Always check recommended value in Geotechnical Investigation Reports.
- Program will help to estimate values for p-y Modulus, k, and Strain Factor E50 if zero input values are entered.

Ultimate Unit Side Friction and Ultimate Unit Tip Resistance:

- The program uses Ultimate Unit Side Friction to generate t-z curves.
- The program uses Ultimate Unit Tip Resistance to generate q-w curves.
- Always check recommended values in Geotechnical Investigation Reports.
- Program will help to estimate values for Ultimate Unit Side Friction and Ultimate Unit Tip Resistance if zero input values are entered.

(K=220000 per analisi SLE)

Figura 7-9: Layer no.6 (BNA3)

APPALTATORE: Consorzio Soci   	ITINERARIO NAPOLI – BARI RADDOPPIO TRATTA APICE – ORSARA I LOTTO FUNZIONALE APICE – HIRPINIA																
PROGETTAZIONE: Mandataria Mandanti   	<table border="1" style="width: 100%; border-collapse: collapse;"> <tr> <td style="width: 15%;">COMMESSA</td> <td style="width: 15%;">LOTTO</td> <td style="width: 15%;">CODIFICA</td> <td style="width: 15%;">DOCUMENTO</td> <td style="width: 15%;">REV.</td> <td style="width: 15%;">FOGLIO</td> </tr> <tr> <td>IF28</td> <td>01</td> <td>E ZZ CL</td> <td>VI0403 002</td> <td>B</td> <td>21 di 161</td> </tr> </table>					COMMESSA	LOTTO	CODIFICA	DOCUMENTO	REV.	FOGLIO	IF28	01	E ZZ CL	VI0403 002	B	21 di 161
COMMESSA	LOTTO	CODIFICA	DOCUMENTO	REV.	FOGLIO												
IF28	01	E ZZ CL	VI0403 002	B	21 di 161												
PROGETTO ESECUTIVO RELAZIONE DI CALCOLO FONDAZIONI PILE P1, P2, P21, P22, P23 E P24																	

7.2 SINTESI DEI RISULTATI AGLI STATI LIMITE DI ESERCIZIO (SLE)





Si riassumono nel seguito le sollecitazioni massime di sforzo assiale, taglio e momento, agenti in testa ai pali.

Si ricorda che per le analisi allo SLE (vedasi Ref. 2)) sono stati utilizzati per le curve p-y i coefficienti di rigidezza del terreno suggeriti dal programma per carichi ciclici; facendo riferimento alle Figura 7-4 e Figura 7-9 sono stati utilizzati i valori evidenziati di lato.

SLE	FOR. X, KN	FOR.H, KN	MOM, KN-M	MOM X, KN- M
	*****	*****	*****	*****
max	5164,8	359,4	840,2	2,1
min	1436,9	84,5	193,5	-0,3

Tabella 9: Sollecitazioni allo SLE massime e minime per i pali di fondazione

Nelle seguenti figure sono diagrammati l'andamento con la profondità del momento flettente e del taglio relativi alle combinazioni in cui tali sollecitazioni risultano massime.

APPALTATORE: Consorzio Soci   	ITINERARIO NAPOLI – BARI RADDOPPIO TRATTA APICE – ORSARA I LOTTO FUNZIONALE APICE – HIRPINIA												
PROGETTAZIONE: Mandataria Mandanti   													
PROGETTO ESECUTIVO RELAZIONE DI CALCOLO FONDAZIONI PILE P1, P2, P21, P22, P23 E P24		<table border="1" style="width: 100%; border-collapse: collapse;"> <tr> <td style="width: 15%;">COMMESSA</td> <td style="width: 15%;">LOTTO</td> <td style="width: 15%;">CODIFICA</td> <td style="width: 15%;">DOCUMENTO</td> <td style="width: 15%;">REV.</td> <td style="width: 15%;">FOGLIO</td> </tr> <tr> <td>IF28</td> <td>01</td> <td>E ZZ CL</td> <td>VI0403 002</td> <td>B</td> <td>22 di 161</td> </tr> </table>	COMMESSA	LOTTO	CODIFICA	DOCUMENTO	REV.	FOGLIO	IF28	01	E ZZ CL	VI0403 002	B
COMMESSA	LOTTO	CODIFICA	DOCUMENTO	REV.	FOGLIO								
IF28	01	E ZZ CL	VI0403 002	B	22 di 161								



Figura 7-10: Combinazioni SLE: Andamento con la profondità del momento (combo SLE4 max M2).

APPALTATORE: Consorzio Soci 		ITINERARIO NAPOLI – BARI RADDOPPIO TRATTA APICE – ORSARA I LOTTO FUNZIONALE APICE – HIRPINIA					
PROGETTAZIONE: Mandataria Mandanti 							
PROGETTO ESECUTIVO RELAZIONE DI CALCOLO FONDAZIONI PILE P1, P2, P21, P22, P23 E P24		COMMESSA IF28	LOTTO 01	CODIFICA E ZZ CL	DOCUMENTO VI0403 002	REV. B	FOGLIO 23 di 161

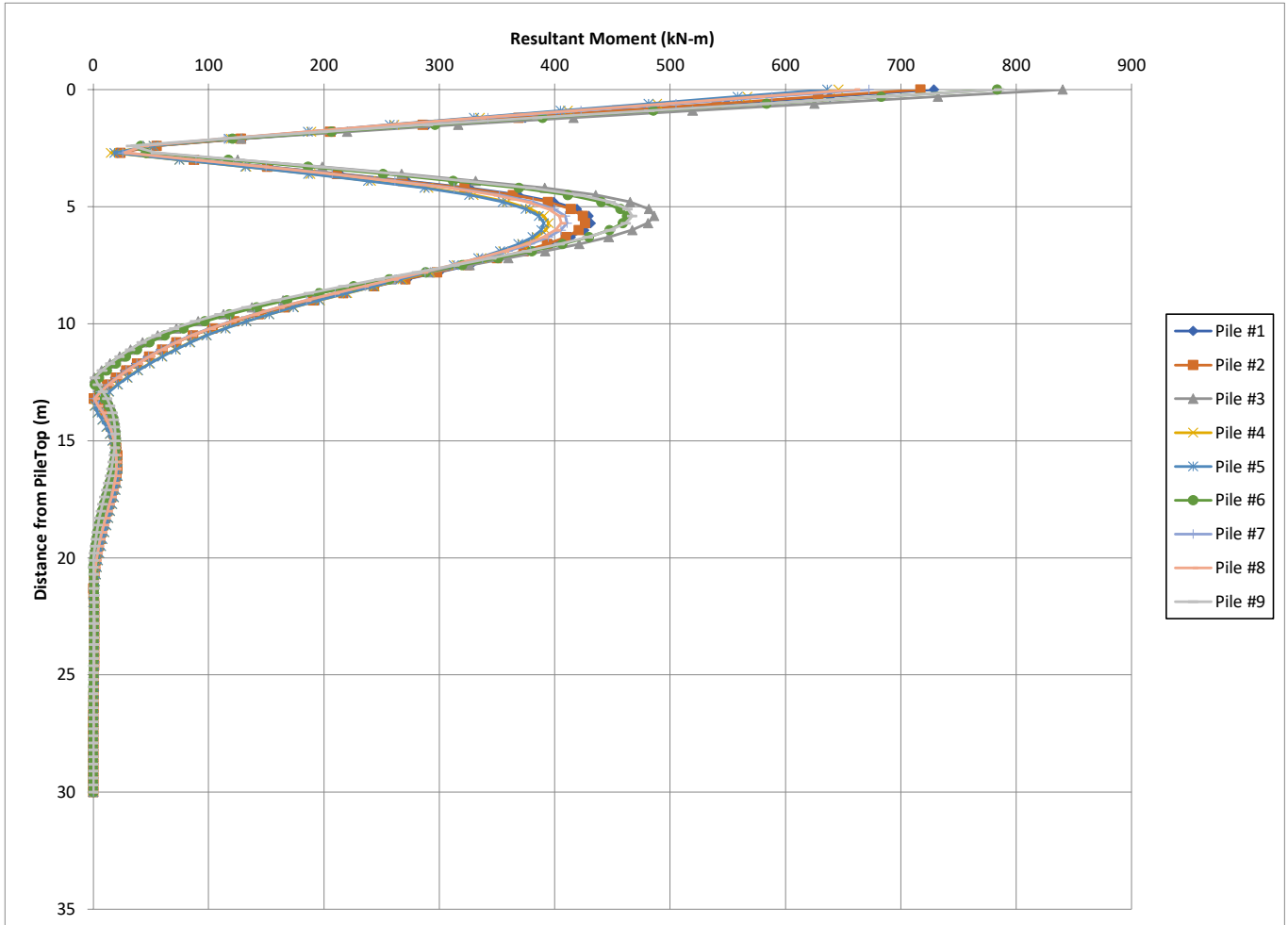

Figura 7-11: Combinazioni SLE: Andamento con la profondità del taglio (combo SLE4 max M2).

7.2.1 Spostamenti

Nella Tabella 7-10 si riportano gli spostamenti e le rotazioni ad intradosso plinto e sommità pila. Gli spostamenti orizzontali (direzione y-2) e direzione z-3) tengono già conto dell'interazione fra pali e sono quindi rappresentativi degli spostamenti orizzontali del gruppo di pali; lo spostamento verticale non tiene conto dell'effetto gruppo. Il coefficiente amplificativo del cedimento verticale per effetto gruppo E_G viene valutato in accordo a Mandolini et al. (2005) ed è riportato in Tabella 7-11.

VERTICAL , M	HORIZONTAL Y, M	HORIZONTAL Z, M	ANGLE ROT. X,RAD	ANGLE ROT. Y,RAD	ANGLE ROT. Z,RAD	Ppostamento testa pila - sle			
						H pila (m)	asse Y (mm)	asse Z (mm)	asse X (mm)
0,00169584	-0,000760934	0,000673358	2,06397E-07	7,92837E-05	7,21543E-05	9,7	-1,461	1,442	3,615
0,00130062	-0,000193873	0,000505757	-8,9281E-07	5,91274E-05	0,000019612		-0,384	1,079	2,772
0,00153473	-0,000534541	0,000601417	-5,29576E-07	8,37799E-05	5,11199E-05		-1,030	1,414	3,271
0,00156326	-0,0015077	0,000452605	5,92564E-06	0,000052928	0,000150782		-2,970	0,966	3,332

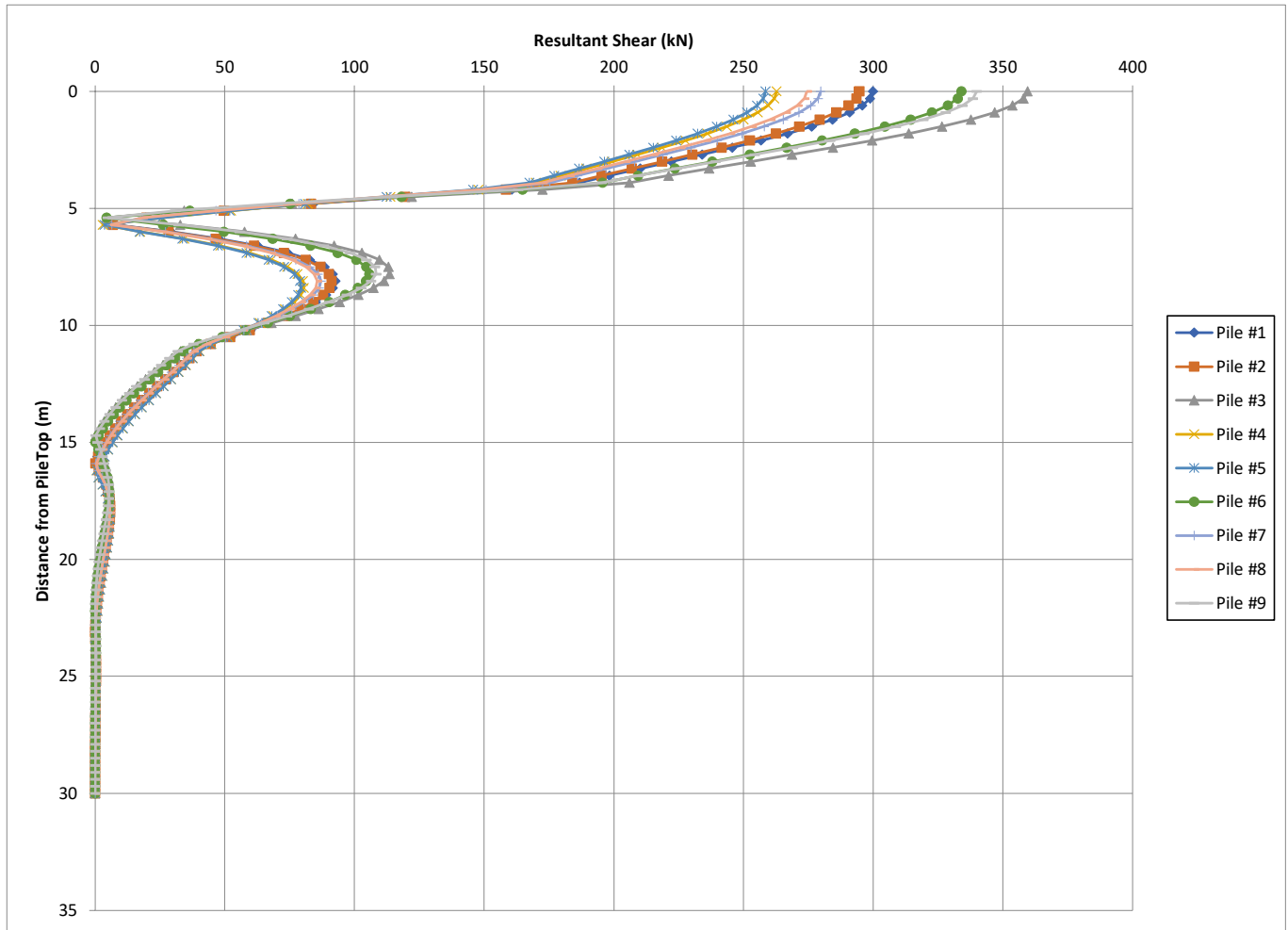
Tabella 7-10: Combinazioni SLE: spostamenti e rotazioni ad intradosso plinto.

APPALTATORE: Consorzio Soci   	ITINERARIO NAPOLI – BARI RADDOPPIO TRATTA APICE – ORSARA I LOTTO FUNZIONALE APICE – HIRPINIA					
PROGETTAZIONE: Mandataria Mandanti   						
PROGETTO ESECUTIVO RELAZIONE DI CALCOLO FONDAZIONI PILE P1, P2, P21, P22, P23 E P24	COMMESSA IF28	LOTTO 01	CODIFICA E ZZ CL	DOCUMENTO VI0403 002	REV. B	FOGLIO 24 di 161

DATI FONDAZIONE		
Larghezza plinto	12	m
Profondità plinto	12	m
Diametro palo	1,5	m
Lunghezza palo	30	m
interasse palo	4,5	m
numero pali	9	-
Coefficiente R	1,1619	-
Coefficiente RG	0,2368	-
Coeff. amplificazione cedimento del gruppo EG	2,13	-

Tabella 7-11: Coefficiente amplificativo del cedimento verticale per effetto gruppo.

7.3 SINTESI DEI RISULTATI AGLI STATI LIMITE ULTIMI STATICI (SLU)

Si riassumono nel seguito le sollecitazioni massime di sforzo assiale, taglio e momento, agenti in testa ai pali.

SLU	FOR. X, KN	FOR.H, KN	MOM, KN-M	MOM X, KN- M
	*****	*****	*****	*****
max	7143,3	525,9	1233,8	0,0
min	1745,1	128,8	284,2	-0,4

Tabella 12: Sollecitazioni allo SLU massime e minime per i pali di fondazione

Nelle seguenti figure sono diagrammati l'andamento con la profondità del momento flettente e del taglio relativi alle combinazioni in cui tali sollecitazioni risultano massime.

APPALTATORE: Consorzio Soci 		ITINERARIO NAPOLI – BARI RADDOPPIO TRATTA APICE – ORSARA I LOTTO FUNZIONALE APICE – HIRPINIA					
PROGETTAZIONE: Mandataria Mandanti 							
PROGETTO ESECUTIVO RELAZIONE DI CALCOLO FONDAZIONI PILE P1, P2, P21, P22, P23 E P24		COMMESSA IF28	LOTTO 01	CODIFICA E ZZ CL	DOCUMENTO VI0403 002	REV. B	FOGLIO 25 di 161



Figura 7-12: Combinazioni statica SLU: Andamento con la profondità del momento (combo SLU11 max F1).

APPALTATORE: Consorzio Soci 		ITINERARIO NAPOLI – BARI RADDOPPIO TRATTA APICE – ORSARA I LOTTO FUNZIONALE APICE – HIRPINIA					
PROGETTAZIONE: Mandataria Mandanti 		COMMESSA	LOTTO	CODIFICA	DOCUMENTO	REV.	FOGLIO
PROGETTO ESECUTIVO RELAZIONE DI CALCOLO FONDAZIONI PILE P1, P2, P21, P22, P23 E P24		IF28	01	E ZZ CL	VI0403 002	B	26 di 161



Figura 7-13: Combinazioni statica SLU: Andamento con la profondità del taglio (combo SLU11 max F1).

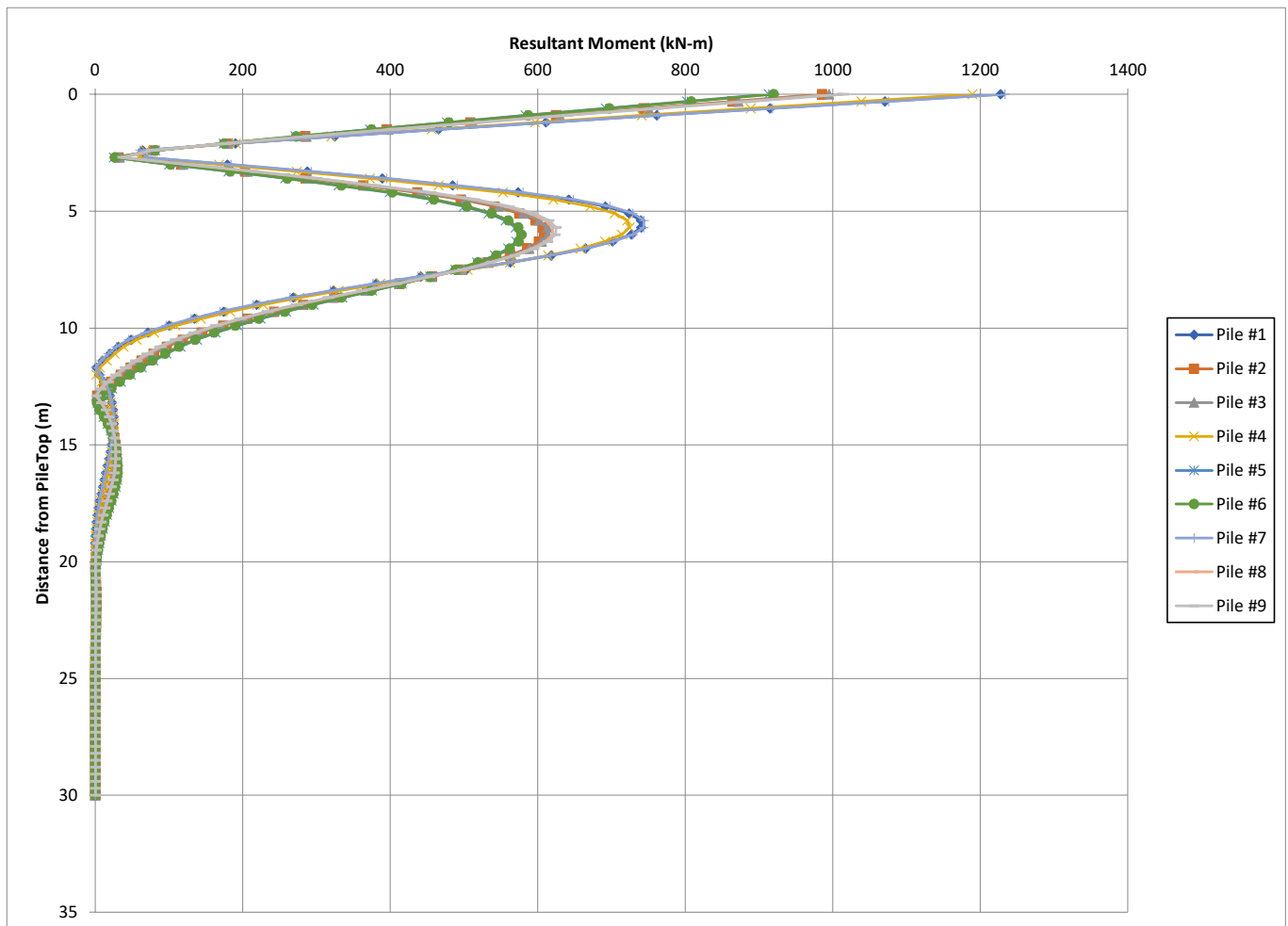

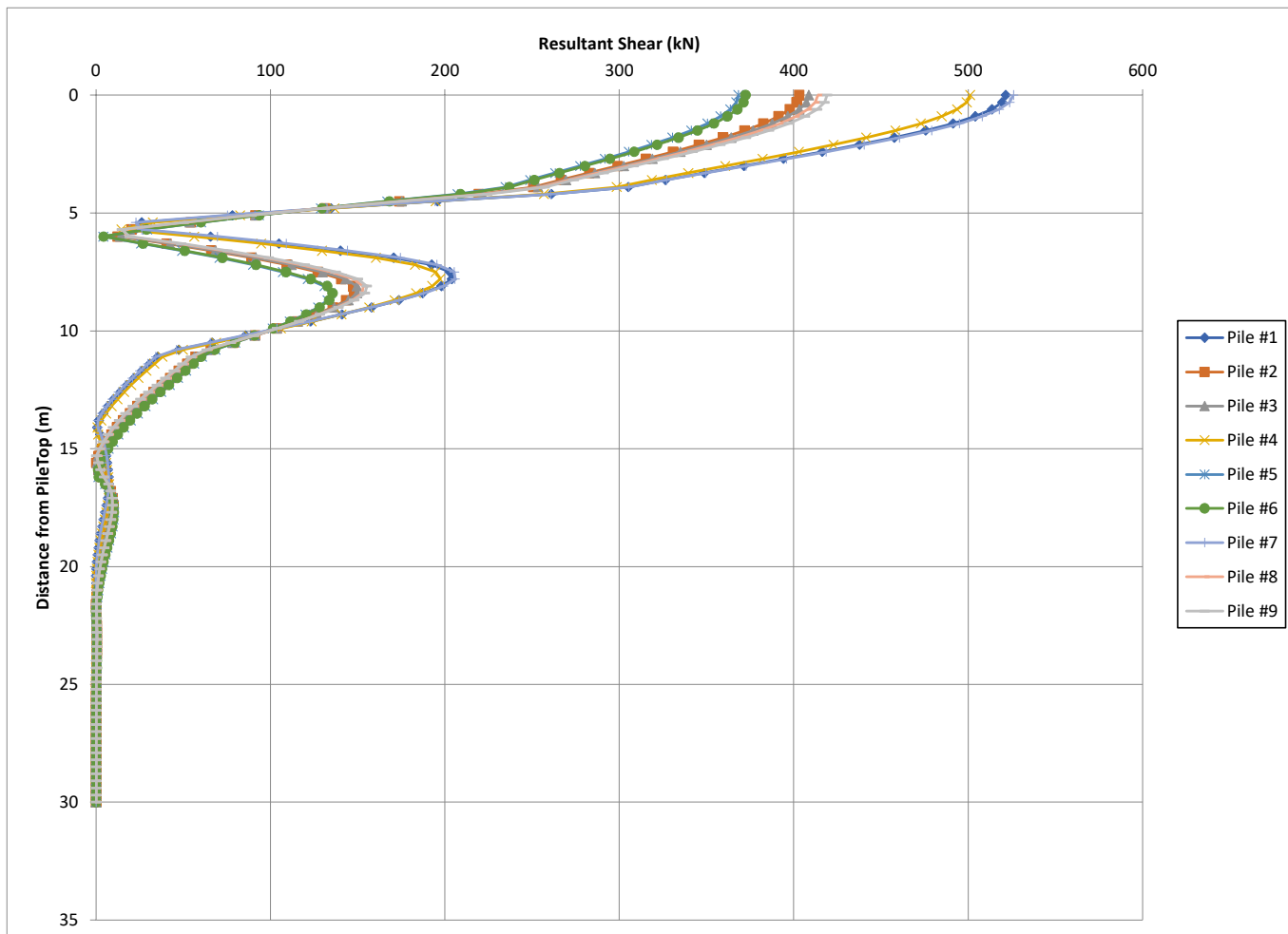

7.4 SINTESI DEI RISULTATI AGLI STATI LIMITE ULTIMI SISMICI (SLV)

Si riassumono nel seguito le sollecitazioni massime di sforzo assiale, taglio e momento, agenti in testa ai pali.

SLV	FOR. X, KN	FOR.H, KN	MOM, KN-M	MOM X, KN- M
	*****	*****	*****	*****
max	10151,0	1513,1	4057,1	6,3
min	-5173,5	375,8	960,8	-9,4

Tabella 13: Sollecitazioni allo SLV massime e minime per i pali di fondazione

Nelle seguenti figure sono diagrammati l'andamento con la profondità del momento flettente e del taglio relativi alle combinazioni in cui tali sollecitazioni risultano massime.

APPALTATORE: Consorzio Soci   	ITINERARIO NAPOLI – BARI RADDOPPIO TRATTA APICE – ORSARA I LOTTO FUNZIONALE APICE – HIRPINIA																	
PROGETTAZIONE: Mandataria Mandanti   	<table border="1" style="width: 100%; border-collapse: collapse;"> <tr> <td style="width: 16.6%;">COMMESSA</td> <td style="width: 16.6%;">LOTTO</td> <td style="width: 16.6%;">CODIFICA</td> <td style="width: 16.6%;">DOCUMENTO</td> <td style="width: 16.6%;">REV.</td> <td style="width: 16.6%;">FOGLIO</td> </tr> <tr> <td>IF28</td> <td>01</td> <td>E ZZ CL</td> <td>VI0403 002</td> <td>B</td> <td>27 di 161</td> </tr> </table>						COMMESSA	LOTTO	CODIFICA	DOCUMENTO	REV.	FOGLIO	IF28	01	E ZZ CL	VI0403 002	B	27 di 161
COMMESSA	LOTTO	CODIFICA	DOCUMENTO	REV.	FOGLIO													
IF28	01	E ZZ CL	VI0403 002	B	27 di 161													
PROGETTO ESECUTIVO RELAZIONE DI CALCOLO FONDAZIONI PILE P1, P2, P21, P22, P23 E P24																		







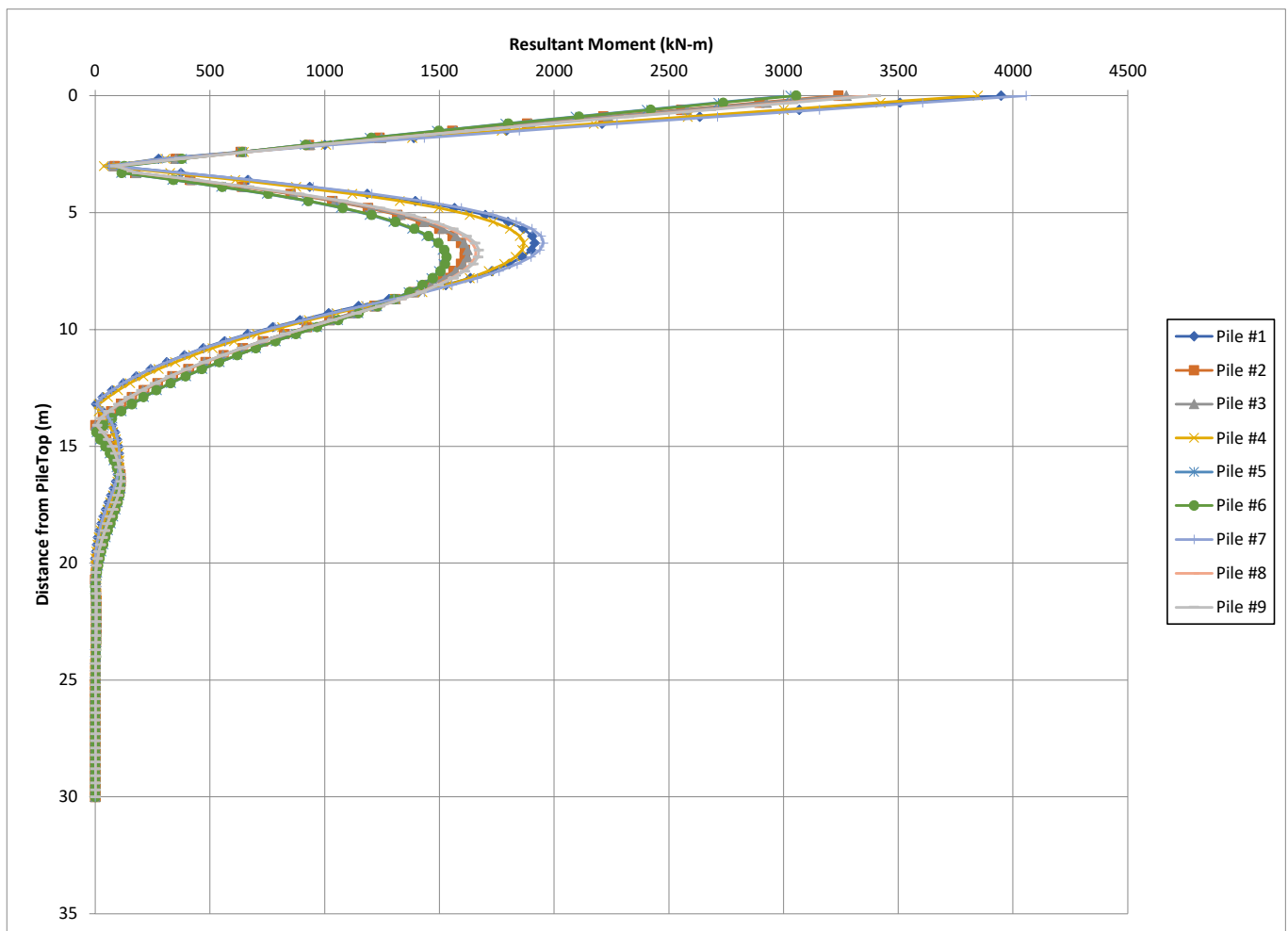

Figura 7-14: Combinazioni sismica SLV: Andamento con la profondità del momento (combo SLV1 max F1).

APPALTATORE: Consorzio Soci   		ITINERARIO NAPOLI – BARI RADDOPPIO TRATTA APICE – ORSARA I LOTTO FUNZIONALE APICE – HIRPINIA											
PROGETTAZIONE: Mandataria Mandanti   		COMMESSA IF28		LOTTO 01		CODIFICA E ZZ CL		DOCUMENTO VI0403 002		REV. B		FOGLIO 28 di 161	
PROGETTO ESECUTIVO RELAZIONE DI CALCOLO FONDAZIONI PILE P1, P2, P21, P22, P23 E P24													



Figura 7-15: Combinazioni sismica SLV: Andamento con la profondità del taglio (combo SLV8 min M1).

APPALTATORE: Consorzio  Soci  	ITINERARIO NAPOLI – BARI					
PROGETTAZIONE: Mandataria  Mandanti  	RADDOPPIO TRATTA APICE – ORSARA I LOTTO FUNZIONALE APICE – HIRPINIA					
PROGETTO ESECUTIVO RELAZIONE DI CALCOLO FONDAZIONI PILE P1, P2, P21, P22, P23 E P24	COMMESSA IF28	LOTTO 01	CODIFICA E ZZ CL	DOCUMENTO VI0403 002	REV. B	FOGLIO 29 di 161

8 VERIFICA DEI PALI DI FONDAZIONE

Nel seguito di riportano le verifiche strutturali dei pali di fondazione per la Pila P1.

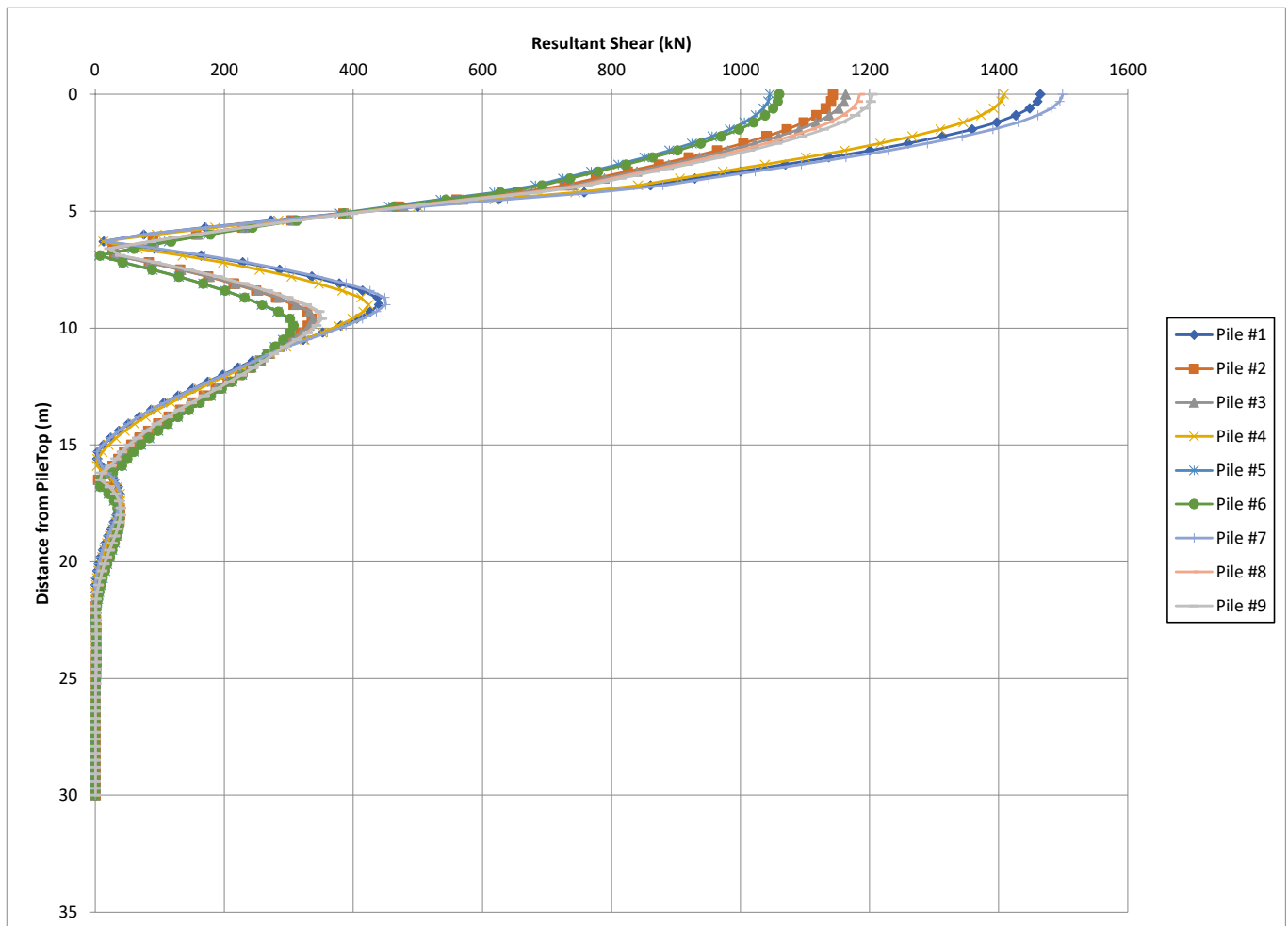
Per i pali della pila P2 si rimanda alla relazione IF1N01EZZRGMD0000 001

Le sollecitazioni massime agenti lungo il fusto del palo sono riassunte nella **Tabella 14**.

LOAD CASE :	PILE GROUP	FOR. X, KN	FOR. Y, KN	FOR. Z, KN	MOM X, KN- M	MOM Y, KN- M	MOM Z, KN- M	FOR.H, KN	MOM, KN-M
*****	*****	*****	*****	*****	*****	*****	*****		
SLV-1.00	7	8765,7	1456,5	-352,92	4,7323	920,51	3951,3	1498,65	4057,11
SLV-7.00	7	-5173,5	-407,02	1075,4	-9,3929	-2936,6	-1151,4	1149,85	3154,26
SLV-8.00	7	10151	528,08	-1418	-4,1005	3768,4	1410	1513,14	4023,55

LOAD CASE :	PILE GROUP	FOR. X, KN	FOR. Y, KN	FOR. Z, KN	MOM X, KN- M	MOM Y, KN- M	MOM Z, KN- M	FOR.H, KN	MOM, KN-M
*****	*****	*****	*****	*****	*****	*****	*****		
SLE-4.00	3					-181,08	-820,47		840,21
SLE-4.00	7	1436,9	-	-	-	-	-		-

Tabella 14: Sollecitazioni massime agenti nel palo

Nel seguito si riportano le verifiche strutturali del palo trivellato di diametro $\varnothing = 1500\text{mm}$ in cls – C25/30 e lunghezza L 30m. Per le verifiche si considerano le sollecitazioni risultanti. Sono risultate più severe le verifiche in presenza di trazione.

In riferimento all'andamento dei momenti lungo il fusto del palo- Momenti Figura 7-14 e Taglio Figura 7-15- sono state previste n. 3 ordini di armature principali:

1. L'armatura massima:
 - o ferri correnti: corona esterna n.26 $\varnothing 30$;
 - o ferri correnti: corona interna n.13 $\varnothing 30$;
 - o staffatura: spirale $\varnothing 14$ passo 10.

2. L'armatura media:
 - o ferri correnti: corona esterna n.26 $\varnothing 26$;
 - o ferri correnti: corona interna n.13 $\varnothing 26$;
 - o staffatura: spirale $\varnothing 14$ passo 20.

3. L'armatura minima:
 - o ferri correnti: corona esterna n.26 $\varnothing 24$;
 - o staffatura: spirale $\varnothing 14$ passo 20.

Le verifiche strutturali del palo sono soddisfatte; di seguito le schede di calcolo.

APPALTATORE: Consorzio HirpiniaAV Soci salini impregilo ASTALDI	ITINERARIO NAPOLI – BARI RADDOPPIO TRATTA APICE – ORSARA I LOTTO FUNZIONALE APICE – HIRPINIA
PROGETTAZIONE: Mandataria ROKSOJL Mandanti NETENGINEERING Alpina	
PROGETTO ESECUTIVO RELAZIONE DI CALCOLO FONDAZIONI PILE P1, P2, P21, P22, P23 E P24	
COMMESSA IF28 LOTTO 01 CODIFICA E ZZ CL DOCUMENTO VI0403 002 REV. B FOGLIO 30 di 161	

geometria				
sezione trasversale				
D	c	d	passo	interferro
[cm]	[cm]	[cm]	[cm]	[cm]
150	6,0	141,1	16,0	13,0
armatura longitudinale				
nbarre	φ	r _i	A _{sl}	c _i
	[mm]	[cm]	[cm ²]	[cm]
26	30	66,10	183,78	8,90
13	30	59,10	91,89	15,90
armatura a taglio				
Tipo	φ	p	A _{sw}	
	[mm]	[cm]	[cm ²]	
spirale	14	10	3,08	

sollecitazioni e risultati	
SLE	SLU
M _{Ek} 840,2 [kNm]	M _{Ed} 3154,3 [kNm]
N _{Ek} -1436,9 [kN]	N _{Ed} 5173,5 [kN]
momento di cracking	V _{Ed} 1513,1 [kN]
M _{cr} 1238,4 [kNm]	presso-flessione
quota asse neutro	M _{Rd} 3336,4 [kNm]
y _n 83,54 [cm]	FS 1,06
tensioni e fessure	taglio
σ _{c,min} -3,0 [MPa]	V _{Rdc} -43,0 [kN]
σ _{s,min} -40,2 [MPa]	predisporre armatura a taglio
σ _{s,max} 30,9 [MPa]	V _{Rds} 1926,5 [kN]
k ₂ 0,5	V _{Rdmax} 4480,7 [kN]
ε _{sm-ε_{cm}} - [%]	θ 30,0 [°]
S _{r,max} - [cm]	sezione ductile
w _k - [mm]	a _l 92,1 [cm]

materiali			
calcestruzzo		acciaio	
R _{ck}	30 [MPa]	f _{yk}	450 [MPa]
f _{ck}	24,9 [MPa]	γ _s	1,15
γ _c	1,5	f _{yd}	391,3 [MPa]
α _{cc}	0,85	E _s	200000 [MPa]
f _{cd}	14,1 [MPa]	ε _{uk}	10 [‰]
v	0,5	valori limite	
ε _{c2}	2,0 [‰]	0,55 f _{ck}	13,7 [MPa]
ε _{cu2}	3,5 [‰]	0,75 f _{yk}	337,5 [MPa]
α _e	15,0	w _{k,lim}	0,2 [mm]
k _t	0,6		
k ₁	0,8		
k ₃	3,4		
k ₄	0,425		



Tabella 8-15: Verifica del palo D=1500mm; armatura massima

APPALTATORE: Consorzio HirpiniaAV Soci salini impregilo ASTALDI	ITINERARIO NAPOLI – BARI RADDOPPIO TRATTA APICE – ORSARA I LOTTO FUNZIONALE APICE – HIRPINIA					
PROGETTAZIONE: Mandataria ROKSOJL Mandanti NETENGINEERING Alpina						
PROGETTO ESECUTIVO RELAZIONE DI CALCOLO FONDAZIONI PILE P1, P2, P21, P22, P23 E P24	COMMESSA IF28	LOTTO 01	CODIFICA E ZZ CL	DOCUMENTO VI0403 002	REV. B	FOGLIO 31 di 161

geometria				
sezione trasversale				
D	c	d	passo	interferro
[cm]	[cm]	[cm]	[cm]	[cm]
150	6,0	141,3	16,0	13,4
armatura longitudinale				
n _{barre}	φ	r _i	A _{sl}	c _i
	[mm]	[cm]	[cm ²]	[cm]
26	26	66,30	138,04	8,70
13	26	59,70	69,02	15,30
armatura a taglio				
Tipo	φ	ρ	A _{sw}	
	[mm]	[cm]	[cm ²]	
spirale	14	20	3,08	

sollecitazioni e risultati	
SLE	SLU
M _{Ek} 840,2 [kNm]	M _{Ed} 1610,7 [kNm]
N _{Ek} -1436,9 [kN]	N _{Ed} 5173,5 [kN]
	V _{Ed} 405,6 [kN]
momento di cracking	presso-flessione
M _{cr} 1162,3 [kNm]	M _{Rd} 1826,0 [kNm]
quota asse neutro	FS 1,13
y _n 79,79 [cm]	taglio
tensioni e fessure	V _{Rdc} -105,7 [kN]
σ _{c,min} -3,4 [MPa]	predisporre armatura a taglio
σ _{s,min} -44,6 [MPa]	
σ _{s,max} 38,5 [MPa]	
	V _{Rds} 963,8 [kN]
k ₂ 0,5	V _{Rdmax} 4487,1 [kN]
ε _{sm-ε_{cm}} - [%]	θ 30,0 [°]
S _{r,max} - [cm]	sezione duttile
W _k - [mm]	a _i 90,2 [cm]

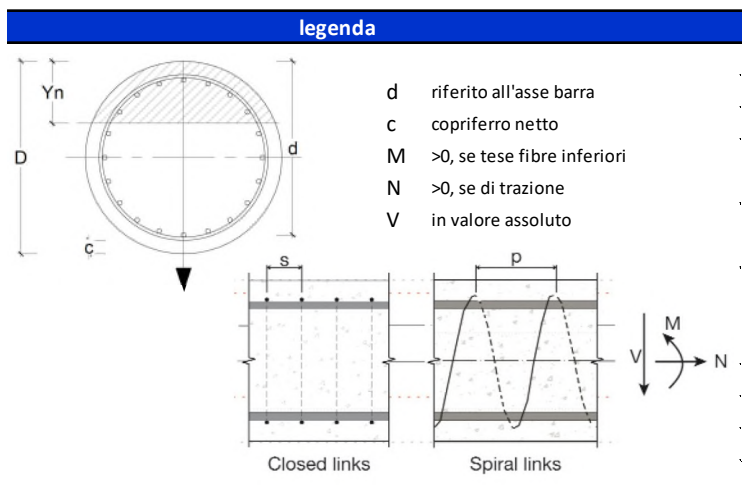
materiali			
calcestruzzo		acciaio	
R _{ck}	30 [MPa]	f _{yk}	450 [MPa]
f _{ck}	24,9 [MPa]	γ _s	1,15
γ _c	1,5	f _{yd}	391,3 [MPa]
α _{cc}	0,85	E _s	200000 [MPa]
f _{cd}	14,1 [MPa]	ε _{uk}	10 [‰]
v	0,5		
ε _{c2}	2,0 [‰]		
ε _{cu2}	3,5 [‰]		
α _e	15,0		
k _t	0,6		
k ₁	0,8		
k ₃	3,4		
k ₄	0,425		
		valori limite	
		0,55 f _{ck}	13,7 [MPa]
		0,75 f _{yk}	337,5 [MPa]
		W _{k,lim}	0,2 [mm]



Tabella 8-16: Verifica del palo D=1500mm; armatura media

APPALTATORE: Consorzio HirpiniaAV Soci salini impregilo ASTALDI	ITINERARIO NAPOLI – BARI RADDOPPIO TRATTA APICE – ORSARA I LOTTO FUNZIONALE APICE – HIRPINIA
PROGETTAZIONE: Mandataria SOJL Mandanti NETENGINEERING Alpina	
PROGETTO ESECUTIVO RELAZIONE DI CALCOLO FONDAZIONI PILE P1, P2, P21, P22, P23 E P24	
COMMESSA IF28 LOTTO 01 CODIFICA E ZZ CL DOCUMENTO VI0403 002 REV. B FOGLIO 32 di 161	

geometria				
sezione trasversale				
D	c	d	passo	interferro
[cm]	[cm]	[cm]	[cm]	[cm]
150	6,0	141,4	16,0	13,6
armatura longitudinale				
n _{barre}	φ	r _i	A _{sl}	c _i
	[mm]	[cm]	[cm ²]	[cm]
26	24	66,40	117,62	8,60
61,20				
armatura a taglio				
Tipo	φ	p	A _{sw}	
	[mm]	[cm]	[cm ²]	
spirale	14	20	3,08	

sollecitazioni e risultati	
SLE	SLU
M _{Ek} 840,2 [kNm]	M _{Ed} 65,0 [kNm]
N _{Ek} -1436,9 [kN]	N _{Ed} 2085,8 [kN]
momento di cracking	V _{Ed} 405,6 [kN]
M _{cr} 1125,5 [kNm]	presso-flessione
quota asse neutro	M _{Rd} 1565,7 [kNm]
y _n 76,46 [cm]	FS 24,09
tensioni e fessure	taglio
σ _{c,min} -3,7 [MPa]	V _{Rdc} 223,6 [kN]
σ _{s,min} -48,8 [MPa]	predisporre armatura a taglio
σ _{s,max} 46,7 [MPa]	
	V _{Rds} 964,5 [kN]
k ₂ 0,5	V _{Rdmax} 4490,3 [kN]
ε _{sm-ε_{cm}} - [%]	θ 30,0 [°]
S _{r,max} - [cm]	sezione duttile
W _k - [mm]	a _i 90,3 [cm]

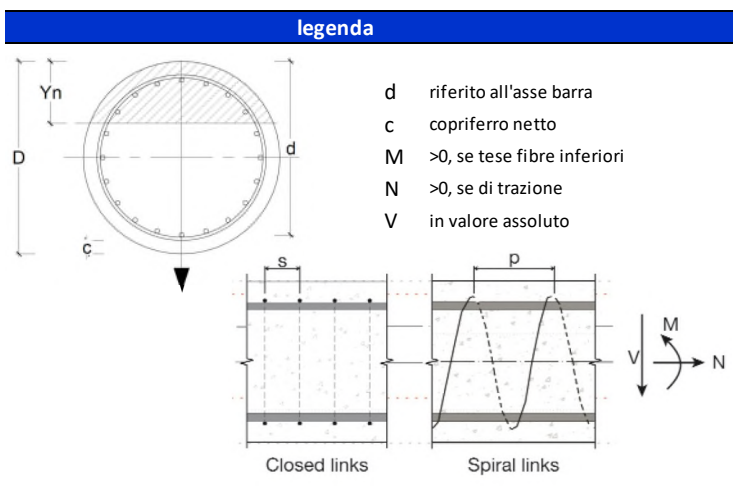
materiali			
calcestruzzo		acciaio	
R _{ck}	30 [MPa]	f _{yk}	450 [MPa]
f _{ck}	24,9 [MPa]	γ _s	1,15
γ _c	1,5	f _{yd}	391,3 [MPa]
α _{cc}	0,85	E _s	200000 [MPa]
f _{cd}	14,1 [MPa]	ε _{uk}	10 [‰]
v	0,5		
ε _{c2}	2,0 [‰]		
ε _{cu2}	3,5 [‰]		
α _e	15,0		
k _t	0,6		
k ₁	0,8		
k ₃	3,4		
k ₄	0,425		
		valori limite	
		0,55 f _{ck}	13,7 [MPa]
		0,75 f _{yk}	337,5 [MPa]
		W _{k,lim}	0,2 [mm]



Tabella 8-17: Verifica del palo D=1500mm; armatura minima

APPALTATORE: Consorzio  Soci  		ITINERARIO NAPOLI – BARI RADDOPPIO TRATTA APICE – ORSARA I LOTTO FUNZIONALE APICE – HIRPINIA					
PROGETTAZIONE: Mandataria  Mandanti  							
PROGETTO ESECUTIVO RELAZIONE DI CALCOLO FONDAZIONI PILE P1, P2, P21, P22, P23 E P24						COMMESSA IF28	LOTTO 01

8.1.1 Schemi armatura e incidenza del palo

Nelle Figura 8-1 e Figura 8-2 sono schematizzate le armature correnti e le armature di taglio. Nella Tabella 8-18 l'incidenza di armatura valutata con una percentuale di incremento pari al 10% dovuta a ganci di sollevamento, armature di confezionamento, legatura, ecc.; si considera una incidenza di progetto pari a 150kg/m³.

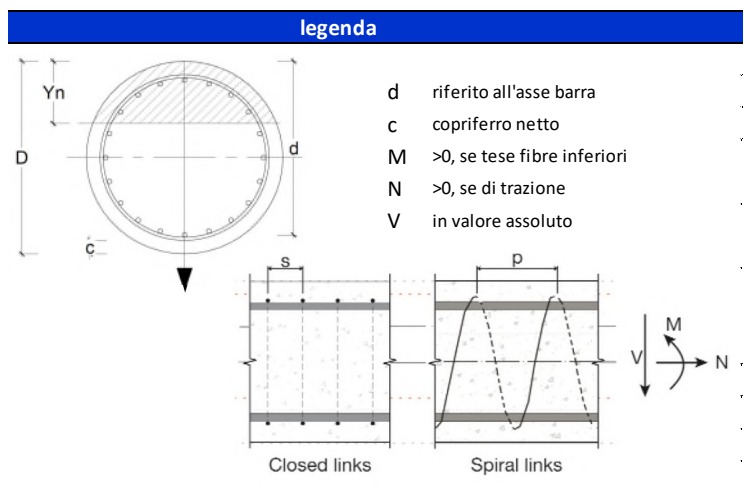
Tabella ferri							
ARMATURA PALO LUNGH. = 30 m							
POS.	N.	DIAM.	LUNGH. (cm)	P.U.	LUNGH. TOT. (cm)	PESO (kg)	
1	26	30	1200	5,549	31200	1731	
2	13	30	1200	5,549	15600	866	
3	26	26	1200	4,168	31200	1300	
4	13	26	680	4,168	8840	368	
5	26	24	1140	3,551	29640	1053	
6	1	14	43784	1,208	43784,32134	529	
7	1	14	21480	1,208	21480,36752	260	
8	1	14	20192	1,208	20191,54547	244	
9	20	40	450	9,864	9000	888	
Kg						7238	

AREA PALO (m²) **1,77**
 LUNGH. PALO (m) **30,00**
 VOLUME (m³) **52,99**

INCIDENZA DI CALCOLO (kg/m³) **136,6**
 Incremento percentuale % (*) **10**
 INCIDENZA DI PROGETTO (kg/m³) **~150**

(*) incremento in % dovuto a ganci di sollevamento, armature di confezionamento, legature, ecc.

Tabella 8-18 Incidenza armatura

APPALTATORE: Consorzio HirpiniaAV Soci salini impreglio ASTALDI		ITINERARIO NAPOLI – BARI					
PROGETTAZIONE: Mandataria ROKSOJL Mandanti NETENGINEERING Alpina		RADDOPPIO TRATTA APICE – ORSARA I LOTTO FUNZIONALE APICE – HIRPINIA					
PROGETTO ESECUTIVO RELAZIONE DI CALCOLO FONDAZIONI PILE P1, P2, P21, P22, P23 E P24		COMMESSA IF28	LOTTO 01	CODIFICA E ZZ CL	DOCUMENTO VI0403 002	REV. B	FOGLIO 34 di 161

VI04 P1

PALO D=1500mm

L=30m

Copriferro 6cm

Staffa irrigidimento Ø40



Figura 8-1: VI04 P22 Schema armatura gabbie

APPALTATORE: Consorzio HirpiniaAV Soci salini impregilo ASTALDI		ITINERARIO NAPOLI – BARI					
PROGETTAZIONE: Mandataria ROKSOJL Mandanti NETENGINEERING Alpina		RADDOPPIO TRATTA APICE – ORSARA I LOTTO FUNZIONALE APICE – HIRPINIA					
PROGETTO ESECUTIVO RELAZIONE DI CALCOLO FONDAZIONI PILE P1, P2, P21, P22, P23 E P24		COMMESSA IF28	LOTTO 01	CODIFICA E ZZ CL	DOCUMENTO VI0403 002	REV. B	FOGLIO 35 di 161

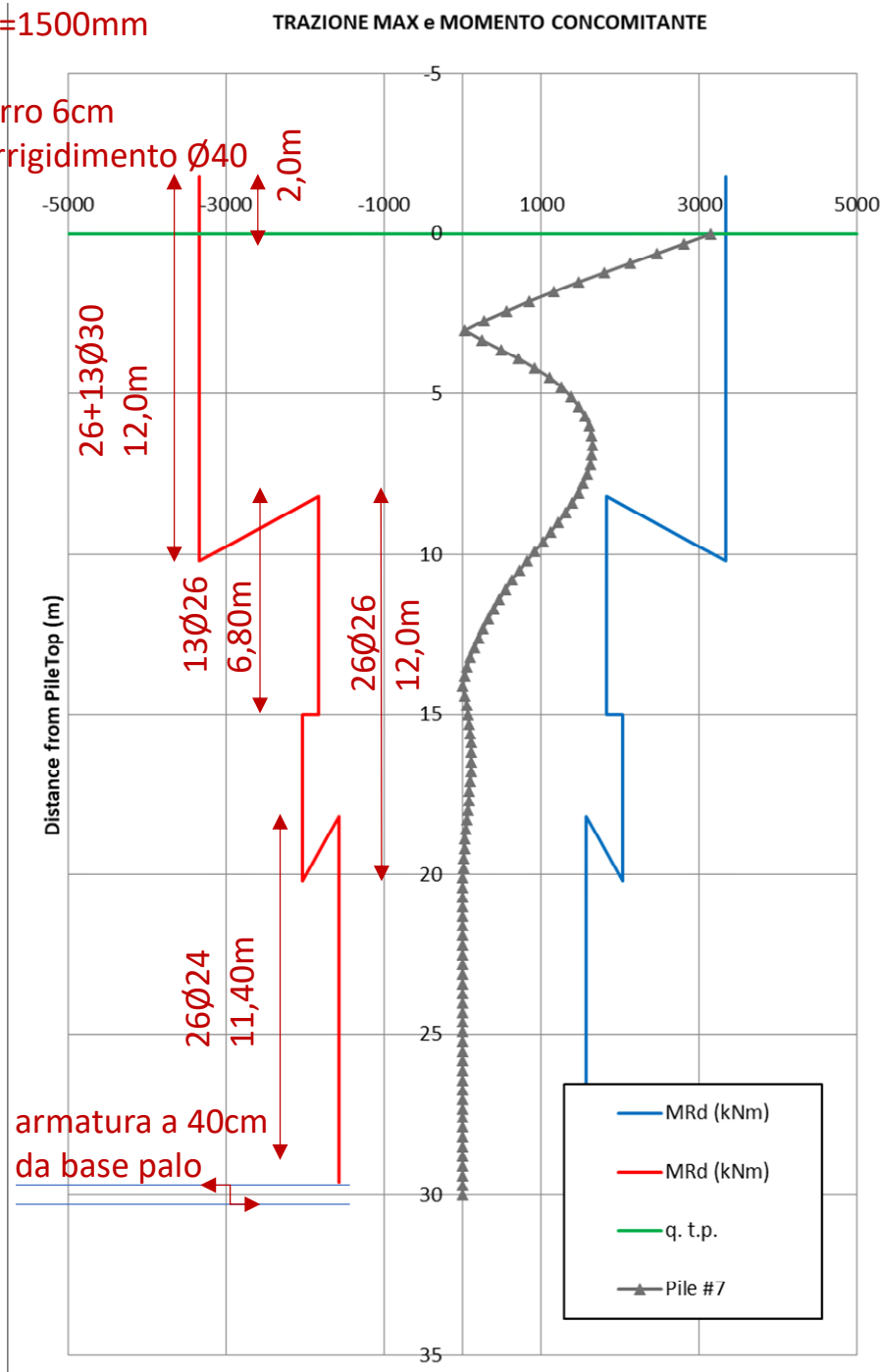

Figura 8-2: VI04 P22 Schema armatura a taglio

APPALTATORE: Consorzio Soci   	ITINERARIO NAPOLI – BARI RADDOPPIO TRATTA APICE – ORSARA I LOTTO FUNZIONALE APICE – HIRPINIA												
PROGETTAZIONE: Mandataria Mandanti   													
PROGETTO ESECUTIVO RELAZIONE DI CALCOLO FONDAZIONI PILE P1, P2, P21, P22, P23 E P24	<table border="1" style="width: 100%; border-collapse: collapse;"> <tr> <td style="width: 25%;">COMMESSA</td> <td style="width: 15%;">LOTTO</td> <td style="width: 25%;">CODIFICA</td> <td style="width: 20%;">DOCUMENTO</td> <td style="width: 10%;">REV.</td> <td style="width: 5%;">FOGLIO</td> </tr> <tr> <td>IF28</td> <td>01</td> <td>E ZZ CL</td> <td>VI0403 002</td> <td>B</td> <td>36 di 161</td> </tr> </table>	COMMESSA	LOTTO	CODIFICA	DOCUMENTO	REV.	FOGLIO	IF28	01	E ZZ CL	VI0403 002	B	36 di 161
COMMESSA	LOTTO	CODIFICA	DOCUMENTO	REV.	FOGLIO								
IF28	01	E ZZ CL	VI0403 002	B	36 di 161								

9 VERIFICHE ALLO SLU DI TIPO GEOTECNICO

9.1 VERIFICA DI CAPACITÀ PORTANTE DEL PALO SINGOLO

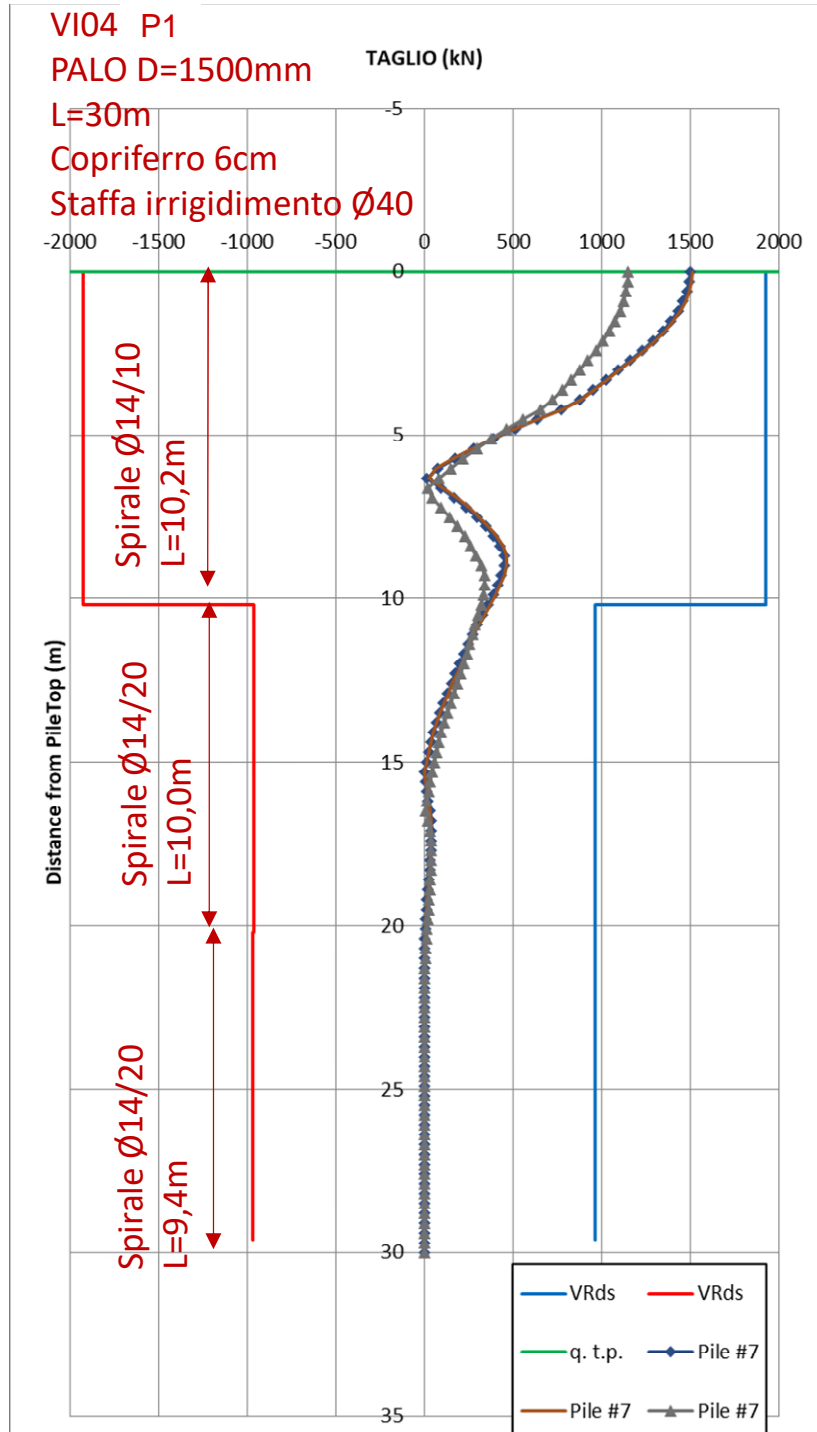
La verifica di capacità portante verticale per il singolo palo è stata condotta in accordo ai criteri esposti nel documento di cui al ref. 2).

Di seguito si riporta, per i pali di fondazione di lunghezza $L = 30$ m, la capacità portante a compressione ($R_{c,d}$) e a trazione ($R_{t,d}$), secondo l'approccio 2 ($A1+M1+R3$).

I carichi assiali massimi agenti sui pali sono riassunti nella seguente tabella:

Massima compressione, N_{dc} , max [kN]	10151,0 (SLV)
Massima trazione, N_{dt} , max [kN]	-5173,5 (SLV)

Tabella 19: Combinazione SLU e SLV: Sollecitazioni massime di compressione e trazione

Si verifica inoltre che lo sforzo assiale massimo in esercizio (Tabella 19) sia inferiore della resistenza laterale di calcolo ($R_{c,s,k}$) divisa per un fattore pari a 1.25.

Massima compressione, N_{dcSLE} , max [kN]	5164,8 (SLE)
--	--------------

Tabella 20: Combinazione SLE: Sollecitazione massima di compressione

In Tabella 9-21 si riporta, per i pali di lunghezza 30.0 m, la capacità portante a compressione ($R_{c,d}$) e a trazione ($R_{t,d}$) del palo isolato secondo l'Approccio 2 ($A1+M1+R3$).

Combinazione SLU A1+M1+R3 (metodo AGI)							Comb. SLU A1+M1+R3 (metodo AGI)				
L_{palo}	$Q_{l-c,k}$	$Q_{b-c,k}$	$Q_{l-c,d}$	$Q_{b-c,d}$	ΔW_{palo}	$Q_{c,d}$	L_{palo}	$Q_{l-t,k}$	$Q_{l-t,d}$	ΔW_{palo}	$Q_{t,d}$
m	kN	kN	kN	kN	kN	kN	m	kN	kN	kN	kN
30,0	13563,5	7598,7	7862,88	3752,46	1033,78	10581,55	30,0	13563,5	7233,85	795,22	8029,06

Tabella 9-21: Capacità portante a compressione e a trazione dei pali di fondazione secondo l'Approccio 2 ($A1+M1+R3$).

APPALTATORE: Consorzio HirpiniaAV Soci salini impregilo ASTALDI	ITINERARIO NAPOLI – BARI RADDOPPIO TRATTA APICE – ORSARA I LOTTO FUNZIONALE APICE – HIRPINIA					
PROGETTAZIONE: Mandataria ROKSOJL Mandanti NETENGINEERING Alpina						
PROGETTO ESECUTIVO RELAZIONE DI CALCOLO FONDAZIONI PILE P1, P2, P21, P22, P23 E P24						

9.1.1 Capacità portante verticale del palo singolo

Stratigrafia e parametri geotecnici

Dati di input		
Diametro Palo	1.5	m
Sovraccarico efficace	92,3	kPa
HW da testa palo	1	m
γ acqua	10	kN/m ³
Δz palo da p.c. originario	4,5	m
N° diametri per qb	4	(-)
L palo fuori terra	0	(m)
Peso calcestruzzo	25	kN/m ³
Pressione max sul cls.	11.34	MPa

Caratteristiche del terreno													
Profondità (m)		Strato	Terreno	γ_{tot}	Nspt		c_u (kPa)		Δz	ϕ°		Nq	
da	a	No.	(S,SL,G,A)	kN/m ³	da	a	da	a	(m)	da	a	da	a
0,0	4,00	1	S	19,0					1,00	29	29	9,1	9,1
4,0	11,00	2	A	20,5			115	115	1,00				
11,0	16,00	3	S	20,5					1,00	32	32	11,95	11,95
16,0	25,50	4	A	20,5			220	220	1,00				
25,5	35,50	5	S	20,5					1,00	32	32	11,95	11,95
35,5	50,0	6	A	20,5			300	300	1,00				

Verticali di indagine	ξ_3	ξ_4
5	1.50	1.34

Scelta di ξ	ξ
3	1.5







APPALTATORE: Consorzio Soci   	ITINERARIO NAPOLI – BARI RADDOPPIO TRATTA APICE – ORSARA I LOTTO FUNZIONALE APICE – HIRPINIA												
PROGETTAZIONE: Mandataria Mandanti   													
PROGETTO ESECUTIVO RELAZIONE DI CALCOLO FONDAZIONI PILE P1, P2, P21, P22, P23 E P24	<table border="0" style="width: 100%;"> <tr> <td>COMMESSA</td> <td>LOTTO</td> <td>CODIFICA</td> <td>DOCUMENTO</td> <td>REV.</td> <td>FOGLIO</td> </tr> <tr> <td>IF28</td> <td>01</td> <td>E ZZ CL</td> <td>VI0403 002</td> <td>B</td> <td>38 di 161</td> </tr> </table>	COMMESSA	LOTTO	CODIFICA	DOCUMENTO	REV.	FOGLIO	IF28	01	E ZZ CL	VI0403 002	B	38 di 161
COMMESSA	LOTTO	CODIFICA	DOCUMENTO	REV.	FOGLIO								
IF28	01	E ZZ CL	VI0403 002	B	38 di 161								

Combinazione SLE (metodo AGI)						
L palo	τ_s calcolo	q_{ub} calcolo	$R_{c,s,k}$	$R_{c,b,k}$	ΔW palo	$Q_{c,s,k}/1.25$
m	kPa	kPa	kN	kN	kN	kN
1,0	33,8	314,5	159,5	555,8	26,5	101,1
2,0	38,5	629,0	340,9	1111,6	53,0	219,7
3,0	41,5	943,6	536,4	1667,4	79,5	349,6
4,0	44,5	1258,1	746,0	2223,2	106,0	490,8
4,0	46,0	1258,1	746,0	2223,2	106,0	490,8
5,0	80,4	1512,3	1125,0	2672,4	132,5	767,5
6,0	80,4	1766,5	1504,0	3121,6	159,0	1044,2
7,0	80,4	2020,7	1883,1	3570,8	185,6	1320,9
8,0	80,4	2274,9	2262,1	4020,0	212,1	1597,6
9,0	80,4	2274,9	2641,1	4020,0	238,6	1874,3
10,0	80,4	2274,9	3020,1	4020,0	265,1	2151,0
11,0	80,4	2274,9	3399,1	4020,0	291,6	2427,7
11,0	80,4	2274,9	3399,1	4020,0	291,6	2427,7
12,0	81,4	2495,6	3782,5	4410,1	318,1	2707,9
13,0	85,3	2716,3	4184,4	4800,1	344,6	3002,9
14,0	89,2	2872,6	4604,9	5076,4	371,1	3312,8
15,0	93,2	2963,9	5044,0	5237,6	397,6	3637,6
16,0	97,1	3055,2	5501,6	5398,9	424,1	3977,1
16,0	99,1	3055,2	5501,6	5398,9	424,1	3977,1
17,0	111,2	3146,4	6025,8	5560,2	450,6	4370,0
18,0	111,2	3146,4	6550,0	5560,2	477,1	4762,9
19,0	111,2	3146,4	7074,2	5560,2	503,6	5155,7
20,0	111,2	3146,4	7598,4	5560,2	530,1	5548,6
21,0	111,2	3146,4	8122,7	5560,2	556,7	5941,5
22,0	111,2	3146,4	8646,9	5560,2	583,2	6334,3
23,0	111,2	3146,4	9171,1	5560,2	609,7	6727,2
24,0	111,2	3146,4	9695,3	5560,2	636,2	7120,1
25,0	111,2	3146,4	10219,5	5560,2	662,7	7513,0
25,5	111,2	3146,4	10481,7	5560,2	675,9	7709,4
25,5	111,2	3146,4	10481,7	5560,2	675,9	7709,4
26,0	137,5	3274,6	10805,5	5786,7	689,2	7955,2
27,0	140,4	3531,0	11467,2	6239,7	715,7	8458,1
28,0	144,3	3787,3	12147,4	6692,7	742,2	8975,7
29,0	148,3	4043,7	12846,2	7145,7	768,7	9508,2
30,0	152,2	4300,0	13563,5	7598,7	795,2	10055,6
31,0	156,2	4300,0	14299,3	7598,7	821,7	10617,7
32,0	160,1	4300,0	15053,7	7598,7	848,2	11194,8
33,0	164,0	4143,6	15826,7	7322,3	874,7	11786,6
34,0	168,0	3987,1	16618,2	7045,8	901,2	12393,3
35,0	171,9	3830,7	17428,3	6769,4	927,8	13014,9
35,5	174,9	3752,5	17840,3	6631,1	941,0	13331,2
35,5	175,8	3752,5	17840,3	6631,1	941,0	13331,2
36,0	129,9	3674,2	18146,4	6492,9	954,3	13562,8
37,0	129,9	3674,2	18758,5	6492,9	980,8	14026,0
38,0	129,9	3674,2	19370,7	6492,9	1007,3	14489,3
39,0	129,9	3674,2	19982,8	6492,9	1033,8	14952,5
40,0	129,9	3674,2	20595,0	6492,9	1060,3	15415,7

APPALTATORE: Consorzio Soci   	ITINERARIO NAPOLI – BARI RADDOPPIO TRATTA APICE – ORSARA I LOTTO FUNZIONALE APICE – HIRPINIA				
PROGETTAZIONE: Mandataria Mandanti   					
PROGETTO ESECUTIVO RELAZIONE DI CALCOLO FONDAZIONI PILE P1, P2, P21, P22, P23 E P24					
COMMESSA IF28	LOTTO 01	CODIFICA E ZZ CL	DOCUMENTO V10403 002	REV. B	FOGLIO 39 di 161

Combinazione SLU A1+M1+R3 (metodo AGI)						
L palo	Q l-c,k	Q b-c,k	Q l-c,d	Q b-c,d	ΔW palo	Q _{c,d}
m	kN	kN	kN	kN	kN	kN
1,0	159,5	555,8	92,45	274,47	34,46	332,46
2,0	340,9	1111,6	197,61	548,94	68,92	677,63
3,0	536,4	1667,4	310,96	823,41	103,38	1030,99
4,0	746,0	2223,2	432,48	1097,88	137,84	1392,52
4,0	746,0	2223,2	432,48	1097,88	137,84	1392,52
5,0	1125,0	2672,4	652,19	1319,71	172,30	1799,60
6,0	1504,0	3121,6	871,91	1541,53	206,76	2206,69
7,0	1883,1	3570,8	1091,63	1763,36	241,22	2613,77
8,0	2262,1	4020,0	1311,34	1985,19	275,67	3020,86
9,0	2641,1	4020,0	1531,06	1985,19	310,13	3206,12
10,0	3020,1	4020,0	1750,77	1985,19	344,59	3391,37
11,0	3399,1	4020,0	1970,49	1985,19	379,05	3576,63
11,0	3399,1	4020,0	1970,49	1985,19	379,05	3576,63
12,0	3782,5	4410,1	2192,75	2177,82	413,51	3957,05
13,0	4184,4	4800,1	2425,76	2370,44	447,97	4348,22
14,0	4604,9	5076,4	2669,52	2506,84	482,43	4693,93
15,0	5044,0	5237,6	2924,04	2586,49	516,89	4993,63
16,0	5501,6	5398,9	3189,31	2666,13	551,35	5304,09
16,0	5501,6	5398,9	3189,31	2666,13	551,35	5304,09
17,0	6025,8	5560,2	3493,21	2745,78	585,81	5653,17
18,0	6550,0	5560,2	3797,10	2745,78	620,27	5922,61
19,0	7074,2	5560,2	4101,00	2745,78	654,73	6192,04
20,0	7598,4	5560,2	4404,89	2745,78	689,19	6461,48
21,0	8122,7	5560,2	4708,79	2745,78	723,65	6730,92
22,0	8646,9	5560,2	5012,68	2745,78	758,11	7000,35
23,0	9171,1	5560,2	5316,58	2745,78	792,56	7269,79
24,0	9695,3	5560,2	5620,48	2745,78	827,02	7539,23
25,0	10219,5	5560,2	5924,37	2745,78	861,48	7808,66
25,5	10481,7	5560,2	6076,32	2745,78	878,71	7943,38
25,5	10481,7	5560,2	6076,32	2745,78	878,71	7943,38
26,0	10805,5	5786,7	6264,07	2857,63	895,94	8225,76
27,0	11467,2	6239,7	6647,64	3081,34	930,40	8798,57
28,0	12147,4	6692,7	7041,97	3305,04	964,86	9382,15
29,0	12846,2	7145,7	7447,04	3528,75	999,32	9976,47
30,0	13563,5	7598,7	7862,88	3752,46	1033,78	10581,55
31,0	14299,3	7598,7	8289,46	3752,46	1068,24	10973,68
32,0	15053,7	7598,7	8726,80	3752,46	1102,70	11376,56
33,0	15826,7	7322,3	9174,90	3615,94	1137,16	11653,68
34,0	16618,2	7045,8	9633,75	3479,42	1171,62	11941,55
35,0	17428,3	6769,4	10103,35	3342,90	1206,08	12240,17
35,5	17840,3	6631,1	10342,19	3274,63	1223,31	12393,52
35,5	17840,3	6631,1	10342,19	3274,63	1223,31	12393,52
36,0	18146,4	6492,9	10519,63	3206,37	1240,54	12485,46
37,0	18758,5	6492,9	10874,50	3206,37	1275,00	12805,88
38,0	19370,7	6492,9	11229,37	3206,37	1309,46	13126,29
39,0	19982,8	6492,9	11584,25	3206,37	1343,91	13446,71
40,0	20595,0	6492,9	11939,12	3206,37	1378,37	13767,12

Comb. SLU A1+M1+R3 (metodo AGI)				
L palo	Q l-t,k	Q l-t,d	ΔW palo	Q _{t,d}
m	kN	kN	kN	kN
1,0	159,5	85,05	26,51	111,56
2,0	340,9	181,80	53,01	234,82
3,0	536,4	286,08	79,52	365,60
4,0	746,0	397,88	106,03	503,91
4,0	746,0	397,88	106,03	503,91
5,0	1125,0	600,02	132,54	732,55
6,0	1504,0	802,16	159,04	961,20
7,0	1883,1	1004,30	185,55	1189,85
8,0	2262,1	1206,43	212,06	1418,49
9,0	2641,1	1408,57	238,56	1647,14
10,0	3020,1	1610,71	265,07	1875,78
11,0	3399,1	1812,85	291,58	2104,43
11,0	3399,1	1812,85	291,58	2104,43
12,0	3782,5	2017,33	318,09	2335,41
13,0	4184,4	2231,69	344,59	2576,29
14,0	4604,9	2455,96	371,10	2827,06
15,0	5044,0	2690,11	397,61	3087,72
16,0	5501,6	2934,17	424,12	3358,28
16,0	5501,6	2934,17	424,12	3358,28
17,0	6025,8	3213,75	450,62	3664,37
18,0	6550,0	3493,33	477,13	3970,46
19,0	7074,2	3772,92	503,64	4276,55
20,0	7598,4	4052,50	530,14	4582,65
21,0	8122,7	4332,09	556,65	4888,74
22,0	8646,9	4611,67	583,16	5194,83
23,0	9171,1	4891,25	609,67	5500,92
24,0	9695,3	5170,84	636,17	5807,01
25,0	10219,5	5450,42	662,68	6113,10
25,5	10481,7	5590,21	675,93	6266,15
25,5	10481,7	5590,21	675,93	6266,15
26,0	10805,5	5762,95	689,19	6452,13
27,0	11467,2	6115,83	715,69	6831,52
28,0	12147,4	6478,61	742,20	7220,81
29,0	12846,2	6851,28	768,71	7619,99
30,0	13563,5	7233,85	795,22	8029,06
31,0	14299,3	7626,31	821,72	8448,03
32,0	15053,7	8028,66	848,23	8876,89
33,0	15826,7	8440,91	874,74	9315,64
34,0	16618,2	8863,05	901,24	9764,29
35,0	17428,3	9295,09	927,75	10222,84
35,5	17840,3	9514,81	941,01	10455,82
35,5	17840,3	9514,81	941,01	10455,82
36,0	18146,4	9678,06	954,26	10632,31
37,0	18758,5	10004,54	980,77	10985,31
38,0	19370,7	10331,02	1007,27	11338,30
39,0	19982,8	10657,51	1033,78	11691,29
40,0	20595,0	10983,99	1060,29	12044,28

APPALTATORE: Consorzio Soci   	ITINERARIO NAPOLI – BARI					
PROGETTAZIONE: Mandataria Mandanti   	RADDOPPIO TRATTA APICE – ORSARA I LOTTO FUNZIONALE APICE – HIRPINIA					
PROGETTO ESECUTIVO RELAZIONE DI CALCOLO FONDAZIONI PILE P1, P2, P21, P22, P23 E P24	COMMESSA IF28	LOTTO 01	CODIFICA E ZZ CL	DOCUMENTO VI0403 002	REV. B	FOGLIO 40 di 161

VI04 - pila P22
 Capacità portante A1+M1+R3
 Palo D=1500mm





Figura 9-1: Capacità portante del palo singolo

APPALTATORE: Consorzio  Soci  	ITINERARIO NAPOLI – BARI RADDOPPIO TRATTA APICE – ORSARA I LOTTO FUNZIONALE APICE – HIRPINIA					
PROGETTAZIONE: Mandataria  Mandanti  						
PROGETTO ESECUTIVO RELAZIONE DI CALCOLO FONDAZIONI PILE P1, P2, P21, P22, P23 E P24	COMMESSA IF28	LOTTO 01	CODIFICA E ZZ CL	DOCUMENTO VI0403 002	REV. B	FOGLIO 41 di 161

9.1.1 Verifica di capacità portante verticale del gruppo di pali

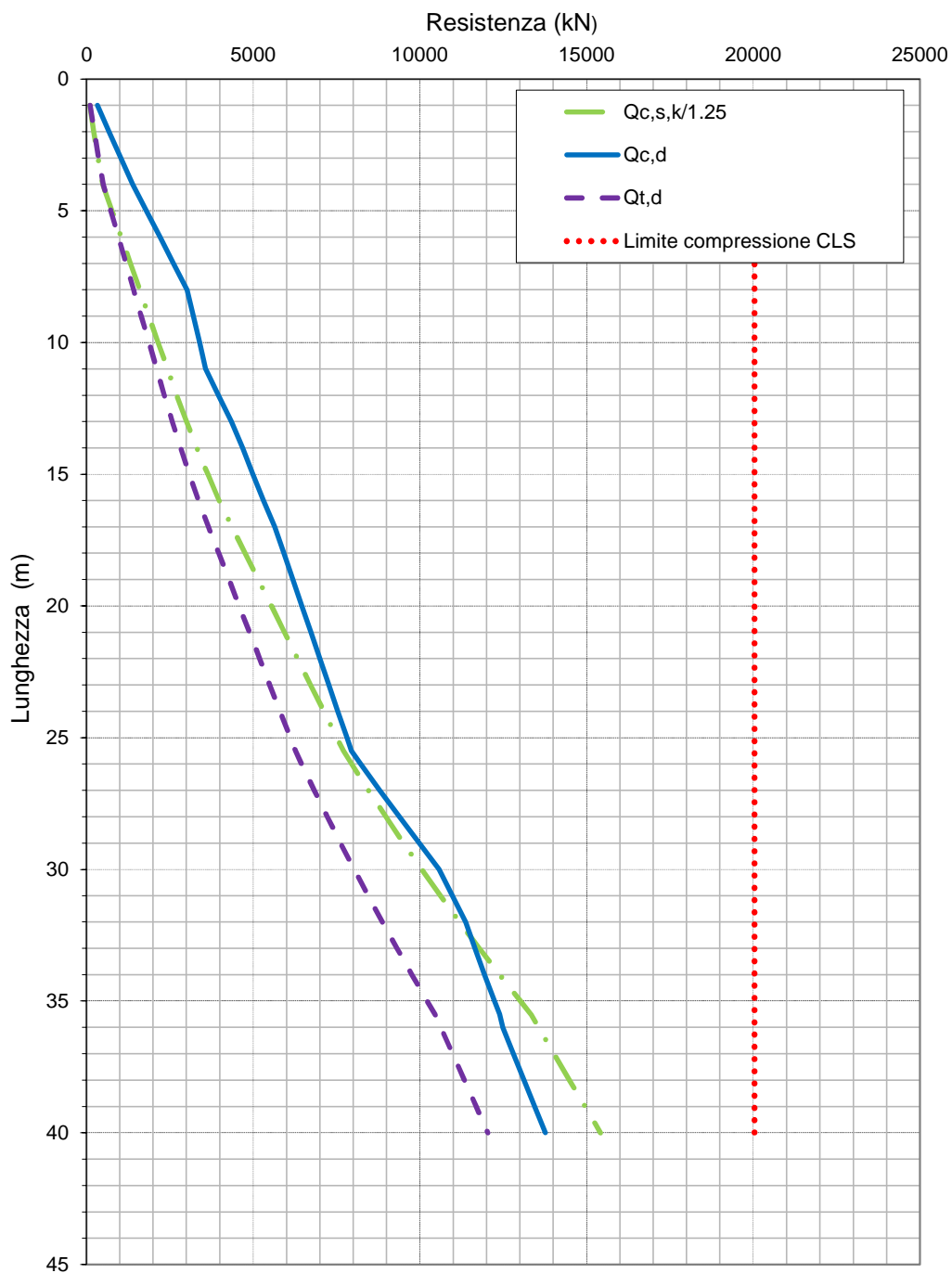
La verifica di capacità portante verticale del blocco è stata condotta in accordo ai criteri descritti nel documento di cui al Ref. 2) §7.1.

Nella seguente tabella si riporta la capacità portante del blocco valutata secondo l'Approccio 2 (A1+M1+R3).

CAPACITA' PORTANTE VERTICALE GRUPPI DI PALI				
B	10,5		m	larghezza pozzo
L	10,5		m	lunghezza pozzo
D	30		m	profondità pozzo
i	4,5		m	interasse pali
n°	9			numero dei pali
γ_R cap.port.	2,3			coefficiente sicurezza globale per capacità portante
ξ_3	1,5			fattore di correlazione in base alle verticali indagate
γ_s	1,15			coefficiente di resistenza laterale
γ_b	1,35			coefficiente di resistenza base
$Cu_{b,calc}$	300		kPa	coesione non drenata di calcolo, base
$Cu_{b,d}$	148		kPa	coesione non drenata di progetto, base
$Cu_{s,i}$	200	300	kPa	coesione strato i
d_i	30	0	m	altezza strato i-esimo
$Cu_{s,calc}$	200		kPa	coesione non drenata di calcolo, laterale
$Cu_{s,d}$	116		kPa	coesione non drenata di progetto, laterale
A_s	1260		m ²	area laterale
A_b	110		m ²	area base
S_{block}	1			fattore forma
N_c	5,14			fattore di portanza alla base
$R_{block,c,d}$	100029		kN	resistenza di progetto
Valutazione alternativa dell'Area di Base				
$A_{b,diafr}$	15,90		m ²	area di impronta dei soli pali o pannelli
$R_{punz,c,d}$	68783		kN	Resistenza di progetto con area di base
CAPACITA' PORTANTE VERTICALE GRUPPI DI PALI				
Verifica:				
N slu, max	44090		kN	
FSblock	2,27		ok	
FSpunz	1,56		ok	

Tabella 22: Capacità portante del blocco (Approccio 2: A1+M1+R3)

APPALTATORE: Consorzio HirpiniaAV Soci salini impregilo ASTALDI	ITINERARIO NAPOLI – BARI					
PROGETTAZIONE: Mandataria SOJL Mandanti NETENGINEERING Alpina	RADDOPPIO TRATTA APICE – ORSARA I LOTTO FUNZIONALE APICE – HIRPINIA					
PROGETTO ESECUTIVO RELAZIONE DI CALCOLO FONDAZIONI PILE P1, P2, P21, P22, P23 E P24	COMMESSA IF28	LOTTO 01	CODIFICA E ZZ CL	DOCUMENTO VI0403 002	REV. B	FOGLIO 42 di 161

9.1.2 Verifica di capacità portante orizzontale del gruppo di pali

La verifica di capacità portante orizzontale del gruppo di pali è stata condotta con i criteri descritti nel documento di cui al Ref. 2) §6.2, con i metodi basati sulle curve p-y.

Considerata la presenza di successioni stratigrafiche abbastanza articolate, con contrasti di rigidezza anche marcati e caratteristiche diverse delle varie unità geotecniche, si è fatto uso del programma FEM non lineare LPile, considerando negli strati di terreno curve p-y non lineari, definibili lungo il fuso del palo, e opportunamente ridotte secondo il coefficiente parziale $\xi \times \gamma_T$.

Si ricava una curva "pushover" del palo singolo: incrementando progressivamente il carico orizzontale applicato alla testa del palo, fino al raggiungimento del collasso, vale a dire della completa plasticizzazione del terreno. Tale plasticizzazione si rende "visibile" attraverso il cambiamento del comportamento deformativo del palo stesso, al raggiungimento del "plateau" di resistenza.

Nella seguente Figura 9-2 è illustrata la curva push-over ottenuta per il palo in oggetto, con il vincolo di invastro, al crescere dell'azione H applicata alla testa dello stesso.

Il taglio massimo agente è pari a $T_{longSLV} = 1513,14$ kN.

La verifica a capacità portante orizzontale risulta soddisfatta, poiché il carico limite $H_{lim} = 4067.0$ kN risulta superiore al valore di progetto.



Figura 9-2: Analisi push-over palo

APPALTATORE: <u>Consorzio</u> <u>Soci</u> HIRPINIA AV SALINI IMPREGILO S.P.A. ASTALDI S.P.A	ITINERARIO NAPOLI – BARI RADDOPPIO TRATTA APICE – ORSARA I LOTTO FUNZIONALE APICE – HIRPINIA					
PROGETTAZIONE: <u>Mandatario</u> <u>Mandanti</u> ROCKSOIL S.P.A NET ENGINEERING S.P.A. ALPINA S.P.A.						
PROGETTO ESECUTIVO RELAZIONE DI CALCOLO FONDAZIONI PILE P1, P2, P21, P22, P23 E P24	COMMESSA IF28	LOTTO 01	CODIFICA E ZZ CL	DOCUMENTO VI0403 002	REV. B	FOGLIO 43 di 161

10 DIMENSIONAMENTO E VERIFICA DEL PLINTO DI FONDAZIONE [P1 P21 P22 P23 P24]

10.1 DESCRIZIONE DEL MODELLO

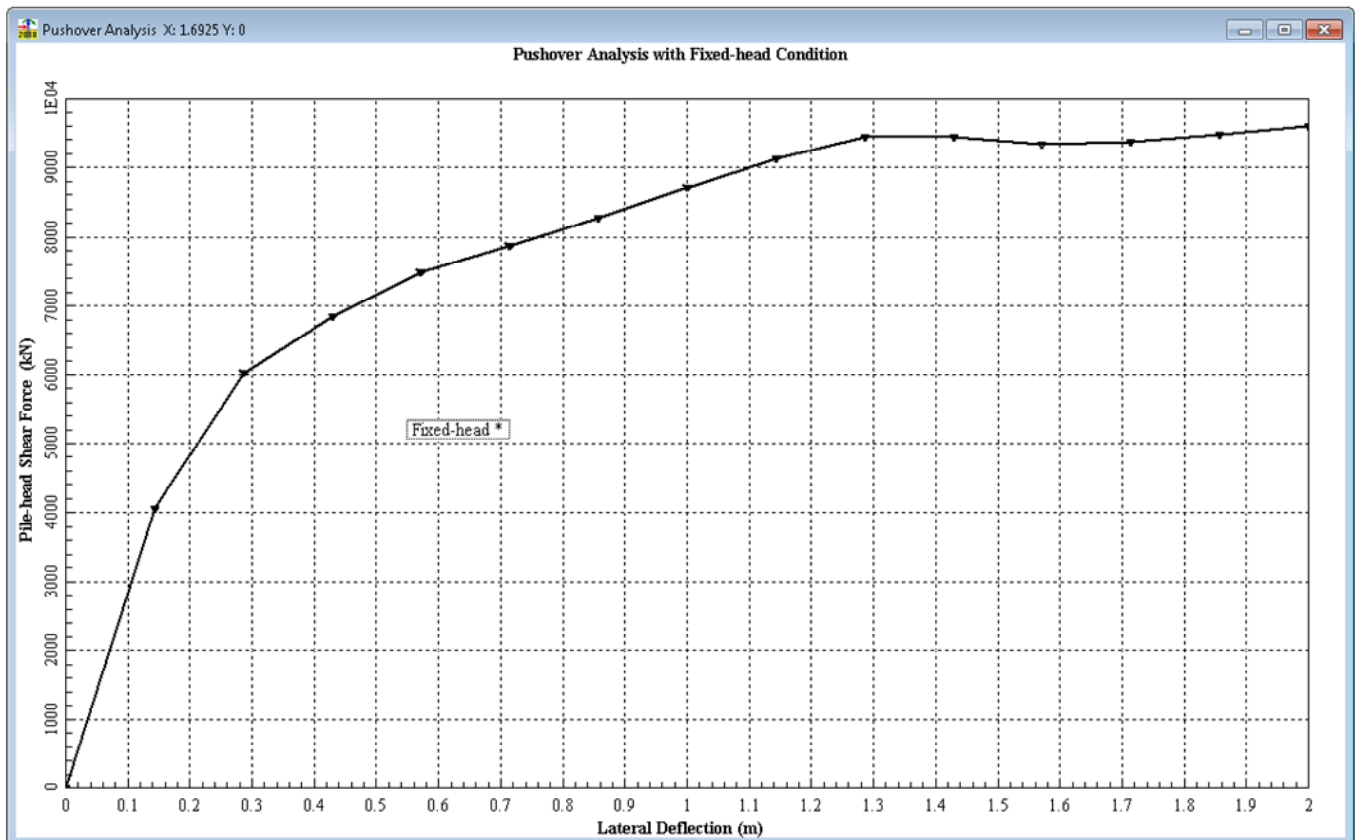
La platea di fondazione ha le seguenti dimensioni 12 m x 12 m x 2,5 m, con un ricoprimento minimo di 1,0 m; la platea presenta 9 pali.

Il dimensionamento a flessione e taglio del plinto di fondazione viene fatta a filo della pila, in modo da valutare le massime sollecitazioni, **Figura 10.1**.



Figura 10.1 Pianta del plinto

La platea di fondazione è stata modellata mediante il software SAP2000, con elementi shell.

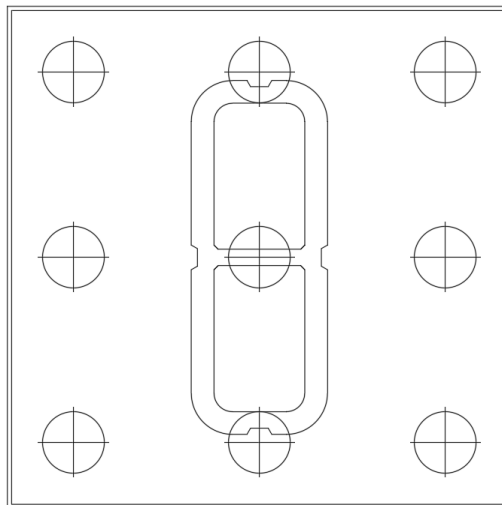

Figura 10.2 Modello numerico

APPALTATORE: Consorzio Soci 		ITINERARIO NAPOLI – BARI RADDOPPIO TRATTA APICE – ORSARA I LOTTO FUNZIONALE APICE – HIRPINIA					
PROGETTAZIONE: Mandataria Mandanti 							
PROGETTO ESECUTIVO RELAZIONE DI CALCOLO FONDAZIONI PILE P1, P2, P21, P22, P23 E P24		COMMESSA IF28	LOTTO 01	CODIFICA E ZZ CL	DOCUMENTO VI0403 002	REV. B	FOGLIO 44 di 161

A partire dalle azioni interne delle fondazioni profonde, definiti precedentemente, è stato possibile caricare la platea in esame, considerando il carico concentrato proveniente dalle differenti combinazioni per ogni palo nel proprio baricentro.

La platea è stata vincolata in corrispondenza del fusto pila attraverso dei vincoli traslazionali che non interrompono la continuità del momento, **Figura 10.3**.

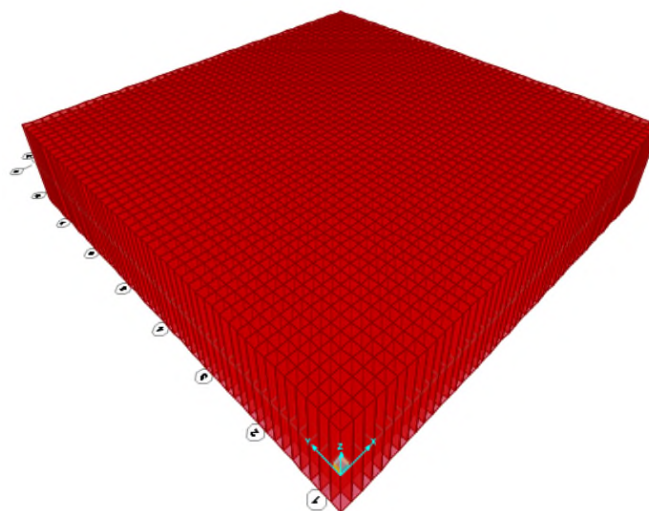

Figura 10.3 Modello numerico con le condizioni al contorno

10.1.1 Combinazioni e carichi

Le combinazioni introdotte nel modello numerico ad elementi finiti sono caratterizzate da non avere coefficienti di amplificazione per i vari Stati Limite, in quanto gli scarichi dei pali considerano già tale amplificazione.

Sono state considerate:

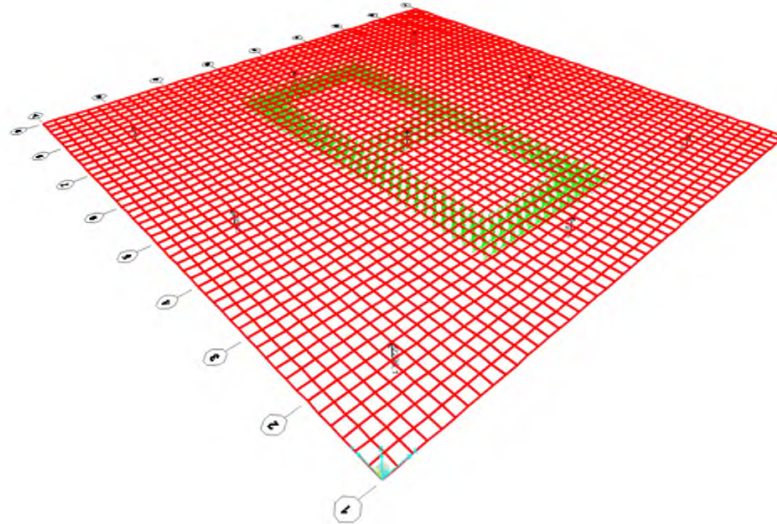
- 10 Combinazioni SLV, stato limite di salvaguardia della vita;
- 6 Combinazioni SLU, stato limite ultimo;
- 4 Combinazioni SLE-R, stato limite di esercizio caratteristico.

Gli scarichi sui pali sono stati quelli determinati attraverso il software Group come definito al paragrafo 7.1.

Ai carichi sopra citati, viene aggiunto il carico distribuito dato dal terreno di ricoprimento minimo, considerando tale carico permanente non strutturale.

Di seguito sono esplicitati i carichi sui pali nelle combinazioni:

SLE- Caratteristica					
Point load	Combination	F [kN]	Point load	Combination	F [kN]
Palo1	Pali SLE1	3637,9	Palo1	Pali SLE3	3544,1
Palo2	Pali SLE1	4297,2	Palo2	Pali SLE3	4011,1
Palo3	Pali SLE1	4956,4	Palo3	Pali SLE3	4478,2
Palo4	Pali SLE1	2913,5	Palo4	Pali SLE3	2778,6
Palo5	Pali SLE1	3572,8	Palo5	Pali SLE3	3245,7

APPALTATORE: Consorzio  Soci  		ITINERARIO NAPOLI – BARI RADDOPPIO TRATTA APICE – ORSARA I LOTTO FUNZIONALE APICE – HIRPINIA					
PROGETTAZIONE: Mandataria  Mandanti  							
PROGETTO ESECUTIVO RELAZIONE DI CALCOLO FONDAZIONI PILE P1, P2, P21, P22, P23 E P24		COMMESSA IF28	LOTTO 01	CODIFICA E ZZ CL	DOCUMENTO VI0403 002	REV. B	FOGLIO 45 di 161

Palo6	Pali SLE1	4232	Palo6	Pali SLE3	3712,7
Palo7	Pali SLE1	2189,1	Palo7	Pali SLE3	2013,1
Palo8	Pali SLE1	2848,4	Palo8	Pali SLE3	2480,2
Palo9	Pali SLE1	3507,6	Palo9	Pali SLE3	2947,3
Palo1	Pali SLE2	3131,4	Palo1	Pali SLE4	2409,5
Palo2	Pali SLE2	3310,6	Palo2	Pali SLE4	3787,2
Palo3	Pali SLE2	3489,8	Palo3	Pali SLE4	5164,8
Palo4	Pali SLE2	2591,1	Palo4	Pali SLE4	1926
Palo5	Pali SLE2	2770,3	Palo5	Pali SLE4	3303,6
Palo6	Pali SLE2	2949,5	Palo6	Pali SLE4	4681,3
Palo7	Pali SLE2	2050,9	Palo7	Pali SLE4	1436,9
Palo8	Pali SLE2	2230,1	Palo8	Pali SLE4	2820
Palo9	Pali SLE2	2409,3	Palo9	Pali SLE4	4197,7

SLU					
Point load	Combination	F [kN]	Point load	Combination	F [kN]
Palo1	Pali SLU1	5813,1	Palo1	Pali SLU4	2626,8
Palo2	Pali SLU1	3779,1	Palo2	Pali SLU4	2359,4
Palo3	Pali SLU1	1745,1	Palo3	Pali SLU4	2092,1
Palo4	Pali SLU1	6559,8	Palo4	Pali SLU4	3433,7
Palo5	Pali SLU1	4525,8	Palo5	Pali SLU4	3166,3
Palo6	Pali SLU1	2491,8	Palo6	Pali SLU4	2899
Palo7	Pali SLU1	7143,3	Palo7	Pali SLU4	4240,6
Palo8	Pali SLU1	5272,5	Palo8	Pali SLU4	3973,2
Palo9	Pali SLU1	3238,5	Palo9	Pali SLU4	3705,8
Palo1	Pali SLU2	4455,7	Palo1	Pali SLU5	3983,2
Palo2	Pali SLU2	3834,7	Palo2	Pali SLU5	3300,9
Palo3	Pali SLU2	3213,7	Palo3	Pali SLU5	2618,5
Palo4	Pali SLU2	5519,9	Palo4	Pali SLU5	5106,9
Palo5	Pali SLU2	4898,9	Palo5	Pali SLU5	4424,6
Palo6	Pali SLU2	4277,9	Palo6	Pali SLU5	3742,2
Palo7	Pali SLU2	6584,1	Palo7	Pali SLU5	6230,6
Palo8	Pali SLU2	5963,1	Palo8	Pali SLU5	5548,3
Palo9	Pali SLU2	5342,1	Palo9	Pali SLU5	4865,9
Palo1	Pali SLU3	4803,1	Palo1	Pali SLU6	5813,1
Palo2	Pali SLU3	3831,1	Palo2	Pali SLU6	3779,1
Palo3	Pali SLU3	2859,1	Palo3	Pali SLU6	1745,1
Palo4	Pali SLU3	5876,7	Palo4	Pali SLU6	6559,8
Palo5	Pali SLU3	4904,7	Palo5	Pali SLU6	4525,8
Palo6	Pali SLU3	3932,8	Palo6	Pali SLU6	2491,8
Palo7	Pali SLU3	6897,9	Palo7	Pali SLU6	7143,3
Palo8	Pali SLU3	5978,3	Palo8	Pali SLU6	5272,5

APPALTATORE: Consorzio  Soci  		ITINERARIO NAPOLI – BARI RADDOPPIO TRATTA APICE – ORSARA I LOTTO FUNZIONALE APICE – HIRPINIA					
PROGETTAZIONE: Mandataria  Mandanti  							
PROGETTO ESECUTIVO RELAZIONE DI CALCOLO FONDAZIONI PILE P1, P2, P21, P22, P23 E P24		COMMESSA IF28	LOTTO 01	CODIFICA E ZZ CL	DOCUMENTO VI0403 002	REV. B	FOGLIO 46 di 161

Palo9	Pali SLU3	5006,4	Palo9	Pali SLU6	3238,5
-------	-----------	--------	-------	-----------	--------

SLV					
Point load	Combination	F [kN]	Point load	Combination	F [kN]
Palo1	Pali SLV1	6589,1	Palo1	Pali SLV6	1699,3
Palo2	Pali SLV1	1304,9	Palo2	Pali SLV6	118,89
Palo3	Pali SLV1	-4168,9	Palo3	Pali SLV6	-1458,5
Palo4	Pali SLV1	7707,4	Palo4	Pali SLV6	3025,9
Palo5	Pali SLV1	2858,1	Palo5	Pali SLV6	1564,8
Palo6	Pali SLV1	-2639,4	Palo6	Pali SLV6	-28,045
Palo7	Pali SLV1	8765,7	Palo7	Pali SLV6	4352,5
Palo8	Pali SLV1	4394,4	Palo8	Pali SLV6	2891,4
Palo9	Pali SLV1	-1084,3	Palo9	Pali SLV6	1423,7
Palo1	Pali SLV2	50,913	Palo1	Pali SLV7	6509,7
Palo2	Pali SLV2	5111,2	Palo2	Pali SLV7	7885
Palo3	Pali SLV2	9030,5	Palo3	Pali SLV7	9175,6
Palo4	Pali SLV2	-1606,1	Palo4	Pali SLV7	709,22
Palo5	Pali SLV2	3563,9	Palo5	Pali SLV7	2651,1
Palo6	Pali SLV2	7964,7	Palo6	Pali SLV7	4524,6
Palo7	Pali SLV2	-3146,5	Palo7	Pali SLV7	-5173,5
Palo8	Pali SLV2	2016,6	Palo8	Pali SLV7	-3308,4
Palo9	Pali SLV2	6898,8	Palo9	Pali SLV7	-1443,3
Palo1	Pali SLV3	-295,57	Palo1	Pali SLV8	-124,54
Palo2	Pali SLV3	-2074,7	Palo2	Pali SLV8	-2359,2
Palo3	Pali SLV3	-3765,3	Palo3	Pali SLV8	-4491,7
Palo4	Pali SLV3	4574,6	Palo4	Pali SLV8	5891,3
Palo5	Pali SLV3	2876,4	Palo5	Pali SLV8	3749,2
Palo6	Pali SLV3	1147,7	Palo6	Pali SLV8	1607,1
Palo7	Pali SLV3	8511,6	Palo7	Pali SLV8	10151
Palo8	Pali SLV3	7341,8	Palo8	Pali SLV8	8741,1
Palo9	Pali SLV3	5896,4	Palo9	Pali SLV8	7265,5
Palo1	Pali SLV4	6896,4	Palo1	Pali SLV9	6589,1
Palo2	Pali SLV4	7881,8	Palo2	Pali SLV9	1304,9
Palo3	Pali SLV4	8867,2	Palo3	Pali SLV9	-4168,9
Palo4	Pali SLV4	2121,2	Palo4	Pali SLV9	7707,4
Palo5	Pali SLV4	3551,8	Palo5	Pali SLV9	2858,1
Palo6	Pali SLV4	4982,3	Palo6	Pali SLV9	-2639,4
Palo7	Pali SLV4	-2934,6	Palo7	Pali SLV9	8765,7
Palo8	Pali SLV4	-1510,5	Palo8	Pali SLV9	4394,4
Palo9	Pali SLV4	28,304	Palo9	Pali SLV9	-1084,3
Palo1	Pali SLV5	4328,5	Palo1	Pali SLV10	50,913
Palo2	Pali SLV5	5750,3	Palo2	Pali SLV10	5111,2

APPALTATORE: Consorzio Soci 		ITINERARIO NAPOLI – BARI RADDOPPIO TRATTA APICE – ORSARA I LOTTO FUNZIONALE APICE – HIRPINIA					
PROGETTAZIONE: Mandataria Mandanti 							
PROGETTO ESECUTIVO RELAZIONE DI CALCOLO FONDAZIONI PILE P1, P2, P21, P22, P23 E P24		COMMESSA IF28	LOTTO 01	CODIFICA E ZZ CL	DOCUMENTO VI0403 002	REV. B	FOGLIO 47 di 161

Palo3	Pali SLV5	7050,7	Palo3	Pali SLV10	9030,5
Palo4	Pali SLV5	2920,8	Palo4	Pali SLV10	-1606,1
Palo5	Pali SLV5	4342,6	Palo5	Pali SLV10	3563,9
Palo6	Pali SLV5	5764,4	Palo6	Pali SLV10	7964,7
Palo7	Pali SLV5	1513,1	Palo7	Pali SLV10	-3146,5
Palo8	Pali SLV5	2934,9	Palo8	Pali SLV10	2016,6
Palo9	Pali SLV5	4356,7	Palo9	Pali SLV10	6898,8

10.2 SOLLECITAZIONI

10.2.1 Sollecitazioni SLV



Figura 10.4 M11 max SLV



Figura 10.5 M11 min SLV

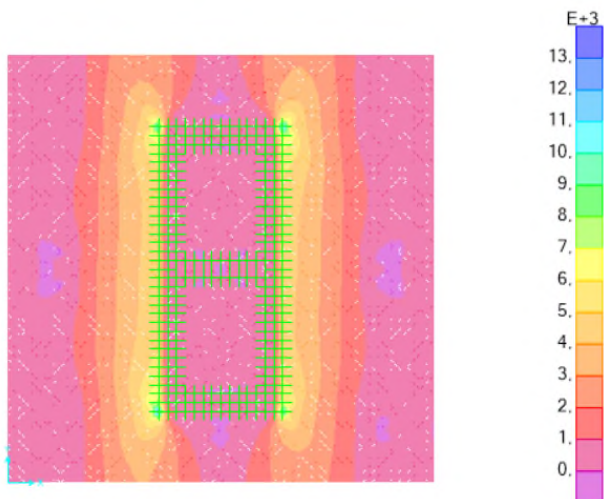

Figura 10.6 M22 max SLV



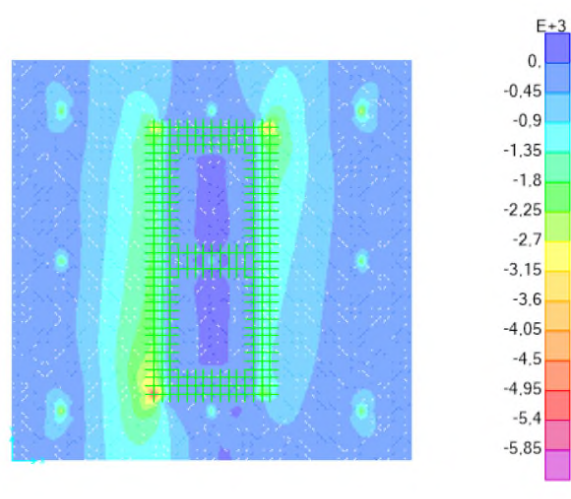

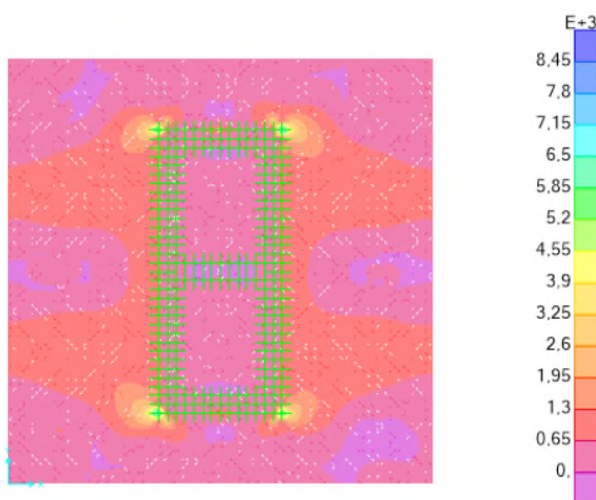

Figura 10.7 M22 min SLV

APPALTATORE: Consorzio Soci   	ITINERARIO NAPOLI – BARI RADDOPPIO TRATTA APICE – ORSARA I LOTTO FUNZIONALE APICE – HIRPINIA																	
PROGETTAZIONE: Mandataria Mandanti   	<table border="1" style="width: 100%; border-collapse: collapse;"> <tr> <td style="width: 16.6%;">COMMESSA</td> <td style="width: 16.6%;">LOTTO</td> <td style="width: 16.6%;">CODIFICA</td> <td style="width: 16.6%;">DOCUMENTO</td> <td style="width: 16.6%;">REV.</td> <td style="width: 16.6%;">FOGLIO</td> </tr> <tr> <td>IF28</td> <td>01</td> <td>E ZZ CL</td> <td>VI0403 002</td> <td>B</td> <td>48 di 161</td> </tr> </table>						COMMESSA	LOTTO	CODIFICA	DOCUMENTO	REV.	FOGLIO	IF28	01	E ZZ CL	VI0403 002	B	48 di 161
COMMESSA	LOTTO	CODIFICA	DOCUMENTO	REV.	FOGLIO													
IF28	01	E ZZ CL	VI0403 002	B	48 di 161													
PROGETTO ESECUTIVO RELAZIONE DI CALCOLO FONDAZIONI PILE P1, P2, P21, P22, P23 E P24																		

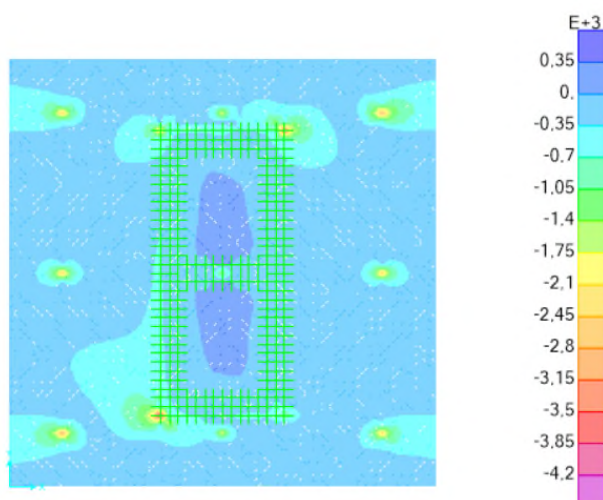

Figura 10.8 M12 max SLV



Figura 10.9 M12 min SLV

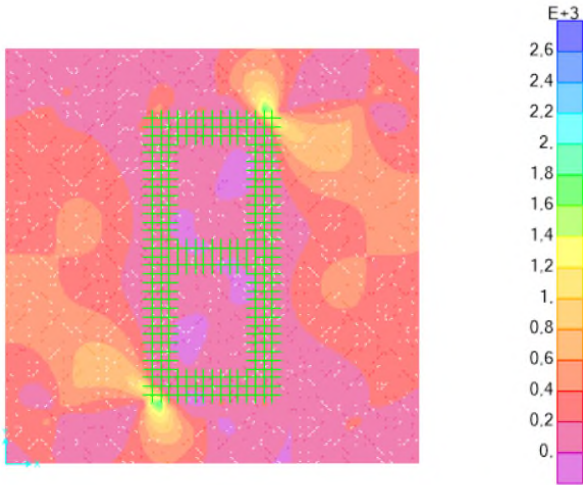

Figura 10.10 V13 max SLV



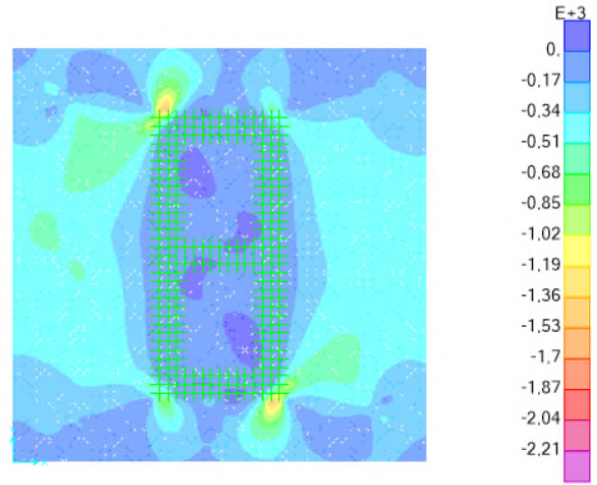



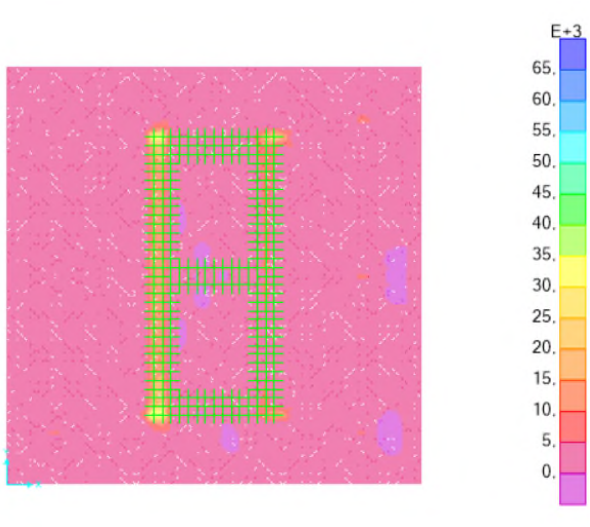

Figura 10.11 V13 min SLV

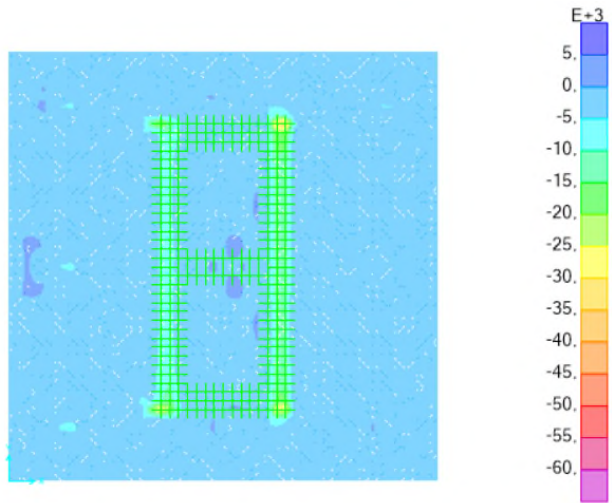
APPALTATORE: Consorzio Soci   	ITINERARIO NAPOLI – BARI					
PROGETTAZIONE: Mandataria Mandanti   	RADDOPPIO TRATTA APICE – ORSARA I LOTTO FUNZIONALE APICE – HIRPINIA					
PROGETTO ESECUTIVO RELAZIONE DI CALCOLO FONDAZIONI PILE P1, P2, P21, P22, P23 E P24	COMMESSA IF28	LOTTO 01	CODIFICA E ZZ CL	DOCUMENTO VI0403 002	REV. B	FOGLIO 49 di 161



Figura 10.12 V23 max SLV



Figura 10.13 V23 min SLV

10.2.2 Sollecitazioni SLU

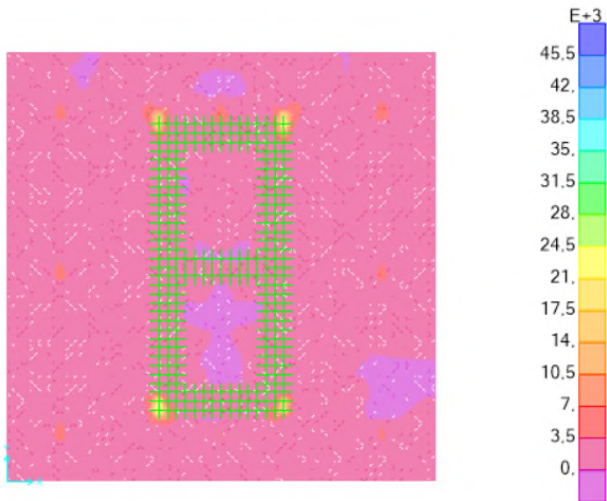

Figura 10.14 M11 max SLU

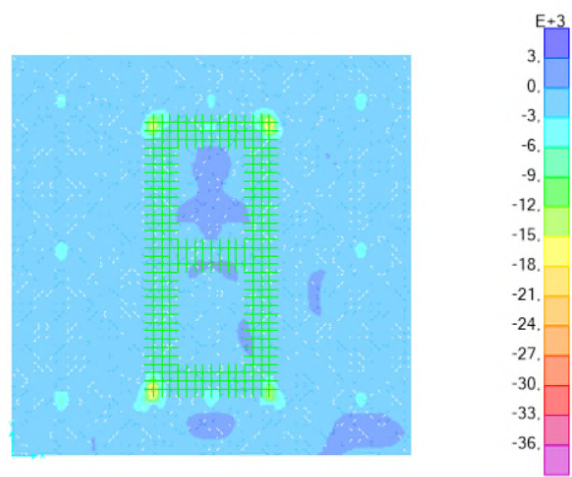



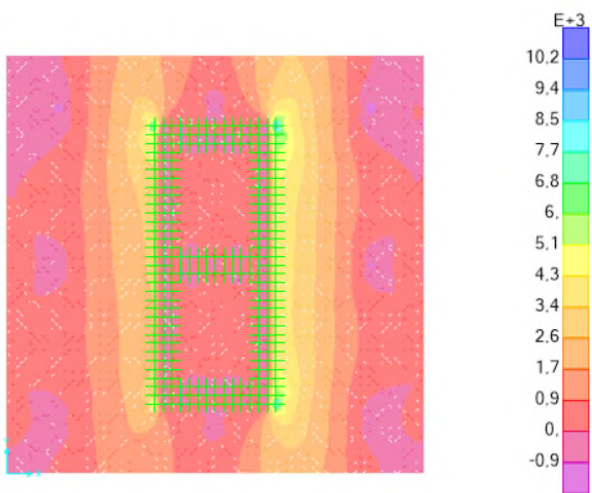

Figura 10.15 M11 min SLU

APPALTATORE: Consorzio Soci   	ITINERARIO NAPOLI – BARI RADDOPPIO TRATTA APICE – ORSARA I LOTTO FUNZIONALE APICE – HIRPINIA					
PROGETTAZIONE: Mandataria Mandanti   	COMMESSA IF28	LOTTO 01	CODIFICA E ZZ CL	DOCUMENTO VI0403 002	REV. B	FOGLIO 50 di 161
PROGETTO ESECUTIVO RELAZIONE DI CALCOLO FONDAZIONI PILE P1, P2, P21, P22, P23 E P24						

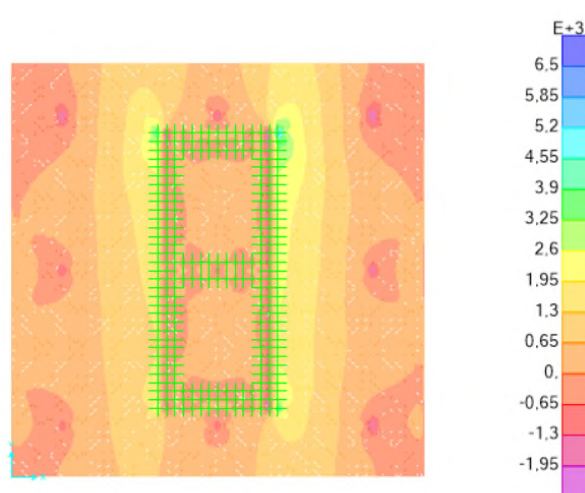

Figura 10.16 M22 max SLU



Figura 10.17 M22 min SLU

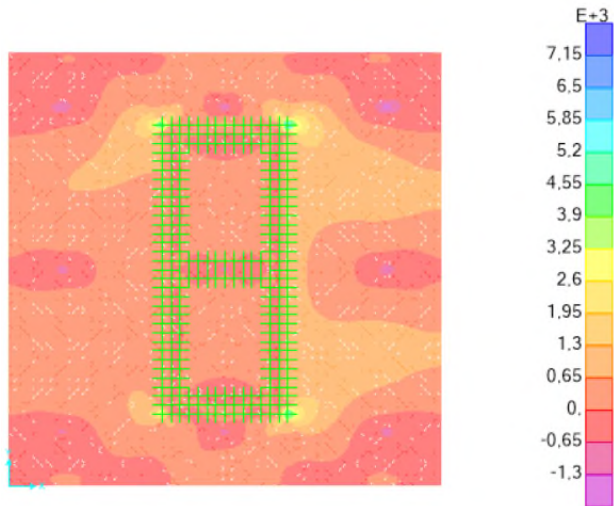

Figura 10.18 M12 max SLU



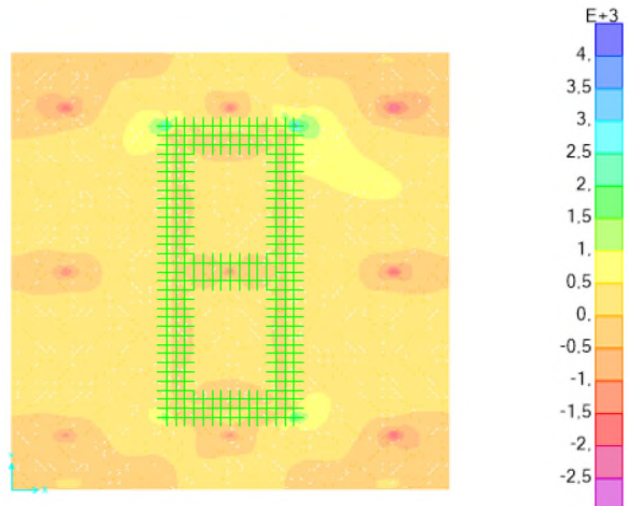

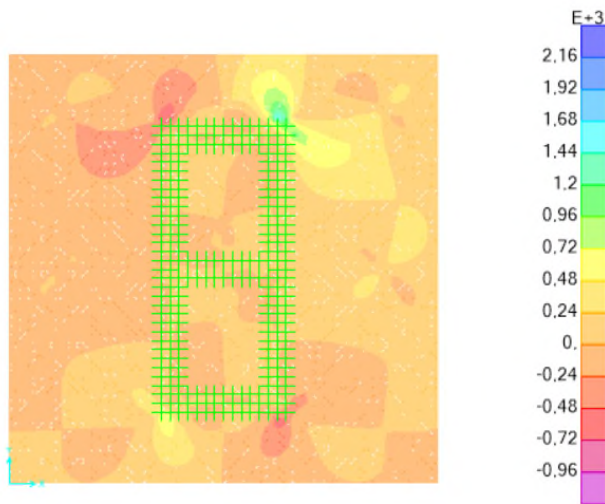

Figura 10.19 M12 min SLU

APPALTATORE: Consorzio Soci   	ITINERARIO NAPOLI – BARI RADDOPPIO TRATTA APICE – ORSARA I LOTTO FUNZIONALE APICE – HIRPINIA																	
PROGETTAZIONE: Mandataria Mandanti   	<table border="1" style="width: 100%; border-collapse: collapse;"> <tr> <td style="width: 16.6%;">COMMESSA</td> <td style="width: 16.6%;">LOTTO</td> <td style="width: 16.6%;">CODIFICA</td> <td style="width: 16.6%;">DOCUMENTO</td> <td style="width: 16.6%;">REV.</td> <td style="width: 16.6%;">FOGLIO</td> </tr> <tr> <td>IF28</td> <td>01</td> <td>E ZZ CL</td> <td>VI0403 002</td> <td>B</td> <td>51 di 161</td> </tr> </table>						COMMESSA	LOTTO	CODIFICA	DOCUMENTO	REV.	FOGLIO	IF28	01	E ZZ CL	VI0403 002	B	51 di 161
COMMESSA	LOTTO	CODIFICA	DOCUMENTO	REV.	FOGLIO													
IF28	01	E ZZ CL	VI0403 002	B	51 di 161													
PROGETTO ESECUTIVO RELAZIONE DI CALCOLO FONDAZIONI PILE P1, P2, P21, P22, P23 E P24																		

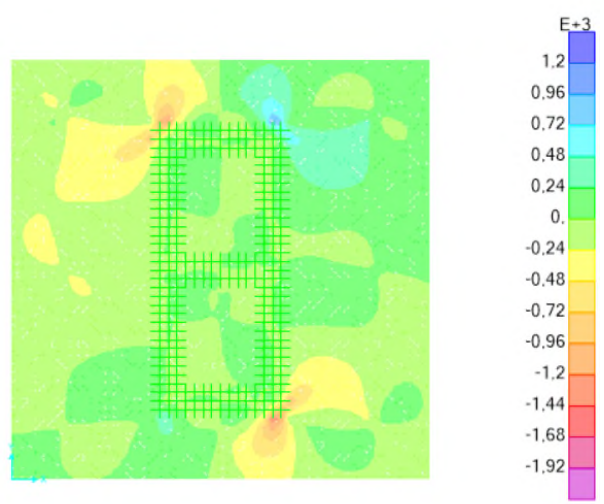

Figura 10.20 V13 max SLU



Figura 10.21 V13 min SLU

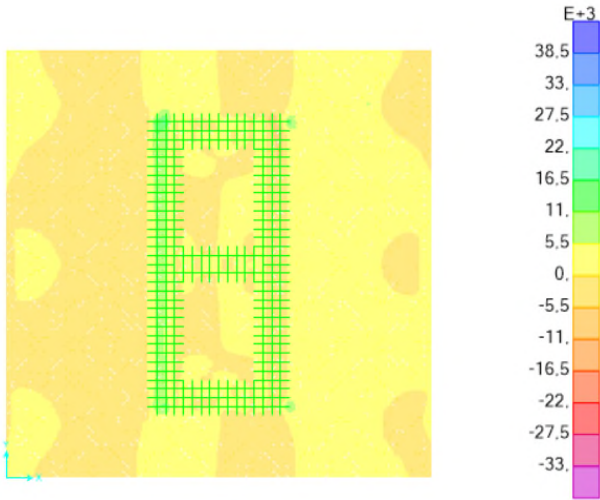

Figura 10.22 V23 max SLU



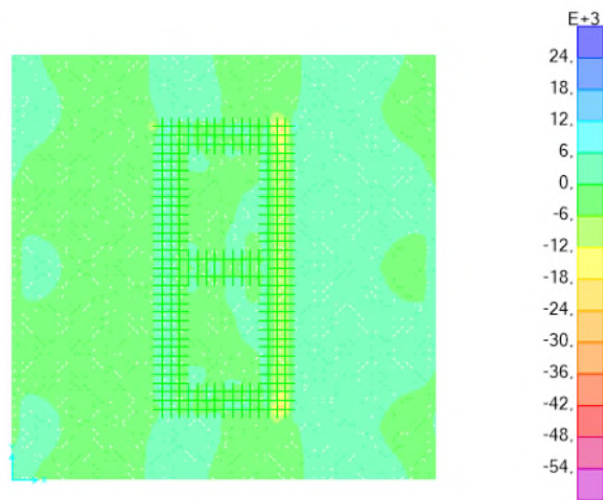



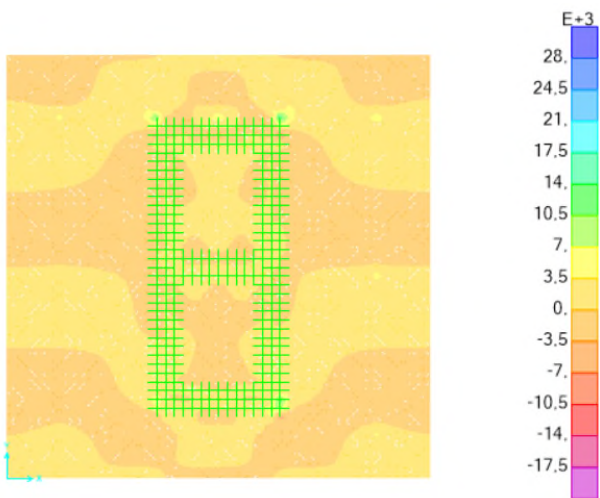

Figura 10.23 V23 min SLU

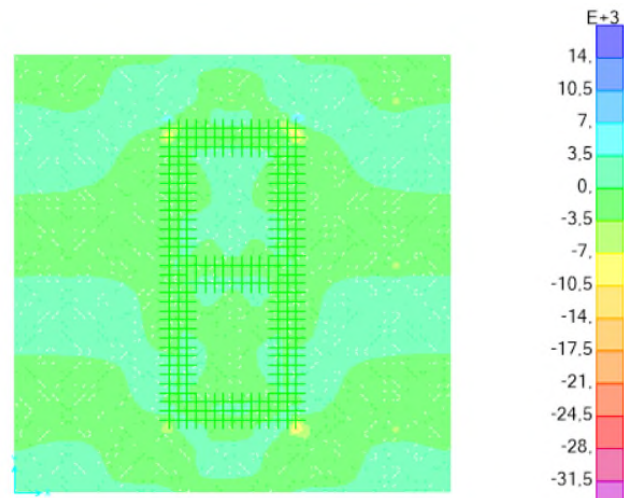
APPALTATORE: Consorzio Soci   	ITINERARIO NAPOLI – BARI RADDOPPIO TRATTA APICE – ORSARA I LOTTO FUNZIONALE APICE – HIRPINIA																	
PROGETTAZIONE: Mandataria Mandanti   	<table border="1" style="width: 100%; border-collapse: collapse;"> <tr> <td style="width: 16.6%;">COMMESSA</td> <td style="width: 16.6%;">LOTTO</td> <td style="width: 16.6%;">CODIFICA</td> <td style="width: 16.6%;">DOCUMENTO</td> <td style="width: 16.6%;">REV.</td> <td style="width: 16.6%;">FOGLIO</td> </tr> <tr> <td>IF28</td> <td>01</td> <td>E ZZ CL</td> <td>VI0403 002</td> <td>B</td> <td>52 di 161</td> </tr> </table>						COMMESSA	LOTTO	CODIFICA	DOCUMENTO	REV.	FOGLIO	IF28	01	E ZZ CL	VI0403 002	B	52 di 161
COMMESSA	LOTTO	CODIFICA	DOCUMENTO	REV.	FOGLIO													
IF28	01	E ZZ CL	VI0403 002	B	52 di 161													
PROGETTO ESECUTIVO RELAZIONE DI CALCOLO FONDAZIONI PILE P1, P2, P21, P22, P23 E P24																		

10.2.3 Sollecitazioni SLE



Figura 10.24 M11 max SLE



Figura 10.25 M11 min SLE

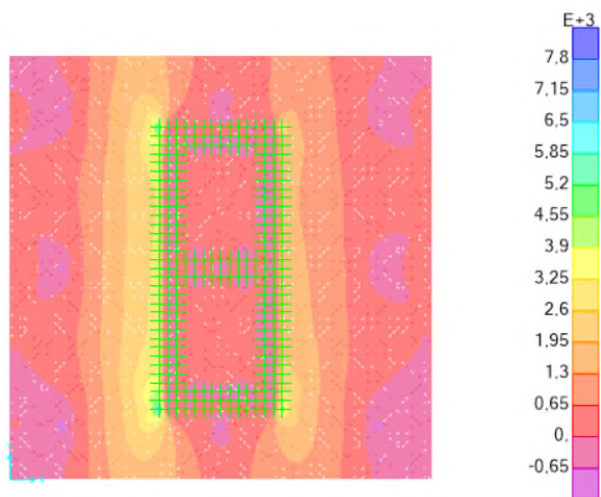

Figura 10.26 M22 max SLE



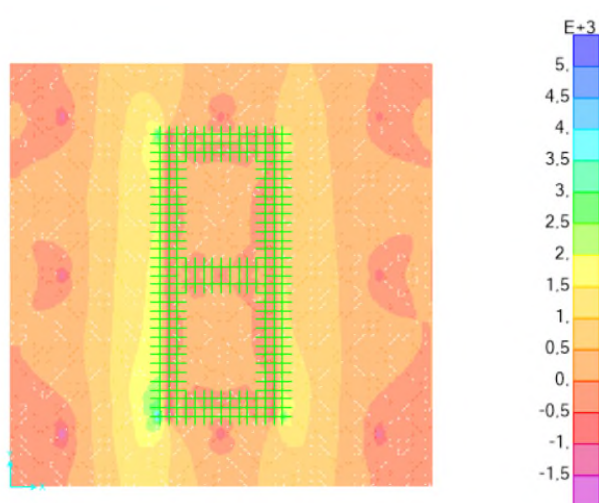



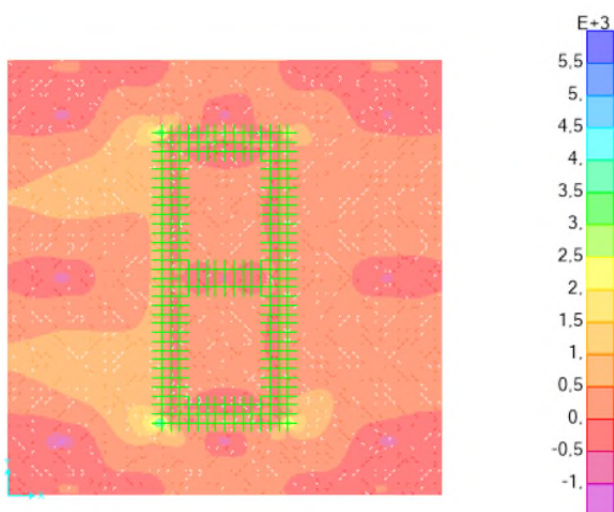

Figura 10.27 M22 min SLE

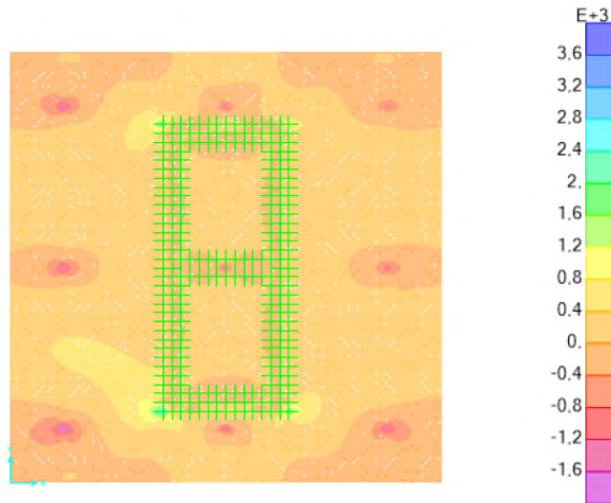
APPALTATORE: Consorzio Soci   	ITINERARIO NAPOLI – BARI RADDOPPIO TRATTA APICE – ORSARA I LOTTO FUNZIONALE APICE – HIRPINIA																	
PROGETTAZIONE: Mandataria Mandanti   	<table border="1" style="width: 100%; border-collapse: collapse;"> <tr> <td style="width: 16.6%;">COMMESSA</td> <td style="width: 16.6%;">LOTTO</td> <td style="width: 16.6%;">CODIFICA</td> <td style="width: 16.6%;">DOCUMENTO</td> <td style="width: 16.6%;">REV.</td> <td style="width: 16.6%;">FOGLIO</td> </tr> <tr> <td>IF28</td> <td>01</td> <td>E ZZ CL</td> <td>VI0403 002</td> <td>B</td> <td>53 di 161</td> </tr> </table>						COMMESSA	LOTTO	CODIFICA	DOCUMENTO	REV.	FOGLIO	IF28	01	E ZZ CL	VI0403 002	B	53 di 161
COMMESSA	LOTTO	CODIFICA	DOCUMENTO	REV.	FOGLIO													
IF28	01	E ZZ CL	VI0403 002	B	53 di 161													
PROGETTO ESECUTIVO RELAZIONE DI CALCOLO FONDAZIONI PILE P1, P2, P21, P22, P23 E P24																		



Figura 10.28 M12 max SLE



Figura 10.29 M12 min SLE

APPALTATORE: Consorzio Soci 	ITINERARIO NAPOLI – BARI RADDOPPIO TRATTA APICE – ORSARA I LOTTO FUNZIONALE APICE – HIRPINIA					
PROGETTAZIONE: Mandataria Mandanti 						
PROGETTO ESECUTIVO RELAZIONE DI CALCOLO FONDAZIONI PILE P1, P2, P21, P22, P23 E P24	COMMESSA IF28	LOTTO 01	CODIFICA E ZZ CL	DOCUMENTO VI0403 002	REV. B	FOGLIO 54 di 161

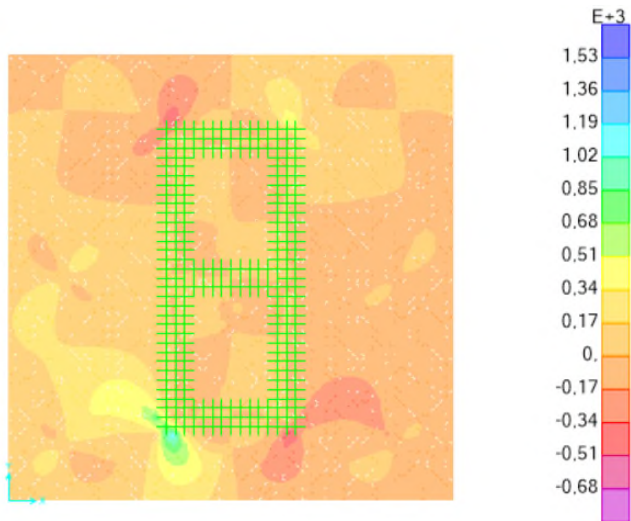
10.3 VERIFICHE SLU/SLE

10.3.1 Sollecitazioni di verifica

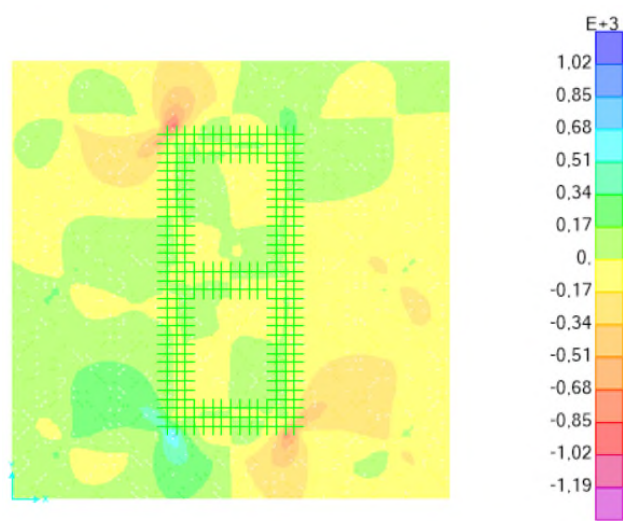
A partire dallo stato di sollecitazione determinato attraverso il software, sono state definite section-cut di 1m sul filo della pila nelle due direzioni.

La definizione delle section-cut permette attraverso il post-processing definire la sollecitazione media su un metro di piastra, ciò al fine di by-passare la concentrazione delle azioni su porzioni infinitesime di piastra, che sono dovuti alla schematizzazione dei vincoli come puntuali.

Quindi le azioni interne sono definite secondo sezioni come indicato nelle seguenti immagini:



Figura 10.30 Definizione delle Section-cut

A partire dalle azioni così definite è possibile involuppare geometricamente secondo i due assi di simmetria del plinto di fondazione in modo da garantire la copertura massima delle azioni sollecitanti, in aggiunta ad uno schema d'armatura doppiamente simmetrico.

Di seguito sono riportati i vari involuppi geometrici:

Longitudinale	Trasversale
Max (L1, L12, L13, L24)	Max (T1, T12, T13, T24)
Max (L2, L11, L14, L23)	Max (T2, T11, T14, T23)
Max (L3, L10, L15, L22)	Max (T3, T10, T15, T22)
Max (L4, L9, L16, L21)	Max (T4, T9, T16, T21)
Max (L5, L8, L17, L20)	Max (T5, T8, T17, T20)
Max (L6, L7, L18, L19)	Max (T6, T7, T18, T19)

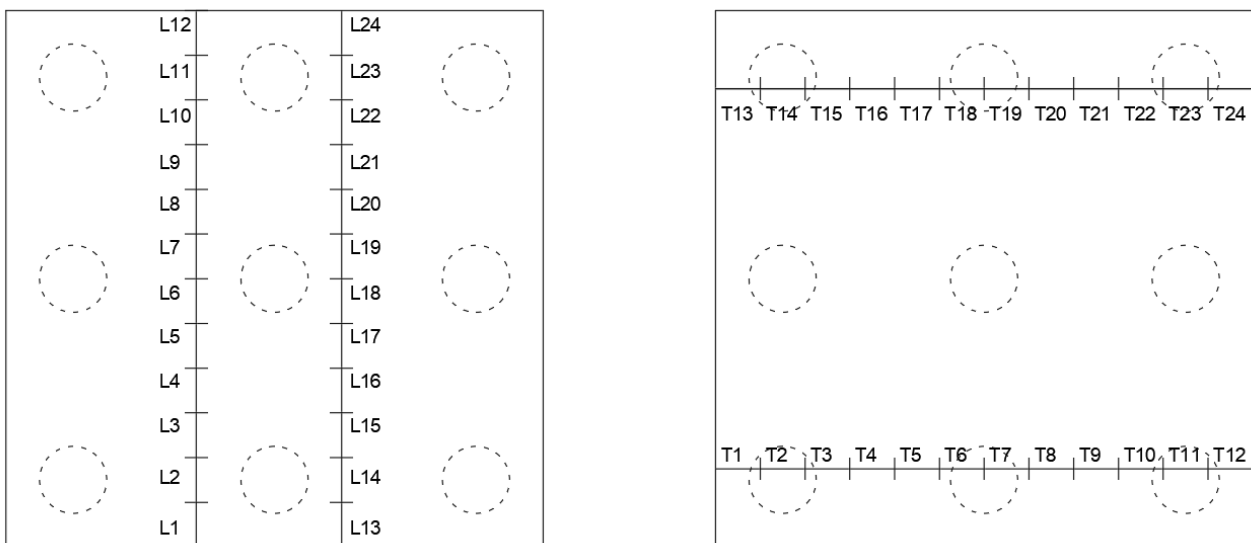
APPALTATORE: Consorzio  Soci  		ITINERARIO NAPOLI – BARI RADDOPPIO TRATTA APICE – ORSARA I LOTTO FUNZIONALE APICE – HIRPINIA					
PROGETTAZIONE: Mandataria  Mandanti  							
PROGETTO ESECUTIVO RELAZIONE DI CALCOLO FONDAZIONI PILE P1, P2, P21, P22, P23 E P24		COMMESSA IF28	LOTTO 01	CODIFICA E ZZ CL	DOCUMENTO VI0403 002	REV. B	FOGLIO 55 di 161

Il momento torcente è stato sommato in modulo a fine di massimizzare l'effetto della flessione.

Di seguito sono riportate le sollecitazioni ai vari stati limite.

	EnvSLV	M		V		
		min	max	min	max	
	Longitudinale	1	-4427,49	2680,223	-385,079	
2		-6402,57	4150,536	-3472,12	2755,536	max(L2,L11,L14,L23)
3		-10763,9	6487,229	-5559,41	4182,138	max(L3,L10,L15,L22)
4		-5400,21	3377,544	-1173,33	1640,078	max(L4,L9,L16,L21)
5		-4760,33	2887,701	-1196,65	1433,581	max(L5,L8,L17,L20)
6		-4673,95	2624,318	-1430,99	1512,371	max(L6,L7,L18,L19)

	EnvSLV	M		V		
		min	max	min	max	
	Trasversale	1	-1190,37	1014,94	-1010,02	
2		-1290,93	1145,006	-2394,09	1136,136	max(T2,T11,T14,T23)
3		-1522,28	1943,744	-1108,43	575,245	max(T3,T10,T15,T22)
4		-2114,62	2922,338	-1868,82	1133,021	max(T4,T9,T16,T21)
5		-5429,31	7814,014	-5328,2	3991,712	max(T5,T8,T17,T20)
6		-1608,76	1745,509	-1856,53	1063,639	max(T6,T7,T18,T19)

	EnvSLU	M		V		
		min	max	min	max	
	Longitudinale	1	-3162,75	-529,187	-109,677	
2		-4509,38	-572,582	-2054,29	1382,664	max(L2,L11,L14,L23)
3		-7940,91	-816,839	-4030,19	2186,345	max(L3,L10,L15,L22)
4		-4230,43	-677,969	-933,575	807,191	max(L4,L9,L16,L21)
5		-3756,66	-809,363	-961,239	666,675	max(L5,L8,L17,L20)
6		-3728,93	-904,672	-1168,69	689,986	max(L6,L7,L18,L19)

	EnvSLU	M		V		
		min	max	min	max	
	Trasversale	1	-432,698	464,2468	-672,386	
2		-205,105	206,579	-1564,88	-202,859	max(T2,T11,T14,T23)
3		-495,343	296,1485	-739,456	-58,167	max(T3,T10,T15,T22)
4		-1356,19	323,571	-1237,52	272,245	max(T4,T9,T16,T21)
5		-3299,29	1977,66	-2854,39	340,445	max(T5,T8,T17,T20)
6		-496,219	784,2529	-856,8	128,639	max(T6,T7,T18,T19)

APPALTATORE: Consorzio  Soci  		ITINERARIO NAPOLI – BARI RADDOPPIO TRATTA APICE – ORSARA I LOTTO FUNZIONALE APICE – HIRPINIA					
PROGETTAZIONE: Mandataria  Mandanti  							
PROGETTO ESECUTIVO RELAZIONE DI CALCOLO FONDAZIONI PILE P1, P2, P21, P22, P23 E P24		COMMESSA IF28	LOTTO 01	CODIFICA E ZZ CL	DOCUMENTO VI0403 002	REV. B	FOGLIO 56 di 161

Longitudinale	EnvSLE	M		
		min	max	
	1	-2132,65	-330,036	
2	-2350,36	-387,7	max(L2,L11,L14,L23)	
3	-3678,19	-673,286	max(L3,L10,L15,L22)	
4	-2634,55	-424,228	max(L4,L9,L16,L21)	
5	-2205,95	-496,133	max(L5,L8,L17,L20)	
6	-2121,49	-585,142	max(L6,L7,L18,L19)	

Trasversale	EnvSLE	M		
		min	max	
	1	-235,178	168,7069	
2	-295,851	306,0092	max(T2,T11,T14,T23)	
3	-440,858	773,412	max(T3,T10,T15,T22)	
4	-809,786	1337,536	max(T4,T9,T16,T21)	
5	-1879,96	3845,365	max(T5,T8,T17,T20)	
6	-679,369	720,9632	max(T6,T7,T18,T19)	

Inviluppando SLU ed SLV, per le verifiche agli stati limite ultimi si ottiene:

Longitudinale	EnvSLU/SLV	M		V		
		min	max	min	max	
	1	-4427,49	2680,223	-385,079	900,728	
2	-6402,57	4150,536	-3472,12	2755,536	max(L2,L11,L14,L23)	
3	-10763,9	6487,229	-5559,41	4182,138	max(L3,L10,L15,L22)	
4	-5400,21	3377,544	-1173,33	1640,078	max(L4,L9,L16,L21)	
5	-4760,33	2887,701	-1196,65	1433,581	max(L5,L8,L17,L20)	
6	-4673,95	2624,318	-1430,99	1512,371	max(L6,L7,L18,L19)	

Trasversale	EnvSLU/SLV	M		V		
		min	max	min	max	
	1	-1190,37	1014,94	-1010,02	505,703	
2	-1290,93	1145,006	-1197,05	1136,136	max(T2,T11,T14,T23)	
3	-1522,28	1943,744	-1108,43	575,245	max(T3,T10,T15,T22)	
4	-2114,62	2922,338	-1868,82	1133,021	max(T4,T9,T16,T21)	
5	-5429,31	7814,014	-5328,2	3991,712	max(T5,T8,T17,T20)	
6	-1608,76	1745,509	-1856,53	1063,639	max(T6,T7,T18,T19)	

APPALTATORE: Consorzio HirpiniaAV Soci salini impregilo ASTALDI	ITINERARIO NAPOLI – BARI RADDOPPIO TRATTA APICE – ORSARA I LOTTO FUNZIONALE APICE – HIRPINIA					
PROGETTAZIONE: Mandataria ROKSOJL Mandanti NETENGINEERING Alpina						
PROGETTO ESECUTIVO RELAZIONE DI CALCOLO FONDAZIONI PILE P1, P2, P21, P22, P23 E P24	COMMESSA IF28	LOTTO 01	CODIFICA E ZZ CL	DOCUMENTO VI0403 002	REV. B	FOGLIO 57 di 161

10.3.2 Verifiche a flessione e taglio

I criteri di verifica per gli stati limite ultimi e per gli stati limite di esercizio (fessurazione e limiti tensionali) sono stati esplicitati in precedenza.

Caratteristiche materiali e parametri di verifica sono sintetizzati di seguito:

materiali			
calcestruzzo		acciaio	
R_{ck}	35 [MPa]	f_{yk}	450 [MPa]
f_{ck}	29,1 [MPa]	γ_s	1,15
γ_c	1,5	f_{yd}	391,3 [MPa]
α_{cc}	0,85	E_s	210000 [MPa]
f_{cd}	16,5 [MPa]	ϵ_{uk}	75 [%]
ν	0,530		
ϵ_{c2}	2,0 [%]		
ϵ_{cu2}	3,5 [%]		
α_e	15,0		
k_t	0,4	valori limite	
k_1	0,8	0,45 f_{ck}	13,1 [MPa]
k_3	3,4	0,8 f_{yk}	360,0 [MPa]
k_4	0,425	$w_{k,lim}$	0,2 [mm]

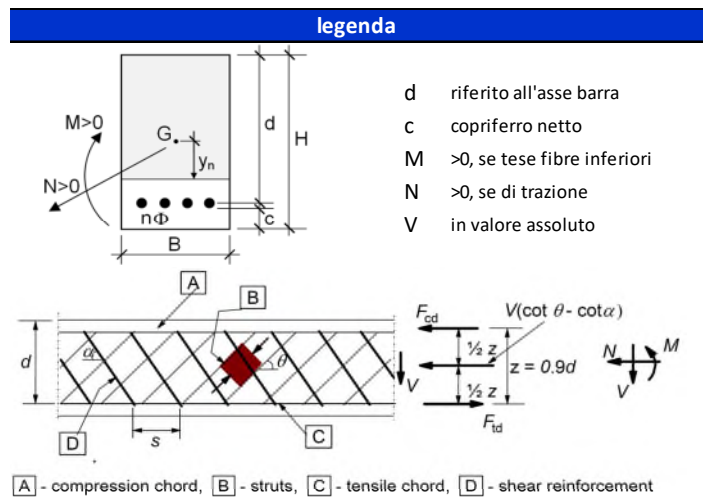

L'armatura base è composta da una maglia di $\phi 28$ con passo 15cm, la quale viene aggiunto un raffittimento e/o uno strato aggiuntivo nelle zone maggiormente sollecitate, in quale possono essere a passo 30cm o 15cm. L'armatura in direzione trasversale è posta sopra la longitudinale motivo per cui nelle seguenti verifiche si ha un copriferro maggiore nelle armature trasversali. Si considera che gli spilli non siano legati alle barre più interne, motivo per cui non sono considerate nel calcolo del copriferro.

A favore di sicurezza nelle seguenti verifiche si considera solo lo strato più esterno di armatura compressa.

APPALTATORE: Consorzio Soci   	ITINERARIO NAPOLI – BARI RADDOPPIO TRATTA APICE – ORSARA I LOTTO FUNZIONALE APICE – HIRPINIA					
PROGETTAZIONE: Mandataria Mandanti   						
PROGETTO ESECUTIVO RELAZIONE DI CALCOLO FONDAZIONI PILE P1, P2, P21, P22, P23 E P24	COMMESSA IF28	LOTTO 01	CODIFICA E ZZ CL	DOCUMENTO VI0403 002	REV. B	FOGLIO 58 di 161

Sezione 1 longitudinale:

- *verifica armature inferiori:*

geometria				
sezione trasversale				
B	H	c	d	z
[cm]	[cm]	[cm]	[cm]	[cm]
100	250	5,0	243,6	219,2
armatura longitudinale				
nbarre	φ	d	Asl	
	[mm]	[cm]	[cm ²]	
6,66667	28	6,4	41,05	
13,3333	28	243,6	82,10	
armatura a taglio				
nbracci	φ	s	α	Asw
	[mm]	[cm]	[°]	[cm ²]
3,33333	16	60	90	6,70

- *verifica armature superiore:*

geometria				
sezione trasversale				
B	H	c	d	z
[cm]	[cm]	[cm]	[cm]	[cm]
100	250	5,0	243,6	219,2
armatura longitudinale				
nbarre	φ	d	Asl	
	[mm]	[cm]	[cm ²]	
13,3333	28	6,4	82,10	
6,66667	28	243,6	41,05	
armatura a taglio				
nbracci	φ	s	α	Asw
	[mm]	[cm]	[°]	[cm ²]
3,33333	16	60	90	6,70

sollecitazioni e risultati	
SLE	SLU
MEk 2133,00 [kNm]	MEd 4428,00 [kNm]
NEk 0 [kN]	NEd 0 [kN]
tensioni e fessure	
Mdec 0,0 [kNm]	
Mcr 2976,7 [kNm]	
yn -63,35 [cm]	
σ _{c,min} -2,6 [MPa]	
σ _{s,min} -35,0 [MPa]	
σ _{s,max} 115,4 [MPa]	
k ₂ 0,5	
ε _{sm-ε_{cm}} - [%o]	
Sr,max - [cm]	
Wk - [mm]	
presso-flessione	
MRd 7633,6 [kNm]	
FS 1,72	
taglio	
VRdc 804,5 [kN]	
predisporre armatura a taglio	
VRds 1659,8 [kN]	
VRdmax 8287,0 [kN]	
θ 30,0 [°]	
sezione duttile	
ai 189,9 [cm]	

sollecitazioni e risultati	
SLE	SLU
MEk 0,00 [kNm]	MEd 2681,00 [kNm]
NEk 0 [kN]	NEd 0 [kN]
VEd 901,00 [kN]	
tensioni e fessure	
Mdec 0,0 [kNm]	
Mcr -2976,7 [kNm]	
yn 63,35 [cm]	
σ _{c,min} 0,0 [MPa]	
σ _{s,min} 0,0 [MPa]	
σ _{s,max} 0,0 [MPa]	
k ₂ 0,5	
ε _{sm-ε_{cm}} - [%o]	
Sr,max - [cm]	
Wk - [mm]	
presso-flessione	
MRd 3840,4 [kNm]	
FS 1,43	
taglio	
VRdc 670,6 [kN]	
predisporre armatura a taglio	
VRds 1659,8 [kN]	
VRdmax 8287,0 [kN]	
θ 30,0 [°]	
sezione duttile	
ai 189,9 [cm]	

APPALTATORE: Consorzio Soci   	ITINERARIO NAPOLI – BARI RADDOPPIO TRATTA APICE – ORSARA I LOTTO FUNZIONALE APICE – HIRPINIA					
PROGETTAZIONE: Mandataria Mandanti   						
PROGETTO ESECUTIVO RELAZIONE DI CALCOLO FONDAZIONI PILE P1, P2, P21, P22, P23 E P24	COMMESSA IF28	LOTTO 01	CODIFICA E ZZ CL	DOCUMENTO VI0403 002	REV. B	FOGLIO 59 di 161

Sezione 2 longitudinale:

- *verifica armature inferiori:*

geometria				
sezione trasversale				
B	H	c	d	z
[cm]	[cm]	[cm]	[cm]	[cm]
100	250	5,0	243,6	219,2
armatura longitudinale				
nbarre	φ	d	Asl	
	[mm]	[cm]	[cm ²]	
10	28	6,4	61,58	
13,3333	28	243,6	82,10	
armatura a taglio				
nbracci	φ	s	α	Asw
	[mm]	[cm]	[°]	[cm ²]
3,33333	16	30	90	6,70

- *verifica armature superiore:*

geometria				
sezione trasversale				
B	H	c	d	z
[cm]	[cm]	[cm]	[cm]	[cm]
100	250	5,0	243,6	219,2
armatura longitudinale				
nbarre	φ	d	Asl	
	[mm]	[cm]	[cm ²]	
13,3333	28	6,4	82,10	
10	28	243,6	61,58	
armatura a taglio				
nbracci	φ	s	α	Asw
	[mm]	[cm]	[°]	[cm ²]
3,33333	16	30	90	6,70

sollecitazioni e risultati	
SLE	SLU
MEk 2351,00 [kNm]	MEd 6403,00 [kNm]
NEk 0 [kN]	NEd 0 [kN]
VEd 3472,00 [kN]	
tensioni e fessure	
Mdec 0,0 [kNm]	
Mcr 3025,4 [kNm]	
yn -65,42 [cm]	
σc,min -2,7 [MPa]	
σs,min -36,5 [MPa]	
σs,max 126,3 [MPa]	
k2 0,5	
εsm-εcm - [%o]	
Sr,max - [cm]	
wk - [mm]	
presso-flessione	
MRd 7646,6 [kNm]	
FS 1,19	
taglio	
VRdc 804,5 [kN]	
predisporre armatura a taglio	
VRds 4110,1 [kN]	
VRdmax 7330,3 [kN]	
θ 25,0 [°]	
sezione duttile	
ai 235,1 [cm]	

sollecitazioni e risultati	
SLE	SLU
MEk 0,00 [kNm]	MEd 4151,00 [kNm]
NEk 0 [kN]	NEd 0 [kN]
VEd 3472,00 [kN]	
tensioni e fessure	
Mdec 0,0 [kNm]	
Mcr -3025,4 [kNm]	
yn 65,42 [cm]	
σc,min 0,0 [MPa]	
σs,min 0,0 [MPa]	
σs,max 0,0 [MPa]	
k2 0,5	
εsm-εcm - [%o]	
Sr,max - [cm]	
wk - [mm]	
presso-flessione	
MRd 5746,3 [kNm]	
FS 1,38	
taglio	
VRdc 731,0 [kN]	
predisporre armatura a taglio	
VRds 4110,1 [kN]	
VRdmax 7330,3 [kN]	
θ 25,0 [°]	
sezione duttile	
ai 235,1 [cm]	

APPALTATORE: Consorzio Soci   	ITINERARIO NAPOLI – BARI RADDOPPIO TRATTA APICE – ORSARA I LOTTO FUNZIONALE APICE – HIRPINIA					
PROGETTAZIONE: Mandataria Mandanti   						
PROGETTO ESECUTIVO RELAZIONE DI CALCOLO FONDAZIONI PILE P1, P2, P21, P22, P23 E P24	COMMESSA IF28	LOTTO 01	CODIFICA E ZZ CL	DOCUMENTO VI0403 002	REV. B	FOGLIO 60 di 161

Sezione 3 longitudinale:

- *verifica armature inferiori:*

geometria				
sezione trasversale				
B	H	c	d	z
[cm]	[cm]	[cm]	[cm]	[cm]
100	250	5,0	241,7	217,6
armatura longitudinale				
nbarre	φ	d	Asl	
	[mm]	[cm]	[cm ²]	
13,3333	28	6,4	82,10	
6,66667	28	238,0	41,05	
13,3333	28	243,6		
armatura a taglio				
nbracci	φ	s	α	Asw
	[mm]	[cm]	[°]	[cm ²]
3,33333	16	15	90	6,70

- *verifica armature superiore:*

geometria				
sezione trasversale				
B	H	c	d	z
[cm]	[cm]	[cm]	[cm]	[cm]
100	250	5,0	243,6	219,2
armatura longitudinale				
nbarre	φ	d	Asl	
	[mm]	[cm]	[cm ²]	
13,3333	28	6,4	82,10	
6,7E-08	28	238,0	0,00	
13,3333	28	243,6	82,10	
armatura a taglio				
nbracci	φ	s	α	Asw
	[mm]	[cm]	[°]	[cm ²]
3,33333	16	15	90	6,70

sollecitazioni e risultati	
SLE	SLU
MEk 3679,00 [kNm]	MEd 10764,00 [kNm]
NEk 0 [kN]	NEd 0 [kN]
VEd 5560,00 [kN]	
tensioni e fessure	
Mdec 0,0 [kNm]	
Mcr 3268,8 [kNm]	
yn -55,61 [cm]	
σ _{c,min} -3,6 [MPa]	
σ _{s,min} -49,0 [MPa]	
σ _{s,max} 135,6 [MPa]	
k ₂ 0,5	
ε _{sm-εcm} 0,46 [‰]	
S _{r,max} 25,9 [cm]	
w _k 0,120 [mm]	
presso-flessione	
MRd 11347,4 [kNm]	
FS 1,05	
taglio	
VRdc 917,1 [kN]	
predisporre armatura a taglio	
VRds 6588,3 [kN]	
VRdmax 8223,5 [kN]	
θ 30,0 [°]	
sezione duttile	
ai 188,4 [cm]	

sollecitazioni e risultati	
SLE	SLU
MEk 0,00 [kNm]	MEd 6488,00 [kNm]
NEk 0 [kN]	NEd 0 [kN]
VEd 5560,00 [kN]	
tensioni e fessure	
Mdec 0,0 [kNm]	
Mcr -3072,1 [kNm]	
yn 67,39 [cm]	
σ _{c,min} 0,0 [MPa]	
σ _{s,min} 0,0 [MPa]	
σ _{s,max} 0,0 [MPa]	
k ₂ 0,5	
ε _{sm-εcm} - [‰]	
S _{r,max} - [cm]	
w _k - [mm]	
presso-flessione	
MRd 7650,1 [kNm]	
FS 1,18	
taglio	
VRdc 804,5 [kN]	
predisporre armatura a taglio	
VRds 6639,1 [kN]	
VRdmax 8287,0 [kN]	
θ 30,0 [°]	
sezione duttile	
ai 189,9 [cm]	

APPALTATORE: Consorzio Soci   	ITINERARIO NAPOLI – BARI RADDOPPIO TRATTA APICE – ORSARA I LOTTO FUNZIONALE APICE – HIRPINIA					
PROGETTAZIONE: Mandataria Mandanti   						
PROGETTO ESECUTIVO RELAZIONE DI CALCOLO FONDAZIONI PILE P1, P2, P21, P22, P23 E P24	COMMESSA IF28	LOTTO 01	CODIFICA E ZZ CL	DOCUMENTO VI0403 002	REV. B	FOGLIO 61 di 161

Sezione 4 longitudinale:

- *verifica armature inferiori:*

geometria				
sezione trasversale				
B	H	c	d	z
[cm]	[cm]	[cm]	[cm]	[cm]
100	250	5,0	241,7	217,6
armatura longitudinale				
nbarre	φ	d	Asl	
	[mm]	[cm]	[cm ²]	
6,66667	28	6,4	41,05	
6,66667	28	238,0	41,05	
13,33333	28	243,6	82,10	
armatura a taglio				
nbracci	φ	s	α	Asw
	[mm]	[cm]	[°]	[cm ²]
3,33333	16	30	90	6,70

- *verifica armature superiore:*

geometria				
sezione trasversale				
B	H	c	d	z
[cm]	[cm]	[cm]	[cm]	[cm]
100	250	5,0	243,6	219,2
armatura longitudinale				
nbarre	φ	d	Asl	
	[mm]	[cm]	[cm ²]	
13,3333	28	6,4	82,10	
6,7E-07	28	238,0	0,00	
6,66667	28	243,6	41,05	
armatura a taglio				
nbracci	φ	s	α	Asw
	[mm]	[cm]	[°]	[cm ²]
3,33333	16	30	90	6,70

sollecitazioni e risultati	
SLE	SLU
MEk 2635,00 [kNm]	MEd 5401,00 [kNm]
NEk 0 [kN]	NEd 0 [kN]
tensioni e fessure	
Mdec 0,0 [kNm]	
Mcr 3169,3 [kNm]	
yn -51,57 [cm]	
σ _{c,min} -2,8 [MPa]	
σ _{s,min} -38,8 [MPa]	
σ _{s,max} 98,5 [MPa]	
k ₂ 0,5	
ε _{sm} -ε _{cm} - [%o]	
S _{r,max} - [cm]	
w _k - [mm]	
presso-flessione	
MRd 11198,4 [kNm]	
FS 2,07	
taglio	
VRdc 917,1 [kN]	
predisporre armatura a taglio	
VRds 3294,1 [kN]	
VRdmax 8223,5 [kN]	
θ 30,0 [°]	
sezione duttile	
ai 188,4 [cm]	

sollecitazioni e risultati	
SLE	SLU
MEk 0,00 [kNm]	MEd 3378,00 [kNm]
NEk 0 [kN]	NEd 0 [kN]
tensioni e fessure	
Mdec 0,0 [kNm]	
Mcr -2976,7 [kNm]	
yn 63,35 [cm]	
σ _{c,min} 0,0 [MPa]	
σ _{s,min} 0,0 [MPa]	
σ _{s,max} 0,0 [MPa]	
k ₂ 0,5	
ε _{sm} -ε _{cm} - [%o]	
S _{r,max} - [cm]	
w _k - [mm]	
presso-flessione	
MRd 3840,5 [kNm]	
FS 1,14	
taglio	
VRdc 670,6 [kN]	
predisporre armatura a taglio	
VRds 3319,6 [kN]	
VRdmax 8287,0 [kN]	
θ 30,0 [°]	
sezione duttile	
ai 189,9 [cm]	

APPALTATORE: Consorzio Soci   	ITINERARIO NAPOLI – BARI RADDOPPIO TRATTA APICE – ORSARA I LOTTO FUNZIONALE APICE – HIRPINIA					
PROGETTAZIONE: Mandataria Mandanti   						
PROGETTO ESECUTIVO RELAZIONE DI CALCOLO FONDAZIONI PILE P1, P2, P21, P22, P23 E P24	COMMESSA IF28	LOTTO 01	CODIFICA E ZZ CL	DOCUMENTO VI0403 002	REV. B	FOGLIO 62 di 161

Sezione 5 longitudinale:

- *verifica armature inferiori:*

geometria				
sezione trasversale				
B	H	c	d	z
[cm]	[cm]	[cm]	[cm]	[cm]
100	250	5,0	243,6	219,2
armatura longitudinale				
nbarre	φ	d	Asl	
	[mm]	[cm]	[cm ²]	
6,66667	28	6,4	41,05	
13,3333	28	243,6	82,10	
armatura a taglio				
nbracci	φ	s	α	Asw
	[mm]	[cm]	[°]	[cm ²]
3,33333	16	60	90	6,70

- *verifica armature superiore:*

geometria				
sezione trasversale				
B	H	c	d	z
[cm]	[cm]	[cm]	[cm]	[cm]
100	250	5,0	243,6	219,2
armatura longitudinale				
nbarre	φ	d	Asl	
	[mm]	[cm]	[cm ²]	
13,3333	28	6,4	82,10	
6,66667	28	243,6	41,05	
armatura a taglio				
nbracci	φ	s	α	Asw
	[mm]	[cm]	[°]	[cm ²]
3,33333	16	60	90	6,70

sollecitazioni e risultati	
SLE	SLU
MEk 2206,00 [kNm]	MEd 4761,00 [kNm]
NEk 0 [kN]	NEd 0 [kN]
tensioni e fessure	presso-flessione
Mdec 0,0 [kNm]	MRd 7633,6 [kNm]
Mcr 2976,7 [kNm]	FS 1,60
yn -63,35 [cm]	taglio
σ _{c,min} -2,7 [MPa]	VRdc 804,5 [kN]
σ _{s,min} -36,2 [MPa]	predisporre armatura a taglio
σ _{s,max} 119,3 [MPa]	VRds 1659,8 [kN]
k ₂ 0,5	VRdmax 8287,0 [kN]
ε _{sm-ε_{cm}} - [%o]	θ 30,0 [°]
Sr,max - [cm]	sezione duttile
wk - [mm]	ai 189,9 [cm]

sollecitazioni e risultati	
SLE	SLU
MEk 0,00 [kNm]	MEd 2888,00 [kNm]
NEk 0 [kN]	NEd 0 [kN]
tensioni e fessure	presso-flessione
Mdec 0,0 [kNm]	MRd 3840,4 [kNm]
Mcr -2976,7 [kNm]	FS 1,33
yn 63,35 [cm]	taglio
σ _{c,min} 0,0 [MPa]	VRdc 670,6 [kN]
σ _{s,min} 0,0 [MPa]	predisporre armatura a taglio
σ _{s,max} 0,0 [MPa]	VRds 1659,8 [kN]
k ₂ 0,5	VRdmax 8287,0 [kN]
ε _{sm-ε_{cm}} - [%o]	θ 30,0 [°]
Sr,max - [cm]	sezione duttile
wk - [mm]	ai 189,9 [cm]

APPALTATORE: Consorzio Soci   	ITINERARIO NAPOLI – BARI RADDOPPIO TRATTA APICE – ORSARA I LOTTO FUNZIONALE APICE – HIRPINIA					
PROGETTAZIONE: Mandataria Mandanti   						
PROGETTO ESECUTIVO RELAZIONE DI CALCOLO FONDAZIONI PILE P1, P2, P21, P22, P23 E P24	COMMESSA IF28	LOTTO 01	CODIFICA E ZZ CL	DOCUMENTO VI0403 002	REV. B	FOGLIO 63 di 161

Sezione 6 longitudinale:

- *verifica armature inferiori:*

geometria				
sezione trasversale				
B	H	c	d	z
[cm]	[cm]	[cm]	[cm]	[cm]
100	250	5,0	243,6	219,2
armatura longitudinale				
nbarre	φ	d	Asl	
	[mm]	[cm]	[cm ²]	
6,66667	28	6,4	41,05	
13,3333	28	243,6	82,10	
armatura a taglio				
nbracci	φ	s	α	Asw
	[mm]	[cm]	[°]	[cm ²]
3,33333	16	60	90	6,70

- *verifica armature superiore:*

geometria				
sezione trasversale				
B	H	c	d	z
[cm]	[cm]	[cm]	[cm]	[cm]
100	250	5,0	243,6	219,2
armatura longitudinale				
nbarre	φ	d	Asl	
	[mm]	[cm]	[cm ²]	
13,3333	28	6,4	82,10	
6,66667	28	243,6	41,05	
armatura a taglio				
nbracci	φ	s	α	Asw
	[mm]	[cm]	[°]	[cm ²]
3,33333	16	60	90	6,70

sollecitazioni e risultati	
SLE	SLU
MEk 2122,00 [kNm]	MEd 4674,00 [kNm]
NEk 0 [kN]	NEd 0 [kN]
tensioni e fessure	
Mdec 0,0 [kNm]	
Mcr 2976,7 [kNm]	
yn -63,35 [cm]	
σ _{c,min} -2,6 [MPa]	
σ _{s,min} -34,9 [MPa]	
σ _{s,max} 114,8 [MPa]	
k ₂ 0,5	
ε _{sm} -ε _{cm} - [%o]	
Sr,max - [cm]	
wk - [mm]	
presso-flessione	
MRd 7633,6 [kNm]	
FS 1,63	
taglio	
VRdc 804,5 [kN]	
predisporre armatura a taglio	
VRds 1659,8 [kN]	
VRdmax 8287,0 [kN]	
θ 30,0 [°]	
sezione duttile	
ai 189,9 [cm]	

sollecitazioni e risultati	
SLE	SLU
MEk 0,00 [kNm]	MEd 2625,00 [kNm]
NEk 0 [kN]	NEd 0 [kN]
VEd 1513,00 [kN]	
tensioni e fessure	
Mdec 0,0 [kNm]	
Mcr -2976,7 [kNm]	
yn 63,35 [cm]	
σ _{c,min} 0,0 [MPa]	
σ _{s,min} 0,0 [MPa]	
σ _{s,max} 0,0 [MPa]	
k ₂ 0,5	
ε _{sm} -ε _{cm} - [%o]	
Sr,max - [cm]	
wk - [mm]	
presso-flessione	
MRd 3840,4 [kNm]	
FS 1,46	
taglio	
VRdc 670,6 [kN]	
predisporre armatura a taglio	
VRds 1659,8 [kN]	
VRdmax 8287,0 [kN]	
θ 30,0 [°]	
sezione duttile	
ai 189,9 [cm]	

APPALTATORE: Consorzio HirpiniaAV Soci salini impregio ASTALDI	ITINERARIO NAPOLI – BARI RADDOPPIO TRATTA APICE – ORSARA I LOTTO FUNZIONALE APICE – HIRPINIA					
PROGETTAZIONE: Mandataria SOJL Mandanti NETENGINEERING Alpina						
PROGETTO ESECUTIVO RELAZIONE DI CALCOLO FONDAZIONI PILE P1, P2, P21, P22, P23 E P24	COMMESSA IF28	LOTTO 01	CODIFICA E ZZ CL	DOCUMENTO VI0403 002	REV. B	FOGLIO 64 di 161

Sezione 1 trasversale:

- *verifica armature inferiori:*

geometria				
sezione trasversale				
B	H	c	d	z
[cm]	[cm]	[cm]	[cm]	[cm]
100	250	5,0	243,6	219,2
armatura longitudinale				
nbarre	φ	d	Asl	
	[mm]	[cm]	[cm ²]	
6,66667	28	6,4	41,05	
6,66667	28	243,6	41,05	
armatura a taglio				
nbracci	φ	s	α	Asw
	[mm]	[cm]	[°]	[cm ²]
3,33333	16	60	90	6,70

- *verifica armature superiore:*

geometria				
sezione trasversale				
B	H	c	d	z
[cm]	[cm]	[cm]	[cm]	[cm]
100	250	5,0	243,6	219,2
armatura longitudinale				
nbarre	φ	d	Asl	
	[mm]	[cm]	[cm ²]	
6,66667	28	6,4	41,05	
6,66667	28	243,6	41,05	
armatura a taglio				
nbracci	φ	s	α	Asw
	[mm]	[cm]	[°]	[cm ²]
3,33333	16	60	90	6,70

sollecitazioni e risultati	
SLE	SLU
MEk 235,00 [kNm]	MEd 1190,00 [kNm]
NEk 0 [kN]	NEd 0 [kN]
tensioni e fessure	
Mdec 0,0 [kNm]	
Mcr 2766,5 [kNm]	
presso-flessione	
	MRd 3841,6 [kNm]
	FS 3,23
taglio	
	VRdc 670,6 [kN]
	predisporre armatura a taglio
	VRds 1659,8 [kN]
	VRdmax 8287,0 [kN]
	θ 30,0 [°]
	sezione duttile
	ai 189,9 [cm]

sollecitazioni e risultati	
SLE	SLU
MEk 169,00 [kNm]	MEd 1014,00 [kNm]
NEk 0 [kN]	NEd 0 [kN]
tensioni e fessure	
Mdec 0,0 [kNm]	
Mcr 2766,5 [kNm]	
presso-flessione	
	MRd 3841,6 [kNm]
	FS 3,79
taglio	
	VRdc 670,6 [kN]
	predisporre armatura a taglio
	VRds 1659,8 [kN]
	VRdmax 8287,0 [kN]
	θ 30,0 [°]
	sezione duttile
	ai 189,9 [cm]

APPALTATORE: Consorzio Soci   	ITINERARIO NAPOLI – BARI RADDOPPIO TRATTA APICE – ORSARA I LOTTO FUNZIONALE APICE – HIRPINIA					
PROGETTAZIONE: Mandataria Mandanti   						
PROGETTO ESECUTIVO RELAZIONE DI CALCOLO FONDAZIONI PILE P1, P2, P21, P22, P23 E P24	COMMESSA IF28	LOTTO 01	CODIFICA E ZZ CL	DOCUMENTO VI0403 002	REV. B	FOGLIO 65 di 161

Sezione 2 trasversale:

- *verifica armature inferiori:*

geometria				
sezione trasversale				
B	H	c	d	z
[cm]	[cm]	[cm]	[cm]	[cm]
100	250	5,0	243,6	219,2
armatura longitudinale				
nbarre	φ	d	Asl	
	[mm]	[cm]	[cm ²]	
6,66667	28	6,4	41,05	
6,66667	28	243,6	41,05	
armatura a taglio				
nbracci	φ	s	α	Asw
	[mm]	[cm]	[°]	[cm ²]
3,33333	16	60	90	6,70

- *verifica armature superiore:*

geometria				
sezione trasversale				
B	H	c	d	z
[cm]	[cm]	[cm]	[cm]	[cm]
100	250	5,0	243,6	219,2
armatura longitudinale				
nbarre	φ	d	Asl	
	[mm]	[cm]	[cm ²]	
6,66667	28	6,4	41,05	
6,66667	28	243,6	41,05	
armatura a taglio				
nbracci	φ	s	α	Asw
	[mm]	[cm]	[°]	[cm ²]
3,33333	16	60	90	6,70

sollecitazioni e risultati	
SLE	SLU
MEk 295,00 [kNm]	MEd 1291,00 [kNm]
NEk 0 [kN]	NEd 0 [kN]
tensioni e fessure	presso-flessione
Mdec 0,0 [kNm]	MRd 3841,6 [kNm]
Mcr 2766,5 [kNm]	FS 2,98
yn -80,48 [cm]	taglio
σ _{c,min} -0,5 [MPa]	VRdc 670,6 [kN]
σ _{s,min} -6,0 [MPa]	predisporre armatura a taglio
σ _{s,max} 31,2 [MPa]	VRds 1659,8 [kN]
k ₂ 0,5	VRdmax 8287,0 [kN]
ε _{sm-ε_{cm}} - [%o]	θ 30,0 [°]
Sr,max - [cm]	sezione duttile
wk - [mm]	ai 189,9 [cm]

sollecitazioni e risultati	
SLE	SLU
MEk 306,00 [kNm]	MEd 1145,00 [kNm]
NEk 0 [kN]	NEd 0 [kN]
tensioni e fessure	presso-flessione
Mdec 0,0 [kNm]	MRd 3841,6 [kNm]
Mcr 2766,5 [kNm]	FS 3,36
yn -80,48 [cm]	taglio
σ _{c,min} -0,5 [MPa]	VRdc 670,6 [kN]
σ _{s,min} -6,2 [MPa]	predisporre armatura a taglio
σ _{s,max} 32,4 [MPa]	VRds 1659,8 [kN]
k ₂ 0,5	VRdmax 8287,0 [kN]
ε _{sm-ε_{cm}} - [%o]	θ 30,0 [°]
Sr,max - [cm]	sezione duttile
wk - [mm]	ai 189,9 [cm]

APPALTATORE: Consorzio Soci   	ITINERARIO NAPOLI – BARI RADDOPPIO TRATTA APICE – ORSARA I LOTTO FUNZIONALE APICE – HIRPINIA					
PROGETTAZIONE: Mandataria Mandanti   						
PROGETTO ESECUTIVO RELAZIONE DI CALCOLO FONDAZIONI PILE P1, P2, P21, P22, P23 E P24	COMMESSA IF28	LOTTO 01	CODIFICA E ZZ CL	DOCUMENTO VI0403 002	REV. B	FOGLIO 66 di 161

Sezione 3 trasversale:

- *verifica armature inferiori:*

geometria				
sezione trasversale				
B	H	c	d	z
[cm]	[cm]	[cm]	[cm]	[cm]
100	250	5,0	243,6	219,2
armatura longitudinale				
nbarre	φ	d	Asl	
	[mm]	[cm]	[cm ²]	
6,66667	28	6,4	41,05	
6,66667	28	243,6	41,05	
armatura a taglio				
nbracci	φ	s	α	Asw
	[mm]	[cm]	[°]	[cm ²]
3,33333	16	60	90	6,70

- *verifica armature superiore:*

geometria				
sezione trasversale				
B	H	c	d	z
[cm]	[cm]	[cm]	[cm]	[cm]
100	250	5,0	243,6	219,2
armatura longitudinale				
nbarre	φ	d	Asl	
	[mm]	[cm]	[cm ²]	
6,66667	28	6,4	41,05	
6,66667	28	243,6	41,05	
armatura a taglio				
nbracci	φ	s	α	Asw
	[mm]	[cm]	[°]	[cm ²]
3,33333	16	60	90	6,70

sollecitazioni e risultati	
SLE	SLU
MEk 440,00 [kNm]	MEd 1523,00 [kNm]
NEk 0 [kN]	NEd 0 [kN]
tensioni e fessure	
Mdec 0,0 [kNm]	
Mcr 2766,5 [kNm]	
yn -80,48 [cm]	
σ _{c,min} -0,7 [MPa]	
σ _{s,min} -8,9 [MPa]	
σ _{s,max} 46,5 [MPa]	
k ₂ 0,5	
ε _{sm-εcm} - [%o]	
Sr,max - [cm]	
Wk - [mm]	
presso-flessione	
MRd 3841,6 [kNm]	
FS 2,52	
taglio	
VRdc 670,6 [kN]	
predisporre armatura a taglio	
VRds 1659,8 [kN]	
VRdmax 8287,0 [kN]	
θ 30,0 [°]	
sezione duttile	
ai 189,9 [cm]	

sollecitazioni e risultati	
SLE	SLU
MEk 774,00 [kNm]	MEd 1944,00 [kNm]
NEk 0 [kN]	NEd 0 [kN]
VEd 1109,00 [kN]	
tensioni e fessure	
Mdec 0,0 [kNm]	
Mcr 2766,5 [kNm]	
yn -80,48 [cm]	
σ _{c,min} -1,2 [MPa]	
σ _{s,min} -15,7 [MPa]	
σ _{s,max} 81,8 [MPa]	
k ₂ 0,5	
ε _{sm-εcm} - [%o]	
Sr,max - [cm]	
Wk - [mm]	
presso-flessione	
MRd 3841,6 [kNm]	
FS 1,98	
taglio	
VRdc 670,6 [kN]	
predisporre armatura a taglio	
VRds 1659,8 [kN]	
VRdmax 8287,0 [kN]	
θ 30,0 [°]	
sezione duttile	
ai 189,9 [cm]	

APPALTATORE: Consorzio Soci   	ITINERARIO NAPOLI – BARI RADDOPPIO TRATTA APICE – ORSARA I LOTTO FUNZIONALE APICE – HIRPINIA					
PROGETTAZIONE: Mandataria Mandanti   						
PROGETTO ESECUTIVO RELAZIONE DI CALCOLO FONDAZIONI PILE P1, P2, P21, P22, P23 E P24	COMMESSA IF28	LOTTO 01	CODIFICA E ZZ CL	DOCUMENTO VI0403 002	REV. B	FOGLIO 67 di 161

Sezione 4 trasversale:

- *verifica armature inferiori:*

geometria				
sezione trasversale				
B	H	c	d	z
[cm]	[cm]	[cm]	[cm]	[cm]
100	250	5,0	243,6	219,2
armatura longitudinale				
nbarre	φ	d	Asl	
	[mm]	[cm]	[cm ²]	
6,66667	28	6,4	41,05	
6,66667	28	243,6	41,05	
armatura a taglio				
nbracci	φ	s	α	Asw
	[mm]	[cm]	[°]	[cm ²]
3,33333	16	30	90	6,70

- *verifica armature superiore:*

geometria				
sezione trasversale				
B	H	c	d	z
[cm]	[cm]	[cm]	[cm]	[cm]
100	250	5,0	243,6	219,2
armatura longitudinale				
nbarre	φ	d	Asl	
	[mm]	[cm]	[cm ²]	
6,66667	28	6,4	41,05	
6,66667	28	243,6	41,05	
armatura a taglio				
nbracci	φ	s	α	Asw
	[mm]	[cm]	[°]	[cm ²]
3,33333	16	30	90	6,70

sollecitazioni e risultati	
SLE	SLU
MEk 810,00 [kNm]	MEd 2115,00 [kNm]
NEk 0 [kN]	NEd 0 [kN]
tensioni e fessure	presso-flessione
Mdec 0,0 [kNm]	MRd 3841,6 [kNm]
Mcr 2766,5 [kNm]	FS 1,82
yn -80,48 [cm]	taglio
σ _{c,min} -1,3 [MPa]	VRdc 670,6 [kN]
σ _{s,min} -16,4 [MPa]	predisporre armatura a taglio
σ _{s,max} 85,7 [MPa]	VRds 3319,6 [kN]
k ₂ 0,5	VRdmax 8287,0 [kN]
ε _{sm-εcm} - [%o]	θ 30,0 [°]
Sr,max - [cm]	sezione duttile
wk - [mm]	ai 189,9 [cm]

sollecitazioni e risultati	
SLE	SLU
MEk 1338,00 [kNm]	MEd 2923,00 [kNm]
NEk 0 [kN]	NEd 0 [kN]
tensioni e fessure	presso-flessione
Mdec 0,0 [kNm]	MRd 3841,6 [kNm]
Mcr 2766,5 [kNm]	FS 1,31
yn -80,48 [cm]	taglio
σ _{c,min} -2,1 [MPa]	VRdc 670,6 [kN]
σ _{s,min} -27,1 [MPa]	predisporre armatura a taglio
σ _{s,max} 141,5 [MPa]	VRds 3319,6 [kN]
k ₂ 0,5	VRdmax 8287,0 [kN]
ε _{sm-εcm} - [%o]	θ 30,0 [°]
Sr,max - [cm]	sezione duttile
wk - [mm]	ai 189,9 [cm]

APPALTATORE: Consorzio Soci   	ITINERARIO NAPOLI – BARI RADDOPPIO TRATTA APICE – ORSARA I LOTTO FUNZIONALE APICE – HIRPINIA					
PROGETTAZIONE: Mandataria Mandanti   						
PROGETTO ESECUTIVO RELAZIONE DI CALCOLO FONDAZIONI PILE P1, P2, P21, P22, P23 E P24	COMMESSA IF28	LOTTO 01	CODIFICA E ZZ CL	DOCUMENTO VI0403 002	REV. B	FOGLIO 68 di 161

Sezione 5 trasversale:

- *verifica armature inferiori:*

geometria				
sezione trasversale				
B	H	c	d	z
[cm]	[cm]	[cm]	[cm]	[cm]
100	250	5,0	240,8	216,7
armatura longitudinale				
nbarre	φ	d	Asl	
	[mm]	[cm]	[cm ²]	
13,3333	28	6,4	82,10	
13,3333	28	238,0	82,10	
13,3333	28	243,6	82,10	
armatura a taglio				
nbracci	φ	s	α	Asw
	[mm]	[cm]	[°]	[cm ²]
3,33333	16	15	90	6,70

- *verifica armature superiore:*

geometria				
sezione trasversale				
B	H	c	d	z
[cm]	[cm]	[cm]	[cm]	[cm]
100	250	5,0	240,8	216,7
armatura longitudinale				
nbarre	φ	d	Asl	
	[mm]	[cm]	[cm ²]	
13,3333	28	6,4	82,10	
13,3333	28	238,0	82,10	
13,3333	28	243,6	82,10	
armatura a taglio				
nbracci	φ	s	α	Asw
	[mm]	[cm]	[°]	[cm ²]
3,33333	16	15	90	6,70

sollecitazioni e risultati	
SLE	SLU
MEk 1880,00 [kNm]	MEd 5430,00 [kNm]
NEk 0 [kN]	NEd 0 [kN]
tensioni e fessure	
Mdec 0,0 [kNm]	
Mcr 3464,8 [kNm]	
yn -46,25 [cm]	
σc,min -1,7 [MPa]	
σs,min -23,3 [MPa]	
σs,max 53,2 [MPa]	
k2 0,5	
εsm-εcm - [%o]	
Sr,max - [cm]	
wk - [mm]	
presso-flessione	
MRd 14918,6 [kNm]	
FS 2,75	
taglio	
VRdc 1007,2 [kN]	
predisporre armatura a taglio	
VRds 6562,8 [kN]	
VRdmax 8191,8 [kN]	
θ 30,0 [°]	
sezione duttile	
ai 187,7 [cm]	

sollecitazioni e risultati	
SLE	SLU
MEk 3846,00 [kNm]	MEd 7363,00 [kNm]
NEk 0 [kN]	NEd 0 [kN]
tensioni e fessure	
Mdec 0,0 [kNm]	
Mcr 3464,8 [kNm]	
yn -46,25 [cm]	
σc,min -1,7 [MPa]	
σs,min -23,3 [MPa]	
σs,max 53,2 [MPa]	
k2 0,5	
εsm-εcm - [%o]	
Sr,max - [cm]	
wk - [mm]	
presso-flessione	
MRd 14918,6 [kNm]	
FS 2,75	
taglio	
VRdc 1007,2 [kN]	
predisporre armatura a taglio	
VRds 6562,8 [kN]	
VRdmax 8191,8 [kN]	
θ 30,0 [°]	
sezione duttile	
ai 187,7 [cm]	

APPALTATORE: Consorzio Soci   	ITINERARIO NAPOLI – BARI RADDOPPIO TRATTA APICE – ORSARA I LOTTO FUNZIONALE APICE – HIRPINIA					
PROGETTAZIONE: Mandataria Mandanti   						
PROGETTO ESECUTIVO RELAZIONE DI CALCOLO FONDAZIONI PILE P1, P2, P21, P22, P23 E P24	COMMESSA IF28	LOTTO 01	CODIFICA E ZZ CL	DOCUMENTO VI0403 002	REV. B	FOGLIO 69 di 161

Sezione 6 trasversale:

- *verifica armature inferiori:*

geometria				
sezione trasversale				
B	H	c	d	z
[cm]	[cm]	[cm]	[cm]	[cm]
100	250	5,0	243,6	219,2
armatura longitudinale				
nbarre	φ	d	Asl	
	[mm]	[cm]	[cm ²]	
6,66667	28	6,4	41,05	
6,66667	28	243,6	41,05	
armatura a taglio				
nbracci	φ	s	α	Asw
	[mm]	[cm]	[°]	[cm ²]
3,33333	16	30	90	6,70

- *verifica armature superiore:*

geometria				
sezione trasversale				
B	H	c	d	z
[cm]	[cm]	[cm]	[cm]	[cm]
100	250	5,0	243,6	219,2
armatura longitudinale				
nbarre	φ	d	Asl	
	[mm]	[cm]	[cm ²]	
6,66667	28	6,4	41,05	
6,66667	28	243,6	41,05	
armatura a taglio				
nbracci	φ	s	α	Asw
	[mm]	[cm]	[°]	[cm ²]
3,33333	16	30	90	6,70

sollecitazioni e risultati	
SLE	SLU
MEk 680,00 [kNm]	MEd 1609,00 [kNm]
NEk 0 [kN]	NEd 0 [kN]
tensioni e fessure	
Mdec 0,0 [kNm]	
Mcr 2766,5 [kNm]	
yn -80,48 [cm]	
σ _{c,min} -1,1 [MPa]	
σ _{s,min} -13,8 [MPa]	
σ _{s,max} 71,9 [MPa]	
k ₂ 0,5	
ε _{sm} -ε _{cm} - [%o]	
S _{r,max} - [cm]	
w _k - [mm]	
presso-flessione	
MRd 3841,6 [kNm]	
FS 2,39	
taglio	
VRdc 670,6 [kN]	
predisporre armatura a taglio	
VRds 3319,6 [kN]	
VRdmax 8287,0 [kN]	
θ 30,0 [°]	
sezione duttile	
ai 189,9 [cm]	

sollecitazioni e risultati	
SLE	SLU
MEk 720,00 [kNm]	MEd 1746,00 [kNm]
NEk 0 [kN]	NEd 0 [kN]
tensioni e fessure	
Mdec 0,0 [kNm]	
Mcr 2766,5 [kNm]	
yn -80,48 [cm]	
σ _{c,min} -1,1 [MPa]	
σ _{s,min} -14,6 [MPa]	
σ _{s,max} 76,1 [MPa]	
k ₂ 0,5	
ε _{sm} -ε _{cm} - [%o]	
S _{r,max} - [cm]	
w _k - [mm]	
presso-flessione	
MRd 3841,6 [kNm]	
FS 2,20	
taglio	
VRdc 670,6 [kN]	
predisporre armatura a taglio	
VRds 3319,6 [kN]	
VRdmax 8287,0 [kN]	
θ 30,0 [°]	
sezione duttile	
ai 189,9 [cm]	

APPALTATORE: Consorzio  Soci  	ITINERARIO NAPOLI – BARI RADDOPPIO TRATTA APICE – ORSARA I LOTTO FUNZIONALE APICE – HIRPINIA					
PROGETTAZIONE: Mandataria  Mandanti  						
PROGETTO ESECUTIVO RELAZIONE DI CALCOLO FONDAZIONI PILE P1, P2, P21, P22, P23 E P24	COMMESSA IF28	LOTTO 01	CODIFICA E ZZ CL	DOCUMENTO VI0403 002	REV. B	FOGLIO 70 di 161

10.4 VERIFICA PUNZONAMENTO

La verifica a punzonamento viene eseguita in prima istanza trascurando la presenza di armatura e considerando l'azione assiale massima di compressione agente sui pali e ipotizzando di questa sia riferita ad un palo di bordo.

La verifica è eseguita sul perimetro del palo, u_0 , e sul perimetro composto dal quadrato di lato 3,75m che traccia l'interasse tra i pali, u_1 .

- Verifica su u_0 :

$$v_{ED,0} = \frac{\beta N_{ED}}{u_0 H} \leq v_{RD,max} = 0,5 v f_{cd}$$

- Verifica su u_1 :

$$v_{ED,1} = \frac{N_{ED}}{u_1 H} \leq v_{RD,max} = 0,5 f_{ctd}$$

Caratteristiche meccaniche			
R_{ck}	resistenza cubica a compressione caratteristica	35	MPa
f_{ck}	resistenza cilindrica a compressione caratteristica	29,1	MPa
f_{cd}	resistenza cilindrica a compressione di progetto	16,5	MPa
f_{ctd}	resistenza cilindrica a trazione di progetto	1,32	MPa
v	$0,6 \times (1 - f_{ck} / 250)$	0,53	[-]
Caratteristiche geometriche			
D_{palo}	diametro palo	1,5	m
u_0	perimetro palo	4,7	m
H_{plinto}	altezza plinto	2,5	m
u_1	perimetro interno posto ad interasse pali di bordo	7,5	m
β	fattore di posizione del palo	1,5	[-]
Sollecitazione			
N_{Ed}	azione assiale sollecitante	10151,0	kN
Verifica su u_0			
$V_{Ed,0}$	sforzo agente su u_0	1,29	MPa
$V_{Rd,0}$	sforzo resistente su u_0	4,36	MPa
FS	fattore di sicurezza	3,38	[-]
Verifica su u_1			
$V_{Ed,1}$	sforzo agente su u_1	0,54	MPa
$V_{Rd,1}$	sforzo resistente su u_1	0,66	MPa
FS	fattore di sicurezza	1,22	[-]

Tale verifica risulta soddisfatta nelle condizioni esplicitate, quindi non viene eseguita la verifica considerando la presenza di armatura e l'effettiva posizione del palo.

APPALTATORE: Consorzio Soci   	ITINERARIO NAPOLI – BARI RADDOPPIO TRATTA APICE – ORSARA I LOTTO FUNZIONALE APICE – HIRPINIA																	
PROGETTAZIONE: Mandataria Mandanti   	<table border="1" style="width: 100%; border-collapse: collapse;"> <tr> <td style="width: 16.6%;">COMMESSA</td> <td style="width: 16.6%;">LOTTO</td> <td style="width: 16.6%;">CODIFICA</td> <td style="width: 16.6%;">DOCUMENTO</td> <td style="width: 16.6%;">REV.</td> <td style="width: 16.6%;">FOGLIO</td> </tr> <tr> <td>IF28</td> <td>01</td> <td>E ZZ CL</td> <td>VI0403 002</td> <td>B</td> <td>71 di 161</td> </tr> </table>						COMMESSA	LOTTO	CODIFICA	DOCUMENTO	REV.	FOGLIO	IF28	01	E ZZ CL	VI0403 002	B	71 di 161
COMMESSA	LOTTO	CODIFICA	DOCUMENTO	REV.	FOGLIO													
IF28	01	E ZZ CL	VI0403 002	B	71 di 161													
PROGETTO ESECUTIVO RELAZIONE DI CALCOLO FONDAZIONI PILE P1, P2, P21, P22, P23 E P24																		

10.5 VERIFICA TIRANTE-PUNTONE

Data la disposizione dei pali e la geometria della platea tale meccanismo non è ritenuto applicabile, in quanto:

- i pali più lontani dai setti della pila sono a una distanza tale per cui il meccanismo resistente è quello flessionale;
- i pali più vicini ai setti della pila sono quasi perpendicolari alla stessa.

Il meccanismo resistente con cui è stata dimensionata la platea di fondazione è un meccanismo flessionale, quindi, per questa geometria, la verifica tirante-puntone non è stata eseguita.

10.6 STIMA INCIDENZE DI ARMATURA

Per la stima delle incidenze di armatura dei plinti di fondazione si rimanda al Viadotto VI01 che presenta configurazione di carichi e geometrie assimilabili a quelle in oggetto.

APPALTATORE: Consorzio Soci 	ITINERARIO NAPOLI – BARI RADDOPPIO TRATTA APICE – ORSARA I LOTTO FUNZIONALE APICE – HIRPINIA																	
PROGETTAZIONE: Mandataria Mandanti 							<table border="1" style="width: 100%; border-collapse: collapse;"> <tr> <td style="width: 16.6%;">COMMESSA</td> <td style="width: 16.6%;">LOTTO</td> <td style="width: 16.6%;">CODIFICA</td> <td style="width: 16.6%;">DOCUMENTO</td> <td style="width: 16.6%;">REV.</td> <td style="width: 16.6%;">FOGLIO</td> </tr> <tr> <td>IF28</td> <td>01</td> <td>E ZZ CL</td> <td>VI0403 002</td> <td>B</td> <td>72 di 161</td> </tr> </table>						COMMESSA	LOTTO	CODIFICA	DOCUMENTO	REV.	FOGLIO
COMMESSA	LOTTO	CODIFICA	DOCUMENTO	REV.	FOGLIO													
IF28	01	E ZZ CL	VI0403 002	B	72 di 161													

11 DIMENSIONAMENTO E VERIFICA DEL PLINTO DI FONDAZIONE [P2]

11.1 DESCRIZIONE DEL MODELLO

La platea di fondazione ha le seguenti dimensioni 16 m x 12 m x 2,5 m, con un ricoprimento minimo di 2,1 m; la platea presenta 12 pali.

Il dimensionamento a flessione e taglio del plinto di fondazione viene fatta a filo della pila, in modo da valutare le massime sollecitazioni, **Figura 10.1**.



Figura 11.1 Pianta del plinto

La platea di fondazione è stata modellata mediante il software SAP2000, con elementi shell.

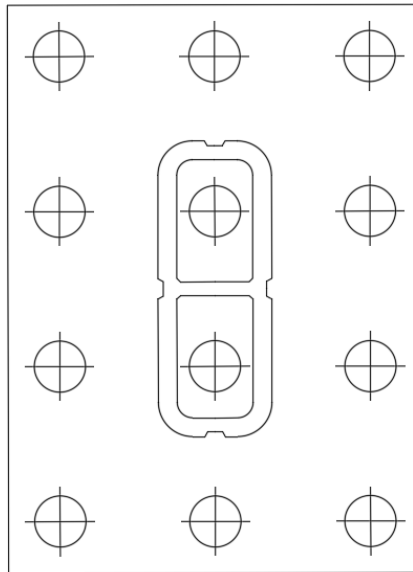

Figura 11.2 Modello numerico

APPALTATORE: Consorzio Soci   	ITINERARIO NAPOLI – BARI RADDOPPIO TRATTA APICE – ORSARA I LOTTO FUNZIONALE APICE – HIRPINIA																	
PROGETTAZIONE: Mandataria Mandanti   	<table border="1" style="width: 100%; border-collapse: collapse;"> <tr> <td style="width: 16.6%;">COMMESSA</td> <td style="width: 16.6%;">LOTTO</td> <td style="width: 16.6%;">CODIFICA</td> <td style="width: 16.6%;">DOCUMENTO</td> <td style="width: 16.6%;">REV.</td> <td style="width: 16.6%;">FOGLIO</td> </tr> <tr> <td>IF28</td> <td>01</td> <td>E ZZ CL</td> <td>VI0403 002</td> <td>B</td> <td>73 di 161</td> </tr> </table>						COMMESSA	LOTTO	CODIFICA	DOCUMENTO	REV.	FOGLIO	IF28	01	E ZZ CL	VI0403 002	B	73 di 161
COMMESSA	LOTTO	CODIFICA	DOCUMENTO	REV.	FOGLIO													
IF28	01	E ZZ CL	VI0403 002	B	73 di 161													
PROGETTO ESECUTIVO RELAZIONE DI CALCOLO FONDAZIONI PILE P1, P2, P21, P22, P23 E P24																		

A partire dalle azioni interne delle fondazioni profonde, definiti precedentemente, è stato possibile caricare la platea in esame, considerando il carico concentrato proveniente dalle differenti combinazioni per ogni palo nel proprio baricentro.

La platea è stata vincolata in corrispondenza del fusto pila attraverso dei vincoli traslazionali che non interrompono la continuità del momento, **Figura 10.3**.

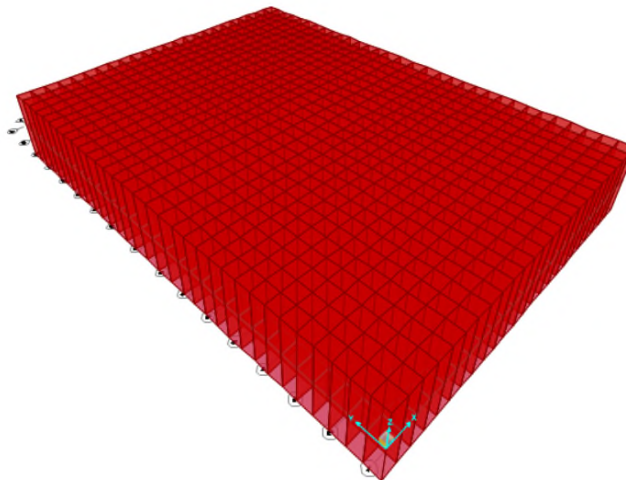

Figura 11.3 Modello numerico con le condizioni al contorno

11.1.1 Combinazioni e carichi





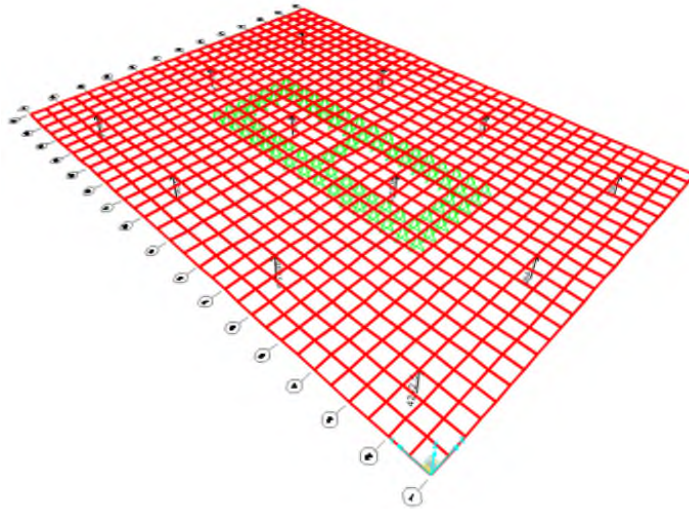

Le combinazioni introdotte nel modello numerico ad elementi finiti sono caratterizzate da non avere coefficienti di amplificazione per i vari Stati Limite, in quanto gli scarichi dei pali considerano già tale amplificazione.

Sono state considerate:

- 10 Combinazioni SLV, stato limite di salvaguardia della vita;
- 6 Combinazioni SLU, stato limite ultimo;
- 4 Combinazioni SLE-R, stato limite di esercizio caratteristico.

Gli scarichi sui pali sono stati quelli determinati attraverso il software Group come definito al paragrafo 7.1.

Ai carichi sopra citati, viene aggiunto il carico distribuito dato dal terreno di ricoprimento minimo, considerando tale carico permanente non strutturale.

APPALTATORE: Consorzio Soci   	ITINERARIO NAPOLI – BARI					
PROGETTAZIONE: Mandataria Mandanti   	RADDOPPIO TRATTA APICE – ORSARA I LOTTO FUNZIONALE APICE – HIRPINIA					
PROGETTO ESECUTIVO RELAZIONE DI CALCOLO FONDAZIONI PILE P1, P2, P21, P22, P23 E P24	COMMESSA IF28	LOTTO 01	CODIFICA E ZZ CL	DOCUMENTO VI0403 002	REV. B	FOGLIO 74 di 161

11.2 SOLLECITAZIONI

11.2.1 Sollecitazioni SLV



Figura 11.4 M11 max SLV



Figura 11.5 M11 min SLV

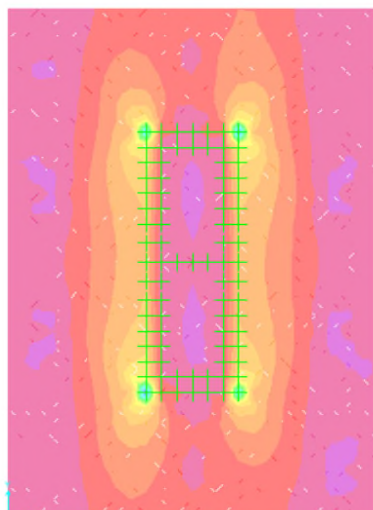

Figura 11.6 M22 max SLV

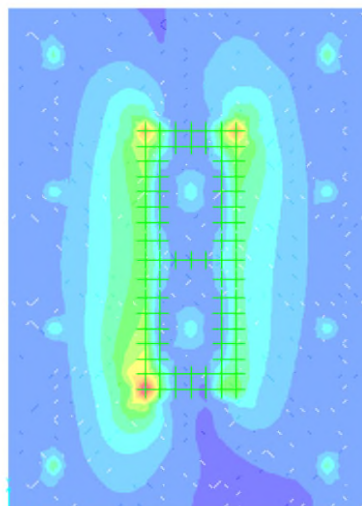
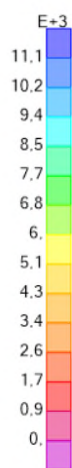

Figura 11.7 M22 min SLV

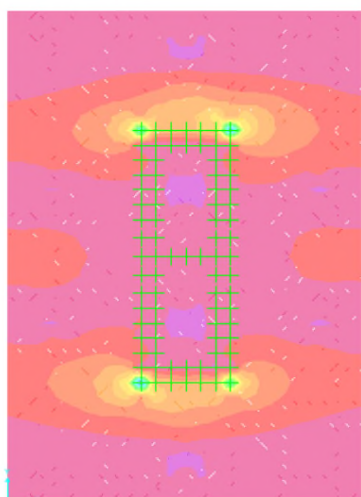

APPALTATORE:

Consorzio

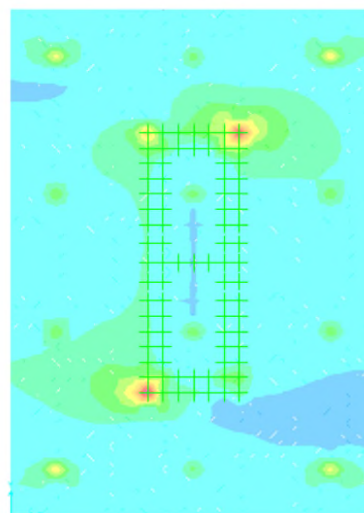
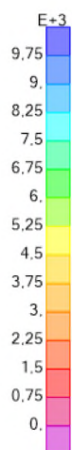
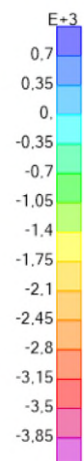
Soci



PROGETTAZIONE:

Mandataria

Mandanti



PROGETTO ESECUTIVO

RELAZIONE DI CALCOLO FONDAZIONI PILE P1, P2, P21, P22, P23 E P24

ITINERARIO NAPOLI – BARI

RADDOPPIO TRATTA APICE – ORSARA
I LOTTO FUNZIONALE APICE – HIRPINIA

COMMESSA
IF28

LOTTO
01

CODIFICA
E ZZ CL

DOCUMENTO
VI0403 002

REV.
B

FOGLIO
75 di 161



Figura 11.8 M12 max SLV



Figura 11.9 M12 min SLV

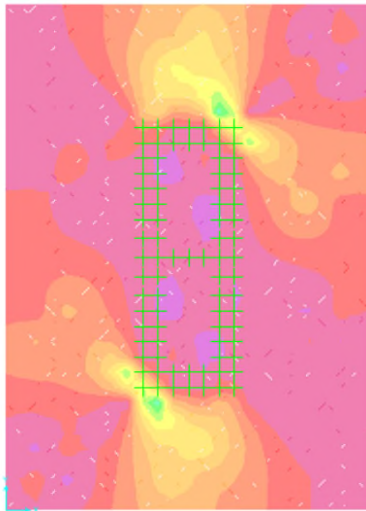

Figura 11.10 V13 max SLV

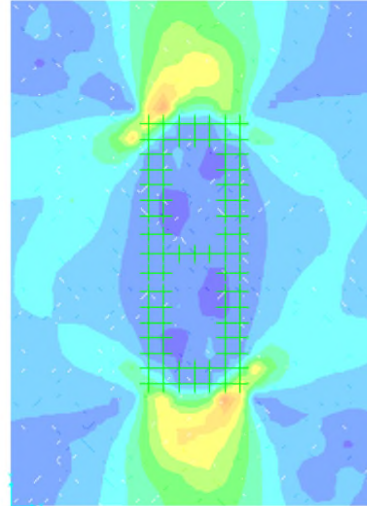

Figura 11.11 V13 min SLV

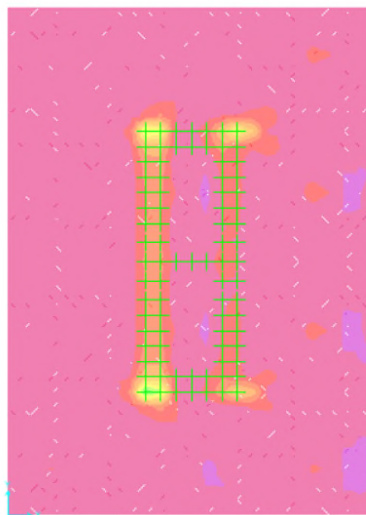
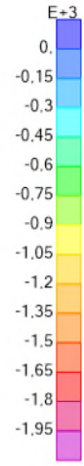

APPALTATORE:

Consorzio

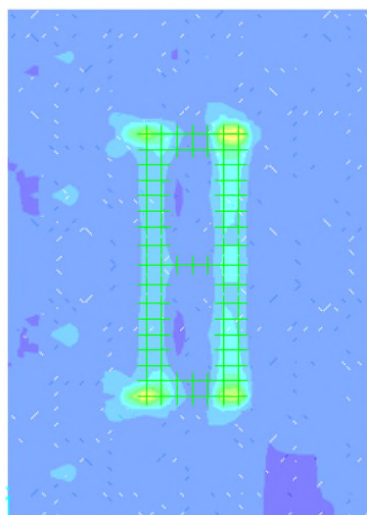
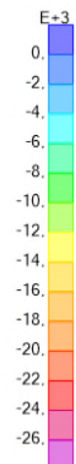

Soci



PROGETTAZIONE:

Mandataria



Mandanti



ITINERARIO NAPOLI – BARI

RADDOPPIO TRATTA APICE – ORSARA
I LOTTO FUNZIONALE APICE – HIRPINIA

PROGETTO ESECUTIVO

RELAZIONE DI CALCOLO FONDAZIONI PILE P1, P2, P21, P22, P23
E P24

COMMESSA
IF28

LOTTO
01

CODIFICA
E ZZ CL

DOCUMENTO
VI0403 002

REV.
B

FOGLIO
76 di 161



Figura 11.12 V23 max SLV



Figura 11.13 V23 min SLV

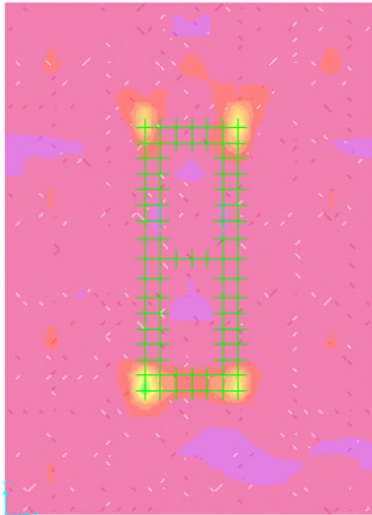

11.2.2 Sollecitazioni SLU

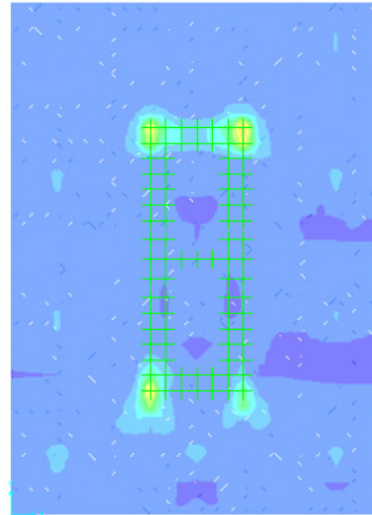

Figura 11.14 M11 max SLU



Figura 11.15 M11 min SLU

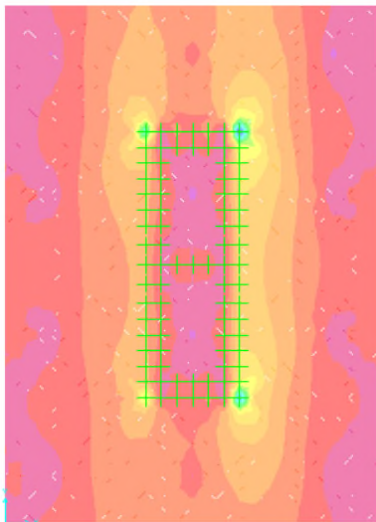

APPALTATORE:

Consorzio

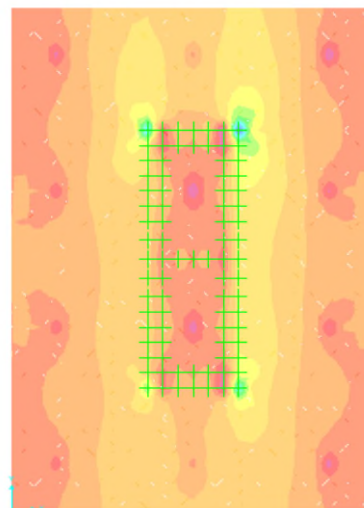
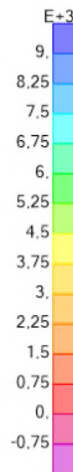
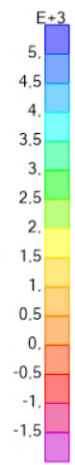
Soci



PROGETTAZIONE:

Mandataria

Mandanti



ITINERARIO NAPOLI – BARI

RADDOPPIO TRATTA APICE – ORSARA
I LOTTO FUNZIONALE APICE – HIRPINIA

PROGETTO ESECUTIVO

RELAZIONE DI CALCOLO FONDAZIONI PILE P1, P2, P21, P22, P23
E P24

COMMESSA
IF28

LOTTO
01

CODIFICA
E ZZ CL

DOCUMENTO
VI0403 002

REV.
B

FOGLIO
77 di 161



Figura 11.16 M22 max SLU



Figura 11.17 M22 min SLU

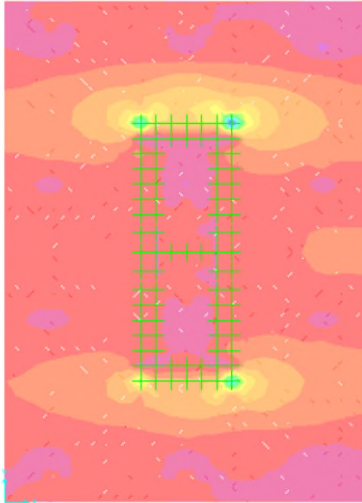

Figura 11.18 M12 max SLU

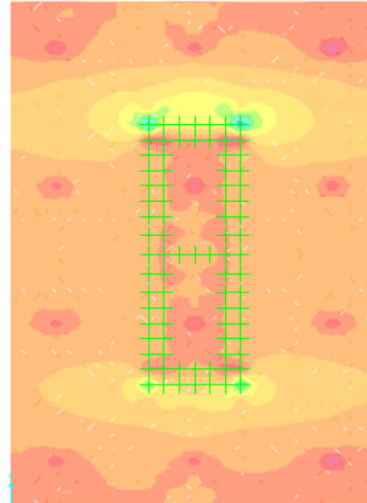

Figura 11.19 M12 min SLU

APPALTATORE:

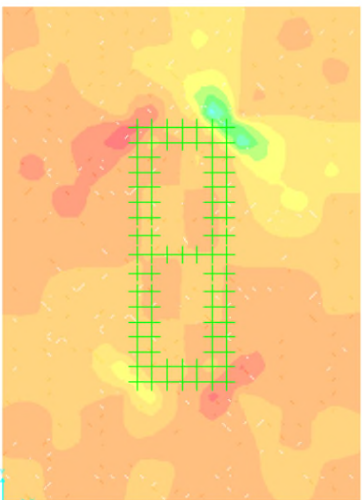
Consorzio

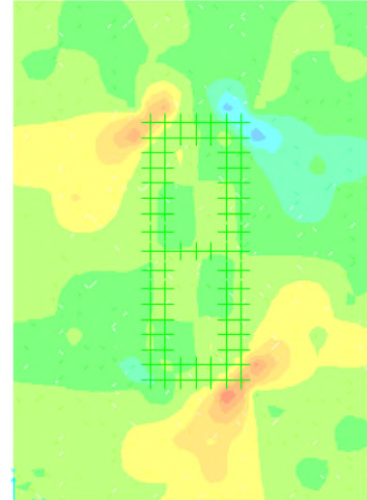

Soci



PROGETTAZIONE:

Mandataria



Mandanti



ITINERARIO NAPOLI – BARI

RADDOPPIO TRATTA APICE – ORSARA
I LOTTO FUNZIONALE APICE – HIRPINIA

PROGETTO ESECUTIVO

RELAZIONE DI CALCOLO FONDAZIONI PILE P1, P2, P21, P22, P23
E P24

COMMESSA
IF28

LOTTO
01

CODIFICA
E ZZ CL

DOCUMENTO
VI0403 002

REV.
B

FOGLIO
78 di 161



Figura 11.20 V13 max SLU



Figura 11.21 V13 min SLU

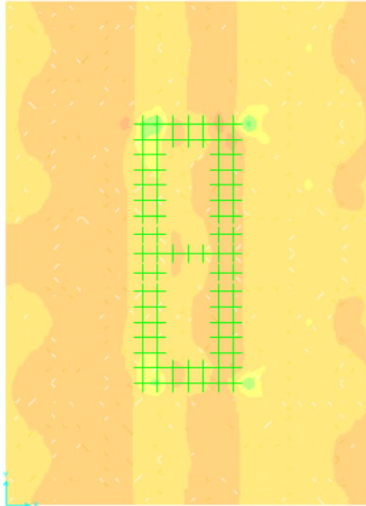

Figura 11.22 V23 max SLU



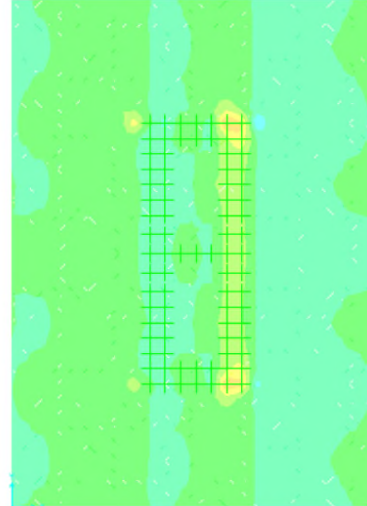
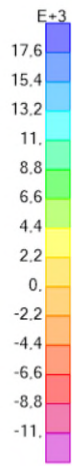



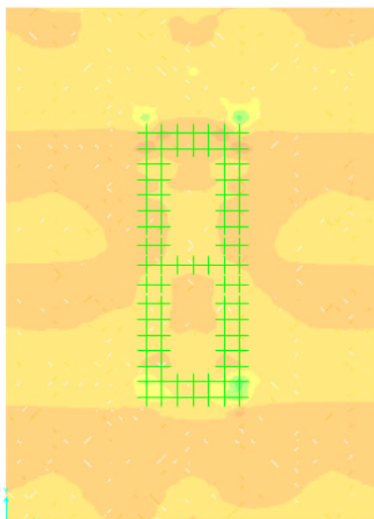

Figura 11.23 V23 min SLU

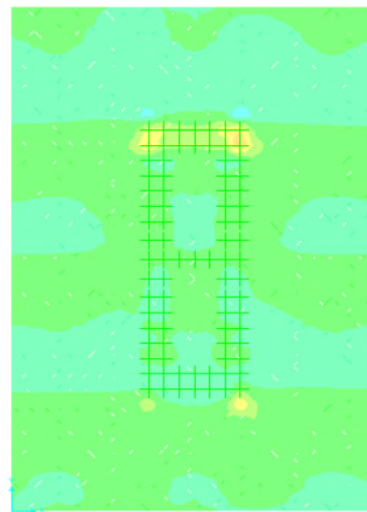
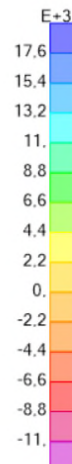
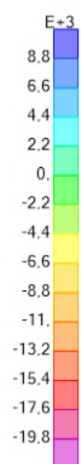

APPALTATORE: Consorzio Soci   		ITINERARIO NAPOLI – BARI RADDOPPIO TRATTA APICE – ORSARA I LOTTO FUNZIONALE APICE – HIRPINIA					
PROGETTAZIONE: Mandataria Mandanti   		COMMESSA	LOTTO	CODIFICA	DOCUMENTO	REV.	FOGLIO
PROGETTO ESECUTIVO RELAZIONE DI CALCOLO FONDAZIONI PILE P1, P2, P21, P22, P23 E P24		IF28	01	E ZZ CL	VI0403 002	B	79 di 161

11.2.3 Sollecitazioni SLE



Figura 11.24 M11 max SLE



Figura 11.25 M11 min SLE

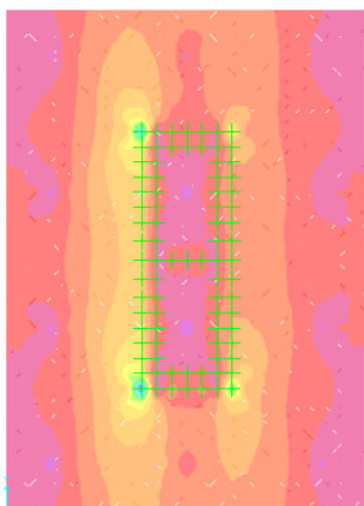

Figura 11.26 M22 max SLE



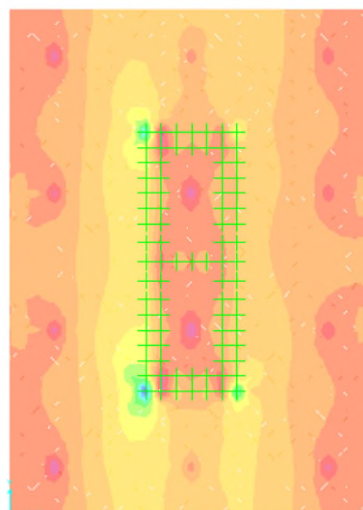



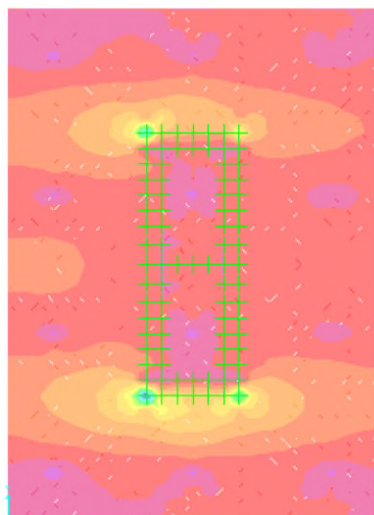

Figura 11.27 M22 min SLE

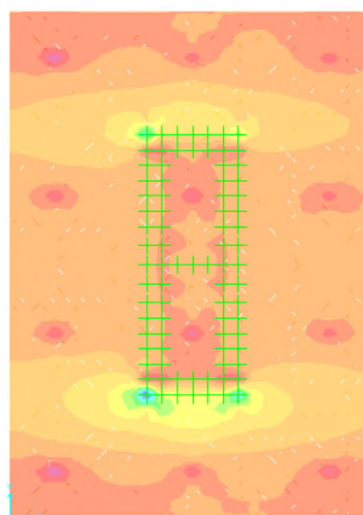
APPALTATORE: Consorzio Soci   	ITINERARIO NAPOLI – BARI RADDOPPIO TRATTA APICE – ORSARA I LOTTO FUNZIONALE APICE – HIRPINIA																	
PROGETTAZIONE: Mandataria Mandanti   	<table border="1" style="width: 100%; border-collapse: collapse;"> <tr> <td style="width: 16.6%;">COMMESSA</td> <td style="width: 16.6%;">LOTTO</td> <td style="width: 16.6%;">CODIFICA</td> <td style="width: 16.6%;">DOCUMENTO</td> <td style="width: 16.6%;">REV.</td> <td style="width: 16.6%;">FOGLIO</td> </tr> <tr> <td>IF28</td> <td>01</td> <td>E ZZ CL</td> <td>VI0403 002</td> <td>B</td> <td>80 di 161</td> </tr> </table>						COMMESSA	LOTTO	CODIFICA	DOCUMENTO	REV.	FOGLIO	IF28	01	E ZZ CL	VI0403 002	B	80 di 161
COMMESSA	LOTTO	CODIFICA	DOCUMENTO	REV.	FOGLIO													
IF28	01	E ZZ CL	VI0403 002	B	80 di 161													
PROGETTO ESECUTIVO RELAZIONE DI CALCOLO FONDAZIONI PILE P1, P2, P21, P22, P23 E P24																		



Figura 11.28 M12 max SLE



Figura 11.29 M12 min SLE

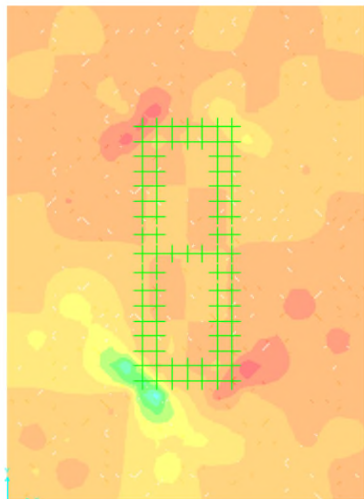

APPALTATORE: Consorzio Soci 	ITINERARIO NAPOLI – BARI RADDOPPIO TRATTA APICE – ORSARA I LOTTO FUNZIONALE APICE – HIRPINIA																	
PROGETTAZIONE: Mandataria Mandanti 							<table border="1" style="width: 100%; border-collapse: collapse;"> <tr> <td style="width: 16.6%;">COMMESSA</td> <td style="width: 16.6%;">LOTTO</td> <td style="width: 16.6%;">CODIFICA</td> <td style="width: 16.6%;">DOCUMENTO</td> <td style="width: 16.6%;">REV.</td> <td style="width: 16.6%;">FOGLIO</td> </tr> <tr> <td>IF28</td> <td>01</td> <td>E ZZ CL</td> <td>VI0403 002</td> <td>B</td> <td>81 di 161</td> </tr> </table>						COMMESSA	LOTTO	CODIFICA	DOCUMENTO	REV.	FOGLIO
COMMESSA	LOTTO	CODIFICA	DOCUMENTO	REV.	FOGLIO													
IF28	01	E ZZ CL	VI0403 002	B	81 di 161													

11.3 VERIFICHE SLU/SLE

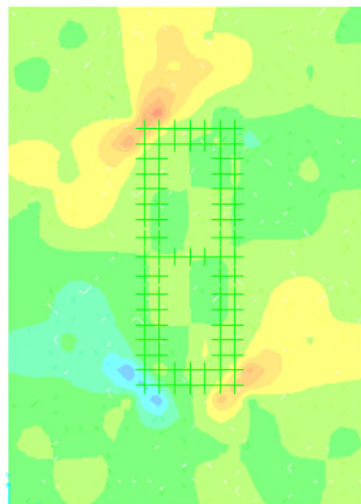
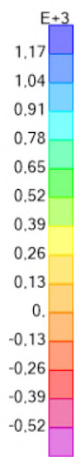
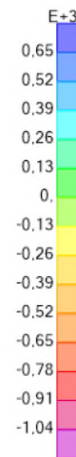
11.3.1 Sollecitazioni di verifica

A partire dallo stato di sollecitazione determinato attraverso il software, sono state definite section-cut di 1m sul filo della pila nelle due direzioni.

La definizione delle section-cut permette attraverso il post-processing definire la sollecitazione media su un metro di piastra, ciò al fine di by-passare la concentrazione delle azioni su porzioni infinitesime di piastra, che sono dovuti alla schematizzazione dei vincoli come puntuali.

Quindi le azioni interne sono definite secondo sezioni come indicato nelle seguenti immagini:



Figura 11.30 Definizione delle Section-cut

A partire dalle azioni così definite è possibile involuppare geometricamente secondo i due assi di simmetria del plinto di fondazione in modo da garantire la copertura massima delle azioni sollecitanti, in aggiunta ad uno schema d'armatura doppiamente simmetrico.

APPALTATORE: Consorzio  Soci  	ITINERARIO NAPOLI – BARI RADDOPPIO TRATTA APICE – ORSARA I LOTTO FUNZIONALE APICE – HIRPINIA					
PROGETTAZIONE: Mandataria  Mandanti  						
PROGETTO ESECUTIVO RELAZIONE DI CALCOLO FONDAZIONI PILE P1, P2, P21, P22, P23 E P24	COMMESSA IF28	LOTTO 01	CODIFICA E ZZ CL	DOCUMENTO VI0403 002	REV. B	FOGLIO 82 di 161

Di seguito sono riportati i vari involuipi geometrici:

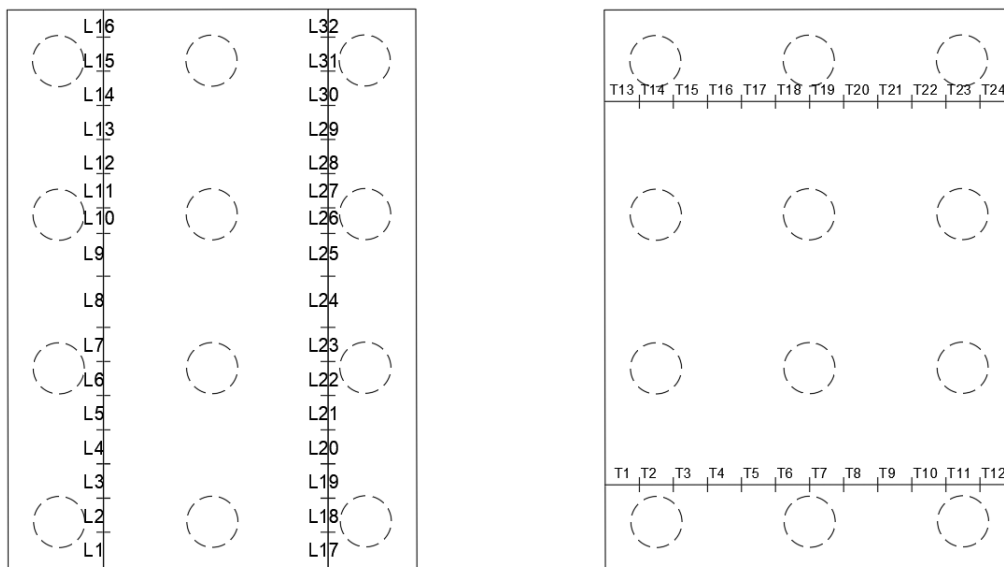
Longitudinale	Trasversale
Max (L1, L16, L17, L32)	Max (T1, T12, T13, T24)
Max (L2, L15, L18, L31)	Max (T2, T11, T14, T23)
Max (L3, L14, L19, L30)	Max (T3, T10, T15, T22)
Max (L4, L13, L20, L29)	Max (T4, T9, T16, T21)
Max (L5, L12, L21, L28)	Max (T5, T8, T17, T20)
Max (L6, L11, L22, L27)	Max (T6, T7, T18, T19)
Max (L7, L10, L23, L26)	
Max (L8, L9, L24, L25)	

Il momento torcente è stato sommato in modulo a fine di massimizzare l'effetto della flessione.

Di seguito sono riportate le sollecitazioni ai vari stati limite.

	EnvSLV	M		V		
		min	max	min	max	
	Longitudinale	1	-2722,85	1449,795	-348,226	
	2	-3172,03	1859,523	-424,855	212,325	max(L2,L15,L18,L31)
	3	-4060,78	2432,463	-908,912	401,481	max(L3,L14,L19,L30)
	4	-4243,63	2479,863	-2366,15	4505,665	max(L4,L13,L20,L29)
	5	-7992,57	4656,566	-2696,06	3768,285	max(L5,L12,L21,L28)
	6	-4615,38	2290,941	-1194,28	715,948	max(L6,L11,L22,L27)
	7	-3701,29	1885,469	-855,266	682,461	max(L7,L10,L23,L26)
	8	-4072,46	2139,538	-1020,44	890,914	max(L8,L19,L24,L25)

	EnvSLV	M		V		
		min	max	min	max	
	Trasversale	1	-649,688	1747,348	-510,844	
	2	-779,452	2036,17	-542,944	282,135	max(T2,T15,T18,T31)
	3	-1014,04	2554,948	-811,645	441,852	max(T3,T14,T19,T30)
	4	-2726,91	3419,555	-2101,85	1080,9	max(T4,T13,T20,T29)
	5	-2709,74	5839,505	-2931,27	7069,852	max(T5,T12,T21,T28)
	6	-2314,57	5180,383	-1560,74	534,271	max(T6,T11,T22,T27)

APPALTATORE: Consorzio  Soci  		ITINERARIO NAPOLI – BARI RADDOPPIO TRATTA APICE – ORSARA I LOTTO FUNZIONALE APICE – HIRPINIA					
PROGETTAZIONE: Mandataria  Mandanti  							
PROGETTO ESECUTIVO RELAZIONE DI CALCOLO FONDAZIONI PILE P1, P2, P21, P22, P23 E P24		COMMESSA IF28	LOTTO 01	CODIFICA E ZZ CL	DOCUMENTO VI0403 002	REV. B	FOGLIO 83 di 161

	EnvSLU	M		V		
		min	max	min	max	
	Longitudinale	1	-2113,61	-1029,61	-342,207	
	2	-2296,21	-1109,76	-407,232	137,057	max(L2,L15,L18,L31)
	3	-2691,32	-1208,59	-847,128	107,61	max(L3,L14,L19,L30)
	4	-3713,22	-1366,63	-2142,22	3137,004	max(L4,L13,L20,L29)
	5	-5691,78	-1825,9	-2372,97	2014,773	max(L5,L12,L21,L28)
	6	-3978,29	-799,31	-949,397	111,027	max(L6,L11,L22,L27)
	7	-3138,67	-722,743	-681,301	230,903	max(L7,L10,L23,L26)
	8	-3400,92	-894,071	-852,06	418,063	max(L8,L19,L24,L25)

	EnvSLU	M		V		
		min	max	min	max	
	Trasversale	1	-1172,79	1542,364	-376,313	
	2	-1390,67	1793,034	-397,686	159,435	max(T2,T15,T18,T31)
	3	-1765,78	2263,195	-591,672	185,82	max(T3,T14,T19,T30)
	4	-2474,28	3091,787	-1548,23	652,399	max(T4,T13,T20,T29)
	5	-3360,39	5209,43	-1707,56	6808,518	max(T5,T12,T21,T28)
	6	-2736,7	3635,426	-1158,19	-283,08	max(T6,T11,T22,T27)

	EnvSLE	M		
		min	max	
	Longitudinale	1	-1524,88	
	2	-1700,89	-757,095	max(L2,L15,L18,L31)
	3	-2166,07	-739,202	max(L3,L14,L19,L30)
	4	-2518,96	-575,62	max(L4,L13,L20,L29)
	5	-4520,61	-809,641	max(L5,L12,L21,L28)
	6	-2283,47	-495,694	max(L6,L11,L22,L27)
	7	-1906,82	-418,843	max(L7,L10,L23,L26)
	8	-2145,78	-488,171	max(L8,L19,L24,L25)

	EnvSLE	M		
		min	max	
	Trasversale	1	-742,155	
	2	-862,981	1112,103	max(T2,T11,T14,T23)
	3	-1076,07	1342,034	max(T3,T10,T15,T22)
	4	-1785,8	1502,838	max(T4,T9,T16,T21)
	5	-2175,41	2873,266	max(T5,T8,T17,T20)
	6	-1702,99	3028,545	max(T6,T7,T18,T19)

APPALTATORE: Consorzio Soci   		ITINERARIO NAPOLI – BARI					
PROGETTAZIONE: Mandataria Mandanti   		RADDOPPIO TRATTA APICE – ORSARA I LOTTO FUNZIONALE APICE – HIRPINIA					
PROGETTO ESECUTIVO RELAZIONE DI CALCOLO FONDAZIONI PILE P1, P2, P21, P22, P23 E P24		COMMESSA IF28	LOTTO 01	CODIFICA E ZZ CL	DOCUMENTO VI0403 002	REV. B	FOGLIO 84 di 161

Inviluppando SLU ed SLV, per le verifiche agli stati limite ultimi si ottiene:

Longitudinale	EnvSLV/SLU	M		V		
		min	max	min	max	
	1	-2722,85	1449,795	-348,226	154,76	
2	-3172,03	1859,523	-424,855	212,325	max(L2,L15,L18,L31)	
3	-4060,78	2432,463	-908,912	401,481	max(L3,L14,L19,L30)	
4	-4243,63	2479,863	-2366,15	4505,665	max(L4,L13,L20,L29)	
5	-7992,57	4656,566	-2696,06	3768,285	max(L5,L12,L21,L28)	
6	-4615,38	2290,941	-1194,28	715,948	max(L6,L11,L22,L27)	
7	-3701,29	1885,469	-855,266	682,461	max(L7,L10,L23,L26)	
8	-4072,46	2139,538	-1020,44	890,914	max(L8,L19,L24,L25)	

Trasversale	EnvSLV/SLU	M		V		
		min	max	min	max	
	1	-1172,79	1747,348	-510,844	244,252	
2	-1390,67	2036,17	-542,944	282,135	max(T2,T11,T14,T23)	
3	-1765,78	2554,948	-811,645	441,852	max(T3,T10,T15,T22)	
4	-2726,91	3419,555	-2101,85	1080,9	max(T4,T9,T16,T21)	
5	-3360,39	5839,505	-2931,27	7069,852	max(T5,T8,T17,T20)	
6	-2736,7	5180,383	-1560,74	534,271	max(T6,T7,T18,T19)	

APPALTATORE: Consorzio HirpiniaAV Soci salini impregilo ASTALDI	ITINERARIO NAPOLI – BARI RADDOPPIO TRATTA APICE – ORSARA I LOTTO FUNZIONALE APICE – HIRPINIA					
PROGETTAZIONE: Mandataria ROKSOJL Mandanti NETENGINEERING Alpina						
PROGETTO ESECUTIVO RELAZIONE DI CALCOLO FONDAZIONI PILE P1, P2, P21, P22, P23 E P24	COMMESSA IF28	LOTTO 01	CODIFICA E ZZ CL	DOCUMENTO VI0403 002	REV. B	FOGLIO 85 di 161

11.3.2 Verifiche a flessione e taglio

I criteri di verifica per gli stati limite ultimi e per gli stati limite di esercizio (fessurazione e limiti tensionali) sono stati esplicitati in precedenza.

Caratteristiche materiali e parametri di verifica sono sintetizzati di seguito:

materiali			
calcestruzzo		acciaio	
R_{ck}	35 [MPa]	f_{yk}	450 [MPa]
f_{ck}	29,1 [MPa]	γ_s	1,15
γ_c	1,5	f_{yd}	391,3 [MPa]
α_{cc}	0,85	E_s	210000 [MPa]
f_{cd}	16,5 [MPa]	ϵ_{uk}	75 [%]
ν	0,530		
ϵ_{c2}	2,0 [%]		
ϵ_{cu2}	3,5 [%]		
α_e	15,0		
k_t	0,4	valori limite	
k_1	0,8	0,45 f_{ck}	13,1 [MPa]
k_3	3,4	0,8 f_{yk}	360,0 [MPa]
k_4	0,425	$w_{k,lim}$	0,2 [mm]

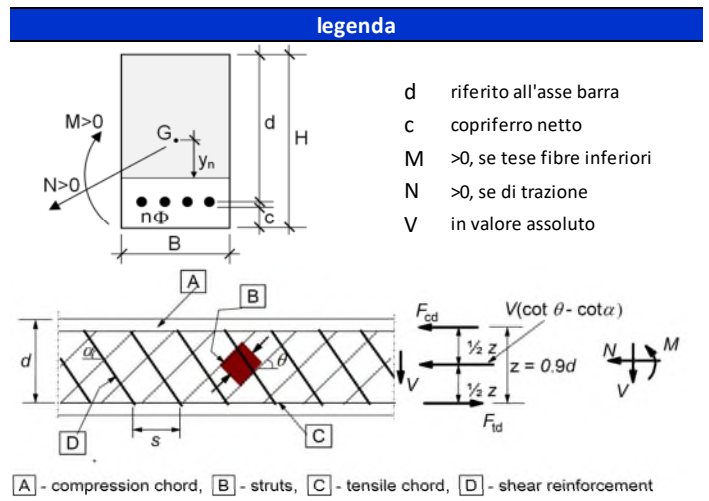

L'armatura base è composta da una maglia di $\phi 32$ con passo 15cm, la quale viene aggiunto un raffittimento nelle zone maggiormente sollecitate, in quale possono essere a passo 30cm. L'armatura in direzione trasversale è posta sopra la longitudinale motivo per cui nelle seguenti verifiche si ha un copriferro maggiore nelle armature trasversali. Si considera che gli spilli non siano legati alle barre più interne, motivo per cui non sono considerate nel calcolo del copriferro.

A favore di sicurezza nelle seguenti verifiche si considera solo lo strato più esterno di armatura compressa.

APPALTATORE: Consorzio Soci   	ITINERARIO NAPOLI – BARI RADDOPPIO TRATTA APICE – ORSARA I LOTTO FUNZIONALE APICE – HIRPINIA					
PROGETTAZIONE: Mandataria Mandanti   						
PROGETTO ESECUTIVO RELAZIONE DI CALCOLO FONDAZIONI PILE P1, P2, P21, P22, P23 E P24	COMMESSA IF28	LOTTO 01	CODIFICA E ZZ CL	DOCUMENTO VI0403 002	REV. B	FOGLIO 86 di 161

Sezione 1 longitudinale:

- *verifica armature inferiori:*

geometria				
sezione trasversale				
B	H	c	d	z
[cm]	[cm]	[cm]	[cm]	[cm]
100	250	5,0	243,4	219,1
armatura longitudinale				
nbarre	φ	d	Asi	
	[mm]	[cm]	[cm ²]	
6,66667	32	6,6	53,62	
6,66667	32	243,4	53,62	
armatura a taglio				
nbracci	φ	s	α	Asw
	[mm]	[cm]	[°]	[cm ²]
3,33333	16	60	90	6,70

- *verifica armature superiore:*

geometria				
sezione trasversale				
B	H	c	d	z
[cm]	[cm]	[cm]	[cm]	[cm]
100	250	5,0	243,4	219,1
armatura longitudinale				
nbarre	φ	d	Asi	
	[mm]	[cm]	[cm ²]	
6,66667	32	6,6	53,62	
6,66667	32	243,4	53,62	
armatura a taglio				
nbracci	φ	s	α	Asw
	[mm]	[cm]	[°]	[cm ²]
3,33333	16	60	90	6,70

sollecitazioni e risultati	
SLE	SLU
MEk 1525,00 [kNm]	MEd 2723,00 [kNm]
NEk 0 [kN]	NEd 0 [kN]
tensioni e fessure	
Mdec 0,0 [kNm]	
Mcr 2858,7 [kNm]	
yn -75,66 [cm]	
σ _{c,min} -2,1 [MPa]	
σ _{s,min} -27,3 [MPa]	
σ _{s,max} 124,1 [MPa]	
k ₂ 0,5	
ε _{sm} -ε _{cm} - [%o]	
Sr,max - [cm]	
Wk - [mm]	
presso-flessione	
MRd 5001,0 [kNm]	
FS 1,84	
taglio	
VRdc 670,1 [kN]	
non serve armatura a taglio	
VRds 1658,4 [kN]	
VRdmax 8280,2 [kN]	
θ 30,0 [°]	
sezione duttile	
ai 243,4 [cm]	

sollecitazioni e risultati	
SLE	SLU
MEk 0,00 [kNm]	MEd 1450,00 [kNm]
NEk 0 [kN]	NEd 0 [kN]
tensioni e fessure	
Mdec 0,0 [kNm]	
Mcr -2858,7 [kNm]	
yn 75,66 [cm]	
σ _{c,min} 0,0 [MPa]	
σ _{s,min} 0,0 [MPa]	
σ _{s,max} 0,0 [MPa]	
k ₂ 0,5	
ε _{sm} -ε _{cm} - [%o]	
Sr,max - [cm]	
Wk - [mm]	
presso-flessione	
MRd 5001,0 [kNm]	
FS 3,45	
taglio	
VRdc 670,1 [kN]	
non serve armatura a taglio	
VRds 1658,4 [kN]	
VRdmax 8280,2 [kN]	
θ 30,0 [°]	
sezione duttile	
ai 243,4 [cm]	

APPALTATORE: Consorzio HirpiniaAV Soci salini impregilo ASTALDI	ITINERARIO NAPOLI – BARI RADDOPPIO TRATTA APICE – ORSARA I LOTTO FUNZIONALE APICE – HIRPINIA					
PROGETTAZIONE: Mandataria SOJL Mandanti NETENGINEERING Alpina						
PROGETTO ESECUTIVO RELAZIONE DI CALCOLO FONDAZIONI PILE P1, P2, P21, P22, P23 E P24	COMMESSA IF28	LOTTO 01	CODIFICA E ZZ CL	DOCUMENTO VI0403 002	REV. B	FOGLIO 87 di 161

Sezione 2 longitudinale:

- *verifica armature inferiori:*

geometria				
sezione trasversale				
B	H	c	d	z
[cm]	[cm]	[cm]	[cm]	[cm]
100	250	5,0	243,4	219,1
armatura longitudinale				
nbarre	φ	d	Asi	
	[mm]	[cm]	[cm ²]	
6,66667	32	6,6	53,62	
6,66667	32	243,4	53,62	
armatura a taglio				
nbracci	φ	s	α	Asw
	[mm]	[cm]	[°]	[cm ²]
3,33333	16	60	90	6,70

- *verifica armature superiore:*

geometria				
sezione trasversale				
B	H	c	d	z
[cm]	[cm]	[cm]	[cm]	[cm]
100	250	5,0	243,4	219,1
armatura longitudinale				
nbarre	φ	d	Asi	
	[mm]	[cm]	[cm ²]	
6,66667	32	6,6	53,62	
6,66667	32	243,4	53,62	
armatura a taglio				
nbracci	φ	s	α	Asw
	[mm]	[cm]	[°]	[cm ²]
3,33333	16	60	90	6,70

sollecitazioni e risultati	
SLE	SLU
MEk 1701,00 [kNm]	MEd 3173,00 [kNm]
NEk 0 [kN]	NEd 0 [kN]
tensioni e fessure	
Mdec 0,0 [kNm]	
Mcr 2858,7 [kNm]	
yn -75,66 [cm]	
σ _{c,min} -2,3 [MPa]	
σ _{s,min} -30,5 [MPa]	
σ _{s,max} 138,5 [MPa]	
k ₂ 0,5	
ε _{sm} -ε _{cm} - [%]	
Sr,max - [cm]	
Wk - [mm]	
presso-flessione	
MRd 5001,0 [kNm]	
FS 1,58	
taglio	
VRdc 670,1 [kN]	
non serve armatura a taglio	
VRds 1658,4 [kN]	
VRdmax 8280,2 [kN]	
θ 30,0 [°]	
sezione duttile	
ai 243,4 [cm]	

sollecitazioni e risultati	
SLE	SLU
MEk 0,00 [kNm]	MEd 1860,00 [kNm]
NEk 0 [kN]	NEd 0 [kN]
tensioni e fessure	
Mdec 0,0 [kNm]	
Mcr -2858,7 [kNm]	
yn 75,66 [cm]	
σ _{c,min} 0,0 [MPa]	
σ _{s,min} 0,0 [MPa]	
σ _{s,max} 0,0 [MPa]	
k ₂ 0,5	
ε _{sm} -ε _{cm} - [%]	
Sr,max - [cm]	
Wk - [mm]	
presso-flessione	
MRd 5001,0 [kNm]	
FS 2,69	
taglio	
VRdc 670,1 [kN]	
non serve armatura a taglio	
VRds 1658,4 [kN]	
VRdmax 8280,2 [kN]	
θ 30,0 [°]	
sezione duttile	
ai 243,4 [cm]	

APPALTATORE: Consorzio Soci   	ITINERARIO NAPOLI – BARI RADDOPPIO TRATTA APICE – ORSARA I LOTTO FUNZIONALE APICE – HIRPINIA					
PROGETTAZIONE: Mandataria Mandanti   						
PROGETTO ESECUTIVO RELAZIONE DI CALCOLO FONDAZIONI PILE P1, P2, P21, P22, P23 E P24	COMMESSA IF28	LOTTO 01	CODIFICA E ZZ CL	DOCUMENTO VI0403 002	REV. B	FOGLIO 88 di 161

Sezione 3 longitudinale:

- *verifica armature inferiori:*

geometria				
sezione trasversale				
B	H	c	d	z
[cm]	[cm]	[cm]	[cm]	[cm]
100	250	5,0	243,4	219,1
armatura longitudinale				
nbarre	φ	d	Asi	
	[mm]	[cm]	[cm ²]	
6,66667	32	6,6	53,62	
6,66667	32	243,4	53,62	
armatura a taglio				
nbracci	φ	s	α	Asw
	[mm]	[cm]	[°]	[cm ²]
3,33333	16	60	90	6,70

- *verifica armature superiore:*

geometria				
sezione trasversale				
B	H	c	d	z
[cm]	[cm]	[cm]	[cm]	[cm]
100	250	5,0	243,4	219,1
armatura longitudinale				
nbarre	φ	d	Asi	
	[mm]	[cm]	[cm ²]	
6,66667	32	6,6	53,62	
6,66667	32	243,4	53,62	
armatura a taglio				
nbracci	φ	s	α	Asw
	[mm]	[cm]	[°]	[cm ²]
3,33333	16	60	90	6,70

sollecitazioni e risultati	
SLE	SLU
MEk 2166,00 [kNm]	MEd 4061,00 [kNm]
NEk 0 [kN]	NEd 0 [kN]
tensioni e fessure	
Mdec 0,0 [kNm]	
Mcr 2858,7 [kNm]	
yn -75,66 [cm]	
σ _{c,min} -3,0 [MPa]	
σ _{s,min} -38,8 [MPa]	
σ _{s,max} 176,3 [MPa]	
k ₂ 0,5	
ε _{sm} -ε _{cm} - [%]	
Sr,max - [cm]	
Wk - [mm]	
presso-flessione	
MRd 5001,0 [kNm]	
FS 1,23	
taglio	
VRdc 670,1 [kN]	
predisporre armatura a taglio	
VRds 1658,4 [kN]	
VRdmax 8280,2 [kN]	
θ 30,0 [°]	
sezione duttile	
ai 189,7 [cm]	

sollecitazioni e risultati	
SLE	SLU
MEk 0,00 [kNm]	MEd 2432,00 [kNm]
NEk 0 [kN]	NEd 0 [kN]
tensioni e fessure	
Mdec 0,0 [kNm]	
Mcr -2858,7 [kNm]	
yn 75,66 [cm]	
σ _{c,min} 0,0 [MPa]	
σ _{s,min} 0,0 [MPa]	
σ _{s,max} 0,0 [MPa]	
k ₂ 0,5	
ε _{sm} -ε _{cm} - [%]	
Sr,max - [cm]	
Wk - [mm]	
presso-flessione	
MRd 5001,0 [kNm]	
FS 2,06	
taglio	
VRdc 670,1 [kN]	
predisporre armatura a taglio	
VRds 1658,4 [kN]	
VRdmax 8280,2 [kN]	
θ 30,0 [°]	
sezione duttile	
ai 189,7 [cm]	

APPALTATORE: Consorzio Soci   	ITINERARIO NAPOLI – BARI RADDOPPIO TRATTA APICE – ORSARA I LOTTO FUNZIONALE APICE – HIRPINIA					
PROGETTAZIONE: Mandataria Mandanti   						
PROGETTO ESECUTIVO RELAZIONE DI CALCOLO FONDAZIONI PILE P1, P2, P21, P22, P23 E P24	COMMESSA IF28	LOTTO 01	CODIFICA E ZZ CL	DOCUMENTO VI0403 002	REV. B	FOGLIO 89 di 161

Sezione 4 longitudinale:

- *verifica armature inferiori:*

geometria				
sezione trasversale				
B	H	c	d	z
[cm]	[cm]	[cm]	[cm]	[cm]
100	250	5,0	243,4	219,1
armatura longitudinale				
nbarre	φ	d	Asi	
	[mm]	[cm]	[cm ²]	
6,66667	32	6,6	53,62	
6,66667	32	243,4	53,62	
armatura a taglio				
nbracci	φ	s	α	Asw
	[mm]	[cm]	[°]	[cm ²]
3,33333	16	15	90	6,70

- *verifica armature superiore:*

geometria				
sezione trasversale				
B	H	c	d	z
[cm]	[cm]	[cm]	[cm]	[cm]
100	250	5,0	243,4	219,1
armatura longitudinale				
nbarre	φ	d	Asi	
	[mm]	[cm]	[cm ²]	
6,66667	32	6,6	53,62	
6,66667	32	243,4	53,62	
armatura a taglio				
nbracci	φ	s	α	Asw
	[mm]	[cm]	[°]	[cm ²]
3,33333	16	15	90	6,70

sollecitazioni e risultati	
SLE	SLU
MEk 2519,00 [kNm]	MEd 4244,00 [kNm]
NEk 0 [kN]	NEd 0 [kN]
tensioni e fessure	
Mdec 0,0 [kNm]	
Mcr 2858,7 [kNm]	
yn -75,66 [cm]	
σ _{c,min} -3,5 [MPa]	
σ _{s,min} -45,2 [MPa]	
σ _{s,max} 205,1 [MPa]	
k ₂ 0,5	
ε _{sm} -ε _{cm} - [%o]	
Sr,max - [cm]	
Wk - [mm]	
presso-flessione	
MRd 5001,0 [kNm]	
FS 1,18	
taglio	
VRdc 670,1 [kN]	
predisporre armatura a taglio	
VRds 6633,7 [kN]	
VRdmax 8280,2 [kN]	
θ 30,0 [°]	
sezione duttile	
ai 189,7 [cm]	

sollecitazioni e risultati	
SLE	SLU
MEk 0,00 [kNm]	MEd 2480,00 [kNm]
NEk 0 [kN]	NEd 0 [kN]
VEk 4506,00 [kN]	VED 4506,00 [kN]
tensioni e fessure	
Mdec 0,0 [kNm]	
Mcr -2858,7 [kNm]	
yn 75,66 [cm]	
σ _{c,min} 0,0 [MPa]	
σ _{s,min} 0,0 [MPa]	
σ _{s,max} 0,0 [MPa]	
k ₂ 0,5	
ε _{sm} -ε _{cm} - [%o]	
Sr,max - [cm]	
Wk - [mm]	
presso-flessione	
MRd 5001,0 [kNm]	
FS 2,02	
taglio	
VRdc 670,1 [kN]	
predisporre armatura a taglio	
VRds 6633,7 [kN]	
VRdmax 8280,2 [kN]	
θ 30,0 [°]	
sezione duttile	
ai 189,7 [cm]	

APPALTATORE: Consorzio Soci   	ITINERARIO NAPOLI – BARI RADDOPPIO TRATTA APICE – ORSARA I LOTTO FUNZIONALE APICE – HIRPINIA					
PROGETTAZIONE: Mandataria Mandanti   						
PROGETTO ESECUTIVO RELAZIONE DI CALCOLO FONDAZIONI PILE P1, P2, P21, P22, P23 E P24	COMMESSA IF28	LOTTO 01	CODIFICA E ZZ CL	DOCUMENTO VI0403 002	REV. B	FOGLIO 90 di 161

Sezione 5 longitudinale:

- *verifica armature inferiori:*

geometria				
sezione trasversale				
B	H	c	d	z
[cm]	[cm]	[cm]	[cm]	[cm]
100	250	5,0	242,1	217,9
armatura longitudinale				
nbarre	φ	d	Asi	
	[mm]	[cm]	[cm ²]	
13,3333	32	6,6	107,23	
3,33333	32	237,0	26,81	
13,3333	32	243,4	107,23	
armatura a taglio				
nbracci	φ	s	α	Asw
	[mm]	[cm]	[°]	[cm ²]
3,33333	16	15	90	6,70

- *verifica armature superiore:*

geometria				
sezione trasversale				
B	H	c	d	z
[cm]	[cm]	[cm]	[cm]	[cm]
100	250	5,0	243,4	219,1
armatura longitudinale				
nbarre	φ	d	Asi	
	[mm]	[cm]	[cm ²]	
13,3333	32	6,6	107,23	
13,3333	32	243,4	107,23	
armatura a taglio				
nbracci	φ	s	α	Asw
	[mm]	[cm]	[°]	[cm ²]
3,33333	16	15	90	6,70

sollecitazioni e risultati	
SLE	SLU
MEk 4521,00 [kNm]	MEd 7993,00 [kNm]
NEk 0 [kN]	NEd 0 [kN]
tensioni e fessure	
Mdec 0,0 [kNm]	
Mcr 3384,4 [kNm]	
yn -55,09 [cm]	
σ _{c,min} -4,1 [MPa]	
σ _{s,min} -55,4 [MPa]	
σ _{s,max} 151,9 [MPa]	
k ₂ 0,5	
ε _{sm} -ε _{cm} 0,54 [‰]	
Sr,max 26,9 [cm]	
wk 0,146 [mm]	
presso-flessione	
MRd 12373,8 [kNm]	
FS 1,55	
taglio	
VRdc 667,2 [kN]	
predisporre armatura a taglio	
VRds 6598,8 [kN]	
VRdmax 8236,7 [kN]	
θ 30,0 [°]	
sezione duttile	
ai 188,7 [cm]	

sollecitazioni e risultati	
SLE	SLU
MEk 0,00 [kNm]	MEd 4657,00 [kNm]
NEk 0 [kN]	NEd 0 [kN]
VEd 3769,00 [kN]	
tensioni e fessure	
Mdec 0,0 [kNm]	
Mcr -3256,5 [kNm]	
yn 61,89 [cm]	
σ _{c,min} 0,0 [MPa]	
σ _{s,min} 0,0 [MPa]	
σ _{s,max} 0,0 [MPa]	
k ₂ 0,5	
ε _{sm} -ε _{cm} - [‰]	
Sr,max - [cm]	
wk - [mm]	
presso-flessione	
MRd 9966,3 [kNm]	
FS 2,14	
taglio	
VRdc 670,1 [kN]	
predisporre armatura a taglio	
VRds 6633,7 [kN]	
VRdmax 8280,2 [kN]	
θ 30,0 [°]	
sezione duttile	
ai 189,7 [cm]	

APPALTATORE: Consorzio Soci   	ITINERARIO NAPOLI – BARI RADDOPPIO TRATTA APICE – ORSARA I LOTTO FUNZIONALE APICE – HIRPINIA					
PROGETTAZIONE: Mandataria Mandanti   						
PROGETTO ESECUTIVO RELAZIONE DI CALCOLO FONDAZIONI PILE P1, P2, P21, P22, P23 E P24	COMMESSA IF28	LOTTO 01	CODIFICA E ZZ CL	DOCUMENTO VI0403 002	REV. B	FOGLIO 91 di 161

Sezione 6 longitudinale:

- *verifica armature inferiori:*



geometria				
sezione trasversale				
B	H	c	d	z
[cm]	[cm]	[cm]	[cm]	[cm]
100	250	5,0	243,4	219,1
armatura longitudinale				
nbarre	φ	d	Asi	
	[mm]	[cm]	[cm ²]	
6,66667	32	6,6	53,62	
10	32	243,4	80,42	
armatura a taglio				
nbracci	φ	s	α	Asw
	[mm]	[cm]	[°]	[cm ²]
3,33333	16	60	90	6,70

- *verifica armature superiore:*

geometria				
sezione trasversale				
B	H	c	d	z
[cm]	[cm]	[cm]	[cm]	[cm]
100	250	5,0	243,4	219,1
armatura longitudinale				
nbarre	φ	d	Asi	
	[mm]	[cm]	[cm ²]	
10	32	6,6	80,42	
6,66667	32	243,4	53,62	
armatura a taglio				
nbracci	φ	s	α	Asw
	[mm]	[cm]	[°]	[cm ²]
3,33333	16	60	90	6,70

sollecitazioni e risultati	
SLE	SLU
MEk 2284,00 [kNm]	MEd 4616,00 [kNm]
NEk 0 [kN]	NEd 0 [kN]
tensioni e fessure	
Mdec 0,0 [kNm]	
Mcr 2996,4 [kNm]	
yn -65,21 [cm]	
σ _{c,min} -2,7 [MPa]	
σ _{s,min} -36,4 [MPa]	
σ _{s,max} 125,6 [MPa]	
k ₂ 0,5	
ε _{sm} -ε _{cm} - [%]	
Sr,max - [cm]	
Wk - [mm]	
presso-flessione	
MRd 7479,7 [kNm]	
FS 1,62	
taglio	
VRdc 670,1 [kN]	
predisporre armatura a taglio	
VRds 1658,4 [kN]	
VRdmax 8280,2 [kN]	
θ 30,0 [°]	
sezione duttile	
ai 189,7 [cm]	

sollecitazioni e risultati	
SLE	SLU
MEk 0,00 [kNm]	MEd 2291,00 [kNm]
NEk 0 [kN]	NEd 0 [kN]
tensioni e fessure	
Mdec 0,0 [kNm]	
Mcr -2996,4 [kNm]	
yn 65,21 [cm]	
σ _{c,min} 0,0 [MPa]	
σ _{s,min} 0,0 [MPa]	
σ _{s,max} 0,0 [MPa]	
k ₂ 0,5	
ε _{sm} -ε _{cm} - [%]	
Sr,max - [cm]	
Wk - [mm]	
presso-flessione	
MRd 5001,7 [kNm]	
FS 2,18	
taglio	
VRdc 670,1 [kN]	
predisporre armatura a taglio	
VRds 1658,4 [kN]	
VRdmax 8280,2 [kN]	
θ 30,0 [°]	
sezione duttile	
ai 189,7 [cm]	

APPALTATORE: Consorzio Soci   	ITINERARIO NAPOLI – BARI RADDOPPIO TRATTA APICE – ORSARA I LOTTO FUNZIONALE APICE – HIRPINIA					
PROGETTAZIONE: Mandataria Mandanti   						
PROGETTO ESECUTIVO RELAZIONE DI CALCOLO FONDAZIONI PILE P1, P2, P21, P22, P23 E P24	COMMESSA IF28	LOTTO 01	CODIFICA E ZZ CL	DOCUMENTO VI0403 002	REV. B	FOGLIO 92 di 161

Sezione 7 longitudinale:

- *verifica armature inferiori:*

geometria				
sezione trasversale				
B	H	c	d	z
[cm]	[cm]	[cm]	[cm]	[cm]
100	250	5,0	243,4	219,1
armatura longitudinale				
nbarre	φ	d	Asi	
	[mm]	[cm]	[cm ²]	
6,66667	32	6,6	53,62	
6,66667	32	243,4	53,62	
armatura a taglio				
nbracci	φ	s	α	Asw
	[mm]	[cm]	[°]	[cm ²]
3,33333	16	60	90	6,70

- *verifica armature superiore:*

geometria				
sezione trasversale				
B	H	c	d	z
[cm]	[cm]	[cm]	[cm]	[cm]
100	250	5,0	243,4	219,1
armatura longitudinale				
nbarre	φ	d	Asi	
	[mm]	[cm]	[cm ²]	
6,66667	32	6,6	53,62	
6,66667	32	243,4	53,62	
armatura a taglio				
nbracci	φ	s	α	Asw
	[mm]	[cm]	[°]	[cm ²]
3,33333	16	60	90	6,70

sollecitazioni e risultati	
SLE	SLU
MEk 1907,00 [kNm]	MEd 3702,00 [kNm]
NEk 0 [kN]	NEd 0 [kN]
tensioni e fessure	
Mdec 0,0 [kNm]	
Mcr 2858,7 [kNm]	
yn -75,66 [cm]	
σ _{c,min} -2,6 [MPa]	
σ _{s,min} -34,2 [MPa]	
σ _{s,max} 155,2 [MPa]	
k ₂ 0,5	
ε _{sm} -ε _{cm} - [%o]	
Sr,max - [cm]	
Wk - [mm]	
presso-flessione	
MRd 5001,0 [kNm]	
FS 1,35	
taglio	
VRdc 670,1 [kN]	
predisporre armatura a taglio	
VRds 1658,4 [kN]	
VRdmax 8280,2 [kN]	
θ 30,0 [°]	
sezione duttile	
ai 189,7 [cm]	

sollecitazioni e risultati	
SLE	SLU
MEk 0,00 [kNm]	MEd 1885,00 [kNm]
NEk 0 [kN]	NEd 0 [kN]
tensioni e fessure	
Mdec 0,0 [kNm]	
Mcr -2858,7 [kNm]	
yn 75,66 [cm]	
σ _{c,min} 0,0 [MPa]	
σ _{s,min} 0,0 [MPa]	
σ _{s,max} 0,0 [MPa]	
k ₂ 0,5	
ε _{sm} -ε _{cm} - [%o]	
Sr,max - [cm]	
Wk - [mm]	
presso-flessione	
MRd 5001,0 [kNm]	
FS 2,65	
taglio	
VRdc 670,1 [kN]	
predisporre armatura a taglio	
VRds 1658,4 [kN]	
VRdmax 8280,2 [kN]	
θ 30,0 [°]	
sezione duttile	
ai 189,7 [cm]	

APPALTATORE: Consorzio Soci   	ITINERARIO NAPOLI – BARI RADDOPPIO TRATTA APICE – ORSARA I LOTTO FUNZIONALE APICE – HIRPINIA					
PROGETTAZIONE: Mandataria Mandanti   						
PROGETTO ESECUTIVO RELAZIONE DI CALCOLO FONDAZIONI PILE P1, P2, P21, P22, P23 E P24	COMMESSA IF28	LOTTO 01	CODIFICA E ZZ CL	DOCUMENTO VI0403 002	REV. B	FOGLIO 93 di 161

Sezione 8 longitudinale:

- *verifica armature inferiori:*

geometria				
sezione trasversale				
B	H	c	d	z
[cm]	[cm]	[cm]	[cm]	[cm]
100	250	5,0	243,4	219,1
armatura longitudinale				
nbarre	φ	d	Asi	
	[mm]	[cm]	[cm ²]	
6,66667	32	6,6	53,62	
6,66667	32	243,4	53,62	
armatura a taglio				
nbracci	φ	s	α	Asw
	[mm]	[cm]	[°]	[cm ²]
3,33333	16	60	90	6,70

- *verifica armature superiore:*

geometria				
sezione trasversale				
B	H	c	d	z
[cm]	[cm]	[cm]	[cm]	[cm]
100	250	5,0	243,4	219,1
armatura longitudinale				
nbarre	φ	d	Asi	
	[mm]	[cm]	[cm ²]	
6,66667	32	6,6	53,62	
6,66667	32	243,4	53,62	
armatura a taglio				
nbracci	φ	s	α	Asw
	[mm]	[cm]	[°]	[cm ²]
3,33333	16	60	90	6,70

sollecitazioni e risultati	
SLE	SLU
MEk 2145,00 [kNm]	MEd 4073,00 [kNm]
NEk 0 [kN]	NEd 0 [kN]
tensioni e fessure	
Mdec 0,0 [kNm]	
Mcr 2858,7 [kNm]	
yn -75,66 [cm]	
σ _{c,min} -3,0 [MPa]	
σ _{s,min} -38,5 [MPa]	
σ _{s,max} 174,6 [MPa]	
k ₂ 0,5	
ε _{sm} -ε _{cm} - [%]	
Sr,max - [cm]	
Wk - [mm]	
presso-flessione	
MRd 5001,0 [kNm]	
FS 1,23	
taglio	
VRdc 670,1 [kN]	
predisporre armatura a taglio	
VRds 1658,4 [kN]	
VRdmax 8280,2 [kN]	
θ 30,0 [°]	
sezione duttile	
ai 189,7 [cm]	

sollecitazioni e risultati	
SLE	SLU
MEk 0,00 [kNm]	MEd 2140,00 [kNm]
NEk 0 [kN]	NEd 0 [kN]
VEk 1021,00 [kN]	VED 1021,00 [kN]
tensioni e fessure	
Mdec 0,0 [kNm]	
Mcr -2858,7 [kNm]	
yn 75,66 [cm]	
σ _{c,min} 0,0 [MPa]	
σ _{s,min} 0,0 [MPa]	
σ _{s,max} 0,0 [MPa]	
k ₂ 0,5	
ε _{sm} -ε _{cm} - [%]	
Sr,max - [cm]	
Wk - [mm]	
presso-flessione	
MRd 5001,0 [kNm]	
FS 2,34	
taglio	
VRdc 670,1 [kN]	
predisporre armatura a taglio	
VRds 1658,4 [kN]	
VRdmax 8280,2 [kN]	
θ 30,0 [°]	
sezione duttile	
ai 189,7 [cm]	

APPALTATORE: Consorzio Soci   	ITINERARIO NAPOLI – BARI RADDOPPIO TRATTA APICE – ORSARA I LOTTO FUNZIONALE APICE – HIRPINIA					
PROGETTAZIONE: Mandataria Mandanti   						
PROGETTO ESECUTIVO RELAZIONE DI CALCOLO FONDAZIONI PILE P1, P2, P21, P22, P23 E P24	COMMESSA IF28	LOTTO 01	CODIFICA E ZZ CL	DOCUMENTO VI0403 002	REV. B	FOGLIO 94 di 161

Sezione 1 trasversale:

- *verifica armature inferiori:*

geometria				
sezione trasversale				
B	H	c	d	z
[cm]	[cm]	[cm]	[cm]	[cm]
100	250	8,2	240,2	216,2
armatura longitudinale				
nbarre	φ	d	Asl	
	[mm]	[cm]	[cm ²]	
6,66667	32	9,8	53,62	
6,66667	32	240,2	53,62	
armatura a taglio				
nbracci	φ	s	α	Asw
	[mm]	[cm]	[°]	[cm ²]
3,33333	16	60	90	6,70

- *verifica armature superiore:*

geometria				
sezione trasversale				
B	H	c	d	z
[cm]	[cm]	[cm]	[cm]	[cm]
100	250	8,2	240,2	216,2
armatura longitudinale				
nbarre	φ	d	Asl	
	[mm]	[cm]	[cm ²]	
6,66667	32	9,8	53,62	
6,66667	32	240,2	53,62	
armatura a taglio				
nbracci	φ	s	α	Asw
	[mm]	[cm]	[°]	[cm ²]
3,33333	16	60	90	6,70

sollecitazioni e risultati	
SLE	SLU
MEk 743,00 [kNm]	MEd 1173,00 [kNm]
NEk 0 [kN]	NEd 0 [kN]
tensioni e fessure	
Mdec 0,0 [kNm]	
Mcr 2837,5 [kNm]	
yn -75,66 [cm]	
σ _{c,min} -1,1 [MPa]	
σ _{s,min} -12,8 [MPa]	
σ _{s,max} 61,6 [MPa]	
k ₂ 0,5	
ε _{sm} -ε _{cm} - [%o]	
Sr,max - [cm]	
Wk - [mm]	
presso-flessione	
MRd 4910,2 [kNm]	
FS 4,19	
taglio	
VRdc 662,8 [kN]	
non serve armatura a taglio	
VRds 1636,6 [kN]	
VRdmax 8171,4 [kN]	
θ 30,0 [°]	
sezione duttile	
ai 240,2 [cm]	

sollecitazioni e risultati	
SLE	SLU
MEk 952,00 [kNm]	MEd 1748,00 [kNm]
NEk 0 [kN]	NEd 0 [kN]
tensioni e fessure	
Mdec 0,0 [kNm]	
Mcr 2837,5 [kNm]	
yn -75,66 [cm]	
σ _{c,min} -1,4 [MPa]	
σ _{s,min} -16,3 [MPa]	
σ _{s,max} 78,9 [MPa]	
k ₂ 0,5	
ε _{sm} -ε _{cm} - [%o]	
Sr,max - [cm]	
Wk - [mm]	
presso-flessione	
MRd 4910,2 [kNm]	
FS 2,81	
taglio	
VRdc 662,8 [kN]	
non serve armatura a taglio	
VRds 1636,6 [kN]	
VRdmax 8171,4 [kN]	
θ 30,0 [°]	
sezione duttile	
ai 240,2 [cm]	

APPALTATORE: Consorzio HirpiniaAV Soci salini impregio ASTALDI	ITINERARIO NAPOLI – BARI RADDOPPIO TRATTA APICE – ORSARA I LOTTO FUNZIONALE APICE – HIRPINIA					
PROGETTAZIONE: Mandataria SOJL Mandanti NETENGINEERING Alpina						
PROGETTO ESECUTIVO RELAZIONE DI CALCOLO FONDAZIONI PILE P1, P2, P21, P22, P23 E P24	COMMESSA IF28	LOTTO 01	CODIFICA E ZZ CL	DOCUMENTO VI0403 002	REV. B	FOGLIO 95 di 161

Sezione 2 trasversale:

- *verifica armature inferiori:*

geometria				
sezione trasversale				
B	H	c	d	z
[cm]	[cm]	[cm]	[cm]	[cm]
100	250	8,2	240,2	216,2
armatura longitudinale				
nbarre	φ	d	Asl	
	[mm]	[cm]	[cm ²]	
6,66667	32	9,8	53,62	
6,66667	32	240,2	53,62	
armatura a taglio				
nbracci	φ	s	α	Asw
	[mm]	[cm]	[°]	[cm ²]
3,33333	16	60	90	6,70

- *verifica armature superiore:*

geometria				
sezione trasversale				
B	H	c	d	z
[cm]	[cm]	[cm]	[cm]	[cm]
100	250	8,2	240,2	216,2
armatura longitudinale				
nbarre	φ	d	Asl	
	[mm]	[cm]	[cm ²]	
6,66667	32	9,8	53,62	
6,66667	32	240,2	53,62	
armatura a taglio				
nbracci	φ	s	α	Asw
	[mm]	[cm]	[°]	[cm ²]
3,33333	16	60	90	6,70

sollecitazioni e risultati	
SLE	SLU
MEk 863,00 [kNm]	MEd 1391,00 [kNm]
NEk 0 [kN]	NEd 0 [kN]
tensioni e fessure	
Mdec 0,0 [kNm]	
Mcr 2837,5 [kNm]	
yn -75,66 [cm]	
σ _{c,min} -1,2 [MPa]	
σ _{s,min} -14,8 [MPa]	
σ _{s,max} 71,5 [MPa]	
k ₂ 0,5	
ε _{sm} -ε _{cm} - [%]	
Sr,max - [cm]	
Wk - [mm]	
presso-flessione	
MRd 4910,2 [kNm]	
FS 3,53	
taglio	
VRdc 662,8 [kN]	
non serve armatura a taglio	
VRds 1636,6 [kN]	
VRdmax 8171,4 [kN]	
θ 30,0 [°]	
sezione duttile	
ai 240,2 [cm]	

sollecitazioni e risultati	
SLE	SLU
MEk 1112,00 [kNm]	MEd 2036,00 [kNm]
NEk 0 [kN]	NEd 0 [kN]
tensioni e fessure	
Mdec 0,0 [kNm]	
Mcr 2837,5 [kNm]	
yn -75,66 [cm]	
σ _{c,min} -1,6 [MPa]	
σ _{s,min} -19,1 [MPa]	
σ _{s,max} 92,1 [MPa]	
k ₂ 0,5	
ε _{sm} -ε _{cm} - [%]	
Sr,max - [cm]	
Wk - [mm]	
presso-flessione	
MRd 4910,2 [kNm]	
FS 2,41	
taglio	
VRdc 662,8 [kN]	
non serve armatura a taglio	
VRds 1636,6 [kN]	
VRdmax 8171,4 [kN]	
θ 30,0 [°]	
sezione duttile	
ai 240,2 [cm]	

APPALTATORE: Consorzio HirpiniaAV Soci salini impregio ASTALDI	ITINERARIO NAPOLI – BARI RADDOPPIO TRATTA APICE – ORSARA I LOTTO FUNZIONALE APICE – HIRPINIA					
PROGETTAZIONE: Mandataria SOJL Mandanti NETENGINEERING Alpina						
PROGETTO ESECUTIVO RELAZIONE DI CALCOLO FONDAZIONI PILE P1, P2, P21, P22, P23 E P24	COMMESSA IF28	LOTTO 01	CODIFICA E ZZ CL	DOCUMENTO VI0403 002	REV. B	FOGLIO 96 di 161

Sezione 3 trasversale:

- *verifica armature inferiori:*

geometria				
sezione trasversale				
B	H	c	d	z
[cm]	[cm]	[cm]	[cm]	[cm]
100	250	8,2	240,2	216,2
armatura longitudinale				
nbarre	φ	d	Asl	
	[mm]	[cm]	[cm ²]	
6,66667	32	9,8	53,62	
6,66667	32	240,2	53,62	
armatura a taglio				
nbracci	φ	s	α	Asw
	[mm]	[cm]	[°]	[cm ²]
3,33333	16	60	90	6,70

- *verifica armature superiore:*

geometria				
sezione trasversale				
B	H	c	d	z
[cm]	[cm]	[cm]	[cm]	[cm]
100	250	8,2	240,2	216,2
armatura longitudinale				
nbarre	φ	d	Asl	
	[mm]	[cm]	[cm ²]	
6,66667	32	9,8	53,62	
6,66667	32	240,2	53,62	
armatura a taglio				
nbracci	φ	s	α	Asw
	[mm]	[cm]	[°]	[cm ²]
3,33333	16	60	90	6,70

sollecitazioni e risultati	
SLE	SLU
MEk 1077,00 [kNm]	MEd 1766,00 [kNm]
NEk 0 [kN]	NEd 0 [kN]
tensioni e fessure	
Mdec 0,0 [kNm]	
Mcr 2837,5 [kNm]	
yn -75,66 [cm]	
σ _{c,min} -1,5 [MPa]	
σ _{s,min} -18,5 [MPa]	
σ _{s,max} 89,2 [MPa]	
k ₂ 0,5	
ε _{sm} -ε _{cm} - [%o]	
Sr,max - [cm]	
Wk - [mm]	
presso-flessione	
MRd 4910,2 [kNm]	
FS 2,78	
taglio	
VRdc 662,8 [kN]	
predisporre armatura a taglio	
VRds 1636,6 [kN]	
VRdmax 8171,4 [kN]	
θ 30,0 [°]	
sezione duttile	
ai 187,2 [cm]	

sollecitazioni e risultati	
SLE	SLU
MEk 1343,00 [kNm]	MEd 2555,00 [kNm]
NEk 0 [kN]	NEd 0 [kN]
tensioni e fessure	
Mdec 0,0 [kNm]	
Mcr 2837,5 [kNm]	
yn -75,66 [cm]	
σ _{c,min} -1,9 [MPa]	
σ _{s,min} -23,0 [MPa]	
σ _{s,max} 111,3 [MPa]	
k ₂ 0,5	
ε _{sm} -ε _{cm} - [%o]	
Sr,max - [cm]	
Wk - [mm]	
presso-flessione	
MRd 4910,2 [kNm]	
FS 1,92	
taglio	
VRdc 662,8 [kN]	
predisporre armatura a taglio	
VRds 1636,6 [kN]	
VRdmax 8171,4 [kN]	
θ 30,0 [°]	
sezione duttile	
ai 187,2 [cm]	

APPALTATORE: Consorzio Soci   	ITINERARIO NAPOLI – BARI RADDOPPIO TRATTA APICE – ORSARA I LOTTO FUNZIONALE APICE – HIRPINIA					
PROGETTAZIONE: Mandataria Mandanti   						
PROGETTO ESECUTIVO RELAZIONE DI CALCOLO FONDAZIONI PILE P1, P2, P21, P22, P23 E P24	COMMESSA IF28	LOTTO 01	CODIFICA E ZZ CL	DOCUMENTO VI0403 002	REV. B	FOGLIO 97 di 161

Sezione 4 trasversale:

- *verifica armature inferiori:*

geometria				
sezione trasversale				
B	H	c	d	z
[cm]	[cm]	[cm]	[cm]	[cm]
100	250	8,2	240,2	216,2
armatura longitudinale				
nbarre	φ	d	Asi	
	[mm]	[cm]	[cm ²]	
6,66667	32	9,8	53,62	
6,66667	32	240,2	53,62	
armatura a taglio				
nbracci	φ	s	α	Asw
	[mm]	[cm]	[°]	[cm ²]
3,33333	16	30	90	6,70

- *verifica armature superiore:*

geometria				
sezione trasversale				
B	H	c	d	z
[cm]	[cm]	[cm]	[cm]	[cm]
100	250	8,2	240,2	216,2
armatura longitudinale				
nbarre	φ	d	Asi	
	[mm]	[cm]	[cm ²]	
6,66667	32	9,8	53,62	
6,66667	32	240,2	53,62	
armatura a taglio				
nbracci	φ	s	α	Asw
	[mm]	[cm]	[°]	[cm ²]
3,33333	16	30	90	6,70

sollecitazioni e risultati	
SLE	SLU
MEk 1786,00 [kNm]	MEd 2727,00 [kNm]
NEk 0 [kN]	NEd 0 [kN]
tensioni e fessure	
Mdec 0,0 [kNm]	
Mcr 2837,5 [kNm]	
yn -75,66 [cm]	
σ _{c,min} -2,5 [MPa]	
σ _{s,min} -30,6 [MPa]	
σ _{s,max} 148,0 [MPa]	
k ₂ 0,5	
ε _{sm} -ε _{cm} - [%o]	
Sr,max - [cm]	
Wk - [mm]	
presso-flessione	
MRd 4910,2 [kNm]	
FS 1,80	
taglio	
VRdc 662,8 [kN]	
predisporre armatura a taglio	
VRds 3273,2 [kN]	
VRdmax 8171,4 [kN]	
θ 30,0 [°]	
sezione duttile	
ai 187,2 [cm]	

sollecitazioni e risultati	
SLE	SLU
MEk 1502,00 [kNm]	MEd 3420,00 [kNm]
NEk 0 [kN]	NEd 0 [kN]
tensioni e fessure	
Mdec 0,0 [kNm]	
Mcr 2837,5 [kNm]	
yn -75,66 [cm]	
σ _{c,min} -2,1 [MPa]	
σ _{s,min} -25,8 [MPa]	
σ _{s,max} 124,4 [MPa]	
k ₂ 0,5	
ε _{sm} -ε _{cm} - [%o]	
Sr,max - [cm]	
Wk - [mm]	
presso-flessione	
MRd 4910,2 [kNm]	
FS 1,44	
taglio	
VRdc 662,8 [kN]	
predisporre armatura a taglio	
VRds 3273,2 [kN]	
VRdmax 8171,4 [kN]	
θ 30,0 [°]	
sezione duttile	
ai 187,2 [cm]	

APPALTATORE: Consorzio Soci   	ITINERARIO NAPOLI – BARI RADDOPPIO TRATTA APICE – ORSARA I LOTTO FUNZIONALE APICE – HIRPINIA					
PROGETTAZIONE: Mandataria Mandanti   						
PROGETTO ESECUTIVO RELAZIONE DI CALCOLO FONDAZIONI PILE P1, P2, P21, P22, P23 E P24	COMMESSA IF28	LOTTO 01	CODIFICA E ZZ CL	DOCUMENTO VI0403 002	REV. B	FOGLIO 98 di 161

Sezione 5 trasversale:

- *verifica armature inferiori:*

geometria				
sezione trasversale				
B	H	c	d	z
[cm]	[cm]	[cm]	[cm]	[cm]
100	250	8,2	240,2	216,2
armatura longitudinale				
nbarre	φ	d	Asi	
	[mm]	[cm]	[cm ²]	
10	32	9,8	80,42	
10	32	240,2	80,42	
armatura a taglio				
nbracci	φ	s	α	Asw
	[mm]	[cm]	[°]	[cm ²]
3,33333	16	15	90	6,70

- *verifica armature superiore:*

geometria				
sezione trasversale				
B	H	c	d	z
[cm]	[cm]	[cm]	[cm]	[cm]
100	250	8,2	240,2	216,2
armatura longitudinale				
nbarre	φ	d	Asi	
	[mm]	[cm]	[cm ²]	
10	32	9,8	80,42	
10	32	240,2	80,42	
armatura a taglio				
nbracci	φ	s	α	Asw
	[mm]	[cm]	[°]	[cm ²]
3,33333	16	15	90	6,70

sollecitazioni e risultati	
SLE	SLU
MEk 2175,00 [kNm]	MEd 3360,00 [kNm]
NEk 0 [kN]	NEd 0 [kN]
tensioni e fessure	
Mdec 0,0 [kNm]	
Mcr 3025,8 [kNm]	
yn -67,80 [cm]	
σ _{c,min} -2,5 [MPa]	
σ _{s,min} -31,3 [MPa]	
σ _{s,max} 121,0 [MPa]	
k ₂ 0,5	
ε _{sm} -ε _{cm} - [%]	
Sr,max - [cm]	
Wk - [mm]	
presso-flessione	
MRd 7323,8 [kNm]	
FS 2,18	
taglio	
VRdc 662,8 [kN]	
predisporre armatura a taglio	
VRds 8105,4 [kN]	
VRdmax 7228,0 [kN]	
θ 25,0 [°]	
sezione duttile	
ai 231,8 [cm]	

sollecitazioni e risultati	
SLE	SLU
MEk 2874,00 [kNm]	MEd 5840,00 [kNm]
NEk 0 [kN]	NEd 0 [kN]
tensioni e fessure	
Mdec 0,0 [kNm]	
Mcr 3025,8 [kNm]	
yn -67,80 [cm]	
σ _{c,min} -3,3 [MPa]	
σ _{s,min} -41,4 [MPa]	
σ _{s,max} 159,9 [MPa]	
k ₂ 0,5	
ε _{sm} -ε _{cm} - [%]	
Sr,max - [cm]	
Wk - [mm]	
presso-flessione	
MRd 7323,8 [kNm]	
FS 1,25	
taglio	
VRdc 662,8 [kN]	
predisporre armatura a taglio	
VRds 8105,4 [kN]	
VRdmax 7228,0 [kN]	
θ 25,0 [°]	
sezione duttile	
ai 231,8 [cm]	

APPALTATORE: Consorzio Soci   	ITINERARIO NAPOLI – BARI RADDOPPIO TRATTA APICE – ORSARA I LOTTO FUNZIONALE APICE – HIRPINIA					
PROGETTAZIONE: Mandataria Mandanti   						
PROGETTO ESECUTIVO RELAZIONE DI CALCOLO FONDAZIONI PILE P1, P2, P21, P22, P23 E P24	COMMESSA IF28	LOTTO 01	CODIFICA E ZZ CL	DOCUMENTO VI0403 002	REV. B	FOGLIO 99 di 161

Sezione 6 trasversale:

- *verifica armature inferiori:*

geometria				
sezione trasversale				
B	H	c	d	z
[cm]	[cm]	[cm]	[cm]	[cm]
100	250	8,2	240,2	216,2
armatura longitudinale				
nbarre	φ	d	Asl	
	[mm]	[cm]	[cm ²]	
13,3333	32	9,8	107,23	
13,3333	32	240,2	107,23	
armatura a taglio				
nbracci	φ	s	α	Asw
	[mm]	[cm]	[°]	[cm ²]
3,33333	16	60	90	6,70

- *verifica armature superiore:*

geometria				
sezione trasversale				
B	H	c	d	z
[cm]	[cm]	[cm]	[cm]	[cm]
100	250	8,2	240,2	216,2
armatura longitudinale				
nbarre	φ	d	Asl	
	[mm]	[cm]	[cm ²]	
13,3333	32	9,8	107,23	
13,3333	32	240,2	107,23	
armatura a taglio				
nbracci	φ	s	α	Asw
	[mm]	[cm]	[°]	[cm ²]
3,33333	16	60	90	6,70

sollecitazioni e risultati	
SLE	SLU
MEk 1703,00 [kNm]	MEd 2737,00 [kNm]
NEk 0 [kN]	NEd 0 [kN]
tensioni e fessure	
Mdec 0,0 [kNm]	
Mcr 3214,0 [kNm]	
yn -61,89 [cm]	
σ _{c,min} -1,7 [MPa]	
σ _{s,min} -21,5 [MPa]	
σ _{s,max} 71,4 [MPa]	
k ₂ 0,5	
ε _{sm} -ε _{cm} - [%]	
Sr,max - [cm]	
Wk - [mm]	
presso-flessione	
MRd 9737,3 [kNm]	
FS 3,56	
taglio	
VRdc 662,8 [kN]	
predisporre armatura a taglio	
VRds 2026,4 [kN]	
VRdmax 7228,0 [kN]	
θ 25,0 [°]	
sezione duttile	
ai 231,8 [cm]	

sollecitazioni e risultati	
SLE	SLU
MEk 3029,00 [kNm]	MEd 5181,00 [kNm]
NEk 0 [kN]	NEd 0 [kN]
tensioni e fessure	
Mdec 0,0 [kNm]	
Mcr 3214,0 [kNm]	
yn -61,89 [cm]	
σ _{c,min} -3,0 [MPa]	
σ _{s,min} -38,2 [MPa]	
σ _{s,max} 126,9 [MPa]	
k ₂ 0,5	
ε _{sm} -ε _{cm} - [%]	
Sr,max - [cm]	
Wk - [mm]	
presso-flessione	
MRd 9737,3 [kNm]	
FS 1,88	
taglio	
VRdc 662,8 [kN]	
predisporre armatura a taglio	
VRds 2026,4 [kN]	
VRdmax 7228,0 [kN]	
θ 25,0 [°]	
sezione duttile	
ai 231,8 [cm]	

APPALTATORE: Consorzio  Soci  	ITINERARIO NAPOLI – BARI RADDOPPIO TRATTA APICE – ORSARA I LOTTO FUNZIONALE APICE – HIRPINIA					
PROGETTAZIONE: Mandataria  Mandanti  						
PROGETTO ESECUTIVO RELAZIONE DI CALCOLO FONDAZIONI PILE P1, P2, P21, P22, P23 E P24	COMMESSA IF28	LOTTO 01	CODIFICA E ZZ CL	DOCUMENTO VI0403 002	REV. B	FOGLIO 100 di 161

11.4 VERIFICA PUNZONAMENTO

La verifica a punzonamento viene eseguita in prima istanza trascurando la presenza di armatura e considerando l'azione assiale massima di compressione agente sui pali e ipotizzando di questa sia riferita ad un palo di bordo.

$$N_{Ed} \leq F_{Rd} = 0,5 \times u \times H \times f_{ctd}$$

Dove:

- u, perimetro del contorno;
- H, spessore del plinto;
- f_{ctd} , resistenza a trazione di progetto del calcestruzzo.

N_{Ed}	6652,0	kN
D_{palo}	1,5	m
$L_2 (D+3xD/2)$	3,8	m
$L_3 (D+3xD/2)$	3,8	m
f_{ck}	35,0	MPa
f_{ctd}	1,5	MPa
u	7,5	m
H_{plinto}	2,5	m
$F_{Rd, Punzonamento}$	14043,6	kN
$F_{Rd, Punzonamento}/N_{Ed}$	2,1	[-]
Verificato		

Tale verifica risulta soddisfatta nelle condizioni esplicitate, quindi viene eseguita la verifica considerando la presenza di armatura e l'effettiva posizione del palo.

11.5 STIMA INCIDENZE DI ARMATURA

Per la stima delle incidenze di armatura del plinto di fondazione si rimanda al Viadotto VI01 che presenta configurazione di carichi e geometrie assimilabili a quelle in oggetto.

APPALTATORE: <u>Consorzio</u> <u>Soci</u> HIRPINIA AV SALINI IMPREGILO S.P.A. ASTALDI S.P.A.	ITINERARIO NAPOLI – BARI					
PROGETTAZIONE: <u>Mandatario</u> <u>Mandanti</u> ROCKSOIL S.P.A. NET ENGINEERING S.P.A. ALPINA S.P.A.	RADDOPPIO TRATTA APICE – ORSARA I LOTTO FUNZIONALE APICE – HIRPINIA					
PROGETTO ESECUTIVO RELAZIONE DI CALCOLO FONDAZIONI PILE P1, P2, P21, P22, P23 E P24	COMMESSA IF28	LOTTO 01	CODIFICA E ZZ CL	DOCUMENTO VI0403 002	REV. B	FOGLIO 101 di 161

12 ALLEGATO: TABULATI GROUP

12.1 PILA SLE

```

=====
GROUP for Windows, Version 2016.10.13
Serial Number : 228330872
Analysis of A Group of Piles
Subjected to Axial and Lateral Loading
(c) Copyright ENSOFT, Inc., 1987-2015
All Rights Reserved
=====

```

```

-----
Time and Date of Analysis
-----
Date: July 07, 2020    Time: 18:33:10

```

***** COMPUTATION RESULTS *****

New Group

***** LOAD CASES RESULTS *****

LOAD CASE : 1
CASE NAME : Load Case
LOAD TYPE : Special, Sp

REDUCTION FACTORS FOR CLOSELY-SPACED PILE GROUPS, COMBINED Y AND Z DIRECTIONS
ESTIMATED USING MOVEMENT IN THE DIRECTION OF PILE CAP DISPLACEMENTS

GROUP NO	P-FACTOR	Y-FACTOR
1	0.7218	1.0000
2	0.6876	1.0000
3	0.8661	1.0000
4	0.5344	1.0000
5	0.4962	1.0000
6	0.7148	1.0000
7	0.5845	1.0000
8	0.5444	1.0000
9	0.7555	1.0000

* TABLE L * COMPUTATION ON PILE CAP

* EQUIVALENT CONCENTRATED LOAD AT ORIGIN *

VERT. LOAD, KN	HOR. LOAD Y, KN	HOR. LOAD Z, KN
32155.0	-1369.00	1090.00
MOMENT X, KN- M	MOMENT Y, KN- M	MOMENT Z, KN- M
3.00000	17150.0	14443.5

* DISPLACEMENT OF GROUPED PILE FOUNDATION AT ORIGIN *

VERTICAL, M	HORIZONTAL Y, M	HORIZONTAL Z, M
1.69584E-03	-7.60934E-04	6.73358E-04

APPALTATORE: Consorzio Soci   	ITINERARIO NAPOLI – BARI RADDOPPIO TRATTA APICE – ORSARA I LOTTO FUNZIONALE APICE – HIRPINIA
PROGETTAZIONE: Mandataria Mandanti   	
PROGETTO ESECUTIVO RELAZIONE DI CALCOLO FONDAZIONI PILE P1, P2, P21, P22, P23 E P24	

ANGLE ROT. X,RAD ANGLE ROT. Y,RAD ANGLE ROT. Z,RAD
 2.06397E-07 7.92837E-05 7.21543E-05

THE GLOBAL STRUCTURAL COORDINATE SYSTEM

* PILE TOP DISPLACEMENTS *

PILE GROUP	DISP. X, M	DISP. Y, M	DISP. Z, M	ROT. X,RAD	ROT. Y,RAD	ROT. Z,RAD
*****	*****	*****	*****	*****	*****	*****
1	1.7279E-03	-7.6186E-04	6.7429E-04	2.0640E-07	7.9284E-05	7.2154E-05
2	2.0526E-03	-7.6186E-04	6.7336E-04	2.0640E-07	7.9284E-05	7.2154E-05
3	2.3773E-03	-7.6186E-04	6.7243E-04	2.0640E-07	7.9284E-05	7.2154E-05
4	1.3711E-03	-7.6093E-04	6.7429E-04	2.0640E-07	7.9284E-05	7.2154E-05
5	1.6958E-03	-7.6093E-04	6.7336E-04	2.0640E-07	7.9284E-05	7.2154E-05
6	2.0205E-03	-7.6093E-04	6.7243E-04	2.0640E-07	7.9284E-05	7.2154E-05
7	1.0144E-03	-7.6001E-04	6.7429E-04	2.0640E-07	7.9284E-05	7.2154E-05
8	1.3391E-03	-7.6001E-04	6.7336E-04	2.0640E-07	7.9284E-05	7.2154E-05
9	1.6638E-03	-7.6001E-04	6.7243E-04	2.0640E-07	7.9284E-05	7.2154E-05
MINIMUM	1.0144E-03	-7.6186E-04	6.7243E-04	2.0640E-07	7.9284E-05	7.2154E-05
Pile N.	7	1	3	1	1	1
MAXIMUM	2.3773E-03	-7.6001E-04	6.7429E-04	2.0640E-07	7.9284E-05	7.2154E-05
Pile N.	3	7	1	1	1	1

* PILE TOP REACTIONS *

PILE GROUP	FOR. X, KN	FOR. Y, KN	FOR. Z, KN	MOM X, KN- M	MOM Y, KN- M	MOM Z, KN- M
*****	*****	*****	*****	*****	*****	*****
1	3637.9	-161.34	128.86	0.072995	-283.17	-391.62
2	4297.2	-156.98	124.94	0.072995	-275.55	-383.36
3	4956.4	-178.34	142.47	0.072995	-308.15	-424.00
4	2913.5	-136.21	108.12	0.072995	-242.61	-341.57
5	3572.8	-130.57	103.19	0.072995	-232.54	-330.20
6	4232.0	-160.14	127.53	0.072995	-280.14	-389.13
7	2189.1	-143.07	114.05	0.072995	-254.22	-354.93
8	2848.4	-137.41	109.07	0.072995	-244.22	-343.70
9	3507.6	-164.93	131.76	0.072995	-287.98	-397.82
MINIMUM	2189.1	-178.34	103.19	0.072995	-308.15	-424.00
Pile N.	7	3	5	1	3	3
MAXIMUM	4956.4	-130.57	142.47	0.072995	-232.54	-330.20
Pile N.	3	5	3	1	5	5

THE PILE COORDINATE SYSTEM (LOCAL AXES)

* PILE TOP DISPLACEMENTS *

PILE GROUP	DISP. x, M	DISP. y, M	DISP. z, M	ROT. x,RAD	ROT. y,RAD	ROT. z,RAD
*****	*****	*****	*****	*****	*****	*****
1	1.7279E-03	-7.6186E-04	6.7429E-04	2.0640E-07	7.9284E-05	7.2154E-05
2	2.0526E-03	-7.6186E-04	6.7336E-04	2.0640E-07	7.9284E-05	7.2154E-05
3	2.3773E-03	-7.6186E-04	6.7243E-04	2.0640E-07	7.9284E-05	7.2154E-05
4	1.3711E-03	-7.6093E-04	6.7429E-04	2.0640E-07	7.9284E-05	7.2154E-05
5	1.6958E-03	-7.6093E-04	6.7336E-04	2.0640E-07	7.9284E-05	7.2154E-05
6	2.0205E-03	-7.6093E-04	6.7243E-04	2.0640E-07	7.9284E-05	7.2154E-05
7	1.0144E-03	-7.6001E-04	6.7429E-04	2.0640E-07	7.9284E-05	7.2154E-05
8	1.3391E-03	-7.6001E-04	6.7336E-04	2.0640E-07	7.9284E-05	7.2154E-05
9	1.6638E-03	-7.6001E-04	6.7243E-04	2.0640E-07	7.9284E-05	7.2154E-05
MINIMUM	1.0144E-03	-7.6186E-04	6.7243E-04	2.0640E-07	7.9284E-05	7.2154E-05
Pile N.	7	1	3	1	1	1
MAXIMUM	2.3773E-03	-7.6001E-04	6.7429E-04	2.0640E-07	7.9284E-05	7.2154E-05
Pile N.	3	7	1	1	1	1

* PILE TOP REACTIONS *

PILE GROUP	AXIAL, KN	LAT. y, KN	LAT. z, KN	MOM x, KN- M	MOM y, KN- M	MOM z, KN- M
*****	*****	*****	*****	*****	*****	*****
1	3637.9	-161.34	128.86	0.072995	-283.17	-391.62
2	4297.2	-156.98	124.94	0.072995	-275.55	-383.36
3	4956.4	-178.34	142.47	0.072995	-308.15	-424.00
4	2913.5	-136.21	108.12	0.072995	-242.61	-341.57
5	3572.8	-130.57	103.19	0.072995	-232.54	-330.20
6	4232.0	-160.14	127.53	0.072995	-280.14	-389.13
7	2189.1	-143.07	114.05	0.072995	-254.22	-354.93
8	2848.4	-137.41	109.07	0.072995	-244.22	-343.70
9	3507.6	-164.93	131.76	0.072995	-287.98	-397.82
MINIMUM	2189.1	-178.34	103.19	0.072995	-308.15	-424.00
Pile N.	7	3	5	1	3	3
MAXIMUM	4956.4	-130.57	142.47	0.072995	-232.54	-330.20
Pile N.	3	5	3	1	5	5

APPALTATORE:

Consorzio **Soci**



PROGETTAZIONE:

Mandatara **Mandanti**



PROGETTO ESECUTIVO

RELAZIONE DI CALCOLO FONDAZIONI PILE **P1, P2, P21, P22, P23 E P24**

ITINERARIO NAPOLI – BARI

RADDOPPIO TRATTA APICE – ORSARA

I LOTTO FUNZIONALE APICE – HIRPINIA

COMMESSA	LOTTO	CODIFICA	DOCUMENTO	REV.	FOGLIO
IF28	01	E ZZ CL	VI0403 002	B	103 di 161

PILE GROUP	STRESS, KN/ M**2
*****	*****
1	3517.2
2	3856.6
3	4386.7
4	2913.2
5	3240.7
6	3841.9
7	2556.4
8	2884.4
9	3467.1
MINIMUM	2556.4
Pile N.	7
MAXIMUM	4386.7
Pile N.	3

* EFFECTS FOR LATERALLY LOADED PILE *

* MINIMUM VALUES AND LOCATIONS *

PILE	DISPL. y-DIR	DISPL. z-DIR	MOMENT z-DIR	MOMENT y-DIR	SHEAR y-DIR	SHEAR z-DIR	SOIL REACT y-DIR	SOIL REACT z-DIR	TOTAL STRESS	FLEX. RIG. z-DIR	FLEX. RIG. y-DIR
*****	*****	*****	*****	*****	*****	*****	*****	*****	*****	*****	*****
	M	M	KN- M	KN- M	KN	KN	KN/ M	KN/ M	KN/ M**2	KN- M**2	KN- M**2
1	-7.6186E-04	-2.1315E-05	-219.60	-283.17	-161.37	-43.064	-81.835	-11.985	2058.6	7.8279E+06	7.8279E+06
x(M)	0.0000	10.200	5.4000	0.0000	0.0000	7.8000	4.2000	10.500	30.000	0.0000	0.0000
2	-7.6186E-04	-2.1575E-05	-215.49	-275.55	-157.01	-41.776	-78.950	-11.614	2431.7	7.8279E+06	7.8279E+06
x(M)	0.0000	10.200	5.4000	0.0000	0.0000	7.8000	4.2000	10.500	30.000	0.0000	0.0000
3	-7.6186E-04	-2.0266E-05	-235.30	-308.15	-178.38	-47.906	-93.418	-13.345	2804.8	7.8279E+06	7.8279E+06
x(M)	0.0000	9.9000	5.4000	0.0000	0.0000	7.5000	4.2000	10.200	30.000	0.0000	0.0000
4	-7.6093E-04	-2.2950E-05	-195.80	-242.61	-136.23	-35.762	-65.239	-9.8748	1648.7	7.8279E+06	7.8279E+06
x(M)	0.0000	10.800	5.7000	0.0000	0.0000	8.1000	4.2000	10.800	30.000	0.0000	0.0000
5	-7.6093E-04	-2.3359E-05	-190.29	-232.54	-130.59	-34.080	-61.635	-9.3319	2021.8	7.8279E+06	7.8279E+06
x(M)	0.0000	10.800	5.7000	0.0000	0.0000	8.1000	4.2000	10.800	30.000	0.0000	0.0000
6	-7.6093E-04	-2.1320E-05	-218.51	-280.14	-160.17	-42.709	-81.116	-11.881	2394.8	7.8279E+06	7.8279E+06
x(M)	0.0000	10.200	5.4000	0.0000	0.0000	7.8000	4.2000	10.500	30.000	0.0000	0.0000
7	-7.6001E-04	-2.2479E-05	-202.26	-254.22	-143.09	-37.759	-69.728	-10.502	1238.8	7.8279E+06	7.8279E+06
x(M)	0.0000	10.500	5.7000	0.0000	0.0000	8.1000	4.2000	10.800	30.000	0.0000	0.0000
8	-7.6001E-04	-2.2809E-05	-196.94	-244.22	-137.43	-36.126	-66.064	-9.9916	1611.9	7.8279E+06	7.8279E+06
x(M)	0.0000	10.500	5.7000	0.0000	0.0000	8.1000	4.2000	10.800	30.000	0.0000	0.0000
9	-7.6001E-04	-2.0958E-05	-222.92	-287.98	-164.96	-44.107	-84.356	-12.273	1984.9	7.8279E+06	7.8279E+06
x(M)	0.0000	10.200	5.4000	0.0000	0.0000	7.8000	4.2000	10.500	30.000	0.0000	0.0000
Min. Pile N.	-7.6186E-04 1	-2.3359E-05 5	-235.30 3	-308.15 3	-178.38 3	-47.906 3	-93.418 3	-13.345 3	1238.8 7	7.8279E+06 1	7.8279E+06 1





* MAXIMUM VALUES AND LOCATIONS *

PILE	DISPL. y-DIR	DISPL. z-DIR	MOMENT z-DIR	MOMENT y-DIR	SHEAR y-DIR	SHEAR z-DIR	SOIL REACT y-DIR	SOIL REACT z-DIR	TOTAL STRESS	FLEX. RIG. z-DIR	FLEX. RIG. y-DIR
*****	*****	*****	*****	*****	*****	*****	*****	*****	*****	*****	*****
	M	M	KN- M	KN- M	KN	KN	KN/ M	KN/ M	KN/ M**2	KN- M**2	KN- M**2
1	2.4517E-05	6.7429E-04	391.62	192.90	49.093	128.88	13.889	67.701	3517.2	7.8279E+06	7.8279E+06
x(M)	10.200	0.0000	0.0000	5.4000	7.8000	0.0000	10.500	4.2000	0.0000	0.0000	0.0000
2	2.4799E-05	6.7336E-04	383.36	189.29	47.599	124.97	13.507	65.175	3856.6	7.8279E+06	7.8279E+06
x(M)	10.500	0.0000	0.0000	5.4000	8.1000	0.0000	10.800	4.2000	0.0000	0.0000	0.0000
3	2.3401E-05	6.7243E-04	424.00	205.14	54.901	142.50	15.528	77.061	4386.7	7.8279E+06	7.8279E+06
x(M)	9.9000	0.0000	0.0000	5.1000	7.8000	0.0000	10.200	4.2000	0.0000	0.0000	0.0000
4	2.6352E-05	6.7429E-04	341.57	172.32	40.502	108.13	11.339	53.972	2913.2	7.8279E+06	7.8279E+06
x(M)	10.800	0.0000	0.0000	5.4000	8.1000	0.0000	10.800	4.2000	0.0000	0.0000	0.0000
5	2.6744E-05	6.7336E-04	330.20	167.52	38.718	103.21	10.684	50.873	3240.7	7.8279E+06	7.8279E+06
x(M)	10.800	0.0000	0.0000	5.7000	8.4000	0.0000	10.800	4.2000	0.0000	0.0000	0.0000
6	2.4552E-05	6.7243E-04	389.13	191.70	48.748	127.55	13.791	66.955	3841.9	7.8279E+06	7.8279E+06
x(M)	10.200	0.0000	0.0000	5.4000	7.8000	0.0000	10.800	4.2000	0.0000	0.0000	0.0000
7	2.5709E-05	6.7429E-04	354.93	178.33	42.899	114.06	12.101	57.804	2556.4	7.8279E+06	7.8279E+06
x(M)	10.800	0.0000	0.0000	5.4000	8.1000	0.0000	10.800	4.2000	0.0000	0.0000	0.0000
8	2.6206E-05	6.7336E-04	343.70	173.32	40.960	109.09	11.487	54.643	2884.4	7.8279E+06	7.8279E+06
x(M)	10.800	0.0000	0.0000	5.4000	8.1000	0.0000	10.800	4.2000	0.0000	0.0000	0.0000
9	2.4171E-05	6.7243E-04	397.82	195.51	50.401	131.78	14.257	69.757	3467.1	7.8279E+06	7.8279E+06
x(M)	10.200	0.0000	0.0000	5.4000	7.8000	0.0000	10.500	4.2000	0.0000	0.0000	0.0000
Max. Pile N.	2.6744E-05 5	6.7429E-04 1	424.00 3	205.14 3	54.901 3	142.50 3	15.528 3	77.061 3	4386.7 3	7.8279E+06 1	7.8279E+06 1

LOAD CASE : 2
CASE NAME : Load Case
LOAD TYPE : Special, Sp

REDUCTION FACTORS FOR CLOSELY-SPACED PILE GROUPS, COMBINED Y AND Z DIRECTIONS
ESTIMATED USING MOVEMENT IN THE DIRECTION OF PILE CAP DISPLACEMENTS

GROUP NO	P-FACTOR	Y-FACTOR
1	0.8353	1.0000
2	0.7800	1.0000

APPALTATORE: Consorzio Soci   	ITINERARIO NAPOLI – BARI RADDOPPIO TRATTA APICE – ORSARA I LOTTO FUNZIONALE APICE – HIRPINIA					
PROGETTAZIONE: Mandataria Mandanti   						
PROGETTO ESECUTIVO RELAZIONE DI CALCOLO FONDAZIONI PILE P1, P2, P21, P22, P23 E P24	COMMESSA IF28	LOTTO 01	CODIFICA E ZZ CL	DOCUMENTO VI0403 002	REV. B	FOGLIO 104 di 161

3	0.8661	1.0000
4	0.5692	1.0000
5	0.4962	1.0000
6	0.6127	1.0000
7	0.5845	1.0000
8	0.5079	1.0000
9	0.6277	1.0000

* TABLE L * COMPUTATION ON PILE CAP

* EQUIVALENT CONCENTRATED LOAD AT ORIGIN *

VERT. LOAD, KN 24933.0	HOR. LOAD Y, KN -338.000	HOR. LOAD Z, KN 821.000
MOMENT X, KN- M 0.00000	MOMENT Y, KN- M 12766.5	MOMENT Z, KN- M 4031.00

* DISPLACEMENT OF GROUPED PILE FOUNDATION AT ORIGIN *

VERTICAL, M 1.30062E-03	HORIZONTAL Y, M -1.93873E-04	HORIZONTAL Z, M 5.05757E-04
ANGLE ROT. X, RAD -8.92810E-07	ANGLE ROT. Y, RAD 5.91274E-05	ANGLE ROT. Z, RAD 1.96120E-05

THE GLOBAL STRUCTURAL COORDINATE SYSTEM

* PILE TOP DISPLACEMENTS *

PILE GROUP	DISP. X, M	DISP. Y, M	DISP. Z, M	ROT. X, RAD	ROT. Y, RAD	ROT. Z, RAD
*****	*****	*****	*****	*****	*****	*****
1	1.4784E-03	-1.8986E-04	5.0174E-04	-8.9281E-07	5.9127E-05	1.9612E-05
2	1.5667E-03	-1.8986E-04	5.0576E-04	-8.9281E-07	5.9127E-05	1.9612E-05
3	1.6550E-03	-1.8986E-04	5.0977E-04	-8.9281E-07	5.9127E-05	1.9612E-05
4	1.2124E-03	-1.9387E-04	5.0174E-04	-8.9281E-07	5.9127E-05	1.9612E-05
5	1.3006E-03	-1.9387E-04	5.0576E-04	-8.9281E-07	5.9127E-05	1.9612E-05
6	1.3889E-03	-1.9387E-04	5.0977E-04	-8.9281E-07	5.9127E-05	1.9612E-05
7	9.4629E-04	-1.9789E-04	5.0174E-04	-8.9281E-07	5.9127E-05	1.9612E-05
8	1.0345E-03	-1.9789E-04	5.0576E-04	-8.9281E-07	5.9127E-05	1.9612E-05
9	1.1228E-03	-1.9789E-04	5.0977E-04	-8.9281E-07	5.9127E-05	1.9612E-05
MINIMUM	9.4629E-04	-1.9789E-04	5.0174E-04	-8.9281E-07	5.9127E-05	1.9612E-05
Pile N.	7	7	1	1	1	1
MAXIMUM	1.6550E-03	-1.8986E-04	5.0977E-04	-8.9281E-07	5.9127E-05	1.9612E-05
Pile N.	3	1	3	1	1	1

* PILE TOP REACTIONS *

PILE GROUP	FOR. X, KN	FOR. Y, KN	FOR. Z, KN	MOM X, KN- M	MOM Y, KN- M	MOM Z, KN- M
*****	*****	*****	*****	*****	*****	*****
1	3131.4	-42.137	104.44	-0.3158	-226.18	-97.219
2	3310.6	-40.537	101.61	-0.3158	-222.37	-94.240
3	3489.8	-42.991	109.24	-0.3158	-237.93	-98.821
4	2591.1	-34.988	83.536	-0.3158	-186.22	-84.753
5	2770.3	-32.349	78.010	-0.3158	-176.40	-79.428
6	2949.5	-36.473	89.419	-0.3158	-200.39	-87.722
7	2050.9	-36.614	84.891	-0.3158	-188.80	-89.204
8	2230.1	-33.806	79.132	-0.3158	-178.58	-83.553
9	2409.3	-38.106	90.724	-0.3158	-202.84	-92.175
MINIMUM	2050.9	-42.991	78.010	-0.3158	-237.93	-98.821
Pile N.	7	3	5	1	3	3
MAXIMUM	3489.8	-32.349	109.24	-0.3158	-176.40	-79.428
Pile N.	3	5	3	1	5	5

THE PILE COORDINATE SYSTEM (LOCAL AXES)

* PILE TOP DISPLACEMENTS *

PILE GROUP	DISP. x, M	DISP. y, M	DISP. z, M	ROT. x, RAD	ROT. y, RAD	ROT. z, RAD
*****	*****	*****	*****	*****	*****	*****
1	1.4784E-03	-1.8986E-04	5.0174E-04	-8.9281E-07	5.9127E-05	1.9612E-05
2	1.5667E-03	-1.8986E-04	5.0576E-04	-8.9281E-07	5.9127E-05	1.9612E-05
3	1.6550E-03	-1.8986E-04	5.0977E-04	-8.9281E-07	5.9127E-05	1.9612E-05
4	1.2124E-03	-1.9387E-04	5.0174E-04	-8.9281E-07	5.9127E-05	1.9612E-05
5	1.3006E-03	-1.9387E-04	5.0576E-04	-8.9281E-07	5.9127E-05	1.9612E-05
6	1.3889E-03	-1.9387E-04	5.0977E-04	-8.9281E-07	5.9127E-05	1.9612E-05

APPALTATORE:

Consorzio

Soci



ITINERARIO NAPOLI – BARI

PROGETTAZIONE:

Mandataria

Mandanti



RADDOPPIO TRATTA APICE – ORSARA
I LOTTO FUNZIONALE APICE – HIRPINIA

PROGETTO ESECUTIVO

RELAZIONE DI CALCOLO FONDAZIONI PILE P1, P2, P21, P22, P23 E P24

COMMESSA	LOTTO	CODIFICA	DOCUMENTO	REV.	FOGLIO
IF28	01	E ZZ CL	VI0403 002	B	105 di 161

7	9.4629E-04	-1.9789E-04	5.0174E-04	-8.9281E-07	5.9127E-05	1.9612E-05
8	1.0345E-03	-1.9789E-04	5.0576E-04	-8.9281E-07	5.9127E-05	1.9612E-05
9	1.1228E-03	-1.9789E-04	5.0977E-04	-8.9281E-07	5.9127E-05	1.9612E-05
MINIMUM	9.4629E-04	-1.9789E-04	5.0174E-04	-8.9281E-07	5.9127E-05	1.9612E-05
Pile N.	7	7	1	1	1	1
MAXIMUM	1.6550E-03	-1.8986E-04	5.0977E-04	-8.9281E-07	5.9127E-05	1.9612E-05
Pile N.	3	1	3	1	1	1

* PILE TOP REACTIONS *

PILE GROUP	AXIAL, KN	LAT. y, KN	LAT. z, KN	MOM x, KN- M	MOM y, KN- M	MOM z, KN- M
1	3131.4	-42.137	104.44	-0.3158	-226.18	-97.219
2	3310.6	-40.537	101.61	-0.3158	-222.37	-94.240
3	3489.8	-42.991	109.24	-0.3158	-237.93	-98.821
4	2591.1	-34.988	83.536	-0.3158	-186.22	-84.753
5	2770.3	-32.349	78.010	-0.3158	-176.40	-79.428
6	2949.5	-36.473	89.419	-0.3158	-200.39	-87.722
7	2050.9	-36.614	84.891	-0.3158	-188.80	-89.204
8	2230.1	-33.806	79.132	-0.3158	-178.58	-83.553
9	2409.3	-38.106	90.724	-0.3158	-202.84	-92.175
MINIMUM	2050.9	-42.991	78.010	-0.3158	-237.93	-98.821
Pile N.	7	3	5	1	3	3
MAXIMUM	3489.8	-32.349	109.24	-0.3158	-176.40	-79.428
Pile N.	3	5	3	1	5	5

PILE GROUP	STRESS, KN/ M**2
1	2515.0
2	2602.3
3	2752.4
4	2083.8
5	2151.6
6	2329.3
7	1790.8
8	1857.0
9	2035.8
MINIMUM	1790.8
Pile N.	7
MAXIMUM	2752.4
Pile N.	3

* EFFECTS FOR LATERALLY LOADED PILE *

* MINIMUM VALUES AND LOCATIONS *

PILE	DISPL. y-DIR	DISPL. z-DIR	MOMENT z-DIR	MOMENT y-DIR	SHEAR y-DIR	SHEAR z-DIR	SOIL REACT y-DIR	SOIL REACT z-DIR	TOTAL STRESS	FLEX. RIG. z-DIR	FLEX. RIG. y-DIR
	M	M	KN- M	KN- M	KN	KN	KN/ M	KN/ M	KN/ M**2	KN- M**2	KN- M**2
1	-1.8986E-04	-1.5260E-05	-57.600	-226.18	-42.143	-34.906	-22.130	-9.7336	1772.0	7.8279E+06	7.8279E+06
x (M)	0.0000	9.9000	5.4000	0.0000	0.0000	7.5000	4.2000	10.200	30.000	0.0000	0.0000
2	-1.8986E-04	-1.5657E-05	-56.176	-222.37	-40.543	-33.808	-21.054	-9.4102	1873.4	7.8279E+06	7.8279E+06
x (M)	0.0000	9.9000	5.4000	0.0000	0.0000	7.8000	4.2000	10.500	30.000	0.0000	0.0000
3	-1.8986E-04	-1.5372E-05	-58.356	-237.93	-42.998	-36.305	-22.715	-10.130	1974.8	7.8279E+06	7.8279E+06
x (M)	0.0000	9.9000	5.4000	0.0000	0.0000	7.5000	4.2000	10.200	30.000	0.0000	0.0000
4	-1.9387E-04	-1.6835E-05	-50.963	-186.22	-34.992	-27.659	-17.114	-7.6771	1466.3	7.8279E+06	7.8279E+06
x (M)	0.0000	10.500	5.7000	0.0000	0.0000	8.1000	4.2000	10.800	30.000	0.0000	0.0000
5	-1.9387E-04	-1.7540E-05	-48.409	-176.40	-32.353	-25.578	-15.411	-7.0074	1567.7	7.8279E+06	7.8279E+06
x (M)	0.0000	10.800	5.7000	0.0000	0.0000	8.1000	4.2000	10.800	30.000	0.0000	0.0000
6	-1.9387E-04	-1.6821E-05	-52.350	-200.39	-36.478	-29.393	-18.092	-8.2043	1669.1	7.8279E+06	7.8279E+06
x (M)	0.0000	10.500	5.7000	0.0000	0.0000	8.1000	4.2000	10.800	30.000	0.0000	0.0000
7	-1.9789E-04	-1.6723E-05	-52.570	-188.80	-36.618	-28.092	-17.934	-7.8121	1160.6	7.8279E+06	7.8279E+06
x (M)	0.0000	10.500	5.7000	0.0000	0.0000	8.1000	4.2000	10.800	30.000	0.0000	0.0000
8	-1.9789E-04	-1.7437E-05	-49.875	-178.58	-33.809	-25.955	-16.115	-7.1311	1262.0	7.8279E+06	7.8279E+06
x (M)	0.0000	10.800	5.7000	0.0000	0.0000	8.1000	4.2000	10.800	30.000	0.0000	0.0000
9	-1.9789E-04	-1.6700E-05	-53.950	-202.84	-38.110	-29.813	-18.919	-8.3253	1363.4	7.8279E+06	7.8279E+06
x (M)	0.0000	10.500	5.7000	0.0000	0.0000	7.8000	4.2000	10.800	30.000	0.0000	0.0000
Min.	-1.9789E-04	-1.7540E-05	-58.356	-237.93	-42.998	-36.305	-22.715	-10.130	1160.6	7.8279E+06	7.8279E+06
Pile N.	7	5	3	3	3	3	3	3	7	1	1

* MAXIMUM VALUES AND LOCATIONS *

PILE	DISPL. y-DIR	DISPL. z-DIR	MOMENT z-DIR	MOMENT y-DIR	SHEAR y-DIR	SHEAR z-DIR	SOIL REACT y-DIR	SOIL REACT z-DIR	TOTAL STRESS	FLEX. RIG. z-DIR	FLEX. RIG. y-DIR
	M	M	KN- M	KN- M	KN	KN	KN/ M	KN/ M	KN/ M**2	KN- M**2	KN- M**2
1	5.8366E-06	5.0174E-04	97.219	151.12	13.306	104.46	3.7417	56.023	2515.0	7.8279E+06	7.8279E+06
x (M)	9.9000	0.0000	0.0000	5.4000	7.8000	0.0000	10.200	4.2000	0.0000	0.0000	0.0000
2	5.9364E-06	5.0576E-04	94.240	148.79	12.784	101.62	3.5934	53.865	2602.3	7.8279E+06	7.8279E+06
x (M)	10.200	0.0000	0.0000	5.4000	7.8000	0.0000	10.500	4.2000	0.0000	0.0000	0.0000
3	5.7848E-06	5.0977E-04	98.821	155.62	13.584	109.25	3.8283	58.757	2752.4	7.8279E+06	7.8279E+06
x (M)	9.9000	0.0000	0.0000	5.4000	7.8000	0.0000	10.200	4.2000	0.0000	0.0000	0.0000
4	6.5723E-06	5.0174E-04	84.753	131.38	10.740	83.545	3.0121	42.104	2083.8	7.8279E+06	7.8279E+06

APPALTATORE: Consorzio Soci   	ITINERARIO NAPOLI – BARI RADDOPPIO TRATTA APICE – ORSARA I LOTTO FUNZIONALE APICE – HIRPINIA					
PROGETTAZIONE: Mandataria Mandanti   						
PROGETTO ESECUTIVO RELAZIONE DI CALCOLO FONDAZIONI PILE P1, P2, P21, P22, P23 E P24		COMMESSA IF28	LOTTO 01	CODIFICA E ZZ CL	DOCUMENTO VI0403 002	REV. B

x(M)	10.800	0.0000	0.0000	5.4000	8.1000	0.0000	10.800	4.2000	0.0000	0.0000	0.0000
5	6.7844E-06	5.0576E-04	79.428	125.83	9.8331	78.019	2.7104	38.309	2151.6	7.8279E+06	7.8279E+06
x(M)	10.800	0.0000	0.0000	5.7000	8.4000	0.0000	10.800	4.2000	0.0000	0.0000	0.0000
6	6.4691E-06	5.0977E-04	87.722	137.31	11.253	89.430	3.1704	45.497	2329.3	7.8279E+06	7.8279E+06
x(M)	10.500	0.0000	0.0000	5.4000	8.1000	0.0000	10.800	4.2000	0.0000	0.0000	0.0000
7	6.6747E-06	5.0174E-04	89.204	132.71	11.153	84.899	3.1379	42.970	1790.8	7.8279E+06	7.8279E+06
x(M)	10.500	0.0000	0.0000	5.4000	8.1000	0.0000	10.800	4.2000	0.0000	0.0000	0.0000
8	6.9000E-06	5.0576E-04	83.553	126.88	10.185	79.139	2.8218	39.010	1857.0	7.8279E+06	7.8279E+06
x(M)	10.800	0.0000	0.0000	5.7000	8.4000	0.0000	10.800	4.2000	0.0000	0.0000	0.0000
9	6.5720E-06	5.0977E-04	92.175	138.55	11.663	90.733	3.2937	46.336	2035.8	7.8279E+06	7.8279E+06
x(M)	10.500	0.0000	0.0000	5.4000	8.1000	0.0000	10.800	4.2000	0.0000	0.0000	0.0000
Max.	6.9000E-06	5.0977E-04	98.821	155.62	13.584	109.25	3.8283	58.757	2752.4	7.8279E+06	7.8279E+06
Pile N.	8	3	3	3	3	3	3	3	3	1	1

LOAD CASE : 3
CASE NAME : Load Case
LOAD TYPE : Special, Sp

REDUCTION FACTORS FOR CLOSELY-SPACED PILE GROUPS, COMBINED Y AND Z DIRECTIONS
ESTIMATED USING MOVEMENT IN THE DIRECTION OF PILE CAP DISPLACEMENTS

GROUP NO	P-FACTOR	Y-FACTOR
1	0.7549	1.0000
2	0.7143	1.0000
3	0.8661	1.0000
4	0.5442	1.0000
5	0.4962	1.0000
6	0.6881	1.0000
7	0.5845	1.0000
8	0.5346	1.0000
9	0.7224	1.0000

* TABLE L * COMPUTATION ON PILE CAP

* EQUIVALENT CONCENTRATED LOAD AT ORIGIN *

VERT. LOAD, KN	HOR. LOAD Y, KN	HOR. LOAD Z, KN
29211.0	-959.000	873.000
MOMENT X, KN- M	MOMENT Y, KN- M	MOMENT Z, KN- M
0.00000	18986.5	10268.5

* DISPLACEMENT OF GROUPED PILE FOUNDATION AT ORIGIN *

VERTICAL, M	HORIZONTAL Y, M	HORIZONTAL Z, M
1.53473E-03	-5.34541E-04	6.01417E-04
ANGLE ROT. X, RAD	ANGLE ROT. Y, RAD	ANGLE ROT. Z, RAD
-5.29576E-07	8.37799E-05	5.11199E-05

THE GLOBAL STRUCTURAL COORDINATE SYSTEM

* PILE TOP DISPLACEMENTS *

PILE GROUP	DISP. X, M	DISP. Y, M	DISP. Z, M	ROT. X, RAD	ROT. Y, RAD	ROT. Z, RAD
1	1.6817E-03	-5.3216E-04	5.9903E-04	-5.2958E-07	8.3780E-05	5.1120E-05
2	1.9117E-03	-5.3216E-04	6.0142E-04	-5.2958E-07	8.3780E-05	5.1120E-05
3	2.1418E-03	-5.3216E-04	6.0380E-04	-5.2958E-07	8.3780E-05	5.1120E-05
4	1.3047E-03	-5.3454E-04	5.9903E-04	-5.2958E-07	8.3780E-05	5.1120E-05
5	1.5347E-03	-5.3454E-04	6.0142E-04	-5.2958E-07	8.3780E-05	5.1120E-05
6	1.7648E-03	-5.3454E-04	6.0380E-04	-5.2958E-07	8.3780E-05	5.1120E-05
7	9.2768E-04	-5.3692E-04	5.9903E-04	-5.2958E-07	8.3780E-05	5.1120E-05
8	1.1577E-03	-5.3692E-04	6.0142E-04	-5.2958E-07	8.3780E-05	5.1120E-05
9	1.3878E-03	-5.3692E-04	6.0380E-04	-5.2958E-07	8.3780E-05	5.1120E-05
MINIMUM	9.2768E-04	-5.3692E-04	5.9903E-04	-5.2958E-07	8.3780E-05	5.1120E-05
Pile N.	7	7	1	1	1	1
MAXIMUM	2.1418E-03	-5.3216E-04	6.0380E-04	-5.2958E-07	8.3780E-05	5.1120E-05
Pile N.	3	1	3	1	1	1

* PILE TOP REACTIONS *

PILE GROUP	FOR. X, KN	FOR. Y, KN	FOR. Z, KN	MOM X, KN- M	MOM Y, KN- M	MOM Z, KN- M
1	3544.1	-114.98	105.38	-0.1873	-202.10	-276.11

APPALTATORE:

Consorzio

Soci



ITINERARIO NAPOLI – BARI

PROGETTAZIONE:

Mandataria

Mandanti



RADDOPPIO TRATTA APICE – ORSARA
I LOTTO FUNZIONALE APICE – HIRPINIA

PROGETTO ESECUTIVO

RELAZIONE DI CALCOLO FONDAZIONI PILE P1, P2, P21, P22, P23
E P24

COMMESSA	LOTTO	CODIFICA	DOCUMENTO	REV.	FOGLIO
IF28	01	E ZZ CL	VI0403 002	B	107 di 161

2	4011.1	-111.47	102.55	-0.1873	-197.75	-269.46
3	4478.2	-124.03	116.03	-0.1873	-223.51	-293.23
4	2778.6	-96.400	86.172	-0.1873	-165.31	-240.33
5	3245.7	-91.468	81.883	-0.1873	-157.65	-230.36
6	3712.7	-109.88	100.94	-0.1873	-195.49	-267.14
7	2013.1	-101.05	90.150	-0.1873	-172.92	-250.26
8	2480.2	-96.066	85.850	-0.1873	-165.36	-240.32
9	2947.3	-113.66	104.05	-0.1873	-201.18	-275.09
MINIMUM	2013.1	-124.03	81.883	-0.1873	-223.51	-293.23
Pile N.	7	3	5	1	3	3
MAXIMUM	4478.2	-91.468	116.03	-0.1873	-157.65	-230.36
Pile N.	3	5	3	1	5	5

THE PILE COORDINATE SYSTEM (LOCAL AXES)

* PILE TOP DISPLACEMENTS *

PILE GROUP	DISP. x, M	DISP. y, M	DISP. z, M	ROT. x, RAD	ROT. y, RAD	ROT. z, RAD
1	1.6817E-03	-5.3216E-04	5.9903E-04	-5.2958E-07	8.3780E-05	5.1120E-05
2	1.9117E-03	-5.3216E-04	6.0142E-04	-5.2958E-07	8.3780E-05	5.1120E-05
3	2.1418E-03	-5.3216E-04	6.0380E-04	-5.2958E-07	8.3780E-05	5.1120E-05
4	1.3047E-03	-5.3454E-04	5.9903E-04	-5.2958E-07	8.3780E-05	5.1120E-05
5	1.5347E-03	-5.3454E-04	6.0142E-04	-5.2958E-07	8.3780E-05	5.1120E-05
6	1.7648E-03	-5.3454E-04	6.0380E-04	-5.2958E-07	8.3780E-05	5.1120E-05
7	9.2768E-04	-5.3692E-04	5.9903E-04	-5.2958E-07	8.3780E-05	5.1120E-05
8	1.1577E-03	-5.3692E-04	6.0142E-04	-5.2958E-07	8.3780E-05	5.1120E-05
9	1.3878E-03	-5.3692E-04	6.0380E-04	-5.2958E-07	8.3780E-05	5.1120E-05
MINIMUM	9.2768E-04	-5.3692E-04	5.9903E-04	-5.2958E-07	8.3780E-05	5.1120E-05
Pile N.	7	3	5	1	3	3
MAXIMUM	2.1418E-03	-5.3216E-04	6.0380E-04	-5.2958E-07	8.3780E-05	5.1120E-05
Pile N.	3	1	3	1	1	1

* PILE TOP REACTIONS *

PILE GROUP	AXIAL, KN	LAT. y, KN	LAT. z, KN	MOM x, KN- M	MOM y, KN- M	MOM z, KN- M
1	3544.1	-114.98	105.38	-0.1873	-202.10	-276.11
2	4011.1	-111.47	102.55	-0.1873	-197.75	-269.46
3	4478.2	-124.03	116.03	-0.1873	-223.51	-293.23
4	2778.6	-96.400	86.172	-0.1873	-165.31	-240.33
5	3245.7	-91.468	81.883	-0.1873	-157.65	-230.36
6	3712.7	-109.88	100.94	-0.1873	-195.49	-267.14
7	2013.1	-101.05	90.150	-0.1873	-172.92	-250.26
8	2480.2	-96.066	85.850	-0.1873	-165.36	-240.32
9	2947.3	-113.66	104.05	-0.1873	-201.18	-275.09
MINIMUM	2013.1	-124.03	81.883	-0.1873	-223.51	-293.23
Pile N.	7	3	5	1	3	3
MAXIMUM	4478.2	-91.468	116.03	-0.1873	-157.65	-230.36
Pile N.	3	5	3	1	5	5

PILE GROUP STRESS, KN/ M**2

1	3038.2
2	3278.6
3	3646.9
4	2452.7
5	2679.1
6	3100.0
7	2057.3
8	2283.9
9	2696.4
MINIMUM	2057.3
Pile N.	7
MAXIMUM	3646.9
Pile N.	3

* EFFECTS FOR LATERALLY LOADED PILE *

* MINIMUM VALUES AND LOCATIONS *

PILE	DISPL. y-DIR M	DISPL. z-DIR M	MOMENT z-DIR KN- M	MOMENT y-DIR KN- M	SHEAR y-DIR KN	SHEAR z-DIR KN	SOIL REACT y-DIR KN/ M	SOIL REACT z-DIR KN/ M	TOTAL STRESS KN/ M**2	FLEX. RIG. z-DIR KN- M**2	FLEX. RIG. y-DIR KN- M**2
x(M)	-5.3216E-04	-1.8462E-05	-155.99	-202.10	-115.00	-38.999	-58.836	-10.675	2005.5	7.8279E+06	7.8279E+06
	0.0000	9.9000	5.4000	0.0000	0.0000	7.5000	4.2000	10.200	30.000	0.0000	0.0000
x(M)	-5.3216E-04	-1.8795E-05	-152.72	-197.75	-111.49	-37.875	-56.495	-10.370	2269.8	7.8279E+06	7.8279E+06
	0.0000	9.9000	5.4000	0.0000	0.0000	7.8000	4.2000	10.500	30.000	0.0000	0.0000
x(M)	-5.3216E-04	-1.7954E-05	-164.23	-223.51	-124.05	-42.690	-64.998	-11.701	2534.1	7.8279E+06	7.8279E+06
	0.0000	9.6000	5.4000	0.0000	0.0000	7.5000	4.2000	30.000	9.9000	0.0000	0.0000
x(M)	-5.3454E-04	-2.0092E-05	-138.47	-165.31	-96.413	-32.019	-46.356	-8.7262	1572.4	7.8279E+06	7.8279E+06

APPALTATORE: Consorzio  Soci  		ITINERARIO NAPOLI – BARI					
PROGETTAZIONE: Mandataria  Mandanti  		RADDOPPIO TRATTA APICE – ORSARA I LOTTO FUNZIONALE APICE – HIRPINIA					
PROGETTO ESECUTIVO RELAZIONE DI CALCOLO FONDAZIONI PILE P1, P2, P21, P22, P23 E P24		COMMESSA IF28	LOTTO 01	CODIFICA E ZZ CL	DOCUMENTO VI0403 002	REV. B	FOGLIO 108 di 161

x(M)	0.0000	10.500	5.7000	0.0000	0.0000	7.8000	4.2000	10.800	30.000	0.0000	0.0000
5	-5.3454E-04	-2.0609E-05	-133.65	-157.65	-91.483	-30.443	-43.192	-8.2294	1836.7	7.8279E+06	7.8279E+06
x(M)	0.0000	10.500	5.7000	0.0000	0.0000	8.1000	4.2000	10.800	30.000	0.0000	0.0000
6	-5.3454E-04	-1.9060E-05	-151.19	-195.49	-109.90	-37.228	-55.273	-10.191	2101.0	7.8279E+06	7.8279E+06
x(M)	0.0000	10.200	5.4000	0.0000	0.0000	7.8000	4.2000	10.500	30.000	0.0000	0.0000
7	-5.3692E-04	-1.9683E-05	-142.87	-172.92	-101.06	-33.463	-49.218	-9.1250	1139.2	7.8279E+06	7.8279E+06
x(M)	0.0000	10.500	5.7000	0.0000	0.0000	7.8000	4.2000	10.800	30.000	0.0000	0.0000
8	-5.3692E-04	-2.0261E-05	-138.15	-165.36	-96.077	-31.783	-45.992	-8.6594	1403.5	7.8279E+06	7.8279E+06
x(M)	0.0000	10.500	5.7000	0.0000	0.0000	8.1000	4.2000	10.800	30.000	0.0000	0.0000
9	-5.3692E-04	-1.8809E-05	-154.77	-201.18	-113.68	-38.241	-57.625	-10.478	1667.8	7.8279E+06	7.8279E+06
x(M)	0.0000	9.9000	5.4000	0.0000	0.0000	7.8000	4.2000	10.500	30.000	0.0000	0.0000
Min.	-5.3692E-04	-2.0609E-05	-164.23	-223.51	-124.05	-42.690	-64.998	-11.701	1139.2	7.8279E+06	7.8279E+06
Pile N.	7	5	3	3	3	3	3	3	7	1	1

* MAXIMUM VALUES AND LOCATIONS *

PILE	DISPL. y-DIR M	DISPL. z-DIR M	MOMENT z-DIR KN- M	MOMENT y-DIR KN- M	SHEAR y-DIR KN	SHEAR z-DIR KN	SOIL REACT y-DIR KN/ M	SOIL REACT z-DIR KN/ M	TOTAL STRESS KN/ M**2	FLEX. RIG. z-DIR KN- M**2	FLEX. RIG. y-DIR KN- M**2
*****	*****	*****	*****	*****	*****	*****	*****	*****	*****	*****	*****
1	1.6912E-05	5.9903E-04	276.11	173.38	35.258	105.39	9.9651	57.948	3038.2	7.8279E+06	7.8279E+06
x(M)	10.200	0.0000	0.0000	5.1000	7.8000	0.0000	10.500	4.2000	0.0000	0.0000	0.0000
2	1.7154E-05	6.0142E-04	269.46	170.61	34.057	102.56	9.6235	55.932	3278.6	7.8279E+06	7.8279E+06
x(M)	10.200	0.0000	0.0000	5.1000	7.8000	0.0000	10.800	4.2000	0.0000	0.0000	0.0000
3	1.6322E-05	6.0380E-04	293.23	183.62	38.299	116.05	10.826	64.842	3646.9	7.8279E+06	7.8279E+06
x(M)	9.9000	0.0000	0.0000	5.1000	7.8000	0.0000	10.200	4.2000	0.0000	0.0000	0.0000
4	1.8422E-05	5.9903E-04	240.33	154.37	28.798	86.181	8.0724	45.240	2452.7	7.8279E+06	7.8279E+06
x(M)	10.800	0.0000	0.0000	5.4000	8.1000	0.0000	10.800	4.2000	0.0000	0.0000	0.0000
5	1.8773E-05	6.0142E-04	230.36	149.97	27.182	81.893	7.4998	42.354	2679.1	7.8279E+06	7.8279E+06
x(M)	10.800	0.0000	0.0000	5.4000	8.4000	0.0000	10.800	4.2000	0.0000	0.0000	0.0000
6	1.7372E-05	6.0380E-04	267.14	168.92	33.380	100.95	9.4655	54.706	3100.0	7.8279E+06	7.8279E+06
x(M)	10.500	0.0000	0.0000	5.1000	7.8000	0.0000	10.800	4.2000	0.0000	0.0000	0.0000
7	1.8156E-05	5.9903E-04	250.26	158.26	30.301	90.156	8.5454	47.801	2057.3	7.8279E+06	7.8279E+06
x(M)	10.800	0.0000	0.0000	5.4000	8.1000	0.0000	10.800	4.2000	0.0000	0.0000	0.0000
8	1.8581E-05	6.0142E-04	240.32	153.99	28.572	85.857	7.9975	44.882	2283.9	7.8279E+06	7.8279E+06
x(M)	10.800	0.0000	0.0000	5.4000	8.1000	0.0000	10.800	4.2000	0.0000	0.0000	0.0000
9	1.7259E-05	6.0380E-04	275.09	171.95	34.592	104.06	9.7831	56.741	2696.4	7.8279E+06	7.8279E+06
x(M)	10.200	0.0000	0.0000	5.1000	7.8000	0.0000	10.500	4.2000	0.0000	0.0000	0.0000
Max.	1.8773E-05	6.0380E-04	293.23	183.62	38.299	116.05	10.826	64.842	3646.9	7.8279E+06	7.8279E+06
Pile N.	5	3	3	3	3	3	3	3	3	1	1

LOAD CASE : 4
CASE NAME : Load Case
LOAD TYPE : Special, Sp

REDUCTION FACTORS FOR CLOSELY-SPACED PILE GROUPS, COMBINED Y AND Z DIRECTIONS
ESTIMATED USING MOVEMENT IN THE DIRECTION OF PILE CAP DISPLACEMENTS

GROUP NO	P-FACTOR	Y-FACTOR
1	0.6127	1.0000
2	0.6010	1.0000
3	0.8661	1.0000
4	0.5039	1.0000
5	0.4962	1.0000
6	0.7891	1.0000
7	0.5845	1.0000
8	0.5727	1.0000
9	0.8464	1.0000





* TABLE L * COMPUTATION ON PILE CAP

* EQUIVALENT CONCENTRATED LOAD AT ORIGIN *

VERT. LOAD, KN	HOR. LOAD Y, KN	HOR. LOAD Z, KN
29727.0	-2605.00	718.000
MOMENT X, KN- M	MOMENT Y, KN- M	MOMENT Z, KN- M
248.000	11486.0	30953.5

* DISPLACEMENT OF GROUPED PILE FOUNDATION AT ORIGIN *

VERTICAL, M	HORIZONTAL Y, M	HORIZONTAL Z, M
1.56326E-03	-1.50770E-03	4.52605E-04
ANGLE ROT. X, RAD	ANGLE ROT. Y, RAD	ANGLE ROT. Z, RAD
5.92564E-06	5.29280E-05	1.50782E-04

APPALTATORE: Consorzio  Soci  		ITINERARIO NAPOLI – BARI RADDOPPIO TRATTA APICE – ORSARA I LOTTO FUNZIONALE APICE – HIRPINIA					
PROGETTAZIONE: Mandataria  Mandanti  							
PROGETTO ESECUTIVO RELAZIONE DI CALCOLO FONDAZIONI PILE P1, P2, P21, P22, P23 E P24							COMMESSA IF28

THE GLOBAL STRUCTURAL COORDINATE SYSTEM

* PILE TOP DISPLACEMENTS *

PILE GROUP	DISP. X, M	DISP. Y, M	DISP. Z, M	ROT. X,RAD	ROT. Y,RAD	ROT. Z,RAD
1	1.1229E-03	-1.5344E-03	4.7927E-04	5.9256E-06	5.2928E-05	1.5078E-04
2	1.8014E-03	-1.5344E-03	4.5261E-04	5.9256E-06	5.2928E-05	1.5078E-04
3	2.4800E-03	-1.5344E-03	4.2594E-04	5.9256E-06	5.2928E-05	1.5078E-04
4	8.8474E-04	-1.5077E-03	4.7927E-04	5.9256E-06	5.2928E-05	1.5078E-04
5	1.5633E-03	-1.5077E-03	4.5261E-04	5.9256E-06	5.2928E-05	1.5078E-04
6	2.2418E-03	-1.5077E-03	4.2594E-04	5.9256E-06	5.2928E-05	1.5078E-04
7	6.4657E-04	-1.4810E-03	4.7927E-04	5.9256E-06	5.2928E-05	1.5078E-04
8	1.3251E-03	-1.4810E-03	4.5261E-04	5.9256E-06	5.2928E-05	1.5078E-04
9	2.0036E-03	-1.4810E-03	4.2594E-04	5.9256E-06	5.2928E-05	1.5078E-04
MINIMUM	6.4657E-04	-1.5344E-03	4.2594E-04	5.9256E-06	5.2928E-05	1.5078E-04
Pile N.	7	1	3	1	1	1
MAXIMUM	2.4800E-03	-1.4810E-03	4.7927E-04	5.9256E-06	5.2928E-05	1.5078E-04
Pile N.	3	7	1	1	1	1

* PILE TOP REACTIONS *

PILE GROUP	FOR. X, KN	FOR. Y, KN	FOR. Z, KN	MOM X, KN- M	MOM Y, KN- M	MOM Z, KN- M
1	2409.5	-287.60	84.883	2.0957	-195.97	-701.80
2	3787.2	-284.36	76.746	2.0957	-171.75	-696.08
3	5164.8	-348.85	86.332	2.0957	-181.08	-820.47
4	1926.0	-251.48	75.953	2.0957	-178.07	-620.89
5	3303.6	-249.14	68.704	2.0957	-155.64	-616.80
6	4681.3	-323.68	81.914	2.0957	-172.93	-764.10
7	1436.9	-267.11	82.973	2.0957	-192.14	-644.36
8	2820.0	-263.91	74.946	2.0957	-168.14	-638.67
9	4197.7	-328.87	85.548	2.0957	-179.63	-764.50
MINIMUM	1436.9	-348.85	68.704	2.0957	-195.97	-820.47
Pile N.	7	3	5	1	5	3
MAXIMUM	5164.8	-249.14	86.332	2.0957	-155.64	-616.80
Pile N.	3	5	3	1	5	5

THE PILE COORDINATE SYSTEM (LOCAL AXES)

* PILE TOP DISPLACEMENTS *

PILE GROUP	DISP. x, M	DISP. y, M	DISP. z, M	ROT. x,RAD	ROT. y,RAD	ROT. z,RAD
1	1.1229E-03	-1.5344E-03	4.7927E-04	5.9256E-06	5.2928E-05	1.5078E-04
2	1.8014E-03	-1.5344E-03	4.5261E-04	5.9256E-06	5.2928E-05	1.5078E-04
3	2.4800E-03	-1.5344E-03	4.2594E-04	5.9256E-06	5.2928E-05	1.5078E-04
4	8.8474E-04	-1.5077E-03	4.7927E-04	5.9256E-06	5.2928E-05	1.5078E-04
5	1.5633E-03	-1.5077E-03	4.5261E-04	5.9256E-06	5.2928E-05	1.5078E-04
6	2.2418E-03	-1.5077E-03	4.2594E-04	5.9256E-06	5.2928E-05	1.5078E-04
7	6.4657E-04	-1.4810E-03	4.7927E-04	5.9256E-06	5.2928E-05	1.5078E-04
8	1.3251E-03	-1.4810E-03	4.5261E-04	5.9256E-06	5.2928E-05	1.5078E-04
9	2.0036E-03	-1.4810E-03	4.2594E-04	5.9256E-06	5.2928E-05	1.5078E-04
MINIMUM	6.4657E-04	-1.5344E-03	4.2594E-04	5.9256E-06	5.2928E-05	1.5078E-04
Pile N.	7	1	3	1	1	1
MAXIMUM	2.4800E-03	-1.4810E-03	4.7927E-04	5.9256E-06	5.2928E-05	1.5078E-04
Pile N.	3	7	1	1	1	1

* PILE TOP REACTIONS *

PILE GROUP	AXIAL, KN	LAT. y, KN	LAT. z, KN	MOM x, KN- M	MOM y, KN- M	MOM z, KN- M
1	2409.5	-287.60	84.883	2.0957	-195.97	-701.80
2	3787.2	-284.36	76.746	2.0957	-171.75	-696.08
3	5164.8	-348.85	86.332	2.0957	-181.08	-820.47
4	1926.0	-251.48	75.953	2.0957	-178.07	-620.89
5	3303.6	-249.14	68.704	2.0957	-155.64	-616.80
6	4681.3	-323.68	81.914	2.0957	-172.93	-764.10
7	1436.9	-267.11	82.973	2.0957	-192.14	-644.36
8	2820.0	-263.91	74.946	2.0957	-168.14	-638.67
9	4197.7	-328.87	85.548	2.0957	-179.63	-764.50
MINIMUM	1436.9	-348.85	68.704	2.0957	-195.97	-820.47
Pile N.	7	3	5	1	5	3
MAXIMUM	5164.8	-249.14	86.332	2.0957	-155.64	-616.80
Pile N.	3	5	3	1	5	5

PILE GROUP	STRESS, KN/ M**2
1	3562.6
2	4306.9

APPALTATORE:

Consorzio

Soci



ITINERARIO NAPOLI – BARI

PROGETTAZIONE:

Mandatario

Mandanti



RADDOPPIO TRATTA APICE – ORSARA
I LOTTO FUNZIONALE APICE – HIRPINIA

PROGETTO ESECUTIVO

RELAZIONE DI CALCOLO FONDAZIONI PILE P1, P2, P21, P22, P23
E P24

COMMESSA IF28	LOTTO 01	CODIFICA E ZZ CL	DOCUMENTO VI0403 002	REV. B	FOGLIO 110 di 161
------------------	-------------	---------------------	-------------------------	-----------	-------------------------

3	5458.5
4	3039.3
5	3789.3
6	5013.5
7	2842.4
8	3589.0
9	4745.5

MINIMUM	2842.4
Pile N.	7
MAXIMUM	5458.5
Pile N.	3

* EFFECTS FOR LATERALLY LOADED PILE *

* MINIMUM VALUES AND LOCATIONS *

PILE	DISPL. y-DIR M	DISPL. z-DIR M	MOMENT z-DIR KN- M	MOMENT y-DIR KN- M	SHEAR y-DIR KN	SHEAR z-DIR KN	SOIL REACT y-DIR KN/ M	SOIL REACT z-DIR KN/ M	TOTAL STRESS KN/ M**2	FLEX. RIG. z-DIR KN- M**2	FLEX. RIG. y-DIR KN- M**2
*****	*****	*****	*****	*****	*****	*****	*****	*****	*****	*****	*****
1	-1.5344E-03	-1.5782E-05	-411.72	-195.97	-287.63	-27.480	-130.47	-7.7268	1363.5	7.8279E+06	7.8279E+06
x(M)	0.0000	10.500	5.7000	0.0000	0.0000	8.1000	4.2000	10.800	30.000	0.0000	0.0000
2	-1.5344E-03	-1.4928E-05	-409.07	-171.75	-284.41	-25.623	-128.92	-7.1652	2143.1	7.8279E+06	7.8279E+06
x(M)	0.0000	10.500	5.7000	0.0000	0.0000	8.1000	4.2000	10.800	30.000	0.0000	0.0000
3	-1.5344E-03	-1.2694E-05	-468.99	-181.08	-348.93	-30.005	-169.40	-8.3599	2922.7	7.8279E+06	7.8279E+06
x(M)	0.0000	9.9000	5.4000	0.0000	0.0000	7.5000	4.2000	10.200	30.000	0.0000	0.0000
4	-1.5077E-03	-1.6534E-05	-376.17	-178.07	-251.50	-24.283	-110.92	-6.7085	1089.9	7.8279E+06	7.8279E+06
x(M)	0.0000	10.800	5.7000	0.0000	0.0000	8.4000	4.2000	10.800	30.000	0.0000	0.0000
5	-1.5077E-03	-1.5631E-05	-374.18	-155.64	-249.18	-22.739	-109.90	-6.2445	1869.5	7.8279E+06	7.8279E+06
x(M)	0.0000	10.800	5.7000	0.0000	0.0000	8.1000	4.2000	10.800	30.000	0.0000	0.0000
6	-1.5077E-03	-1.3029E-05	-445.48	-172.93	-323.75	-28.394	-156.23	-7.8979	2649.1	7.8279E+06	7.8279E+06
x(M)	0.0000	9.9000	5.4000	0.0000	0.0000	7.8000	4.2000	10.200	30.000	0.0000	0.0000
7	-1.4810E-03	-1.5969E-05	-390.79	-192.14	-267.13	-26.737	-122.58	-7.4900	813.13	7.8279E+06	7.8279E+06
x(M)	0.0000	10.500	5.7000	0.0000	0.0000	8.1000	4.2000	10.800	30.000	0.0000	0.0000
8	-1.4810E-03	-1.5112E-05	-388.13	-168.14	-263.95	-24.923	-121.04	-6.9413	1595.8	7.8279E+06	7.8279E+06
x(M)	0.0000	10.500	5.7000	0.0000	0.0000	8.1000	4.2000	10.800	30.000	0.0000	0.0000
9	-1.4810E-03	-1.2798E-05	-449.26	-179.63	-328.93	-29.651	-162.24	-8.2530	2375.4	7.8279E+06	7.8279E+06
x(M)	0.0000	9.9000	5.4000	0.0000	0.0000	7.5000	4.2000	10.200	30.000	0.0000	0.0000
Min.	-1.5344E-03	-1.6534E-05	-468.99	-195.97	-348.93	-30.005	-169.40	-8.3599	813.13	7.8279E+06	7.8279E+06
Pile N.	1	4	3	1	3	3	3	3	7	1	1

* MAXIMUM VALUES AND LOCATIONS *

PILE	DISPL. y-DIR M	DISPL. z-DIR M	MOMENT z-DIR KN- M	MOMENT y-DIR KN- M	SHEAR y-DIR KN	SHEAR z-DIR KN	SOIL REACT y-DIR KN/ M	SOIL REACT z-DIR KN/ M	TOTAL STRESS KN/ M**2	FLEX. RIG. z-DIR KN- M**2	FLEX. RIG. y-DIR KN- M**2
*****	*****	*****	*****	*****	*****	*****	*****	*****	*****	*****	*****
1	5.0980E-05	4.7927E-04	701.80	127.92	88.433	84.892	25.059	39.309	3562.6	7.8279E+06	7.8279E+06
x(M)	10.500	0.0000	5.4000	0.0000	8.1000	0.0000	10.800	4.2000	0.0000	0.0000	0.0000
2	5.1265E-05	4.5261E-04	696.08	119.93	87.501	76.758	24.761	35.954	4306.9	7.8279E+06	7.8279E+06
x(M)	10.500	0.0000	0.0000	5.4000	8.1000	0.0000	10.800	4.2000	0.0000	0.0000	0.0000
3	4.6697E-05	4.2594E-04	820.47	128.47	109.52	86.350	31.025	43.544	5458.5	7.8279E+06	7.8279E+06
x(M)	9.9000	0.0000	0.0000	5.1000	7.8000	0.0000	10.200	4.2000	0.0000	0.0000	0.0000
4	5.2337E-05	4.7927E-04	620.89	119.29	76.718	75.959	21.235	34.165	3039.3	7.8279E+06	7.8279E+06
x(M)	10.800	0.0000	0.0000	5.7000	8.4000	0.0000	10.800	4.2000	0.0000	0.0000	0.0000
5	5.2563E-05	4.5261E-04	616.80	111.93	76.107	68.714	20.999	31.327	3789.3	7.8279E+06	7.8279E+06
x(M)	10.800	0.0000	0.0000	5.7000	8.4000	0.0000	10.800	4.2000	0.0000	0.0000	0.0000
6	4.6971E-05	4.2594E-04	764.10	124.59	101.84	81.930	28.803	41.054	5013.5	7.8279E+06	7.8279E+06
x(M)	10.200	0.0000	0.0000	5.4000	7.8000	0.0000	10.500	4.2000	0.0000	0.0000	0.0000
7	4.9613E-05	4.7927E-04	644.36	126.00	82.861	82.978	23.339	38.656	2842.4	7.8279E+06	7.8279E+06
x(M)	10.500	0.0000	0.0000	5.7000	8.1000	0.0000	10.800	4.2000	0.0000	0.0000	0.0000
8	4.9947E-05	4.5261E-04	638.67	118.04	81.921	74.955	23.033	35.331	3589.0	7.8279E+06	7.8279E+06
x(M)	10.800	0.0000	0.0000	5.4000	8.1000	0.0000	10.800	4.2000	0.0000	0.0000	0.0000
9	4.5267E-05	4.2594E-04	764.50	127.77	104.24	85.563	29.419	43.643	4745.5	7.8279E+06	7.8279E+06
x(M)	9.9000	0.0000	0.0000	5.1000	7.8000	0.0000	10.200	4.2000	0.0000	0.0000	0.0000
Max.	5.2563E-05	4.7927E-04	820.47	128.47	109.52	86.350	31.025	43.643	5458.5	7.8279E+06	7.8279E+06
Pile N.	5	1	3	3	3	3	3	9	3	1	1

***** SUMMARY FOR LOAD CASES AND COMBINATIONS *****

***** LOAD CASES RESULTS *****

LOAD CASE : 1

* TABLE L * COMPUTATION ON PILE CAP

* EQUIVALENT CONCENTRATED LOAD AT ORIGIN *

LOAD X, KN	LOAD Y, KN	LOAD Z, KN	MOM X, KN- M	MOM Y, KN- M	MOM Z, KN- M
32155.0	-1369.00	1090.00	3.00000	17150.0	14443.5

* DISPLACEMENT OF GROUPED PILE FOUNDATION AT ORIGIN *

APPALTATORE:

Consorzio

Soci



ITINERARIO NAPOLI – BARI

PROGETTAZIONE:

Mandataria

Mandanti



RADDOPPIO TRATTA APICE – ORSARA
I LOTTO FUNZIONALE APICE – HIRPINIA

PROGETTO ESECUTIVO

RELAZIONE DI CALCOLO FONDAZIONI PILE P1, P2, P21, P22, P23
E P24

COMMESSA	LOTTO	CODIFICA	DOCUMENTO	REV.	FOGLIO
IF28	01	E ZZ CL	VI0403 002	B	111 di 161

DISP X, M	DISP Y, M	DISP Z, M	ROT X,RAD	ROT Y,RAD	ROT Z,RAD
1.69584E-03	-7.60934E-04	6.73358E-04	2.06397E-07	7.92837E-05	7.21543E-05

* PILE TOP DISPLACEMENTS, GLOBAL *

	DISP. X, M	DISP. Y, M	DISP. Z, M	ROT. X,RAD	ROT. Y,RAD	ROT. Z,RAD
MINIMUM	1.0144E-03	-7.6186E-04	6.7243E-04	2.0640E-07	7.9284E-05	7.2154E-05
Pile N.	7	1	3	1	1	1
MAXIMUM	2.3773E-03	-7.6001E-04	6.7429E-04	2.0640E-07	7.9284E-05	7.2154E-05
Pile N.	3	7	1	1	1	1

* PILE TOP REACTIONS, GLOBAL *

	FOR. X, KN	FOR. Y, KN	FOR. Z, KN	MOM X, KN- M	MOM Y, KN- M	MOM Z, KN- M
MINIMUM	2189.1	-178.34	103.19	0.072995	-308.15	-424.00
Pile N.	7	3	5	1	3	3
MAXIMUM	4956.4	-130.57	142.47	0.072995	-232.54	-330.20
Pile N.	3	5	3	1	5	5

* PILE TOP DISPLACEMENTS, LOCAL *

	DISP. x, M	DISP. y, M	DISP. z, M	ROT. x,RAD	ROT. y,RAD	ROT. z,RAD
MINIMUM	1.0144E-03	-7.6186E-04	6.7243E-04	2.0640E-07	7.9284E-05	7.2154E-05
Pile N.	7	1	3	1	1	1
MAXIMUM	2.3773E-03	-7.6001E-04	6.7429E-04	2.0640E-07	7.9284E-05	7.2154E-05
Pile N.	3	7	1	1	1	1

* PILE TOP REACTIONS, LOCAL *

	AXIAL, KN	LAT. y, KN	LAT. z, KN	MOM x, KN- M	MOM y, KN- M	MOM z, KN- M
MINIMUM	2189.1	-178.34	103.19	0.072995	-308.15	-424.00
Pile N.	7	3	5	1	3	3
MAXIMUM	4956.4	-130.57	142.47	0.072995	-232.54	-330.20
Pile N.	3	5	3	1	5	5

* EFFECTS FOR LATERALLY LOADED PILE *

PILE	DISPL. y-DIR M	DISPL. z-DIR M	MOMENT z-DIR KN- M	MOMENT y-DIR KN- M	SHEAR y-DIR KN	SHEAR z-DIR KN	SOIL REACT y-DIR KN/ M	SOIL REACT z-DIR KN/ M	TOTAL STRESS KN/ M**2
Min.	-7.6186E-04	-2.3359E-05	-235.30	-308.15	-178.38	-47.906	-93.418	-13.345	1238.8
Pile N.	1	5	3	3	3	3	3	3	7
Max.	2.6744E-05	6.7429E-04	424.00	205.14	54.901	142.50	15.528	77.061	4386.7
Pile N.	5	1	3	3	3	3	3	3	3

LOAD CASE : 2

* TABLE L * COMPUTATION ON PILE CAP

* EQUIVALENT CONCENTRATED LOAD AT ORIGIN *

LOAD X, KN	LOAD Y, KN	LOAD Z, KN	MOM X, KN- M	MOM Y, KN- M	MOM Z, KN- M
24933.0	-338.000	821.000	0.00000	12766.5	4031.00

* DISPLACEMENT OF GROUPED PILE FOUNDATION AT ORIGIN *

DISP X, M	DISP Y, M	DISP Z, M	ROT X,RAD	ROT Y,RAD	ROT Z,RAD
1.30062E-03	-1.93873E-04	5.05757E-04	-8.92810E-07	5.91274E-05	1.96120E-05

* PILE TOP DISPLACEMENTS, GLOBAL *

	DISP. X, M	DISP. Y, M	DISP. Z, M	ROT. X,RAD	ROT. Y,RAD	ROT. Z,RAD
MINIMUM	9.4629E-04	-1.9789E-04	5.0174E-04	-8.9281E-07	5.9127E-05	1.9612E-05
Pile N.	7	7	1	1	1	1
MAXIMUM	1.6550E-03	-1.8986E-04	5.0977E-04	-8.9281E-07	5.9127E-05	1.9612E-05
Pile N.	3	1	3	1	1	1

* PILE TOP REACTIONS, GLOBAL *

	FOR. X, KN	FOR. Y, KN	FOR. Z, KN	MOM X, KN- M	MOM Y, KN- M	MOM Z, KN- M
MINIMUM	2050.9	-42.991	78.010	-0.3158	-237.93	-98.821
Pile N.	7	3	5	1	3	3
MAXIMUM	3489.8	-32.349	109.24	-0.3158	-176.40	-79.428
Pile N.	3	5	3	1	5	5

* PILE TOP DISPLACEMENTS, LOCAL *

	DISP. x, M	DISP. y, M	DISP. z, M	ROT. x,RAD	ROT. y,RAD	ROT. z,RAD
MINIMUM	9.4629E-04	-1.9789E-04	5.0174E-04	-8.9281E-07	5.9127E-05	1.9612E-05
Pile N.	7	7	1	1	1	1
MAXIMUM	1.6550E-03	-1.8986E-04	5.0977E-04	-8.9281E-07	5.9127E-05	1.9612E-05
Pile N.	3	1	3	1	1	1

* PILE TOP REACTIONS, LOCAL *

	AXIAL, KN	LAT. y, KN	LAT. z, KN	MOM x, KN- M	MOM y, KN- M	MOM z, KN- M
MINIMUM	2050.9	-42.991	78.010	-0.3158	-237.93	-98.821
Pile N.	7	3	5	1	3	3
MAXIMUM	3489.8	-32.349	109.24	-0.3158	-176.40	-79.428
Pile N.	3	5	3	1	5	5

APPALTATORE:

Consorzio

Soci



ITINERARIO NAPOLI – BARI

PROGETTAZIONE:

Mandataria

Mandanti



RADDOPPIO TRATTA APICE – ORSARA
I LOTTO FUNZIONALE APICE – HIRPINIA

PROGETTO ESECUTIVO

RELAZIONE DI CALCOLO FONDAZIONI PILE P1, P2, P21, P22, P23 E P24

COMMESSA IF28	LOTTO 01	CODIFICA E ZZ CL	DOCUMENTO VI0403 002	REV. B	FOGLIO 112 di 161
------------------	-------------	---------------------	-------------------------	-----------	-------------------------

Pile N. 3 5 3 1 5 5

* EFFECTS FOR LATERALLY LOADED PILE *

PILE	DISPL. y-DIR M	DISPL. z-DIR M	MOMENT z-DIR KN- M	MOMENT y-DIR KN- M	SHEAR y-DIR KN	SHEAR z-DIR KN	SOIL REACT y-DIR KN/ M	SOIL REACT z-DIR KN/ M	TOTAL STRESS KN/ M**2
Min.	-1.9789E-04	-1.7540E-05	-58.356	-237.93	-42.998	-36.305	-22.715	-10.130	1160.6
Pile N.	7	5	3	3	3	3	3	3	7
Max.	6.9000E-06	5.0977E-04	98.821	155.62	13.584	109.25	3.8283	58.757	2752.4
Pile N.	8	3	3	3	3	3	3	3	3

LOAD CASE : 3

* TABLE L * COMPUTATION ON PILE CAP

* EQUIVALENT CONCENTRATED LOAD AT ORIGIN *

LOAD X, KN	LOAD Y, KN	LOAD Z, KN	MOM X, KN- M	MOM Y, KN- M	MOM Z, KN- M
29211.0	-959.000	873.000	0.00000	18986.5	10268.5

* DISPLACEMENT OF GROUPED PILE FOUNDATION AT ORIGIN *

DISP X, M	DISP Y, M	DISP Z, M	ROT X,RAD	ROT Y,RAD	ROT Z,RAD
1.53473E-03	-5.34541E-04	6.01417E-04	-5.29576E-07	8.37799E-05	5.11199E-05

* PILE TOP DISPLACEMENTS, GLOBAL *

	DISP. X, M	DISP. Y, M	DISP. Z, M	ROT. X,RAD	ROT. Y,RAD	ROT. Z,RAD
MINIMUM	9.2768E-04	-5.3692E-04	5.9903E-04	-5.2958E-07	8.3780E-05	5.1120E-05
Pile N.	7	7	1	1	1	1
MAXIMUM	2.1418E-03	-5.3216E-04	6.0380E-04	-5.2958E-07	8.3780E-05	5.1120E-05
Pile N.	3	1	3	1	1	1

* PILE TOP REACTIONS, GLOBAL *

	FOR. X, KN	FOR. Y, KN	FOR. Z, KN	MOM X, KN- M	MOM Y, KN- M	MOM Z, KN- M
MINIMUM	2013.1	-124.03	81.883	-0.1873	-223.51	-293.23
Pile N.	7	3	5	1	3	3
MAXIMUM	4478.2	-91.468	116.03	-0.1873	-157.65	-230.36
Pile N.	3	5	3	1	5	5

* PILE TOP DISPLACEMENTS, LOCAL *

	DISP. x, M	DISP. y, M	DISP. z, M	ROT. x,RAD	ROT. y,RAD	ROT. z,RAD
MINIMUM	9.2768E-04	-5.3692E-04	5.9903E-04	-5.2958E-07	8.3780E-05	5.1120E-05
Pile N.	7	7	1	1	1	1
MAXIMUM	2.1418E-03	-5.3216E-04	6.0380E-04	-5.2958E-07	8.3780E-05	5.1120E-05
Pile N.	3	1	3	1	1	1

* PILE TOP REACTIONS, LOCAL *

	AXIAL, KN	LAT. y, KN	LAT. z, KN	MOM x, KN- M	MOM y, KN- M	MOM z, KN- M
MINIMUM	2013.1	-124.03	81.883	-0.1873	-223.51	-293.23
Pile N.	7	3	5	1	3	3
MAXIMUM	4478.2	-91.468	116.03	-0.1873	-157.65	-230.36
Pile N.	3	5	3	1	5	5

* EFFECTS FOR LATERALLY LOADED PILE *

PILE	DISPL. y-DIR M	DISPL. z-DIR M	MOMENT z-DIR KN- M	MOMENT y-DIR KN- M	SHEAR y-DIR KN	SHEAR z-DIR KN	SOIL REACT y-DIR KN/ M	SOIL REACT z-DIR KN/ M	TOTAL STRESS KN/ M**2
Min.	-5.3692E-04	-2.0609E-05	-164.23	-223.51	-124.05	-42.690	-64.998	-11.701	1139.2
Pile N.	7	5	3	3	3	3	3	3	7
Max.	1.8773E-05	6.0380E-04	293.23	183.62	38.299	116.05	10.826	64.842	3646.9
Pile N.	5	3	3	3	3	3	3	3	3

LOAD CASE : 4

* TABLE L * COMPUTATION ON PILE CAP

* EQUIVALENT CONCENTRATED LOAD AT ORIGIN *

LOAD X, KN	LOAD Y, KN	LOAD Z, KN	MOM X, KN- M	MOM Y, KN- M	MOM Z, KN- M
29727.0	-2605.00	718.000	248.000	11486.0	30953.5

* DISPLACEMENT OF GROUPED PILE FOUNDATION AT ORIGIN *

DISP X, M	DISP Y, M	DISP Z, M	ROT X,RAD	ROT Y,RAD	ROT Z,RAD
1.56326E-03	-1.50770E-03	4.52605E-04	5.92564E-06	5.29280E-05	1.50782E-04

* PILE TOP DISPLACEMENTS, GLOBAL *

	DISP. X, M	DISP. Y, M	DISP. Z, M	ROT. X,RAD	ROT. Y,RAD	ROT. Z,RAD
MINIMUM	6.4657E-04	-1.5344E-03	4.2594E-04	5.9256E-06	5.2928E-05	1.5078E-04
Pile N.	7	1	3	1	1	1
MAXIMUM	2.4800E-03	-1.4810E-03	4.7927E-04	5.9256E-06	5.2928E-05	1.5078E-04
Pile N.	3	7	1	1	1	1

APPALTATORE: Consorzio Soci   	ITINERARIO NAPOLI – BARI RADDOPPIO TRATTA APICE – ORSARA I LOTTO FUNZIONALE APICE – HIRPINIA
PROGETTAZIONE: Mandataria Mandanti   	
PROGETTO ESECUTIVO RELAZIONE DI CALCOLO FONDAZIONI PILE P1, P2, P21, P22, P23 E P24	COMMESSA IF28 LOTTO 01 CODIFICA E ZZ CL DOCUMENTO VI0403 002 REV. B FOGLIO 113 di 161

* PILE TOP REACTIONS, GLOBAL *

	FOR. X, KN	FOR. Y, KN	FOR. Z, KN	MOM X, KN- M	MOM Y, KN- M	MOM Z, KN- M
MINIMUM	1436.9	-348.85	68.704	2.0957	-195.97	-820.47
Pile N.	7	3	5	1	1	3
MAXIMUM	5164.8	-249.14	86.332	2.0957	-155.64	-616.80
Pile N.	3	5	3	1	5	5

* PILE TOP DISPLACEMENTS, LOCAL *

	DISP. x, M	DISP. y, M	DISP. z, M	ROT. x, RAD	ROT. y, RAD	ROT. z, RAD
MINIMUM	6.4657E-04	-1.5344E-03	4.2594E-04	5.9256E-06	5.2928E-05	1.5078E-04
Pile N.	7	1	3	1	1	1
MAXIMUM	2.4800E-03	-1.4810E-03	4.7927E-04	5.9256E-06	5.2928E-05	1.5078E-04
Pile N.	3	7	1	1	1	1

* PILE TOP REACTIONS, LOCAL *

	AXIAL, KN	LAT. y, KN	LAT. z, KN	MOM x, KN- M	MOM y, KN- M	MOM z, KN- M
MINIMUM	1436.9	-348.85	68.704	2.0957	-195.97	-820.47
Pile N.	7	3	5	1	1	3
MAXIMUM	5164.8	-249.14	86.332	2.0957	-155.64	-616.80
Pile N.	3	5	3	1	5	5

* EFFECTS FOR LATERALLY LOADED PILE *

PILE	DISPL. y-DIR M	DISPL. z-DIR M	MOMENT z-DIR KN- M	MOMENT y-DIR KN- M	SHEAR y-DIR KN	SHEAR z-DIR KN	SOIL REACT y-DIR KN/ M	SOIL REACT z-DIR KN/ M	TOTAL STRESS KN/ M**2
Min.	-1.5344E-03	-1.6534E-05	-468.99	-195.97	-348.93	-30.005	-169.40	-8.3599	813.13
Pile N.	1	4	3	1	3	3	3	3	7
Max.	5.2563E-05	4.7927E-04	820.47	128.47	109.52	86.350	31.025	43.643	5458.5
Pile N.	5	1	3	3	3	3	3	9	3

12.2 PILA SLU – SLV

GROUP for Windows, Version 2016.10.13

Serial Number : 228330872

Analysis of A Group of Piles
 Subjected to Axial and Lateral Loading

(c) Copyright ENSOFT, Inc., 1987-2015
 All Rights Reserved

Time and Date of Analysis

Date: July 07, 2020 Time: 18:33:34

***** COMPUTATION RESULTS *****

New Group

***** LOAD CASES RESULTS *****

LOAD CASE : 1
 CASE NAME : Load Case
 LOAD TYPE : Special, Sp

REDUCTION FACTORS FOR CLOSELY-SPACED PILE GROUPS, COMBINED Y AND Z DIRECTIONS
 ESTIMATED USING MOVEMENT IN THE DIRECTION OF PILE CAP DISPLACEMENTS

GROUP NO	P-FACTOR	Y-FACTOR
1	0.8506	1.0000
2	0.5741	1.0000

APPALTATORE: Consorzio Soci   	ITINERARIO NAPOLI – BARI RADDOPPIO TRATTA APICE – ORSARA I LOTTO FUNZIONALE APICE – HIRPINIA
PROGETTAZIONE: Mandataria Mandanti   	
PROGETTO ESECUTIVO RELAZIONE DI CALCOLO FONDAZIONI PILE P1, P2, P21, P22, P23 E P24	

3	0.5845	1.0000
4	0.7926	1.0000
5	0.4962	1.0000
6	0.5023	1.0000
7	0.8661	1.0000
8	0.5964	1.0000
9	0.6068	1.0000

* TABLE L * COMPUTATION ON PILE CAP

* EQUIVALENT CONCENTRATED LOAD AT ORIGIN *

VERT. LOAD, KN 23727.0	HOR. LOAD Y, KN 10828.4	HOR. LOAD Z, KN -2743.40
MOMENT X, KN- M -158.000	MOMENT Y, KN- M -30134.5	MOMENT Z, KN- M -1.08980E+05

* DISPLACEMENT OF GROUPED PILE FOUNDATION AT ORIGIN *

VERTICAL, M 1.34385E-03	HORIZONTAL Y, M 7.87064E-03	HORIZONTAL Z, M -2.07376E-03
ANGLE ROT. X, RAD 1.33807E-05	ANGLE ROT. Y, RAD -1.68150E-04	ANGLE ROT. Z, RAD -5.76500E-04

THE GLOBAL STRUCTURAL COORDINATE SYSTEM

* PILE TOP DISPLACEMENTS *

PILE GROUP	DISP. X, M	DISP. Y, M	DISP. Z, M	ROT. X, RAD	ROT. Y, RAD	ROT. Z, RAD
*****	*****	*****	*****	*****	*****	*****
1	3.1814E-03	7.8104E-03	-2.0135E-03	1.3381E-05	-1.6815E-04	-5.7650E-04
2	5.8718E-04	7.8104E-03	-2.0738E-03	1.3381E-05	-1.6815E-04	-5.7650E-04
3	-2.0071E-03	7.8104E-03	-2.1340E-03	1.3381E-05	-1.6815E-04	-5.7650E-04
4	3.9381E-03	7.8706E-03	-2.0135E-03	1.3381E-05	-1.6815E-04	-5.7650E-04
5	1.3438E-03	7.8706E-03	-2.0738E-03	1.3381E-05	-1.6815E-04	-5.7650E-04
6	-1.2504E-03	7.8706E-03	-2.1340E-03	1.3381E-05	-1.6815E-04	-5.7650E-04
7	4.6948E-03	7.9309E-03	-2.0135E-03	1.3381E-05	-1.6815E-04	-5.7650E-04
8	2.1005E-03	7.9309E-03	-2.0738E-03	1.3381E-05	-1.6815E-04	-5.7650E-04
9	-4.9372E-04	7.9309E-03	-2.1340E-03	1.3381E-05	-1.6815E-04	-5.7650E-04
MINIMUM	-2.0071E-03	7.8104E-03	-2.1340E-03	1.3381E-05	-1.6815E-04	-5.7650E-04
Pile N.	3	1	3	1	1	1
MAXIMUM	4.6948E-03	7.9309E-03	-2.0135E-03	1.3381E-05	-1.6815E-04	-5.7650E-04
Pile N.	7	7	1	1	1	1



* PILE TOP REACTIONS *



PILE GROUP	FOR. X, KN	FOR. Y, KN	FOR. Z, KN	MOM X, KN- M	MOM Y, KN- M	MOM Z, KN- M
*****	*****	*****	*****	*****	*****	*****
1	6589.1	1421.3	-351.35	4.7323	915.85	3839.6
2	1304.9	1107.0	-283.96	4.7323	781.44	3142.5
3	-4168.9	1123.8	-299.97	4.7323	827.84	3167.2
4	7707.4	1367.4	-334.33	4.7323	880.75	3744.3
5	2858.1	1013.0	-256.78	4.7323	720.32	2943.8
6	-2639.4	1025.0	-270.49	4.7323	761.59	2958.2
7	8765.7	1456.5	-352.92	4.7323	920.51	3951.3
8	4394.4	1148.8	-288.74	4.7323	794.27	3272.4
9	-1084.3	1165.6	-304.86	4.7323	840.93	3296.9
MINIMUM	-4168.9	1013.0	-352.92	4.7323	720.32	2943.8
Pile N.	3	5	7	1	5	5
MAXIMUM	8765.7	1456.5	-256.78	4.7323	920.51	3951.3
Pile N.	7	7	5	1	7	7

THE PILE COORDINATE SYSTEM (LOCAL AXES)

* PILE TOP DISPLACEMENTS *

PILE GROUP	DISP. x, M	DISP. y, M	DISP. z, M	ROT. x, RAD	ROT. y, RAD	ROT. z, RAD
*****	*****	*****	*****	*****	*****	*****
1	3.1814E-03	7.8104E-03	-2.0135E-03	1.3381E-05	-1.6815E-04	-5.7650E-04
2	5.8718E-04	7.8104E-03	-2.0738E-03	1.3381E-05	-1.6815E-04	-5.7650E-04
3	-2.0071E-03	7.8104E-03	-2.1340E-03	1.3381E-05	-1.6815E-04	-5.7650E-04
4	3.9381E-03	7.8706E-03	-2.0135E-03	1.3381E-05	-1.6815E-04	-5.7650E-04
5	1.3438E-03	7.8706E-03	-2.0738E-03	1.3381E-05	-1.6815E-04	-5.7650E-04
6	-1.2504E-03	7.8706E-03	-2.1340E-03	1.3381E-05	-1.6815E-04	-5.7650E-04

APPALDATORE:
Consorzio **Soci**
  

PROGETTAZIONE:
Mandataria **Mandanti**
  

PROGETTO ESECUTIVO
RELAZIONE DI CALCOLO FONDAZIONI PILE P1, P2, P21, P22, P23 E P24

ITINERARIO NAPOLI – BARI
RADDOPPIO TRATTA APICE – ORSARA
I LOTTO FUNZIONALE APICE – HIRPINIA

COMMESSA IF28	LOTTO 01	CODIFICA E ZZ CL	DOCUMENTO VI0403 002	REV. B	FOGLIO 115 di 161
-------------------------	--------------------	----------------------------	--------------------------------	------------------	--------------------------------

	7	4.6948E-03	7.9309E-03	-2.0135E-03	1.3381E-05	-1.6815E-04	-5.7650E-04
	8	2.1005E-03	7.9309E-03	-2.0738E-03	1.3381E-05	-1.6815E-04	-5.7650E-04
	9	-4.9372E-04	7.9309E-03	-2.1340E-03	1.3381E-05	-1.6815E-04	-5.7650E-04
MINIMUM		-2.0071E-03	7.8104E-03	-2.1340E-03	1.3381E-05	-1.6815E-04	-5.7650E-04
Pile N.		3	1	3	1	1	1
MAXIMUM		4.6948E-03	7.9309E-03	-2.0135E-03	1.3381E-05	-1.6815E-04	-5.7650E-04
Pile N.		7	7	1	1	1	1

*** PILE TOP REACTIONS ***

PILE GROUP	AXIAL, KN	LAT. y, KN	LAT. z, KN	MOM x, KN- M	MOM y, KN- M	MOM z, KN- M
*****	*****	*****	*****	*****	*****	*****
1	6589.1	1421.3	-351.35	4.7323	915.85	3839.6
2	1304.9	1107.0	-283.96	4.7323	781.44	3142.5
3	-4168.9	1123.8	-299.97	4.7323	827.84	3167.2
4	7707.4	1367.4	-334.33	4.7323	880.75	3744.3
5	2858.1	1013.0	-256.78	4.7323	720.32	2943.8
6	-2639.4	1025.0	-270.49	4.7323	761.59	2958.2
7	8765.7	1456.5	-352.92	4.7323	920.51	3951.3
8	4394.4	1148.8	-288.74	4.7323	794.27	3272.4
9	-1084.3	1165.6	-304.86	4.7323	840.93	3296.9
MINIMUM	-4168.9	1013.0	-352.92	4.7323	720.32	2943.8
Pile N.	3	5	7	1	5	5
MAXIMUM	8765.7	1456.5	-256.78	4.7323	920.51	3951.3
Pile N.	7	7	5	1	7	7

PILE GROUP	STRESS, KN/ M**2
*****	*****
1	1.5642E+04
2	1.0512E+04
3	1.2239E+04
4	1.5970E+04
5	1.0764E+04
6	1.0713E+04
7	1.7205E+04
8	1.2650E+04
9	1.0882E+04
MINIMUM	1.0512E+04
Pile N.	2
MAXIMUM	1.7205E+04
Pile N.	7

*** EFFECTS FOR LATERALLY LOADED PILE ***

*** MINIMUM VALUES AND LOCATIONS ***

PILE	DISPL. y-DIR	DISPL. z-DIR	MOMENT z-DIR	MOMENT y-DIR	SHEAR y-DIR	SHEAR z-DIR	SOIL REACT y-DIR	SOIL REACT z-DIR	TOTAL STRESS	FLEX. RIG. z-DIR	FLEX. RIG. y-DIR
*****	*****	*****	*****	*****	*****	*****	*****	*****	*****	*****	*****
1	-1.8831E-04	-2.0135E-03	-3839.6	-474.79	-426.32	-351.47	-101.18	-110.57	3728.7	7.8279E+06	7.8279E+06
x(M)	11.100	0.0000	0.0000	6.3000	9.0000	0.0000	10.800	4.2000	30.000	0.0000	0.0000
2	-1.8509E-04	-2.0738E-03	-3142.5	-412.05	-324.24	-283.98	-65.601	-81.184	738.44	7.8279E+06	7.8279E+06
x(M)	11.700	0.0000	0.0000	6.6000	9.6000	0.0000	16.200	4.2000	30.000	0.0000	0.0000
3	-1.8404E-04	-2.1340E-03	-3167.2	-426.84	-326.10	-299.90	-65.697	-85.399	2359.1	7.8279E+06	7.8279E+06
x(M)	11.700	0.0000	0.0000	6.6000	9.6000	0.0000	16.200	4.2000	30.000	0.0000	0.0000
4	-1.9057E-04	-2.0135E-03	-3744.3	-460.02	-410.62	-334.46	-93.645	-103.58	4361.5	7.8279E+06	7.8279E+06
x(M)	11.100	0.0000	0.0000	6.3000	9.0000	0.0000	10.800	4.2000	30.000	0.0000	0.0000
5	-1.8326E-04	-2.0738E-03	-2943.8	-386.34	-296.06	-256.82	-64.854	-71.014	1617.4	7.8279E+06	7.8279E+06
x(M)	12.000	0.0000	0.0000	6.9000	9.9000	0.0000	16.200	4.2000	30.000	0.0000	0.0000
6	-1.8202E-04	-2.1340E-03	-2958.2	-399.18	-296.49	-270.45	-64.962	-74.342	1493.6	7.8279E+06	7.8279E+06
x(M)	12.000	0.0000	0.0000	6.9000	9.9000	0.0000	16.200	4.2000	30.000	0.0000	0.0000
7	-1.9106E-04	-2.0135E-03	-3951.3	-476.92	-436.88	-353.07	-103.97	-111.45	4960.4	7.8279E+06	7.8279E+06
x(M)	11.100	0.0000	0.0000	6.3000	9.0000	0.0000	10.800	4.2000	30.000	0.0000	0.0000
8	-1.8920E-04	-2.0738E-03	-3272.4	-417.90	-337.50	-288.81	-66.722	-83.315	2486.7	7.8279E+06	7.8279E+06
x(M)	11.700	0.0000	0.0000	6.6000	9.6000	0.0000	16.200	4.2000	30.000	0.0000	0.0000
9	-1.8807E-04	-2.1340E-03	-3296.9	-432.80	-339.27	-304.84	-66.721	-87.584	613.60	7.8279E+06	7.8279E+06
x(M)	11.700	0.0000	0.0000	6.6000	9.6000	0.0000	16.200	4.2000	30.000	0.0000	0.0000
Min.	-1.9106E-04	-2.1340E-03	-3951.3	-476.92	-436.88	-353.07	-103.97	-111.45	613.60	7.8279E+06	7.8279E+06
Pile N.	7	3	7	7	7	7	7	7	9	1	1

*** MAXIMUM VALUES AND LOCATIONS ***

PILE	DISPL. y-DIR	DISPL. z-DIR	MOMENT z-DIR	MOMENT y-DIR	SHEAR y-DIR	SHEAR z-DIR	SOIL REACT y-DIR	SOIL REACT z-DIR	TOTAL STRESS	FLEX. RIG. z-DIR	FLEX. RIG. y-DIR
*****	*****	*****	*****	*****	*****	*****	*****	*****	*****	*****	*****
1	7.8104E-03	4.7714E-05	1855.4	915.85	1421.8	108.31	440.59	25.718	1.5642E+04	7.8279E+06	7.8279E+06
x(M)	0.0000	11.100	6.3000	0.0000	8.7000	0.0000	10.800	0.0000	4.2000	0.0000	0.0000
2	7.8104E-03	4.8668E-05	1557.7	781.44	1107.1	85.117	312.19	16.905	1.0512E+04	7.8279E+06	7.8279E+06
x(M)	0.0000	11.700	6.6000	0.0000	9.6000	0.0000	16.200	0.0000	4.2000	0.0000	0.0000
3	7.8104E-03	4.9938E-05	1566.5	827.84	1123.6	88.392	317.03	17.586	1.2239E+04	7.8279E+06	7.8279E+06
x(M)	0.0000	11.700	6.6000	0.0000	9.6000	0.0000	16.200	0.0000	4.2000	0.0000	0.0000
4	7.8706E-03	4.7953E-05	1810.3	880.75	1367.9	103.53	416.66	23.653	1.5970E+04	7.8279E+06	7.8279E+06

APPALTATORE: Consorzio Soci   	ITINERARIO NAPOLI – BARI RADDOPPIO TRATTA APICE – ORSARA I LOTTO FUNZIONALE APICE – HIRPINIA
PROGETTAZIONE: Mandataria Mandanti   	
PROGETTO ESECUTIVO RELAZIONE DI CALCOLO FONDAZIONI PILE P1, P2, P21, P22, P23 E P24	
	COMMESSA IF28 LOTTO 01 CODIFICA E ZZ CL DOCUMENTO VI0403 002 REV. B FOGLIO 116 di 161

x(M)	0.0000	11.100	6.3000	0.0000	0.0000	9.0000	4.2000	10.800	0.0000	0.0000	0.0000
5	7.8706E-03	4.7827E-05	1473.8	720.32	1013.2	76.985	275.71	16.569	1.0764E+04	7.8279E+06	7.8279E+06
x(M)	0.0000	12.000	6.9000	0.0000	0.0000	9.9000	4.2000	16.200	0.0000	0.0000	0.0000
6	7.8706E-03	4.9011E-05	1477.7	761.59	1024.8	79.638	278.61	17.234	1.0713E+04	7.8279E+06	7.8279E+06
x(M)	0.0000	12.000	6.9000	0.0000	0.0000	9.9000	4.2000	16.200	0.0000	0.0000	0.0000
7	7.9309E-03	4.7568E-05	1894.4	920.51	1457.1	109.36	452.35	25.973	1.7205E+04	7.8279E+06	7.8279E+06
x(M)	0.0000	11.100	6.3000	0.0000	0.0000	8.7000	4.2000	10.800	0.0000	0.0000	0.0000
8	7.9309E-03	4.8867E-05	1605.9	794.27	1149.1	87.010	326.34	16.847	1.2650E+04	7.8279E+06	7.8279E+06
x(M)	0.0000	11.700	6.6000	0.0000	0.0000	9.6000	4.2000	16.200	0.0000	0.0000	0.0000
9	7.9309E-03	5.0141E-05	1614.4	840.93	1165.5	90.337	331.18	17.503	1.0882E+04	7.8279E+06	7.8279E+06
x(M)	0.0000	11.700	6.6000	0.0000	0.0000	9.6000	4.2000	16.200	0.0000	0.0000	0.0000
Max. Pile N.	7.9309E-03	5.0141E-05	1894.4	920.51	1457.1	109.36	452.35	25.973	1.7205E+04	7.8279E+06	7.8279E+06
	7	9	7	7	7	7	7	7	7	1	1

LOAD CASE : 2
CASE NAME : Load Case
LOAD TYPE : Special, Sp

REDUCTION FACTORS FOR CLOSELY-SPACED PILE GROUPS, COMBINED Y AND Z DIRECTIONS
ESTIMATED USING MOVEMENT IN THE DIRECTION OF PILE CAP DISPLACEMENTS

GROUP NO	P-FACTOR	Y-FACTOR
1	0.6092	1.0000
2	0.5982	1.0000
3	0.8661	1.0000
4	0.5030	1.0000
5	0.4962	1.0000
6	0.7912	1.0000
7	0.5845	1.0000
8	0.5735	1.0000
9	0.8489	1.0000

* TABLE L * COMPUTATION ON PILE CAP

* EQUIVALENT CONCENTRATED LOAD AT ORIGIN *

VERT. LOAD, KN	HOR. LOAD Y, KN	HOR. LOAD Z, KN
29884.0	-10137.6	2693.90
MOMENT X, KN- M	MOMENT Y, KN- M	MOMENT Z, KN- M
109.000	30734.5	1.00646E+05

* DISPLACEMENT OF GROUPED PILE FOUNDATION AT ORIGIN *

VERTICAL, M	HORIZONTAL Y, M	HORIZONTAL Z, M
1.69145E-03	-7.21107E-03	2.00934E-03
ANGLE ROT. X, RAD	ANGLE ROT. Y, RAD	ANGLE ROT. Z, RAD
1.77499E-05	1.69349E-04	5.40137E-04

THE GLOBAL STRUCTURAL COORDINATE SYSTEM

* PILE TOP DISPLACEMENTS *

PILE GROUP	DISP. X, M	DISP. Y, M	DISP. Z, M	ROT. X, RAD	ROT. Y, RAD	ROT. Z, RAD
1	2.2909E-05	-7.2909E-03	2.0892E-03	1.7750E-05	1.6935E-04	5.4014E-04
2	2.4535E-03	-7.2909E-03	2.0093E-03	1.7750E-05	1.6935E-04	5.4014E-04
3	4.8841E-03	-7.2909E-03	1.9295E-03	1.7750E-05	1.6935E-04	5.4014E-04
4	-7.3916E-04	-7.2111E-03	2.0892E-03	1.7750E-05	1.6935E-04	5.4014E-04
5	1.6914E-03	-7.2111E-03	2.0093E-03	1.7750E-05	1.6935E-04	5.4014E-04
6	4.1221E-03	-7.2111E-03	1.9295E-03	1.7750E-05	1.6935E-04	5.4014E-04
7	-1.5012E-03	-7.1312E-03	2.0892E-03	1.7750E-05	1.6935E-04	5.4014E-04
8	9.2938E-04	-7.1312E-03	2.0093E-03	1.7750E-05	1.6935E-04	5.4014E-04
9	3.3600E-03	-7.1312E-03	1.9295E-03	1.7750E-05	1.6935E-04	5.4014E-04
MINIMUM Pile N.	-1.5012E-03	-7.2909E-03	1.9295E-03	1.7750E-05	1.6935E-04	5.4014E-04
	7	1	3	1	1	1
MAXIMUM Pile N.	4.8841E-03	-7.1312E-03	2.0892E-03	1.7750E-05	1.6935E-04	5.4014E-04
	3	7	1	1	1	1

* PILE TOP REACTIONS *

PILE GROUP	FOR. X, KN	FOR. Y, KN	FOR. Z, KN	MOM X, KN- M	MOM Y, KN- M	MOM Z, KN- M
1	50.913	-1097.0	304.35	6.2775	-827.15	-3068.5

APPALTATORE:

Consorzio

Soci



ITINERARIO NAPOLI – BARI

PROGETTAZIONE:

Mandataria

Mandanti



RADDOPPIO TRATTA APICE – ORSARA
I LOTTO FUNZIONALE APICE – HIRPINIA

PROGETTO ESECUTIVO

RELAZIONE DI CALCOLO FONDAZIONI PILE P1, P2, P21, P22, P23
E P24

COMMESSA	LOTTO	CODIFICA	DOCUMENTO	REV.	FOGLIO
IF28	01	E ZZ CL	VI0403 002	B	117 di 161

2	5111.2	-1081.4	284.06	6.2775	-766.29	-3045.2
3	9030.5	-1368.4	341.35	6.2775	-870.32	-3670.6
4	-1606.1	-959.59	269.82	6.2775	-748.21	-2735.5
5	3563.9	-948.27	252.28	6.2775	-693.52	-2721.1
6	7964.7	-1279.0	323.32	6.2775	-832.24	-3459.7
7	-3146.5	-1047.6	299.39	6.2775	-814.11	-2913.7
8	2016.6	-1032.0	279.23	6.2775	-753.61	-2890.2
9	6898.8	-1324.3	340.10	6.2775	-866.51	-3530.5
MINIMUM	-3146.5	-1368.4	252.28	6.2775	-870.32	-3670.6
Pile N.	7	3	5	1	3	3
MAXIMUM	9030.5	-948.27	341.35	6.2775	-693.52	-2721.1
Pile N.	3	5	3	1	5	5

THE PILE COORDINATE SYSTEM (LOCAL AXES)

* PILE TOP DISPLACEMENTS *

PILE GROUP	DISP. x, M	DISP. y, M	DISP. z, M	ROT. x, RAD	ROT. y, RAD	ROT. z, RAD
1	2.2909E-05	-7.2909E-03	2.0892E-03	1.7750E-05	1.6935E-04	5.4014E-04
2	2.4535E-03	-7.2909E-03	2.0893E-03	1.7750E-05	1.6935E-04	5.4014E-04
3	4.8841E-03	-7.2909E-03	1.9295E-03	1.7750E-05	1.6935E-04	5.4014E-04
4	-7.3916E-04	-7.2111E-03	2.0892E-03	1.7750E-05	1.6935E-04	5.4014E-04
5	1.6914E-03	-7.2111E-03	2.0893E-03	1.7750E-05	1.6935E-04	5.4014E-04
6	4.1221E-03	-7.2111E-03	1.9295E-03	1.7750E-05	1.6935E-04	5.4014E-04
7	-1.5012E-03	-7.1312E-03	2.0892E-03	1.7750E-05	1.6935E-04	5.4014E-04
8	9.2938E-04	-7.1312E-03	2.0893E-03	1.7750E-05	1.6935E-04	5.4014E-04
9	3.3600E-03	-7.1312E-03	1.9295E-03	1.7750E-05	1.6935E-04	5.4014E-04
MINIMUM	-1.5012E-03	-7.2909E-03	1.9295E-03	1.7750E-05	1.6935E-04	5.4014E-04
Pile N.	7	1	3	1	1	1
MAXIMUM	4.8841E-03	-7.1312E-03	2.0892E-03	1.7750E-05	1.6935E-04	5.4014E-04
Pile N.	3	7	1	1	1	1

* PILE TOP REACTIONS *

PILE GROUP	AXIAL, KN	LAT. y, KN	LAT. z, KN	MOM x, KN- M	MOM y, KN- M	MOM z, KN- M
1	50.913	-1097.0	304.35	6.2775	-827.15	-3068.5
2	5111.2	-1081.4	284.06	6.2775	-766.29	-3045.2
3	9030.5	-1368.4	341.35	6.2775	-870.32	-3670.6
4	-1606.1	-959.59	269.82	6.2775	-748.21	-2735.5
5	3563.9	-948.27	252.28	6.2775	-693.52	-2721.1
6	7964.7	-1279.0	323.32	6.2775	-832.24	-3459.7
7	-3146.5	-1047.6	299.39	6.2775	-814.11	-2913.7
8	2016.6	-1032.0	279.23	6.2775	-753.61	-2890.2
9	6898.8	-1324.3	340.10	6.2775	-866.51	-3530.5
MINIMUM	-3146.5	-1368.4	252.28	6.2775	-870.32	-3670.6
Pile N.	7	3	5	1	3	3
MAXIMUM	9030.5	-948.27	341.35	6.2775	-693.52	-2721.1
Pile N.	3	5	3	1	5	5

PILE GROUP STRESS, KN/ M**2

1	9620.2
2	1.2369E+04
3	1.6495E+04
4	9468.0
5	1.0492E+04
6	1.5246E+04
7	1.0911E+04
8	1.0156E+04
9	1.4875E+04
MINIMUM	9468.0
Pile N.	4
MAXIMUM	1.6495E+04
Pile N.	3

* EFFECTS FOR LATERALLY LOADED PILE *

* MINIMUM VALUES AND LOCATIONS *

PILE	DISPL. y-DIR	DISPL. z-DIR	MOMENT z-DIR	MOMENT y-DIR	SHEAR y-DIR	SHEAR z-DIR	SOIL REACT y-DIR	SOIL REACT z-DIR	TOTAL STRESS	FLEX. RIG. z-DIR	FLEX. RIG. y-DIR
	M	M	KN- M	KN- M	KN	KN	KN/ M	KN/ M	KN/ M**2	KN- M**2	KN- M**2
x(M)	-7.2909E-03	-5.0131E-05	-1513.8	-827.15	-1097.0	-91.256	-315.68	-18.316	28.811	7.8279E+06	7.8279E+06
	0.0000	11.700	6.0000	0.0000	0.0000	9.3000	4.2000	10.800	30.000	0.0000	0.0000
2	-7.2909E-03	-4.8327E-05	-1505.7	-766.29	-1081.7	-86.881	-311.01	-17.315	2892.3	7.8279E+06	7.8279E+06
x(M)	0.0000	11.700	6.0000	0.0000	0.0000	9.3000	4.2000	10.800	30.000	0.0000	0.0000
3	-7.2909E-03	-4.5908E-05	-1770.9	-870.32	-1369.0	-107.84	-429.84	-26.112	5110.2	7.8279E+06	7.8279E+06
x(M)	0.0000	10.800	6.3000	0.0000	0.0000	8.7000	4.2000	10.800	30.000	0.0000	0.0000
4	-7.2111E-03	-4.9321E-05	-1379.1	-748.21	-959.51	-79.955	-264.36	-17.225	908.88	7.8279E+06	7.8279E+06

APPALTATORE: Consorzio HirpiniaAV Soci salini impregilo ASTALDI	ITINERARIO NAPOLI – BARI RADDOPPIO TRATTA APICE – ORSARA I LOTTO FUNZIONALE APICE – HIRPINIA					
PROGETTAZIONE: Mandatario ROK SOIL Mandanti NET ENGINEERING Alpina						
PROGETTO ESECUTIVO RELAZIONE DI CALCOLO FONDAZIONI PILE P1, P2, P21, P22, P23 E P24						
	COMMESSA IF28	LOTTO 01	CODIFICA E ZZ CL	DOCUMENTO VI0403 002	REV. B	FOGLIO 118 di 161

x(M)	0.0000	12.000	6.9000	0.0000	0.0000	9.6000	4.2000	16.200	30.000	0.0000	0.0000
5	-7.2111E-03	-4.7570E-05	-1375.0	-693.52	-948.45	-76.418	-261.47	-16.341	2016.7	7.8279E+06	7.8279E+06
x(M)	0.0000	12.000	6.9000	0.0000	0.0000	9.6000	4.2000	16.200	30.000	0.0000	0.0000
6	-7.2111E-03	-4.6324E-05	-1688.0	-832.24	-1279.6	-100.95	-394.46	-23.847	4507.1	7.8279E+06	7.8279E+06
x(M)	0.0000	11.100	6.3000	0.0000	0.0000	9.0000	4.2000	10.800	30.000	0.0000	0.0000
7	-7.1312E-03	-5.0240E-05	-1458.9	-814.11	-1047.5	-88.915	-299.63	-17.548	1780.5	7.8279E+06	7.8279E+06
x(M)	0.0000	11.700	6.6000	0.0000	0.0000	9.3000	4.2000	10.800	30.000	0.0000	0.0000
8	-7.1312E-03	-4.8394E-05	-1450.5	-753.61	-1032.1	-84.519	-294.99	-16.648	1141.2	7.8279E+06	7.8279E+06
x(M)	0.0000	11.700	6.6000	0.0000	0.0000	9.3000	4.2000	16.200	30.000	0.0000	0.0000
9	-7.1312E-03	-4.6095E-05	-1723.4	-866.51	-1324.8	-107.07	-415.87	-25.941	3903.9	7.8279E+06	7.8279E+06
x(M)	0.0000	10.800	6.3000	0.0000	0.0000	8.7000	4.2000	10.800	30.000	0.0000	0.0000
Min.	-7.2909E-03	-5.0240E-05	-1770.9	-870.32	-1369.0	-107.84	-429.84	-26.112	28.811	7.8279E+06	7.8279E+06
Pile N.	1	7	3	3	3	3	3	3	1	1	1

* MAXIMUM VALUES AND LOCATIONS *

PILE	DISPL. y-DIR M	DISPL. z-DIR M	MOMENT z-DIR KN- M	MOMENT y-DIR KN- M	SHEAR y-DIR KN	SHEAR z-DIR KN	SOIL REACT y-DIR KN/ M	SOIL REACT z-DIR KN/ M	TOTAL STRESS KN/ M**2	FLEX. RIG. z-DIR KN- M**2	FLEX. RIG. y-DIR KN- M**2
*****	*****	*****	*****	*****	*****	*****	*****	*****	*****	*****	*****
1	1.7697E-04	2.0892E-03	3068.5	431.75	321.24	304.35	64.027	88.687	9620.2	7.8279E+06	7.8279E+06
x(M)	11.700	0.0000	0.0000	6.6000	9.3000	0.0000	10.800	4.2000	0.0000	0.0000	0.0000
2	1.7828E-04	2.0093E-03	3045.2	412.23	319.16	284.14	62.946	83.252	1.2369E+04	7.8279E+06	7.8279E+06
x(M)	11.700	0.0000	0.0000	6.6000	9.3000	0.0000	10.800	4.2000	0.0000	0.0000	0.0000
3	1.7742E-04	1.9295E-03	3670.6	464.29	414.08	341.50	100.91	109.50	1.6495E+04	7.8279E+06	7.8279E+06
x(M)	10.800	0.0000	0.0000	6.0000	8.7000	0.0000	10.800	4.2000	0.0000	0.0000	0.0000
4	1.7172E-04	2.0892E-03	2735.5	397.72	277.99	269.80	60.921	75.244	9468.0	7.8279E+06	7.8279E+06
x(M)	12.000	0.0000	0.0000	6.9000	9.6000	0.0000	16.200	4.2000	0.0000	0.0000	0.0000
5	1.7296E-04	2.0093E-03	2721.1	380.52	277.27	252.32	60.876	70.899	1.0492E+04	7.8279E+06	7.8279E+06
x(M)	12.000	0.0000	0.0000	6.9000	9.9000	0.0000	16.200	4.2000	0.0000	0.0000	0.0000
6	1.7698E-04	1.9295E-03	3459.7	447.50	384.88	323.45	90.704	101.80	1.5246E+04	7.8279E+06	7.8279E+06
x(M)	11.100	0.0000	0.0000	6.3000	9.0000	0.0000	10.800	4.2000	0.0000	0.0000	0.0000
7	1.7293E-04	2.0892E-03	2913.7	425.98	305.36	299.34	61.200	86.464	1.0911E+04	7.8279E+06	7.8279E+06
x(M)	11.700	0.0000	0.0000	6.6000	9.6000	0.0000	16.200	4.2000	0.0000	0.0000	0.0000
8	1.7403E-04	2.0093E-03	2890.2	406.63	303.55	279.26	61.226	81.108	1.0156E+04	7.8279E+06	7.8279E+06
x(M)	11.700	0.0000	0.0000	6.6000	9.6000	0.0000	16.200	4.2000	0.0000	0.0000	0.0000
9	1.7371E-04	1.9295E-03	3530.5	462.47	401.21	340.21	97.763	108.81	1.4875E+04	7.8279E+06	7.8279E+06
x(M)	10.800	0.0000	0.0000	6.0000	8.7000	0.0000	10.800	4.2000	0.0000	0.0000	0.0000
Max.	1.7828E-04	2.0892E-03	3670.6	464.29	414.08	341.50	100.91	109.50	1.6495E+04	7.8279E+06	7.8279E+06
Pile N.	2	1	3	3	3	3	3	3	3	1	1

LOAD CASE : 3
CASE NAME : Load Case
LOAD TYPE : Special, Sp

REDUCTION FACTORS FOR CLOSELY-SPACED PILE GROUPS, COMBINED Y AND Z DIRECTIONS
ESTIMATED USING MOVEMENT IN THE DIRECTION OF PILE CAP DISPLACEMENTS

GROUP NO	P-FACTOR	Y-FACTOR
1	0.6248	1.0000
2	0.5071	1.0000
3	0.5845	1.0000
4	0.6105	1.0000
5	0.4962	1.0000
6	0.5699	1.0000
7	0.8661	1.0000
8	0.7817	1.0000
9	0.8374	1.0000

* TABLE L * COMPUTATION ON PILE CAP

* EQUIVALENT CONCENTRATED LOAD AT ORIGIN *

VERT. LOAD, KN 24213.0	HOR. LOAD Y, KN 3367.10	HOR. LOAD Z, KN -9111.30
MOMENT X, KN- M -363.000	MOMENT Y, KN- M -1.00998E+05	MOMENT Z, KN- M -33681.4

* DISPLACEMENT OF GROUPED PILE FOUNDATION AT ORIGIN *

VERTICAL, M 1.35285E-03	HORIZONTAL Y, M 2.36564E-03	HORIZONTAL Z, M -6.42540E-03
ANGLE ROT. X, RAD -2.24592E-05	ANGLE ROT. Y, RAD -5.16408E-04	ANGLE ROT. Z, RAD -1.85867E-04

APPALTATORE: Consorzio  Soci  		ITINERARIO NAPOLI – BARI RADDOPPIO TRATTA APICE – ORSARA I LOTTO FUNZIONALE APICE – HIRPINIA					
PROGETTAZIONE: Mandataria  Mandanti  							
PROGETTO ESECUTIVO RELAZIONE DI CALCOLO FONDAZIONI PILE P1, P2, P21, P22, P23 E P24							COMMESSA IF28

THE GLOBAL STRUCTURAL COORDINATE SYSTEM

* PILE TOP DISPLACEMENTS *

PILE GROUP	DISP. X, M	DISP. Y, M	DISP. Z, M	ROT. X,RAD	ROT. Y,RAD	ROT. Z,RAD
1	-1.3458E-04	2.4667E-03	-6.5265E-03	-2.2459E-05	-5.1641E-04	-1.8587E-04
2	-9.7098E-04	2.4667E-03	-6.4254E-03	-2.2459E-05	-5.1641E-04	-1.8587E-04
3	-1.8074E-03	2.4667E-03	-6.3243E-03	-2.2459E-05	-5.1641E-04	-1.8587E-04
4	2.1892E-03	2.3656E-03	-6.5265E-03	-2.2459E-05	-5.1641E-04	-1.8587E-04
5	1.3529E-03	2.3656E-03	-6.4254E-03	-2.2459E-05	-5.1641E-04	-1.8587E-04
6	5.1645E-04	2.3656E-03	-6.3243E-03	-2.2459E-05	-5.1641E-04	-1.8587E-04
7	4.5131E-03	2.2646E-03	-6.5265E-03	-2.2459E-05	-5.1641E-04	-1.8587E-04
8	3.6767E-03	2.2646E-03	-6.4254E-03	-2.2459E-05	-5.1641E-04	-1.8587E-04
9	2.8403E-03	2.2646E-03	-6.3243E-03	-2.2459E-05	-5.1641E-04	-1.8587E-04
MINIMUM	-1.8074E-03	2.2646E-03	-6.5265E-03	-2.2459E-05	-5.1641E-04	-1.8587E-04
Pile N.	3	7	1	1	1	1
MAXIMUM	4.5131E-03	2.4667E-03	-6.3243E-03	-2.2459E-05	-5.1641E-04	-1.8587E-04
Pile N.	7	1	3	1	1	1

* PILE TOP REACTIONS *

PILE GROUP	FOR. X, KN	FOR. Y, KN	FOR. Z, KN	MOM X, KN- M	MOM Y, KN- M	MOM Z, KN- M
1	-295.57	386.50	-1005.2	-7.9430	2729.2	1065.3
2	-2074.7	340.05	-864.75	-7.9430	2389.2	960.38
3	-3765.3	375.06	-934.03	-7.9430	2517.3	1037.7
4	4574.6	359.25	-988.59	-7.9430	2702.7	984.40
5	2876.4	315.98	-850.76	-7.9430	2367.5	886.42
6	1147.7	348.08	-917.18	-7.9430	2490.1	957.51
7	8511.6	423.65	-1236.4	-7.9430	3236.0	1097.0
8	7341.8	399.03	-1140.7	-7.9430	3008.0	1045.5
9	5896.4	419.50	-1173.7	-7.9430	3045.6	1086.9
MINIMUM	-3765.3	315.98	-1236.4	-7.9430	2367.5	886.42
Pile N.	3	5	7	1	5	5
MAXIMUM	8511.6	423.65	-850.76	-7.9430	3236.0	1097.0
Pile N.	7	7	5	1	7	7

THE PILE COORDINATE SYSTEM (LOCAL AXES)

* PILE TOP DISPLACEMENTS *

PILE GROUP	DISP. x, M	DISP. y, M	DISP. z, M	ROT. x,RAD	ROT. y,RAD	ROT. z,RAD
1	-1.3458E-04	2.4667E-03	-6.5265E-03	-2.2459E-05	-5.1641E-04	-1.8587E-04
2	-9.7098E-04	2.4667E-03	-6.4254E-03	-2.2459E-05	-5.1641E-04	-1.8587E-04
3	-1.8074E-03	2.4667E-03	-6.3243E-03	-2.2459E-05	-5.1641E-04	-1.8587E-04
4	2.1892E-03	2.3656E-03	-6.5265E-03	-2.2459E-05	-5.1641E-04	-1.8587E-04
5	1.3529E-03	2.3656E-03	-6.4254E-03	-2.2459E-05	-5.1641E-04	-1.8587E-04
6	5.1645E-04	2.3656E-03	-6.3243E-03	-2.2459E-05	-5.1641E-04	-1.8587E-04
7	4.5131E-03	2.2646E-03	-6.5265E-03	-2.2459E-05	-5.1641E-04	-1.8587E-04
8	3.6767E-03	2.2646E-03	-6.4254E-03	-2.2459E-05	-5.1641E-04	-1.8587E-04
9	2.8403E-03	2.2646E-03	-6.3243E-03	-2.2459E-05	-5.1641E-04	-1.8587E-04
MINIMUM	-1.8074E-03	2.2646E-03	-6.5265E-03	-2.2459E-05	-5.1641E-04	-1.8587E-04
Pile N.	3	7	1	1	1	1
MAXIMUM	4.5131E-03	2.4667E-03	-6.3243E-03	-2.2459E-05	-5.1641E-04	-1.8587E-04
Pile N.	7	1	3	1	1	1

* PILE TOP REACTIONS *

PILE GROUP	AXIAL, KN	LAT. y, KN	LAT. z, KN	MOM x, KN- M	MOM y, KN- M	MOM z, KN- M
1	-295.57	386.50	-1005.2	-7.9430	2729.2	1065.3
2	-2074.7	340.05	-864.75	-7.9430	2389.2	960.38
3	-3765.3	375.06	-934.03	-7.9430	2517.3	1037.7
4	4574.6	359.25	-988.59	-7.9430	2702.7	984.40
5	2876.4	315.98	-850.76	-7.9430	2367.5	886.42
6	1147.7	348.08	-917.18	-7.9430	2490.1	957.51
7	8511.6	423.65	-1236.4	-7.9430	3236.0	1097.0
8	7341.8	399.03	-1140.7	-7.9430	3008.0	1045.5
9	5896.4	419.50	-1173.7	-7.9430	3045.6	1086.9
MINIMUM	-3765.3	315.98	-1236.4	-7.9430	2367.5	886.42
Pile N.	3	5	7	1	5	5
MAXIMUM	8511.6	423.65	-850.76	-7.9430	3236.0	1097.0
Pile N.	7	7	5	1	7	7

PILE GROUP	STRESS, KN/ M**2
1	9009.2
2	8945.4

APPALTATORE:

Consorzio Soci

ITINERARIO NAPOLI - BARI

PROGETTAZIONE:

Mandataria Mandanti

RADDOPPIO TRATTA APICE - ORSARA
 I LOTTO FUNZIONALE APICE - HIRPINIA

PROGETTO ESECUTIVO

RELAZIONE DI CALCOLO FONDAZIONI PILE P1, P2, P21, P22, P23 E P24

COMMESSA IF28	LOTTO 01	CODIFICA E ZZ CL	DOCUMENTO VI0403 002	REV. B	FOGLIO 120 di 161
------------------	-------------	---------------------	-------------------------	-----------	-------------------------

3 1.0348E+04
 4 1.1270E+04
 5 9257.4
 6 8701.1
 7 1.5129E+04
 8 1.3766E+04
 9 1.3096E+04

MINIMUM 8701.1
 Pile N. 6
 MAXIMUM 1.5129E+04
 Pile N. 7

* EFFECTS FOR LATERALLY LOADED PILE *

* MINIMUM VALUES AND LOCATIONS *

PILE	DISPL. y-DIR M	DISPL. z-DIR M	MOMENT z-DIR KN- M	MOMENT y-DIR KN- M	SHEAR y-DIR KN	SHEAR z-DIR KN	SOIL REACT y-DIR KN/ M	SOIL REACT z-DIR KN/ M	TOTAL STRESS KN/ M**2	FLEX. RIG. z-DIR KN- M**2	FLEX. RIG. y-DIR KN- M**2
*****	*****	*****	*****	*****	*****	*****	*****	*****	*****	*****	*****
1	-6.1040E-05	-6.5265E-03	-1065.3	-1392.4	-113.70	-1005.2	-24.207	-296.98	167.26	7.8279E+06	7.8279E+06
x(M)	11.400	0.0000	0.0000	6.6000	9.3000	0.0000	10.800	4.2000	30.000	0.0000	0.0000
2	-6.0401E-05	-6.4254E-03	-960.38	-1254.8	-98.775	-864.65	-21.526	-244.10	1174.0	7.8279E+06	7.8279E+06
x(M)	12.000	0.0000	0.0000	6.6000	9.3000	0.0000	16.200	4.2000	30.000	0.0000	0.0000
3	-6.1266E-05	-6.3243E-03	-1037.7	-1317.5	-109.49	-933.85	-22.554	-273.49	2130.7	7.8279E+06	7.8279E+06
x(M)	11.700	0.0000	0.0000	6.6000	9.3000	0.0000	10.800	4.2000	30.000	0.0000	0.0000
4	-5.8646E-05	-6.5265E-03	-984.40	-1383.1	-107.58	-988.83	-22.670	-291.66	2588.7	7.8279E+06	7.8279E+06
x(M)	11.400	0.0000	0.0000	6.6000	9.3000	0.0000	10.800	4.2000	30.000	0.0000	0.0000
5	-5.8063E-05	-6.4254E-03	-886.42	-1246.7	-93.581	-850.89	-20.355	-239.98	1627.7	7.8279E+06	7.8279E+06
x(M)	12.000	0.0000	0.0000	6.6000	9.6000	0.0000	16.200	4.2000	30.000	0.0000	0.0000
6	-5.8943E-05	-6.3243E-03	-957.51	-1307.6	-103.48	-917.24	-21.070	-268.10	649.49	7.8279E+06	7.8279E+06
x(M)	11.700	0.0000	0.0000	6.6000	9.3000	0.0000	10.800	4.2000	30.000	0.0000	0.0000
7	-5.5122E-05	-6.5265E-03	-1097.0	-1612.5	-131.78	-1236.9	-32.845	-396.19	4816.6	7.8279E+06	7.8279E+06
x(M)	10.800	0.0000	0.0000	6.0000	8.7000	0.0000	10.800	4.2000	30.000	0.0000	0.0000
8	-5.5872E-05	-6.4254E-03	-1045.5	-1523.6	-122.98	-1141.1	-29.818	-358.48	4154.6	7.8279E+06	7.8279E+06
x(M)	11.100	0.0000	0.0000	6.3000	8.7000	0.0000	10.800	4.2000	30.000	0.0000	0.0000
9	-5.5519E-05	-6.3243E-03	-1086.9	-1547.7	-130.09	-1174.0	-32.370	-375.94	3336.7	7.8279E+06	7.8279E+06
x(M)	10.800	0.0000	0.0000	6.0000	8.7000	0.0000	10.800	4.2000	30.000	0.0000	0.0000
Min.	-6.1266E-05	-6.5265E-03	-1097.0	-1612.5	-131.78	-1236.9	-32.845	-396.19	167.26	7.8279E+06	7.8279E+06
Pile N.	3	1	7	7	7	7	7	7	1	1	1

* MAXIMUM VALUES AND LOCATIONS *

PILE	DISPL. y-DIR M	DISPL. z-DIR M	MOMENT z-DIR KN- M	MOMENT y-DIR KN- M	SHEAR y-DIR KN	SHEAR z-DIR KN	SOIL REACT y-DIR KN/ M	SOIL REACT z-DIR KN/ M	TOTAL STRESS KN/ M**2	FLEX. RIG. z-DIR KN- M**2	FLEX. RIG. y-DIR KN- M**2
*****	*****	*****	*****	*****	*****	*****	*****	*****	*****	*****	*****
1	2.4667E-03	1.6060E-04	527.82	2729.2	386.49	299.14	113.45	63.906	9009.2	7.8279E+06	7.8279E+06
x(M)	0.0000	11.400	6.6000	0.0000	0.0000	9.3000	4.2000	10.800	0.0000	0.0000	0.0000
2	2.4667E-03	1.5612E-04	483.28	2389.2	340.01	255.47	95.070	54.969	8945.4	7.8279E+06	7.8279E+06
x(M)	0.0000	12.000	6.9000	0.0000	0.0000	9.6000	4.2000	16.200	0.0000	0.0000	0.0000
3	2.4667E-03	1.5544E-04	516.19	2517.3	374.98	278.41	108.60	57.705	1.0348E+04	7.8279E+06	7.8279E+06
x(M)	0.0000	11.700	6.6000	0.0000	0.0000	9.3000	4.2000	10.800	0.0000	0.0000	0.0000
4	2.3656E-03	1.6167E-04	501.52	2702.7	359.34	296.55	105.88	62.527	1.1270E+04	7.8279E+06	7.8279E+06
x(M)	0.0000	11.400	6.6000	0.0000	0.0000	9.3000	4.2000	10.800	0.0000	0.0000	0.0000
5	2.3656E-03	1.5728E-04	459.56	2367.5	316.03	253.55	88.816	54.895	9257.4	7.8279E+06	7.8279E+06
x(M)	0.0000	12.000	6.9000	0.0000	0.0000	9.6000	4.2000	16.200	0.0000	0.0000	0.0000
6	2.3656E-03	1.5679E-04	490.15	2490.1	348.10	275.58	101.17	56.288	8701.1	7.8279E+06	7.8279E+06
x(M)	0.0000	11.700	6.6000	0.0000	0.0000	9.3000	4.2000	10.800	0.0000	0.0000	0.0000
7	2.2646E-03	1.5968E-04	558.62	3236.0	423.83	381.33	136.35	95.144	1.5129E+04	7.8279E+06	7.8279E+06
x(M)	0.0000	10.800	6.0000	0.0000	0.0000	8.7000	4.2000	10.800	0.0000	0.0000	0.0000
8	2.2646E-03	1.5902E-04	536.26	3008.0	399.18	349.54	125.74	84.821	1.3766E+04	7.8279E+06	7.8279E+06
x(M)	0.0000	11.100	6.3000	0.0000	0.0000	8.7000	4.2000	10.800	0.0000	0.0000	0.0000
9	2.2646E-03	1.5516E-04	554.07	3045.6	419.62	363.52	134.45	90.465	1.3096E+04	7.8279E+06	7.8279E+06
x(M)	0.0000	10.800	6.0000	0.0000	0.0000	8.7000	4.2000	10.800	0.0000	0.0000	0.0000
Max.	2.4667E-03	1.6167E-04	558.62	3236.0	423.83	381.33	136.35	95.144	1.5129E+04	7.8279E+06	7.8279E+06
Pile N.	1	4	7	7	7	7	7	7	7	1	1

LOAD CASE : 4
 CASE NAME : Load Case
 LOAD TYPE : Special, Sp

REDUCTION FACTORS FOR CLOSELY-SPACED PILE GROUPS, COMBINED Y AND Z DIRECTIONS ESTIMATED USING MOVEMENT IN THE DIRECTION OF PILE CAP DISPLACEMENTS

GROUP NO	P-FACTOR	Y-FACTOR
1	0.8452	1.0000
2	0.7881	1.0000
3	0.8661	1.0000
4	0.5723	1.0000
5	0.4962	1.0000
6	0.6023	1.0000

APPALTATORE: Consorzio Soci   	ITINERARIO NAPOLI – BARI RADDOPPIO TRATTA APICE – ORSARA I LOTTO FUNZIONALE APICE – HIRPINIA
PROGETTAZIONE: Mandataria Mandanti   	
PROGETTO ESECUTIVO RELAZIONE DI CALCOLO FONDAZIONI PILE P1, P2, P21, P22, P23 E P24	COMMESSA IF28 LOTTO 01 CODIFICA E ZZ CL DOCUMENTO VI0403 002 REV. B FOGLIO 121 di 161

7	0.5845	1.0000
8	0.5043	1.0000
9	0.6144	1.0000

* TABLE L * COMPUTATION ON PILE CAP

* EQUIVALENT CONCENTRATED LOAD AT ORIGIN *

VERT. LOAD, KN 29884.0	HOR. LOAD Y, KN -2824.80	HOR. LOAD Z, KN 8980.40
MOMENT X, KN- M 362.000	MOMENT Y, KN- M 1.02448E+05	MOMENT Z, KN- M 27465.9

* DISPLACEMENT OF GROUPED PILE FOUNDATION AT ORIGIN *

VERTICAL, M 1.68549E-03	HORIZONTAL Y, M -1.96906E-03	HORIZONTAL Z, M 6.35348E-03
ANGLE ROT. X, RAD -7.17255E-06	ANGLE ROT. Y, RAD 5.28294E-04	ANGLE ROT. Z, RAD 1.56571E-04

THE GLOBAL STRUCTURAL COORDINATE SYSTEM

* PILE TOP DISPLACEMENTS *

PILE GROUP	DISP. X, M	DISP. Y, M	DISP. Z, M	ROT. X, RAD	ROT. Y, RAD	ROT. Z, RAD
1	3.3582E-03	-1.9368E-03	6.3212E-03	-7.1725E-06	5.2829E-04	1.5657E-04
2	4.0628E-03	-1.9368E-03	6.3535E-03	-7.1725E-06	5.2829E-04	1.5657E-04
3	4.7674E-03	-1.9368E-03	6.3858E-03	-7.1725E-06	5.2829E-04	1.5657E-04
4	9.8092E-04	-1.9691E-03	6.3212E-03	-7.1725E-06	5.2829E-04	1.5657E-04
5	1.6855E-03	-1.9691E-03	6.3535E-03	-7.1725E-06	5.2829E-04	1.5657E-04
6	2.3901E-03	-1.9691E-03	6.3858E-03	-7.1725E-06	5.2829E-04	1.5657E-04
7	-1.3964E-03	-2.0013E-03	6.3212E-03	-7.1725E-06	5.2829E-04	1.5657E-04
8	-6.9183E-04	-2.0013E-03	6.3535E-03	-7.1725E-06	5.2829E-04	1.5657E-04
9	1.2736E-05	-2.0013E-03	6.3858E-03	-7.1725E-06	5.2829E-04	1.5657E-04
MINIMUM	-1.3964E-03	-2.0013E-03	6.3212E-03	-7.1725E-06	5.2829E-04	1.5657E-04
Pile N.	7	7	1	1	1	1
MAXIMUM	4.7674E-03	-1.9368E-03	6.3858E-03	-7.1725E-06	5.2829E-04	1.5657E-04
Pile N.	3	1	3	1	1	1

* PILE TOP REACTIONS *

PILE GROUP	FOR. X, KN	FOR. Y, KN	FOR. Z, KN	MOM X, KN- M	MOM Y, KN- M	MOM Z, KN- M
1	6896.4	-364.66	1176.3	-2.5367	-3026.2	-947.68
2	7881.8	-347.98	1130.1	-2.5367	-2942.1	-913.91
3	8867.2	-368.72	1206.0	-2.5367	-3108.7	-957.07
4	2121.2	-291.22	917.18	-2.5367	-2467.3	-797.21
5	3551.8	-264.65	838.88	-2.5367	-2302.6	-738.55
6	4982.3	-299.32	956.29	-2.5367	-2574.4	-816.70
7	-2934.6	-302.81	932.93	-2.5367	-2491.7	-827.43
8	-1510.5	-274.51	850.97	-2.5367	-2319.8	-765.14
9	28.304	-310.93	971.77	-2.5367	-2598.2	-846.99
MINIMUM	-2934.6	-368.72	838.88	-2.5367	-3108.7	-957.07
Pile N.	7	3	5	1	3	3
MAXIMUM	8867.2	-264.65	1206.0	-2.5367	-2302.6	-738.55
Pile N.	3	5	3	1	5	5

THE PILE COORDINATE SYSTEM (LOCAL AXES)

* PILE TOP DISPLACEMENTS *

PILE GROUP	DISP. x, M	DISP. y, M	DISP. z, M	ROT. x, RAD	ROT. y, RAD	ROT. z, RAD
1	3.3582E-03	-1.9368E-03	6.3212E-03	-7.1725E-06	5.2829E-04	1.5657E-04
2	4.0628E-03	-1.9368E-03	6.3535E-03	-7.1725E-06	5.2829E-04	1.5657E-04
3	4.7674E-03	-1.9368E-03	6.3858E-03	-7.1725E-06	5.2829E-04	1.5657E-04
4	9.8092E-04	-1.9691E-03	6.3212E-03	-7.1725E-06	5.2829E-04	1.5657E-04
5	1.6855E-03	-1.9691E-03	6.3535E-03	-7.1725E-06	5.2829E-04	1.5657E-04
6	2.3901E-03	-1.9691E-03	6.3858E-03	-7.1725E-06	5.2829E-04	1.5657E-04
7	-1.3964E-03	-2.0013E-03	6.3212E-03	-7.1725E-06	5.2829E-04	1.5657E-04
8	-6.9183E-04	-2.0013E-03	6.3535E-03	-7.1725E-06	5.2829E-04	1.5657E-04
9	1.2736E-05	-2.0013E-03	6.3858E-03	-7.1725E-06	5.2829E-04	1.5657E-04

APPALTATORE:

Consorzio

Soci



ITINERARIO NAPOLI – BARI

RADDOPPIO TRATTA APICE – ORSARA
I LOTTO FUNZIONALE APICE – HIRPINIA

PROGETTAZIONE:

Mandatario

Mandanti



PROGETTO ESECUTIVO

RELAZIONE DI CALCOLO FONDAZIONI PILE P1, P2, P21, P22, P23
E P24

COMMESSA	LOTTO	CODIFICA	DOCUMENTO	REV.	FOGLIO
IF28	01	E ZZ CL	VI0403 002	B	122 di 161

MINIMUM	-1.3964E-03	-2.0013E-03	6.3212E-03	-7.1725E-06	5.2829E-04	1.5657E-04
Pile N.	7	7	1	1	1	1
MAXIMUM	4.7674E-03	-1.9368E-03	6.3858E-03	-7.1725E-06	5.2829E-04	1.5657E-04
Pile N.	3	1	3	1	1	1

* PILE TOP REACTIONS *

PILE GROUP	AXIAL, KN	LAT. y, KN	LAT. z, KN	MOM x, KN- M	MOM y, KN- M	MOM z, KN- M
1	6896.4	-364.66	1176.3	-2.5367	-3026.2	-947.68
2	7881.8	-347.98	1130.1	-2.5367	-2942.1	-913.91
3	8867.2	-368.72	1206.0	-2.5367	-3108.7	-957.07
4	2121.2	-291.22	917.18	-2.5367	-2467.3	-797.21
5	3551.8	-264.65	838.88	-2.5367	-2302.6	-738.55
6	4982.3	-299.32	956.29	-2.5367	-2574.4	-816.70
7	-2934.6	-302.81	932.93	-2.5367	-2491.7	-827.43
8	-1510.5	-274.51	850.97	-2.5367	-2319.8	-765.14
9	28.304	-310.93	971.77	-2.5367	-2598.2	-846.99

MINIMUM	-2934.6	-368.72	838.88	-2.5367	-3108.7	-957.07
Pile N.	7	3	5	1	3	3
MAXIMUM	8867.2	-264.65	1206.0	-2.5367	-2302.6	-738.55
Pile N.	3	5	3	1	5	5

PILE GROUP	STRESS, KN/ M**2
1	1.3473E+04
2	1.3758E+04
3	1.4835E+04
4	9025.7
5	9308.1
6	1.0971E+04
7	9584.5
8	8226.9
9	8263.6

MINIMUM	8226.9
Pile N.	8
MAXIMUM	1.4835E+04
Pile N.	3

* EFFECTS FOR LATERALLY LOADED PILE *

* MINIMUM VALUES AND LOCATIONS *

PILE	DISPL. y-DIR	DISPL. z-DIR	MOMENT z-DIR	MOMENT y-DIR	SHEAR y-DIR	SHEAR z-DIR	SOIL REACT y-DIR	SOIL REACT z-DIR	TOTAL STRESS	FLEX. RIG. z-DIR	FLEX. RIG. y-DIR
	M	M	KN- M	KN- M	KN	KN	KN/ M	KN/ M	KN/ M**2	KN- M**2	KN- M**2
1	-1.9368E-03	-1.5496E-04	-478.52	-3026.2	-364.79	-367.16	-117.32	-92.078	3902.5	7.8279E+06	7.8279E+06
x(M)	0.0000	10.800	6.0000	0.0000	0.0000	8.7000	4.2000	10.800	30.000	0.0000	0.0000
2	-1.9368E-03	-1.5738E-04	-463.86	-2942.1	-348.12	-351.98	-110.17	-86.139	4460.2	7.8279E+06	7.8279E+06
x(M)	0.0000	10.800	6.3000	0.0000	0.0000	8.7000	4.2000	10.800	30.000	0.0000	0.0000
3	-1.9368E-03	-1.5619E-04	-482.83	-3108.7	-368.89	-376.30	-119.21	-94.880	5017.8	7.8279E+06	7.8279E+06
x(M)	0.0000	10.800	6.0000	0.0000	0.0000	8.7000	4.2000	10.800	30.000	0.0000	0.0000
4	-1.9691E-03	-1.5732E-04	-410.86	-2467.3	-291.25	-278.11	-85.232	-57.802	1200.4	7.8279E+06	7.8279E+06
x(M)	0.0000	11.700	6.6000	0.0000	0.0000	9.3000	4.2000	10.800	30.000	0.0000	0.0000
5	-1.9691E-03	-1.5691E-04	-385.65	-2302.6	-264.70	-253.06	-74.919	-54.457	2009.9	7.8279E+06	7.8279E+06
x(M)	0.0000	12.000	6.0000	0.0000	0.0000	9.6000	4.2000	16.200	30.000	0.0000	0.0000
6	-1.9691E-03	-1.5957E-04	-419.15	-2574.4	-299.40	-290.58	-88.682	-62.308	2819.4	7.8279E+06	7.8279E+06
x(M)	0.0000	11.400	6.0000	0.0000	0.0000	9.3000	4.2000	10.800	30.000	0.0000	0.0000
7	-2.0013E-03	-1.5626E-04	-420.82	-2491.7	-302.76	-280.51	-88.541	-59.105	1660.6	7.8279E+06	7.8279E+06
x(M)	0.0000	11.400	6.6000	0.0000	0.0000	9.3000	4.2000	10.800	30.000	0.0000	0.0000
8	-2.0013E-03	-1.5604E-04	-394.19	-2319.8	-274.49	-254.36	-77.515	-54.587	854.74	7.8279E+06	7.8279E+06
x(M)	0.0000	11.700	6.6000	0.0000	0.0000	9.6000	4.2000	16.200	30.000	0.0000	0.0000
9	-2.0013E-03	-1.5863E-04	-429.11	-2598.2	-310.93	-292.82	-92.017	-63.590	16.017	7.8279E+06	7.8279E+06
x(M)	0.0000	11.400	6.6000	0.0000	0.0000	9.3000	4.2000	10.800	30.000	0.0000	0.0000
Min.	-2.0013E-03	-1.5957E-04	-482.83	-3108.7	-368.89	-376.30	-119.21	-94.880	16.017	7.8279E+06	7.8279E+06
Pile N.	7	6	3	3	3	3	3	3	9	1	1

* MAXIMUM VALUES AND LOCATIONS *

PILE	DISPL. y-DIR	DISPL. z-DIR	MOMENT z-DIR	MOMENT y-DIR	SHEAR y-DIR	SHEAR z-DIR	SOIL REACT y-DIR	SOIL REACT z-DIR	TOTAL STRESS	FLEX. RIG. z-DIR	FLEX. RIG. y-DIR
	M	M	KN- M	KN- M	KN	KN	KN/ M	KN/ M	KN/ M**2	KN- M**2	KN- M**2
1	4.7704E-05	6.3212E-03	947.68	1559.4	112.92	1176.7	28.346	380.02	1.3473E+04	7.8279E+06	7.8279E+06
x(M)	10.800	0.0000	0.0000	6.0000	8.7000	0.0000	10.800	4.2000	0.0000	0.0000	0.0000
2	4.8152E-05	6.3535E-03	913.91	1518.8	107.58	1130.5	26.356	359.07	1.3758E+04	7.8279E+06	7.8279E+06
x(M)	10.800	0.0000	0.0000	6.3000	8.7000	0.0000	10.800	4.2000	0.0000	0.0000	0.0000
3	4.7530E-05	6.3858E-03	957.07	1590.2	114.44	1206.5	28.873	391.00	1.4835E+04	7.8279E+06	7.8279E+06
x(M)	10.800	0.0000	0.0000	6.0000	8.7000	0.0000	10.800	4.2000	0.0000	0.0000	0.0000
4	4.9335E-05	6.3212E-03	797.21	1315.2	87.104	917.28	18.029	270.45	9025.7	7.8279E+06	7.8279E+06
x(M)	11.700	0.0000	0.0000	6.0000	9.3000	0.0000	10.800	4.2000	0.0000	0.0000	0.0000
5	4.8907E-05	6.3535E-03	738.55	1242.3	78.851	839.04	17.124	239.20	9308.1	7.8279E+06	7.8279E+06
x(M)	12.000	0.0000	0.0000	6.6000	9.6000	0.0000	16.200	4.2000	0.0000	0.0000	0.0000
6	4.9438E-05	6.3858E-03	816.70	1355.9	90.035	956.54	19.248	284.97	1.0971E+04	7.8279E+06	7.8279E+06

APPALTATORE: Consorzio Soci   	ITINERARIO NAPOLI – BARI RADDOPPIO TRATTA APICE – ORSARA I LOTTO FUNZIONALE APICE – HIRPINIA
PROGETTAZIONE: Mandataria Mandanti   	
PROGETTO ESECUTIVO RELAZIONE DI CALCOLO FONDAZIONI PILE P1, P2, P21, P22, P23 E P24	
	COMMESSA IF28 LOTTO 01 CODIFICA E ZZ CL DOCUMENTO VI0403 002 REV. B FOGLIO 123 di 161

x(M)	11.400	0.0000	0.0000	6.6000	9.3000	0.0000	10.800	4.2000	0.0000	0.0000	0.0000
7	4.9880E-05	6.3212E-03	827.43	1323.9	89.470	932.79	18.754	275.43	9584.5	7.8279E+06	7.8279E+06
x(M)	11.700	0.0000	0.0000	6.6000	9.3000	0.0000	10.800	4.2000	0.0000	0.0000	0.0000
8	4.9492E-05	6.3535E-03	765.14	1248.4	80.720	850.91	17.536	242.61	8226.9	7.8279E+06	7.8279E+06
x(M)	12.000	0.0000	0.0000	6.6000	9.6000	0.0000	16.200	4.2000	0.0000	0.0000	0.0000
9	5.0059E-05	6.3858E-03	846.99	1364.2	92.411	971.77	19.988	289.88	8263.6	7.8279E+06	7.8279E+06
x(M)	11.400	0.0000	0.0000	6.6000	9.3000	0.0000	10.800	4.2000	0.0000	0.0000	0.0000
Max.	5.0059E-05	6.3858E-03	957.07	1590.2	114.44	1206.5	28.873	391.00	1.4835E+04	7.8279E+06	7.8279E+06
Pile N.	9	3	3	3	3	3	3	3	3	1	1

LOAD CASE : 5
CASE NAME : Load Case
LOAD TYPE : Special, Sp

REDUCTION FACTORS FOR CLOSELY-SPACED PILE GROUPS, COMBINED Y AND Z DIRECTIONS
ESTIMATED USING MOVEMENT IN THE DIRECTION OF PILE CAP DISPLACEMENTS

GROUP NO	P-FACTOR	Y-FACTOR
1	0.7266	1.0000
2	0.6915	1.0000
3	0.8661	1.0000
4	0.5358	1.0000
5	0.4962	1.0000
6	0.7111	1.0000
7	0.5845	1.0000
8	0.5430	1.0000
9	0.7509	1.0000

* TABLE L * COMPUTATION ON PILE CAP

* EQUIVALENT CONCENTRATED LOAD AT ORIGIN *

VERT. LOAD, KN	HOR. LOAD Y, KN	HOR. LOAD Z, KN
38962.0	-3041.50	2693.90
MOMENT X, KN- M	MOMENT Y, KN- M	MOMENT Z, KN- M
109.000	30893.0	30207.7

* DISPLACEMENT OF GROUPED PILE FOUNDATION AT ORIGIN *

VERTICAL, M	HORIZONTAL Y, M	HORIZONTAL Z, M
2.07499E-03	-1.70799E-03	1.56430E-03
ANGLE ROT. X, RAD	ANGLE ROT. Y, RAD	ANGLE ROT. Z, RAD
1.85683E-06	1.54070E-04	1.55618E-04

THE GLOBAL STRUCTURAL COORDINATE SYSTEM

* PILE TOP DISPLACEMENTS *

PILE GROUP	DISP. X, M	DISP. Y, M	DISP. Z, M	ROT. X, RAD	ROT. Y, RAD	ROT. Z, RAD
1	2.0680E-03	-1.7163E-03	1.5727E-03	1.8568E-06	1.5407E-04	1.5562E-04
2	2.7683E-03	-1.7163E-03	1.5643E-03	1.8568E-06	1.5407E-04	1.5562E-04
3	3.4686E-03	-1.7163E-03	1.5559E-03	1.8568E-06	1.5407E-04	1.5562E-04
4	1.3747E-03	-1.7080E-03	1.5727E-03	1.8568E-06	1.5407E-04	1.5562E-04
5	2.0750E-03	-1.7080E-03	1.5643E-03	1.8568E-06	1.5407E-04	1.5562E-04
6	2.7753E-03	-1.7080E-03	1.5559E-03	1.8568E-06	1.5407E-04	1.5562E-04
7	6.8140E-04	-1.6996E-03	1.5727E-03	1.8568E-06	1.5407E-04	1.5562E-04
8	1.3817E-03	-1.6996E-03	1.5643E-03	1.8568E-06	1.5407E-04	1.5562E-04
9	2.0820E-03	-1.6996E-03	1.5559E-03	1.8568E-06	1.5407E-04	1.5562E-04
MINIMUM	6.8140E-04	-1.7163E-03	1.5559E-03	1.8568E-06	1.5407E-04	1.5562E-04
Pile N.	7	1	3	1	1	1
MAXIMUM	3.4686E-03	-1.6996E-03	1.5727E-03	1.8568E-06	1.5407E-04	1.5562E-04
Pile N.	3	7	1	1	1	1

* PILE TOP REACTIONS *

PILE GROUP	FOR. X, KN	FOR. Y, KN	FOR. Z, KN	MOM X, KN- M	MOM Y, KN- M	MOM Z, KN- M
1	4328.5	-367.69	326.46	0.6567	-790.43	-914.83
2	5750.3	-358.05	315.34	0.6567	-767.31	-897.40
3	7050.7	-403.05	352.91	0.6567	-834.56	-981.80
4	2920.8	-295.11	263.13	0.6567	-655.59	-757.50
5	4342.6	-281.58	248.93	0.6567	-624.47	-730.13

APPALTATORE: Consorzio Soci   		ITINERARIO NAPOLI – BARI RADDOPPIO TRATTA APICE – ORSARA I LOTTO FUNZIONALE APICE – HIRPINIA					
PROGETTAZIONE: Mandataria Mandanti   							
PROGETTO ESECUTIVO RELAZIONE DI CALCOLO FONDAZIONI PILE P1, P2, P21, P22, P23 E P24							COMMESSA IF28

6	5764.4	-361.21	317.91	0.6567	-769.35	-900.62
7	1513.1	-309.33	277.93	0.6567	-685.29	-783.61
8	2934.9	-295.77	263.52	0.6567	-654.10	-756.59
9	4356.7	-369.71	327.76	0.6567	-787.18	-912.97
MINIMUM	1513.1	-403.05	248.93	0.6567	-834.56	-981.80
Pile N.	7	3	5	1	3	3
MAXIMUM	7050.7	-281.58	352.91	0.6567	-624.47	-730.13
Pile N.	3	5	3	1	5	5

THE PILE COORDINATE SYSTEM (LOCAL AXES)

* PILE TOP DISPLACEMENTS *

PILE GROUP	DISP. x, M	DISP. y, M	DISP. z, M	ROT. x,RAD	ROT. y,RAD	ROT. z,RAD
*****	*****	*****	*****	*****	*****	*****
1	2.0680E-03	-1.7163E-03	1.5727E-03	1.8568E-06	1.5407E-04	1.5562E-04
2	2.7683E-03	-1.7163E-03	1.5643E-03	1.8568E-06	1.5407E-04	1.5562E-04
3	3.4686E-03	-1.7163E-03	1.5559E-03	1.8568E-06	1.5407E-04	1.5562E-04
4	1.3747E-03	-1.7080E-03	1.5727E-03	1.8568E-06	1.5407E-04	1.5562E-04
5	2.0750E-03	-1.7080E-03	1.5643E-03	1.8568E-06	1.5407E-04	1.5562E-04
6	2.7753E-03	-1.7080E-03	1.5559E-03	1.8568E-06	1.5407E-04	1.5562E-04
7	6.8140E-04	-1.6996E-03	1.5727E-03	1.8568E-06	1.5407E-04	1.5562E-04
8	1.3817E-03	-1.6996E-03	1.5643E-03	1.8568E-06	1.5407E-04	1.5562E-04
9	2.0820E-03	-1.6996E-03	1.5559E-03	1.8568E-06	1.5407E-04	1.5562E-04
MINIMUM	6.8140E-04	-1.7163E-03	1.5559E-03	1.8568E-06	1.5407E-04	1.5562E-04
Pile N.	7	1	3	1	1	1
MAXIMUM	3.4686E-03	-1.6996E-03	1.5727E-03	1.8568E-06	1.5407E-04	1.5562E-04
Pile N.	3	7	1	1	1	1

* PILE TOP REACTIONS *

PILE GROUP	AXIAL, KN	LAT. y, KN	LAT. z, KN	MOM x, KN- M	MOM y, KN- M	MOM z, KN- M
*****	*****	*****	*****	*****	*****	*****
1	4328.5	-367.69	326.46	0.6567	-790.43	-914.83
2	5750.3	-358.05	315.34	0.6567	-767.31	-897.40
3	7050.7	-403.05	352.91	0.6567	-834.56	-981.80
4	2920.8	-295.11	263.13	0.6567	-655.59	-757.50
5	4342.6	-281.58	248.93	0.6567	-624.47	-730.13
6	5764.4	-361.21	317.91	0.6567	-769.35	-900.62
7	1513.1	-309.33	277.93	0.6567	-685.29	-783.61
8	2934.9	-295.77	263.52	0.6567	-654.10	-756.59
9	4356.7	-369.71	327.76	0.6567	-787.18	-912.97
MINIMUM	1513.1	-403.05	248.93	0.6567	-834.56	-981.80
Pile N.	7	3	5	1	3	3
MAXIMUM	7050.7	-281.58	352.91	0.6567	-624.47	-730.13
Pile N.	3	5	3	1	5	5

* PILE GROUP STRESS, KN/ M**2

PILE GROUP	STRESS, KN/ M**2
*****	*****
1	6098.2
2	6817.5
3	7878.8
4	4676.3
5	5357.0
6	6836.9
7	3998.0
8	4679.3
9	6103.6
MINIMUM	3998.0
Pile N.	7
MAXIMUM	7878.8
Pile N.	3

* EFFECTS FOR Laterally LOADED PILE *

* MINIMUM VALUES AND LOCATIONS *

PILE	DISPL. y-DIR	DISPL. z-DIR	MOMENT z-DIR	MOMENT y-DIR	SHEAR y-DIR	SHEAR z-DIR	SOIL REACT y-DIR	SOIL REACT z-DIR	TOTAL STRESS	FLEX. RIG. z-DIR	FLEX. RIG. y-DIR
*****	*****	*****	*****	*****	*****	*****	*****	*****	*****	*****	*****
	M	M	KN- M	KN- M	KN	KN	KN/ M	KN/ M	KN/ M**2	KN- M**2	KN- M**2
1	-1.7163E-03	-3.9248E-05	-521.30	-790.43	-367.77	-127.11	-150.56	-42.184	2449.4	7.8279E+06	7.8279E+06
x(M)	0.0000	9.9000	5.7000	0.0000	0.0000	7.8000	4.2000	10.800	30.000	0.0000	0.0000
2	-1.7163E-03	-3.9849E-05	-513.52	-767.31	-358.14	-123.30	-145.14	-41.456	3254.0	7.8279E+06	7.8279E+06
x(M)	0.0000	9.9000	5.7000	0.0000	0.0000	7.8000	4.2000	10.800	30.000	0.0000	0.0000
3	-1.7163E-03	-3.6001E-05	-550.78	-834.56	-403.18	-137.11	-172.23	-42.847	3989.9	7.8279E+06	7.8279E+06
x(M)	0.0000	9.6000	5.7000	0.0000	0.0000	7.8000	4.2000	10.800	30.000	0.0000	0.0000
4	-1.7080E-03	-4.4431E-05	-434.07	-655.59	-295.16	-94.946	-110.37	-27.293	1652.8	7.8279E+06	7.8279E+06
x(M)	0.0000	10.800	6.0000	0.0000	0.0000	8.4000	4.2000	10.800	30.000	0.0000	0.0000
5	-1.7080E-03	-4.5435E-05	-420.72	-624.47	-281.65	-89.675	-103.43	-25.363	2457.4	7.8279E+06	7.8279E+06
x(M)	0.0000	10.800	6.0000	0.0000	0.0000	8.4000	4.2000	10.800	30.000	0.0000	0.0000
6	-1.7080E-03	-3.9110E-05	-515.93	-769.35	-361.31	-124.57	-147.75	-41.529	3262.0	7.8279E+06	7.8279E+06

APPALTATORE: Consorzio Soci 		ITINERARIO NAPOLI – BARI					
PROGETTAZIONE: Mandataria Mandanti 		RADDOPPIO TRATTA APICE – ORSARA I LOTTO FUNZIONALE APICE – HIRPINIA					
PROGETTO ESECUTIVO RELAZIONE DI CALCOLO FONDAZIONI PILE P1, P2, P21, P22, P23 E P24		COMMESSA IF28	LOTTO 01	CODIFICA E ZZ CL	DOCUMENTO VI0403 002	REV. B	FOGLIO 125 di 161

x(M)	0.0000	9.9000	5.7000	0.0000	0.0000	7.8000	4.2000	10.800	30.000	0.0000	0.0000
7	-1.6996E-03	-4.2891E-05	-447.63	-685.29	-309.36	-100.52	-118.37	-29.415	856.23	7.8279E+06	7.8279E+06
x(M)	0.0000	10.500	6.0000	0.0000	0.0000	8.4000	4.2000	10.800	30.000	0.0000	0.0000
8	-1.6996E-03	-4.3901E-05	-434.77	-654.10	-295.81	-95.431	-111.27	-27.530	1660.8	7.8279E+06	7.8279E+06
x(M)	0.0000	10.800	6.0000	0.0000	0.0000	8.4000	4.2000	10.800	30.000	0.0000	0.0000
9	-1.6996E-03	-3.8120E-05	-522.18	-787.18	-369.78	-128.08	-153.28	-42.029	2465.4	7.8279E+06	7.8279E+06
x(M)	0.0000	9.9000	5.7000	0.0000	0.0000	7.8000	4.2000	10.800	30.000	0.0000	0.0000
Min.	-1.7163E-03	-4.5435E-05	-550.78	-834.56	-403.18	-137.11	-172.23	-42.847	856.23	7.8279E+06	7.8279E+06
Pile N.	1	5	3	3	3	3	3	3	7	1	1

* MAXIMUM VALUES AND LOCATIONS *

PILE	DISPL. y-DIR	DISPL. z-DIR	MOMENT z-DIR	MOMENT y-DIR	SHEAR y-DIR	SHEAR z-DIR	SOIL REACT y-DIR	SOIL REACT z-DIR	TOTAL STRESS	FLEX. RIG. z-DIR	FLEX. RIG. y-DIR
	M	M	KN- M	KN- M	KN	KN	KN/ M	KN/ M	KN/ M**2	KN- M**2	KN- M**2
*****	*****	*****	*****	*****	*****	*****	*****	*****	*****	*****	*****
1	4.3342E-05	1.5727E-03	914.83	474.60	139.89	326.52	46.828	135.22	6098.2	7.8279E+06	7.8279E+06
x(M)	9.9000	0.0000	0.0000	5.7000	7.8000	0.0000	10.800	4.2000	0.0000	0.0000	0.0000
2	4.4254E-05	1.5643E-03	897.40	464.97	136.43	315.42	46.305	129.46	6817.5	7.8279E+06	7.8279E+06
x(M)	9.9000	0.0000	0.0000	5.7000	7.8000	0.0000	10.800	4.2000	0.0000	0.0000	0.0000
3	4.0229E-05	1.5559E-03	981.80	495.05	152.98	353.03	48.262	152.63	7878.8	7.8279E+06	7.8279E+06
x(M)	9.6000	0.0000	0.0000	5.7000	7.8000	0.0000	10.800	4.2000	0.0000	0.0000	0.0000
4	4.8863E-05	1.5727E-03	757.50	397.78	103.87	263.17	30.015	99.664	4676.3	7.8279E+06	7.8279E+06
x(M)	10.800	0.0000	0.0000	6.0000	8.4000	0.0000	10.800	4.2000	0.0000	0.0000	0.0000
5	5.0231E-05	1.5643E-03	730.13	383.64	98.551	248.98	28.040	92.746	5357.0	7.8279E+06	7.8279E+06
x(M)	10.800	0.0000	0.0000	6.0000	8.4000	0.0000	10.800	4.2000	0.0000	0.0000	0.0000
6	4.3476E-05	1.5559E-03	900.62	466.80	137.96	318.00	46.430	131.70	6836.9	7.8279E+06	7.8279E+06
x(M)	9.9000	0.0000	0.0000	5.7000	7.8000	0.0000	10.800	4.2000	0.0000	0.0000	0.0000
7	4.6865E-05	1.5727E-03	783.61	412.04	109.52	277.95	32.196	107.56	3998.0	7.8279E+06	7.8279E+06
x(M)	10.500	0.0000	0.0000	6.0000	8.4000	0.0000	10.800	4.2000	0.0000	0.0000	0.0000
8	4.8318E-05	1.5643E-03	756.59	398.16	104.48	263.56	30.300	100.41	4679.3	7.8279E+06	7.8279E+06
x(M)	10.800	0.0000	0.0000	6.0000	8.4000	0.0000	10.800	4.2000	0.0000	0.0000	0.0000
9	4.2161E-05	1.5559E-03	912.97	474.79	141.16	327.83	46.730	137.48	6103.6	7.8279E+06	7.8279E+06
x(M)	9.9000	0.0000	0.0000	5.7000	7.8000	0.0000	10.800	4.2000	0.0000	0.0000	0.0000
Max.	5.0231E-05	1.5727E-03	981.80	495.05	152.98	353.03	48.262	152.63	7878.8	7.8279E+06	7.8279E+06
Pile N.	5	1	3	3	3	3	3	3	3	1	1

LOAD CASE : 6
CASE NAME : Load Case
LOAD TYPE : Special, Sp

REDUCTION FACTORS FOR CLOSELY-SPACED PILE GROUPS, COMBINED Y AND Z DIRECTIONS
ESTIMATED USING MOVEMENT IN THE DIRECTION OF PILE CAP DISPLACEMENTS

GROUP NO	P-FACTOR	Y-FACTOR
1	0.7609	1.0000
2	0.5460	1.0000
3	0.5845	1.0000
4	0.7192	1.0000
5	0.4962	1.0000
6	0.5327	1.0000
7	0.8661	1.0000
8	0.6830	1.0000
9	0.7161	1.0000

* TABLE L * COMPUTATION ON PILE CAP

* EQUIVALENT CONCENTRATED LOAD AT ORIGIN *

VERT. LOAD, KN	HOR. LOAD Y, KN	HOR. LOAD Z, KN
13590.0	3258.20	-2693.90
MOMENT X, KN- M	MOMENT Y, KN- M	MOMENT Z, KN- M
-109.000	-30718.0	-32877.9

* DISPLACEMENT OF GROUPED PILE FOUNDATION AT ORIGIN *

VERTICAL, M	HORIZONTAL Y, M	HORIZONTAL Z, M
7.06870E-04	1.81423E-03	-1.54026E-03
ANGLE ROT. X, RAD	ANGLE ROT. Y, RAD	ANGLE ROT. Z, RAD
-9.29388E-07	-1.45194E-04	-1.59920E-04

THE GLOBAL STRUCTURAL COORDINATE SYSTEM

APPALTATORE: Consorzio  Soci  		ITINERARIO NAPOLI – BARI RADDOPPIO TRATTA APICE – ORSARA I LOTTO FUNZIONALE APICE – HIRPINIA					
PROGETTAZIONE: Mandataria  Mandanti  							
PROGETTO ESECUTIVO RELAZIONE DI CALCOLO FONDAZIONI PILE P1, P2, P21, P22, P23 E P24							COMMESSA IF28

* PILE TOP DISPLACEMENTS *

PILE GROUP	DISP. X, M	DISP. Y, M	DISP. Z, M	ROT. X,RAD	ROT. Y,RAD	ROT. Z,RAD
*****	*****	*****	*****	*****	*****	*****
1	7.7313E-04	1.8184E-03	-1.5444E-03	-9.2939E-07	-1.4519E-04	-1.5992E-04
2	5.3495E-05	1.8184E-03	-1.5403E-03	-9.2939E-07	-1.4519E-04	-1.5992E-04
3	-6.6615E-04	1.8184E-03	-1.5361E-03	-9.2939E-07	-1.4519E-04	-1.5992E-04
4	1.4265E-04	1.8142E-03	-1.5444E-03	-9.2939E-07	-1.4519E-04	-1.5992E-04
5	7.0687E-04	1.8142E-03	-1.5403E-03	-9.2939E-07	-1.4519E-04	-1.5992E-04
6	-1.2770E-05	1.8142E-03	-1.5361E-03	-9.2939E-07	-1.4519E-04	-1.5992E-04
7	2.0799E-03	1.8100E-03	-1.5444E-03	-9.2939E-07	-1.4519E-04	-1.5992E-04
8	1.3602E-03	1.8100E-03	-1.5403E-03	-9.2939E-07	-1.4519E-04	-1.5992E-04
9	6.4061E-04	1.8100E-03	-1.5361E-03	-9.2939E-07	-1.4519E-04	-1.5992E-04
MINIMUM	-6.6615E-04	1.8100E-03	-1.5444E-03	-9.2939E-07	-1.4519E-04	-1.5992E-04
Pile N.	3	7	1	1	1	1
MAXIMUM	2.0799E-03	1.8184E-03	-1.5361E-03	-9.2939E-07	-1.4519E-04	-1.5992E-04
Pile N.	7	1	3	1	1	1

* PILE TOP REACTIONS *

PILE GROUP	FOR. X, KN	FOR. Y, KN	FOR. Z, KN	MOM X, KN- M	MOM Y, KN- M	MOM Z, KN- M
*****	*****	*****	*****	*****	*****	*****
1	1699.3	402.49	-333.23	-0.3287	813.00	1003.4
2	118.89	320.99	-264.11	-0.3287	665.93	830.90
3	-1458.5	334.80	-274.55	-0.3287	685.35	858.43
4	3025.9	389.30	-323.21	-0.3287	794.89	977.92
5	1564.8	301.83	-248.97	-0.3287	635.18	790.61
6	-28.045	315.45	-259.32	-0.3287	654.81	818.19
7	4352.5	427.67	-356.56	-0.3287	857.24	1048.3
8	2891.4	377.87	-313.42	-0.3287	774.92	954.79
9	1423.7	387.79	-320.52	-0.3287	786.23	972.84
MINIMUM	-1458.5	301.83	-356.56	-0.3287	635.18	790.61
Pile N.	3	5	7	1	5	5
MAXIMUM	4352.5	427.67	-248.97	-0.3287	857.24	1048.3
Pile N.	7	7	5	1	7	7

THE PILE COORDINATE SYSTEM (LOCAL AXES)

* PILE TOP DISPLACEMENTS *

PILE GROUP	DISP. x, M	DISP. y, M	DISP. z, M	ROT. x,RAD	ROT. y,RAD	ROT. z,RAD
*****	*****	*****	*****	*****	*****	*****
1	7.7313E-04	1.8184E-03	-1.5444E-03	-9.2939E-07	-1.4519E-04	-1.5992E-04
2	5.3495E-05	1.8184E-03	-1.5403E-03	-9.2939E-07	-1.4519E-04	-1.5992E-04
3	-6.6615E-04	1.8184E-03	-1.5361E-03	-9.2939E-07	-1.4519E-04	-1.5992E-04
4	1.4265E-04	1.8142E-03	-1.5444E-03	-9.2939E-07	-1.4519E-04	-1.5992E-04
5	7.0687E-04	1.8142E-03	-1.5403E-03	-9.2939E-07	-1.4519E-04	-1.5992E-04
6	-1.2770E-05	1.8142E-03	-1.5361E-03	-9.2939E-07	-1.4519E-04	-1.5992E-04
7	2.0799E-03	1.8100E-03	-1.5444E-03	-9.2939E-07	-1.4519E-04	-1.5992E-04
8	1.3602E-03	1.8100E-03	-1.5403E-03	-9.2939E-07	-1.4519E-04	-1.5992E-04
9	6.4061E-04	1.8100E-03	-1.5361E-03	-9.2939E-07	-1.4519E-04	-1.5992E-04
MINIMUM	-6.6615E-04	1.8100E-03	-1.5444E-03	-9.2939E-07	-1.4519E-04	-1.5992E-04
Pile N.	3	7	1	1	1	1
MAXIMUM	2.0799E-03	1.8184E-03	-1.5361E-03	-9.2939E-07	-1.4519E-04	-1.5992E-04
Pile N.	7	1	3	1	1	1

* PILE TOP REACTIONS *

PILE GROUP	AXIAL, KN	LAT. y, KN	LAT. z, KN	MOM x, KN- M	MOM y, KN- M	MOM z, KN- M
*****	*****	*****	*****	*****	*****	*****
1	1699.3	402.49	-333.23	-0.3287	813.00	1003.4
2	118.89	320.99	-264.11	-0.3287	665.93	830.90
3	-1458.5	334.80	-274.55	-0.3287	685.35	858.43
4	3025.9	389.30	-323.21	-0.3287	794.89	977.92
5	1564.8	301.83	-248.97	-0.3287	635.18	790.61
6	-28.045	315.45	-259.32	-0.3287	654.81	818.19
7	4352.5	427.67	-356.56	-0.3287	857.24	1048.3
8	2891.4	377.87	-313.42	-0.3287	774.92	954.79
9	1423.7	387.79	-320.52	-0.3287	786.23	972.84
MINIMUM	-1458.5	301.83	-356.56	-0.3287	635.18	790.61
Pile N.	3	5	7	1	5	5
MAXIMUM	4352.5	427.67	-248.97	-0.3287	857.24	1048.3
Pile N.	7	7	5	1	7	7

PILE GROUP	STRESS, KN/ M**2
*****	*****
1	4859.2
2	3281.0
3	4140.6
4	5515.8
5	3946.3
6	3178.7

APPALTATORE:

Consorzio

Soci



ITINERARIO NAPOLI – BARI

PROGETTAZIONE:

Mandataria

Mandanti

RADDOPPIO TRATTA APICE – ORSARA
I LOTTO FUNZIONALE APICE – HIRPINIA

PROGETTO ESECUTIVO

RELAZIONE DI CALCOLO FONDAZIONI PILE P1, P2, P21, P22, P23
E P24COMMESSA
IF28LOTTO
01CODIFICA
E ZZ CLDOCUMENTO
VI0403 002REV.
BFOGLIO
127 di
1617 6550.1
8 5347.4
9 4580.7MINIMUM 3178.7
Pile N. 6
MAXIMUM 6550.1
Pile N. 7

* EFFECTS FOR Laterally LOADED PILE *

* MINIMUM VALUES AND LOCATIONS *



PILE	DISPL. y-DIR	DISPL. z-DIR	MOMENT z-DIR	MOMENT y-DIR	SHEAR y-DIR	SHEAR z-DIR	SOIL REACT y-DIR	SOIL REACT z-DIR	TOTAL STRESS	FLEX. RIG. z-DIR	FLEX. RIG. y-DIR
	M	M	KN- M	KN- M	KN	KN	KN/ M	KN/ M	KN/ M**2	KN- M**2	KN- M**2
1	-4.5342E-05	-1.5444E-03	-1003.4	-471.69	-150.94	-333.26	-50.031	-137.18	961.63	7.8279E+06	7.8279E+06
x (M)	9.9000	0.0000	0.0000	5.7000	7.8000	0.0000	10.800	4.2000	30.000	0.0000	0.0000
2	-5.1863E-05	-1.5403E-03	-830.90	-390.47	-110.87	-264.11	-32.027	-98.716	67.276	7.8279E+06	7.8279E+06
x (M)	10.800	0.0000	0.0000	6.0000	8.4000	0.0000	10.800	4.2000	30.000	0.0000	0.0000
3	-5.0350E-05	-1.5361E-03	-858.43	-400.21	-116.05	-274.53	-33.980	-104.37	825.36	7.8279E+06	7.8279E+06
x (M)	10.800	0.0000	0.0000	6.0000	8.4000	0.0000	10.800	4.2000	30.000	0.0000	0.0000
4	-4.6347E-05	-1.5444E-03	-977.92	-463.70	-146.30	-323.26	-49.285	-131.50	1712.3	7.8279E+06	7.8279E+06
x (M)	9.9000	0.0000	0.0000	5.7000	7.8000	0.0000	10.800	4.2000	30.000	0.0000	0.0000
5	-5.3435E-05	-1.5403E-03	-790.61	-375.48	-103.32	-248.98	-29.271	-90.943	885.50	7.8279E+06	7.8279E+06
x (M)	10.800	0.0000	0.0000	6.0000	8.4000	0.0000	10.800	4.2000	30.000	0.0000	0.0000
6	-5.2183E-05	-1.5361E-03	-818.19	-385.61	-108.77	-259.32	-31.284	-96.435	15.871	7.8279E+06	7.8279E+06
x (M)	10.800	0.0000	0.0000	6.0000	8.4000	0.0000	10.800	4.2000	30.000	0.0000	0.0000
7	-4.2692E-05	-1.5444E-03	-1048.3	-490.95	-160.43	-356.63	-50.849	-151.40	2463.0	7.8279E+06	7.8279E+06
x (M)	9.6000	0.0000	0.0000	5.7000	7.8000	0.0000	10.800	4.2000	30.000	0.0000	0.0000
8	-4.7137E-05	-1.5403E-03	-954.79	-454.99	-141.91	-313.47	-48.494	-126.13	1636.2	7.8279E+06	7.8279E+06
x (M)	9.9000	0.0000	0.0000	5.7000	7.8000	0.0000	10.800	4.2000	30.000	0.0000	0.0000
9	-4.6225E-05	-1.5361E-03	-972.84	-460.50	-145.57	-320.55	-49.114	-130.42	805.63	7.8279E+06	7.8279E+06
x (M)	9.9000	0.0000	0.0000	5.7000	7.8000	0.0000	10.800	4.2000	30.000	0.0000	0.0000
Min.	-5.3435E-05	-1.5444E-03	-1048.3	-490.95	-160.43	-356.63	-50.849	-151.40	15.871	7.8279E+06	7.8279E+06
Pile N.	5	1	7	7	7	7	7	7	6	1	1

* MAXIMUM VALUES AND LOCATIONS *

PILE	DISPL. y-DIR	DISPL. z-DIR	MOMENT z-DIR	MOMENT y-DIR	SHEAR y-DIR	SHEAR z-DIR	SOIL REACT y-DIR	SOIL REACT z-DIR	TOTAL STRESS	FLEX. RIG. z-DIR	FLEX. RIG. y-DIR
	M	M	KN- M	KN- M	KN	KN	KN/ M	KN/ M	KN/ M**2	KN- M**2	KN- M**2
1	1.8184E-03	3.8126E-05	558.41	813.00	402.53	127.28	164.19	41.893	4859.2	7.8279E+06	7.8279E+06
x (M)	0.0000	9.9000	5.7000	0.0000	0.0000	7.8000	4.2000	10.800	0.0000	0.0000	0.0000
2	1.8184E-03	4.3426E-05	463.01	665.93	320.99	93.282	118.64	26.817	3281.0	7.8279E+06	7.8279E+06
x (M)	0.0000	10.800	6.0000	0.0000	0.0000	8.4000	4.2000	10.800	0.0000	0.0000	0.0000
3	1.8184E-03	4.2049E-05	476.22	685.35	334.78	97.254	125.85	28.340	4140.6	7.8279E+06	7.8279E+06
x (M)	0.0000	10.500	6.0000	0.0000	0.0000	8.4000	4.2000	10.800	0.0000	0.0000	0.0000
4	1.8142E-03	3.9092E-05	547.44	794.89	389.36	123.73	156.95	41.396	5515.8	7.8279E+06	7.8279E+06
x (M)	0.0000	9.9000	5.7000	0.0000	0.0000	7.8000	4.2000	10.800	0.0000	0.0000	0.0000
5	1.8142E-03	4.4910E-05	443.79	635.18	301.85	87.275	109.00	24.601	3946.3	7.8279E+06	7.8279E+06
x (M)	0.0000	10.800	6.0000	0.0000	0.0000	8.4000	4.2000	10.800	0.0000	0.0000	0.0000
6	1.8142E-03	4.3683E-05	457.37	654.81	315.45	91.505	115.97	26.188	3178.7	7.8279E+06	7.8279E+06
x (M)	0.0000	10.800	6.0000	0.0000	0.0000	8.4000	4.2000	10.800	0.0000	0.0000	0.0000
7	1.8100E-03	3.6115E-05	578.66	857.24	427.76	135.86	180.16	42.786	6550.1	7.8279E+06	7.8279E+06
x (M)	0.0000	9.6000	5.7000	0.0000	0.0000	7.8000	4.2000	10.800	0.0000	0.0000	0.0000
8	1.8100E-03	3.9756E-05	537.25	774.92	377.92	120.02	150.63	40.723	5347.4	7.8279E+06	7.8279E+06
x (M)	0.0000	9.9000	5.7000	0.0000	0.0000	7.8000	4.2000	10.800	0.0000	0.0000	0.0000
9	1.8100E-03	3.8850E-05	545.50	786.23	387.82	122.69	156.28	41.095	4580.7	7.8279E+06	7.8279E+06
x (M)	0.0000	9.9000	5.7000	0.0000	0.0000	7.8000	4.2000	10.800	0.0000	0.0000	0.0000
Max.	1.8184E-03	4.4910E-05	578.66	857.24	427.76	135.86	180.16	42.786	6550.1	7.8279E+06	7.8279E+06
Pile N.	1	5	7	7	7	7	7	7	7	1	1

LOAD CASE : 7
CASE NAME : Load Case
LOAD TYPE : Special, SpREDUCTION FACTORS FOR CLOSELY-SPACED PILE GROUPS, COMBINED Y AND Z DIRECTIONS
ESTIMATED USING MOVEMENT IN THE DIRECTION OF PILE CAP DISPLACEMENTS

GROUP NO	P-FACTOR	Y-FACTOR
1	0.8408	1.0000
2	0.7845	1.0000
3	0.8661	1.0000
4	0.5709	1.0000
5	0.4962	1.0000
6	0.6069	1.0000
7	0.5845	1.0000
8	0.5059	1.0000
9	0.6203	1.0000

APPALTATORE: Consorzio Soci   	ITINERARIO NAPOLI – BARI RADDOPPIO TRATTA APICE – ORSARA I LOTTO FUNZIONALE APICE – HIRPINIA
PROGETTAZIONE: Mandataria Mandanti   	
PROGETTO ESECUTIVO RELAZIONE DI CALCOLO FONDAZIONI PILE P1, P2, P21, P22, P23 E P24	COMMESSA IF28 LOTTO 01 CODIFICA E ZZ CL DOCUMENTO VI0403 002 REV. B FOGLIO 128 di 161

* TABLE L * COMPUTATION ON PILE CAP

* EQUIVALENT CONCENTRATED LOAD AT ORIGIN *

VERT. LOAD, KN 21530.0	HOR. LOAD Y, KN -3641.47	HOR. LOAD Z, KN 10471.2
MOMENT X, KN- M -362.000	MOMENT Y, KN- M 1.22170E+05	MOMENT Z, KN- M 35854.8

* DISPLACEMENT OF GROUPED PILE FOUNDATION AT ORIGIN *

VERTICAL, M 1.24187E-03	HORIZONTAL Y, M -2.69387E-03	HORIZONTAL Z, M 7.84813E-03
ANGLE ROT. X, RAD -2.65587E-05	ANGLE ROT. Y, RAD 6.27383E-04	ANGLE ROT. Z, RAD 2.05055E-04

THE GLOBAL STRUCTURAL COORDINATE SYSTEM

* PILE TOP DISPLACEMENTS *

PILE GROUP	DISP. X, M	DISP. Y, M	DISP. Z, M	ROT. X, RAD	ROT. Y, RAD	ROT. Z, RAD
*****	*****	*****	*****	*****	*****	*****
1	3.1423E-03	-2.5743E-03	7.7286E-03	-2.6559E-05	6.2738E-04	2.0505E-04
2	4.0651E-03	-2.5743E-03	7.8481E-03	-2.6559E-05	6.2738E-04	2.0505E-04
3	4.9878E-03	-2.5743E-03	7.9676E-03	-2.6559E-05	6.2738E-04	2.0505E-04
4	3.1913E-04	-2.6939E-03	7.7286E-03	-2.6559E-05	6.2738E-04	2.0505E-04
5	1.2419E-03	-2.6939E-03	7.8481E-03	-2.6559E-05	6.2738E-04	2.0505E-04
6	2.1646E-03	-2.6939E-03	7.9676E-03	-2.6559E-05	6.2738E-04	2.0505E-04
7	-2.5041E-03	-2.8134E-03	7.7286E-03	-2.6559E-05	6.2738E-04	2.0505E-04
8	-1.5814E-03	-2.8134E-03	7.8481E-03	-2.6559E-05	6.2738E-04	2.0505E-04
9	-6.5861E-04	-2.8134E-03	7.9676E-03	-2.6559E-05	6.2738E-04	2.0505E-04
MINIMUM	-2.5041E-03	-2.8134E-03	7.7286E-03	-2.6559E-05	6.2738E-04	2.0505E-04
Pile N.	7	7	1	1	1	1
MAXIMUM	4.9878E-03	-2.5743E-03	7.9676E-03	-2.6559E-05	6.2738E-04	2.0505E-04
Pile N.	3	1	3	1	1	1

* PILE TOP REACTIONS *

PILE GROUP	FOR. X, KN	FOR. Y, KN	FOR. Z, KN	MOM X, KN- M	MOM Y, KN- M	MOM Z, KN- M
*****	*****	*****	*****	*****	*****	*****
1	6509.7	-454.53	1355.5	-9.3929	-3571.8	-1204.6
2	7885.0	-431.83	1314.8	-9.3929	-3521.1	-1157.7
3	9175.6	-457.30	1421.0	-9.3929	-3780.4	-1212.5
4	709.22	-377.21	1056.4	-9.3929	-2908.1	-1061.5
5	2651.1	-341.63	976.58	-9.3929	-2756.9	-981.36
6	4524.6	-386.88	1130.2	-9.3929	-3139.6	-1086.5
7	-5173.5	-407.02	1075.4	-9.3929	-2936.6	-1151.4
8	-3308.4	-368.08	992.03	-9.3929	-2777.8	-1063.7
9	-1443.3	-416.99	1149.3	-9.3929	-3167.5	-1177.1
MINIMUM	-5173.5	-457.30	976.58	-9.3929	-3780.4	-1212.5
Pile N.	7	3	5	1	3	3
MAXIMUM	9175.6	-341.63	1421.0	-9.3929	-2756.9	-981.36
Pile N.	3	5	3	1	5	5

THE PILE COORDINATE SYSTEM (LOCAL AXES)

* PILE TOP DISPLACEMENTS *

PILE GROUP	DISP. x, M	DISP. y, M	DISP. z, M	ROT. x, RAD	ROT. y, RAD	ROT. z, RAD
*****	*****	*****	*****	*****	*****	*****
1	3.1423E-03	-2.5743E-03	7.7286E-03	-2.6559E-05	6.2738E-04	2.0505E-04
2	4.0651E-03	-2.5743E-03	7.8481E-03	-2.6559E-05	6.2738E-04	2.0505E-04
3	4.9878E-03	-2.5743E-03	7.9676E-03	-2.6559E-05	6.2738E-04	2.0505E-04
4	3.1913E-04	-2.6939E-03	7.7286E-03	-2.6559E-05	6.2738E-04	2.0505E-04
5	1.2419E-03	-2.6939E-03	7.8481E-03	-2.6559E-05	6.2738E-04	2.0505E-04
6	2.1646E-03	-2.6939E-03	7.9676E-03	-2.6559E-05	6.2738E-04	2.0505E-04
7	-2.5041E-03	-2.8134E-03	7.7286E-03	-2.6559E-05	6.2738E-04	2.0505E-04
8	-1.5814E-03	-2.8134E-03	7.8481E-03	-2.6559E-05	6.2738E-04	2.0505E-04
9	-6.5861E-04	-2.8134E-03	7.9676E-03	-2.6559E-05	6.2738E-04	2.0505E-04
MINIMUM	-2.5041E-03	-2.8134E-03	7.7286E-03	-2.6559E-05	6.2738E-04	2.0505E-04
Pile N.	7	7	1	1	1	1
MAXIMUM	4.9878E-03	-2.5743E-03	7.9676E-03	-2.6559E-05	6.2738E-04	2.0505E-04
Pile N.	3	1	3	1	1	1

APPALTATORE:

Consorzio

Soci



ITINERARIO NAPOLI – BARI

PROGETTAZIONE:

Mandataria

Mandanti

RADDOPPIO TRATTA APICE – ORSARA
I LOTTO FUNZIONALE APICE – HIRPINIA

PROGETTO ESECUTIVO

RELAZIONE DI CALCOLO FONDAZIONI PILE P1, P2, P21, P22, P23
E P24

COMMESSA	LOTTO	CODIFICA	DOCUMENTO	REV.	FOGLIO
IF28	01	E ZZ CL	VI0403 002	B	129 di 161

* PILE TOP REACTIONS *

PILE GROUP	AXIAL, KN	LAT. y, KN	LAT. z, KN	MOM x, KN- M	MOM y, KN- M	MOM z, KN- M
1	6509.7	-454.53	1355.5	-9.3929	-3571.8	-1204.6
2	7885.0	-431.83	1314.8	-9.3929	-3521.1	-1157.7
3	9175.6	-457.30	1421.0	-9.3929	-3780.4	-1212.5
4	709.22	-377.21	1056.4	-9.3929	-2908.1	-1061.5
5	2651.1	-341.63	976.58	-9.3929	-2756.9	-981.36
6	4524.6	-386.88	1130.2	-9.3929	-3139.6	-1086.5
7	-5173.5	-407.02	1075.4	-9.3929	-2936.6	-1151.4
8	-3308.4	-368.08	992.03	-9.3929	-2777.8	-1063.7
9	-1443.3	-416.99	1149.3	-9.3929	-3167.5	-1177.1
MINIMUM	-5173.5	-457.30	976.58	-9.3929	-3780.4	-1212.5
Pile N.	7	3	5	1	3	3
MAXIMUM	9175.6	-341.63	1421.0	-9.3929	-2756.9	-981.36
Pile N.	3	5	3	1	5	5

* PILE GROUP STRESS, KN/ M**2

PILE GROUP	STRESS, KN/ M**2
1	1.5060E+04
2	1.5648E+04
3	1.7174E+04
4	9744.4
5	1.0332E+04
6	1.2587E+04
7	1.2447E+04
8	1.0850E+04
9	1.1015E+04
MINIMUM	9744.4
Pile N.	4
MAXIMUM	1.7174E+04
Pile N.	3

* EFFECTS FOR LATERALLY LOADED PILE *

* MINIMUM VALUES AND LOCATIONS *

PILE	DISPL. y-DIR	DISPL. z-DIR	MOMENT z-DIR	MOMENT y-DIR	SHEAR y-DIR	SHEAR z-DIR	SOIL REACT y-DIR	SOIL REACT z-DIR	TOTAL STRESS	FLEX. RIG. z-DIR	FLEX. RIG. y-DIR
*****	*****	*****	*****	*****	*****	*****	*****	*****	*****	*****	*****
1	-2.5744E-03	-1.8585E-04	-607.92	-3571.8	-454.68	-416.20	-141.93	-98.517	3683.8	7.8279E+06	7.8279E+06
x(M)	0.0000	11.100	6.3000	0.0000	0.0000	9.0000	4.2000	10.800	30.000	0.0000	0.0000
2	-2.5744E-03	-1.8958E-04	-588.06	-3521.1	-432.00	-404.18	-132.66	-91.605	4462.0	7.8279E+06	7.8279E+06
x(M)	0.0000	11.100	6.3000	0.0000	0.0000	9.0000	4.2000	10.800	30.000	0.0000	0.0000
3	-2.5744E-03	-1.9103E-04	-611.53	-3780.4	-457.51	-435.38	-143.49	-103.21	5192.3	7.8279E+06	7.8279E+06
x(M)	0.0000	11.100	6.3000	0.0000	0.0000	8.7000	4.2000	10.800	30.000	0.0000	0.0000
4	-2.6939E-03	-1.8328E-04	-537.05	-2908.1	-377.22	-318.03	-106.66	-63.277	401.34	7.8279E+06	7.8279E+06
x(M)	0.0000	11.700	6.6000	0.0000	0.0000	9.6000	4.2000	16.200	30.000	0.0000	0.0000
5	-2.6939E-03	-1.8265E-04	-504.24	-2756.9	-341.68	-293.09	-93.444	-63.114	1500.2	7.8279E+06	7.8279E+06
x(M)	0.0000	12.000	6.9000	0.0000	0.0000	9.9000	4.2000	16.200	30.000	0.0000	0.0000
6	-2.6939E-03	-1.8977E-04	-548.42	-3139.6	-386.97	-339.74	-110.92	-65.357	2560.4	7.8279E+06	7.8279E+06
x(M)	0.0000	11.700	6.6000	0.0000	0.0000	9.6000	4.2000	16.200	30.000	0.0000	0.0000
7	-2.8134E-03	-1.8191E-04	-565.76	-2936.6	-406.91	-320.35	-114.53	-63.310	2927.6	7.8279E+06	7.8279E+06
x(M)	0.0000	11.700	6.6000	0.0000	0.0000	9.6000	4.2000	16.200	30.000	0.0000	0.0000
8	-2.8134E-03	-1.8117E-04	-530.20	-2777.8	-368.01	-294.26	-100.01	-63.220	1872.2	7.8279E+06	7.8279E+06
x(M)	0.0000	12.000	6.9000	0.0000	0.0000	9.9000	4.2000	16.200	30.000	0.0000	0.0000
9	-2.8134E-03	-1.8826E-04	-577.42	-3167.5	-416.96	-342.16	-118.92	-65.950	816.74	7.8279E+06	7.8279E+06
x(M)	0.0000	11.700	6.6000	0.0000	0.0000	9.3000	4.2000	10.800	30.000	0.0000	0.0000
Min.	-2.8134E-03	-1.9103E-04	-611.53	-3780.4	-457.51	-435.38	-143.49	-103.21	401.34	7.8279E+06	7.8279E+06
Pile N.	7	3	3	3	3	3	3	3	4	1	1

* MAXIMUM VALUES AND LOCATIONS *

PILE	DISPL. y-DIR	DISPL. z-DIR	MOMENT z-DIR	MOMENT y-DIR	SHEAR y-DIR	SHEAR z-DIR	SOIL REACT y-DIR	SOIL REACT z-DIR	TOTAL STRESS	FLEX. RIG. z-DIR	FLEX. RIG. y-DIR
*****	*****	*****	*****	*****	*****	*****	*****	*****	*****	*****	*****
1	6.2074E-05	7.7286E-03	1204.6	1822.9	138.99	1356.0	32.889	424.29	1.5060E+04	7.8279E+06	7.8279E+06
x(M)	11.100	0.0000	6.3000	0.0000	0.0000	9.0000	0.0000	10.800	4.2000	0.0000	0.0000
2	6.2215E-05	7.8481E-03	1157.7	1792.4	132.63	1315.3	30.059	404.11	1.5648E+04	7.8279E+06	7.8279E+06
x(M)	11.100	0.0000	0.0000	6.3000	9.0000	0.0000	10.800	4.2000	0.0000	0.0000	0.0000
3	6.1621E-05	7.9676E-03	1212.5	1894.0	140.54	1421.6	33.302	445.24	1.7174E+04	7.8279E+06	7.8279E+06
x(M)	11.100	0.0000	0.0000	6.3000	8.7000	0.0000	10.800	4.2000	0.0000	0.0000	0.0000
4	6.4327E-05	7.7286E-03	1061.5	1536.7	111.77	1056.4	22.519	301.61	9744.4	7.8279E+06	7.8279E+06
x(M)	11.700	0.0000	0.0000	6.6000	9.6000	0.0000	16.200	4.2000	0.0000	0.0000	0.0000
5	6.2992E-05	7.8481E-03	981.36	1465.3	101.27	976.72	21.993	269.23	1.0332E+04	7.8279E+06	7.8279E+06
x(M)	12.000	0.0000	0.0000	6.9000	9.9000	0.0000	16.200	4.2000	0.0000	0.0000	0.0000
6	6.4418E-05	7.9676E-03	1086.5	1619.5	115.40	1130.5	22.341	325.62	1.2587E+04	7.8279E+06	7.8279E+06
x(M)	11.700	0.0000	0.0000	6.6000	9.6000	0.0000	16.200	4.2000	0.0000	0.0000	0.0000
7	6.7004E-05	7.7286E-03	1151.4	1547.0	118.23	1075.1	23.844	307.28	1.2447E+04	7.8279E+06	7.8279E+06
x(M)	11.700	0.0000	0.0000	6.6000	9.6000	0.0000	16.200	4.2000	0.0000	0.0000	0.0000
8	6.5533E-05	7.8481E-03	1063.7	1471.9	106.79	991.85	23.300	273.36	1.0850E+04	7.8279E+06	7.8279E+06

APPALTATORE: Consorzio Soci   	ITINERARIO NAPOLI – BARI RADDOPPIO TRATTA APICE – ORSARA I LOTTO FUNZIONALE APICE – HIRPINIA
PROGETTAZIONE: Mandataria Mandanti   	
PROGETTO ESECUTIVO RELAZIONE DI CALCOLO FONDAZIONI PILE P1, P2, P21, P22, P23 E P24	
	COMMESSA IF28 LOTTO 01 CODIFICA E ZZ CL DOCUMENTO VI0403 002 REV. B FOGLIO 130 di 161

x(M)	12.000	0.0000	0.0000	6.9000	9.9000	0.0000	16.200	4.2000	0.0000	0.0000	0.0000
9	6.7085E-05	7.9676E-03	1177.1	1629.3	121.97	1149.2	23.613	331.26	1.1015E+04	7.8279E+06	7.8279E+06
x(M)	11.700	0.0000	0.0000	6.6000	9.6000	0.0000	16.200	4.2000	0.0000	0.0000	0.0000
Max. Pile N.	6.7085E-05	7.9676E-03	1212.5	1894.0	140.54	1421.6	33.302	445.24	1.7174E+04	7.8279E+06	7.8279E+06
	9	3	3	3	3	3	3	3	3	1	1

LOAD CASE : 8
CASE NAME : Load Case
LOAD TYPE : Special, Sp

REDUCTION FACTORS FOR CLOSELY-SPACED PILE GROUPS, COMBINED Y AND Z DIRECTIONS
ESTIMATED USING MOVEMENT IN THE DIRECTION OF PILE CAP DISPLACEMENTS

GROUP NO	P-FACTOR	Y-FACTOR
1	0.6269	1.0000
2	0.5077	1.0000
3	0.5845	1.0000
4	0.6121	1.0000
5	0.4962	1.0000
6	0.5694	1.0000
7	0.8661	1.0000
8	0.7805	1.0000
9	0.8359	1.0000

* TABLE L * COMPUTATION ON PILE CAP

* EQUIVALENT CONCENTRATED LOAD AT ORIGIN *

VERT. LOAD, KN	HOR. LOAD Y, KN	HOR. LOAD Z, KN
30430.0	4052.27	-10547.2
MOMENT X, KN- M	MOMENT Y, KN- M	MOMENT Z, KN- M
362.000	-1.20285E+05	-40696.8

* DISPLACEMENT OF GROUPED PILE FOUNDATION AT ORIGIN *

VERTICAL, M	HORIZONTAL Y, M	HORIZONTAL Z, M
1.78274E-03	3.03710E-03	-8.00705E-03
ANGLE ROT. X, RAD	ANGLE ROT. Y, RAD	ANGLE ROT. Z, RAD
-1.15942E-05	-6.43218E-04	-2.34452E-04

THE GLOBAL STRUCTURAL COORDINATE SYSTEM

* PILE TOP DISPLACEMENTS *

PILE GROUP	DISP. X, M	DISP. Y, M	DISP. Z, M	ROT. X, RAD	ROT. Y, RAD	ROT. Z, RAD
1	-5.6708E-05	3.0893E-03	-8.0592E-03	-1.1594E-05	-6.4322E-04	-2.3445E-04
2	-1.1117E-03	3.0893E-03	-8.0070E-03	-1.1594E-05	-6.4322E-04	-2.3445E-04
3	-2.1668E-03	3.0893E-03	-7.9549E-03	-1.1594E-05	-6.4322E-04	-2.3445E-04
4	2.8378E-03	3.0371E-03	-8.0592E-03	-1.1594E-05	-6.4322E-04	-2.3445E-04
5	1.7827E-03	3.0371E-03	-8.0070E-03	-1.1594E-05	-6.4322E-04	-2.3445E-04
6	7.2771E-04	3.0371E-03	-7.9549E-03	-1.1594E-05	-6.4322E-04	-2.3445E-04
7	5.7323E-03	2.9849E-03	-8.0592E-03	-1.1594E-05	-6.4322E-04	-2.3445E-04
8	4.6772E-03	2.9849E-03	-8.0070E-03	-1.1594E-05	-6.4322E-04	-2.3445E-04
9	3.6222E-03	2.9849E-03	-7.9549E-03	-1.1594E-05	-6.4322E-04	-2.3445E-04
MINIMUM Pile N.	-2.1668E-03	2.9849E-03	-8.0592E-03	-1.1594E-05	-6.4322E-04	-2.3445E-04
	3	7	1	1	1	1
MAXIMUM Pile N.	5.7323E-03	3.0893E-03	-7.9549E-03	-1.1594E-05	-6.4322E-04	-2.3445E-04
	7	1	3	1	1	1

* PILE TOP REACTIONS *

PILE GROUP	FOR. X, KN	FOR. Y, KN	FOR. Z, KN	MOM X, KN- M	MOM Y, KN- M	MOM Z, KN- M
1	-124.54	451.46	-1156.3	-4.1005	3177.1	1260.9
2	-2359.2	395.15	-1002.0	-4.1005	2807.9	1130.2
3	-4491.7	434.93	-1093.8	-4.1005	3001.0	1219.4
4	5891.3	432.75	-1134.2	-4.1005	3142.6	1212.4
5	3749.2	378.67	-982.77	-4.1005	2778.9	1086.4
6	1607.1	416.15	-1070.9	-4.1005	2964.5	1170.7
7	1.0151E+04	528.08	-1418.0	-4.1005	3768.4	1410.0
8	8741.1	495.45	-1318.4	-4.1005	3540.2	1339.5
9	7265.5	519.62	-1370.8	-4.1005	3633.8	1389.5

APPALDATTORE: Consorzio  Soci  		ITINERARIO NAPOLI – BARI RADDOPPIO TRATTA APICE – ORSARA I LOTTO FUNZIONALE APICE – HIRPINIA					
PROGETTAZIONE: Mandatario  Mandanti  							
PROGETTO ESECUTIVO RELAZIONE DI CALCOLO FONDAZIONI PILE P1, P2, P21, P22, P23 E P24							COMMESSA IF28

MINIMUM	-4491.7	378.67	-1418.0	-4.1005	2778.9	1086.4
Pile N.	3	5	7	1	5	5
MAXIMUM	1.0151E+04	528.08	-982.77	-4.1005	3768.4	1410.0
Pile N.	7	7	5	1	7	7

THE PILE COORDINATE SYSTEM (LOCAL AXES)

* PILE TOP DISPLACEMENTS *

PILE GROUP	DISP. x, M	DISP. y, M	DISP. z, M	ROT. x,RAD	ROT. y,RAD	ROT. z,RAD
*****	*****	*****	*****	*****	*****	*****
1	-5.6708E-05	3.0893E-03	-8.0592E-03	-1.1594E-05	-6.4322E-04	-2.3445E-04
2	-1.1117E-03	3.0893E-03	-8.0070E-03	-1.1594E-05	-6.4322E-04	-2.3445E-04
3	-2.1668E-03	3.0893E-03	-7.9549E-03	-1.1594E-05	-6.4322E-04	-2.3445E-04
4	2.8378E-03	3.0371E-03	-8.0592E-03	-1.1594E-05	-6.4322E-04	-2.3445E-04
5	1.7827E-03	3.0371E-03	-8.0070E-03	-1.1594E-05	-6.4322E-04	-2.3445E-04
6	7.2771E-04	3.0371E-03	-7.9549E-03	-1.1594E-05	-6.4322E-04	-2.3445E-04
7	5.7323E-03	2.9849E-03	-8.0592E-03	-1.1594E-05	-6.4322E-04	-2.3445E-04
8	4.6772E-03	2.9849E-03	-8.0070E-03	-1.1594E-05	-6.4322E-04	-2.3445E-04
9	3.6222E-03	2.9849E-03	-7.9549E-03	-1.1594E-05	-6.4322E-04	-2.3445E-04
MINIMUM	-2.1668E-03	2.9849E-03	-8.0592E-03	-1.1594E-05	-6.4322E-04	-2.3445E-04
Pile N.	3	7	1	1	1	1
MAXIMUM	5.7323E-03	3.0893E-03	-7.9549E-03	-1.1594E-05	-6.4322E-04	-2.3445E-04
Pile N.	7	1	3	1	1	1

* PILE TOP REACTIONS *

PILE GROUP	AXIAL, KN	LAT. y, KN	LAT. z, KN	MOM x, KN- M	MOM y, KN- M	MOM z, KN- M
*****	*****	*****	*****	*****	*****	*****
1	-124.54	451.46	-1156.3	-4.1005	3177.1	1260.9
2	-2359.2	395.15	-1002.0	-4.1005	2807.9	1130.2
3	-4491.7	434.93	-1093.8	-4.1005	3001.0	1219.4
4	5891.3	432.75	-1134.2	-4.1005	3142.6	1212.4
5	3749.2	378.67	-982.77	-4.1005	2778.9	1086.4
6	1607.1	416.15	-1070.9	-4.1005	2964.5	1170.7
7	1.0151E+04	528.08	-1418.0	-4.1005	3768.4	1410.0
8	8741.1	495.45	-1318.4	-4.1005	3540.2	1339.5
9	7265.5	519.62	-1370.8	-4.1005	3633.8	1389.5
MINIMUM	-4491.7	378.67	-1418.0	-4.1005	2778.9	1086.4
Pile N.	3	5	7	1	5	5
MAXIMUM	1.0151E+04	528.08	-982.77	-4.1005	3768.4	1410.0
Pile N.	7	7	5	1	7	7

PILE GROUP	STRESS, KN/ M**2
*****	*****
1	1.0387E+04
2	1.0470E+04
3	1.2318E+04
4	1.3500E+04
5	1.1126E+04
6	1.0529E+04
7	1.7888E+04
8	1.6370E+04
9	1.5853E+04
MINIMUM	1.0387E+04
Pile N.	1
MAXIMUM	1.7888E+04
Pile N.	7

* EFFECTS FOR LATERALLY LOADED PILE *

* MINIMUM VALUES AND LOCATIONS *

PILE	DISPL. y-DIR	DISPL. z-DIR	MOMENT y-DIR	MOMENT z-DIR	SHEAR y-DIR	SHEAR z-DIR	SOIL REACT y-DIR	SOIL REACT z-DIR	TOTAL STRESS	FLEX. RIG. z-DIR	FLEX. RIG. y-DIR
*****	*****	*****	*****	*****	*****	*****	*****	*****	*****	*****	*****
	M	M	KN- M	KN- M	KN	KN	KN/ M	KN/ M	KN/ M**2	KN- M**2	KN- M**2
1	-7.3373E-05	-8.0592E-03	-1260.9	-1650.0	-133.92	-1156.3	-25.675	-334.52	70.477	7.8279E+06	7.8279E+06
x(M)	11.700	0.0000	6.6000	6.6000	9.3000	0.0000	10.800	4.2000	30.000	0.0000	0.0000
2	-7.1277E-05	-8.0071E-03	-1130.2	-1496.2	-116.26	-1001.8	-25.077	-276.08	1335.0	7.8279E+06	7.8279E+06
x(M)	12.000	0.0000	0.0000	6.9000	9.9000	0.0000	16.200	4.2000	30.000	0.0000	0.0000
3	-7.2515E-05	-7.9549E-03	-1219.4	-1580.5	-127.91	-1093.5	-25.549	-311.45	2541.8	7.8279E+06	7.8279E+06
x(M)	11.700	0.0000	0.0000	6.6000	9.6000	0.0000	16.200	4.2000	30.000	0.0000	0.0000
4	-7.2404E-05	-8.0592E-03	-1212.4	-1637.4	-130.09	-1134.5	-24.937	-327.78	3333.8	7.8279E+06	7.8279E+06
x(M)	11.700	0.0000	0.0000	6.6000	9.6000	0.0000	16.200	4.2000	30.000	0.0000	0.0000
5	-7.0400E-05	-8.0071E-03	-1086.4	-1486.2	-113.26	-982.97	-24.444	-270.66	2121.6	7.8279E+06	7.8279E+06
x(M)	12.000	0.0000	0.0000	6.9000	9.9000	0.0000	16.200	4.2000	30.000	0.0000	0.0000
6	-7.1515E-05	-7.9549E-03	-1170.7	-1566.6	-124.17	-1071.0	-24.932	-304.49	909.44	7.8279E+06	7.8279E+06
x(M)	11.700	0.0000	0.0000	6.6000	9.6000	0.0000	16.200	4.2000	30.000	0.0000	0.0000
7	-7.1560E-05	-8.0592E-03	-1410.0	-1906.0	-162.16	-1418.7	-38.120	-444.39	5744.3	7.8279E+06	7.8279E+06
x(M)	11.100	0.0000	0.0000	6.3000	9.0000	0.0000	10.800	4.2000	30.000	0.0000	0.0000
8	-7.1956E-05	-8.0071E-03	-1339.5	-1811.9	-152.18	-1319.0	-33.950	-404.01	4946.5	7.8279E+06	7.8279E+06

APPALTATORE:

Consorzio

Soci



ITINERARIO NAPOLI – BARI

PROGETTAZIONE:

Mandataria

Mandanti



RADDOPPIO TRATTA APICE – ORSARA
I LOTTO FUNZIONALE APICE – HIRPINIA

PROGETTO ESECUTIVO

RELAZIONE DI CALCOLO FONDAZIONI PILE P1, P2, P21, P22, P23
E P24

COMMESSA IF28	LOTTO 01	CODIFICA E ZZ CL	DOCUMENTO VI0403 002	REV. B	FOGLIO 133 di 161
------------------	-------------	---------------------	-------------------------	-----------	-------------------------

1	3.1814E-03	7.8104E-03	-2.0135E-03	1.3381E-05	-1.6815E-04	-5.7650E-04
2	5.8718E-04	7.8104E-03	-2.0738E-03	1.3381E-05	-1.6815E-04	-5.7650E-04
3	-2.0071E-03	7.8104E-03	-2.1340E-03	1.3381E-05	-1.6815E-04	-5.7650E-04
4	3.9381E-03	7.8706E-03	-2.0135E-03	1.3381E-05	-1.6815E-04	-5.7650E-04
5	1.3438E-03	7.8706E-03	-2.0738E-03	1.3381E-05	-1.6815E-04	-5.7650E-04
6	-1.2504E-03	7.8706E-03	-2.1340E-03	1.3381E-05	-1.6815E-04	-5.7650E-04
7	4.6948E-03	7.9309E-03	-2.0135E-03	1.3381E-05	-1.6815E-04	-5.7650E-04
8	2.1005E-03	7.9309E-03	-2.0738E-03	1.3381E-05	-1.6815E-04	-5.7650E-04
9	-4.9372E-04	7.9309E-03	-2.1340E-03	1.3381E-05	-1.6815E-04	-5.7650E-04
MINIMUM	-2.0071E-03	7.8104E-03	-2.1340E-03	1.3381E-05	-1.6815E-04	-5.7650E-04
Pile N.	3	1	3	1	1	1
MAXIMUM	4.6948E-03	7.9309E-03	-2.0135E-03	1.3381E-05	-1.6815E-04	-5.7650E-04
Pile N.	7	7	1	1	1	1

* PILE TOP REACTIONS *

PILE GROUP	FOR. X, KN	FOR. Y, KN	FOR. Z, KN	MOM X, KN- M	MOM Y, KN- M	MOM Z, KN- M
1	6589.1	1421.3	-351.35	4.7323	915.85	3839.6
2	1304.9	1107.0	-283.96	4.7323	781.44	3142.5
3	-4168.9	1123.8	-299.97	4.7323	827.84	3167.2
4	7707.4	1367.4	-334.33	4.7323	880.75	3744.3
5	2858.1	1013.0	-256.78	4.7323	720.32	2943.8
6	-2639.4	1025.0	-270.49	4.7323	761.59	2958.2
7	8765.7	1456.5	-352.92	4.7323	920.51	3951.3
8	4394.4	1148.8	-288.74	4.7323	794.27	3272.4
9	-1084.3	1165.6	-304.86	4.7323	840.93	3296.9
MINIMUM	-4168.9	1013.0	-352.92	4.7323	720.32	2943.8
Pile N.	3	5	7	1	5	5
MAXIMUM	8765.7	1456.5	-256.78	4.7323	920.51	3951.3
Pile N.	7	7	5	1	7	7

THE PILE COORDINATE SYSTEM (LOCAL AXES)

* PILE TOP DISPLACEMENTS *

PILE GROUP	DISP. x, M	DISP. y, M	DISP. z, M	ROT. x, RAD	ROT. y, RAD	ROT. z, RAD
1	3.1814E-03	7.8104E-03	-2.0135E-03	1.3381E-05	-1.6815E-04	-5.7650E-04
2	5.8718E-04	7.8104E-03	-2.0738E-03	1.3381E-05	-1.6815E-04	-5.7650E-04
3	-2.0071E-03	7.8104E-03	-2.1340E-03	1.3381E-05	-1.6815E-04	-5.7650E-04
4	3.9381E-03	7.8706E-03	-2.0135E-03	1.3381E-05	-1.6815E-04	-5.7650E-04
5	1.3438E-03	7.8706E-03	-2.0738E-03	1.3381E-05	-1.6815E-04	-5.7650E-04
6	-1.2504E-03	7.8706E-03	-2.1340E-03	1.3381E-05	-1.6815E-04	-5.7650E-04
7	4.6948E-03	7.9309E-03	-2.0135E-03	1.3381E-05	-1.6815E-04	-5.7650E-04
8	2.1005E-03	7.9309E-03	-2.0738E-03	1.3381E-05	-1.6815E-04	-5.7650E-04
9	-4.9372E-04	7.9309E-03	-2.1340E-03	1.3381E-05	-1.6815E-04	-5.7650E-04
MINIMUM	-2.0071E-03	7.8104E-03	-2.1340E-03	1.3381E-05	-1.6815E-04	-5.7650E-04
Pile N.	3	1	3	1	1	1
MAXIMUM	4.6948E-03	7.9309E-03	-2.0135E-03	1.3381E-05	-1.6815E-04	-5.7650E-04
Pile N.	7	7	1	1	1	1

* PILE TOP REACTIONS *

PILE GROUP	AXIAL, KN	LAT. y, KN	LAT. z, KN	MOM x, KN- M	MOM y, KN- M	MOM z, KN- M
1	6589.1	1421.3	-351.35	4.7323	915.85	3839.6
2	1304.9	1107.0	-283.96	4.7323	781.44	3142.5
3	-4168.9	1123.8	-299.97	4.7323	827.84	3167.2
4	7707.4	1367.4	-334.33	4.7323	880.75	3744.3
5	2858.1	1013.0	-256.78	4.7323	720.32	2943.8
6	-2639.4	1025.0	-270.49	4.7323	761.59	2958.2
7	8765.7	1456.5	-352.92	4.7323	920.51	3951.3
8	4394.4	1148.8	-288.74	4.7323	794.27	3272.4
9	-1084.3	1165.6	-304.86	4.7323	840.93	3296.9
MINIMUM	-4168.9	1013.0	-352.92	4.7323	720.32	2943.8
Pile N.	3	5	7	1	5	5
MAXIMUM	8765.7	1456.5	-256.78	4.7323	920.51	3951.3
Pile N.	7	7	5	1	7	7

PILE GROUP STRESS, KN/ M**2

PILE GROUP	STRESS, KN/ M**2
1	1.5642E+04
2	1.0512E+04
3	1.2239E+04
4	1.5970E+04
5	1.0764E+04
6	1.0713E+04
7	1.7205E+04
8	1.2650E+04
9	1.0882E+04

APPALTATORE:

Consorzio

Soci



ITINERARIO NAPOLI – BARI

PROGETTAZIONE:

Mandataria

Mandanti



**RADDOPPIO TRATTA APICE – ORSARA
I LOTTO FUNZIONALE APICE – HIRPINIA**

PROGETTO ESECUTIVO

**RELAZIONE DI CALCOLO FONDAZIONI PILE P1, P2, P21, P22, P23
E P24**

COMMESSA	LOTTO	CODIFICA	DOCUMENTO	REV.	FOGLIO
IF28	01	E ZZ CL	VI0403 002	B	134 di 161

MINIMUM 1.0512E+04
Pile N. 2
MAXIMUM 1.7205E+04
Pile N. 7

* EFFECTS FOR Laterally Loaded Pile *

* MINIMUM VALUES AND LOCATIONS *

PILE	DISPL. y-DIR M	DISPL. z-DIR M	MOMENT z-DIR KN- M	MOMENT y-DIR KN- M	SHEAR y-DIR KN	SHEAR z-DIR KN	SOIL REACT y-DIR KN/ M	SOIL REACT z-DIR KN/ M	TOTAL STRESS KN/ M**2	FLEX. RIG. z-DIR KN- M**2	FLEX. RIG. y-DIR KN- M**2
*****	*****	*****	*****	*****	*****	*****	*****	*****	*****	*****	*****
1	-1.8831E-04	-2.0135E-03	-3839.6	-474.79	-426.32	-351.47	-101.18	-110.57	3728.7	7.8279E+06	7.8279E+06
x(M)	11.100	0.0000	0.0000	6.3000	9.0000	0.0000	10.800	4.2000	30.000	0.0000	0.0000
2	-1.8509E-04	-2.0738E-03	-3142.5	-412.05	-324.24	-283.98	-65.601	-81.184	738.44	7.8279E+06	7.8279E+06
x(M)	11.700	0.0000	0.0000	6.6000	9.6000	0.0000	16.200	4.2000	30.000	0.0000	0.0000
3	-1.8404E-04	-2.1340E-03	-3167.2	-426.84	-326.10	-299.90	-65.697	-85.399	2359.1	7.8279E+06	7.8279E+06
x(M)	11.700	0.0000	0.0000	6.6000	9.6000	0.0000	16.200	4.2000	30.000	0.0000	0.0000
4	-1.9057E-04	-2.0135E-03	-3744.3	-460.02	-410.62	-334.46	-93.645	-103.58	4361.5	7.8279E+06	7.8279E+06
x(M)	11.100	0.0000	0.0000	6.3000	9.0000	0.0000	10.800	4.2000	30.000	0.0000	0.0000
5	-1.8326E-04	-2.0738E-03	-2943.8	-386.34	-296.06	-256.82	-64.854	-71.014	1617.4	7.8279E+06	7.8279E+06
x(M)	12.000	0.0000	0.0000	6.9000	9.9000	0.0000	16.200	4.2000	30.000	0.0000	0.0000
6	-1.8202E-04	-2.1340E-03	-2958.2	-399.18	-296.49	-270.45	-64.962	-74.342	1493.6	7.8279E+06	7.8279E+06
x(M)	12.000	0.0000	0.0000	6.9000	9.9000	0.0000	16.200	4.2000	30.000	0.0000	0.0000
7	-1.9106E-04	-2.0135E-03	-3951.3	-476.92	-436.88	-353.07	-103.97	-111.45	4960.4	7.8279E+06	7.8279E+06
x(M)	11.100	0.0000	0.0000	6.3000	9.0000	0.0000	10.800	4.2000	30.000	0.0000	0.0000
8	-1.8920E-04	-2.0738E-03	-3272.4	-417.90	-337.50	-288.81	-66.722	-83.315	2486.7	7.8279E+06	7.8279E+06
x(M)	11.700	0.0000	0.0000	6.6000	9.6000	0.0000	16.200	4.2000	30.000	0.0000	0.0000
9	-1.8807E-04	-2.1340E-03	-3296.9	-432.80	-339.27	-304.84	-66.721	-87.584	613.60	7.8279E+06	7.8279E+06
x(M)	11.700	0.0000	0.0000	6.6000	9.6000	0.0000	16.200	4.2000	30.000	0.0000	0.0000
Min.	-1.9106E-04	-2.1340E-03	-3951.3	-476.92	-436.88	-353.07	-103.97	-111.45	613.60	7.8279E+06	7.8279E+06
Pile N.	7	3	7	7	7	7	7	7	9	1	1

* MAXIMUM VALUES AND LOCATIONS *

PILE	DISPL. y-DIR M	DISPL. z-DIR M	MOMENT z-DIR KN- M	MOMENT y-DIR KN- M	SHEAR y-DIR KN	SHEAR z-DIR KN	SOIL REACT y-DIR KN/ M	SOIL REACT z-DIR KN/ M	TOTAL STRESS KN/ M**2	FLEX. RIG. z-DIR KN- M**2	FLEX. RIG. y-DIR KN- M**2
*****	*****	*****	*****	*****	*****	*****	*****	*****	*****	*****	*****
1	7.8104E-03	4.7714E-05	1855.4	915.85	1421.8	108.31	440.59	25.718	1.5642E+04	7.8279E+06	7.8279E+06
x(M)	0.0000	11.100	6.3000	0.0000	0.0000	8.7000	4.2000	10.800	0.0000	0.0000	0.0000
2	7.8104E-03	4.8668E-05	1557.7	781.44	1107.1	85.117	312.19	16.905	1.0512E+04	7.8279E+06	7.8279E+06
x(M)	0.0000	11.700	6.6000	0.0000	0.0000	9.6000	4.2000	16.200	0.0000	0.0000	0.0000
3	7.8104E-03	4.9938E-05	1566.5	827.84	1123.6	88.392	317.03	17.586	1.2239E+04	7.8279E+06	7.8279E+06
x(M)	0.0000	11.700	6.6000	0.0000	0.0000	9.6000	4.2000	16.200	0.0000	0.0000	0.0000
4	7.8706E-03	4.7953E-05	1810.3	880.75	1367.9	103.53	416.66	23.653	1.5970E+04	7.8279E+06	7.8279E+06
x(M)	0.0000	11.100	6.3000	0.0000	0.0000	9.0000	4.2000	10.800	0.0000	0.0000	0.0000
5	7.8706E-03	4.7827E-05	1473.8	720.32	1013.2	76.985	275.71	16.569	1.0764E+04	7.8279E+06	7.8279E+06
x(M)	0.0000	12.000	6.9000	0.0000	0.0000	9.9000	4.2000	16.200	0.0000	0.0000	0.0000
6	7.8706E-03	4.9011E-05	1477.7	761.59	1024.8	79.638	278.61	17.234	1.0713E+04	7.8279E+06	7.8279E+06
x(M)	0.0000	12.000	6.9000	0.0000	0.0000	9.9000	4.2000	16.200	0.0000	0.0000	0.0000
7	7.9309E-03	4.7568E-05	1894.4	920.51	1457.1	109.36	452.35	25.973	1.7205E+04	7.8279E+06	7.8279E+06
x(M)	0.0000	11.100	6.3000	0.0000	0.0000	8.7000	4.2000	10.800	0.0000	0.0000	0.0000
8	7.9309E-03	4.8867E-05	1605.9	794.27	1149.1	87.010	326.34	16.847	1.2650E+04	7.8279E+06	7.8279E+06
x(M)	0.0000	11.700	6.6000	0.0000	0.0000	9.6000	4.2000	16.200	0.0000	0.0000	0.0000
9	7.9309E-03	5.0141E-05	1614.4	840.93	1165.5	90.337	331.18	17.503	1.0882E+04	7.8279E+06	7.8279E+06
x(M)	0.0000	11.700	6.6000	0.0000	0.0000	9.6000	4.2000	16.200	0.0000	0.0000	0.0000
Max.	7.9309E-03	5.0141E-05	1894.4	920.51	1457.1	109.36	452.35	25.973	1.7205E+04	7.8279E+06	7.8279E+06
Pile N.	7	9	7	7	7	7	7	7	7	1	1

LOAD CASE : 10
CASE NAME : Load Case
LOAD TYPE : Special, Sp

REDUCTION FACTORS FOR CLOSELY-SPACED PILE GROUPS, COMBINED Y AND Z DIRECTIONS ESTIMATED USING MOVEMENT IN THE DIRECTION OF PILE CAP DISPLACEMENTS

GROUP NO	P-FACTOR	Y-FACTOR
1	0.6092	1.0000
2	0.5982	1.0000
3	0.8661	1.0000
4	0.5030	1.0000
5	0.4962	1.0000
6	0.7912	1.0000
7	0.5845	1.0000
8	0.5735	1.0000
9	0.8489	1.0000

* TABLE L * COMPUTATION ON PILE CAP

APPALTATORE: Consorzio  Soci  	ITINERARIO NAPOLI – BARI RADDOPPIO TRATTA APICE – ORSARA I LOTTO FUNZIONALE APICE – HIRPINIA				
PROGETTAZIONE: Mandataria  Mandanti  					
PROGETTO ESECUTIVO RELAZIONE DI CALCOLO FONDAZIONI PILE P1, P2, P21, P22, P23 E P24	COMMESSA IF28	LOTTO 01	CODIFICA E ZZ CL	DOCUMENTO VI0403 002	REV. B FOGLIO 135 di 161

* EQUIVALENT CONCENTRATED LOAD AT ORIGIN *

VERT. LOAD, KN 29884.0	HOR. LOAD Y, KN -10137.6	HOR. LOAD Z, KN 2693.90
MOMENT X, KN- M 109.000	MOMENT Y, KN- M 30734.5	MOMENT Z, KN- M 1.00646E+05

* DISPLACEMENT OF GROUPED PILE FOUNDATION AT ORIGIN *

VERTICAL, M 1.69145E-03	HORIZONTAL Y, M -7.21107E-03	HORIZONTAL Z, M 2.00934E-03
ANGLE ROT. X, RAD 1.77499E-05	ANGLE ROT. Y, RAD 1.69349E-04	ANGLE ROT. Z, RAD 5.40137E-04

THE GLOBAL STRUCTURAL COORDINATE SYSTEM

* PILE TOP DISPLACEMENTS *

PILE GROUP	DISP. X, M	DISP. Y, M	DISP. Z, M	ROT. X, RAD	ROT. Y, RAD	ROT. Z, RAD
*****	*****	*****	*****	*****	*****	*****
1	2.2909E-05	-7.2909E-03	2.0892E-03	1.7750E-05	1.6935E-04	5.4014E-04
2	2.4535E-03	-7.2909E-03	2.0093E-03	1.7750E-05	1.6935E-04	5.4014E-04
3	4.8841E-03	-7.2909E-03	1.9295E-03	1.7750E-05	1.6935E-04	5.4014E-04
4	-7.3916E-04	-7.2111E-03	2.0892E-03	1.7750E-05	1.6935E-04	5.4014E-04
5	1.6914E-03	-7.2111E-03	2.0093E-03	1.7750E-05	1.6935E-04	5.4014E-04
6	4.1221E-03	-7.2111E-03	1.9295E-03	1.7750E-05	1.6935E-04	5.4014E-04
7	-1.5012E-03	-7.1312E-03	2.0892E-03	1.7750E-05	1.6935E-04	5.4014E-04
8	9.2938E-04	-7.1312E-03	2.0093E-03	1.7750E-05	1.6935E-04	5.4014E-04
9	3.3600E-03	-7.1312E-03	1.9295E-03	1.7750E-05	1.6935E-04	5.4014E-04
MINIMUM	-1.5012E-03	-7.2909E-03	1.9295E-03	1.7750E-05	1.6935E-04	5.4014E-04
Pile N.	7	1	3	1	1	1
MAXIMUM	4.8841E-03	-7.1312E-03	2.0892E-03	1.7750E-05	1.6935E-04	5.4014E-04
Pile N.	3	7	1	1	1	1

* PILE TOP REACTIONS *

PILE GROUP	FOR. X, KN	FOR. Y, KN	FOR. Z, KN	MOM X, KN- M	MOM Y, KN- M	MOM Z, KN- M
*****	*****	*****	*****	*****	*****	*****
1	50.913	-1097.0	304.35	6.2775	-827.15	-3068.5
2	5111.2	-1081.4	284.06	6.2775	-766.29	-3045.2
3	9030.5	-1368.4	341.35	6.2775	-870.32	-3670.6
4	-1606.1	-959.59	269.82	6.2775	-748.21	-2735.5
5	3563.9	-948.27	252.28	6.2775	-693.52	-2721.1
6	7964.7	-1279.0	323.32	6.2775	-832.24	-3459.7
7	-3146.5	-1047.6	299.39	6.2775	-814.11	-2913.7
8	2016.6	-1032.0	279.23	6.2775	-753.61	-2890.2
9	6898.8	-1324.3	340.10	6.2775	-866.51	-3530.5
MINIMUM	-3146.5	-1368.4	252.28	6.2775	-870.32	-3670.6
Pile N.	7	3	5	1	3	3
MAXIMUM	9030.5	-948.27	341.35	6.2775	-693.52	-2721.1
Pile N.	3	5	3	1	5	5

THE PILE COORDINATE SYSTEM (LOCAL AXES)

* PILE TOP DISPLACEMENTS *

PILE GROUP	DISP. x, M	DISP. y, M	DISP. z, M	ROT. x, RAD	ROT. y, RAD	ROT. z, RAD
*****	*****	*****	*****	*****	*****	*****
1	2.2909E-05	-7.2909E-03	2.0892E-03	1.7750E-05	1.6935E-04	5.4014E-04
2	2.4535E-03	-7.2909E-03	2.0093E-03	1.7750E-05	1.6935E-04	5.4014E-04
3	4.8841E-03	-7.2909E-03	1.9295E-03	1.7750E-05	1.6935E-04	5.4014E-04
4	-7.3916E-04	-7.2111E-03	2.0892E-03	1.7750E-05	1.6935E-04	5.4014E-04
5	1.6914E-03	-7.2111E-03	2.0093E-03	1.7750E-05	1.6935E-04	5.4014E-04
6	4.1221E-03	-7.2111E-03	1.9295E-03	1.7750E-05	1.6935E-04	5.4014E-04
7	-1.5012E-03	-7.1312E-03	2.0892E-03	1.7750E-05	1.6935E-04	5.4014E-04
8	9.2938E-04	-7.1312E-03	2.0093E-03	1.7750E-05	1.6935E-04	5.4014E-04
9	3.3600E-03	-7.1312E-03	1.9295E-03	1.7750E-05	1.6935E-04	5.4014E-04
MINIMUM	-1.5012E-03	-7.2909E-03	1.9295E-03	1.7750E-05	1.6935E-04	5.4014E-04
Pile N.	7	1	3	1	1	1
MAXIMUM	4.8841E-03	-7.1312E-03	2.0892E-03	1.7750E-05	1.6935E-04	5.4014E-04
Pile N.	3	7	1	1	1	1

* PILE TOP REACTIONS *

PILE GROUP	AXIAL, KN	LAT. y, KN	LAT. z, KN	MOM x, KN- M	MOM y, KN- M	MOM z, KN- M
------------	-----------	------------	------------	--------------	--------------	--------------

APPALDATTORE:

Consorzio

Soci



ITINERARIO NAPOLI – BARI

PROGETTAZIONE:

Mandatario

Mandanti

RADDOPPIO TRATTA APICE – ORSARA
I LOTTO FUNZIONALE APICE – HIRPINIA

PROGETTO ESECUTIVO

RELAZIONE DI CALCOLO FONDAZIONI PILE P1, P2, P21, P22, P23
E P24COMMESSA
IF28LOTTO
01CODIFICA
E ZZ CLDOCUMENTO
VI0403 002REV.
BFOGLIO
136 di
161

	*****	*****	*****	*****	*****	*****	*****
1	50.913	-1097.0	304.35	6.2775	-827.15	-3068.5	
2	5111.2	-1081.4	284.06	6.2775	-766.29	-3045.2	
3	9030.5	-1368.4	341.35	6.2775	-870.32	-3670.6	
4	-1606.1	-959.59	269.82	6.2775	-748.21	-2735.5	
5	3563.9	-948.27	252.28	6.2775	-693.52	-2721.1	
6	7964.7	-1279.0	323.32	6.2775	-832.24	-3459.7	
7	-3146.5	-1047.6	299.39	6.2775	-814.11	-2913.7	
8	2016.6	-1032.0	279.23	6.2775	-753.61	-2890.2	
9	6898.8	-1324.3	340.10	6.2775	-866.51	-3530.5	
MINIMUM	-3146.5	-1368.4	252.28	6.2775	-870.32	-3670.6	
Pile N.	7	3	3	1	3	3	
MAXIMUM	9030.5	-948.27	341.35	6.2775	-693.52	-2721.1	
Pile N.	3	5	3	1	5	5	

PILE GROUP STRESS, KN/ M**2

*****	*****
1	9620.2
2	1.2369E+04
3	1.6495E+04
4	9468.0
5	1.0492E+04
6	1.5246E+04
7	1.0911E+04
8	1.0156E+04
9	1.4875E+04
MINIMUM	9468.0
Pile N.	4
MAXIMUM	1.6495E+04
Pile N.	3

* EFFECTS FOR laterally loaded PILE *

* MINIMUM VALUES AND LOCATIONS *

PILE	DISPL.	DISPL.	MOMENT	MOMENT	SHEAR	SHEAR	SOIL REACT	SOIL REACT	TOTAL	FLEX. RIG.	FLEX. RIG.
	y-DIR	z-DIR	z-DIR	y-DIR	y-DIR	z-DIR	y-DIR	z-DIR	STRESS	z-DIR	y-DIR
	M	M	KN- M	KN- M	KN	KN	KN/ M	KN/ M	KN/ M**2	KN- M**2	KN- M**2
*****	*****	*****	*****	*****	*****	*****	*****	*****	*****	*****	*****
1	-7.2909E-03	-5.0131E-05	-1513.8	-827.15	-1097.0	-91.256	-315.68	-18.316	28.811	7.8279E+06	7.8279E+06
x (M)	0.0000	11.700	6.6000	0.0000	0.0000	9.3000	4.2000	10.800	30.000	0.0000	0.0000
2	-7.2909E-03	-4.8327E-05	-1505.7	-766.29	-1081.7	-86.881	-311.01	-17.315	2892.3	7.8279E+06	7.8279E+06
x (M)	0.0000	11.700	6.6000	0.0000	0.0000	9.3000	4.2000	10.800	30.000	0.0000	0.0000
3	-7.2909E-03	-4.5908E-05	-1770.9	-870.32	-1369.0	-107.84	-429.84	-26.112	5110.2	7.8279E+06	7.8279E+06
x (M)	0.0000	10.800	6.3000	0.0000	0.0000	8.7000	4.2000	10.800	30.000	0.0000	0.0000
4	-7.2111E-03	-4.9321E-05	-1379.1	-748.21	-959.51	-79.955	-264.36	-17.225	908.88	7.8279E+06	7.8279E+06
x (M)	0.0000	12.000	6.9000	0.0000	0.0000	9.6000	4.2000	16.200	30.000	0.0000	0.0000
5	-7.2111E-03	-4.7570E-05	-1375.0	-693.52	-948.45	-76.418	-261.47	-16.341	2016.7	7.8279E+06	7.8279E+06
x (M)	0.0000	12.000	6.9000	0.0000	0.0000	9.6000	4.2000	16.200	30.000	0.0000	0.0000
6	-7.2111E-03	-4.6324E-05	-1688.0	-832.24	-1279.6	-100.95	-394.46	-23.847	4507.1	7.8279E+06	7.8279E+06
x (M)	0.0000	11.100	6.3000	0.0000	0.0000	9.0000	4.2000	10.800	30.000	0.0000	0.0000
7	-7.1312E-03	-5.0240E-05	-1458.9	-814.11	-1047.5	-88.915	-299.63	-17.548	1780.5	7.8279E+06	7.8279E+06
x (M)	0.0000	11.700	6.6000	0.0000	0.0000	9.3000	4.2000	10.800	30.000	0.0000	0.0000
8	-7.1312E-03	-4.8394E-05	-1450.5	-753.61	-1032.1	-84.519	-294.99	-16.648	1141.2	7.8279E+06	7.8279E+06
x (M)	0.0000	11.700	6.6000	0.0000	0.0000	9.3000	4.2000	16.200	30.000	0.0000	0.0000
9	-7.1312E-03	-4.6095E-05	-1723.4	-866.51	-1324.8	-107.07	-415.87	-25.941	3903.9	7.8279E+06	7.8279E+06
x (M)	0.0000	10.800	6.3000	0.0000	0.0000	8.7000	4.2000	10.800	30.000	0.0000	0.0000
Min.	-7.2909E-03	-5.0240E-05	-1770.9	-870.32	-1369.0	-107.84	-429.84	-26.112	28.811	7.8279E+06	7.8279E+06
Pile N.	1	7	3	3	3	3	3	3	1	1	1

* MAXIMUM VALUES AND LOCATIONS *

PILE	DISPL.	DISPL.	MOMENT	MOMENT	SHEAR	SHEAR	SOIL REACT	SOIL REACT	TOTAL	FLEX. RIG.	FLEX. RIG.
	y-DIR	z-DIR	z-DIR	y-DIR	y-DIR	z-DIR	y-DIR	z-DIR	STRESS	z-DIR	y-DIR
	M	M	KN- M	KN- M	KN	KN	KN/ M	KN/ M	KN/ M**2	KN- M**2	KN- M**2
*****	*****	*****	*****	*****	*****	*****	*****	*****	*****	*****	*****
1	1.7697E-04	2.0892E-03	3068.5	431.75	321.24	304.35	64.027	88.687	9620.2	7.8279E+06	7.8279E+06
x (M)	11.700	0.0000	0.0000	6.6000	9.3000	0.0000	10.800	4.2000	0.0000	0.0000	0.0000
2	1.7828E-04	2.0093E-03	3045.2	412.23	319.16	284.14	62.946	83.252	1.2369E+04	7.8279E+06	7.8279E+06
x (M)	11.700	0.0000	0.0000	6.6000	9.3000	0.0000	10.800	4.2000	0.0000	0.0000	0.0000
3	1.7742E-04	1.9295E-03	3670.6	464.29	414.08	341.50	100.91	109.50	1.6495E+04	7.8279E+06	7.8279E+06
x (M)	10.800	0.0000	0.0000	6.0000	8.7000	0.0000	10.800	4.2000	0.0000	0.0000	0.0000
4	1.7172E-04	2.0892E-03	2735.5	397.72	277.99	269.80	60.921	75.244	9468.0	7.8279E+06	7.8279E+06
x (M)	12.000	0.0000	0.0000	6.9000	9.6000	0.0000	16.200	4.2000	0.0000	0.0000	0.0000
5	1.7296E-04	2.0093E-03	2721.1	380.52	277.27	252.32	60.876	70.899	1.0492E+04	7.8279E+06	7.8279E+06
x (M)	12.000	0.0000	0.0000	6.9000	9.9000	0.0000	16.200	4.2000	0.0000	0.0000	0.0000
6	1.7698E-04	1.9295E-03	3459.7	447.50	384.88	323.45	90.704	101.80	1.5246E+04	7.8279E+06	7.8279E+06
x (M)	11.100	0.0000	0.0000	6.3000	9.0000	0.0000	10.800	4.2000	0.0000	0.0000	0.0000
7	1.7293E-04	2.0892E-03	2913.7	425.98	305.36	299.34	61.200	86.464	1.0911E+04	7.8279E+06	7.8279E+06
x (M)	11.700	0.0000	0.0000	6.6000	9.6000	0.0000	16.200	4.2000	0.0000	0.0000	0.0000
8	1.7403E-04	2.0093E-03	2890.2	406.63	303.55	279.26	61.226	81.108	1.0156E+04	7.8279E+06	7.8279E+06
x (M)	11.700	0.0000	0.0000	6.6000	9.6000	0.0000	16.200	4.2000	0.0000	0.0000	0.0000
9	1.7371E-04	1.9295E-03	3530.5	462.47	401.21	340.21	97.763	108.81	1.4875E+04	7.8279E+06	7.8279E+06
x (M)	10.800	0.0000	0.0000	6.0000	8.7000	0.0000	10.800	4.2000	0.0000	0.0000	0.0000

APPALTATORE: Consorzio Soci   	ITINERARIO NAPOLI – BARI RADDOPPIO TRATTA APICE – ORSARA I LOTTO FUNZIONALE APICE – HIRPINIA
PROGETTAZIONE: Mandataria Mandanti   	
PROGETTO ESECUTIVO RELAZIONE DI CALCOLO FONDAZIONI PILE P1, P2, P21, P22, P23 E P24	COMMESSA IF28 LOTTO 01 CODIFICA E ZZ CL DOCUMENTO VI0403 002 REV. B FOGLIO 137 di 161

Max. Pile N.	1.7828E-04 2	2.0892E-03 1	3670.6 3	464.29 3	414.08 3	341.50 3	100.91 3	109.50 3	1.6495E+04 3	7.8279E+06 1	7.8279E+06 1
--------------	-----------------	-----------------	-------------	-------------	-------------	-------------	-------------	-------------	-----------------	-----------------	-----------------

LOAD CASE : 11
CASE NAME : Load Case
LOAD TYPE : Special, Sp

REDUCTION FACTORS FOR CLOSELY-SPACED PILE GROUPS, COMBINED Y AND Z DIRECTIONS
ESTIMATED USING MOVEMENT IN THE DIRECTION OF PILE CAP DISPLACEMENTS

GROUP NO	P-FACTOR	Y-FACTOR
1	0.8454	1.0000
2	0.5724	1.0000
3	0.5845	1.0000
4	0.7882	1.0000
5	0.4962	1.0000
6	0.5043	1.0000
7	0.8661	1.0000
8	0.6021	1.0000
9	0.6141	1.0000

* TABLE L * COMPUTATION ON PILE CAP

* EQUIVALENT CONCENTRATED LOAD AT ORIGIN *

VERT. LOAD, KN	HOR. LOAD Y, KN	HOR. LOAD Z, KN
40569.0	3786.00	-1067.00
MOMENT X, KN- M	MOMENT Y, KN- M	MOMENT Z, KN- M
-361.000	-17067.5	-44997.0

* DISPLACEMENT OF GROUPED PILE FOUNDATION AT ORIGIN *

VERTICAL, M	HORIZONTAL Y, M	HORIZONTAL Z, M
2.16522E-03	2.23587E-03	-6.89376E-04
ANGLE ROT. X, RAD	ANGLE ROT. Y, RAD	ANGLE ROT. Z, RAD
-8.25881E-07	-8.17283E-05	-2.22622E-04

THE GLOBAL STRUCTURAL COORDINATE SYSTEM

* PILE TOP DISPLACEMENTS *

PILE GROUP	DISP. X, M	DISP. Y, M	DISP. Z, M	ROT. X, RAD	ROT. Y, RAD	ROT. Z, RAD
1	2.7992E-03	2.2396E-03	-6.9309E-04	-8.2588E-07	-8.1728E-05	-2.2262E-04
2	1.7974E-03	2.2396E-03	-6.8938E-04	-8.2588E-07	-8.1728E-05	-2.2262E-04
3	7.9565E-04	2.2396E-03	-6.8566E-04	-8.2588E-07	-8.1728E-05	-2.2262E-04
4	3.1670E-03	2.2359E-03	-6.9309E-04	-8.2588E-07	-8.1728E-05	-2.2262E-04
5	2.1652E-03	2.2359E-03	-6.8938E-04	-8.2588E-07	-8.1728E-05	-2.2262E-04
6	1.1634E-03	2.2359E-03	-6.8566E-04	-8.2588E-07	-8.1728E-05	-2.2262E-04
7	3.5348E-03	2.2322E-03	-6.9309E-04	-8.2588E-07	-8.1728E-05	-2.2262E-04
8	2.5330E-03	2.2322E-03	-6.8938E-04	-8.2588E-07	-8.1728E-05	-2.2262E-04
9	1.5312E-03	2.2322E-03	-6.8566E-04	-8.2588E-07	-8.1728E-05	-2.2262E-04
MINIMUM Pile N.	7.9565E-04 3	2.2322E-03 7	-6.9309E-04 1	-8.2588E-07 1	-8.1728E-05 1	-2.2262E-04 1
MAXIMUM Pile N.	3.5348E-03 7	2.2396E-03 1	-6.8566E-04 3	-8.2588E-07 1	-8.1728E-05 1	-2.2262E-04 1

* PILE TOP REACTIONS *

PILE GROUP	FOR. X, KN	FOR. Y, KN	FOR. Z, KN	MOM X, KN- M	MOM Y, KN- M	MOM Z, KN- M
1	5813.1	501.50	-142.97	-0.2921	312.69	1187.0
2	3779.1	388.14	-108.68	-0.2921	242.10	955.22
3	1745.1	393.76	-109.37	-0.2921	241.89	965.21
4	6559.8	481.79	-137.47	-0.2921	302.88	1150.0
5	4525.8	354.64	-99.162	-0.2921	222.84	885.57
6	2491.8	358.79	-99.496	-0.2921	221.98	892.76
7	7143.3	505.51	-144.86	-0.2921	316.43	1192.5
8	5272.5	398.21	-112.18	-0.2921	249.52	974.65
9	3238.5	403.66	-112.81	-0.2921	249.14	984.19
MINIMUM Pile N.	1745.1 3	354.64 5	-144.86 7	-0.2921 1	221.98 6	885.57 5
MAXIMUM Pile N.	7143.3 7	505.51 1	-99.162 3	-0.2921 1	316.43 6	1192.5 5

ITINERARIO NAPOLI – BARI
RADDOPPIO TRATTA APICE – ORSARA
I LOTTO FUNZIONALE APICE – HIRPINIA

Pile N. 7 7 5 1 7 7

THE PILE COORDINATE SYSTEM (LOCAL AXES)

* PILE TOP DISPLACEMENTS *

PILE GROUP	DISP. x, M	DISP. y, M	DISP. z, M	ROT. x,RAD	ROT. y,RAD	ROT. z,RAD
1	2.7992E-03	2.2396E-03	-6.9309E-04	-8.2588E-07	-8.1728E-05	-2.2262E-04
2	1.7974E-03	2.2396E-03	-6.8938E-04	-8.2588E-07	-8.1728E-05	-2.2262E-04
3	7.9565E-04	2.2396E-03	-6.8566E-04	-8.2588E-07	-8.1728E-05	-2.2262E-04
4	3.1670E-03	2.2359E-03	-6.9309E-04	-8.2588E-07	-8.1728E-05	-2.2262E-04
5	2.1652E-03	2.2359E-03	-6.8938E-04	-8.2588E-07	-8.1728E-05	-2.2262E-04
6	1.1634E-03	2.2359E-03	-6.8566E-04	-8.2588E-07	-8.1728E-05	-2.2262E-04
7	3.5348E-03	2.2322E-03	-6.9309E-04	-8.2588E-07	-8.1728E-05	-2.2262E-04
8	2.5330E-03	2.2322E-03	-6.8938E-04	-8.2588E-07	-8.1728E-05	-2.2262E-04
9	1.5312E-03	2.2322E-03	-6.8566E-04	-8.2588E-07	-8.1728E-05	-2.2262E-04
MINIMUM	7.9565E-04	2.2322E-03	-6.9309E-04	-8.2588E-07	-8.1728E-05	-2.2262E-04
Pile N.	3	7	1	1	1	1
MAXIMUM	3.5348E-03	2.2396E-03	-6.8566E-04	-8.2588E-07	-8.1728E-05	-2.2262E-04
Pile N.	7	1	3	1	1	1

* PILE TOP REACTIONS *

PILE GROUP	AXIAL, KN	LAT. y, KN	LAT. z, KN	MOM x, KN- M	MOM y, KN- M	MOM z, KN- M
1	5813.1	501.50	-142.97	-0.2921	312.69	1187.0
2	3779.1	388.14	-108.68	-0.2921	242.10	955.22
3	1745.1	393.76	-109.37	-0.2921	241.89	965.21
4	6559.8	481.79	-137.47	-0.2921	302.88	1150.0
5	4525.8	354.64	-99.162	-0.2921	222.84	885.57
6	2491.8	358.79	-99.496	-0.2921	221.98	892.76
7	7143.3	505.51	-144.86	-0.2921	316.43	1192.5
8	5272.5	398.21	-112.18	-0.2921	249.52	974.65
9	3238.5	403.66	-112.81	-0.2921	249.14	984.19
MINIMUM	1745.1	354.64	-144.86	-0.2921	221.98	885.57
Pile N.	3	5	7	1	6	5
MAXIMUM	7143.3	505.51	-99.162	-0.2921	316.43	1192.5
Pile N.	7	7	5	1	7	7

PILE GROUP	STRESS, KN/ M**2
1	6994.1
2	5112.6
3	3990.6
4	7301.3
5	5317.1
6	4186.5
7	7765.9
8	6020.1
9	4896.7
MINIMUM	3990.6
Pile N.	3
MAXIMUM	7765.9
Pile N.	7

* EFFECTS FOR LATERALLY LOADED PILE *

* MINIMUM VALUES AND LOCATIONS *

PILE	DISPL. y-DIR M	DISPL. z-DIR M	MOMENT z-DIR KN- M	MOMENT y-DIR KN- M	SHEAR y-DIR KN	SHEAR z-DIR KN	SOIL REACT y-DIR KN/ M	SOIL REACT z-DIR KN/ M	TOTAL STRESS KN/ M**2	FLEX. RIG. z-DIR KN- M**2	FLEX. RIG. y-DIR KN- M**2
x(M)	-5.2436E-05	-6.9309E-04	-1187.0	-216.30	-195.30	-143.00	-61.596	-63.423	3289.5	7.8279E+06	7.8279E+06
1	9.6000	0.0000	0.0000	5.4000	7.8000	0.0000	10.800	4.2000	30.000	0.0000	0.0000
x(M)	-6.1816E-05	-6.8938E-04	-955.22	-177.61	-141.70	-108.70	-41.278	-43.682	2138.5	7.8279E+06	7.8279E+06
2	10.5000	0.0000	0.0000	5.7000	8.4000	0.0000	10.800	4.2000	30.000	0.0000	0.0000
x(M)	-6.1235E-05	-6.8566E-04	-965.21	-178.06	-143.42	-109.38	-41.967	-44.172	987.50	7.8279E+06	7.8279E+06
3	10.5000	0.0000	0.0000	5.7000	8.4000	0.0000	10.800	4.2000	30.000	0.0000	0.0000
x(M)	-5.3778E-05	-6.9309E-04	-1150.0	-211.57	-188.80	-137.51	-60.955	-60.201	3712.1	7.8279E+06	7.8279E+06
4	9.6000	0.0000	0.0000	5.4000	7.8000	0.0000	10.800	4.2000	30.000	0.0000	0.0000
x(M)	-6.5130E-05	-6.8938E-04	-885.57	-167.53	-128.63	-99.182	-36.385	-38.634	2561.1	7.8279E+06	7.8279E+06
5	10.8000	0.0000	0.0000	6.0000	8.4000	0.0000	10.800	4.2000	30.000	0.0000	0.0000
x(M)	-6.4657E-05	-6.8566E-04	-892.76	-167.60	-129.91	-99.507	-36.900	-38.913	1410.1	7.8279E+06	7.8279E+06
6	10.8000	0.0000	0.0000	5.7000	8.4000	0.0000	10.800	4.2000	30.000	0.0000	0.0000
x(M)	-5.1732E-05	-6.9309E-04	-1192.5	-218.17	-196.98	-144.90	-61.531	-64.680	4042.3	7.8279E+06	7.8279E+06
7	9.6000	0.0000	0.0000	5.4000	7.8000	0.0000	10.800	4.2000	30.000	0.0000	0.0000
x(M)	-6.0466E-05	-6.8938E-04	-974.65	-181.53	-146.67	-112.21	-42.947	-45.691	2983.6	7.8279E+06	7.8279E+06
8	10.5000	0.0000	0.0000	5.7000	8.1000	0.0000	10.800	4.2000	30.000	0.0000	0.0000
x(M)	-5.9860E-05	-6.8566E-04	-984.19	-181.87	-148.66	-112.82	-43.587	-46.151	1832.6	7.8279E+06	7.8279E+06
9	10.5000	0.0000	0.0000	5.7000	8.1000	0.0000	10.800	4.2000	30.000	0.0000	0.0000
x(M)	10.5000	0.0000	0.0000	5.7000	8.1000	0.0000	10.800	4.2000	30.000	0.0000	0.0000

APPALDATTORE: Consorzio HirpiniaAV Soci salini impregilo ASTALDI	ITINERARIO NAPOLI – BARI RADDOPPIO TRATTA APICE – ORSARA I LOTTO FUNZIONALE APICE – HIRPINIA					
PROGETTAZIONE: Mandataria ROKSOJL Mandanti NETENGINEERING Alpina						
PROGETTO ESECUTIVO RELAZIONE DI CALCOLO FONDAZIONI PILE P1, P2, P21, P22, P23 E P24						
	COMMESSA	LOTTO	CODIFICA	DOCUMENTO	REV.	FOGLIO
	IF28	01	E ZZ CL	VI0403 002	B	139 di 161

Min. -6.5130E-05 -6.9309E-04 -1192.5 -218.17 -196.98 -144.90 -61.596 -64.680 987.50 7.8279E+06 7.8279E+06
 Pile N. 5 1 7 7 7 7 1 7 3 1 1

* MAXIMUM VALUES AND LOCATIONS *

PILE	DISPL. y-DIR M	DISPL. z-DIR M	MOMENT z-DIR KN- M	MOMENT y-DIR KN- M	SHEAR y-DIR KN	SHEAR z-DIR KN	SOIL REACT y-DIR KN/ M	SOIL REACT z-DIR KN/ M	TOTAL STRESS KN/ M**2	FLEX. RIG. z-DIR KN- M**2	FLEX. RIG. y-DIR KN- M**2
*****	*****	*****	*****	*****	*****	*****	*****	*****	*****	*****	*****
1	2.2396E-03	1.5770E-05	708.40	312.69	501.63	59.059	215.95	18.178	6994.1	7.8279E+06	7.8279E+06
x(M)	0.0000	9.6000	5.7000	0.0000	0.0000	7.5000	4.2000	10.800	0.0000	0.0000	0.0000
2	2.2396E-03	1.8411E-05	583.02	242.10	388.21	42.842	150.16	12.227	5112.6	7.8279E+06	7.8279E+06
x(M)	0.0000	10.500	6.0000	0.0000	0.0000	8.1000	4.2000	10.800	0.0000	0.0000	0.0000
3	2.2396E-03	1.8104E-05	587.63	241.89	393.79	43.185	152.94	12.339	3990.6	7.8279E+06	7.8279E+06
x(M)	0.0000	10.500	6.0000	0.0000	0.0000	8.1000	4.2000	10.800	0.0000	0.0000	0.0000
4	2.2359E-03	1.6236E-05	693.05	302.88	481.94	57.159	204.59	18.049	7301.3	7.8279E+06	7.8279E+06
x(M)	0.0000	9.6000	5.7000	0.0000	0.0000	7.8000	4.2000	10.800	0.0000	0.0000	0.0000
5	2.2359E-03	1.9431E-05	549.68	222.84	354.72	38.970	132.61	10.855	5317.1	7.8279E+06	7.8279E+06
x(M)	0.0000	10.800	6.0000	0.0000	0.0000	8.4000	4.2000	10.800	0.0000	0.0000	0.0000
6	2.2359E-03	1.9152E-05	553.10	221.98	358.83	39.092	134.54	10.930	4186.5	7.8279E+06	7.8279E+06
x(M)	0.0000	10.800	6.0000	0.0000	0.0000	8.4000	4.2000	10.800	0.0000	0.0000	0.0000
7	2.2321E-03	1.5607E-05	711.34	316.43	505.67	59.942	219.28	18.278	7765.9	7.8279E+06	7.8279E+06
x(M)	0.0000	9.6000	5.7000	0.0000	0.0000	7.5000	4.2000	10.500	0.0000	0.0000	0.0000
8	2.2321E-03	1.8042E-05	593.25	249.52	398.31	44.566	156.36	12.756	6020.1	7.8279E+06	7.8279E+06
x(M)	0.0000	10.500	6.0000	0.0000	0.0000	8.1000	4.2000	10.500	0.0000	0.0000	0.0000
9	2.2321E-03	1.7731E-05	597.89	249.14	403.72	44.859	159.07	12.869	4896.7	7.8279E+06	7.8279E+06
x(M)	0.0000	10.500	5.7000	0.0000	0.0000	8.1000	4.2000	10.500	0.0000	0.0000	0.0000
Max.	2.2396E-03	1.9431E-05	711.34	316.43	505.67	59.942	219.28	18.278	7765.9	7.8279E+06	7.8279E+06
Pile N.	1	5	7	7	7	7	7	7	7	1	1

LOAD CASE : 12
 CASE NAME : Load Case
 LOAD TYPE : Special, Sp

REDUCTION FACTORS FOR CLOSELY-SPACED PILE GROUPS, COMBINED Y AND Z DIRECTIONS
 ESTIMATED USING MOVEMENT IN THE DIRECTION OF PILE CAP DISPLACEMENTS

GROUP NO	P-FACTOR	Y-FACTOR
1	0.6972	1.0000
2	0.5272	1.0000
3	0.5845	1.0000
4	0.6678	1.0000
5	0.4962	1.0000
6	0.5513	1.0000
7	0.8661	1.0000
8	0.7334	1.0000
9	0.7783	1.0000

* TABLE L * COMPUTATION ON PILE CAP

* EQUIVALENT CONCENTRATED LOAD AT ORIGIN *

VERT. LOAD, KN 44090.0	HOR. LOAD Y, KN 1340.00	HOR. LOAD Z, KN -1605.00
MOMENT X, KN- M -5.00000	MOMENT Y, KN- M -25249.5	MOMENT Z, KN- M -13499.0

* DISPLACEMENT OF GROUPED PILE FOUNDATION AT ORIGIN *

VERTICAL, M 2.34897E-03	HORIZONTAL Y, M 6.90863E-04	HORIZONTAL Z, M -9.34423E-04
ANGLE ROT. X, RAD -1.15834E-06	ANGLE ROT. Y, RAD -1.16471E-04	ANGLE ROT. Z, RAD -6.79675E-05

THE GLOBAL STRUCTURAL COORDINATE SYSTEM

* PILE TOP DISPLACEMENTS *

PILE GROUP	DISP. X, M	DISP. Y, M	DISP. Z, M	ROT. X, RAD	ROT. Y, RAD	ROT. Z, RAD
*****	*****	*****	*****	*****	*****	*****
1	2.1307E-03	6.9608E-04	-9.3963E-04	-1.1583E-06	-1.1647E-04	-6.7968E-05
2	1.8249E-03	6.9608E-04	-9.3442E-04	-1.1583E-06	-1.1647E-04	-6.7968E-05
3	1.5190E-03	6.9608E-04	-9.2921E-04	-1.1583E-06	-1.1647E-04	-6.7968E-05
4	2.6548E-03	6.9086E-04	-9.3963E-04	-1.1583E-06	-1.1647E-04	-6.7968E-05

APPALTATORE:

Consorzio

Soci



ITINERARIO NAPOLI – BARI

PROGETTAZIONE:

Mandataria

Mandanti



RADDOPPIO TRATTA APICE – ORSARA
I LOTTO FUNZIONALE APICE – HIRPINIA

PROGETTO ESECUTIVO

RELAZIONE DI CALCOLO FONDAZIONI PILE P1, P2, P21, P22, P23
E P24

COMMESSA LOTTO CODIFICA DOCUMENTO REV. FOGLIO
IF28 01 E ZZ CL VI0403 002 B 140 di 161

5	2.3490E-03	6.9086E-04	-9.3442E-04	-1.1583E-06	-1.1647E-04	-6.7968E-05
6	2.0431E-03	6.9086E-04	-9.2921E-04	-1.1583E-06	-1.1647E-04	-6.7968E-05
7	3.1789E-03	6.8565E-04	-9.3963E-04	-1.1583E-06	-1.1647E-04	-6.7968E-05
8	2.8731E-03	6.8565E-04	-9.3442E-04	-1.1583E-06	-1.1647E-04	-6.7968E-05
9	2.5672E-03	6.8565E-04	-9.2921E-04	-1.1583E-06	-1.1647E-04	-6.7968E-05
MINIMUM	1.5190E-03	6.8565E-04	-9.3963E-04	-1.1583E-06	-1.1647E-04	-6.7968E-05
Pile N.	3	7	1	1	1	1
MAXIMUM	3.1789E-03	6.9608E-04	-9.2921E-04	-1.1583E-06	-1.1647E-04	-6.7968E-05
Pile N.	7	1	3	1	1	1

* PILE TOP REACTIONS *

PILE GROUP	FOR. X, KN	FOR. Y, KN	FOR. Z, KN	MOM X, KN- M	MOM Y, KN- M	MOM Z, KN- M
1	4455.7	155.85	-186.57	-0.4097	404.53	378.38
2	3834.7	135.30	-159.17	-0.4097	350.55	338.79
3	3213.7	142.76	-166.97	-0.4097	363.63	353.28
4	5519.9	150.82	-182.26	-0.4097	396.91	367.29
5	4898.9	129.71	-153.96	-0.4097	340.73	326.25
6	4277.9	137.05	-161.72	-0.4097	353.92	340.63
7	6584.1	170.31	-209.49	-0.4097	446.88	401.49
8	5963.1	156.62	-190.12	-0.4097	409.73	376.39
9	5342.1	161.59	-194.74	-0.4097	416.03	385.48
MINIMUM	3213.7	129.71	-209.49	-0.4097	340.73	326.25
Pile N.	3	5	7	1	5	5
MAXIMUM	6584.1	170.31	-153.96	-0.4097	446.88	401.49
Pile N.	7	7	5	1	7	7

THE PILE COORDINATE SYSTEM (LOCAL AXES)

* PILE TOP DISPLACEMENTS *

PILE GROUP	DISP. x, M	DISP. y, M	DISP. z, M	ROT. x,RAD	ROT. y,RAD	ROT. z,RAD
1	2.1307E-03	6.9608E-04	-9.3963E-04	-1.1583E-06	-1.1647E-04	-6.7968E-05
2	1.8249E-03	6.9608E-04	-9.3442E-04	-1.1583E-06	-1.1647E-04	-6.7968E-05
3	1.5190E-03	6.9608E-04	-9.2921E-04	-1.1583E-06	-1.1647E-04	-6.7968E-05
4	2.6548E-03	6.9086E-04	-9.3963E-04	-1.1583E-06	-1.1647E-04	-6.7968E-05
5	2.3490E-03	6.9086E-04	-9.3442E-04	-1.1583E-06	-1.1647E-04	-6.7968E-05
6	2.0431E-03	6.9086E-04	-9.2921E-04	-1.1583E-06	-1.1647E-04	-6.7968E-05
7	3.1789E-03	6.8565E-04	-9.3963E-04	-1.1583E-06	-1.1647E-04	-6.7968E-05
8	2.8731E-03	6.8565E-04	-9.3442E-04	-1.1583E-06	-1.1647E-04	-6.7968E-05
9	2.5672E-03	6.8565E-04	-9.2921E-04	-1.1583E-06	-1.1647E-04	-6.7968E-05
MINIMUM	1.5190E-03	6.8565E-04	-9.3963E-04	-1.1583E-06	-1.1647E-04	-6.7968E-05
Pile N.	3	7	1	1	1	1
MAXIMUM	3.1789E-03	6.9608E-04	-9.2921E-04	-1.1583E-06	-1.1647E-04	-6.7968E-05
Pile N.	7	1	3	1	1	1

* PILE TOP REACTIONS *

PILE GROUP	AXIAL, KN	LAT. y, KN	LAT. z, KN	MOM x, KN- M	MOM y, KN- M	MOM z, KN- M
1	4455.7	155.85	-186.57	-0.4097	404.53	378.38
2	3834.7	135.30	-159.17	-0.4097	350.55	338.79
3	3213.7	142.76	-166.97	-0.4097	363.63	353.28
4	5519.9	150.82	-182.26	-0.4097	396.91	367.29
5	4898.9	129.71	-153.96	-0.4097	340.73	326.25
6	4277.9	137.05	-161.72	-0.4097	353.92	340.63
7	6584.1	170.31	-209.49	-0.4097	446.88	401.49
8	5963.1	156.62	-190.12	-0.4097	409.73	376.39
9	5342.1	161.59	-194.74	-0.4097	416.03	385.48
MINIMUM	3213.7	129.71	-209.49	-0.4097	340.73	326.25
Pile N.	3	5	7	1	5	5
MAXIMUM	6584.1	170.31	-153.96	-0.4097	446.88	401.49
Pile N.	7	7	5	1	7	7

PILE GROUP STRESS, KN/ M**2

1	4193.2
2	3641.3
3	3348.7
4	4755.7
5	4195.9
6	3903.3
7	5538.9
8	5053.6
9	4734.7
MINIMUM	3348.7
Pile N.	3
MAXIMUM	5538.9
Pile N.	7

APPALTATORE:

Consorzio

Soci



ITINERARIO NAPOLI – BARI

PROGETTAZIONE:

Mandatario

Mandanti

RADDOPPIO TRATTA APICE – ORSARA
I LOTTO FUNZIONALE APICE – HIRPINIA

PROGETTO ESECUTIVO

RELAZIONE DI CALCOLO FONDAZIONI PILE P1, P2, P21, P22, P23
E P24COMMESSA
IF28LOTTO
01CODIFICA
E ZZ CLDOCUMENTO
VI0403 002REV.
BFOGLIO
141 di
161

* EFFECTS FOR LATERALLY LOADED PILE *

* MINIMUM VALUES AND LOCATIONS *

PILE	DISPL.	DISPL.	MOMENT	MOMENT	SHEAR	SHEAR	SOIL REACT	SOIL REACT	TOTAL	FLEX. RIG.	FLEX. RIG.
	y-DIR M	z-DIR M	z-DIR KN- M	y-DIR KN- M	y-DIR KN	z-DIR KN	y-DIR KN/ M	z-DIR KN/ M	STRESS KN/ M**2	z-DIR KN- M**2	y-DIR KN- M**2
*****	*****	*****	*****	*****	*****	*****	*****	*****	*****	*****	*****
1	-1.6190E-05	-9.3964E-04	-378.38	-305.36	-63.491	-186.60	-20.552	-98.440	2521.4	7.8279E+06	7.8279E+06
x(M)	9.6000	0.0000	0.0000	5.4000	7.5000	0.0000	9.9000	4.2000	30.000	0.0000	0.0000
2	-1.8216E-05	-9.3442E-04	-338.79	-277.46	-54.904	-159.19	-18.179	-79.181	2170.0	7.8279E+06	7.8279E+06
x(M)	9.9000	0.0000	0.0000	5.4000	7.8000	0.0000	4.2000	4.2000	30.000	0.0000	0.0000
3	-1.7428E-05	-9.2921E-04	-353.28	-285.55	-58.053	-167.00	-19.015	-85.201	1818.6	7.8279E+06	7.8279E+06
x(M)	9.9000	0.0000	0.0000	5.4000	7.8000	0.0000	4.2000	4.2000	30.000	0.0000	0.0000
4	-1.6363E-05	-9.3964E-04	-367.29	-301.53	-61.577	-182.30	-20.012	-95.450	3123.6	7.8279E+06	7.8279E+06
x(M)	9.6000	0.0000	0.0000	5.4000	7.5000	0.0000	9.9000	4.2000	30.000	0.0000	0.0000
5	-1.8590E-05	-9.3442E-04	-326.25	-272.27	-52.686	-153.99	-17.609	-75.663	2772.2	7.8279E+06	7.8279E+06
x(M)	10.200	0.0000	0.0000	5.7000	7.8000	0.0000	10.500	4.2000	30.000	0.0000	0.0000
6	-1.7751E-05	-9.2921E-04	-340.63	-280.34	-55.895	-161.75	-18.395	-81.593	2420.8	7.8279E+06	7.8279E+06
x(M)	9.9000	0.0000	0.0000	5.4000	7.8000	0.0000	10.200	4.2000	30.000	0.0000	0.0000
7	-1.4675E-05	-9.3964E-04	-401.49	-326.48	-69.834	-209.55	-22.546	-115.87	3725.8	7.8279E+06	7.8279E+06
x(M)	9.3000	0.0000	0.0000	5.1000	7.5000	0.0000	9.3000	4.2000	30.000	0.0000	0.0000
8	-1.5616E-05	-9.3442E-04	-376.39	-308.87	-64.361	-190.16	-20.729	-101.92	3374.4	7.8279E+06	7.8279E+06
x(M)	9.3000	0.0000	0.0000	5.4000	7.5000	0.0000	9.6000	4.2000	30.000	0.0000	0.0000
9	-1.5311E-05	-9.2921E-04	-385.48	-312.65	-66.381	-194.79	-21.362	-105.91	3023.0	7.8279E+06	7.8279E+06
x(M)	9.3000	0.0000	0.0000	5.4000	7.5000	0.0000	9.6000	4.2000	30.000	0.0000	0.0000
Min.	-1.8590E-05	-9.3964E-04	-401.49	-326.48	-69.834	-209.55	-22.546	-115.87	1818.6	7.8279E+06	7.8279E+06
Pile N.	5	1	7	7	7	7	7	7	3	1	1

* MAXIMUM VALUES AND LOCATIONS *



PILE	DISPL.	DISPL.	MOMENT	MOMENT	SHEAR	SHEAR	SOIL REACT	SOIL REACT	TOTAL	FLEX. RIG.	FLEX. RIG.
	y-DIR M	z-DIR M	z-DIR KN- M	y-DIR KN- M	y-DIR KN	z-DIR KN	y-DIR KN/ M	z-DIR KN/ M	STRESS KN/ M**2	z-DIR KN- M**2	y-DIR KN- M**2
*****	*****	*****	*****	*****	*****	*****	*****	*****	*****	*****	*****
1	6.9608E-04	2.1067E-05	230.90	404.53	155.88	83.453	78.549	26.565	4193.2	7.8279E+06	7.8279E+06
x(M)	0.0000	9.3000	5.4000	0.0000	0.0000	7.5000	4.2000	9.6000	0.0000	0.0000	0.0000
2	6.9608E-04	2.3517E-05	211.47	350.55	135.32	71.740	63.756	23.244	3641.3	7.8279E+06	7.8279E+06
x(M)	0.0000	9.9000	5.7000	0.0000	0.0000	7.8000	4.2000	10.200	0.0000	0.0000	0.0000
3	6.9608E-04	2.2336E-05	218.60	363.63	142.79	75.069	69.092	24.129	3348.7	7.8279E+06	7.8279E+06
x(M)	0.0000	9.6000	5.7000	0.0000	0.0000	7.8000	4.2000	9.9000	0.0000	0.0000	0.0000
4	6.9086E-04	2.1443E-05	225.95	396.91	150.86	81.727	75.458	26.004	4755.7	7.8279E+06	7.8279E+06
x(M)	0.0000	9.6000	5.4000	0.0000	0.0000	7.5000	4.2000	9.9000	0.0000	0.0000	0.0000
5	6.9086E-04	2.4148E-05	205.81	340.73	129.74	69.578	60.364	22.619	4195.9	7.8279E+06	7.8279E+06
x(M)	0.0000	9.9000	5.7000	0.0000	0.0000	7.8000	4.2000	10.200	0.0000	0.0000	0.0000
6	6.9086E-04	2.2916E-05	213.05	353.92	137.07	73.038	65.558	23.545	3903.3	7.8279E+06	7.8279E+06
x(M)	0.0000	9.9000	5.7000	0.0000	0.0000	7.8000	4.2000	10.200	0.0000	0.0000	0.0000
7	6.8565E-04	1.9567E-05	243.82	446.88	170.36	93.009	90.616	29.790	5538.9	7.8279E+06	7.8279E+06
x(M)	0.0000	9.0000	5.4000	0.0000	0.0000	7.2000	9.3000	4.2000	0.0000	0.0000	0.0000
8	6.8565E-04	2.0630E-05	231.50	409.73	156.66	85.307	80.377	27.126	5053.6	7.8279E+06	7.8279E+06
x(M)	0.0000	9.3000	5.4000	0.0000	0.0000	7.5000	4.2000	9.6000	0.0000	0.0000	0.0000
9	6.8565E-04	2.0046E-05	236.11	416.03	161.63	87.249	84.135	27.710	4734.7	7.8279E+06	7.8279E+06
x(M)	0.0000	9.3000	5.4000	0.0000	0.0000	7.5000	4.2000	9.6000	0.0000	0.0000	0.0000
Max.	6.9608E-04	2.4148E-05	243.82	446.88	170.36	93.009	90.616	29.790	5538.9	7.8279E+06	7.8279E+06
Pile N.	1	5	7	7	7	7	7	7	7	1	1

LOAD CASE : 13
CASE NAME : Load Case
LOAD TYPE : Special, SpREDUCTION FACTORS FOR CLOSELY-SPACED PILE GROUPS, COMBINED Y AND Z DIRECTIONS
ESTIMATED USING MOVEMENT IN THE DIRECTION OF PILE CAP DISPLACEMENTS

GROUP NO	P-FACTOR	Y-FACTOR
1	0.7540	1.0000
2	0.5439	1.0000
3	0.5845	1.0000
4	0.7136	1.0000
5	0.4962	1.0000
6	0.5348	1.0000
7	0.8661	1.0000
8	0.6889	1.0000
9	0.7234	1.0000

* TABLE L * COMPUTATION ON PILE CAP

* EQUIVALENT CONCENTRATED LOAD AT ORIGIN *

APPALTATORE: Consorzio  Soci  		ITINERARIO NAPOLI – BARI RADDOPPIO TRATTA APICE – ORSARA I LOTTO FUNZIONALE APICE – HIRPINIA					
PROGETTAZIONE: Mandataria  Mandanti  							
PROGETTO ESECUTIVO RELAZIONE DI CALCOLO FONDAZIONI PILE P1, P2, P21, P22, P23 E P24							COMMESSA IF28

VERT. LOAD, KN HOR. LOAD Y, KN HOR. LOAD Z, KN
 44090.0 2002.00 -1605.00

 MOMENT X, KN- M MOMENT Y, KN- M MOMENT Z, KN- M
 -5.00000 -25249.5 -21147.0

*** DISPLACEMENT OF GROUPED PILE FOUNDATION AT ORIGIN ***

VERTICAL, M HORIZONTAL Y, M HORIZONTAL Z, M
 2.35184E-03 1.06683E-03 -9.54470E-04

 ANGLE ROT. X, RAD ANGLE ROT. Y, RAD ANGLE ROT. Z, RAD
 1.21492E-07 -1.17506E-04 -1.06379E-04

THE GLOBAL STRUCTURAL COORDINATE SYSTEM

*** PILE TOP DISPLACEMENTS ***

PILE GROUP	DISP. X, M	DISP. Y, M	DISP. Z, M	ROT. X, RAD	ROT. Y, RAD	ROT. Z, RAD
*****	*****	*****	*****	*****	*****	*****
1	2.3018E-03	1.0663E-03	-9.5392E-04	1.2149E-07	-1.1751E-04	-1.0638E-04
2	1.8231E-03	1.0663E-03	-9.5447E-04	1.2149E-07	-1.1751E-04	-1.0638E-04
3	1.3444E-03	1.0663E-03	-9.5502E-04	1.2149E-07	-1.1751E-04	-1.0638E-04
4	2.8305E-03	1.0668E-03	-9.5392E-04	1.2149E-07	-1.1751E-04	-1.0638E-04
5	2.3518E-03	1.0668E-03	-9.5447E-04	1.2149E-07	-1.1751E-04	-1.0638E-04
6	1.8731E-03	1.0668E-03	-9.5502E-04	1.2149E-07	-1.1751E-04	-1.0638E-04
7	3.3593E-03	1.0674E-03	-9.5392E-04	1.2149E-07	-1.1751E-04	-1.0638E-04
8	2.8806E-03	1.0674E-03	-9.5447E-04	1.2149E-07	-1.1751E-04	-1.0638E-04
9	2.4019E-03	1.0674E-03	-9.5502E-04	1.2149E-07	-1.1751E-04	-1.0638E-04
MINIMUM	1.3444E-03	1.0663E-03	-9.5502E-04	1.2149E-07	-1.1751E-04	-1.0638E-04
Pile N.	3	1	3	1	1	1
MAXIMUM	3.3593E-03	1.0674E-03	-9.5392E-04	1.2149E-07	-1.1751E-04	-1.0638E-04
Pile N.	7	7	1	1	1	1

*** PILE TOP REACTIONS ***

PILE GROUP	FOR. X, KN	FOR. Y, KN	FOR. Z, KN	MOM X, KN- M	MOM Y, KN- M	MOM Z, KN- M
*****	*****	*****	*****	*****	*****	*****
1	4803.1	239.87	-193.01	0.042968	416.63	573.06
2	3831.1	202.61	-161.75	0.042968	357.70	501.80
3	2859.1	210.46	-168.53	0.042968	370.62	516.77
4	5876.7	233.13	-187.16	0.042968	406.21	561.08
5	4904.7	193.13	-153.65	0.042968	342.20	483.60
6	3932.8	200.96	-160.38	0.042968	355.25	498.76
7	6897.9	257.76	-207.81	0.042968	443.98	606.80
8	5978.3	229.03	-183.73	0.042968	400.08	553.62
9	5006.4	235.04	-188.98	0.042968	409.69	564.54
MINIMUM	2859.1	193.13	-207.81	0.042968	342.20	483.60
Pile N.	3	5	7	1	5	5
MAXIMUM	6897.9	257.76	-153.65	0.042968	443.98	606.80
Pile N.	7	7	5	1	7	7

THE PILE COORDINATE SYSTEM (LOCAL AXES)

*** PILE TOP DISPLACEMENTS ***

PILE GROUP	DISP. x, M	DISP. y, M	DISP. z, M	ROT. x, RAD	ROT. y, RAD	ROT. z, RAD
*****	*****	*****	*****	*****	*****	*****
1	2.3018E-03	1.0663E-03	-9.5392E-04	1.2149E-07	-1.1751E-04	-1.0638E-04
2	1.8231E-03	1.0663E-03	-9.5447E-04	1.2149E-07	-1.1751E-04	-1.0638E-04
3	1.3444E-03	1.0663E-03	-9.5502E-04	1.2149E-07	-1.1751E-04	-1.0638E-04
4	2.8305E-03	1.0668E-03	-9.5392E-04	1.2149E-07	-1.1751E-04	-1.0638E-04
5	2.3518E-03	1.0668E-03	-9.5447E-04	1.2149E-07	-1.1751E-04	-1.0638E-04
6	1.8731E-03	1.0668E-03	-9.5502E-04	1.2149E-07	-1.1751E-04	-1.0638E-04
7	3.3593E-03	1.0674E-03	-9.5392E-04	1.2149E-07	-1.1751E-04	-1.0638E-04
8	2.8806E-03	1.0674E-03	-9.5447E-04	1.2149E-07	-1.1751E-04	-1.0638E-04
9	2.4019E-03	1.0674E-03	-9.5502E-04	1.2149E-07	-1.1751E-04	-1.0638E-04
MINIMUM	1.3444E-03	1.0663E-03	-9.5502E-04	1.2149E-07	-1.1751E-04	-1.0638E-04
Pile N.	3	1	3	1	1	1
MAXIMUM	3.3593E-03	1.0674E-03	-9.5392E-04	1.2149E-07	-1.1751E-04	-1.0638E-04
Pile N.	7	7	1	1	1	1

*** PILE TOP REACTIONS ***

PILE GROUP	AXIAL, KN	LAT. y, KN	LAT. z, KN	MOM x, KN- M	MOM y, KN- M	MOM z, KN- M
*****	*****	*****	*****	*****	*****	*****
1	4803.1	239.87	-193.01	0.042968	416.63	573.06
2	3831.1	202.61	-161.75	0.042968	357.70	501.80
3	2859.1	210.46	-168.53	0.042968	370.62	516.77

APPALDATTORE: Consorzio Soci HirpiniaAV salini impreglio ASTALDI
PROGETTAZIONE: Mandataria Mandanti ROCKSOIL NETENGINEERING Alpina
PROGETTO ESECUTIVO RELAZIONE DI CALCOLO FONDAZIONI PILE P1, P2, P21, P22, P23 E P24

ITINERARIO NAPOLI - BARI
RADDOPPIO TRATTA APICE - ORSARA
I LOTTO FUNZIONALE APICE - HIRPINIA

Table with 7 columns: COMMESSA (IF28), LOTTO (01), CODIFICA (E ZZ CL), DOCUMENTO (VI0403 002), REV. (B), FOGLIO (143 di 161)

Table with 7 columns: Pile N., Values, Values, Values, Values, Values, Values

PILE GROUP STRESS, KN/ M**2

1 4856.3
2 4027.8
3 3537.2
4 5416.1
5 4563.5
6 4073.6
7 6172.6
8 5444.5
9 4938.2
MINIMUM 3537.2
Pile N. 3
MAXIMUM 6172.6
Pile N. 7

* EFFECTS FOR LATERALLY LOADED PILE *
* MINIMUM VALUES AND LOCATIONS *

Table with columns: PILE, DISPL. y-DIR, DISPL. z-DIR, MOMENT z-DIR, MOMENT y-DIR, SHEAR y-DIR, SHEAR z-DIR, SOIL REACT y-DIR, SOIL REACT z-DIR, TOTAL STRESS, FLEX. RIG. z-DIR, FLEX. RIG. y-DIR

* MAXIMUM VALUES AND LOCATIONS *

Table with columns: PILE, DISPL. y-DIR, DISPL. z-DIR, MOMENT z-DIR, MOMENT y-DIR, SHEAR y-DIR, SHEAR z-DIR, SOIL REACT y-DIR, SOIL REACT z-DIR, TOTAL STRESS, FLEX. RIG. z-DIR, FLEX. RIG. y-DIR

APPALTATORE: Consorzio  Soci  	ITINERARIO NAPOLI – BARI RADDOPPIO TRATTA APICE – ORSARA I LOTTO FUNZIONALE APICE – HIRPINIA												
PROGETTAZIONE: Mandataria  Mandanti  													
PROGETTO ESECUTIVO RELAZIONE DI CALCOLO FONDAZIONI PILE P1, P2, P21, P22, P23 E P24	<table border="1" style="width: 100%; border-collapse: collapse;"> <tr> <td style="width: 15%;">COMMESSA</td> <td style="width: 15%;">LOTTO</td> <td style="width: 15%;">CODIFICA</td> <td style="width: 15%;">DOCUMENTO</td> <td style="width: 15%;">REV.</td> <td style="width: 15%;">FOGLIO</td> </tr> <tr> <td>IF28</td> <td>01</td> <td>E ZZ CL</td> <td>VI0403 002</td> <td>B</td> <td>144 di 161</td> </tr> </table>	COMMESSA	LOTTO	CODIFICA	DOCUMENTO	REV.	FOGLIO	IF28	01	E ZZ CL	VI0403 002	B	144 di 161
COMMESSA	LOTTO	CODIFICA	DOCUMENTO	REV.	FOGLIO								
IF28	01	E ZZ CL	VI0403 002	B	144 di 161								

LOAD CASE : 14
CASE NAME : Load Case
LOAD TYPE : Special, Sp

REDUCTION FACTORS FOR CLOSELY-SPACED PILE GROUPS, COMBINED Y AND Z DIRECTIONS
ESTIMATED USING MOVEMENT IN THE DIRECTION OF PILE CAP DISPLACEMENTS

GROUP NO	P-FACTOR	Y-FACTOR
1	0.6272	1.0000
2	0.5078	1.0000
3	0.5845	1.0000
4	0.6124	1.0000
5	0.4962	1.0000
6	0.5693	1.0000
7	0.8661	1.0000
8	0.7803	1.0000
9	0.8357	1.0000

* TABLE L * COMPUTATION ON PILE CAP

* EQUIVALENT CONCENTRATED LOAD AT ORIGIN *

VERT. LOAD, KN	HOR. LOAD Y, KN	HOR. LOAD Z, KN
28497.0	507.000	-1232.00
MOMENT X, KN- M	MOMENT Y, KN- M	MOMENT Z, KN- M
0.00000	-19151.0	-6046.50

* DISPLACEMENT OF GROUPED PILE FOUNDATION AT ORIGIN *

VERTICAL, M	HORIZONTAL Y, M	HORIZONTAL Z, M
1.49566E-03	2.6217E-04	-6.88406E-04
ANGLE ROT. X, RAD	ANGLE ROT. Y, RAD	ANGLE ROT. Z, RAD
-1.10811E-06	-8.83125E-05	-2.92646E-05

THE GLOBAL STRUCTURAL COORDINATE SYSTEM

* PILE TOP DISPLACEMENTS *

PILE GROUP	DISP. X, M	DISP. Y, M	DISP. Z, M	ROT. X, RAD	ROT. Y, RAD	ROT. Z, RAD
1	1.2299E-03	2.6715E-04	-6.9339E-04	-1.1081E-06	-8.8312E-05	-2.9265E-05
2	1.0983E-03	2.6715E-04	-6.8841E-04	-1.1081E-06	-8.8312E-05	-2.9265E-05
3	9.6656E-04	2.6715E-04	-6.8342E-04	-1.1081E-06	-8.8312E-05	-2.9265E-05
4	1.6274E-03	2.6217E-04	-6.9339E-04	-1.1081E-06	-8.8312E-05	-2.9265E-05
5	1.4957E-03	2.6217E-04	-6.8841E-04	-1.1081E-06	-8.8312E-05	-2.9265E-05
6	1.3640E-03	2.6217E-04	-6.8342E-04	-1.1081E-06	-8.8312E-05	-2.9265E-05
7	2.0248E-03	2.5718E-04	-6.9339E-04	-1.1081E-06	-8.8312E-05	-2.9265E-05
8	1.8931E-03	2.5718E-04	-6.8841E-04	-1.1081E-06	-8.8312E-05	-2.9265E-05
9	1.7614E-03	2.5718E-04	-6.8342E-04	-1.1081E-06	-8.8312E-05	-2.9265E-05
MINIMUM	9.6656E-04	2.5718E-04	-6.9339E-04	-1.1081E-06	-8.8312E-05	-2.9265E-05
Pile N.	3	7	1	1	1	1
MAXIMUM	2.0248E-03	2.6715E-04	-6.8342E-04	-1.1081E-06	-8.8312E-05	-2.9265E-05
Pile N.	7	1	3	1	1	1

* PILE TOP REACTIONS *

PILE GROUP	FOR. X, KN	FOR. Y, KN	FOR. Z, KN	MOM X, KN- M	MOM Y, KN- M	MOM Z, KN- M
1	2626.8	57.096	-136.14	-0.3919	293.49	133.71
2	2359.4	51.365	-120.49	-0.3919	261.75	122.65
3	2092.1	55.236	-128.42	-0.3919	275.24	130.17
4	3433.7	54.821	-134.42	-0.3919	290.47	127.64
5	3166.3	49.310	-118.99	-0.3919	259.05	116.97
6	2899.0	52.961	-126.62	-0.3919	272.03	124.09
7	4240.6	63.464	-161.07	-0.3919	339.34	141.68
8	3973.2	60.274	-150.99	-0.3919	319.32	135.96
9	3705.8	62.472	-154.86	-0.3919	324.24	139.93
MINIMUM	2092.1	49.310	-161.07	-0.3919	259.05	116.97
Pile N.	3	5	7	1	5	5
MAXIMUM	4240.6	63.464	-118.99	-0.3919	339.34	141.68
Pile N.	7	7	5	1	7	7

THE PILE COORDINATE SYSTEM (LOCAL AXES)

APPALTATORE: Consorzio HirpiniaAV Soci salini impreglio ASTALDI			ITINERARIO NAPOLI – BARI RADDOPPIO TRATTA APICE – ORSARA I LOTTO FUNZIONALE APICE – HIRPINIA		
PROGETTAZIONE: Mandataria ROKSOJL Mandanti NETENGINEERING Alpina					
PROGETTO ESECUTIVO RELAZIONE DI CALCOLO FONDAZIONI PILE P1, P2, P21, P22, P23 E P24					
COMMESSA	LOTTO	CODIFICA	DOCUMENTO	REV.	FOGLIO
IF28	01	E ZZ CL	VI0403 002	B	145 di 161

* PILE TOP DISPLACEMENTS *

PILE GROUP	DISP. x, M	DISP. y, M	DISP. z, M	ROT. x, RAD	ROT. y, RAD	ROT. z, RAD
*****	*****	*****	*****	*****	*****	*****
1	1.2299E-03	2.6715E-04	-6.9339E-04	-1.1081E-06	-8.8312E-05	-2.9265E-05
2	1.0983E-03	2.6715E-04	-6.8841E-04	-1.1081E-06	-8.8312E-05	-2.9265E-05
3	9.6656E-04	2.6715E-04	-6.8342E-04	-1.1081E-06	-8.8312E-05	-2.9265E-05
4	1.6274E-03	2.6217E-04	-6.9339E-04	-1.1081E-06	-8.8312E-05	-2.9265E-05
5	1.4957E-03	2.6217E-04	-6.8841E-04	-1.1081E-06	-8.8312E-05	-2.9265E-05
6	1.3640E-03	2.6217E-04	-6.8342E-04	-1.1081E-06	-8.8312E-05	-2.9265E-05
7	2.0248E-03	2.5718E-04	-6.9339E-04	-1.1081E-06	-8.8312E-05	-2.9265E-05
8	1.8931E-03	2.5718E-04	-6.8841E-04	-1.1081E-06	-8.8312E-05	-2.9265E-05
9	1.7614E-03	2.5718E-04	-6.8342E-04	-1.1081E-06	-8.8312E-05	-2.9265E-05
MINIMUM	9.6656E-04	2.5718E-04	-6.9339E-04	-1.1081E-06	-8.8312E-05	-2.9265E-05
Pile N.	3	7	1	1	1	1
MAXIMUM	2.0248E-03	2.6715E-04	-6.8342E-04	-1.1081E-06	-8.8312E-05	-2.9265E-05
Pile N.	7	1	3	1	1	1

* PILE TOP REACTIONS *

PILE GROUP	AXIAL, KN	LAT. y, KN	LAT. z, KN	MOM x, KN- M	MOM y, KN- M	MOM z, KN- M
*****	*****	*****	*****	*****	*****	*****
1	2626.8	57.096	-136.14	-0.3919	293.49	133.71
2	2359.4	51.365	-120.49	-0.3919	261.75	122.65
3	2092.1	55.236	-128.42	-0.3919	275.24	130.17
4	3433.7	54.821	-134.42	-0.3919	290.47	127.64
5	3166.3	49.310	-118.99	-0.3919	259.05	116.97
6	2899.0	52.961	-126.62	-0.3919	272.03	124.09
7	4240.6	63.464	-161.07	-0.3919	339.34	141.68
8	3973.2	60.274	-150.99	-0.3919	319.32	135.96
9	3705.8	62.472	-154.86	-0.3919	324.24	139.93
MINIMUM	2092.1	49.310	-161.07	-0.3919	259.05	116.97
Pile N.	3	5	7	1	5	5
MAXIMUM	4240.6	63.464	-118.99	-0.3919	339.34	141.68
Pile N.	7	7	5	1	7	7





PILE GROUP	STRESS, KN/ M**2
*****	*****
1	2459.8
2	2207.6
3	2102.8
4	2900.6
5	2649.6
6	2542.9
7	3509.5
8	3295.8
9	3162.9
MINIMUM	2102.8
Pile N.	3
MAXIMUM	3509.5
Pile N.	7

* EFFECTS FOR Laterally Loaded Pile *

* MINIMUM VALUES AND LOCATIONS *

PILE	DISPL.		MOMENT		SHEAR		SOIL REACT		TOTAL	FLEX. RIG.	
	y-DIR	z-DIR	y-DIR	z-DIR	y-DIR	z-DIR	y-DIR	z-DIR	STRESS	z-DIR	y-DIR
	M	M	KN- M	KN- M	KN	KN	KN/ M	KN/ M	KN/ M**2	KN- M**2	KN- M**2
*****	*****	*****	*****	*****	*****	*****	*****	*****	*****	*****	*****
1	-6.6761E-06	-6.9339E-04	-133.71	-231.23	-24.312	-136.16	-7.5688	-80.854	1486.5	7.8279E+06	7.8279E+06
x(M)	9.3000	0.0000	0.0000	5.4000	7.5000	0.0000	9.6000	4.2000	30.000	0.0000	0.0000
2	-7.2354E-06	-6.8841E-04	-122.65	-214.85	-21.640	-120.50	-6.8411	-68.559	1335.2	7.8279E+06	7.8279E+06
x(M)	9.9000	0.0000	0.0000	5.4000	7.5000	0.0000	10.200	4.2000	30.000	0.0000	0.0000
3	-6.8636E-06	-6.8342E-04	-130.17	-223.12	-23.462	-128.43	-7.3152	-75.727	1183.9	7.8279E+06	7.8279E+06
x(M)	9.6000	0.0000	0.0000	5.4000	7.5000	0.0000	9.9000	4.2000	30.000	0.0000	0.0000
4	-6.5899E-06	-6.9339E-04	-127.64	-229.67	-23.533	-134.44	-7.3129	-79.531	1943.1	7.8279E+06	7.8279E+06
x(M)	9.3000	0.0000	0.0000	5.4000	7.5000	0.0000	9.6000	4.2000	30.000	0.0000	0.0000
5	-7.1572E-06	-6.8841E-04	-116.97	-213.36	-20.937	-119.01	-6.6255	-67.457	1791.8	7.8279E+06	7.8279E+06
x(M)	9.9000	0.0000	0.0000	5.4000	7.5000	0.0000	10.200	4.2000	30.000	0.0000	0.0000
6	-6.7941E-06	-6.8342E-04	-124.09	-221.42	-22.672	-126.64	-7.0710	-74.345	1640.5	7.8279E+06	7.8279E+06
x(M)	9.6000	0.0000	0.0000	5.4000	7.5000	0.0000	9.9000	4.2000	30.000	0.0000	0.0000
7	-5.7686E-06	-6.9339E-04	-141.68	-256.68	-27.640	-161.10	-8.6600	-102.56	2399.7	7.8279E+06	7.8279E+06
x(M)	9.0000	0.0000	0.0000	5.1000	7.2000	0.0000	9.0000	4.2000	30.000	0.0000	0.0000
8	-5.9727E-06	-6.8841E-04	-135.96	-246.66	-26.232	-151.01	-8.1615	-94.527	2248.4	7.8279E+06	7.8279E+06
x(M)	9.0000	0.0000	0.0000	5.1000	7.2000	0.0000	9.3000	4.2000	30.000	0.0000	0.0000
9	-5.8506E-06	-6.8342E-04	-139.93	-250.38	-27.206	-154.88	-8.4749	-98.678	2097.1	7.8279E+06	7.8279E+06
x(M)	9.0000	0.0000	0.0000	5.1000	7.2000	0.0000	9.0000	4.2000	30.000	0.0000	0.0000
Min.	-7.2354E-06	-6.9339E-04	-141.68	-256.68	-27.640	-161.10	-8.6600	-102.56	1183.9	7.8279E+06	7.8279E+06
Pile N.	2	1	7	7	7	7	7	7	3	1	1

* MAXIMUM VALUES AND LOCATIONS *

APPALTATORE: Consorzio Soci   	<h1 style="text-align: center;">ITINERARIO NAPOLI – BARI</h1> <h2 style="text-align: center;">RADDOPPIO TRATTA APICE – ORSARA</h2> <h3 style="text-align: center;">I LOTTO FUNZIONALE APICE – HIRPINIA</h3>					
PROGETTAZIONE: Mandataria Mandanti   						
PROGETTO ESECUTIVO RELAZIONE DI CALCOLO FONDAZIONI PILE P1, P2, P21, P22, P23 E P24	COMMESSA IF28	LOTTO 01	CODIFICA E ZZ CL	DOCUMENTO VI0403 002	REV. B	FOGLIO 146 di 161

PILE	DISPL.		MOMENT		SHEAR		SOIL REACT		TOTAL	FLEX. RIG.	
	y-DIR	z-DIR	z-DIR	y-DIR	y-DIR	z-DIR	y-DIR	z-DIR	STRESS	z-DIR	y-DIR
	M	M	KN- M	KN- M	KN	KN	KN/ M	KN/ M	KN/ M**2	KN- M**2	KN- M**2
*****	*****	*****	*****	*****	*****	*****	*****	*****	*****	*****	*****
1	2.6715E-04	1.6989E-05	90.482	293.49	57.103	61.924	32.791	19.136	2459.8	7.8279E+06	7.8279E+06
x(M)	0.0000	9.3000	5.4000	0.0000	0.0000	7.5000	4.2000	9.6000	0.0000	0.0000	0.0000
2	2.6715E-04	1.8218E-05	84.438	261.75	51.370	54.988	28.106	17.076	2207.6	7.8279E+06	7.8279E+06
x(M)	0.0000	9.6000	5.4000	0.0000	0.0000	7.5000	4.2000	9.9000	0.0000	0.0000	0.0000
3	2.6715E-04	1.7118E-05	88.626	275.24	55.242	58.889	31.340	18.126	2102.8	7.8279E+06	7.8279E+06
x(M)	0.0000	9.3000	5.4000	0.0000	0.0000	7.5000	4.2000	9.6000	0.0000	0.0000	0.0000
4	2.6217E-04	1.7139E-05	88.008	290.47	54.829	61.241	31.470	18.907	2900.6	7.8279E+06	7.8279E+06
x(M)	0.0000	9.3000	5.4000	0.0000	0.0000	7.5000	4.2000	9.6000	0.0000	0.0000	0.0000
5	2.6217E-04	1.8381E-05	82.144	259.05	49.318	54.330	26.980	16.893	2649.6	7.8279E+06	7.8279E+06
x(M)	0.0000	9.6000	5.4000	0.0000	0.0000	7.5000	4.2000	10.200	0.0000	0.0000	0.0000
6	2.6217E-04	1.7300E-05	86.131	272.03	52.968	58.142	30.019	17.902	2542.9	7.8279E+06	7.8279E+06
x(M)	0.0000	9.6000	5.4000	0.0000	0.0000	7.5000	4.2000	9.9000	0.0000	0.0000	0.0000
7	2.5718E-04	1.5339E-05	96.221	339.34	63.476	73.392	39.531	22.955	3509.5	7.8279E+06	7.8279E+06
x(M)	0.0000	8.7000	5.1000	0.0000	0.0000	7.2000	4.2000	9.0000	0.0000	0.0000	0.0000
8	2.5718E-04	1.5737E-05	93.083	319.32	60.284	69.207	36.806	21.390	3295.8	7.8279E+06	7.8279E+06
x(M)	0.0000	9.0000	5.1000	0.0000	0.0000	7.2000	4.2000	9.3000	0.0000	0.0000	0.0000
9	2.5718E-04	1.5261E-05	95.333	324.24	62.482	71.093	38.800	22.106	3162.9	7.8279E+06	7.8279E+06
x(M)	0.0000	9.0000	5.1000	0.0000	0.0000	7.2000	4.2000	9.0000	0.0000	0.0000	0.0000
Max.	2.6715E-04	1.8381E-05	96.221	339.34	63.476	73.392	39.531	22.955	3509.5	7.8279E+06	7.8279E+06
Pile N.	1	5	7	7	7	7	7	7	7	1	1

LOAD CASE : 15
CASE NAME : Load Case
LOAD TYPE : Special, Sp

REDUCTION FACTORS FOR CLOSELY-SPACED PILE GROUPS, COMBINED Y AND Z DIRECTIONS
ESTIMATED USING MOVEMENT IN THE DIRECTION OF PILE CAP DISPLACEMENTS

GROUP NO	P-FACTOR	Y-FACTOR
1	0.7198	1.0000
2	0.5338	1.0000
3	0.5845	1.0000
4	0.6860	1.0000
5	0.4962	1.0000
6	0.5450	1.0000
7	0.8661	1.0000
8	0.7164	1.0000
9	0.7574	1.0000

* TABLE L * COMPUTATION ON PILE CAP

* EQUIVALENT CONCENTRATED LOAD AT ORIGIN *

VERT. LOAD, KN	HOR. LOAD Y, KN	HOR. LOAD Z, KN
39821.0	1404.00	-1290.00
MOMENT X, KN- M	MOMENT Y, KN- M	MOMENT Z, KN- M
0.00000	-27913.0	-15054.0

* DISPLACEMENT OF GROUPED PILE FOUNDATION AT ORIGIN *

VERTICAL, M	HORIZONTAL Y, M	HORIZONTAL Z, M
2.11535E-03	7.28561E-04	-8.35224E-04
ANGLE ROT. X, RAD	ANGLE ROT. Y, RAD	ANGLE ROT. Z, RAD
-7.32790E-07	-1.22988E-04	-7.46827E-05

THE GLOBAL STRUCTURAL COORDINATE SYSTEM

* PILE TOP DISPLACEMENTS *

PILE GROUP	DISP. X, M	DISP. Y, M	DISP. Z, M	ROT. X, RAD	ROT. Y, RAD	ROT. Z, RAD
*****	*****	*****	*****	*****	*****	*****
1	1.8980E-03	7.3186E-04	-8.3852E-04	-7.3279E-07	-1.2299E-04	-7.4683E-05
2	1.5619E-03	7.3186E-04	-8.3522E-04	-7.3279E-07	-1.2299E-04	-7.4683E-05
3	1.2258E-03	7.3186E-04	-8.3193E-04	-7.3279E-07	-1.2299E-04	-7.4683E-05
4	2.4514E-03	7.2856E-04	-8.3852E-04	-7.3279E-07	-1.2299E-04	-7.4683E-05
5	2.1154E-03	7.2856E-04	-8.3522E-04	-7.3279E-07	-1.2299E-04	-7.4683E-05
6	1.7793E-03	7.2856E-04	-8.3193E-04	-7.3279E-07	-1.2299E-04	-7.4683E-05
7	3.0049E-03	7.2526E-04	-8.3852E-04	-7.3279E-07	-1.2299E-04	-7.4683E-05
8	2.6688E-03	7.2526E-04	-8.3522E-04	-7.3279E-07	-1.2299E-04	-7.4683E-05

APPALTATORE:

Consorzio

Soci



ITINERARIO NAPOLI – BARI

RADDOPPIO TRATTA APICE – ORSARA
I LOTTO FUNZIONALE APICE – HIRPINIA

PROGETTAZIONE:

Mandataria

Mandanti



PROGETTO ESECUTIVO

RELAZIONE DI CALCOLO FONDAZIONI PILE P1, P2, P21, P22, P23
E P24COMMESSA
IF28LOTTO
01CODIFICA
E ZZ CLDOCUMENTO
VI0403 002REV.
BFOGLIO
147 di
161

9	2.3327E-03	7.2526E-04	-8.3193E-04	-7.3279E-07	-1.2299E-04	-7.4683E-05
MINIMUM	1.2258E-03	7.2526E-04	-8.3852E-04	-7.3279E-07	-1.2299E-04	-7.4683E-05
Pile N.	3	7	1	1	1	1
MAXIMUM	3.0049E-03	7.3186E-04	-8.3193E-04	-7.3279E-07	-1.2299E-04	-7.4683E-05
Pile N.	7	1	3	1	1	1

* PILE TOP REACTIONS *

PILE GROUP	FOR. X, KN	FOR. Y, KN	FOR. Z, KN	MOM X, KN- M	MOM Y, KN- M	MOM Z, KN- M
1	3983.2	165.26	-152.67	-0.2592	288.27	393.24
2	3300.9	141.98	-128.02	-0.2592	240.92	348.69
3	2618.5	148.85	-133.99	-0.2592	250.90	361.93
4	5106.9	160.15	-148.51	-0.2592	281.03	382.77
5	4424.6	135.79	-122.69	-0.2592	231.00	335.65
6	3742.2	142.61	-128.65	-0.2592	241.14	348.94
7	6230.6	179.11	-169.25	-0.2592	318.57	416.56
8	5548.3	162.72	-151.18	-0.2592	284.81	386.50
9	4865.9	167.53	-155.04	-0.2592	290.34	395.28
MINIMUM	2618.5	135.79	-169.25	-0.2592	231.00	335.65
Pile N.	3	5	7	1	5	5
MAXIMUM	6230.6	179.11	-122.69	-0.2592	318.57	416.56
Pile N.	7	7	5	1	7	7

THE PILE COORDINATE SYSTEM (LOCAL AXES)

* PILE TOP DISPLACEMENTS *

PILE GROUP	DISP. x, M	DISP. y, M	DISP. z, M	ROT. x, RAD	ROT. y, RAD	ROT. z, RAD
1	1.8980E-03	7.3186E-04	-8.3852E-04	-7.3279E-07	-1.2299E-04	-7.4683E-05
2	1.5619E-03	7.3186E-04	-8.3522E-04	-7.3279E-07	-1.2299E-04	-7.4683E-05
3	1.2258E-03	7.3186E-04	-8.3193E-04	-7.3279E-07	-1.2299E-04	-7.4683E-05
4	2.4514E-03	7.2856E-04	-8.3852E-04	-7.3279E-07	-1.2299E-04	-7.4683E-05
5	2.1154E-03	7.2856E-04	-8.3522E-04	-7.3279E-07	-1.2299E-04	-7.4683E-05
6	1.7793E-03	7.2856E-04	-8.3193E-04	-7.3279E-07	-1.2299E-04	-7.4683E-05
7	3.0049E-03	7.2526E-04	-8.3852E-04	-7.3279E-07	-1.2299E-04	-7.4683E-05
8	2.6688E-03	7.2526E-04	-8.3522E-04	-7.3279E-07	-1.2299E-04	-7.4683E-05
9	2.3327E-03	7.2526E-04	-8.3193E-04	-7.3279E-07	-1.2299E-04	-7.4683E-05
MINIMUM	1.2258E-03	7.2526E-04	-8.3852E-04	-7.3279E-07	-1.2299E-04	-7.4683E-05
Pile N.	3	7	1	1	1	1
MAXIMUM	3.0049E-03	7.3186E-04	-8.3193E-04	-7.3279E-07	-1.2299E-04	-7.4683E-05
Pile N.	7	1	3	1	1	1

* PILE TOP REACTIONS *

PILE GROUP	AXIAL, KN	LAT. y, KN	LAT. z, KN	MOM x, KN- M	MOM y, KN- M	MOM z, KN- M
1	3983.2	165.26	-152.67	-0.2592	288.27	393.24
2	3300.9	141.98	-128.02	-0.2592	240.92	348.69
3	2618.5	148.85	-133.99	-0.2592	250.90	361.93
4	5106.9	160.15	-148.51	-0.2592	281.03	382.77
5	4424.6	135.79	-122.69	-0.2592	231.00	335.65
6	3742.2	142.61	-128.65	-0.2592	241.14	348.94
7	6230.6	179.11	-169.25	-0.2592	318.57	416.56
8	5548.3	162.72	-151.18	-0.2592	284.81	386.50
9	4865.9	167.53	-155.04	-0.2592	290.34	395.28
MINIMUM	2618.5	135.79	-169.25	-0.2592	231.00	335.65
Pile N.	3	5	7	1	5	5
MAXIMUM	6230.6	179.11	-122.69	-0.2592	318.57	416.56
Pile N.	7	7	5	1	7	7

PILE GROUP STRESS, KN/ M**2

1	3725.6
2	3147.0
3	2810.9
4	4323.1
5	3733.5
6	3397.8
7	5108.5
8	4588.7
9	4233.7
MINIMUM	2810.9
Pile N.	3
MAXIMUM	5108.5
Pile N.	7

* EFFECTS FOR LATERALLY LOADED PILE *

* MINIMUM VALUES AND LOCATIONS *

APPALDATTORE:

Consorzio

Soci



ITINERARIO NAPOLI – BARI

RADDOPPIO TRATTA APICE – ORSARA I LOTTO FUNZIONALE APICE – HIRPINIA

PROGETTAZIONE:

Mandataria

Mandanti



PROGETTO ESECUTIVO

RELAZIONE DI CALCOLO FONDAZIONI PILE P1, P2, P21, P22, P23 E P24

COMMESSA
IF28

LOTTO
01

CODIFICA
E ZZ CL

DOCUMENTO
VI0403 002

REV.
B

FOGLIO
148 di
161

PILE	DISPL. y-DIR M	DISPL. z-DIR M	MOMENT z-DIR KN- M	MOMENT y-DIR KN- M	SHEAR y-DIR KN	SHEAR z-DIR KN	SOIL REACT y-DIR KN/ M	SOIL REACT z-DIR KN/ M	TOTAL STRESS KN/ M**2	FLEX. RIG. z-DIR KN- M**2	FLEX. RIG. y-DIR KN- M**2
*****	*****	*****	*****	*****	*****	*****	*****	*****	*****	*****	*****
1	-1.6884E-05	-8.3852E-04	-393.24	-274.21	-68.626	-152.70	-21.951	-86.859	2254.0	7.8279E+06	7.8279E+06
x (M)	9.3000	0.0000	0.0000	5.1000	7.5000	0.0000	9.6000	4.2000	30.000	0.0000	0.0000
2	-1.9094E-05	-8.3522E-04	-348.69	-249.04	-58.634	-128.04	-19.152	-68.898	1867.9	7.8279E+06	7.8279E+06
x (M)	9.9000	0.0000	0.0000	5.4000	7.8000	0.0000	10.200	4.2000	30.000	0.0000	0.0000
3	-1.8321E-05	-8.3193E-04	-361.93	-254.97	-61.459	-134.00	-19.896	-73.538	1481.8	7.8279E+06	7.8279E+06
x (M)	9.9000	0.0000	0.0000	5.4000	7.8000	0.0000	10.200	4.2000	30.000	0.0000	0.0000
4	-1.7111E-05	-8.3852E-04	-382.77	-270.18	-66.652	-148.54	-21.300	-83.871	2889.9	7.8279E+06	7.8279E+06
x (M)	9.6000	0.0000	0.0000	5.1000	7.5000	0.0000	9.9000	4.2000	30.000	0.0000	0.0000
5	-1.9578E-05	-8.3522E-04	-335.65	-243.60	-56.115	-122.71	-18.469	-65.176	2503.8	7.8279E+06	7.8279E+06
x (M)	10.200	0.0000	0.0000	5.4000	7.8000	0.0000	10.500	4.2000	30.000	0.0000	0.0000
6	-1.8839E-05	-8.3193E-04	-348.94	-249.76	-59.047	-128.67	-19.235	-69.762	2117.7	7.8279E+06	7.8279E+06
x (M)	9.9000	0.0000	0.0000	5.4000	7.8000	0.0000	10.200	4.2000	30.000	0.0000	0.0000
7	-1.5685E-05	-8.3852E-04	-416.56	-290.87	-74.467	-169.28	-23.951	-99.802	3525.8	7.8279E+06	7.8279E+06
x (M)	9.0000	0.0000	0.0000	5.1000	7.2000	0.0000	9.3000	4.2000	30.000	0.0000	0.0000
8	-1.6773E-05	-8.3522E-04	-386.50	-273.06	-67.916	-151.21	-21.698	-86.335	3139.7	7.8279E+06	7.8279E+06
x (M)	9.3000	0.0000	0.0000	5.1000	7.5000	0.0000	9.6000	4.2000	30.000	0.0000	0.0000
9	-1.6456E-05	-8.3193E-04	-395.28	-276.81	-69.858	-155.07	-22.310	-89.587	2753.5	7.8279E+06	7.8279E+06
x (M)	9.3000	0.0000	0.0000	5.1000	7.5000	0.0000	9.6000	4.2000	30.000	0.0000	0.0000
Min.	-1.9578E-05	-8.3852E-04	-416.56	-290.87	-74.467	-169.28	-23.951	-99.802	1481.8	7.8279E+06	7.8279E+06
Pile N.	5	1	7	7	7	7	7	7	3	1	1

* MAXIMUM VALUES AND LOCATIONS *

PILE	DISPL. y-DIR M	DISPL. z-DIR M	MOMENT z-DIR KN- M	MOMENT y-DIR KN- M	SHEAR y-DIR KN	SHEAR z-DIR KN	SOIL REACT y-DIR KN/ M	SOIL REACT z-DIR KN/ M	TOTAL STRESS KN/ M**2	FLEX. RIG. z-DIR KN- M**2	FLEX. RIG. y-DIR KN- M**2
*****	*****	*****	*****	*****	*****	*****	*****	*****	*****	*****	*****
1	7.3186E-04	1.8305E-05	247.75	288.27	165.29	74.806	86.384	23.400	3725.6	7.8279E+06	7.8279E+06
x (M)	0.0000	9.3000	5.4000	0.0000	0.0000	7.5000	4.2000	9.6000	0.0000	0.0000	0.0000
2	7.3186E-04	2.0432E-05	225.08	240.92	142.00	64.070	69.111	20.143	3147.0	7.8279E+06	7.8279E+06
x (M)	0.0000	9.6000	5.7000	0.0000	0.0000	7.5000	4.2000	9.9000	0.0000	0.0000	0.0000
3	7.3186E-04	1.9614E-05	231.52	250.90	148.87	66.949	74.127	20.928	2810.9	7.8279E+06	7.8279E+06
x (M)	0.0000	9.6000	5.7000	0.0000	0.0000	7.5000	4.2000	9.9000	0.0000	0.0000	0.0000
4	7.2856E-04	1.8666E-05	242.87	281.03	160.19	73.223	82.969	22.892	4323.1	7.8279E+06	7.8279E+06
x (M)	0.0000	9.3000	5.4000	0.0000	0.0000	7.5000	4.2000	9.6000	0.0000	0.0000	0.0000
5	7.2856E-04	2.1080E-05	218.95	231.00	135.82	61.616	65.048	19.523	3733.5	7.8279E+06	7.8279E+06
x (M)	0.0000	9.9000	5.7000	0.0000	0.0000	7.8000	4.2000	10.200	0.0000	0.0000	0.0000
6	7.2856E-04	2.0197E-05	225.60	241.14	142.63	64.589	69.964	20.265	3397.8	7.8279E+06	7.8279E+06
x (M)	0.0000	9.6000	5.7000	0.0000	0.0000	7.5000	4.2000	9.9000	0.0000	0.0000	0.0000
7	7.2526E-04	1.7259E-05	260.12	318.57	179.16	82.505	97.961	25.911	5108.5	7.8279E+06	7.8279E+06
x (M)	0.0000	9.0000	5.4000	0.0000	0.0000	7.2000	4.2000	9.0000	0.0000	0.0000	0.0000
8	7.2526E-04	1.8288E-05	245.32	284.81	162.76	74.460	85.368	23.264	4588.7	7.8279E+06	7.8279E+06
x (M)	0.0000	9.3000	5.4000	0.0000	0.0000	7.2000	4.2000	9.6000	0.0000	0.0000	0.0000
9	7.2526E-04	1.7839E-05	249.77	290.34	167.57	76.383	89.050	23.893	4233.7	7.8279E+06	7.8279E+06
x (M)	0.0000	9.0000	5.4000	0.0000	0.0000	7.2000	4.2000	9.3000	0.0000	0.0000	0.0000
Max.	7.3186E-04	2.1080E-05	260.12	318.57	179.16	82.505	97.961	25.911	5108.5	7.8279E+06	7.8279E+06
Pile N.	1	5	7	7	7	7	7	7	7	1	1

LOAD CASE : 16
CASE NAME : Load Case
LOAD TYPE : Special, Sp

REDUCTION FACTORS FOR CLOSELY-SPACED PILE GROUPS, COMBINED Y AND Z DIRECTIONS
ESTIMATED USING MOVEMENT IN THE DIRECTION OF PILE CAP DISPLACEMENTS

GROUP NO	P-FACTOR	Y-FACTOR
1	0.8454	1.0000
2	0.5724	1.0000
3	0.5845	1.0000
4	0.7882	1.0000
5	0.4962	1.0000
6	0.5043	1.0000
7	0.8661	1.0000
8	0.6021	1.0000
9	0.6141	1.0000

* TABLE L * COMPUTATION ON PILE CAP

* EQUIVALENT CONCENTRATED LOAD AT ORIGIN *

VERT. LOAD, KN	HOR. LOAD Y, KN	HOR. LOAD Z, KN
40569.0	3786.00	-1067.00
MOMENT X, KN- M	MOMENT Y, KN- M	MOMENT Z, KN- M

APPALTATORE:

Consorzio

Soci



PROGETTAZIONE:

Mandataria

Mandanti



ITINERARIO NAPOLI – BARI

RADDOPPIO TRATTA APICE – ORSARA
I LOTTO FUNZIONALE APICE – HIRPINIA

PROGETTO ESECUTIVO

RELAZIONE DI CALCOLO FONDAZIONI PILE P1, P2, P21, P22, P23
E P24

COMMESSA	LOTTO	CODIFICA	DOCUMENTO	REV.	FOGLIO
IF28	01	E ZZ CL	VI0403 002	B	149 di 161

-361.000 -17067.5 -44997.0

* DISPLACEMENT OF GROUPED PILE FOUNDATION AT ORIGIN *

VERTICAL , M	HORIZONTAL Y, M	HORIZONTAL Z, M
2.16522E-03	2.23587E-03	-6.89376E-04
ANGLE ROT. X,RAD	ANGLE ROT. Y,RAD	ANGLE ROT. Z,RAD
-8.25881E-07	-8.17283E-05	-2.22622E-04

THE GLOBAL STRUCTURAL COORDINATE SYSTEM

* PILE TOP DISPLACEMENTS *

PILE GROUP	DISP. X, M	DISP. Y, M	DISP. Z, M	ROT. X,RAD	ROT. Y,RAD	ROT. Z,RAD
1	2.7992E-03	2.2396E-03	-6.9309E-04	-8.2588E-07	-8.1728E-05	-2.2262E-04
2	1.7974E-03	2.2396E-03	-6.8938E-04	-8.2588E-07	-8.1728E-05	-2.2262E-04
3	7.9565E-04	2.2396E-03	-6.8566E-04	-8.2588E-07	-8.1728E-05	-2.2262E-04
4	3.1670E-03	2.2359E-03	-6.9309E-04	-8.2588E-07	-8.1728E-05	-2.2262E-04
5	2.1652E-03	2.2359E-03	-6.8938E-04	-8.2588E-07	-8.1728E-05	-2.2262E-04
6	1.1634E-03	2.2359E-03	-6.8566E-04	-8.2588E-07	-8.1728E-05	-2.2262E-04
7	3.5348E-03	2.2322E-03	-6.9309E-04	-8.2588E-07	-8.1728E-05	-2.2262E-04
8	2.5330E-03	2.2322E-03	-6.8938E-04	-8.2588E-07	-8.1728E-05	-2.2262E-04
9	1.5312E-03	2.2322E-03	-6.8566E-04	-8.2588E-07	-8.1728E-05	-2.2262E-04
MINIMUM	7.9565E-04	2.2322E-03	-6.9309E-04	-8.2588E-07	-8.1728E-05	-2.2262E-04
Pile N.	3	7	1	1	1	1
MAXIMUM	3.5348E-03	2.2396E-03	-6.8566E-04	-8.2588E-07	-8.1728E-05	-2.2262E-04
Pile N.	7	1	3	1	1	1

* PILE TOP REACTIONS *

PILE GROUP	FOR. X, KN	FOR. Y, KN	FOR. Z, KN	MOM X, KN- M	MOM Y, KN- M	MOM Z, KN- M
1	5813.1	501.50	-142.97	-0.2921	312.69	1187.0
2	3779.1	388.14	-108.68	-0.2921	242.10	955.22
3	1745.1	393.76	-109.37	-0.2921	241.89	965.21
4	6559.8	481.79	-137.47	-0.2921	302.88	1150.0
5	4525.8	354.64	-99.162	-0.2921	222.84	885.57
6	2491.8	358.79	-99.496	-0.2921	221.98	892.76
7	7143.3	505.51	-144.86	-0.2921	316.43	1192.5
8	5272.5	398.21	-112.18	-0.2921	249.52	974.65
9	3238.5	403.66	-112.81	-0.2921	249.14	984.19
MINIMUM	1745.1	354.64	-144.86	-0.2921	221.98	885.57
Pile N.	3	5	7	1	6	5
MAXIMUM	7143.3	505.51	-99.162	-0.2921	316.43	1192.5
Pile N.	7	7	5	1	7	7

THE PILE COORDINATE SYSTEM (LOCAL AXES)

* PILE TOP DISPLACEMENTS *

PILE GROUP	DISP. x, M	DISP. y, M	DISP. z, M	ROT. x,RAD	ROT. y,RAD	ROT. z,RAD
1	2.7992E-03	2.2396E-03	-6.9309E-04	-8.2588E-07	-8.1728E-05	-2.2262E-04
2	1.7974E-03	2.2396E-03	-6.8938E-04	-8.2588E-07	-8.1728E-05	-2.2262E-04
3	7.9565E-04	2.2396E-03	-6.8566E-04	-8.2588E-07	-8.1728E-05	-2.2262E-04
4	3.1670E-03	2.2359E-03	-6.9309E-04	-8.2588E-07	-8.1728E-05	-2.2262E-04
5	2.1652E-03	2.2359E-03	-6.8938E-04	-8.2588E-07	-8.1728E-05	-2.2262E-04
6	1.1634E-03	2.2359E-03	-6.8566E-04	-8.2588E-07	-8.1728E-05	-2.2262E-04
7	3.5348E-03	2.2322E-03	-6.9309E-04	-8.2588E-07	-8.1728E-05	-2.2262E-04
8	2.5330E-03	2.2322E-03	-6.8938E-04	-8.2588E-07	-8.1728E-05	-2.2262E-04
9	1.5312E-03	2.2322E-03	-6.8566E-04	-8.2588E-07	-8.1728E-05	-2.2262E-04
MINIMUM	7.9565E-04	2.2322E-03	-6.9309E-04	-8.2588E-07	-8.1728E-05	-2.2262E-04
Pile N.	3	7	1	1	1	1
MAXIMUM	3.5348E-03	2.2396E-03	-6.8566E-04	-8.2588E-07	-8.1728E-05	-2.2262E-04
Pile N.	7	1	3	1	1	1

* PILE TOP REACTIONS *

PILE GROUP	AXIAL, KN	LAT. y, KN	LAT. z, KN	MOM x, KN- M	MOM y, KN- M	MOM z, KN- M
1	5813.1	501.50	-142.97	-0.2921	312.69	1187.0
2	3779.1	388.14	-108.68	-0.2921	242.10	955.22
3	1745.1	393.76	-109.37	-0.2921	241.89	965.21
4	6559.8	481.79	-137.47	-0.2921	302.88	1150.0
5	4525.8	354.64	-99.162	-0.2921	222.84	885.57
6	2491.8	358.79	-99.496	-0.2921	221.98	892.76
7	7143.3	505.51	-144.86	-0.2921	316.43	1192.5

APPALTATORE: Consorzio Soci 	ITINERARIO NAPOLI – BARI RADDOPPIO TRATTA APICE – ORSARA I LOTTO FUNZIONALE APICE – HIRPINIA
PROGETTAZIONE: Mandataria Mandanti 	
PROGETTO ESECUTIVO RELAZIONE DI CALCOLO FONDAZIONI PILE P1, P2, P21, P22, P23 E P24	COMMESSA IF28 LOTTO 01 CODIFICA E ZZ CL DOCUMENTO VI0403 002 REV. B FOGLIO 150 di 161

8	5272.5	398.21	-112.18	-0.2921	249.52	974.65
9	3238.5	403.66	-112.81	-0.2921	249.14	984.19
MINIMUM Pile N.	1745.1	354.64	-144.86	-0.2921	221.98	885.57
MAXIMUM Pile N.	7143.3	505.51	-99.162	-0.2921	316.43	1192.5

PILE GROUP STRESS, KN/ M**2

1	6994.1
2	5112.6
3	3990.6
4	7301.3
5	5317.1
6	4186.5
7	7765.9
8	6020.1
9	4896.7
MINIMUM Pile N.	3990.6
MAXIMUM Pile N.	7765.9

* EFFECTS FOR LATERALLY LOADED PILE *

* MINIMUM VALUES AND LOCATIONS *

PILE	DISPL.		MOMENT		SHEAR		SOIL REACT		TOTAL STRESS	FLEX. RIG.	
	y-Dir	z-Dir	z-Dir	y-Dir	y-Dir	z-Dir	y-Dir	z-Dir		z-Dir	y-Dir
	M	M	KN- M	KN- M	KN	KN	KN/ M	KN/ M	KN/ M**2	KN- M**2	KN- M**2
1	-5.2436E-05	-6.9309E-04	-1187.0	-216.30	-195.30	-143.00	-61.596	-63.423	3289.5	7.8279E+06	7.8279E+06
x(M)	9.6000	0.0000	0.0000	5.4000	7.8000	0.0000	10.800	4.2000	30.000	0.0000	0.0000
2	-6.1816E-05	-6.8938E-04	-955.22	-177.61	-141.70	-108.70	-41.278	-43.682	2138.5	7.8279E+06	7.8279E+06
x(M)	10.500	0.0000	0.0000	5.7000	8.4000	0.0000	10.800	4.2000	30.000	0.0000	0.0000
3	-6.1235E-05	-6.8566E-04	-965.21	-178.06	-143.42	-109.38	-41.967	-44.172	987.50	7.8279E+06	7.8279E+06
x(M)	10.500	0.0000	0.0000	5.7000	8.4000	0.0000	10.800	4.2000	30.000	0.0000	0.0000
4	-5.3778E-05	-6.9309E-04	-1150.0	-211.57	-188.80	-137.51	-60.955	-60.201	3712.1	7.8279E+06	7.8279E+06
x(M)	9.6000	0.0000	0.0000	5.4000	7.8000	0.0000	10.800	4.2000	30.000	0.0000	0.0000
5	-6.5130E-05	-6.8938E-04	-885.57	-167.53	-128.63	-99.182	-36.385	-38.634	2561.1	7.8279E+06	7.8279E+06
x(M)	10.800	0.0000	0.0000	6.0000	8.4000	0.0000	10.800	4.2000	30.000	0.0000	0.0000
6	-6.4657E-05	-6.8566E-04	-892.76	-167.60	-129.91	-99.507	-36.900	-38.913	1410.1	7.8279E+06	7.8279E+06
x(M)	10.800	0.0000	0.0000	5.7000	8.4000	0.0000	10.800	4.2000	30.000	0.0000	0.0000
7	-5.1732E-05	-6.9309E-04	-1192.5	-218.17	-196.98	-144.90	-61.531	-64.680	4042.3	7.8279E+06	7.8279E+06
x(M)	9.6000	0.0000	0.0000	5.4000	7.8000	0.0000	10.800	4.2000	30.000	0.0000	0.0000
8	-6.0466E-05	-6.8938E-04	-974.65	-181.53	-146.67	-112.21	-42.947	-45.691	2983.6	7.8279E+06	7.8279E+06
x(M)	10.500	0.0000	0.0000	5.7000	8.1000	0.0000	10.800	4.2000	30.000	0.0000	0.0000
9	-5.9860E-05	-6.8566E-04	-984.19	-181.87	-148.66	-112.82	-43.587	-46.151	1832.6	7.8279E+06	7.8279E+06
x(M)	10.500	0.0000	0.0000	5.7000	8.1000	0.0000	10.800	4.2000	30.000	0.0000	0.0000
Min. Pile N.	5	1	7	7	7	7	1	7	3	1	1

* MAXIMUM VALUES AND LOCATIONS *

PILE	DISPL.		MOMENT		SHEAR		SOIL REACT		TOTAL STRESS	FLEX. RIG.	
	y-Dir	z-Dir	z-Dir	y-Dir	y-Dir	z-Dir	y-Dir	z-Dir		z-Dir	y-Dir
	M	M	KN- M	KN- M	KN	KN	KN/ M	KN/ M	KN/ M**2	KN- M**2	KN- M**2
1	2.2396E-03	1.5770E-05	708.40	312.69	501.63	59.059	215.95	18.178	6994.1	7.8279E+06	7.8279E+06
x(M)	0.0000	9.6000	5.7000	0.0000	0.0000	7.5000	4.2000	10.800	0.0000	0.0000	0.0000
2	2.2396E-03	1.8411E-05	583.02	242.10	388.21	42.842	150.16	12.227	5112.6	7.8279E+06	7.8279E+06
x(M)	0.0000	10.500	6.0000	0.0000	0.0000	8.1000	4.2000	10.800	0.0000	0.0000	0.0000
3	2.2396E-03	1.8104E-05	587.63	241.89	393.79	43.185	152.94	12.339	3990.6	7.8279E+06	7.8279E+06
x(M)	0.0000	10.500	6.0000	0.0000	0.0000	8.1000	4.2000	10.800	0.0000	0.0000	0.0000
4	2.2359E-03	1.6236E-05	693.05	302.88	481.94	57.159	204.59	18.049	7301.3	7.8279E+06	7.8279E+06
x(M)	0.0000	9.6000	5.7000	0.0000	0.0000	7.8000	4.2000	10.800	0.0000	0.0000	0.0000
5	2.2359E-03	1.9431E-05	549.68	222.84	354.72	38.970	132.61	10.855	5317.1	7.8279E+06	7.8279E+06
x(M)	0.0000	10.800	6.0000	0.0000	0.0000	8.4000	4.2000	10.800	0.0000	0.0000	0.0000
6	2.2359E-03	1.9152E-05	553.10	221.98	358.83	39.992	134.54	10.930	4186.5	7.8279E+06	7.8279E+06
x(M)	0.0000	10.800	6.0000	0.0000	0.0000	8.4000	4.2000	10.800	0.0000	0.0000	0.0000
7	2.2321E-03	1.5607E-05	711.34	316.43	505.67	59.942	219.28	18.278	7765.9	7.8279E+06	7.8279E+06
x(M)	0.0000	9.6000	5.7000	0.0000	0.0000	7.5000	4.2000	10.500	0.0000	0.0000	0.0000
8	2.2321E-03	1.8042E-05	593.25	249.52	398.31	44.566	156.36	12.756	6020.1	7.8279E+06	7.8279E+06
x(M)	0.0000	10.500	6.0000	0.0000	0.0000	8.1000	4.2000	10.500	0.0000	0.0000	0.0000
9	2.2321E-03	1.7731E-05	597.89	249.14	403.72	44.859	159.07	12.869	4896.7	7.8279E+06	7.8279E+06
x(M)	0.0000	10.500	5.7000	0.0000	0.0000	8.1000	4.2000	10.500	0.0000	0.0000	0.0000
Max. Pile N.	1	5	7	7	7	7	7	7	7	1	1

APPALTATORE: Consorzio  Soci  	ITINERARIO NAPOLI – BARI RADDOPPIO TRATTA APICE – ORSARA I LOTTO FUNZIONALE APICE – HIRPINIA
PROGETTAZIONE: Mandataria  Mandanti  	
PROGETTO ESECUTIVO RELAZIONE DI CALCOLO FONDAZIONI PILE P1, P2, P21, P22, P23 E P24	COMMESSA LOTTO CODIFICA DOCUMENTO REV. FOGLIO IF28 01 E ZZ CL VI0403 002 B 151 di 161

***** LOAD CASES RESULTS *****

LOAD CASE : 1

* TABLE L * COMPUTATION ON PILE CAP

* EQUIVALENT CONCENTRATED LOAD AT ORIGIN *

LOAD X, KN	LOAD Y, KN	LOAD Z, KN	MOM X, KN- M	MOM Y, KN- M	MOM Z, KN- M
23727.0	10828.4	-2743.40	-158.000	-30134.5	-1.08980E+05

* DISPLACEMENT OF GROUPED PILE FOUNDATION AT ORIGIN *

DISP X, M	DISP Y, M	DISP Z, M	ROT X,RAD	ROT Y,RAD	ROT Z,RAD
1.34385E-03	7.87064E-03	-2.07376E-03	1.33807E-05	-1.68150E-04	-5.76500E-04

* PILE TOP DISPLACEMENTS, GLOBAL *

	DISP. X, M	DISP. Y, M	DISP. Z, M	ROT. X,RAD	ROT. Y,RAD	ROT. Z,RAD
MINIMUM	-2.0071E-03	7.8104E-03	-2.1340E-03	1.3381E-05	-1.6815E-04	-5.7650E-04
Pile N.	3	1	3	1	1	1
MAXIMUM	4.6948E-03	7.9309E-03	-2.0135E-03	1.3381E-05	-1.6815E-04	-5.7650E-04
Pile N.	7	7	1	1	1	1

* PILE TOP REACTIONS, GLOBAL *

	FOR. X, KN	FOR. Y, KN	FOR. Z, KN	MOM X, KN- M	MOM Y, KN- M	MOM Z, KN- M
MINIMUM	-4168.9	1013.0	-352.92	4.7323	720.32	2943.8
Pile N.	3	5	7	1	5	5
MAXIMUM	8765.7	1456.5	-256.78	4.7323	920.51	3951.3
Pile N.	7	7	5	1	7	7

* PILE TOP DISPLACEMENTS, LOCAL *

	DISP. x, M	DISP. y, M	DISP. z, M	ROT. x,RAD	ROT. y,RAD	ROT. z,RAD
MINIMUM	-2.0071E-03	7.8104E-03	-2.1340E-03	1.3381E-05	-1.6815E-04	-5.7650E-04
Pile N.	3	1	3	1	1	1
MAXIMUM	4.6948E-03	7.9309E-03	-2.0135E-03	1.3381E-05	-1.6815E-04	-5.7650E-04
Pile N.	7	7	1	1	1	1

* PILE TOP REACTIONS, LOCAL *

	AXIAL, KN	LAT. y, KN	LAT. z, KN	MOM x, KN- M	MOM y, KN- M	MOM z, KN- M
MINIMUM	-4168.9	1013.0	-352.92	4.7323	720.32	2943.8
Pile N.	3	5	7	1	5	5
MAXIMUM	8765.7	1456.5	-256.78	4.7323	920.51	3951.3
Pile N.	7	7	5	1	7	7

* EFFECTS FOR Laterally LOADED PILE *

PILE	DISPL. y-DIR M	DISPL. z-DIR M	MOMENT z-DIR KN- M	MOMENT y-DIR KN- M	SHEAR z-DIR KN	SHEAR y-DIR KN	SOIL REACT y-DIR KN/ M	SOIL REACT z-DIR KN/ M	TOTAL STRESS KN/ M**2
Min.	-1.9106E-04	-2.1340E-03	-3951.3	-476.92	-436.88	-353.07	-103.97	-111.45	613.60
Pile N.	7	3	7	7	7	7	7	7	9
Max.	7.9309E-03	5.0141E-05	1894.4	920.51	1457.1	109.36	452.35	25.973	1.7205E+04
Pile N.	7	9	7	7	7	7	7	7	7

LOAD CASE : 2

* TABLE L * COMPUTATION ON PILE CAP

* EQUIVALENT CONCENTRATED LOAD AT ORIGIN *

LOAD X, KN	LOAD Y, KN	LOAD Z, KN	MOM X, KN- M	MOM Y, KN- M	MOM Z, KN- M
29884.0	-10137.6	2693.90	109.000	30734.5	1.00646E+05

* DISPLACEMENT OF GROUPED PILE FOUNDATION AT ORIGIN *

DISP X, M	DISP Y, M	DISP Z, M	ROT X,RAD	ROT Y,RAD	ROT Z,RAD
1.69145E-03	-7.21107E-03	2.00934E-03	1.77499E-05	1.69349E-04	5.40137E-04

* PILE TOP DISPLACEMENTS, GLOBAL *

	DISP. X, M	DISP. Y, M	DISP. Z, M	ROT. X,RAD	ROT. Y,RAD	ROT. Z,RAD
MINIMUM	-1.5012E-03	-7.2909E-03	1.9295E-03	1.7750E-05	1.6935E-04	5.4014E-04
Pile N.	7	1	3	1	1	1
MAXIMUM	4.8841E-03	-7.1312E-03	2.0892E-03	1.7750E-05	1.6935E-04	5.4014E-04
Pile N.	3	7	1	1	1	1

* PILE TOP REACTIONS, GLOBAL *

	FOR. X, KN	FOR. Y, KN	FOR. Z, KN	MOM X, KN- M	MOM Y, KN- M	MOM Z, KN- M
MINIMUM	-3146.5	-1368.4	252.28	6.2775	-870.32	-3670.6
Pile N.	7	3	5	1	3	3
MAXIMUM	9030.5	-948.27	341.35	6.2775	-693.52	-2721.1
Pile N.	3	5	3	1	5	5

* PILE TOP DISPLACEMENTS, LOCAL *

	DISP. x, M	DISP. y, M	DISP. z, M	ROT. x,RAD	ROT. y,RAD	ROT. z,RAD
--	------------	------------	------------	------------	------------	------------

APPALTATORE: Consorzio Soci   		ITINERARIO NAPOLI – BARI RADDOPPIO TRATTA APICE – ORSARA I LOTTO FUNZIONALE APICE – HIRPINIA					
PROGETTAZIONE: Mandataria Mandanti   							
PROGETTO ESECUTIVO RELAZIONE DI CALCOLO FONDAZIONI PILE P1, P2, P21, P22, P23 E P24						COMMESSA IF28	LOTTO 01

```

*****
MINIMUM -1.5012E-03 -7.2909E-03 1.9295E-03 1.7750E-05 1.6935E-04 5.4014E-04
Pile N. 7 1 3 1 1 1
MAXIMUM 4.8841E-03 -7.1312E-03 2.0892E-03 1.7750E-05 1.6935E-04 5.4014E-04
Pile N. 3 7 1 1 1 1

* PILE TOP REACTIONS, LOCAL *
AXIAL, KN LAT. y, KN LAT. z, KN MOM x, KN- M MOM y, KN- M MOM z, KN- M
*****
MINIMUM -3146.5 -1368.4 252.28 6.2775 -870.32 -3670.6
Pile N. 7 3 5 1 3 3
MAXIMUM 9030.5 -948.27 341.35 6.2775 -693.52 -2721.1
Pile N. 3 5 3 1 5 5

* EFFECTS FOR LATERALLY LOADED PILE *
PILE DISPL. DISPL. MOMENT MOMENT SHEAR SHEAR SOIL REACT SOIL REACT TOTAL
y-DIR z-DIR z-DIR y-DIR y-DIR z-DIR y-DIR z-DIR STRESS
M M KN- M KN- M KN KN/ M KN/ M KN/ M**2
*****
Min. -7.2909E-03 -5.0240E-05 -1770.9 -870.32 -1369.0 -107.84 -429.84 -26.112 28.811
Pile N. 1 7 3 3 3 3 3 3 1
Max. 1.7828E-04 2.0892E-03 3670.6 464.29 414.08 341.50 100.91 109.50 1.6495E+04
Pile N. 2 1 3 3 3 3 3 3 3

LOAD CASE : 3

* TABLE L * COMPUTATION ON PILE CAP

* EQUIVALENT CONCENTRATED LOAD AT ORIGIN *
LOAD X, KN LOAD Y, KN LOAD Z, KN MOM X, KN- M MOM Y, KN- M MOM Z, KN- M
24213.0 3367.10 -9111.30 -363.000 -1.00998E+05 -33681.4

* DISPLACEMENT OF GROUPED PILE FOUNDATION AT ORIGIN *
DISP X, M DISP Y, M DISP Z, M ROT X,RAD ROT Y,RAD ROT Z,RAD
1.35285E-03 2.36564E-03 -6.42540E-03 -2.24592E-05 -5.16408E-04 -1.85867E-04

* PILE TOP DISPLACEMENTS, GLOBAL *
DISP. X, M DISP. Y, M DISP. Z, M ROT. X,RAD ROT. Y,RAD ROT. Z,RAD
*****
MINIMUM -1.8074E-03 2.2646E-03 -6.5265E-03 -2.2459E-05 -5.1641E-04 -1.8587E-04
Pile N. 3 7 1 1 1 1
MAXIMUM 4.5131E-03 2.4667E-03 -6.3243E-03 -2.2459E-05 -5.1641E-04 -1.8587E-04
Pile N. 7 1 3 1 1 1

* PILE TOP REACTIONS, GLOBAL *
FOR. X, KN FOR. Y, KN FOR. Z, KN MOM X, KN- M MOM Y, KN- M MOM Z, KN- M
*****
MINIMUM -3765.3 315.98 -1236.4 -7.9430 2367.5 886.42
Pile N. 3 5 7 1 5 5
MAXIMUM 8511.6 423.65 -850.76 -7.9430 3236.0 1097.0
Pile N. 7 7 5 1 7 7

* PILE TOP DISPLACEMENTS, LOCAL *
DISP. x, M DISP. y, M DISP. z, M ROT. x,RAD ROT. y,RAD ROT. z,RAD
*****
MINIMUM -1.8074E-03 2.2646E-03 -6.5265E-03 -2.2459E-05 -5.1641E-04 -1.8587E-04
Pile N. 3 7 1 1 1 1
MAXIMUM 4.5131E-03 2.4667E-03 -6.3243E-03 -2.2459E-05 -5.1641E-04 -1.8587E-04
Pile N. 7 1 3 1 1 1

* PILE TOP REACTIONS, LOCAL *
AXIAL, KN LAT. y, KN LAT. z, KN MOM x, KN- M MOM y, KN- M MOM z, KN- M
*****
MINIMUM -3765.3 315.98 -1236.4 -7.9430 2367.5 886.42
Pile N. 3 5 7 1 5 5
MAXIMUM 8511.6 423.65 -850.76 -7.9430 3236.0 1097.0
Pile N. 7 7 5 1 7 7





* EFFECTS FOR LATERALLY LOADED PILE *
PILE DISPL. DISPL. MOMENT MOMENT SHEAR SHEAR SOIL REACT SOIL REACT TOTAL
y-DIR z-DIR z-DIR y-DIR y-DIR z-DIR y-DIR z-DIR STRESS
M M KN- M KN- M KN KN/ M KN/ M KN/ M**2
*****
Min. -6.1266E-05 -6.5265E-03 -1097.0 -1612.5 -131.78 -1236.9 -32.845 -396.19 167.26
Pile N. 3 1 7 7 7 7 7 7 1
Max. 2.4667E-03 1.6167E-04 558.62 3236.0 423.83 381.33 136.35 95.144 1.5129E+04
Pile N. 1 4 7 7 7 7 7 7 7

LOAD CASE : 4

* TABLE L * COMPUTATION ON PILE CAP

* EQUIVALENT CONCENTRATED LOAD AT ORIGIN *
LOAD X, KN LOAD Y, KN LOAD Z, KN MOM X, KN- M MOM Y, KN- M MOM Z, KN- M
29884.0 -2824.80 8980.40 362.000 1.02448E+05 27465.9

```

APPALTATORE: Consorzio Soci   	ITINERARIO NAPOLI – BARI RADDOPPIO TRATTA APICE – ORSARA I LOTTO FUNZIONALE APICE – HIRPINIA
PROGETTAZIONE: Mandataria Mandanti   	
PROGETTO ESECUTIVO RELAZIONE DI CALCOLO FONDAZIONI PILE P1, P2, P21, P22, P23 E P24	
	COMMESSA LOTTO CODIFICA DOCUMENTO REV. FOGLIO IF28 01 E ZZ CL VI0403 002 B 153 di 161

* DISPLACEMENT OF GROUPED PILE FOUNDATION AT ORIGIN *

DISP X, M	DISP Y, M	DISP Z, M	ROT X,RAD	ROT Y,RAD	ROT Z,RAD
1.68549E-03	-1.96906E-03	6.35348E-03	-7.17255E-06	5.28294E-04	1.56571E-04

* PILE TOP DISPLACEMENTS, GLOBAL *

	DISP. X, M	DISP. Y, M	DISP. Z, M	ROT. X,RAD	ROT. Y,RAD	ROT. Z,RAD
MINIMUM	-1.3964E-03	-2.0013E-03	6.3212E-03	-7.1725E-06	5.2829E-04	1.5657E-04
Pile N.	7	7	1	1	1	1
MAXIMUM	4.7674E-03	-1.9368E-03	6.3858E-03	-7.1725E-06	5.2829E-04	1.5657E-04
Pile N.	3	1	3	1	1	1

* PILE TOP REACTIONS, GLOBAL *

	FOR. X, KN	FOR. Y, KN	FOR. Z, KN	MOM X, KN- M	MOM Y, KN- M	MOM Z, KN- M
MINIMUM	-2934.6	-368.72	838.88	-2.5367	-3108.7	-957.07
Pile N.	7	3	5	1	3	3
MAXIMUM	8867.2	-264.65	1206.0	-2.5367	-2302.6	-738.55
Pile N.	3	5	3	1	5	5

* PILE TOP DISPLACEMENTS, LOCAL *

	DISP. x, M	DISP. y, M	DISP. z, M	ROT. x,RAD	ROT. y,RAD	ROT. z,RAD
MINIMUM	-1.3964E-03	-2.0013E-03	6.3212E-03	-7.1725E-06	5.2829E-04	1.5657E-04
Pile N.	7	7	1	1	1	1
MAXIMUM	4.7674E-03	-1.9368E-03	6.3858E-03	-7.1725E-06	5.2829E-04	1.5657E-04
Pile N.	3	1	3	1	1	1

* PILE TOP REACTIONS, LOCAL *

	AXIAL, KN	LAT. y, KN	LAT. z, KN	MOM x, KN- M	MOM y, KN- M	MOM z, KN- M
MINIMUM	-2934.6	-368.72	838.88	-2.5367	-3108.7	-957.07
Pile N.	7	3	5	1	3	3
MAXIMUM	8867.2	-264.65	1206.0	-2.5367	-2302.6	-738.55
Pile N.	3	5	3	1	5	5

* EFFECTS FOR LATERALLY LOADED PILE *

PILE	DISPL. y-DIR	DISPL. z-DIR	MOMENT z-DIR	MOMENT y-DIR	SHEAR y-DIR	SHEAR z-DIR	SOIL REACT y-DIR	SOIL REACT z-DIR	TOTAL STRESS
	M	M	KN- M	KN- M	KN	KN	KN/ M	KN/ M	KN/ M**2
Min.	-2.0013E-03	-1.5957E-04	-482.83	-3108.7	-368.89	-376.30	-119.21	-94.880	16.017
Pile N.	7	6	3	3	3	3	3	3	9
Max.	5.0059E-05	6.3858E-03	957.07	1590.2	114.44	1206.5	28.873	391.00	1.4835E+04
Pile N.	9	3	3	3	3	3	3	3	3

LOAD CASE : 5

* TABLE L * COMPUTATION ON PILE CAP

* EQUIVALENT CONCENTRATED LOAD AT ORIGIN *

LOAD X, KN	LOAD Y, KN	LOAD Z, KN	MOM X, KN- M	MOM Y, KN- M	MOM Z, KN- M
38962.0	-3041.50	2693.90	109.000	30893.0	30207.7

* DISPLACEMENT OF GROUPED PILE FOUNDATION AT ORIGIN *

DISP X, M	DISP Y, M	DISP Z, M	ROT X,RAD	ROT Y,RAD	ROT Z,RAD
2.07499E-03	-1.70799E-03	1.56430E-03	1.85683E-06	1.54070E-04	1.55618E-04

* PILE TOP DISPLACEMENTS, GLOBAL *

	DISP. X, M	DISP. Y, M	DISP. Z, M	ROT. X,RAD	ROT. Y,RAD	ROT. Z,RAD
MINIMUM	6.8140E-04	-1.7163E-03	1.5559E-03	1.8568E-06	1.5407E-04	1.5562E-04
Pile N.	7	1	3	1	1	1
MAXIMUM	3.4686E-03	-1.6996E-03	1.5727E-03	1.8568E-06	1.5407E-04	1.5562E-04
Pile N.	3	7	1	1	1	1

* PILE TOP REACTIONS, GLOBAL *

	FOR. X, KN	FOR. Y, KN	FOR. Z, KN	MOM X, KN- M	MOM Y, KN- M	MOM Z, KN- M
MINIMUM	1513.1	-403.05	248.93	0.6567	-834.56	-981.80
Pile N.	7	3	5	1	3	3
MAXIMUM	7050.7	-281.58	352.91	0.6567	-624.47	-730.13
Pile N.	3	5	3	1	5	5

* PILE TOP DISPLACEMENTS, LOCAL *

	DISP. x, M	DISP. y, M	DISP. z, M	ROT. x,RAD	ROT. y,RAD	ROT. z,RAD
MINIMUM	6.8140E-04	-1.7163E-03	1.5559E-03	1.8568E-06	1.5407E-04	1.5562E-04
Pile N.	7	1	3	1	1	1
MAXIMUM	3.4686E-03	-1.6996E-03	1.5727E-03	1.8568E-06	1.5407E-04	1.5562E-04
Pile N.	3	7	1	1	1	1

* PILE TOP REACTIONS, LOCAL *

	AXIAL, KN	LAT. y, KN	LAT. z, KN	MOM x, KN- M	MOM y, KN- M	MOM z, KN- M
MINIMUM	1513.1	-403.05	248.93	0.6567	-834.56	-981.80
Pile N.	7	3	5	1	3	3

APPALTATORE:

Consorzio

Soci



ITINERARIO NAPOLI – BARI

PROGETTAZIONE:

Mandataria

Mandanti



RADDOPPIO TRATTA APICE – ORSARA
I LOTTO FUNZIONALE APICE – HIRPINIA

PROGETTO ESECUTIVO

RELAZIONE DI CALCOLO FONDAZIONI PILE P1, P2, P21, P22, P23 E P24

COMMESSA IF28	LOTTO 01	CODIFICA E ZZ CL	DOCUMENTO VI0403 002	REV. B	FOGLIO 154 di 161
------------------	-------------	---------------------	-------------------------	-----------	-------------------------

MAXIMUM Pile N.	7050.7 3	-281.58 5	352.91 3	0.6567 1	-624.47 5	-730.13 5
--------------------	-------------	--------------	-------------	-------------	--------------	--------------

* EFFECTS FOR LATERALLY LOADED PILE *

PILE	DISPL. y-DIR M	DISPL. z-DIR M	MOMENT z-DIR KN- M	MOMENT y-DIR KN- M	SHEAR y-DIR KN	SHEAR z-DIR KN	SOIL REACT y-DIR KN/ M	SOIL REACT z-DIR KN/ M	TOTAL STRESS KN/ M**2
*****	*****	*****	*****	*****	*****	*****	*****	*****	*****
Min. Pile N.	-1.7163E-03 1	-4.5435E-05 5	-550.78 3	-834.56 3	-403.18 3	-137.11 3	-172.23 3	-42.847 3	856.23 7
Max. Pile N.	5.0231E-05 5	1.5727E-03 1	981.80 3	495.05 3	152.98 3	353.03 3	48.262 3	152.63 3	7878.8 3

LOAD CASE : 6

* TABLE L * COMPUTATION ON PILE CAP

* EQUIVALENT CONCENTRATED LOAD AT ORIGIN *

LOAD X, KN	LOAD Y, KN	LOAD Z, KN	MOM X, KN- M	MOM Y, KN- M	MOM Z, KN- M
13590.0	3258.20	-2693.90	-109.000	-30718.0	-32877.9

* DISPLACEMENT OF GROUPED PILE FOUNDATION AT ORIGIN *

DISP X, M	DISP Y, M	DISP Z, M	ROT X,RAD	ROT Y,RAD	ROT Z,RAD
7.06870E-04	1.81423E-03	-1.54026E-03	-9.29388E-07	-1.45194E-04	-1.59920E-04

* PILE TOP DISPLACEMENTS, GLOBAL *

	DISP. X, M	DISP. Y, M	DISP. Z, M	ROT. X,RAD	ROT. Y,RAD	ROT. Z,RAD
MINIMUM	-6.6615E-04	1.8100E-03	-1.5444E-03	-9.2939E-07	-1.4519E-04	-1.5992E-04
Pile N.	3	7	1	1	1	1
MAXIMUM	2.0799E-03	1.8184E-03	-1.5361E-03	-9.2939E-07	-1.4519E-04	-1.5992E-04
Pile N.	7	1	3	1	1	1

* PILE TOP REACTIONS, GLOBAL *

	FOR. X, KN	FOR. Y, KN	FOR. Z, KN	MOM X, KN- M	MOM Y, KN- M	MOM Z, KN- M
MINIMUM	-1458.5	301.83	-356.56	-0.3287	635.18	790.61
Pile N.	3	5	7	1	5	5
MAXIMUM	4352.5	427.67	-248.97	-0.3287	857.24	1048.3
Pile N.	7	7	5	1	7	7

* PILE TOP DISPLACEMENTS, LOCAL *

	DISP. x, M	DISP. y, M	DISP. z, M	ROT. x,RAD	ROT. y,RAD	ROT. z,RAD
MINIMUM	-6.6615E-04	1.8100E-03	-1.5444E-03	-9.2939E-07	-1.4519E-04	-1.5992E-04
Pile N.	3	7	1	1	1	1
MAXIMUM	2.0799E-03	1.8184E-03	-1.5361E-03	-9.2939E-07	-1.4519E-04	-1.5992E-04
Pile N.	7	1	3	1	1	1

* PILE TOP REACTIONS, LOCAL *

	AXIAL, KN	LAT. y, KN	LAT. z, KN	MOM x, KN- M	MOM y, KN- M	MOM z, KN- M
MINIMUM	-1458.5	301.83	-356.56	-0.3287	635.18	790.61
Pile N.	3	5	7	1	5	5
MAXIMUM	4352.5	427.67	-248.97	-0.3287	857.24	1048.3
Pile N.	7	7	5	1	7	7

* EFFECTS FOR LATERALLY LOADED PILE *

PILE	DISPL. y-DIR M	DISPL. z-DIR M	MOMENT z-DIR KN- M	MOMENT y-DIR KN- M	SHEAR y-DIR KN	SHEAR z-DIR KN	SOIL REACT y-DIR KN/ M	SOIL REACT z-DIR KN/ M	TOTAL STRESS KN/ M**2
*****	*****	*****	*****	*****	*****	*****	*****	*****	*****
Min. Pile N.	-5.3435E-05 5	-1.5444E-03 1	-1048.3 7	-490.95 7	-160.43 7	-356.63 7	-50.849 7	-151.40 7	15.871 6
Max. Pile N.	1.8184E-03 1	4.4910E-05 5	578.66 7	857.24 7	427.76 7	135.86 7	180.16 7	42.786 7	6550.1 7

LOAD CASE : 7

* TABLE L * COMPUTATION ON PILE CAP

* EQUIVALENT CONCENTRATED LOAD AT ORIGIN *

LOAD X, KN	LOAD Y, KN	LOAD Z, KN	MOM X, KN- M	MOM Y, KN- M	MOM Z, KN- M
21530.0	-3641.47	10471.2	-362.000	1.22170E+05	35854.8

* DISPLACEMENT OF GROUPED PILE FOUNDATION AT ORIGIN *

DISP X, M	DISP Y, M	DISP Z, M	ROT X,RAD	ROT Y,RAD	ROT Z,RAD
1.24187E-03	-2.69387E-03	7.84813E-03	-2.65587E-05	6.27383E-04	2.05055E-04

* PILE TOP DISPLACEMENTS, GLOBAL *

	DISP. X, M	DISP. Y, M	DISP. Z, M	ROT. X,RAD	ROT. Y,RAD	ROT. Z,RAD
MINIMUM	-2.5041E-03	-2.8134E-03	7.7286E-03	-2.6559E-05	6.2738E-04	2.0505E-04
Pile N.	7	7	1	1	1	1
MAXIMUM	4.9878E-03	-2.5743E-03	7.9676E-03	-2.6559E-05	6.2738E-04	2.0505E-04
Pile N.	3	1	3	1	1	1

APPALTATORE: Consorzio Soci   	ITINERARIO NAPOLI – BARI RADDOPPIO TRATTA APICE – ORSARA I LOTTO FUNZIONALE APICE – HIRPINIA
PROGETTAZIONE: Mandataria Mandanti   	
PROGETTO ESECUTIVO RELAZIONE DI CALCOLO FONDAZIONI PILE P1, P2, P21, P22, P23 E P24	

* PILE TOP REACTIONS, GLOBAL *

	FOR. X, KN	FOR. Y, KN	FOR. Z, KN	MOM X, KN- M	MOM Y, KN- M	MOM Z, KN- M
MINIMUM	-5173.5	-457.30	976.58	-9.3929	-3780.4	-1212.5
Pile N.	7	3	5	1	3	3
MAXIMUM	9175.6	-341.63	1421.0	-9.3929	-2756.9	-981.36
Pile N.	3	5	3	1	5	5

* PILE TOP DISPLACEMENTS, LOCAL *

	DISP. x, M	DISP. y, M	DISP. z, M	ROT. x,RAD	ROT. y,RAD	ROT. z,RAD
MINIMUM	-2.5041E-03	-2.8134E-03	7.7286E-03	-2.6559E-05	6.2738E-04	2.0505E-04
Pile N.	7	7	1	1	1	1
MAXIMUM	4.9878E-03	-2.5743E-03	7.9676E-03	-2.6559E-05	6.2738E-04	2.0505E-04
Pile N.	3	1	3	1	1	1

* PILE TOP REACTIONS, LOCAL *

	AXIAL, KN	LAT. y, KN	LAT. z, KN	MOM x, KN- M	MOM y, KN- M	MOM z, KN- M
MINIMUM	-5173.5	-457.30	976.58	-9.3929	-3780.4	-1212.5
Pile N.	7	3	5	1	3	3
MAXIMUM	9175.6	-341.63	1421.0	-9.3929	-2756.9	-981.36
Pile N.	3	5	3	1	5	5

* EFFECTS FOR Laterally LOADED PILE *

PILE	DISPL. y-DIR M	DISPL. z-DIR M	MOMENT z-DIR KN- M	MOMENT y-DIR KN- M	SHEAR y-DIR KN	SHEAR z-DIR KN	SOIL REACT y-DIR KN/ M	SOIL REACT z-DIR KN/ M	TOTAL STRESS KN/ M**2
Min.	-2.8134E-03	-1.9103E-04	-611.53	-3780.4	-457.51	-435.38	-143.49	-103.21	401.34
Pile N.	7	3	3	3	3	3	3	3	4
Max.	6.7085E-05	7.9676E-03	1212.5	1894.0	140.54	1421.6	33.302	445.24	1.7174E+04
Pile N.	9	3	3	3	3	3	3	3	3

LOAD CASE : 8

* TABLE L * COMPUTATION ON PILE CAP

* EQUIVALENT CONCENTRATED LOAD AT ORIGIN *

LOAD X, KN	LOAD Y, KN	LOAD Z, KN	MOM X, KN- M	MOM Y, KN- M	MOM Z, KN- M
30430.0	4052.27	-10547.2	362.000	-1.20285E+05	-40696.8

* DISPLACEMENT OF GROUPED PILE FOUNDATION AT ORIGIN *

DISP X, M	DISP Y, M	DISP Z, M	ROT X,RAD	ROT Y,RAD	ROT Z,RAD
1.78274E-03	3.03710E-03	-8.00705E-03	-1.15942E-05	-6.43218E-04	-2.34452E-04

* PILE TOP DISPLACEMENTS, GLOBAL *

	DISP. X, M	DISP. Y, M	DISP. Z, M	ROT. X,RAD	ROT. Y,RAD	ROT. Z,RAD
MINIMUM	-2.1668E-03	2.9849E-03	-8.0592E-03	-1.1594E-05	-6.4322E-04	-2.3445E-04
Pile N.	3	7	1	1	1	1
MAXIMUM	5.7323E-03	3.0893E-03	-7.9549E-03	-1.1594E-05	-6.4322E-04	-2.3445E-04
Pile N.	7	1	3	1	1	1

* PILE TOP REACTIONS, GLOBAL *

	FOR. X, KN	FOR. Y, KN	FOR. Z, KN	MOM X, KN- M	MOM Y, KN- M	MOM Z, KN- M
MINIMUM	-4491.7	378.67	-1418.0	-4.1005	2778.9	1086.4
Pile N.	3	5	7	1	5	5
MAXIMUM	1.0151E+04	528.08	-982.77	-4.1005	3768.4	1410.0
Pile N.	7	7	5	1	7	7

* PILE TOP DISPLACEMENTS, LOCAL *

	DISP. x, M	DISP. y, M	DISP. z, M	ROT. x,RAD	ROT. y,RAD	ROT. z,RAD
MINIMUM	-2.1668E-03	2.9849E-03	-8.0592E-03	-1.1594E-05	-6.4322E-04	-2.3445E-04
Pile N.	3	7	1	1	1	1
MAXIMUM	5.7323E-03	3.0893E-03	-7.9549E-03	-1.1594E-05	-6.4322E-04	-2.3445E-04
Pile N.	7	1	3	1	1	1

* PILE TOP REACTIONS, LOCAL *

	AXIAL, KN	LAT. y, KN	LAT. z, KN	MOM x, KN- M	MOM y, KN- M	MOM z, KN- M
MINIMUM	-4491.7	378.67	-1418.0	-4.1005	2778.9	1086.4
Pile N.	3	5	7	1	5	5
MAXIMUM	1.0151E+04	528.08	-982.77	-4.1005	3768.4	1410.0
Pile N.	7	7	5	1	7	7

* EFFECTS FOR Laterally LOADED PILE *

PILE	DISPL. y-DIR M	DISPL. z-DIR M	MOMENT z-DIR KN- M	MOMENT y-DIR KN- M	SHEAR y-DIR KN	SHEAR z-DIR KN	SOIL REACT y-DIR KN/ M	SOIL REACT z-DIR KN/ M	TOTAL STRESS KN/ M**2
Min.	-7.3373E-05	-8.0592E-03	-1410.0	-1906.0	-162.16	-1418.7	-38.120	-444.39	70.477
Pile N.	1	1	7	7	7	7	7	7	1

APPALTATORE:

Consorzio

Soci



ITINERARIO NAPOLI – BARI

PROGETTAZIONE:

Mandataria

Mandanti



RADDOPPIO TRATTA APICE – ORSARA
I LOTTO FUNZIONALE APICE – HIRPINIA

PROGETTO ESECUTIVO

RELAZIONE DI CALCOLO FONDAZIONI PILE P1, P2, P21, P22, P23
E P24

COMMESSA IF28	LOTTO 01	CODIFICA E ZZ CL	DOCUMENTO VI0403 002	REV. B	FOGLIO 156 di 161
------------------	-------------	---------------------	-------------------------	-----------	-------------------------

Max. Pile N.	3.0893E-03 1	1.9277E-04 7	706.63 7	3768.4 7	528.36 7	436.90 7	165.17 7	102.73 7	1.7888E+04 7
--------------	-----------------	-----------------	-------------	-------------	-------------	-------------	-------------	-------------	-----------------

LOAD CASE : 9

* TABLE L * COMPUTATION ON PILE CAP

* EQUIVALENT CONCENTRATED LOAD AT ORIGIN *

LOAD X, KN	LOAD Y, KN	LOAD Z, KN	MOM X, KN- M	MOM Y, KN- M	MOM Z, KN- M
23727.0	10828.4	-2743.40	-158.000	-30134.5	-1.08980E+05

* DISPLACEMENT OF GROUPED PILE FOUNDATION AT ORIGIN *

DISP X, M	DISP Y, M	DISP Z, M	ROT X,RAD	ROT Y,RAD	ROT Z,RAD
1.34385E-03	7.87064E-03	-2.07376E-03	1.33807E-05	-1.68150E-04	-5.76500E-04

* PILE TOP DISPLACEMENTS, GLOBAL *

DISP. X, M	DISP. Y, M	DISP. Z, M	ROT. X,RAD	ROT. Y,RAD	ROT. Z,RAD
MINIMUM	-2.0071E-03	7.8104E-03	-2.1340E-03	1.3381E-05	-1.6815E-04
Pile N.	3	1	3	1	1
MAXIMUM	4.6948E-03	7.9309E-03	-2.0135E-03	1.3381E-05	-1.6815E-04
Pile N.	7	7	1	1	1

* PILE TOP REACTIONS, GLOBAL *

FOR. X, KN	FOR. Y, KN	FOR. Z, KN	MOM X, KN- M	MOM Y, KN- M	MOM Z, KN- M
MINIMUM	-4168.9	1013.0	-352.92	4.7323	720.32
Pile N.	3	5	7	1	5
MAXIMUM	8765.7	1456.5	-256.78	4.7323	920.51
Pile N.	7	7	5	1	7

* PILE TOP DISPLACEMENTS, LOCAL *

DISP. X, M	DISP. Y, M	DISP. Z, M	ROT. X,RAD	ROT. Y,RAD	ROT. Z,RAD
MINIMUM	-2.0071E-03	7.8104E-03	-2.1340E-03	1.3381E-05	-1.6815E-04
Pile N.	3	1	3	1	1
MAXIMUM	4.6948E-03	7.9309E-03	-2.0135E-03	1.3381E-05	-1.6815E-04
Pile N.	7	7	1	1	1

* PILE TOP REACTIONS, LOCAL *

AXIAL, KN	LAT. y, KN	LAT. z, KN	MOM x, KN- M	MOM y, KN- M	MOM z, KN- M
MINIMUM	-4168.9	1013.0	-352.92	4.7323	720.32
Pile N.	3	5	7	1	5
MAXIMUM	8765.7	1456.5	-256.78	4.7323	920.51
Pile N.	7	7	5	1	7

* EFFECTS FOR Laterally LOADED PILE *

PILE	DISPL. y-DIR	DISPL. z-DIR	MOMENT z-DIR	MOMENT y-DIR	SHEAR z-DIR	SHEAR y-DIR	SOIL REACT y-DIR	SOIL REACT z-DIR	TOTAL STRESS
*****	*****	*****	*****	*****	*****	*****	*****	*****	*****
Min.	-1.9106E-04	-2.1340E-03	-3951.3	-476.92	-436.88	-353.07	-103.97	-111.45	613.60
Pile N.	7	3	7	7	7	7	7	7	9
Max.	7.9309E-03	5.0141E-05	1894.4	920.51	1457.1	109.36	452.35	25.973	1.7205E+04
Pile N.	7	9	7	7	7	7	7	7	7

LOAD CASE : 10

* TABLE L * COMPUTATION ON PILE CAP

* EQUIVALENT CONCENTRATED LOAD AT ORIGIN *

LOAD X, KN	LOAD Y, KN	LOAD Z, KN	MOM X, KN- M	MOM Y, KN- M	MOM Z, KN- M
29884.0	-10137.6	2693.90	109.000	30734.5	1.00646E+05

* DISPLACEMENT OF GROUPED PILE FOUNDATION AT ORIGIN *

DISP X, M	DISP Y, M	DISP Z, M	ROT X,RAD	ROT Y,RAD	ROT Z,RAD
1.69145E-03	-7.21107E-03	2.00934E-03	1.77499E-05	1.69349E-04	5.40137E-04

* PILE TOP DISPLACEMENTS, GLOBAL *

DISP. X, M	DISP. Y, M	DISP. Z, M	ROT. X,RAD	ROT. Y,RAD	ROT. Z,RAD
MINIMUM	-1.5012E-03	-7.2909E-03	1.9295E-03	1.7750E-05	1.6935E-04
Pile N.	7	1	3	1	1
MAXIMUM	4.8841E-03	-7.1312E-03	2.0892E-03	1.7750E-05	1.6935E-04
Pile N.	3	7	1	1	1

* PILE TOP REACTIONS, GLOBAL *

FOR. X, KN	FOR. Y, KN	FOR. Z, KN	MOM X, KN- M	MOM Y, KN- M	MOM Z, KN- M
MINIMUM	-3146.5	-1368.4	252.28	6.2775	-870.32
Pile N.	7	3	5	1	3
MAXIMUM	9030.5	-948.27	341.35	6.2775	-693.52
Pile N.	3	5	3	1	5

* PILE TOP DISPLACEMENTS, LOCAL *

DISP. x, M	DISP. y, M	DISP. z, M	ROT. x,RAD	ROT. y,RAD	ROT. z,RAD
------------	------------	------------	------------	------------	------------

APPALTATORE:

Consorzio

Soci



ITINERARIO NAPOLI – BARI

PROGETTAZIONE:

Mandataria

Mandanti



RADDOPPIO TRATTA APICE – ORSARA
I LOTTO FUNZIONALE APICE – HIRPINIA

PROGETTO ESECUTIVO

RELAZIONE DI CALCOLO FONDAZIONI PILE P1, P2, P21, P22, P23
E P24

COMMESSA
IF28

LOTTO
01

CODIFICA
E ZZ CL

DOCUMENTO
VI0403 002

REV.
B

FOGLIO
157 di
161

	*****	*****	*****	*****	*****	*****
MINIMUM	-1.5012E-03	-7.2909E-03	1.9295E-03	1.7750E-05	1.6935E-04	5.4014E-04
Pile N.	7	1	3	1	1	1
MAXIMUM	4.8841E-03	-7.1312E-03	2.0892E-03	1.7750E-05	1.6935E-04	5.4014E-04
Pile N.	3	7	1	1	1	1

* PILE TOP REACTIONS, LOCAL *

	AXIAL, KN	LAT. y, KN	LAT. z, KN	MOM x, KN- M	MOM y, KN- M	MOM z, KN- M
MINIMUM	-3146.5	-1368.4	252.28	6.2775	-870.32	-3670.6
Pile N.	7	3	5	1	3	3
MAXIMUM	9030.5	-948.27	341.35	6.2775	-693.52	-2721.1
Pile N.	3	5	3	1	5	5

* EFFECTS FOR LATERALLY LOADED PILE *

PILE	DISPL. y-DIR	DISPL. z-DIR	MOMENT z-DIR	MOMENT y-DIR	SHEAR y-DIR	SHEAR z-DIR	SOIL REACT y-DIR	SOIL REACT z-DIR	TOTAL STRESS
	M	M	KN- M	KN- M	KN	KN	KN/ M	KN/ M	KN/ M**2
Min.	-7.2909E-03	-5.0240E-05	-1770.9	-870.32	-1369.0	-107.84	-429.84	-26.112	28.811
Pile N.	1	7	3	3	3	3	3	3	1
Max.	1.7828E-04	2.0892E-03	3670.6	464.29	414.08	341.50	100.91	109.50	1.6495E+04
Pile N.	2	1	3	3	3	3	3	3	3

LOAD CASE : 11

* TABLE L * COMPUTATION ON PILE CAP

* EQUIVALENT CONCENTRATED LOAD AT ORIGIN *

LOAD X, KN	LOAD Y, KN	LOAD Z, KN	MOM X, KN- M	MOM Y, KN- M	MOM Z, KN- M
40569.0	3786.00	-1067.00	-361.000	-17067.5	-44997.0

* DISPLACEMENT OF GROUPED PILE FOUNDATION AT ORIGIN *

DISP X, M	DISP Y, M	DISP Z, M	ROT X,RAD	ROT Y,RAD	ROT Z,RAD
2.16522E-03	2.23587E-03	-6.89376E-04	-8.25881E-07	-8.17283E-05	-2.22622E-04

* PILE TOP DISPLACEMENTS, GLOBAL *

	DISP. X, M	DISP. Y, M	DISP. Z, M	ROT. X,RAD	ROT. Y,RAD	ROT. Z,RAD
MINIMUM	7.9565E-04	2.2322E-03	-6.9309E-04	-8.2588E-07	-8.1728E-05	-2.2262E-04
Pile N.	3	7	1	1	1	1
MAXIMUM	3.5348E-03	2.2396E-03	-6.8566E-04	-8.2588E-07	-8.1728E-05	-2.2262E-04
Pile N.	7	1	3	1	1	1

* PILE TOP REACTIONS, GLOBAL *

	FOR. X, KN	FOR. Y, KN	FOR. Z, KN	MOM X, KN- M	MOM Y, KN- M	MOM Z, KN- M
MINIMUM	1745.1	354.64	-144.86	-0.2921	221.98	885.57
Pile N.	3	5	7	1	6	5
MAXIMUM	7143.3	505.51	-99.162	-0.2921	316.43	1192.5
Pile N.	7	7	5	1	7	7

* PILE TOP DISPLACEMENTS, LOCAL *

	DISP. x, M	DISP. y, M	DISP. z, M	ROT. x,RAD	ROT. y,RAD	ROT. z,RAD
MINIMUM	7.9565E-04	2.2322E-03	-6.9309E-04	-8.2588E-07	-8.1728E-05	-2.2262E-04
Pile N.	3	7	1	1	1	1
MAXIMUM	3.5348E-03	2.2396E-03	-6.8566E-04	-8.2588E-07	-8.1728E-05	-2.2262E-04
Pile N.	7	1	3	1	1	1

* PILE TOP REACTIONS, LOCAL *

	AXIAL, KN	LAT. y, KN	LAT. z, KN	MOM x, KN- M	MOM y, KN- M	MOM z, KN- M
MINIMUM	1745.1	354.64	-144.86	-0.2921	221.98	885.57
Pile N.	3	5	7	1	6	5
MAXIMUM	7143.3	505.51	-99.162	-0.2921	316.43	1192.5
Pile N.	7	7	5	1	7	7

* EFFECTS FOR LATERALLY LOADED PILE *

PILE	DISPL. y-DIR	DISPL. z-DIR	MOMENT z-DIR	MOMENT y-DIR	SHEAR y-DIR	SHEAR z-DIR	SOIL REACT y-DIR	SOIL REACT z-DIR	TOTAL STRESS
	M	M	KN- M	KN- M	KN	KN	KN/ M	KN/ M	KN/ M**2
Min.	-6.5130E-05	-6.9309E-04	-1192.5	-218.17	-196.98	-144.90	-61.596	-64.680	987.50
Pile N.	5	1	7	7	7	7	1	7	3
Max.	2.2396E-03	1.9431E-05	711.34	316.43	505.67	59.942	219.28	18.278	7765.9
Pile N.	1	5	7	7	7	7	7	7	7

LOAD CASE : 12

* TABLE L * COMPUTATION ON PILE CAP

* EQUIVALENT CONCENTRATED LOAD AT ORIGIN *

LOAD X, KN	LOAD Y, KN	LOAD Z, KN	MOM X, KN- M	MOM Y, KN- M	MOM Z, KN- M
44090.0	1340.00	-1605.00	-5.00000	-25249.5	-13499.0

APPALTATORE:

Consorzio

Soci



ITINERARIO NAPOLI – BARI

PROGETTAZIONE:

Mandatario

Mandanti

RADDOPPIO TRATTA APICE – ORSARA
I LOTTO FUNZIONALE APICE – HIRPINIA

PROGETTO ESECUTIVO

RELAZIONE DI CALCOLO FONDAZIONI PILE P1, P2, P21, P22, P23
E P24COMMESSA
IF28LOTTO
01CODIFICA
E ZZ CLDOCUMENTO
VI0403 002REV.
BFOGLIO
158 di
161

* DISPLACEMENT OF GROUPED PILE FOUNDATION AT ORIGIN *

DISP X, M	DISP Y, M	DISP Z, M	ROT X,RAD	ROT Y,RAD	ROT Z,RAD
2.34897E-03	6.90863E-04	-9.34423E-04	-1.15834E-06	-1.16471E-04	-6.79675E-05

* PILE TOP DISPLACEMENTS, GLOBAL *

	DISP. X, M	DISP. Y, M	DISP. Z, M	ROT. X,RAD	ROT. Y,RAD	ROT. Z,RAD
MINIMUM	1.5190E-03	6.8565E-04	-9.3963E-04	-1.1583E-06	-1.1647E-04	-6.7968E-05
Pile N.	3	7	1	1	1	1
MAXIMUM	3.1789E-03	6.9608E-04	-9.2921E-04	-1.1583E-06	-1.1647E-04	-6.7968E-05
Pile N.	7	1	3	1	1	1

* PILE TOP REACTIONS, GLOBAL *

	FOR. X, KN	FOR. Y, KN	FOR. Z, KN	MOM X, KN- M	MOM Y, KN- M	MOM Z, KN- M
MINIMUM	3213.7	129.71	-209.49	-0.4097	340.73	326.25
Pile N.	3	5	7	1	5	5
MAXIMUM	6584.1	170.31	-153.96	-0.4097	446.88	401.49
Pile N.	7	7	5	1	7	7

* PILE TOP DISPLACEMENTS, LOCAL *

	DISP. x, M	DISP. y, M	DISP. z, M	ROT. x,RAD	ROT. y,RAD	ROT. z,RAD
MINIMUM	1.5190E-03	6.8565E-04	-9.3963E-04	-1.1583E-06	-1.1647E-04	-6.7968E-05
Pile N.	3	7	1	1	1	1
MAXIMUM	3.1789E-03	6.9608E-04	-9.2921E-04	-1.1583E-06	-1.1647E-04	-6.7968E-05
Pile N.	7	1	3	1	1	1

* PILE TOP REACTIONS, LOCAL *

	AXIAL, KN	LAT. y, KN	LAT. z, KN	MOM x, KN- M	MOM y, KN- M	MOM z, KN- M
MINIMUM	3213.7	129.71	-209.49	-0.4097	340.73	326.25
Pile N.	3	5	7	1	5	5
MAXIMUM	6584.1	170.31	-153.96	-0.4097	446.88	401.49
Pile N.	7	7	5	1	7	7

* EFFECTS FOR LATERALLY LOADED PILE *

PILE	DISPL. y-DIR M	DISPL. z-DIR M	MOMENT z-DIR KN- M	MOMENT y-DIR KN- M	SHEAR y-DIR KN	SHEAR z-DIR KN	SOIL REACT y-DIR KN/ M	SOIL REACT z-DIR KN/ M	TOTAL STRESS KN/ M**2
Min.	-1.8590E-05	-9.3964E-04	-401.49	-326.48	-69.834	-209.55	-22.546	-115.87	1818.6
Pile N.	5	1	7	7	7	7	7	7	3
Max.	6.9608E-04	2.4148E-05	243.82	446.88	170.36	93.009	90.616	29.790	5538.9
Pile N.	1	5	7	7	7	7	7	7	7

LOAD CASE : 13

* TABLE L * COMPUTATION ON PILE CAP

* EQUIVALENT CONCENTRATED LOAD AT ORIGIN *

LOAD X, KN	LOAD Y, KN	LOAD Z, KN	MOM X, KN- M	MOM Y, KN- M	MOM Z, KN- M
44090.0	2002.00	-1605.00	-5.00000	-25249.5	-21147.0

* DISPLACEMENT OF GROUPED PILE FOUNDATION AT ORIGIN *

DISP X, M	DISP Y, M	DISP Z, M	ROT X,RAD	ROT Y,RAD	ROT Z,RAD
2.35184E-03	1.06683E-03	-9.54470E-04	1.21492E-07	-1.17506E-04	-1.06379E-04

* PILE TOP DISPLACEMENTS, GLOBAL *

	DISP. X, M	DISP. Y, M	DISP. Z, M	ROT. X,RAD	ROT. Y,RAD	ROT. Z,RAD
MINIMUM	1.3444E-03	1.0663E-03	-9.5502E-04	1.2149E-07	-1.1751E-04	-1.0638E-04
Pile N.	3	1	3	1	1	1
MAXIMUM	3.3593E-03	1.0674E-03	-9.5392E-04	1.2149E-07	-1.1751E-04	-1.0638E-04
Pile N.	7	7	1	1	1	1

* PILE TOP REACTIONS, GLOBAL *

	FOR. X, KN	FOR. Y, KN	FOR. Z, KN	MOM X, KN- M	MOM Y, KN- M	MOM Z, KN- M
MINIMUM	2859.1	193.13	-207.81	0.042968	342.20	483.60
Pile N.	3	5	7	1	5	5
MAXIMUM	6897.9	257.76	-153.65	0.042968	443.98	606.80
Pile N.	7	7	5	1	7	7

* PILE TOP DISPLACEMENTS, LOCAL *

	DISP. x, M	DISP. y, M	DISP. z, M	ROT. x,RAD	ROT. y,RAD	ROT. z,RAD
MINIMUM	1.3444E-03	1.0663E-03	-9.5502E-04	1.2149E-07	-1.1751E-04	-1.0638E-04
Pile N.	3	1	3	1	1	1
MAXIMUM	3.3593E-03	1.0674E-03	-9.5392E-04	1.2149E-07	-1.1751E-04	-1.0638E-04
Pile N.	7	7	1	1	1	1

* PILE TOP REACTIONS, LOCAL *

	AXIAL, KN	LAT. y, KN	LAT. z, KN	MOM x, KN- M	MOM y, KN- M	MOM z, KN- M
MINIMUM	2859.1	193.13	-207.81	0.042968	342.20	483.60
Pile N.	3	5	7	1	5	5

APPALTATORE:

Consorzio

Soci



ITINERARIO NAPOLI – BARI

PROGETTAZIONE:

Mandataria

Mandanti



RADDOPPIO TRATTA APICE – ORSARA
I LOTTO FUNZIONALE APICE – HIRPINIA

PROGETTO ESECUTIVO

RELAZIONE DI CALCOLO FONDAZIONI PILE P1, P2, P21, P22, P23
E P24

COMMESSA IF28	LOTTO 01	CODIFICA E ZZ CL	DOCUMENTO VI0403 002	REV. B	FOGLIO 159 di 161
------------------	-------------	---------------------	-------------------------	-----------	-------------------------

MAXIMUM Pile N.	6897.9 7	257.76 7	-153.65 5	0.042968 1	443.98 7	606.80 7
--------------------	-------------	-------------	--------------	---------------	-------------	-------------

* EFFECTS FOR LATERALLY LOADED PILE *

PILE	DISPL. y-DIR M	DISPL. z-DIR M	MOMENT z-DIR KN- M	MOMENT y-DIR KN- M	SHEAR y-DIR KN	SHEAR z-DIR KN	SOIL REACT y-DIR KN/ M	SOIL REACT z-DIR KN/ M	TOTAL STRESS KN/ M**2
*****	*****	*****	*****	*****	*****	*****	*****	*****	*****
Min.	-2.8756E-05	-9.5502E-04	-606.80	-321.90	-104.94	-207.86	-32.824	-107.89	1617.9
Pile N.	5	3	7	7	7	7	7	7	3
Max.	1.0674E-03	2.4764E-05	367.75	443.98	257.84	91.165	128.96	28.150	6172.6
Pile N.	7	5	7	7	7	7	7	7	7

LOAD CASE : 14

* TABLE L * COMPUTATION ON PILE CAP

* EQUIVALENT CONCENTRATED LOAD AT ORIGIN *

LOAD X, KN	LOAD Y, KN	LOAD Z, KN	MOM X, KN- M	MOM Y, KN- M	MOM Z, KN- M
28497.0	507.000	-1232.00	0.00000	-19151.0	-6046.50

* DISPLACEMENT OF GROUPED PILE FOUNDATION AT ORIGIN *

DISP X, M	DISP Y, M	DISP Z, M	ROT X,RAD	ROT Y,RAD	ROT Z,RAD
1.49566E-03	2.62167E-04	-6.88406E-04	-1.10811E-06	-8.83125E-05	-2.92646E-05

* PILE TOP DISPLACEMENTS, GLOBAL *

	DISP. X, M	DISP. Y, M	DISP. Z, M	ROT. X,RAD	ROT. Y,RAD	ROT. Z,RAD
*****	*****	*****	*****	*****	*****	*****
MINIMUM	9.6656E-04	2.5718E-04	-6.9339E-04	-1.1081E-06	-8.8312E-05	-2.9265E-05
Pile N.	3	7	1	1	1	1
MAXIMUM	2.0248E-03	2.6715E-04	-6.8342E-04	-1.1081E-06	-8.8312E-05	-2.9265E-05
Pile N.	7	1	3	1	1	1

* PILE TOP REACTIONS, GLOBAL *

	FOR. X, KN	FOR. Y, KN	FOR. Z, KN	MOM X, KN- M	MOM Y, KN- M	MOM Z, KN- M
*****	*****	*****	*****	*****	*****	*****
MINIMUM	2092.1	49.310	-161.07	-0.3919	259.05	116.97
Pile N.	3	5	7	1	5	5
MAXIMUM	4240.6	63.464	-118.99	-0.3919	339.34	141.68
Pile N.	7	7	5	1	7	7

* PILE TOP DISPLACEMENTS, LOCAL *

	DISP. x, M	DISP. y, M	DISP. z, M	ROT. x,RAD	ROT. y,RAD	ROT. z,RAD
*****	*****	*****	*****	*****	*****	*****
MINIMUM	9.6656E-04	2.5718E-04	-6.9339E-04	-1.1081E-06	-8.8312E-05	-2.9265E-05
Pile N.	3	7	1	1	1	1
MAXIMUM	2.0248E-03	2.6715E-04	-6.8342E-04	-1.1081E-06	-8.8312E-05	-2.9265E-05
Pile N.	7	1	3	1	1	1

* PILE TOP REACTIONS, LOCAL *

	AXIAL, KN	LAT. y, KN	LAT. z, KN	MOM x, KN- M	MOM y, KN- M	MOM z, KN- M
*****	*****	*****	*****	*****	*****	*****
MINIMUM	2092.1	49.310	-161.07	-0.3919	259.05	116.97
Pile N.	3	5	7	1	5	5
MAXIMUM	4240.6	63.464	-118.99	-0.3919	339.34	141.68
Pile N.	7	7	5	1	7	7

* EFFECTS FOR LATERALLY LOADED PILE *

PILE	DISPL. y-DIR M	DISPL. z-DIR M	MOMENT z-DIR KN- M	MOMENT y-DIR KN- M	SHEAR y-DIR KN	SHEAR z-DIR KN	SOIL REACT y-DIR KN/ M	SOIL REACT z-DIR KN/ M	TOTAL STRESS KN/ M**2
*****	*****	*****	*****	*****	*****	*****	*****	*****	*****
Min.	-7.2354E-06	-6.9339E-04	-141.68	-256.68	-27.640	-161.10	-8.6600	-102.56	1183.9
Pile N.	2	1	7	7	7	7	7	7	3
Max.	2.6715E-04	1.8381E-05	96.221	339.34	63.476	73.392	39.531	22.955	3509.5
Pile N.	1	5	7	7	7	7	7	7	7

LOAD CASE : 15

* TABLE L * COMPUTATION ON PILE CAP

* EQUIVALENT CONCENTRATED LOAD AT ORIGIN *

LOAD X, KN	LOAD Y, KN	LOAD Z, KN	MOM X, KN- M	MOM Y, KN- M	MOM Z, KN- M
39821.0	1404.00	-1290.00	0.00000	-27913.0	-15054.0

* DISPLACEMENT OF GROUPED PILE FOUNDATION AT ORIGIN *

DISP X, M	DISP Y, M	DISP Z, M	ROT X,RAD	ROT Y,RAD	ROT Z,RAD
2.11535E-03	7.28561E-04	-8.35224E-04	-7.32790E-07	-1.22988E-04	-7.46827E-05

* PILE TOP DISPLACEMENTS, GLOBAL *

	DISP. X, M	DISP. Y, M	DISP. Z, M	ROT. X,RAD	ROT. Y,RAD	ROT. Z,RAD
*****	*****	*****	*****	*****	*****	*****
MINIMUM	1.2258E-03	7.2526E-04	-8.3852E-04	-7.3279E-07	-1.2299E-04	-7.4683E-05
Pile N.	3	7	1	1	1	1
MAXIMUM	3.0049E-03	7.3186E-04	-8.3193E-04	-7.3279E-07	-1.2299E-04	-7.4683E-05
Pile N.	7	1	3	1	1	1

APPALTATORE: Consorzio HirpiniaAV Soci salini impreglio ASTALDI	ITINERARIO NAPOLI – BARI RADDOPPIO TRATTA APICE – ORSARA I LOTTO FUNZIONALE APICE – HIRPINIA				
PROGETTAZIONE: Mandataria ROKSOJL Mandanti NETENGINEERING Alpina					
PROGETTO ESECUTIVO RELAZIONE DI CALCOLO FONDAZIONI PILE P1, P2, P21, P22, P23 E P24					
COMMESSA IF28	LOTTO 01	CODIFICA E ZZ CL	DOCUMENTO VI0403 002	REV. B	FOGLIO 160 di 161

* PILE TOP REACTIONS, GLOBAL *

	FOR. X, KN	FOR. Y, KN	FOR. Z, KN	MOM X, KN- M	MOM Y, KN- M	MOM Z, KN- M
MINIMUM	2618.5	135.79	-169.25	-0.2592	231.00	335.65
Pile N.	3	5	7	1	5	7
MAXIMUM	6230.6	179.11	-122.69	-0.2592	318.57	416.56
Pile N.	7	7	5	1	7	7

* PILE TOP DISPLACEMENTS, LOCAL *

	DISP. x, M	DISP. y, M	DISP. z, M	ROT. x,RAD	ROT. y,RAD	ROT. z,RAD
MINIMUM	1.2258E-03	7.2526E-04	-8.3852E-04	-7.3279E-07	-1.2299E-04	-7.4683E-05
Pile N.	3	7	1	1	1	1
MAXIMUM	3.0049E-03	7.3186E-04	-8.3193E-04	-7.3279E-07	-1.2299E-04	-7.4683E-05
Pile N.	7	1	3	1	1	1

* PILE TOP REACTIONS, LOCAL *

	AXIAL, KN	LAT. y, KN	LAT. z, KN	MOM x, KN- M	MOM y, KN- M	MOM z, KN- M
MINIMUM	2618.5	135.79	-169.25	-0.2592	231.00	335.65
Pile N.	3	5	7	1	5	7
MAXIMUM	6230.6	179.11	-122.69	-0.2592	318.57	416.56
Pile N.	7	7	5	1	7	7

* EFFECTS FOR Laterally LOADED PILE *

PILE	DISPL. y-DIR M	DISPL. z-DIR M	MOMENT z-DIR KN- M	MOMENT y-DIR KN- M	SHEAR y-DIR KN	SHEAR z-DIR KN	SOIL REACT y-DIR KN/ M	SOIL REACT z-DIR KN/ M	TOTAL STRESS KN/ M**2
Min.	-1.9578E-05	-8.3852E-04	-416.56	-290.87	-74.467	-169.28	-23.951	-99.802	1481.8
Pile N.	5	1	7	7	7	7	7	7	3
Max.	7.3186E-04	2.1080E-05	260.12	318.57	179.16	82.505	97.961	25.911	5108.5
Pile N.	1	5	7	7	7	7	7	7	7

LOAD CASE : 16

* TABLE L * COMPUTATION ON PILE CAP

* EQUIVALENT CONCENTRATED LOAD AT ORIGIN *

LOAD X, KN	LOAD Y, KN	LOAD Z, KN	MOM X, KN- M	MOM Y, KN- M	MOM Z, KN- M
40569.0	3786.00	-1067.00	-361.000	-17067.5	-44997.0

* DISPLACEMENT OF GROUPED PILE FOUNDATION AT ORIGIN *

DISP X, M	DISP Y, M	DISP Z, M	ROT X,RAD	ROT Y,RAD	ROT Z,RAD
2.16522E-03	2.23587E-03	-6.89376E-04	-8.25881E-07	-8.17283E-05	-2.22622E-04

* PILE TOP DISPLACEMENTS, GLOBAL *

	DISP. X, M	DISP. Y, M	DISP. Z, M	ROT. X,RAD	ROT. Y,RAD	ROT. Z,RAD
MINIMUM	7.9565E-04	2.2322E-03	-6.9309E-04	-8.2588E-07	-8.1728E-05	-2.2262E-04
Pile N.	3	7	1	1	1	1
MAXIMUM	3.5348E-03	2.2396E-03	-6.8566E-04	-8.2588E-07	-8.1728E-05	-2.2262E-04
Pile N.	7	1	3	1	1	1

* PILE TOP REACTIONS, GLOBAL *

	FOR. X, KN	FOR. Y, KN	FOR. Z, KN	MOM X, KN- M	MOM Y, KN- M	MOM Z, KN- M
MINIMUM	1745.1	354.64	-144.86	-0.2921	221.98	885.57
Pile N.	3	5	7	1	6	5
MAXIMUM	7143.3	505.51	-99.162	-0.2921	316.43	1192.5
Pile N.	7	7	5	1	7	7

* PILE TOP DISPLACEMENTS, LOCAL *







	DISP. x, M	DISP. y, M	DISP. z, M	ROT. x,RAD	ROT. y,RAD	ROT. z,RAD
MINIMUM	7.9565E-04	2.2322E-03	-6.9309E-04	-8.2588E-07	-8.1728E-05	-2.2262E-04
Pile N.	3	7	1	1	1	1
MAXIMUM	3.5348E-03	2.2396E-03	-6.8566E-04	-8.2588E-07	-8.1728E-05	-2.2262E-04
Pile N.	7	1	3	1	1	1

* PILE TOP REACTIONS, LOCAL *

	AXIAL, KN	LAT. y, KN	LAT. z, KN	MOM x, KN- M	MOM y, KN- M	MOM z, KN- M
MINIMUM	1745.1	354.64	-144.86	-0.2921	221.98	885.57
Pile N.	3	5	7	1	6	5
MAXIMUM	7143.3	505.51	-99.162	-0.2921	316.43	1192.5
Pile N.	7	7	5	1	7	7

* EFFECTS FOR Laterally LOADED PILE *

PILE	DISPL. y-DIR M	DISPL. z-DIR M	MOMENT z-DIR KN- M	MOMENT y-DIR KN- M	SHEAR y-DIR KN	SHEAR z-DIR KN	SOIL REACT y-DIR KN/ M	SOIL REACT z-DIR KN/ M	TOTAL STRESS KN/ M**2
Min.	-6.5130E-05	-6.9309E-04	-1192.5	-218.17	-196.98	-144.90	-61.596	-64.680	987.50
Pile N.	5	1	7	7	7	7	1	7	3

APPALTATORE: Consorzio  Soci  	ITINERARIO NAPOLI – BARI RADDOPPIO TRATTA APICE – ORSARA I LOTTO FUNZIONALE APICE – HIRPINIA												
PROGETTAZIONE: Mandataria  Mandanti  							<table border="1"> <tr> <td data-bbox="721 291 869 376"> PROGETTO ESECUTIVO RELAZIONE DI CALCOLO FONDAZIONI PILE P1, P2, P21, P22, P23 E P24 </td> <td data-bbox="869 291 965 376"> COMMESSA IF28 </td> <td data-bbox="965 291 1061 376"> LOTTO 01 </td> <td data-bbox="1061 291 1157 376"> CODIFICA E ZZ CL </td> <td data-bbox="1157 291 1252 376"> DOCUMENTO VI0403 002 </td> <td data-bbox="1252 291 1348 376"> REV. B </td> <td data-bbox="1348 291 1481 376"> FOGLIO 161 di 161 </td> </tr> </table>						PROGETTO ESECUTIVO RELAZIONE DI CALCOLO FONDAZIONI PILE P1, P2, P21, P22, P23 E P24
PROGETTO ESECUTIVO RELAZIONE DI CALCOLO FONDAZIONI PILE P1, P2, P21, P22, P23 E P24	COMMESSA IF28	LOTTO 01	CODIFICA E ZZ CL	DOCUMENTO VI0403 002	REV. B	FOGLIO 161 di 161							

Max.	2.2396E-03	1.9431E-05	711.34	316.43	505.67	59.942	219.28	18.278	7765.9
Pile N.	1	5	7	7	7	7	7	7	7