



Università degli Studi di Napoli Federico II
 Dipartimento di Ingegneria Civile, Edile ed Ambientale
Laboratorio di Geotecnica

<u>Committente</u>	Consorzio HirpiniaAV
<u>Indagine</u>	I lotto funzionale Apice-Hirpinia
<u>Sondaggio</u>	SNME01
<u>Campione</u>	C3
<u>Profondità</u>	17.80 ÷ 18.40 m
<u>Data apertura</u>	12/11/19
<u>Operatore</u>	Alfredo Pozzo

Diametro (mm):	80
Lunghezza (mm):	600
Data di apertura:	12/11/2019

Stato del Campione	Indisturbato	x
	Parzialmente Rimaneggiato	
	Rimaneggiato	

Descrizione: Argilla varicolore, ammorbidita, con struttura microscagliosa. presenza di rare concrezioni calcaree						
Colore	Rosso, verde e grigio					
Plasticità	<input type="checkbox"/> Non Plastico	<input type="checkbox"/> Bassa	<input checked="" type="checkbox"/> Media alta	<input type="checkbox"/> Elevata		
Addensamento (Terreni granulari)	<input type="checkbox"/> Molto sciolto ($D_r=0.0\div 0.2$)	<input type="checkbox"/> Sciolto ($D_r=0.2\div 0.4$)	<input type="checkbox"/> Medio ($D_r=0.4\div 0.6$)	<input type="checkbox"/> Denso ($D_r=0.6\div 0.8$)	<input type="checkbox"/> Molto denso ($D_r=0.8\div 1.0$)	
Consistenza (Terreni coesivi)	<input type="checkbox"/> Molto molle ($I_c < 0.0$)	<input type="checkbox"/> Molle ($I_c=0.0\div 0.5$)	<input type="checkbox"/> Media ($I_c=0.5\div 1.0$)	<input checked="" type="checkbox"/> Consistente ($I_c > 1.0$)	<input type="checkbox"/> Molto consist. ($I_c \gg 1.0$)	
Grado di umidità	<input type="checkbox"/> Asciutto	<input type="checkbox"/> Poco Umido	<input checked="" type="checkbox"/> Umido	<input type="checkbox"/> Molto Umido		
Alterazione	<input checked="" type="checkbox"/> Assente	<input checked="" type="checkbox"/> Debole	<input type="checkbox"/> Media	<input type="checkbox"/> Elevata		
Struttura	Omogenea	<input type="checkbox"/> Stratificata	<input checked="" type="checkbox"/> Scagliosa	<input type="checkbox"/> Laminata	Caotica	
Fratturazione	<input checked="" type="checkbox"/> Assente	<input type="checkbox"/> Moderata	<input type="checkbox"/> Elevata			
Cementazione	<input checked="" type="checkbox"/> Assente	<input type="checkbox"/> Debole	<input type="checkbox"/> Media	<input type="checkbox"/> Elevata		

Proprietà fisiche			Proprietà meccaniche		
n,γ,w	X			Compressione uniassiale	
Analisi granulometrica	X			TX -UU	
Limiti	X			TX-CIU	x
CaCO ₃				TX-CID	
Sostanze organiche				TX-Ciclica	x
Peso specifico del solido				Taglio anulare	
Proctor				Taglio diretto	
CBR				RC TS	x
Altro _____				Altro _____	



Università degli Studi di Napoli Federico II

Dipartimento di Ingegneria Civile, Edile ed Ambientale

Laboratorio di Geotecnica

<u>Committente</u>	Consorzio HirpiniaAV
<u>Indagine</u>	I lotto funzionale Apice-Hirpinia
<u>Sondaggio</u>	SNME01
<u>Campione</u>	C3
<u>Profondità</u>	17.80 ÷ 18.40 m
<u>Data apertura</u>	12/11/19
<u>Operatore</u>	Alfredo Ponzo

FOTO CAMPIONE





Università degli Studi di Napoli
 Dipartimento di Ingegneria Civile, Edile e Ambientale
 Laboratorio di Geotecnica

Committente	Consorzio HirpiniaAV
Indagine	I lotto funzionale Apice-Hirpinia
Sondaggio	SNME01
Campione	C3
Profondità	17.80-18.40
Data	18/11/2019
Operatore	Alfredo Ponzo

LIMITE DI PLASTICITA'				
pesafiltro n°	Tara	Peso lordo umido (P _u)	Peso lordo secco (P _s)	Contenuto d'acqua (w)
[-]	[gr]	[gr]	[gr]	[-]
37	14.97	51.51	42.97	0.305
w_p				0.305

LIMITE DI LIQUIDITA' (Metodo di Casagrande ASTM)					
Pesafiltro n°	N° colpi (N)	Tara (P _c)	Peso lordo umido (P _u)	Peso lordo secco (P _s)	Contenuto d'acqua (w)
[-]	[-]	[g]	[g]	[g]	[g]
34	11	7.97	35.95	25.68	0.580
15	24	12.43	43.93	32.58	0.563
5	44	11.98	41.86	31.26	0.550
25 Limite di liquidità ASTM (w_L)					0.561

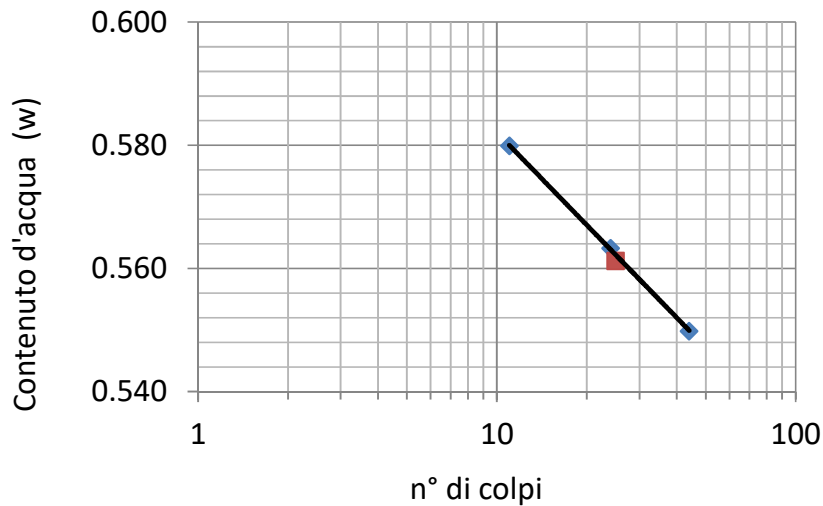

Indice di plasticità (I _p)	Frazione argillosa CF (d < 2 μm)	Indice di attività (I _A)
[%]	[%]	[-]
25.62	37.000	0.69

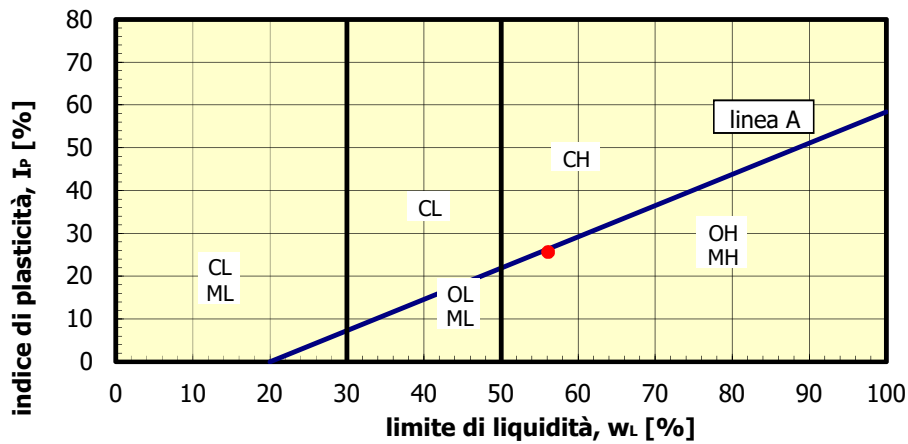

ML	Limi inorganici da bassa a media plasticità	M = limi
CL	Argille inorganiche da bassa a media plasticità	C = argille
OL	Limi e argille organiche di bassa plasticità	O = sostanze organiche
MH	Limi inorganici di alta plasticità	L = bassa plasticità
CH	Argille inorganiche di alta plasticità	H = alta plasticità
OH	Argille organiche da media ad alta plasticità	

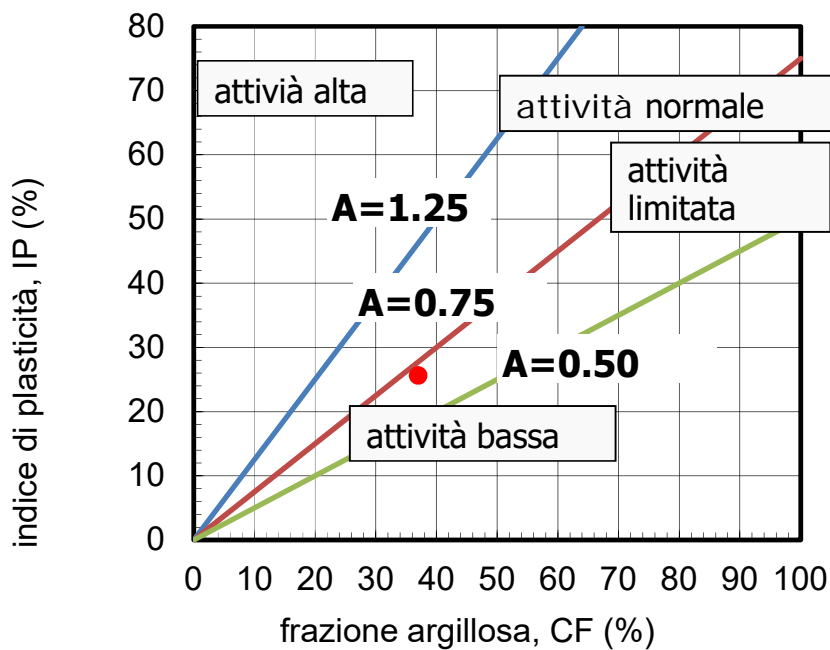

CONSISTENZA TERRENO A GRANA FINE		
w_L	I_p	I_c
[-]	[-]	[-]
56.118	25.62	2.18
COMPATTEZZA TERRENO A GRANA GROSSA		
e_{max}	e_{min}	D_r
[-]	[-]	[-]



Università degli studi di Napoli Federico II
Dipartimento di Ingegneria Civile, Edile e Ambientale
Laboratorio di Geotecnica

Committente	Consorzio HirpiniaAV
Indagine	Apice-Hirpinia
Sondaggio	SNME01
Campione	C3
Profondità	17.80-18.40
Data	18/11/2019
Operatore	Alfredo Ponzio

Peso specifico del solido	
Peso specifico dell'acqua (γ_w) (g/cm ³)	1.000
picnometro n°	18.000
Peso picnometro (P_p) (g)	59.76
Peso picnometro + acqua (P_{pw}) (g)	158.180
Volume picnometro (V_p) (cm ³)	98.42
Peso picnometro + terreno (P_{ps}) (g)	82.18
Peso terreno (P_s)	22.42
Peso picnometro + terreno + acqua (P_{psw}) (g)	172.480
Volume acqua aggiunta (V_w) (cm ³)	90.3
Volume terreno (V_s) (cm ³)	8.120
Peso specifico del terreno (γ_s) (kN/m ³)	27.075

Caratteristiche Fisiche Generali			
pesafiltro n°	37	17	20
Peso contenitore (P_c) (g)	14.96	20.71	15.53
Diametro (D) (mm)	56.00		
Altezza (H) (mm)	20.00		
Volume (V) (cm ³)	49.24		
Peso lordo umido (P_u) (g)	121.72	175.34	169.95
Peso lordo secco (P_s) (g)	105.56	150.05	144.06
Contenuto d'acqua (w)	0.18	0.20	0.20
Peso umido unità di volume (γ) (kN/m ³)	21.26		
Peso secco unità di volume (γ_d) (kN/m ³)	18.04		
Peso specifico del solido (γ_s) (kN/m ³)	27.08		
Porosità (n)	0.33		
Indice dei vuoti (e)	0.50		
Grado di Saturazione (S_r)	0.98		

Il responsabile della sperimentazione

Prof. Ing. Anna d'Onofrio



Università degli Studi di Napoli
 Dipartimento di Ingegneria Civile, Edile e Ambientale
 Laboratorio di Geotecnica

Committente	Consorzio HirpiniaAV
Indagine	I lotto funzionale Apice-Hirpinia
Sondaggio	SNME01
Campione	C3
Profondità	17.80 ÷ 18.40 m
Data	19/11/2019
Operatore	Alfredo Ponzo

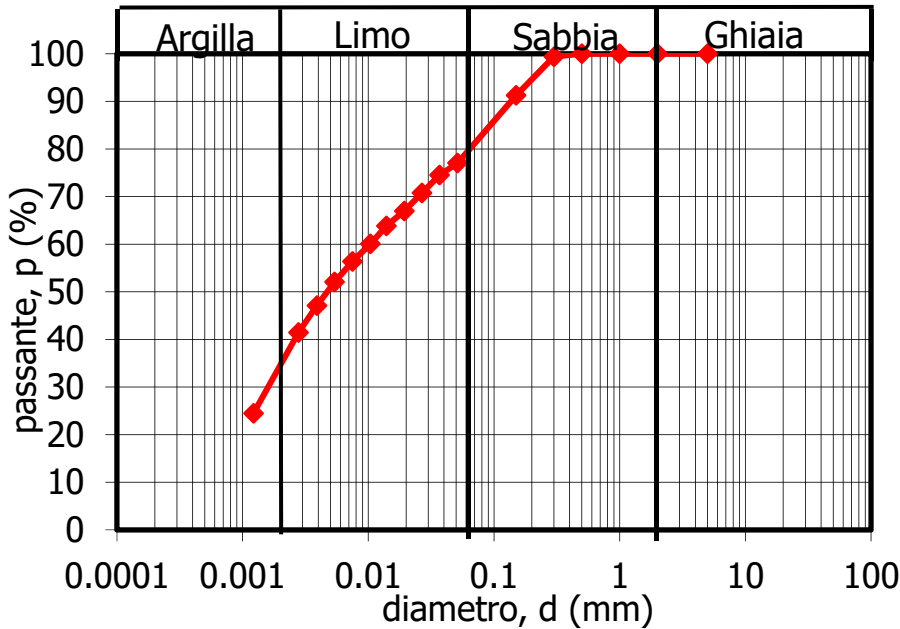

Curva granulometrica	
diametro (mm)	passante (%)
0.50	100.00
0.30	99.39
0.15	91.27
0.05	77.05
0.04	74.53
0.03	70.76
0.02	66.99
0.014	63.84
0.010	60.07
0.007	56.38
0.005	52.07
0.004	47.12
0.003	41.45
0.001	24.47

LIMO CON ARGILLA SABBIOSO

peso secco totale (g)	peso secco sediment. (g)
62.35	62.35

STACCIATURA			SEDIMENTAZIONE		
d (mm)	peso trattenuto (g)	peso passante (g)	tempo (min)	temperatura (°C)	lettura areometro (g/cm ³)
0.50	0.00	62.35		21	
0.30	0.38	61.97	0.5	21	1.032
0.15	5.44	56.91	1	21	1.031
			2	21	1.0295
			4	21	1.028
			8	21	1.02675
			15	21	1.02525
			30	21.25	1.02375
			60	21.5	1.022
			120	21.75	1.02
			240	23.5	1.0175
			1440	23.5	1.01075

G_s= 2.760

%<0.075mm	%ghiaia	%sabbia	%limo	%argilla	D _{max} (mm)	D ₆₀ (mm)	D ₁₀ (mm)
82	0	20	45	35	0.50	0.0100	

Normativa di riferimento : ASTM 422/90

responsabile della sperimentazione
 prof. Ing. Anna d'Onofrio



Università degli Studi di Napoli Federico II
Dipartimento di Ingegneria Idraulica,
Geotecnica ed Ambientale

Prova Compressione Triassiale n.		Celle n.
Prova tipo	TXC	
Committente	Consorzio Hirpinia AV	
Indagine	I lotto funzionale Apice-Hirpinia	
Sondaggio	SNME01	
Campione	3	
Profondità	17.80 + 18.40 m	

Condizioni inizio prova		Consolidazione		Condizioni fine prova	
		Pressione di cella σ_c kPa	580		
altezza h_0 mm	76.00	Contropressione u_0 kPa	200	altezza h mm	75.98
diametro d mm	38.00	Tensione effettiva σ'_c kPa	380	diametro d mm	38.00
peso umido iniziale g	184.72			Pesafiltro n° 37 g	14.93
Peso specifico γ_s kN/m ³	27.08			Pf + prov. umido g	200.35
Peso secco dell'udv γ_d kN/m³	17.79			Pf + prov.secco g	171.27
Contenuto d'acqua w	0.182			Peso specifico γ_s kN/m ³	27.08
Peso umido dell'udv γ kN/m³	27.03			Peso secco dell'udv γ_d kN/m³	17.80
Indice dei vuoti e	0.522			Contenuto d'acqua w	0.186
Grado di saturazione S_r	1.0			Peso umido dell'udv γ kN/m³	21.11
				Indice dei vuoti e	0.522
				Grado di saturazione S_r	1.0

Prova triassiale ciclica SNME01-C3			
ensione di confinamento (kPa)		380	
deviatore ciclico (kPa)		80	
frequenza (hz)		0.00071429	
tempo	cella di carico	u	LVDT
(min)	kN	(kPa)	δ (mm)
0.00	0.006	201.4	0
0.02	0.006	201.4	0
0.03	0.006	201.4	-0.0009
0.05	0.006	201.4	-0.0009
0.07	0.006	201.5	-0.0009
0.07	0.006	201.5	-0.0009
0.08	0.006	201.6	-0.0009
0.10	0.006	201.6	0
0.12	0.009	201.7	0
0.13	0.009	201.7	0.0009
0.15	0.009	201.7	0.0009
0.17	0.009	201.7	0.0009
0.18	0.009	201.7	0.0009
0.20	0.01	201.8	0.0009
0.22	0.01	201.8	0.0018
0.23	0.01	201.9	0.0018
0.25	0.01	201.9	0.0027
0.27	0.01	201.9	0.0027
0.28	0.012	201.9	0.0036
0.30	0.012	201.9	0.0036
0.33	0.013	202	0.0044
0.37	0.014	202.1	0.0053
0.40	0.015	202.2	0.0071
0.43	0.015	202.3	0.008
0.47	0.016	202.3	0.0089
0.50	0.017	202.5	0.0089
0.53	0.018	202.5	0.0107
0.57	0.02	202.6	0.0115
0.60	0.019	202.7	0.0142
0.63	0.019	202.7	0.0151
0.67	0.021	202.8	0.0178
0.70	0.022	202.9	0.0186
0.73	0.022	202.9	0.0204
0.77	0.024	203	0.0222
0.80	0.024	203.1	0.024
0.83	0.026	203.2	0.024
0.87	0.026	203.2	0.0257
0.90	0.026	203.2	0.0275
0.93	0.027	203.3	0.0293
0.97	0.028	203.4	0.0302
1.00	0.029	203.5	0.032
1.03	0.029	203.6	0.0328
1.07	0.031	203.7	0.0328
1.10	0.032	203.7	0.0346
1.13	0.032	203.8	0.0355
1.17	0.032	203.8	0.0355
1.20	0.034	203.9	0.0373
1.23	0.034	204	0.0382
1.27	0.035	204.1	0.0391
1.30	0.037	204.2	0.0391
1.33	0.037	204.2	0.0399
1.37	0.037	204.3	0.0408
1.40	0.037	204.3	0.0417
1.43	0.04	204.4	0.0426
1.48	0.04	204.5	0.0435
1.52	0.04	204.6	0.0444

Prova triassiale ciclica SNME01-C3			
ensione di confinamento (kPa)		380	
deviatore ciclico (kPa)		80	
frequenza (hz)		0.00071429	
tempo	cella di carico	u	LVDT
(min)	kN	(kPa)	δ (mm)
1.53	0.041	204.6	0.0453
1.57	0.043	204.7	0.0462
1.60	0.042	204.8	0.0462
1.63	0.043	204.9	0.0462
1.67	0.045	204.9	0.0479
1.70	0.045	205	0.0479
1.73	0.045	205	0.0488
1.77	0.046	205.1	0.0506
1.80	0.047	205.2	0.0515
1.83	0.048	205.3	0.0524
1.87	0.049	205.4	0.0524
1.90	0.05	205.4	0.0533
1.93	0.05	205.4	0.0541
1.97	0.05	205.5	0.0541
2.00	0.051	205.6	0.0559
2.03	0.052	205.7	0.0559
2.07	0.052	205.8	0.0568
2.10	0.054	205.9	0.0568
2.13	0.054	205.9	0.0577
2.17	0.054	205.9	0.0586
2.20	0.055	206	0.0595
2.23	0.056	206.1	0.0604
2.27	0.057	206.2	0.0604
2.30	0.058	206.3	0.0621
2.33	0.058	206.3	0.0621
2.37	0.059	206.3	0.0621
2.40	0.059	206.4	0.063
2.43	0.059	206.5	0.0639
2.47	0.061	206.6	0.0648
2.50	0.061	206.7	0.0657
2.53	0.062	206.7	0.0666
2.57	0.063	206.8	0.0666
2.60	0.064	206.8	0.0675
2.63	0.064	206.9	0.0683
2.67	0.064	207	0.0692
2.70	0.066	207.1	0.0701
2.73	0.066	207.2	0.071
2.77	0.067	207.2	0.0719
2.80	0.067	207.3	0.0719
2.83	0.068	207.3	0.0728
2.87	0.068	207.4	0.0737
2.92	0.069	207.5	0.0737
2.95	0.07	207.6	0.0746
2.97	0.07	207.6	0.0754
3.00	0.069	207.7	0.0754
3.03	0.072	207.8	0.0763
3.07	0.071	207.8	0.0772
3.10	0.072	207.9	0.0781
3.13	0.074	208	0.0781
3.17	0.074	208.1	0.079
3.20	0.074	208.1	0.0799
3.23	0.074	208.2	0.0799
3.27	0.075	208.3	0.0808
3.30	0.075	208.3	0.0817
3.33	0.076	208.4	0.0826
3.37	0.077	208.4	0.0826
3.40	0.077	208.5	0.0834
3.43	0.077	208.5	0.0834

Prova triassiale ciclica SNME01-C3			
ensione di confinamento (kPa)		380	
deviatore ciclico (kPa)		80	
frequenza (hz)		0.00071429	
tempo	cella di carico	u	LVDT
(min)	kN	(kPa)	δ (mm)
3.47	0.078	208.6	0.0843
3.50	0.078	208.7	0.0852
3.53	0.079	208.7	0.0861
3.57	0.08	208.8	0.0861
3.60	0.08	208.9	0.0861
3.63	0.08	209	0.087
3.67	0.08	209	0.0879
3.70	0.081	209.1	0.0888
3.73	0.082	209.1	0.0888
3.77	0.081	209.2	0.0897
3.80	0.083	209.3	0.0905
3.83	0.083	209.3	0.0905
3.87	0.084	209.3	0.0905
3.90	0.084	209.4	0.0914
3.93	0.083	209.5	0.0914
3.97	0.084	209.5	0.0923
4.00	0.085	209.6	0.0932
4.03	0.085	209.7	0.0932
4.07	0.086	209.8	0.0932
4.10	0.086	209.8	0.0941
4.13	0.086	209.8	0.095
4.17	0.087	209.9	0.095
4.20	0.088	210	0.0959
4.23	0.087	210.1	0.0959
4.27	0.087	210.1	0.0968
4.30	0.089	210.2	0.0968
4.33	0.089	210.2	0.0976
4.38	0.089	210.3	0.0976
4.42	0.089	210.4	0.0976
4.43	0.09	210.5	0.0985
4.47	0.09	210.5	0.0994
4.50	0.09	210.5	0.0994
4.53	0.09	210.6	0.0994
4.57	0.091	210.7	0.1003
4.60	0.09	210.7	0.1003
4.63	0.091	210.8	0.1003
4.67	0.092	210.9	0.1012
4.70	0.092	210.9	0.1012
4.73	0.091	210.9	0.1021
4.77	0.092	211	0.1021
4.80	0.093	211.1	0.103
4.83	0.093	211.1	0.103
4.87	0.092	211.2	0.103
4.90	0.093	211.2	0.103
4.93	0.093	211.2	0.1039
4.97	0.093	211.3	0.1039
5.00	0.094	211.4	0.1047
5.03	0.094	211.4	0.1047
5.07	0.094	211.5	0.1047
5.10	0.094	211.5	0.1047
5.13	0.094	211.6	0.1056
5.17	0.094	211.6	0.1056
5.20	0.094	211.6	0.1056
5.23	0.095	211.7	0.1065
5.27	0.095	211.8	0.1065
5.30	0.094	211.8	0.1065
5.33	0.095	211.9	0.1065
5.37	0.095	211.9	0.1074

Prova triassiale ciclica SNME01-C3			
pressione di confinamento (kPa)		380	
deviatore ciclico (kPa)		80	
frequenza (hz)		0.00071429	
tempo	cella di carico	u	LVDT
(min)	kN	(kPa)	δ (mm)
5.40	0.095	211.9	0.1074
5.43	0.095	212	0.1083
5.47	0.095	212	0.1083
5.50	0.096	212.1	0.1083
5.53	0.095	212.2	0.1083
5.57	0.096	212.2	0.1083
5.60	0.095	212.3	0.1092
5.63	0.095	212.3	0.1092
5.67	0.096	212.3	0.1092
5.70	0.097	212.4	0.1092
5.73	0.096	212.4	0.1092
5.77	0.096	212.5	0.1101
5.80	0.095	212.5	0.1101
5.85	0.095	212.5	0.1101
5.87	0.096	212.6	0.1101
5.90	0.096	212.7	0.1101
5.93	0.096	212.7	0.1101
5.97	0.096	212.7	0.111
6.00	0.097	212.8	0.111
6.03	0.096	212.8	0.111
6.07	0.096	212.9	0.111
6.10	0.095	212.9	0.111
6.13	0.095	212.9	0.111
6.17	0.096	213	0.111
6.20	0.096	213	0.111
6.23	0.095	213	0.111
6.27	0.095	213	0.111
6.30	0.095	213.1	0.111
6.33	0.095	213.1	0.1118
6.37	0.095	213.2	0.1118
6.40	0.095	213.2	0.1118
6.43	0.095	213.2	0.1118
6.47	0.095	213.2	0.1118
6.50	0.095	213.3	0.1118
6.53	0.095	213.3	0.1118
6.57	0.094	213.3	0.1118
6.60	0.094	213.4	0.1118
6.63	0.094	213.4	0.1118
6.67	0.094	213.4	0.1118
6.70	0.094	213.4	0.1118
6.73	0.094	213.5	0.1118
6.77	0.094	213.5	0.1118
6.80	0.093	213.5	0.111
6.83	0.093	213.6	0.111
6.87	0.093	213.6	0.111
6.90	0.093	213.6	0.111
6.93	0.093	213.6	0.111
6.97	0.092	213.6	0.111
7.00	0.092	213.7	0.111
7.03	0.091	213.7	0.111
7.07	0.091	213.7	0.111
7.10	0.091	213.7	0.111
7.13	0.091	213.7	0.111
7.17	0.091	213.8	0.111
7.20	0.09	213.8	0.111
7.23	0.091	213.8	0.111
7.28	0.09	213.8	0.111
7.32	0.089	213.9	0.111

Prova triassiale ciclica SNME01-C3			
ensione di confinamento (kPa)		380	
deviatore ciclico (kPa)		80	
frequenza (hz)		0.00071429	
tempo	cella di carico	u	LVDT
(min)	kN	(kPa)	δ (mm)
7.33	0.089	213.9	0.111
7.37	0.089	213.9	0.1101
7.40	0.088	213.9	0.1101
7.43	0.088	213.9	0.1101
7.47	0.088	213.9	0.1101
7.50	0.087	213.9	0.1101
7.53	0.087	214	0.1101
7.57	0.087	214	0.1092
7.60	0.086	214	0.1092
7.63	0.086	214	0.1092
7.67	0.085	214	0.1092
7.70	0.085	214	0.1092
7.73	0.085	214	0.1092
7.77	0.085	214	0.1092
7.80	0.084	214.1	0.1092
7.83	0.083	214.1	0.1083
7.87	0.084	214.1	0.1083
7.90	0.083	214.1	0.1083
7.93	0.083	214.1	0.1083
7.97	0.082	214.1	0.1074
8.00	0.082	214.1	0.1074
8.03	0.081	214.1	0.1074
8.07	0.08	214.1	0.1074
8.10	0.08	214.1	0.1074
8.13	0.08	214.1	0.1074
8.17	0.08	214.1	0.1074
8.20	0.079	214.1	0.1065
8.23	0.078	214.1	0.1065
8.27	0.078	214.1	0.1056
8.30	0.077	214.1	0.1056
8.33	0.076	214.1	0.1056
8.37	0.076	214.1	0.1056
8.40	0.076	214.1	0.1047
8.43	0.075	214.1	0.1047
8.47	0.075	214.1	0.1039
8.50	0.074	214.1	0.1039
8.53	0.073	214.1	0.1039
8.57	0.073	214.1	0.1039
8.60	0.072	214.1	0.103
8.63	0.072	214.1	0.103
8.67	0.072	214.1	0.103
8.70	0.071	214.1	0.1021
8.75	0.07	214.1	0.1021
8.78	0.07	214.1	0.1012
8.80	0.069	214.1	0.1012
8.83	0.068	214.1	0.1003
8.87	0.068	214.1	0.1003
8.90	0.068	214.1	0.1003
8.93	0.066	214.1	0.1003
8.97	0.066	214.1	0.0994
9.00	0.066	214.1	0.0985
9.03	0.066	214.1	0.0985
9.07	0.064	214	0.0976
9.10	0.064	214	0.0976
9.13	0.063	214	0.0976
9.17	0.062	214	0.0968
9.20	0.062	214	0.0968
9.23	0.062	214	0.0959

Prova triassiale ciclica SNME01-C3			
pressione di confinamento (kPa)		380	
deviatore ciclico (kPa)		80	
frequenza (hz)		0.00071429	
tempo	cella di carico	u	LVDT
(min)	kN	(kPa)	δ (mm)
9.27	0.061	214	0.0959
9.30	0.06	214	0.095
9.33	0.059	214	0.0941
9.37	0.058	213.9	0.0941
9.40	0.058	213.9	0.0932
9.43	0.058	213.9	0.0932
9.47	0.057	213.9	0.0923
9.50	0.056	213.9	0.0914
9.53	0.055	213.9	0.0905
9.57	0.055	213.9	0.0905
9.60	0.054	213.9	0.0905
9.63	0.052	213.8	0.0905
9.67	0.052	213.8	0.0897
9.70	0.052	213.8	0.0888
9.73	0.051	213.8	0.0879
9.77	0.051	213.8	0.087
9.80	0.05	213.7	0.0861
9.83	0.048	213.7	0.0861
9.87	0.048	213.7	0.0852
9.90	0.048	213.7	0.0843
9.93	0.047	213.7	0.0843
9.97	0.047	213.6	0.0834
10.00	0.046	213.6	0.0826
10.03	0.045	213.6	0.0817
10.07	0.043	213.5	0.0817
10.10	0.043	213.5	0.0799
10.13	0.043	213.5	0.0799
10.18	0.041	213.4	0.0781
10.22	0.041	213.4	0.0781
10.23	0.041	213.4	0.0772
10.27	0.041	213.4	0.0763
10.30	0.039	213.4	0.0754
10.33	0.038	213.3	0.0746
10.37	0.037	213.3	0.0728
10.40	0.036	213.3	0.0728
10.43	0.035	213.2	0.0728
10.47	0.035	213.2	0.0719
10.50	0.035	213.2	0.0701
10.53	0.034	213.2	0.0692
10.57	0.033	213.2	0.0683
10.60	0.032	213.1	0.0675
10.63	0.031	213.1	0.0666
10.67	0.03	213	0.0666
10.70	0.03	213	0.0648
10.73	0.029	213	0.0639
10.77	0.028	212.9	0.063
10.80	0.027	212.9	0.0621
10.83	0.026	212.9	0.0612
10.87	0.025	212.8	0.0595
10.90	0.024	212.8	0.0595
10.93	0.024	212.8	0.0586
10.97	0.024	212.8	0.0577
11.00	0.023	212.7	0.0568
11.03	0.022	212.6	0.0559
11.07	0.021	212.6	0.055
11.10	0.02	212.6	0.0541
11.13	0.019	212.5	0.0541
11.17	0.019	212.5	0.0524

Prova triassiale ciclica SNME01-C3			
pressione di confinamento (kPa)		380	
deviatore ciclico (kPa)		80	
frequenza (hz)		0.00071429	
tempo	cella di carico	u	LVDT
(min)	kN	(kPa)	δ (mm)
11.20	0.018	212.5	0.0515
11.23	0.017	212.4	0.0497
11.27	0.016	212.4	0.0488
11.30	0.015	212.3	0.047
11.33	0.014	212.3	0.0462
11.37	0.013	212.2	0.0462
11.40	0.013	212.2	0.0444
11.43	0.013	212.2	0.0435
11.47	0.012	212.1	0.0426
11.50	0.011	212.1	0.0408
11.53	0.01	212	0.0399
11.57	0.009	211.9	0.0382
11.60	0.007	211.9	0.0382
11.65	0.007	211.8	0.0355
11.68	0.006	211.8	0.0337
11.70	0.005	211.7	0.0337
11.73	0.005	211.7	0.0328
11.77	0.004	211.7	0.032
11.80	0.003	211.6	0.0302
11.83	0.002	211.6	0.0293
11.87	0.001	211.6	0.0275
11.90	0.001	211.5	0.0257
11.93	-0.001	211.4	0.0257
11.97	-0.001	211.4	0.0231
12.00	-0.001	211.3	0.0204
12.03	-0.002	211.2	0.0178
12.07	-0.003	211.2	0.0142
12.10	-0.005	211.1	0.0115
12.13	-0.005	211	0.008
12.17	-0.007	210.9	0.008
12.20	-0.007	210.9	0.0044
12.23	-0.006	210.9	0.0009
12.27	-0.007	210.8	-0.0044
12.30	-0.01	210.7	-0.0107
12.33	-0.009	210.7	-0.0178
12.37	-0.011	210.5	-0.0284
12.40	-0.012	210.4	-0.0284
12.43	-0.012	210.4	-0.0444
12.47	-0.012	210.3	-0.0719
12.50	-0.013	210.2	-0.0985
12.53	-0.015	210	-0.1172
12.57	-0.015	209.9	-0.1278
12.60	-0.016	209.8	-0.1367
12.63	-0.016	209.7	-0.1367
12.67	-0.016	209.7	-0.1544
12.70	-0.018	209.4	-0.174
12.73	-0.019	209.3	-0.182
12.77	-0.021	209.1	-0.19
12.80	-0.022	209.1	-0.1944
12.83	-0.021	209	-0.1979
12.87	-0.023	208.9	-0.1979
12.90	-0.023	208.9	-0.2024
12.93	-0.024	208.8	-0.2068
12.97	-0.024	208.7	-0.2113
13.00	-0.025	208.7	-0.2148
13.03	-0.026	208.6	-0.2175
13.08	-0.027	208.5	-0.221
13.12	-0.028	208.4	-0.2255

Prova triassiale ciclica SNME01-C3			
pressione di confinamento (kPa)		380	
deviatore ciclico (kPa)		80	
frequenza (hz)		0.00071429	
tempo	cella di carico	u	LVDT
(min)	kN	(kPa)	δ (mm)
13.13	-0.028	208.4	-0.2281
13.17	-0.029	208.3	-0.2317
13.20	-0.031	208.2	-0.2317
13.23	-0.031	208.2	-0.2352
13.27	-0.031	208.1	-0.2388
13.30	-0.032	208	-0.2414
13.33	-0.033	208	-0.245
13.37	-0.034	207.8	-0.2468
13.40	-0.034	207.8	-0.2494
13.43	-0.036	207.7	-0.2494
13.47	-0.035	207.7	-0.2512
13.50	-0.035	207.6	-0.2548
13.53	-0.037	207.5	-0.2574
13.57	-0.039	207.4	-0.2601
13.60	-0.039	207.4	-0.2627
13.63	-0.039	207.3	-0.2672
13.67	-0.04	207.2	-0.2672
13.70	-0.04	207.2	-0.2698
13.73	-0.041	207.1	-0.2734
13.77	-0.042	207	-0.2761
13.80	-0.042	206.9	-0.2778
13.83	-0.043	206.8	-0.2796
13.87	-0.044	206.8	-0.2823
13.90	-0.046	206.7	-0.2823
13.93	-0.046	206.7	-0.2858
13.97	-0.046	206.6	-0.2867
14.00	-0.046	206.5	-0.2894
14.03	-0.047	206.5	-0.2911
14.07	-0.048	206.4	-0.2929
14.10	-0.049	206.3	-0.2947
14.13	-0.05	206.3	-0.2947
14.17	-0.05	206.3	-0.2965
14.20	-0.05	206.2	-0.2991
14.23	-0.051	206.1	-0.3009
14.27	-0.052	206.1	-0.3027
14.30	-0.052	206	-0.3045
14.33	-0.053	205.9	-0.3062
14.37	-0.055	205.8	-0.3062
14.40	-0.055	205.8	-0.3089
14.43	-0.054	205.8	-0.3098
14.47	-0.055	205.7	-0.3116
14.50	-0.056	205.6	-0.3142
14.55	-0.057	205.5	-0.316
14.58	-0.057	205.5	-0.3169
14.60	-0.058	205.4	-0.3196
14.63	-0.058	205.4	-0.3204
14.67	-0.059	205.3	-0.3222
14.70	-0.06	205.2	-0.3222
14.73	-0.06	205.2	-0.3249
14.77	-0.06	205.2	-0.3267
14.80	-0.061	205.1	-0.3293
14.83	-0.062	205	-0.332
14.87	-0.063	204.9	-0.3346
14.90	-0.062	204.9	-0.3364
14.93	-0.064	204.7	-0.3364
14.97	-0.063	204.7	-0.3382
15.00	-0.063	204.7	-0.34
15.03	-0.065	204.6	-0.3417

Prova triassiale ciclica SNME01-C3			
pressione di confinamento (kPa)		380	
deviatore ciclico (kPa)		80	
frequenza (hz)		0.00071429	
tempo	cella di carico	u	LVDT
(min)	kN	(kPa)	δ (mm)
15.07	-0.066	204.5	-0.3426
15.10	-0.066	204.5	-0.3444
15.13	-0.066	204.4	-0.3462
15.17	-0.067	204.4	-0.3462
15.20	-0.067	204.4	-0.348
15.23	-0.067	204.3	-0.3497
15.27	-0.068	204.2	-0.3515
15.30	-0.069	204.2	-0.3524
15.33	-0.069	204.1	-0.3542
15.37	-0.069	204	-0.3551
15.40	-0.07	204	-0.3551
15.43	-0.071	204	-0.3568
15.47	-0.071	203.9	-0.3586
15.50	-0.071	203.9	-0.3604
15.53	-0.071	203.8	-0.3613
15.57	-0.072	203.7	-0.363
15.60	-0.072	203.6	-0.3639
15.63	-0.073	203.6	-0.3639
15.67	-0.073	203.6	-0.3657
15.70	-0.073	203.5	-0.3666
15.73	-0.074	203.5	-0.3684
15.77	-0.075	203.4	-0.3701
15.80	-0.074	203.4	-0.371
15.83	-0.075	203.3	-0.3728
15.87	-0.076	203.3	-0.3728
15.90	-0.076	203.3	-0.3737
15.93	-0.076	203.2	-0.3746
15.97	-0.076	203.2	-0.3764
16.02	-0.077	203.1	-0.3772
16.05	-0.077	203.1	-0.3781
16.07	-0.077	203	-0.3799
16.10	-0.078	203	-0.3808
16.13	-0.078	202.9	-0.3826
16.17	-0.078	202.9	-0.3835
16.20	-0.079	202.8	-0.3835
16.23	-0.079	202.8	-0.3843
16.27	-0.079	202.8	-0.3852
16.30	-0.079	202.8	-0.3861
16.33	-0.079	202.7	-0.3879
16.37	-0.08	202.7	-0.3888
16.40	-0.08	202.6	-0.3897
16.43	-0.08	202.6	-0.3897
16.47	-0.081	202.6	-0.3906
16.50	-0.081	202.5	-0.3914
16.53	-0.081	202.5	-0.3923
16.57	-0.081	202.5	-0.3932
16.60	-0.082	202.4	-0.395
16.63	-0.081	202.4	-0.395
16.67	-0.082	202.4	-0.395
16.70	-0.082	202.4	-0.3968
16.73	-0.082	202.3	-0.3968
16.77	-0.082	202.3	-0.3977
16.80	-0.082	202.3	-0.3986
16.83	-0.082	202.2	-0.3986
16.87	-0.083	202.2	-0.3994
16.90	-0.083	202.2	-0.3994
16.93	-0.083	202.2	-0.4003
16.97	-0.083	202.2	-0.4012

Prova triassiale ciclica SNME01-C3			
pressione di confinamento (kPa)		380	
deviatore ciclico (kPa)		80	
frequenza (hz)		0.00071429	
tempo	cella di carico	u	LVDT
(min)	kN	(kPa)	δ (mm)
17.00	-0.083	202.1	-0.4021
17.03	-0.083	202.1	-0.403
17.07	-0.083	202.1	-0.403
17.10	-0.084	202	-0.4039
17.13	-0.084	202	-0.4039
17.17	-0.084	202	-0.4048
17.20	-0.084	202	-0.4057
17.23	-0.083	202	-0.4065
17.27	-0.084	202	-0.4065
17.30	-0.084	201.9	-0.4074
17.33	-0.084	201.9	-0.4083
17.37	-0.084	201.9	-0.4083
17.40	-0.084	201.9	-0.4092
17.45	-0.084	201.9	-0.4101
17.48	-0.084	201.8	-0.4101
17.50	-0.085	201.8	-0.4101
17.53	-0.085	201.8	-0.411
17.57	-0.084	201.8	-0.411
17.60	-0.084	201.8	-0.4119
17.63	-0.084	201.8	-0.4119
17.67	-0.084	201.8	-0.4128
17.70	-0.084	201.8	-0.4128
17.73	-0.084	201.8	-0.4128
17.77	-0.084	201.8	-0.4136
17.80	-0.084	201.7	-0.4136
17.83	-0.084	201.7	-0.4136
17.87	-0.084	201.7	-0.4145
17.90	-0.083	201.7	-0.4145
17.93	-0.083	201.7	-0.4145
17.97	-0.083	201.7	-0.4145
18.00	-0.083	201.7	-0.4154
18.03	-0.084	201.7	-0.4154
18.07	-0.083	201.7	-0.4154
18.10	-0.083	201.7	-0.4163
18.13	-0.083	201.7	-0.4163
18.17	-0.083	201.7	-0.4163
18.20	-0.082	201.7	-0.4163
18.23	-0.082	201.7	-0.4163
18.27	-0.083	201.7	-0.4163
18.30	-0.082	201.7	-0.4172
18.33	-0.082	201.7	-0.4172
18.37	-0.082	201.7	-0.4172
18.40	-0.082	201.7	-0.4172
18.43	-0.082	201.7	-0.4172
18.47	-0.082	201.8	-0.4172
18.50	-0.081	201.8	-0.4172
18.53	-0.081	201.8	-0.4172
18.57	-0.08	201.8	-0.4172
18.60	-0.08	201.8	-0.4172
18.63	-0.08	201.8	-0.4172
18.67	-0.08	201.8	-0.4172
18.70	-0.08	201.8	-0.4181
18.73	-0.08	201.8	-0.4172
18.77	-0.079	201.8	-0.4172
18.80	-0.079	201.8	-0.4172
18.83	-0.079	201.9	-0.4172
18.87	-0.078	201.9	-0.4172
18.92	-0.078	201.9	-0.4172

Prova triassiale ciclica SNME01-C3			
pressione di confinamento (kPa)		380	
deviatore ciclico (kPa)		80	
frequenza (hz)		0.00071429	
tempo	cella di carico	u	LVDT
(min)	kN	(kPa)	δ (mm)
18.95	-0.078	201.9	-0.4172
18.97	-0.077	201.9	-0.4172
19.00	-0.077	201.9	-0.4172
19.03	-0.077	201.9	-0.4172
19.07	-0.077	202	-0.4172
19.10	-0.076	202	-0.4172
19.13	-0.076	202	-0.4172
19.17	-0.076	202	-0.4172
19.20	-0.075	202	-0.4172
19.23	-0.074	202	-0.4172
19.27	-0.074	202.1	-0.4163
19.30	-0.074	202.1	-0.4163
19.33	-0.074	202.1	-0.4163
19.37	-0.073	202.1	-0.4163
19.40	-0.073	202.2	-0.4163
19.43	-0.073	202.2	-0.4163
19.47	-0.072	202.2	-0.4163
19.50	-0.072	202.2	-0.4154
19.53	-0.072	202.2	-0.4154
19.57	-0.071	202.3	-0.4154
19.60	-0.071	202.3	-0.4154
19.63	-0.07	202.3	-0.4154
19.67	-0.069	202.4	-0.4154
19.70	-0.069	202.4	-0.4145
19.73	-0.069	202.4	-0.4145
19.77	-0.069	202.4	-0.4145
19.80	-0.068	202.4	-0.4136
19.83	-0.067	202.5	-0.4136
19.87	-0.067	202.5	-0.4136
19.90	-0.066	202.6	-0.4136
19.93	-0.066	202.6	-0.4128
19.97	-0.066	202.6	-0.4128
20.00	-0.066	202.6	-0.4128
20.03	-0.064	202.7	-0.4119
20.07	-0.064	202.7	-0.4119
20.10	-0.064	202.8	-0.4119
20.13	-0.063	202.8	-0.4119
20.17	-0.062	202.8	-0.411
20.20	-0.062	202.8	-0.411
20.23	-0.061	202.9	-0.4101
20.27	-0.061	202.9	-0.4101
20.30	-0.06	203	-0.4101
20.35	-0.06	203	-0.4092
20.38	-0.059	203.1	-0.4092
20.40	-0.059	203.1	-0.4092
20.43	-0.058	203.2	-0.4083
20.47	-0.057	203.2	-0.4083
20.50	-0.056	203.2	-0.4074
20.53	-0.056	203.3	-0.4074
20.57	-0.056	203.3	-0.4074
20.60	-0.055	203.3	-0.4074
20.63	-0.055	203.4	-0.4065
20.67	-0.054	203.4	-0.4057
20.70	-0.052	203.5	-0.4057
20.73	-0.053	203.5	-0.4057
20.77	-0.053	203.5	-0.4048
20.80	-0.052	203.6	-0.4048
20.83	-0.051	203.6	-0.4039

Prova triassiale ciclica SNME01-C3			
pressione di confinamento (kPa)		380	
deviatore ciclico (kPa)		80	
frequenza (hz)		0.00071429	
tempo	cella di carico	u	LVDT
(min)	kN	(kPa)	δ (mm)
20.87	-0.05	203.7	-0.4039
20.90	-0.05	203.8	-0.403
20.93	-0.049	203.8	-0.403
20.97	-0.048	203.8	-0.403
21.00	-0.048	203.9	-0.4021
21.03	-0.047	204	-0.4012
21.07	-0.046	204	-0.4003
21.10	-0.046	204.1	-0.4003
21.13	-0.046	204.1	-0.3994
21.17	-0.044	204.2	-0.3994
21.20	-0.043	204.2	-0.3994
21.23	-0.043	204.3	-0.3986
21.27	-0.043	204.3	-0.3986
21.30	-0.041	204.4	-0.3977
21.33	-0.041	204.5	-0.3977
21.37	-0.041	204.5	-0.3968
21.40	-0.039	204.6	-0.3968
21.43	-0.039	204.6	-0.3959
21.47	-0.039	204.7	-0.395
21.50	-0.038	204.7	-0.395
21.53	-0.036	204.8	-0.3932
21.57	-0.036	204.9	-0.3932
21.60	-0.036	204.9	-0.3923
21.63	-0.034	205	-0.3923
21.67	-0.034	205	-0.3914
21.70	-0.034	205.1	-0.3906
21.73	-0.033	205.2	-0.3897
21.77	-0.032	205.3	-0.3888
21.82	-0.031	205.3	-0.3879
21.85	-0.03	205.4	-0.387
21.87	-0.03	205.4	-0.3861
21.90	-0.029	205.5	-0.3852
21.93	-0.028	205.6	-0.3843
21.97	-0.026	205.7	-0.3843
22.00	-0.027	205.7	-0.3835
22.03	-0.027	205.7	-0.3826
22.07	-0.026	205.9	-0.3808
22.10	-0.023	206	-0.3799
22.13	-0.024	206	-0.379
22.17	-0.023	206.1	-0.3772
22.20	-0.021	206.2	-0.3772
22.23	-0.021	206.2	-0.3755
22.27	-0.021	206.3	-0.3746
22.30	-0.02	206.4	-0.3737
22.33	-0.019	206.5	-0.3719
22.37	-0.018	206.6	-0.3701
22.40	-0.018	206.6	-0.3684
22.43	-0.016	206.7	-0.3684
22.47	-0.016	206.7	-0.3666
22.50	-0.016	206.8	-0.3657
22.53	-0.015	206.9	-0.3639
22.57	-0.013	207.1	-0.3613
22.60	-0.013	207.1	-0.3604
22.63	-0.012	207.2	-0.3577
22.67	-0.01	207.4	-0.3577
22.70	-0.01	207.4	-0.3551
22.73	-0.01	207.4	-0.3533
22.77	-0.01	207.5	-0.3497

Prova triassiale ciclica SNME01-C3			
pressione di confinamento (kPa)		380	
deviatore ciclico (kPa)		80	
frequenza (hz)		0.00071429	
tempo	cella di carico	u	LVDT
(min)	kN	(kPa)	δ (mm)
22.80	-0.008	207.7	-0.3462
22.83	-0.007	207.8	-0.3426
22.87	-0.006	208	-0.3382
22.90	-0.005	208.1	-0.3382
22.93	-0.005	208.1	-0.3346
22.97	-0.005	208.2	-0.3311
23.00	-0.003	208.3	-0.3267
23.03	-0.002	208.4	-0.3222
23.07	-0.002	208.5	-0.3187
23.10	-0.001	208.6	-0.3151
23.13	0	208.8	-0.3151
23.17	0.001	208.8	-0.3107
23.20	0.001	208.9	-0.3053
23.23	0.002	209	-0.2991
23.28	0.004	209.2	-0.2938
23.30	0.004	209.3	-0.2894
23.33	0.004	209.4	-0.284
23.37	0.006	209.5	-0.2787
23.40	0.006	209.6	-0.2725
23.43	0.007	209.7	-0.2672
23.47	0.009	209.9	-0.2672
23.50	0.01	209.9	-0.2627
23.53	0.01	210	-0.2601
23.57	0.01	210.1	-0.2565
23.60	0.012	210.2	-0.2539
23.63	0.011	210.3	-0.2459
23.67	0.012	210.4	-0.2361
23.70	0.015	210.6	-0.2361
23.73	0.015	210.6	-0.2255
23.77	0.015	210.7	-0.2175
23.80	0.015	210.8	-0.2104
23.83	0.017	211	-0.2015
23.87	0.018	211.1	-0.1935
23.90	0.018	211.2	-0.1846
23.93	0.02	211.4	-0.1846
23.97	0.02	211.4	-0.1731
24.00	0.02	211.5	-0.1633
24.03	0.021	211.6	-0.1536
24.07	0.023	211.8	-0.1438
24.10	0.023	211.9	-0.134
24.13	0.024	212	-0.1243
24.17	0.026	212.3	-0.1243
24.20	0.026	212.3	-0.1145
24.23	0.026	212.3	-0.1074
24.27	0.027	212.5	-0.0994
24.30	0.029	212.6	-0.0923
24.33	0.029	212.7	-0.0852
24.37	0.029	212.8	-0.0799
24.40	0.031	212.9	-0.0799
24.43	0.031	212.9	-0.0728
24.47	0.031	213	-0.0675
24.50	0.032	213.1	-0.0612
24.53	0.034	213.2	-0.055
24.57	0.035	213.3	-0.0497
24.60	0.035	213.4	-0.0453
24.63	0.036	213.5	-0.0453
24.67	0.038	213.5	-0.0399
24.72	0.037	213.7	-0.0311

Prova triassiale ciclica SNME01-C3			
pressione di confinamento (kPa)		380	
deviatore ciclico (kPa)		80	
frequenza (hz)		0.00071429	
tempo	cella di carico	u	LVDT
(min)	kN	(kPa)	δ (mm)
24.75	0.038	213.8	-0.0311
24.77	0.039	213.8	-0.0266
24.80	0.039	213.9	-0.0231
24.83	0.04	214	-0.0186
24.87	0.041	214.1	-0.0142
24.90	0.043	214.2	-0.0107
24.93	0.042	214.3	-0.0071
24.97	0.047	214.4	-0.0071
25.00	0.045	214.4	-0.0036
25.03	0.045	214.4	-0.0018
25.07	0.043	214.4	-0.0009
25.10	0.046	214.6	0.0009
25.13	0.047	214.6	0.0036
25.17	0.047	214.7	0.0044
25.20	0.049	214.8	0.0044
25.23	0.05	214.8	0.0062
25.27	0.05	214.9	0.008
25.30	0.05	214.9	0.0098
25.33	0.052	215	0.0115
25.37	0.051	215.1	0.0124
25.40	0.053	215.2	0.0142
25.43	0.053	215.3	0.0142
25.47	0.055	215.3	0.0151
25.50	0.055	215.3	0.0169
25.53	0.055	215.4	0.0178
25.57	0.056	215.5	0.0186
25.60	0.057	215.6	0.0204
25.63	0.057	215.6	0.0213
25.67	0.058	215.7	0.0213
25.70	0.06	215.7	0.0231
25.73	0.06	215.8	0.024
25.77	0.06	215.8	0.0257
25.80	0.061	215.9	0.0266
25.83	0.061	216	0.0284
25.87	0.062	216.1	0.0293
25.90	0.063	216.2	0.0293
25.93	0.064	216.2	0.0302
25.97	0.064	216.2	0.032
26.00	0.064	216.3	0.0328
26.03	0.065	216.4	0.0337
26.07	0.066	216.5	0.0346
26.10	0.066	216.5	0.0355
26.13	0.067	216.6	0.0355
26.18	0.068	216.7	0.0382
26.22	0.068	216.8	0.0391
26.23	0.069	216.8	0.0391
26.27	0.069	216.8	0.0399
26.30	0.069	216.9	0.0408
26.33	0.07	217	0.0417
26.37	0.072	217	0.0426
26.40	0.071	217.1	0.0435
26.43	0.073	217.2	0.0444
26.47	0.072	217.2	0.0444
26.50	0.073	217.2	0.0453
26.53	0.073	217.3	0.0462
26.57	0.074	217.4	0.047
26.60	0.075	217.4	0.0479
26.63	0.076	217.5	0.0497

Prova triassiale ciclica SNME01-C3			
pressione di confinamento (kPa)		380	
deviatore ciclico (kPa)		80	
frequenza (hz)		0.00071429	
tempo	cella di carico	u	LVDT
(min)	kN	(kPa)	δ (mm)
26.67	0.076	217.6	0.0506
26.70	0.077	217.7	0.0506
26.73	0.077	217.7	0.0515
26.77	0.077	217.7	0.0524
26.80	0.077	217.8	0.0533
26.83	0.078	217.9	0.0541
26.87	0.079	217.9	0.055
26.90	0.079	218	0.055
26.93	0.081	218.1	0.055
26.97	0.08	218.1	0.0559
27.00	0.08	218.1	0.0559
27.03	0.082	218.2	0.0577
27.07	0.081	218.2	0.0577
27.10	0.082	218.3	0.0586
27.13	0.082	218.4	0.0595
27.17	0.083	218.4	0.0595
27.20	0.083	218.4	0.0604
27.23	0.083	218.5	0.0612
27.27	0.084	218.6	0.0621
27.30	0.085	218.7	0.063
27.33	0.084	218.7	0.063
27.37	0.085	218.8	0.0639
27.40	0.086	218.8	0.0639
27.43	0.087	218.8	0.0648
27.47	0.087	218.9	0.0657
27.50	0.087	219	0.0666
27.53	0.087	219	0.0675
27.57	0.087	219.1	0.0675
27.62	0.087	219.1	0.0683
27.65	0.088	219.2	0.0692
27.67	0.089	219.3	0.0692
27.70	0.088	219.3	0.0701
27.73	0.089	219.4	0.0701
27.77	0.089	219.4	0.071
27.80	0.089	219.4	0.0719
27.83	0.09	219.5	0.0719
27.87	0.09	219.5	0.0728
27.90	0.091	219.6	0.0737
27.93	0.091	219.7	0.0737
27.97	0.091	219.7	0.0737
28.00	0.091	219.7	0.0746
28.03	0.091	219.8	0.0746
28.07	0.091	219.8	0.0754
28.10	0.092	219.9	0.0763
28.13	0.092	219.9	0.0763
28.17	0.094	220	0.0772
28.20	0.092	220.1	0.0772
28.23	0.093	220.1	0.0772
28.27	0.093	220.1	0.0781
28.30	0.093	220.2	0.0781
28.33	0.094	220.2	0.079
28.37	0.094	220.3	0.079
28.40	0.094	220.3	0.0799
28.43	0.094	220.4	0.0799
28.47	0.095	220.4	0.0799
28.50	0.095	220.4	0.0808
28.53	0.095	220.5	0.0808
28.57	0.094	220.5	0.0817

Prova triassiale ciclica SNME01-C3			
pressione di confinamento (kPa)		380	
deviatore ciclico (kPa)		80	
frequenza (hz)		0.00071429	
tempo	cella di carico	u	LVDT
(min)	kN	(kPa)	δ (mm)
28.60	0.095	220.6	0.0817
28.63	0.095	220.6	0.0826
28.67	0.095	220.7	0.0826
28.70	0.095	220.7	0.0826
28.73	0.095	220.7	0.0826
28.77	0.095	220.8	0.0834
28.80	0.095	220.8	0.0834
28.83	0.096	220.9	0.0834
28.87	0.095	220.9	0.0843
28.90	0.096	221	0.0843
28.93	0.095	221	0.0843
28.97	0.095	221	0.0843
29.00	0.098	221.1	0.0852
29.03	0.097	221.1	0.0852
29.08	0.095	221.1	0.0852
29.12	0.096	221.2	0.0852
29.13	0.096	221.2	0.0861
29.17	0.095	221.2	0.0861
29.20	0.096	221.3	0.0861
29.23	0.096	221.3	0.0861
29.27	0.096	221.3	0.0861
29.30	0.096	221.4	0.0861
29.33	0.096	221.4	0.0861
29.37	0.096	221.4	0.087
29.40	0.094	221.4	0.0861
29.43	0.097	221.5	0.0879
29.47	0.098	221.6	0.0879
29.50	0.096	221.6	0.0879
29.53	0.096	221.6	0.087
29.57	0.092	221.5	0.087
29.60	0.098	221.7	0.0879
29.63	0.096	221.7	0.0879
29.67	0.096	221.7	0.0879
29.70	0.091	221.6	0.0879
29.73	0.098	221.6	0.0879
29.77	0.098	221.8	0.0888
29.80	0.095	221.8	0.0879
29.83	0.094	221.8	0.0879
29.87	0.094	221.8	0.0879
29.90	0.092	221.7	0.087
29.93	0.096	221.9	0.087
29.97	0.094	221.9	0.0888
30.00	0.094	221.9	0.087
30.03	0.094	221.9	0.0879
30.07	0.093	221.9	0.0879
30.10	0.089	221.8	0.087
30.13	0.096	222	0.0888
30.17	0.095	222	0.0888
30.20	0.094	222	0.0888
30.23	0.094	222	0.0879
30.27	0.092	222	0.0879
30.30	0.092	222	0.0879
30.33	0.092	222	0.0879
30.37	0.092	222.1	0.0879
30.40	0.091	222.1	0.0879
30.43	0.091	222.1	0.0879
30.47	0.091	222.1	0.0879
30.52	0.091	222.1	0.0879

Prova triassiale ciclica SNME01-C3			
pressione di confinamento (kPa)		380	
deviatore ciclico (kPa)		80	
frequenza (hz)		0.00071429	
tempo	cella di carico	u	LVDT
(min)	kN	(kPa)	δ (mm)
30.55	0.088	222.1	0.0879
30.57	0.088	222.1	0.087
30.60	0.092	222.2	0.0879
30.63	0.091	222.2	0.0879
30.67	0.09	222.2	0.0861
30.70	0.088	222.2	0.087
30.73	0.088	222.2	0.087
30.77	0.088	222.2	0.087
30.80	0.088	222.2	0.0861
30.83	0.088	222.2	0.087
30.87	0.087	222.2	0.087
30.90	0.087	222.2	0.0861
30.93	0.086	222.2	0.0861
30.97	0.086	222.2	0.0861
31.00	0.085	222.2	0.0861
31.03	0.085	222.2	0.0861
31.07	0.085	222.2	0.0861
31.10	0.084	222.2	0.0852
31.13	0.084	222.2	0.0852
31.17	0.083	222.2	0.0852
31.20	0.083	222.2	0.0852
31.23	0.083	222.2	0.0843
31.27	0.083	222.2	0.0843
31.30	0.082	222.2	0.0843
31.33	0.081	222.2	0.0843
31.37	0.079	222.2	0.0834
31.40	0.083	222.3	0.0843
31.43	0.081	222.3	0.0843
31.47	0.079	222.3	0.0843
31.50	0.079	222.2	0.0826
31.53	0.078	222.2	0.0834
31.57	0.079	222.3	0.0834
31.60	0.078	222.2	0.0826
31.63	0.077	222.2	0.0826
31.67	0.077	222.2	0.0826
31.70	0.076	222.2	0.0817
31.73	0.076	222.2	0.0817
31.77	0.075	222.2	0.0817
31.80	0.074	222.2	0.0808
31.83	0.071	222.1	0.0808
31.87	0.075	222.2	0.0808
31.90	0.075	222.2	0.0808
31.93	0.072	222.2	0.0808
31.98	0.073	222.1	0.0799
32.02	0.068	222	0.0799
32.03	0.071	222	0.079
32.07	0.071	222.1	0.079
32.10	0.07	222.1	0.0781
32.13	0.069	222.1	0.0781
32.17	0.068	222.1	0.0781
32.20	0.068	222.1	0.0772
32.23	0.067	222	0.0772
32.27	0.066	222	0.0772
32.30	0.066	222	0.0763
32.33	0.066	222	0.0763
32.37	0.065	222	0.0754
32.40	0.064	222	0.0754
32.43	0.064	221.9	0.0746

Prova triassiale ciclica SNME01-C3			
ensione di confinamento (kPa)		380	
deviatore ciclico (kPa)		80	
frequenza (hz)		0.00071429	
tempo	cella di carico	u	LVDT
(min)	kN	(kPa)	δ (mm)
32.47	0.063	221.9	0.0746
32.50	0.062	221.9	0.0746
32.53	0.062	221.9	0.0737
32.57	0.062	221.9	0.0737
32.60	0.061	221.9	0.0728
32.63	0.06	221.8	0.0728
32.67	0.059	221.8	0.0719
32.70	0.058	221.8	0.0719
32.73	0.057	221.8	0.071
32.77	0.057	221.7	0.0701
32.80	0.057	221.7	0.0701
32.83	0.056	221.7	0.0692
32.87	0.055	221.7	0.0683
32.90	0.055	221.7	0.0683
32.93	0.054	221.6	0.0683
32.97	0.053	221.6	0.0675
33.00	0.053	221.6	0.0675
33.03	0.052	221.6	0.0657
33.07	0.051	221.5	0.0648
33.10	0.051	221.5	0.0648
33.13	0.05	221.5	0.0639
33.17	0.048	221.4	0.0639
33.20	0.048	221.4	0.063
33.23	0.048	221.4	0.0621
33.27	0.047	221.4	0.0612
33.30	0.046	221.3	0.0604
33.33	0.045	221.2	0.0604
33.37	0.045	221.2	0.0595
33.40	0.044	221.2	0.0595
33.45	0.043	221.2	0.0577
33.48	0.043	221.1	0.0568
33.50	0.042	221.1	0.0568
33.53	0.04	221.1	0.0559
33.57	0.04	221	0.0559
33.60	0.04	221	0.055
33.63	0.039	220.9	0.0541
33.67	0.038	220.9	0.0533
33.70	0.037	220.9	0.0524
33.73	0.036	220.8	0.0524
33.77	0.035	220.8	0.0515
33.80	0.035	220.8	0.0497
33.83	0.034	220.7	0.0488
33.87	0.034	220.7	0.0479
33.90	0.032	220.7	0.047
33.93	0.032	220.6	0.0462
33.97	0.031	220.6	0.0462
34.00	0.03	220.6	0.0453
34.03	0.03	220.5	0.0444
34.07	0.03	220.5	0.0435
34.10	0.028	220.4	0.0417
34.13	0.027	220.3	0.0408
34.17	0.027	220.3	0.0399
34.20	0.026	220.3	0.0399
34.23	0.025	220.3	0.0391
34.27	0.025	220.2	0.0373
34.30	0.024	220.1	0.0364
34.33	0.022	220.1	0.0346
34.37	0.021	220	0.0337

Prova triassiale ciclica SNME01-C3			
ensione di confinamento (kPa)		380	
deviatore ciclico (kPa)		80	
frequenza (hz)		0.00071429	
tempo	cella di carico	u	LVDT
(min)	kN	(kPa)	δ (mm)
34.40	0.021	220	0.0328
34.43	0.02	219.9	0.0328
34.47	0.018	219.9	0.0311
34.50	0.018	219.9	0.0302
34.53	0.019	219.8	0.0293
34.57	0.017	219.8	0.0275
34.60	0.016	219.7	0.0266
34.63	0.016	219.7	0.0249
34.67	0.014	219.6	0.0249
34.70	0.013	219.6	0.024
34.73	0.013	219.5	0.0222
34.77	0.012	219.5	0.0213
34.80	0.011	219.4	0.0204
34.83	0.011	219.4	0.0186
34.88	0.01	219.3	0.0178
34.92	0.009	219.3	0.016
34.93	0.008	219.2	0.0151
34.97	0.007	219.1	0.0133
35.00	0.007	219.1	0.0133
35.03	0.005	219.1	0.0124
35.07	0.005	219	0.0107
35.10	0.005	219	0.0098
35.13	0.003	218.9	0.008
35.17	0.002	218.9	0.0071
35.20	0.001	218.8	0.0053
35.23	0	218.7	0.0053
35.27	-0.001	218.7	0.0036
35.30	-0.001	218.7	0.0018
35.33	-0.001	218.6	0.0009
35.37	-0.002	218.5	-0.0018
35.40	-0.003	218.4	-0.0036
35.43	-0.004	218.4	-0.0053
35.47	-0.006	218.2	-0.0053
35.50	-0.006	218.2	-0.0089
35.53	-0.006	218.2	-0.0115
35.57	-0.007	218.1	-0.0142
35.60	-0.008	218	-0.0178
35.63	-0.009	217.9	-0.0213
35.67	-0.01	217.9	-0.0257
35.70	-0.011	217.8	-0.0257
35.73	-0.012	217.8	-0.0302
35.77	-0.012	217.7	-0.0364
35.80	-0.013	217.6	-0.0444
35.83	-0.013	217.5	-0.0541
35.87	-0.014	217.4	-0.071
35.90	-0.015	217.2	-0.1074
35.93	-0.016	217	-0.1074
35.97	-0.018	217	-0.1562
36.00	-0.018	216.8	-0.182
36.03	-0.017	216.6	-0.2006
36.07	-0.019	216.4	-0.2166
36.10	-0.02	216.2	-0.2255
36.13	-0.021	216.1	-0.2308
36.17	-0.022	215.9	-0.2308
36.20	-0.022	215.9	-0.2361
36.23	-0.022	215.9	-0.2406
36.27	-0.024	215.7	-0.2468
36.30	-0.025	215.6	-0.2503

Prova triassiale ciclica SNME01-C3			
pressione di confinamento (kPa)		380	
deviatore ciclico (kPa)		80	
frequenza (hz)		0.00071429	
tempo	cella di carico	u	LVDT
(min)	kN	(kPa)	δ (mm)
36.35	-0.026	215.5	-0.2548
36.38	-0.026	215.4	-0.2574
36.40	-0.027	215.4	-0.261
36.43	-0.028	215.3	-0.2645
36.47	-0.028	215.2	-0.2672
36.50	-0.029	215.1	-0.2672
36.53	-0.03	215.1	-0.2707
36.57	-0.03	215	-0.2734
36.60	-0.031	214.9	-0.2778
36.63	-0.032	214.8	-0.2805
36.67	-0.033	214.7	-0.284
36.70	-0.033	214.6	-0.2876
36.73	-0.034	214.5	-0.2876
36.77	-0.036	214.5	-0.2911
36.80	-0.036	214.4	-0.2938
36.83	-0.036	214.3	-0.2956
36.87	-0.037	214.2	-0.2982
36.90	-0.038	214.1	-0.3009
36.93	-0.038	214.1	-0.3036
36.97	-0.04	213.9	-0.3036
37.00	-0.04	213.9	-0.3062
37.03	-0.04	213.8	-0.3107
37.07	-0.04	213.8	-0.3124
37.10	-0.042	213.6	-0.316
37.13	-0.043	213.5	-0.3196
37.17	-0.043	213.4	-0.3222
37.20	-0.044	213.4	-0.3222
37.23	-0.045	213.4	-0.324
37.27	-0.045	213.3	-0.3267
37.30	-0.046	213.2	-0.3293
37.33	-0.047	213.1	-0.332
37.37	-0.047	213	-0.3346
37.40	-0.048	212.9	-0.3373
37.43	-0.049	212.8	-0.3373
37.47	-0.05	212.6	-0.34
37.50	-0.05	212.6	-0.3426
37.53	-0.05	212.6	-0.3444
37.57	-0.051	212.5	-0.3462
37.60	-0.052	212.4	-0.3488
37.63	-0.052	212.3	-0.3506
37.67	-0.053	212.2	-0.3506
37.70	-0.054	212.2	-0.3524
37.73	-0.054	212.1	-0.3542
37.78	-0.055	212	-0.3559
37.82	-0.055	211.9	-0.3577
37.83	-0.055	211.9	-0.3595
37.87	-0.056	211.8	-0.3613
37.90	-0.058	211.7	-0.363
37.93	-0.057	211.6	-0.3648
37.97	-0.058	211.6	-0.3666
38.00	-0.059	211.5	-0.3666
38.03	-0.06	211.4	-0.3684
38.07	-0.06	211.4	-0.3693
38.10	-0.061	211.3	-0.371
38.13	-0.06	211.3	-0.3719
38.17	-0.062	211.2	-0.3737
38.20	-0.062	211.1	-0.3755
38.23	-0.063	211	-0.3755

Prova triassiale ciclica SNME01-C3			
pressione di confinamento (kPa)		380	
deviatore ciclico (kPa)		80	
frequenza (hz)		0.00071429	
tempo	cella di carico	u	LVDT
(min)	kN	(kPa)	δ (mm)
38.27	-0.063	211	-0.3764
38.30	-0.063	211	-0.3781
38.33	-0.064	210.9	-0.3799
38.37	-0.064	210.8	-0.3808
38.40	-0.066	210.7	-0.3826
38.43	-0.065	210.7	-0.3843
38.47	-0.066	210.6	-0.3843
38.50	-0.067	210.5	-0.3852
38.53	-0.067	210.5	-0.387
38.57	-0.067	210.5	-0.3879
38.60	-0.068	210.4	-0.3897
38.63	-0.069	210.3	-0.3914
38.67	-0.069	210.2	-0.3923
38.70	-0.07	210.1	-0.3923
38.73	-0.07	210.1	-0.3941
38.77	-0.07	210.1	-0.395
38.80	-0.071	210	-0.3959
38.83	-0.071	210	-0.3977
38.87	-0.071	209.9	-0.3986
38.90	-0.073	209.8	-0.3994
38.93	-0.072	209.8	-0.3994
38.97	-0.073	209.7	-0.4003
39.00	-0.073	209.7	-0.4012
39.03	-0.073	209.6	-0.403
39.07	-0.074	209.6	-0.4039
39.10	-0.074	209.5	-0.4048
39.13	-0.075	209.4	-0.4057
39.17	-0.075	209.4	-0.4057
39.20	-0.076	209.3	-0.4074
39.25	-0.076	209.3	-0.4092
39.28	-0.075	209.3	-0.4092
39.30	-0.076	209.2	-0.4101
39.33	-0.076	209.2	-0.411
39.37	-0.077	209.1	-0.4119
39.40	-0.078	209	-0.4136
39.43	-0.078	209	-0.4145
39.47	-0.078	209	-0.4154
39.50	-0.077	208.9	-0.4154
39.53	-0.079	208.8	-0.4163
39.57	-0.079	208.8	-0.4172
39.60	-0.079	208.8	-0.4181
39.63	-0.079	208.8	-0.419
39.67	-0.079	208.7	-0.4199
39.70	-0.079	208.7	-0.4207
39.73	-0.081	208.6	-0.4207
39.77	-0.08	208.6	-0.4216
39.80	-0.08	208.6	-0.4216
39.83	-0.081	208.5	-0.4225
39.87	-0.081	208.5	-0.4234
39.90	-0.081	208.4	-0.4243
39.93	-0.081	208.4	-0.4252
39.97	-0.081	208.4	-0.4252
40.00	-0.082	208.4	-0.4261
40.03	-0.082	208.4	-0.4261
40.07	-0.082	208.3	-0.427
40.10	-0.082	208.3	-0.4278
40.13	-0.083	208.2	-0.4287
40.17	-0.083	208.2	-0.4296

Prova triassiale ciclica SNME01-C3			
pressione di confinamento (kPa)		380	
deviatore ciclico (kPa)		80	
frequenza (hz)		0.00071429	
tempo	cella di carico	u	LVDT
(min)	kN	(kPa)	δ (mm)
40.20	-0.083	208.2	-0.4296
40.23	-0.083	208.1	-0.4296
40.27	-0.083	208.1	-0.4305
40.30	-0.083	208.1	-0.4314
40.33	-0.083	208.1	-0.4314
40.37	-0.083	208.1	-0.4323
40.40	-0.084	208	-0.4332
40.43	-0.084	208	-0.4332
40.47	-0.084	207.9	-0.4341
40.50	-0.084	207.9	-0.4341
40.53	-0.083	207.9	-0.4341
40.57	-0.084	207.8	-0.4349
40.60	-0.084	207.8	-0.4358
40.63	-0.084	207.8	-0.4358
40.68	-0.084	207.8	-0.4367
40.72	-0.084	207.8	-0.4367
40.73	-0.084	207.7	-0.4376
40.77	-0.084	207.7	-0.4376
40.80	-0.084	207.7	-0.4376
40.83	-0.084	207.7	-0.4376
40.87	-0.084	207.7	-0.4385
40.90	-0.084	207.6	-0.4385
40.93	-0.084	207.6	-0.4385
40.97	-0.084	207.6	-0.4394
41.00	-0.084	207.6	-0.4394
41.03	-0.084	207.6	-0.4394
41.07	-0.084	207.6	-0.4403
41.10	-0.084	207.6	-0.4403
41.13	-0.084	207.6	-0.4403
41.17	-0.084	207.5	-0.4412
41.20	-0.083	207.5	-0.4412
41.23	-0.083	207.5	-0.4412
41.27	-0.084	207.5	-0.4412
41.30	-0.084	207.5	-0.4412
41.33	-0.084	207.5	-0.4412
41.37	-0.084	207.5	-0.442
41.40	-0.083	207.5	-0.442
41.43	-0.083	207.5	-0.442
41.47	-0.083	207.5	-0.442
41.50	-0.083	207.5	-0.442
41.53	-0.083	207.5	-0.442
41.57	-0.083	207.5	-0.442
41.60	-0.083	207.5	-0.442
41.63	-0.082	207.5	-0.442
41.67	-0.082	207.5	-0.442
41.70	-0.082	207.5	-0.442
41.73	-0.082	207.5	-0.442
41.77	-0.082	207.5	-0.4429
41.80	-0.082	207.5	-0.4429
41.83	-0.081	207.5	-0.4429
41.87	-0.081	207.5	-0.4429
41.90	-0.081	207.5	-0.4429
41.93	-0.08	207.5	-0.4429
41.97	-0.08	207.5	-0.4429
42.00	-0.08	207.5	-0.4429
42.03	-0.08	207.5	-0.4429
42.07	-0.08	207.5	-0.4429
42.10	-0.079	207.5	-0.442

Prova triassiale ciclica SNME01-C3			
pressione di confinamento (kPa)		380	
deviatore ciclico (kPa)		80	
frequenza (hz)		0.00071429	
tempo	cella di carico	u	LVDT
(min)	kN	(kPa)	δ (mm)
42.15	-0.079	207.5	-0.442
42.18	-0.079	207.6	-0.442
42.20	-0.078	207.6	-0.442
42.23	-0.078	207.6	-0.442
42.27	-0.078	207.6	-0.442
42.30	-0.077	207.6	-0.442
42.33	-0.077	207.6	-0.442
42.37	-0.077	207.6	-0.442
42.40	-0.077	207.6	-0.442
42.43	-0.076	207.6	-0.442
42.47	-0.076	207.6	-0.4412
42.50	-0.075	207.7	-0.4412
42.53	-0.075	207.7	-0.4412
42.57	-0.075	207.7	-0.4412
42.60	-0.075	207.7	-0.4412
42.63	-0.074	207.7	-0.4412
42.67	-0.074	207.7	-0.4403
42.70	-0.073	207.8	-0.4403
42.73	-0.073	207.8	-0.4403
42.77	-0.072	207.8	-0.4403
42.80	-0.072	207.8	-0.4403
42.83	-0.072	207.8	-0.4394
42.87	-0.072	207.8	-0.4394
42.90	-0.071	207.9	-0.4394
42.93	-0.071	207.9	-0.4394
42.97	-0.07	208	-0.4385
43.00	-0.07	208	-0.4385
43.03	-0.07	208	-0.4385
43.07	-0.069	208	-0.4385
43.10	-0.068	208.1	-0.4376
43.13	-0.068	208.1	-0.4376
43.17	-0.067	208.1	-0.4376
43.20	-0.067	208.1	-0.4376
43.23	-0.066	208.2	-0.4376
43.27	-0.066	208.2	-0.4367
43.30	-0.066	208.2	-0.4367
43.33	-0.065	208.2	-0.4367
43.37	-0.065	208.3	-0.4358
43.40	-0.064	208.3	-0.4358
43.43	-0.064	208.3	-0.4349
43.47	-0.062	208.4	-0.4349
43.50	-0.062	208.4	-0.4349
43.53	-0.062	208.4	-0.4349
43.57	-0.062	208.4	-0.4341
43.62	-0.061	208.5	-0.4341
43.65	-0.061	208.5	-0.4332
43.67	-0.06	208.6	-0.4332
43.70	-0.059	208.6	-0.4323
43.73	-0.059	208.6	-0.4323
43.77	-0.058	208.7	-0.4314
43.80	-0.057	208.7	-0.4314
43.83	-0.057	208.7	-0.4314
43.87	-0.056	208.8	-0.4305
43.90	-0.056	208.8	-0.4305
43.93	-0.055	208.9	-0.4296
43.97	-0.054	208.9	-0.4287
44.00	-0.054	209	-0.4287
44.03	-0.053	209	-0.4287

Prova triassiale ciclica SNME01-C3			
pressione di confinamento (kPa)		380	
deviatore ciclico (kPa)		80	
frequenza (hz)		0.00071429	
tempo	cella di carico	u	LVDT
(min)	kN	(kPa)	δ (mm)
44.07	-0.053	209	-0.4278
44.10	-0.052	209.1	-0.4278
44.13	-0.052	209.1	-0.427
44.17	-0.05	209.2	-0.427
44.20	-0.051	209.2	-0.4261
44.23	-0.05	209.3	-0.4252
44.27	-0.048	209.3	-0.4252
44.30	-0.048	209.3	-0.4252
44.33	-0.048	209.4	-0.4243
44.37	-0.047	209.4	-0.4234
44.40	-0.046	209.5	-0.4234
44.43	-0.046	209.6	-0.4225
44.47	-0.045	209.6	-0.4216
44.50	-0.045	209.7	-0.4216
44.53	-0.045	209.7	-0.4207
44.57	-0.043	209.7	-0.4199
44.60	-0.042	209.8	-0.4199
44.63	-0.042	209.9	-0.419
44.67	-0.041	209.9	-0.4181
44.70	-0.04	210	-0.4172
44.73	-0.039	210.1	-0.4172
44.77	-0.039	210.1	-0.4163
44.80	-0.039	210.1	-0.4154
44.83	-0.038	210.2	-0.4145
44.87	-0.036	210.3	-0.4136
44.90	-0.036	210.4	-0.4128
44.93	-0.035	210.4	-0.4119
44.97	-0.034	210.5	-0.4119
45.00	-0.034	210.5	-0.411
45.05	-0.034	210.6	-0.4092
45.08	-0.032	210.7	-0.4092
45.10	-0.032	210.7	-0.4083
45.13	-0.032	210.8	-0.4065
45.17	-0.031	210.9	-0.4057
45.20	-0.029	211	-0.4048
45.23	-0.029	211	-0.4039
45.27	-0.028	211.1	-0.4021
45.30	-0.027	211.2	-0.4021
45.33	-0.027	211.2	-0.4012
45.37	-0.027	211.3	-0.3994
45.40	-0.025	211.4	-0.3986
45.43	-0.024	211.5	-0.3977
45.47	-0.023	211.5	-0.3959
45.50	-0.023	211.6	-0.395
45.53	-0.022	211.7	-0.395
45.57	-0.022	211.7	-0.3932
45.60	-0.021	211.8	-0.3906
45.63	-0.02	211.9	-0.3888
45.67	-0.019	212	-0.3861
45.70	-0.018	212.2	-0.3835
45.73	-0.017	212.3	-0.3817
45.77	-0.016	212.4	-0.3817
45.80	-0.016	212.4	-0.3799
45.83	-0.016	212.4	-0.3772
45.87	-0.015	212.6	-0.3746
45.90	-0.012	212.7	-0.3719
45.93	-0.013	212.8	-0.3701
45.97	-0.012	212.9	-0.3675

Prova triassiale ciclica SNME01-C3			
ensione di confinamento (kPa)		380	
deviatore ciclico (kPa)		80	
frequenza (hz)		0.00071429	
tempo	cella di carico	u	LVDT
(min)	kN	(kPa)	δ (mm)
46.00	-0.01	213	-0.3675
46.03	-0.01	213	-0.3639
46.07	-0.011	213.1	-0.3622
46.10	-0.009	213.2	-0.3586
46.13	-0.008	213.4	-0.3551
46.17	-0.007	213.4	-0.3515
46.20	-0.006	213.6	-0.348
46.23	-0.005	213.7	-0.348
46.27	-0.005	213.7	-0.3444
46.30	-0.005	213.8	-0.3409
46.33	-0.003	213.9	-0.3364
46.37	-0.002	214.1	-0.3311
46.40	-0.002	214.2	-0.3267
46.43	0	214.3	-0.3213
46.47	0.001	214.4	-0.3213
46.52	0.001	214.5	-0.3124
46.55	0.002	214.6	-0.3071
46.57	0.003	214.8	-0.3071
46.60	0.003	214.8	-0.3018
46.63	0.004	214.9	-0.2974
46.67	0.005	215	-0.292
46.70	0.006	215.1	-0.2876
46.73	0.006	215.2	-0.2832
46.77	0.007	215.3	-0.2778
46.80	0.009	215.5	-0.2778
46.83	0.009	215.5	-0.2707
46.87	0.009	215.6	-0.2627
46.90	0.01	215.7	-0.2539
46.93	0.012	215.8	-0.245
46.97	0.012	216	-0.2379
47.00	0.013	216.1	-0.2281
47.03	0.015	216.2	-0.2281
47.07	0.015	216.2	-0.221
47.10	0.014	216.4	-0.213
47.13	0.016	216.5	-0.2042
47.17	0.018	216.7	-0.1988
47.20	0.018	216.8	-0.1953
47.23	0.018	216.8	-0.1908
47.27	0.019	216.9	-0.1908
47.30	0.019	216.9	-0.182
47.33	0.02	217	-0.1713
47.37	0.022	217.2	-0.1598
47.40	0.022	217.4	-0.15
47.43	0.023	217.5	-0.1402
47.47	0.025	217.6	-0.1305
47.50	0.026	217.8	-0.1305
47.53	0.026	217.8	-0.1216
47.57	0.026	217.9	-0.1145
47.60	0.027	218	-0.1056
47.63	0.029	218.1	-0.0985
47.67	0.029	218.2	-0.0914
47.70	0.029	218.3	-0.0852
47.73	0.031	218.4	-0.0852
47.77	0.031	218.4	-0.079
47.80	0.031	218.5	-0.0728
47.83	0.031	218.6	-0.0675
47.87	0.034	218.8	-0.0604
47.90	0.034	218.9	-0.0541

Prova triassiale ciclica SNME01-C3			
ensione di confinamento (kPa)		380	
deviatore ciclico (kPa)		80	
frequenza (hz)		0.00071429	
tempo	cella di carico	u	LVDT
(min)	kN	(kPa)	δ (mm)
47.95	0.035	219	-0.0497
47.98	0.036	219	-0.0444
48.00	0.035	219.1	-0.0391
48.03	0.038	219.3	-0.0346
48.07	0.039	219.4	-0.0346
48.10	0.042	219.4	-0.0293
48.13	0.042	219.5	-0.024
48.17	0.04	219.5	-0.0204
48.20	0.038	219.6	-0.0186
48.23	0.042	219.7	-0.0142
48.27	0.043	219.8	-0.0107
48.30	0.044	219.9	-0.0107
48.33	0.047	219.9	-0.008
48.37	0.047	220	-0.0044
48.40	0.046	220	-0.0027
48.43	0.047	220.1	-0.0009
48.47	0.046	220.1	0.0009
48.50	0.046	220.2	0.0018
48.53	0.049	220.3	0.0018
48.57	0.051	220.3	0.0036
48.60	0.051	220.4	0.0071
48.63	0.051	220.5	0.008
48.67	0.051	220.6	0.0089
48.70	0.049	220.5	0.0098
48.73	0.052	220.7	0.0124
48.77	0.057	220.9	0.0124
48.80	0.054	220.9	0.0142
48.83	0.054	220.8	0.0142
48.87	0.053	220.9	0.0151
48.90	0.058	221.1	0.0178
48.93	0.055	221.1	0.0186
48.97	0.058	221.1	0.0195
49.00	0.06	221.2	0.0195
49.03	0.061	221.2	0.0213
49.07	0.061	221.4	0.0222
49.10	0.06	221.4	0.0231
49.13	0.058	221.4	0.0231
49.17	0.061	221.5	0.0249
49.20	0.062	221.6	0.0257
49.23	0.064	221.7	0.0257
49.27	0.064	221.7	0.0266
49.30	0.064	221.7	0.0284
49.33	0.065	221.8	0.0293
49.37	0.065	221.9	0.0302
49.42	0.066	221.9	0.0311
49.45	0.066	222	0.0328
49.47	0.07	222.2	0.0346
49.50	0.065	222.1	0.0346
49.53	0.067	222.2	0.0355
49.57	0.07	222.3	0.0355
49.60	0.071	222.3	0.0364
49.63	0.071	222.4	0.0382
49.67	0.072	222.5	0.0391
49.70	0.067	222.4	0.0391
49.73	0.074	222.6	0.0408
49.77	0.071	222.6	0.0417
49.80	0.074	222.8	0.0417
49.83	0.071	222.8	0.0426

Prova triassiale ciclica SNME01-C3			
ensione di confinamento (kPa)		380	
deviatore ciclico (kPa)		80	
frequenza (hz)		0.00071429	
tempo	cella di carico	u	LVDT
(min)	kN	(kPa)	δ (mm)
49.87	0.071	222.7	0.0426
49.90	0.076	222.9	0.0453
49.93	0.077	223	0.0462
49.97	0.073	223	0.0462
50.00	0.075	223.1	0.047
50.03	0.081	223.2	0.047
50.07	0.075	223.2	0.0488
50.10	0.075	223.2	0.0488
50.13	0.077	223.3	0.0497
50.17	0.079	223.4	0.0515
50.20	0.081	223.5	0.0524
50.23	0.078	223.5	0.0524
50.27	0.078	223.5	0.0524
50.30	0.08	223.5	0.0524
50.33	0.08	223.6	0.0533
50.37	0.081	223.6	0.0541
50.40	0.082	223.7	0.055
50.43	0.083	223.8	0.0559
50.47	0.082	223.8	0.0559
50.50	0.086	224	0.0559
50.53	0.082	224	0.0577
50.57	0.082	223.9	0.0577
50.60	0.083	224	0.0586
50.63	0.085	224.1	0.0595
50.67	0.085	224.2	0.0604
50.70	0.085	224.2	0.0604
50.73	0.086	224.3	0.0604
50.77	0.086	224.3	0.0612
50.80	0.086	224.3	0.0621
50.83	0.086	224.4	0.063
50.88	0.087	224.4	0.0639
50.90	0.087	224.5	0.0639
50.93	0.088	224.6	0.0648
50.97	0.088	224.6	0.0657
51.00	0.088	224.6	0.0666
51.03	0.089	224.8	0.0666
51.07	0.093	224.9	0.0666
51.10	0.09	224.9	0.0683
51.13	0.09	224.9	0.0683
51.17	0.089	224.9	0.0692
51.20	0.09	225	0.0692
51.23	0.091	225	0.0701
51.27	0.089	225	0.0701
51.30	0.091	225.1	0.0701
51.33	0.094	225.1	0.071
51.37	0.094	225.2	0.0719
51.40	0.092	225.2	0.0719
51.43	0.088	225.2	0.0719
51.47	0.095	225.4	0.0737
51.50	0.093	225.4	0.0737
51.53	0.092	225.4	0.0737
51.57	0.092	225.4	0.0737
51.60	0.092	225.5	0.0746
51.63	0.093	225.5	0.0754
51.67	0.094	225.6	0.0754
51.70	0.094	225.6	0.0754
51.73	0.093	225.6	0.0763
51.77	0.094	225.7	0.0763

Prova triassiale ciclica SNME01-C3			
ensione di confinamento (kPa)		380	
deviatore ciclico (kPa)		80	
frequenza (hz)		0.00071429	
tempo	cella di carico	u	LVDT
(min)	kN	(kPa)	δ (mm)
51.80	0.094	225.7	0.0763
51.83	0.094	225.7	0.0772
51.87	0.095	225.8	0.0772
51.90	0.095	225.8	0.0772
51.93	0.095	225.9	0.0781
51.97	0.095	225.9	0.0781
52.00	0.095	225.9	0.0781
52.03	0.096	225.9	0.0781
52.07	0.096	226	0.0781
52.10	0.095	226	0.079
52.13	0.092	226	0.079
52.17	0.098	226.1	0.0799
52.20	0.096	226.1	0.0799
52.23	0.095	226.2	0.0799
52.27	0.096	226.2	0.0799
52.32	0.096	226.2	0.0808
52.35	0.095	226.3	0.0808
52.37	0.096	226.3	0.0808
52.40	0.096	226.3	0.0808
52.43	0.096	226.3	0.0808
52.47	0.096	226.4	0.0817
52.50	0.096	226.4	0.0817
52.53	0.096	226.4	0.0817
52.57	0.096	226.5	0.0817
52.60	0.096	226.5	0.0817
52.63	0.096	226.5	0.0817
52.67	0.096	226.5	0.0817
52.70	0.096	226.6	0.0826
52.73	0.094	226.6	0.0826
52.77	0.097	226.7	0.0834
52.80	0.096	226.7	0.0834
52.83	0.093	226.7	0.0826
52.87	0.093	226.6	0.0826
52.90	0.099	226.8	0.0843
52.93	0.097	226.8	0.0834
52.97	0.096	226.8	0.0834
53.00	0.095	226.8	0.0834
53.03	0.095	226.8	0.0834
53.07	0.093	226.8	0.0834
53.10	0.093	226.8	0.0834
53.13	0.096	226.9	0.0834
53.17	0.096	226.9	0.0843
53.20	0.095	226.9	0.0843
53.23	0.094	226.9	0.0834
53.27	0.093	226.9	0.0834
53.30	0.092	226.9	0.0834
53.33	0.092	226.9	0.0834
53.37	0.095	227	0.0843
53.40	0.095	227	0.0843
53.43	0.093	227	0.0834
53.47	0.093	227	0.0834
53.50	0.092	227	0.0834
53.53	0.093	227	0.0834
53.57	0.093	227.1	0.0834
53.60	0.093	227.1	0.0834
53.63	0.092	227.1	0.0834
53.67	0.092	227	0.0826
53.70	0.091	227.1	0.0834

Prova triassiale ciclica SNME01-C3			
pressione di confinamento (kPa)		380	
deviatore ciclico (kPa)		80	
frequenza (hz)		0.00071429	
tempo	cella di carico	u	LVDT
(min)	kN	(kPa)	δ (mm)
53.73	0.087	227	0.0834
53.78	0.092	227.1	0.0834
53.82	0.088	227.1	0.0826
53.83	0.092	227.2	0.0826
53.87	0.088	227.2	0.0834
53.90	0.088	227.1	0.0826
53.93	0.092	227.2	0.0834
53.97	0.091	227.2	0.0834
54.00	0.089	227.2	0.0834
54.03	0.089	227.2	0.0826
54.07	0.088	227.2	0.0826
54.10	0.088	227.2	0.0826
54.13	0.088	227.2	0.0826
54.17	0.088	227.2	0.0826
54.20	0.087	227.2	0.0826
54.23	0.087	227.2	0.0817
54.27	0.086	227.2	0.0817
54.30	0.086	227.2	0.0817
54.33	0.086	227.2	0.0817
54.37	0.086	227.2	0.0817
54.40	0.085	227.2	0.0817
54.43	0.084	227.2	0.0817
54.47	0.084	227.2	0.0817
54.50	0.083	227.2	0.0808
54.53	0.083	227.2	0.0808
54.57	0.083	227.2	0.0808
54.60	0.083	227.2	0.0808
54.63	0.082	227.2	0.0808
54.67	0.081	227.2	0.0799
54.70	0.079	227.2	0.0799
54.73	0.081	227.2	0.0799
54.77	0.077	227.1	0.0799
54.80	0.082	227.1	0.079
54.83	0.082	227.2	0.0799
54.87	0.08	227.1	0.079
54.90	0.077	227.1	0.079
54.93	0.076	227.1	0.079
54.97	0.078	227.1	0.079
55.00	0.078	227.1	0.079
55.03	0.077	227.1	0.079
55.07	0.077	227.1	0.0781
55.10	0.075	227.1	0.0772
55.13	0.073	227	0.0772
55.17	0.075	227.1	0.0772
55.22	0.074	227	0.0772
55.25	0.074	227	0.0763
55.27	0.071	227	0.0763
55.30	0.07	226.9	0.0754
55.33	0.073	227	0.0754
55.37	0.07	227	0.0763
55.40	0.07	226.9	0.0754
55.43	0.072	227	0.0754
55.47	0.071	226.9	0.0754
55.50	0.068	226.8	0.0737
55.53	0.067	226.8	0.0737
55.57	0.068	226.9	0.0737
55.60	0.067	226.9	0.0737
55.63	0.067	226.8	0.0737

Prova triassiale ciclica SNME01-C3			
pressione di confinamento (kPa)		380	
deviatore ciclico (kPa)		80	
frequenza (hz)		0.00071429	
tempo	cella di carico	u	LVDT
(min)	kN	(kPa)	δ (mm)
55.67	0.063	226.7	0.0719
55.70	0.066	226.8	0.0728
55.73	0.065	226.8	0.0719
55.77	0.061	226.7	0.071
55.80	0.064	226.7	0.071
55.83	0.061	226.7	0.071
55.87	0.061	226.6	0.0701
55.90	0.063	226.7	0.0701
55.93	0.062	226.7	0.0701
55.97	0.061	226.6	0.0692
56.00	0.06	226.6	0.0683
56.03	0.058	226.5	0.0683
56.07	0.057	226.5	0.0683
56.10	0.057	226.5	0.0675
56.13	0.057	226.5	0.0675
56.17	0.056	226.4	0.0666
56.20	0.056	226.4	0.0657
56.23	0.055	226.4	0.0657
56.27	0.054	226.3	0.0657
56.30	0.053	226.3	0.0648
56.33	0.053	226.3	0.0639
56.37	0.05	226.2	0.063
56.40	0.051	226.2	0.063
56.43	0.05	226.2	0.0621
56.47	0.049	226.2	0.0612
56.50	0.051	226.2	0.0612
56.53	0.049	226.2	0.0612
56.57	0.049	226.1	0.0604
56.60	0.048	226.1	0.0595
56.63	0.046	226	0.0586
56.68	0.045	226	0.0577
56.72	0.045	225.9	0.0568
56.73	0.042	225.9	0.0559
56.77	0.044	225.9	0.0559
56.80	0.043	225.8	0.0559
56.83	0.04	225.7	0.0559
56.87	0.041	225.7	0.055
56.90	0.041	225.7	0.0541
56.93	0.04	225.7	0.0533
56.97	0.038	225.6	0.0524
57.00	0.038	225.6	0.0515
57.03	0.038	225.6	0.0497
57.07	0.036	225.5	0.0497
57.10	0.036	225.5	0.0497
57.13	0.036	225.5	0.0488
57.17	0.035	225.4	0.0479
57.20	0.032	225.3	0.0462
57.23	0.033	225.3	0.0462
57.27	0.032	225.3	0.0444
57.30	0.03	225.2	0.0444
57.33	0.03	225.2	0.0435
57.37	0.03	225.2	0.0426
57.40	0.029	225.1	0.0417
57.43	0.028	225	0.0399
57.47	0.027	225	0.0391
57.50	0.027	225	0.0382
57.53	0.025	224.9	0.0382
57.57	0.025	224.9	0.0373

Prova triassiale ciclica SNME01-C3			
pressione di confinamento (kPa)		380	
deviatore ciclico (kPa)		80	
frequenza (hz)		0.00071429	
tempo	cella di carico	u	LVDT
(min)	kN	(kPa)	δ (mm)
57.60	0.025	224.9	0.0355
57.63	0.024	224.8	0.0346
57.67	0.021	224.7	0.0328
57.70	0.023	224.7	0.0328
57.73	0.022	224.6	0.0311
57.77	0.019	224.5	0.0311
57.80	0.019	224.5	0.0293
57.83	0.019	224.5	0.0284
57.87	0.018	224.4	0.0275
57.90	0.014	224.2	0.0249
57.93	0.016	224.3	0.024
57.97	0.015	224.2	0.0231
58.00	0.014	224.1	0.0231
58.03	0.013	224.1	0.0213
58.07	0.013	224.1	0.0204
58.12	0.012	224	0.0195
58.15	0.011	224	0.0186
58.17	0.011	223.9	0.0169
58.20	0.011	223.9	0.016
58.23	0.008	223.8	0.0142
58.27	0.008	223.7	0.0133
58.30	0.007	223.7	0.0115
58.33	0.006	223.6	0.0115
58.37	0.005	223.6	0.0107
58.40	0.005	223.5	0.0089
58.43	0.005	223.5	0.0071
58.47	0.002	223.4	0.0062
58.50	0.003	223.4	0.0044
58.53	0.001	223.3	0.0027
58.57	0	223.2	0.0027
58.60	-0.001	223.2	0.0018
58.63	-0.001	223.1	0
58.67	-0.001	223.1	-0.0018
58.70	-0.003	223	-0.0036
58.73	-0.003	222.9	-0.0062
58.77	-0.004	222.8	-0.0089
58.80	-0.005	222.7	-0.0089
58.83	-0.006	222.7	-0.0115
58.87	-0.006	222.6	-0.0151
58.90	-0.007	222.5	-0.0178
58.93	-0.008	222.4	-0.0222
58.97	-0.009	222.3	-0.0266
59.00	-0.01	222.2	-0.0328
59.03	-0.011	222.1	-0.0328
59.07	-0.012	222.1	-0.0399
59.10	-0.012	222	-0.0497
59.13	-0.012	221.9	-0.0683
59.17	-0.013	221.8	-0.1039
59.20	-0.014	221.5	-0.1376
59.23	-0.015	221.3	-0.158
59.27	-0.016	221.1	-0.158
59.30	-0.017	221.1	-0.1722
59.33	-0.017	221	-0.1829
59.37	-0.018	220.7	-0.2024
59.40	-0.019	220.6	-0.2104
59.43	-0.021	220.4	-0.2184
59.47	-0.02	220.3	-0.2219
59.50	-0.021	220.2	-0.2219

Prova triassiale ciclica SNME01-C3			
pressione di confinamento (kPa)		380	
deviatore ciclico (kPa)		80	
frequenza (hz)		0.00071429	
tempo	cella di carico	u	LVDT
(min)	kN	(kPa)	δ (mm)
59.53	-0.023	220.2	-0.2272
59.58	-0.022	220	-0.2343
59.62	-0.024	219.9	-0.2343
59.63	-0.025	219.9	-0.2388
59.67	-0.025	219.8	-0.2432
59.70	-0.026	219.7	-0.2477
59.73	-0.027	219.6	-0.2512
59.77	-0.028	219.4	-0.2556
59.80	-0.028	219.4	-0.2583
59.83	-0.029	219.3	-0.2583
59.87	-0.03	219.3	-0.261
59.90	-0.03	219.1	-0.2654
59.93	-0.031	219	-0.269
59.97	-0.032	218.9	-0.2716
60.00	-0.033	218.8	-0.2752
60.03	-0.034	218.7	-0.2787
60.07	-0.035	218.6	-0.2787
60.10	-0.035	218.6	-0.2814
60.13	-0.035	218.5	-0.284
60.17	-0.036	218.4	-0.2876
60.20	-0.037	218.3	-0.2903
60.23	-0.038	218.2	-0.292
60.27	-0.038	218.2	-0.2938
60.30	-0.04	218.1	-0.2938
60.33	-0.04	218.1	-0.2965
60.37	-0.04	218	-0.2982
60.40	-0.041	217.9	-0.3
60.43	-0.042	217.8	-0.3027
60.47	-0.042	217.7	-0.3053
60.50	-0.043	217.6	-0.3098
60.53	-0.044	217.4	-0.3098
60.57	-0.045	217.4	-0.3133
60.60	-0.045	217.3	-0.316
60.63	-0.046	217.2	-0.3187
60.67	-0.046	217.1	-0.3213
60.70	-0.047	217	-0.324
60.73	-0.048	216.9	-0.3267
60.77	-0.049	216.8	-0.3267
60.80	-0.05	216.8	-0.3284
60.83	-0.05	216.7	-0.3311
60.87	-0.05	216.7	-0.3329
60.90	-0.051	216.6	-0.3346
60.93	-0.052	216.4	-0.3373
60.97	-0.052	216.4	-0.3391
61.00	-0.053	216.3	-0.3391
61.05	-0.054	216.2	-0.3426
61.08	-0.054	216.1	-0.3444
61.10	-0.055	216	-0.3444
61.13	-0.056	216	-0.3471
61.17	-0.056	215.9	-0.348
61.20	-0.056	215.9	-0.3506
61.23	-0.057	215.7	-0.3524
61.27	-0.058	215.6	-0.3533
61.30	-0.058	215.6	-0.3551
61.33	-0.059	215.5	-0.3551
61.37	-0.06	215.5	-0.3568
61.40	-0.06	215.4	-0.3586
61.43	-0.06	215.3	-0.3595

Prova triassiale ciclica SNME01-C3			
pressione di confinamento (kPa)		380	
deviatore ciclico (kPa)		80	
frequenza (hz)		0.00071429	
tempo	cella di carico	u	LVDT
(min)	kN	(kPa)	δ (mm)
61.47	-0.061	215.3	-0.3613
61.50	-0.062	215.2	-0.363
61.53	-0.062	215.1	-0.3639
61.57	-0.063	215	-0.3639
61.60	-0.064	215	-0.3657
61.63	-0.064	214.9	-0.3675
61.67	-0.064	214.9	-0.3684
61.70	-0.064	214.8	-0.3701
61.73	-0.066	214.7	-0.3719
61.77	-0.066	214.6	-0.3728
61.80	-0.067	214.5	-0.3728
61.83	-0.067	214.5	-0.3746
61.87	-0.067	214.5	-0.3755
61.90	-0.067	214.4	-0.3764
61.93	-0.069	214.3	-0.3781
61.97	-0.069	214.2	-0.379
62.00	-0.068	214.2	-0.3808
62.03	-0.069	214.1	-0.3808
62.07	-0.07	214.1	-0.3817
62.10	-0.07	214	-0.3835
62.13	-0.07	213.9	-0.3843
62.17	-0.071	213.9	-0.3852
62.20	-0.072	213.8	-0.387
62.23	-0.072	213.7	-0.3879
62.27	-0.072	213.7	-0.3879
62.30	-0.074	213.7	-0.3888
62.33	-0.074	213.6	-0.3897
62.37	-0.073	213.6	-0.3906
62.40	-0.074	213.5	-0.3914
62.43	-0.074	213.4	-0.3923
62.48	-0.074	213.4	-0.3932
62.52	-0.075	213.3	-0.3941
62.53	-0.076	213.2	-0.3959
62.57	-0.075	213.2	-0.3959
62.60	-0.076	213.1	-0.3959
62.63	-0.076	213.1	-0.3977
62.67	-0.076	213.1	-0.3986
62.70	-0.077	213	-0.3986
62.73	-0.078	212.9	-0.3994
62.77	-0.078	212.9	-0.4003
62.80	-0.078	212.8	-0.4012
62.83	-0.079	212.7	-0.4012
62.87	-0.078	212.7	-0.4021
62.90	-0.078	212.7	-0.403
62.93	-0.079	212.6	-0.4039
62.97	-0.079	212.6	-0.4048
63.00	-0.08	212.5	-0.4057
63.03	-0.08	212.5	-0.4057
63.07	-0.08	212.4	-0.4057
63.10	-0.081	212.4	-0.4065
63.13	-0.081	212.4	-0.4074
63.17	-0.081	212.3	-0.4083
63.20	-0.081	212.3	-0.4092
63.23	-0.081	212.2	-0.4092
63.27	-0.081	212.2	-0.411
63.30	-0.082	212.1	-0.411
63.33	-0.082	212.1	-0.411
63.37	-0.082	212	-0.4119

Prova triassiale ciclica SNME01-C3			
pressione di confinamento (kPa)		380	
deviatore ciclico (kPa)		80	
frequenza (hz)		0.00071429	
tempo	cella di carico	u	LVDT
(min)	kN	(kPa)	δ (mm)
63.40	-0.082	212	-0.4128
63.43	-0.082	212	-0.4128
63.47	-0.082	211.9	-0.4136
63.50	-0.083	211.9	-0.4145
63.53	-0.083	211.8	-0.4145
63.57	-0.083	211.8	-0.4145
63.60	-0.083	211.8	-0.4154
63.63	-0.083	211.8	-0.4163
63.67	-0.083	211.7	-0.4163
63.70	-0.084	211.7	-0.4172
63.73	-0.083	211.7	-0.4172
63.77	-0.083	211.6	-0.4172
63.80	-0.083	211.6	-0.4181
63.83	-0.083	211.6	-0.4181
63.87	-0.084	211.6	-0.419
63.90	-0.084	211.5	-0.419
63.95	-0.084	211.5	-0.4199
63.98	-0.084	211.5	-0.4199
64.00	-0.084	211.5	-0.4207
64.03	-0.084	211.4	-0.4207
64.07	-0.084	211.4	-0.4207
64.10	-0.084	211.4	-0.4207
64.13	-0.084	211.4	-0.4216
64.17	-0.084	211.4	-0.4216
64.20	-0.085	211.3	-0.4225
64.23	-0.084	211.3	-0.4225
64.27	-0.084	211.3	-0.4225
64.30	-0.084	211.3	-0.4234
64.33	-0.084	211.3	-0.4234
64.37	-0.084	211.3	-0.4234
64.40	-0.084	211.2	-0.4234
64.43	-0.084	211.2	-0.4234
64.47	-0.084	211.2	-0.4243
64.50	-0.084	211.2	-0.4243
64.53	-0.084	211.2	-0.4243
64.57	-0.084	211.2	-0.4243
64.60	-0.083	211.2	-0.4243
64.63	-0.083	211.2	-0.4243
64.67	-0.084	211.1	-0.4252
64.70	-0.083	211.1	-0.4252
64.73	-0.083	211.1	-0.4252
64.77	-0.083	211.1	-0.4252
64.80	-0.083	211.1	-0.4252
64.83	-0.083	211.1	-0.4252
64.87	-0.083	211.1	-0.4252
64.90	-0.083	211.1	-0.4252
64.93	-0.082	211.1	-0.4261
64.97	-0.082	211.1	-0.4261
65.00	-0.082	211.1	-0.4261
65.03	-0.082	211.1	-0.4261
65.07	-0.082	211.1	-0.4261
65.10	-0.082	211.1	-0.4261
65.13	-0.081	211.1	-0.4261
65.17	-0.081	211.1	-0.4261
65.20	-0.081	211.1	-0.4261
65.23	-0.081	211.1	-0.4261
65.27	-0.081	211.1	-0.4261
65.30	-0.079	211.1	-0.4261

Prova triassiale ciclica SNME01-C3			
pressione di confinamento (kPa)		380	
deviatore ciclico (kPa)		80	
frequenza (hz)		0.00071429	
tempo	cella di carico	u	LVDT
(min)	kN	(kPa)	δ (mm)
65.33	-0.079	211.1	-0.4252
65.38	-0.079	211.1	-0.4261
65.42	-0.08	211.1	-0.4261
65.43	-0.08	211.1	-0.4261
65.47	-0.079	211.1	-0.4252
65.50	-0.078	211.1	-0.4252
65.53	-0.079	211.1	-0.4252
65.57	-0.078	211.2	-0.4252
65.60	-0.078	211.2	-0.4252
65.63	-0.077	211.2	-0.4252
65.67	-0.077	211.2	-0.4252
65.70	-0.077	211.2	-0.4252
65.73	-0.077	211.2	-0.4252
65.77	-0.076	211.2	-0.4252
65.80	-0.076	211.2	-0.4243
65.83	-0.075	211.3	-0.4243
65.87	-0.075	211.3	-0.4243
65.90	-0.075	211.3	-0.4243
65.93	-0.075	211.3	-0.4243
65.97	-0.074	211.3	-0.4243
66.00	-0.074	211.3	-0.4234
66.03	-0.073	211.3	-0.4234
66.07	-0.073	211.4	-0.4234
66.10	-0.073	211.4	-0.4234
66.13	-0.073	211.4	-0.4234
66.17	-0.072	211.4	-0.4225
66.20	-0.071	211.4	-0.4225
66.23	-0.071	211.5	-0.4225
66.27	-0.07	211.5	-0.4225
66.30	-0.07	211.5	-0.4225
66.33	-0.07	211.5	-0.4216
66.37	-0.07	211.5	-0.4216
66.40	-0.069	211.6	-0.4216
66.43	-0.068	211.6	-0.4216
66.47	-0.068	211.6	-0.4207
66.50	-0.067	211.7	-0.4207
66.53	-0.066	211.7	-0.4207
66.57	-0.066	211.7	-0.4199
66.60	-0.066	211.7	-0.4199
66.63	-0.066	211.7	-0.4199
66.67	-0.065	211.8	-0.419
66.70	-0.064	211.8	-0.419
66.73	-0.064	211.9	-0.419
66.77	-0.063	211.9	-0.419
66.80	-0.062	211.9	-0.4181
66.85	-0.062	212	-0.4172
66.88	-0.062	212	-0.4172
66.90	-0.061	212.1	-0.4172
66.93	-0.061	212.1	-0.4172
66.97	-0.061	212.1	-0.4163
67.00	-0.06	212.2	-0.4163
67.03	-0.059	212.2	-0.4154
67.07	-0.059	212.2	-0.4154
67.10	-0.058	212.3	-0.4154
67.13	-0.057	212.3	-0.4145
67.17	-0.057	212.3	-0.4145
67.20	-0.057	212.4	-0.4136
67.23	-0.056	212.4	-0.4136

Prova triassiale ciclica SNME01-C3			
pressione di confinamento (kPa)		380	
deviatore ciclico (kPa)		80	
frequenza (hz)		0.00071429	
tempo	cella di carico	u	LVDT
(min)	kN	(kPa)	δ (mm)
67.27	-0.055	212.5	-0.4128
67.30	-0.054	212.5	-0.4128
67.33	-0.054	212.6	-0.4128
67.37	-0.053	212.6	-0.4119
67.40	-0.053	212.6	-0.4119
67.43	-0.052	212.7	-0.411
67.47	-0.052	212.8	-0.4101
67.50	-0.05	212.8	-0.4101
67.53	-0.051	212.9	-0.4092
67.57	-0.049	212.9	-0.4092
67.60	-0.049	212.9	-0.4083
67.63	-0.049	213	-0.4083
67.67	-0.048	213	-0.4074
67.70	-0.047	213.1	-0.4065
67.73	-0.046	213.1	-0.4057
67.77	-0.046	213.2	-0.4057
67.80	-0.045	213.3	-0.4057
67.83	-0.044	213.3	-0.4048
67.87	-0.044	213.3	-0.4039
67.90	-0.043	213.4	-0.403
67.93	-0.042	213.5	-0.4021
67.97	-0.041	213.5	-0.4021
68.00	-0.041	213.6	-0.4012
68.03	-0.04	213.6	-0.4012
68.07	-0.04	213.7	-0.4003
68.10	-0.04	213.7	-0.3994
68.13	-0.038	213.8	-0.3986
68.17	-0.037	213.9	-0.3986
68.20	-0.037	213.9	-0.3977
68.23	-0.036	214	-0.3968
68.27	-0.035	214.1	-0.3968
68.32	-0.035	214.1	-0.395
68.33	-0.034	214.2	-0.3941
68.37	-0.033	214.3	-0.3941
68.40	-0.032	214.4	-0.3932
68.43	-0.032	214.4	-0.3914
68.47	-0.031	214.5	-0.3906
68.50	-0.031	214.5	-0.3897
68.53	-0.03	214.6	-0.3879
68.57	-0.029	214.7	-0.387
68.60	-0.028	214.8	-0.387
68.63	-0.027	214.9	-0.3852
68.67	-0.027	214.9	-0.3843
68.70	-0.027	214.9	-0.3835
68.73	-0.024	215.1	-0.3817
68.77	-0.025	215.1	-0.3808
68.80	-0.023	215.2	-0.379
68.83	-0.022	215.3	-0.379
68.87	-0.022	215.4	-0.3772
68.90	-0.022	215.4	-0.3764
68.93	-0.021	215.5	-0.3737
68.97	-0.019	215.6	-0.371
69.00	-0.019	215.7	-0.3684
69.03	-0.019	215.8	-0.3666
69.07	-0.017	215.9	-0.3666
69.10	-0.016	216	-0.363
69.13	-0.016	216	-0.3613
69.17	-0.015	216.1	-0.3586

Prova triassiale ciclica SNME01-C3			
pressione di confinamento (kPa)		380	
deviatore ciclico (kPa)		80	
frequenza (hz)		0.00071429	
tempo	cella di carico	u	LVDT
(min)	kN	(kPa)	δ (mm)
69.20	-0.014	216.2	-0.3559
69.23	-0.013	216.4	-0.3533
69.27	-0.013	216.4	-0.3515
69.30	-0.012	216.6	-0.3515
69.33	-0.011	216.7	-0.348
69.37	-0.011	216.7	-0.3453
69.40	-0.009	216.8	-0.3426
69.43	-0.009	216.9	-0.3391
69.47	-0.009	217	-0.3364
69.50	-0.008	217.1	-0.332
69.53	-0.006	217.3	-0.332
69.57	-0.005	217.3	-0.3275
69.60	-0.005	217.3	-0.324
69.63	-0.004	217.5	-0.3196
69.67	-0.003	217.6	-0.316
69.70	-0.002	217.7	-0.3116
69.75	-0.002	217.8	-0.308
69.78	-0.001	217.9	-0.3045
69.80	0	218	-0.3
69.83	0	218.1	-0.2956
69.87	0.002	218.3	-0.2956
69.90	0.002	218.4	-0.2885
69.93	0.002	218.4	-0.2832
69.97	0.004	218.5	-0.2761
70.00	0.005	218.7	-0.2698
70.03	0.006	218.8	-0.2636
70.07	0.006	218.9	-0.2583
70.10	0.007	219	-0.2583
70.13	0.009	219.1	-0.253
70.17	0.009	219.1	-0.2468
70.20	0.009	219.2	-0.2414
70.23	0.01	219.4	-0.2334
70.27	0.011	219.5	-0.2255
70.30	0.012	219.6	-0.2166
70.33	0.015	219.8	-0.2166
70.37	0.014	219.9	-0.2086
70.40	0.014	219.9	-0.2033
70.43	0.014	220	-0.1944
70.47	0.017	220.2	-0.1846
70.50	0.017	220.3	-0.1758
70.53	0.017	220.4	-0.1695
70.57	0.019	220.6	-0.1695
70.60	0.02	220.7	-0.1624
70.63	0.02	220.7	-0.158
70.67	0.02	220.8	-0.15
70.70	0.022	220.9	-0.142
70.73	0.023	221	-0.134
70.77	0.023	221.1	-0.1278
70.80	0.024	221.3	-0.1278
70.83	0.025	221.4	-0.1207
70.87	0.025	221.4	-0.1118
70.90	0.026	221.5	-0.1039
70.93	0.028	221.7	-0.0968
70.97	0.028	221.8	-0.0905
71.00	0.029	221.9	-0.0852
71.03	0.03	222	-0.0852
71.07	0.031	222.1	-0.0799
71.10	0.031	222.1	-0.0746

Prova triassiale ciclica SNME01-C3			
ensione di confinamento (kPa)		380	
deviatore ciclico (kPa)		80	
frequenza (hz)		0.00071429	
tempo	cella di carico	u	LVDT
(min)	kN	(kPa)	δ (mm)
71.13	0.031	222.2	-0.0692
71.17	0.032	222.3	-0.0648
71.22	0.034	222.4	-0.0586
71.25	0.034	222.5	-0.0541
71.27	0.035	222.6	-0.0497
71.30	0.037	222.7	-0.0444
71.33	0.036	222.8	-0.0408
71.37	0.037	222.9	-0.0408
71.40	0.039	223	-0.0373
71.43	0.039	223	-0.0328
71.47	0.039	223.1	-0.0284
71.50	0.041	223.2	-0.0249
71.53	0.041	223.3	-0.0213
71.57	0.042	223.4	-0.0178
71.60	0.043	223.4	-0.0178
71.63	0.043	223.5	-0.0151
71.67	0.043	223.5	-0.0133
71.70	0.044	223.6	-0.0107
71.73	0.047	223.7	-0.008
71.77	0.047	223.7	-0.0071
71.80	0.047	223.8	-0.0053
71.83	0.048	223.9	-0.0053
71.87	0.049	223.9	-0.0036
71.90	0.049	223.9	-0.0018
71.93	0.049	224	-0.0009
71.97	0.051	224.1	0.0009
72.00	0.051	224.2	0.0027
72.03	0.052	224.2	0.0036
72.07	0.053	224.3	0.0036
72.10	0.054	224.4	0.0044
72.13	0.054	224.4	0.0062
72.17	0.054	224.4	0.008
72.20	0.055	224.5	0.0089
72.23	0.056	224.6	0.0098
72.27	0.057	224.7	0.0115
72.30	0.058	224.8	0.0115
72.33	0.058	224.8	0.0124
72.37	0.058	224.8	0.0133
72.40	0.058	224.9	0.0142
72.43	0.06	225	0.016
72.47	0.061	225.1	0.0169
72.50	0.061	225.1	0.0178
72.53	0.062	225.2	0.0178
72.57	0.064	225.3	0.0186
72.60	0.064	225.3	0.0204
72.65	0.064	225.4	0.0213
72.68	0.066	225.5	0.0222
72.70	0.066	225.5	0.0231
72.73	0.063	225.5	0.0231
72.77	0.065	225.6	0.024
72.80	0.067	225.7	0.0257
72.83	0.067	225.7	0.0266
72.87	0.069	225.8	0.0266
72.90	0.069	225.9	0.0284
72.93	0.069	225.9	0.0293
72.97	0.07	225.9	0.0302
73.00	0.071	226	0.0311
73.03	0.071	226.1	0.0328

Prova triassiale ciclica SNME01-C3			
pressione di confinamento (kPa)		380	
deviatore ciclico (kPa)		80	
frequenza (hz)		0.00071429	
tempo	cella di carico	u	LVDT
(min)	kN	(kPa)	δ (mm)
73.07	0.071	226.1	0.0337
73.10	0.072	226.2	0.0337
73.13	0.073	226.3	0.0346
73.17	0.073	226.3	0.0355
73.20	0.072	226.3	0.0373
73.23	0.075	226.5	0.0382
73.27	0.076	226.5	0.0391
73.30	0.075	226.5	0.0399
73.33	0.076	226.6	0.0399
73.37	0.076	226.7	0.0408
73.40	0.076	226.7	0.0417
73.43	0.077	226.8	0.0426
73.47	0.078	226.8	0.0435
73.50	0.078	226.9	0.0444
73.53	0.079	227	0.0453
73.57	0.08	227	0.0453
73.60	0.08	227.1	0.0462
73.63	0.08	227.1	0.047
73.67	0.079	227.1	0.0479
73.70	0.081	227.2	0.0488
73.73	0.082	227.3	0.0497
73.77	0.082	227.3	0.0497
73.80	0.082	227.4	0.0497
73.83	0.083	227.5	0.0506
73.87	0.083	227.5	0.0515
73.90	0.083	227.5	0.0524
73.93	0.084	227.6	0.0533
73.97	0.085	227.7	0.0541
74.00	0.085	227.7	0.055
74.03	0.086	227.8	0.055
74.07	0.086	227.8	0.0559
74.12	0.086	227.9	0.0559
74.15	0.086	227.9	0.0559
74.17	0.087	228	0.0568
74.20	0.087	228	0.0577
74.23	0.087	228.1	0.0577
74.27	0.088	228.1	0.0586
74.30	0.088	228.2	0.0595
74.33	0.089	228.2	0.0595
74.37	0.088	228.3	0.0595
74.40	0.089	228.3	0.0604
74.43	0.089	228.3	0.0612
74.47	0.09	228.4	0.0621
74.50	0.09	228.4	0.0621
74.53	0.091	228.5	0.063
74.57	0.09	228.5	0.063
74.60	0.091	228.6	0.063
74.63	0.091	228.6	0.0639
74.67	0.091	228.6	0.0639
74.70	0.091	228.7	0.0648
74.73	0.092	228.7	0.0657
74.77	0.092	228.8	0.0657
74.80	0.092	228.8	0.0666
74.83	0.093	228.9	0.0666
74.87	0.093	229	0.0666
74.90	0.093	229	0.0675
74.93	0.093	229	0.0675
74.97	0.094	229.1	0.0683

Prova triassiale ciclica SNME01-C3			
ensione di confinamento (kPa)		380	
deviatore ciclico (kPa)		80	
frequenza (hz)		0.00071429	
tempo	cella di carico	u	LVDT
(min)	kN	(kPa)	δ (mm)
75.00	0.093	229.1	0.0683
75.03	0.094	229.2	0.0692
75.07	0.094	229.2	0.0692
75.10	0.094	229.2	0.0692
75.13	0.094	229.2	0.0692
75.17	0.094	229.3	0.0701
75.20	0.094	229.3	0.0701
75.23	0.095	229.4	0.071
75.27	0.095	229.4	0.071
75.30	0.095	229.4	0.071
75.33	0.095	229.5	0.0719
75.37	0.095	229.5	0.0719
75.40	0.095	229.5	0.0719
75.43	0.095	229.6	0.0728
75.47	0.096	229.6	0.0728
75.50	0.096	229.6	0.0728
75.55	0.095	229.7	0.0737
75.58	0.096	229.7	0.0737
75.60	0.095	229.8	0.0737
75.63	0.095	229.8	0.0737
75.67	0.096	229.8	0.0737
75.70	0.096	229.8	0.0746
75.73	0.096	229.9	0.0746
75.77	0.096	229.9	0.0746
75.80	0.096	230	0.0746
75.83	0.096	230	0.0746
75.87	0.096	230	0.0746
75.90	0.095	230	0.0754
75.93	0.095	230	0.0754
75.97	0.096	230.1	0.0754
76.00	0.096	230.1	0.0754
76.03	0.097	230.2	0.0754
76.07	0.095	230.2	0.0754
76.10	0.095	230.2	0.0754
76.13	0.096	230.2	0.0754
76.17	0.096	230.2	0.0763
76.20	0.095	230.2	0.0763
76.23	0.095	230.2	0.0763
76.27	0.095	230.3	0.0763
76.30	0.095	230.3	0.0763
76.33	0.095	230.3	0.0763
76.37	0.095	230.4	0.0763
76.40	0.095	230.4	0.0763
76.43	0.095	230.4	0.0763
76.47	0.095	230.4	0.0763
76.50	0.095	230.4	0.0763
76.53	0.094	230.4	0.0763
76.57	0.094	230.4	0.0763
76.60	0.094	230.5	0.0763
76.63	0.094	230.5	0.0763
76.67	0.094	230.5	0.0763
76.70	0.094	230.5	0.0763
76.73	0.094	230.5	0.0763
76.77	0.093	230.5	0.0763
76.80	0.093	230.5	0.0763
76.83	0.093	230.6	0.0763
76.87	0.093	230.6	0.0763
76.90	0.093	230.6	0.0763

Prova triassiale ciclica SNME01-C3			
ensione di confinamento (kPa)		380	
deviatore ciclico (kPa)		80	
frequenza (hz)		0.00071429	
tempo	cella di carico	u	LVDT
(min)	kN	(kPa)	δ (mm)
76.93	0.092	230.6	0.0763
76.97	0.092	230.6	0.0763
77.02	0.091	230.6	0.0763
77.05	0.091	230.6	0.0763
77.07	0.092	230.6	0.0763
77.10	0.091	230.6	0.0763
77.13	0.091	230.6	0.0763
77.17	0.091	230.7	0.0763
77.20	0.091	230.7	0.0763
77.23	0.09	230.7	0.0754
77.27	0.089	230.7	0.0754
77.30	0.089	230.7	0.0754
77.33	0.089	230.7	0.0754
77.37	0.089	230.7	0.0754
77.40	0.088	230.7	0.0754
77.43	0.088	230.7	0.0754
77.47	0.088	230.7	0.0754
77.50	0.087	230.7	0.0754
77.53	0.087	230.7	0.0754
77.57	0.087	230.7	0.0746
77.60	0.086	230.7	0.0746
77.63	0.085	230.7	0.0746
77.67	0.085	230.7	0.0746
77.70	0.085	230.7	0.0746
77.73	0.085	230.7	0.0746
77.77	0.085	230.7	0.0746
77.80	0.084	230.7	0.0737
77.83	0.084	230.7	0.0737
77.87	0.083	230.6	0.0737
77.90	0.083	230.6	0.0737
77.93	0.083	230.7	0.0737
77.97	0.082	230.7	0.0737
78.00	0.082	230.7	0.0737
78.03	0.081	230.6	0.0728
78.07	0.08	230.6	0.0728
78.10	0.08	230.6	0.0728
78.13	0.08	230.6	0.0719
78.17	0.079	230.6	0.0719
78.20	0.079	230.6	0.0719
78.23	0.077	230.6	0.0719
78.27	0.078	230.6	0.0719
78.30	0.078	230.6	0.0719
78.33	0.076	230.5	0.071
78.37	0.076	230.5	0.071
78.40	0.076	230.5	0.071
78.43	0.075	230.5	0.0701
78.48	0.074	230.5	0.0701
78.52	0.074	230.5	0.0701
78.55	0.074	230.5	0.0692
78.57	0.073	230.4	0.0692
78.60	0.073	230.4	0.0692
78.63	0.071	230.4	0.0692
78.67	0.071	230.4	0.0683
78.70	0.071	230.4	0.0683
78.73	0.071	230.4	0.0683
78.77	0.07	230.3	0.0675
78.80	0.069	230.3	0.0675
78.83	0.068	230.3	0.0666

Prova triassiale ciclica SNME01-C3			
pressione di confinamento (kPa)		380	
deviatore ciclico (kPa)		80	
frequenza (hz)		0.00071429	
tempo	cella di carico	u	LVDT
(min)	kN	(kPa)	δ (mm)
78.87	0.068	230.3	0.0666
78.90	0.067	230.2	0.0666
78.93	0.067	230.2	0.0657
78.97	0.066	230.2	0.0657
79.00	0.066	230.2	0.0648
79.03	0.065	230.2	0.0648
79.07	0.064	230.1	0.0639
79.10	0.064	230.1	0.0639
79.13	0.063	230.1	0.0639
79.17	0.063	230.1	0.063
79.20	0.062	230.1	0.063
79.23	0.061	230	0.0621
79.27	0.06	230	0.0621
79.30	0.06	230	0.0612
79.33	0.059	229.9	0.0612
79.37	0.058	229.9	0.0612
79.40	0.058	229.9	0.0604
79.43	0.057	229.8	0.0595
79.47	0.057	229.8	0.0595
79.50	0.056	229.8	0.0586
79.53	0.055	229.7	0.0577
79.57	0.054	229.7	0.0577
79.60	0.054	229.7	0.0577
79.63	0.054	229.7	0.0568
79.67	0.053	229.6	0.0559
79.70	0.052	229.6	0.0559
79.73	0.051	229.5	0.055
79.77	0.05	229.5	0.055
79.80	0.05	229.5	0.055
79.83	0.049	229.4	0.0541
79.87	0.049	229.4	0.0533
79.92	0.047	229.4	0.0524
79.95	0.047	229.3	0.0524
79.97	0.047	229.3	0.0515
80.00	0.046	229.3	0.0506
80.03	0.044	229.2	0.0497
80.07	0.044	229.2	0.0488
80.10	0.043	229.1	0.0479
80.13	0.042	229.1	0.0479
80.17	0.041	229	0.047
80.20	0.041	229	0.0462
80.23	0.041	229	0.0462
80.27	0.04	228.9	0.0444
80.30	0.038	228.8	0.0435
80.33	0.038	228.8	0.0435
80.37	0.037	228.8	0.0435
80.40	0.036	228.7	0.0417
80.43	0.036	228.7	0.0408
80.47	0.035	228.7	0.0399
80.50	0.034	228.6	0.0391
80.53	0.033	228.6	0.0382
80.57	0.033	228.5	0.0373
80.60	0.032	228.5	0.0373
80.63	0.031	228.4	0.0364
80.67	0.031	228.4	0.0355
80.70	0.03	228.3	0.0346
80.73	0.029	228.3	0.0328
80.77	0.028	228.2	0.032

Prova triassiale ciclica SNME01-C3			
pressione di confinamento (kPa)		380	
deviatore ciclico (kPa)		80	
frequenza (hz)		0.00071429	
tempo	cella di carico	u	LVDT
(min)	kN	(kPa)	δ (mm)
80.80	0.027	228.2	0.0311
80.83	0.026	228.1	0.0311
80.87	0.025	228	0.0302
80.90	0.025	228	0.0284
80.93	0.025	228	0.0275
80.97	0.023	227.9	0.0266
81.00	0.023	227.9	0.0257
81.03	0.022	227.8	0.024
81.07	0.02	227.7	0.024
81.10	0.02	227.7	0.0231
81.13	0.02	227.7	0.0213
81.17	0.019	227.6	0.0204
81.20	0.018	227.6	0.0195
81.23	0.016	227.5	0.0178
81.27	0.016	227.4	0.0169
81.30	0.015	227.4	0.0169
81.33	0.014	227.3	0.016
81.38	0.014	227.3	0.0133
81.42	0.012	227.2	0.0133
81.43	0.012	227.1	0.0124
81.47	0.012	227.1	0.0107
81.50	0.011	227.1	0.0098
81.53	0.009	227	0.008
81.57	0.009	226.9	0.0071
81.60	0.008	226.9	0.0053
81.63	0.007	226.8	0.0053
81.67	0.006	226.7	0.0044
81.70	0.006	226.7	0.0027
81.73	0.005	226.6	0.0018
81.77	0.004	226.6	0
81.80	0.003	226.5	-0.0009
81.83	0.002	226.5	-0.0027
81.87	0.001	226.4	-0.0027
81.90	0.001	226.3	-0.0036
81.93	0.001	226.3	-0.0053
81.97	-0.001	226.2	-0.0071
82.00	-0.002	226.1	-0.008
82.03	-0.003	226.1	-0.0098
82.07	-0.003	226	-0.0115
82.10	-0.004	225.9	-0.0115
82.13	-0.006	225.8	-0.0133
82.17	-0.006	225.8	-0.016
82.20	-0.006	225.7	-0.0178
82.23	-0.007	225.6	-0.0204
82.27	-0.008	225.6	-0.0231
82.30	-0.009	225.5	-0.0257
82.33	-0.01	225.3	-0.0257
82.37	-0.012	225.2	-0.0293
82.40	-0.012	225.2	-0.032
82.43	-0.012	225.2	-0.0346
82.47	-0.012	225.1	-0.0382
82.50	-0.014	225	-0.0426
82.53	-0.015	224.9	-0.047
82.57	-0.015	224.8	-0.047
82.60	-0.017	224.6	-0.0533
82.63	-0.017	224.6	-0.0648
82.67	-0.017	224.5	-0.0826
82.70	-0.017	224.3	-0.1163

Prova triassiale ciclica SNME01-C3			
pressione di confinamento (kPa)		380	
deviatore ciclico (kPa)		80	
frequenza (hz)		0.00071429	
tempo	cella di carico	u	LVDT
(min)	kN	(kPa)	δ (mm)
82.73	-0.018	224	-0.1633
82.77	-0.02	223.8	-0.1766
82.82	-0.021	223.5	-0.1988
82.85	-0.022	223.4	-0.2077
82.87	-0.022	223.3	-0.213
82.90	-0.023	223.1	-0.213
82.93	-0.025	223	-0.2184
82.97	-0.025	223	-0.2237
83.00	-0.025	222.9	-0.2272
83.03	-0.026	222.8	-0.2299
83.07	-0.026	222.7	-0.2343
83.10	-0.028	222.6	-0.2379
83.13	-0.028	222.5	-0.2414
83.17	-0.029	222.4	-0.245
83.20	-0.031	222.2	-0.245
83.23	-0.032	222.2	-0.2485
83.27	-0.031	222.1	-0.2521
83.30	-0.031	222	-0.2556
83.33	-0.032	221.9	-0.2592
83.37	-0.033	221.8	-0.2619
83.40	-0.034	221.7	-0.2654
83.43	-0.035	221.6	-0.2681
83.47	-0.036	221.5	-0.2707
83.50	-0.036	221.4	-0.2743
83.53	-0.038	221.2	-0.2743
83.57	-0.038	221.2	-0.2778
83.60	-0.038	221.1	-0.2805
83.63	-0.038	221	-0.2823
83.67	-0.041	220.9	-0.2858
83.70	-0.04	220.8	-0.2867
83.73	-0.041	220.8	-0.2894
83.77	-0.043	220.6	-0.2894
83.80	-0.043	220.5	-0.292
83.83	-0.043	220.5	-0.2938
83.87	-0.044	220.4	-0.2965
83.90	-0.045	220.3	-0.3
83.93	-0.045	220.2	-0.3027
83.97	-0.046	220	-0.3062
84.00	-0.047	219.9	-0.308
84.03	-0.047	219.8	-0.308
84.07	-0.048	219.8	-0.3107
84.10	-0.048	219.7	-0.3124
84.13	-0.049	219.6	-0.3151
84.17	-0.05	219.5	-0.3169
84.20	-0.05	219.5	-0.3187
84.23	-0.051	219.4	-0.3213
84.28	-0.052	219.3	-0.3231
84.32	-0.053	219.2	-0.3249
84.35	-0.053	219.1	-0.3267
84.38	-0.054	219	-0.3267
84.40	-0.055	218.9	-0.3284
84.43	-0.055	218.9	-0.3302
84.47	-0.055	218.8	-0.332
84.50	-0.055	218.7	-0.3338
84.53	-0.057	218.6	-0.3364
84.57	-0.057	218.6	-0.3373
84.60	-0.057	218.4	-0.3391
84.63	-0.059	218.4	-0.3391

Prova triassiale ciclica SNME01-C3			
pressione di confinamento (kPa)		380	
deviatore ciclico (kPa)		80	
frequenza (hz)		0.00071429	
tempo	cella di carico	u	LVDT
(min)	kN	(kPa)	δ (mm)
84.67	-0.059	218.4	-0.3409
84.70	-0.059	218.3	-0.3426
84.73	-0.06	218.2	-0.3444
84.77	-0.06	218.1	-0.3462
84.80	-0.062	218	-0.348
84.83	-0.062	217.9	-0.3488
84.87	-0.062	217.8	-0.3488
84.90	-0.062	217.8	-0.3506
84.93	-0.062	217.8	-0.3515
84.97	-0.063	217.7	-0.3533
85.00	-0.064	217.6	-0.3542
85.03	-0.065	217.5	-0.3559
85.07	-0.065	217.4	-0.3568
85.10	-0.066	217.3	-0.3568
85.13	-0.066	217.3	-0.3586
85.17	-0.066	217.3	-0.3595
85.20	-0.067	217.2	-0.3613
85.23	-0.068	217.1	-0.3622
85.27	-0.068	217	-0.363
85.30	-0.068	217	-0.3639
85.33	-0.069	216.9	-0.3657
85.37	-0.07	216.8	-0.3657
85.40	-0.07	216.8	-0.3666
85.43	-0.07	216.8	-0.3675
85.47	-0.071	216.7	-0.3684
85.50	-0.071	216.6	-0.3701
85.53	-0.072	216.6	-0.371
85.57	-0.072	216.5	-0.3719
85.60	-0.072	216.4	-0.3719
85.63	-0.073	216.4	-0.3728
85.67	-0.074	216.4	-0.3737
85.70	-0.074	216.2	-0.3746
85.75	-0.074	216.2	-0.3755
85.78	-0.075	216.2	-0.3764
85.82	-0.075	216.1	-0.3772
85.85	-0.075	216	-0.3781
85.87	-0.075	216	-0.379
85.90	-0.076	215.9	-0.3799
85.93	-0.076	215.8	-0.3808
85.97	-0.076	215.8	-0.3817
86.00	-0.077	215.7	-0.3817
86.03	-0.077	215.7	-0.3826
86.07	-0.077	215.6	-0.3835
86.10	-0.078	215.6	-0.3843
86.13	-0.078	215.5	-0.3852
86.17	-0.078	215.5	-0.3861
86.20	-0.078	215.4	-0.387
86.23	-0.079	215.4	-0.387
86.27	-0.08	215.3	-0.387
86.30	-0.08	215.3	-0.3879
86.33	-0.079	215.3	-0.3888
86.37	-0.08	215.2	-0.3897
86.40	-0.08	215.2	-0.3897
86.43	-0.08	215.1	-0.3906
86.47	-0.08	215	-0.3914
86.50	-0.081	215	-0.3914
86.53	-0.081	215	-0.3923
86.57	-0.081	214.9	-0.3923

Prova triassiale ciclica SNME01-C3			
pressione di confinamento (kPa)		380	
deviatore ciclico (kPa)		80	
frequenza (hz)		0.00071429	
tempo	cella di carico	u	LVDT
(min)	kN	(kPa)	δ (mm)
86.60	-0.081	214.9	-0.3932
86.63	-0.082	214.9	-0.3941
86.67	-0.083	214.8	-0.395
86.70	-0.082	214.8	-0.395
86.73	-0.081	214.8	-0.395
86.77	-0.082	214.7	-0.395
86.80	-0.082	214.7	-0.3959
86.83	-0.082	214.7	-0.3968
86.87	-0.082	214.6	-0.3968
86.90	-0.083	214.6	-0.3977
86.93	-0.083	214.5	-0.3986
86.97	-0.083	214.5	-0.3986
87.00	-0.083	214.5	-0.3986
87.03	-0.084	214.5	-0.3986
87.07	-0.084	214.4	-0.3986
87.10	-0.083	214.4	-0.3994
87.13	-0.083	214.3	-0.3994
87.18	-0.084	214.3	-0.4003
87.22	-0.084	214.3	-0.4003
87.23	-0.084	214.3	-0.4003
87.27	-0.084	214.2	-0.4012
87.30	-0.084	214.2	-0.4012
87.33	-0.083	214.2	-0.4012
87.37	-0.084	214.2	-0.4021
87.40	-0.084	214.1	-0.4021
87.43	-0.084	214.1	-0.4021
87.47	-0.084	214.1	-0.403
87.50	-0.084	214.1	-0.403
87.53	-0.084	214	-0.403
87.57	-0.084	214	-0.403
87.60	-0.084	214	-0.4039
87.63	-0.084	214	-0.4039
87.67	-0.084	214	-0.4039
87.70	-0.084	214	-0.4039
87.73	-0.084	213.9	-0.4048
87.77	-0.084	213.9	-0.4048
87.80	-0.084	213.9	-0.4048
87.83	-0.084	213.9	-0.4048
87.87	-0.084	213.9	-0.4048
87.90	-0.084	213.9	-0.4048
87.93	-0.084	213.9	-0.4057
87.97	-0.084	213.9	-0.4057
88.00	-0.083	213.8	-0.4057
88.03	-0.083	213.8	-0.4057
88.07	-0.083	213.8	-0.4057
88.10	-0.083	213.8	-0.4065
88.13	-0.083	213.8	-0.4065
88.17	-0.083	213.8	-0.4065
88.20	-0.083	213.8	-0.4065
88.23	-0.082	213.8	-0.4065
88.27	-0.082	213.8	-0.4065
88.30	-0.082	213.8	-0.4065
88.33	-0.082	213.8	-0.4065
88.37	-0.082	213.8	-0.4065
88.40	-0.082	213.8	-0.4065
88.43	-0.082	213.8	-0.4065
88.47	-0.081	213.8	-0.4065
88.50	-0.081	213.8	-0.4065

Prova triassiale ciclica SNME01-C3			
pressione di confinamento (kPa)		380	
deviatore ciclico (kPa)		80	
frequenza (hz)		0.00071429	
tempo	cella di carico	u	LVDT
(min)	kN	(kPa)	δ (mm)
88.53	-0.081	213.8	-0.4065
88.57	-0.081	213.8	-0.4065
88.60	-0.081	213.8	-0.4065
88.65	-0.08	213.8	-0.4065
88.68	-0.08	213.8	-0.4065
88.70	-0.08	213.8	-0.4065
88.73	-0.08	213.8	-0.4065
88.77	-0.079	213.8	-0.4065
88.80	-0.079	213.8	-0.4057
88.83	-0.078	213.8	-0.4057
88.87	-0.078	213.8	-0.4057
88.90	-0.078	213.8	-0.4057
88.93	-0.078	213.8	-0.4057
88.97	-0.078	213.9	-0.4057
89.00	-0.077	213.9	-0.4057
89.03	-0.077	213.9	-0.4057
89.07	-0.076	213.9	-0.4057
89.10	-0.076	213.9	-0.4057
89.13	-0.076	213.9	-0.4057
89.17	-0.076	213.9	-0.4048
89.20	-0.075	213.9	-0.4048
89.23	-0.075	214	-0.4048
89.27	-0.075	214	-0.4039
89.30	-0.074	214	-0.4039
89.33	-0.074	214	-0.4039
89.37	-0.074	214	-0.4039
89.40	-0.073	214	-0.4039
89.43	-0.073	214	-0.4039
89.47	-0.072	214.1	-0.4039
89.50	-0.072	214.1	-0.403
89.53	-0.071	214.1	-0.403
89.57	-0.071	214.1	-0.403
89.60	-0.071	214.1	-0.403
89.63	-0.07	214.2	-0.4021
89.67	-0.07	214.2	-0.4021
89.70	-0.069	214.2	-0.4021
89.73	-0.068	214.3	-0.4021
89.77	-0.068	214.3	-0.4021
89.80	-0.068	214.3	-0.4012
89.83	-0.068	214.3	-0.4012
89.87	-0.067	214.3	-0.4012
89.90	-0.067	214.4	-0.4003
89.93	-0.066	214.4	-0.4003
89.97	-0.065	214.5	-0.3994
90.00	-0.065	214.5	-0.3994
90.03	-0.064	214.5	-0.3994
90.08	-0.064	214.5	-0.3994
90.12	-0.064	214.6	-0.3994
90.13	-0.062	214.6	-0.3986
90.17	-0.062	214.6	-0.3986
90.20	-0.062	214.7	-0.3986
90.23	-0.062	214.7	-0.3986
90.27	-0.061	214.7	-0.3986
90.30	-0.061	214.8	-0.3977
90.33	-0.06	214.8	-0.3977
90.37	-0.059	214.8	-0.3968
90.40	-0.059	214.9	-0.3968
90.43	-0.058	214.9	-0.3968

Prova triassiale ciclica SNME01-C3			
pressione di confinamento (kPa)		380	
deviatore ciclico (kPa)		80	
frequenza (hz)		0.00071429	
tempo	cella di carico	u	LVDT
(min)	kN	(kPa)	δ (mm)
90.47	-0.057	215	-0.3959
90.50	-0.057	215	-0.3959
90.53	-0.056	215	-0.395
90.57	-0.055	215.1	-0.395
90.60	-0.054	215.2	-0.395
90.63	-0.054	215.2	-0.3941
90.67	-0.055	215.2	-0.3932
90.70	-0.053	215.2	-0.3932
90.73	-0.053	215.3	-0.3923
90.77	-0.052	215.3	-0.3923
90.80	-0.051	215.4	-0.3923
90.83	-0.05	215.4	-0.3914
90.87	-0.05	215.5	-0.3906
90.90	-0.05	215.5	-0.3897
90.93	-0.049	215.6	-0.3897
90.97	-0.048	215.6	-0.3888
91.00	-0.048	215.7	-0.3888
91.03	-0.047	215.7	-0.3888
91.07	-0.046	215.7	-0.3879
91.10	-0.046	215.8	-0.387
91.13	-0.045	215.9	-0.3861
91.17	-0.044	215.9	-0.3861
91.20	-0.044	216	-0.3852
91.23	-0.043	216	-0.3843
91.27	-0.042	216.1	-0.3843
91.30	-0.041	216.1	-0.3835
91.33	-0.041	216.2	-0.3826
91.37	-0.042	216.2	-0.3817
91.40	-0.039	216.4	-0.3808
91.43	-0.039	216.4	-0.3799
91.47	-0.038	216.5	-0.379
91.50	-0.037	216.6	-0.379
91.55	-0.037	216.6	-0.3781
91.58	-0.036	216.7	-0.3772
91.60	-0.035	216.8	-0.3772
91.63	-0.034	216.8	-0.3764
91.67	-0.034	216.8	-0.3746
91.70	-0.034	216.9	-0.3737
91.73	-0.033	217	-0.3728
91.77	-0.031	217.1	-0.371
91.80	-0.031	217.1	-0.3701
91.83	-0.03	217.2	-0.3701
91.87	-0.029	217.3	-0.3693
91.90	-0.029	217.3	-0.3675
91.93	-0.029	217.4	-0.3666
91.97	-0.027	217.5	-0.3648
92.00	-0.026	217.5	-0.3639
92.03	-0.026	217.6	-0.3622
92.07	-0.025	217.7	-0.3622
92.10	-0.024	217.8	-0.3604
92.13	-0.024	217.8	-0.3586
92.17	-0.022	218	-0.3559
92.20	-0.022	218	-0.3542
92.23	-0.021	218.2	-0.3515
92.27	-0.021	218.2	-0.3497
92.30	-0.02	218.3	-0.3497
92.33	-0.019	218.4	-0.3471
92.37	-0.019	218.4	-0.3453

Prova triassiale ciclica SNME01-C3			
pressione di confinamento (kPa)		380	
deviatore ciclico (kPa)		80	
frequenza (hz)		0.00071429	
tempo	cella di carico	u	LVDT
(min)	kN	(kPa)	δ (mm)
92.40	-0.018	218.6	-0.3426
92.43	-0.016	218.7	-0.34
92.47	-0.016	218.8	-0.3373
92.50	-0.015	218.9	-0.3346
92.53	-0.014	219	-0.3346
92.57	-0.013	219.1	-0.3329
92.60	-0.013	219.1	-0.3302
92.63	-0.012	219.2	-0.3275
92.67	-0.012	219.3	-0.3249
92.70	-0.01	219.4	-0.3213
92.73	-0.01	219.5	-0.3187
92.77	-0.008	219.6	-0.3187
92.80	-0.008	219.7	-0.3142
92.83	-0.008	219.7	-0.3116
92.87	-0.007	219.8	-0.3089
92.90	-0.006	220	-0.3045
92.93	-0.005	220.1	-0.3009
92.98	-0.004	220.2	-0.2974
93.02	-0.004	220.3	-0.2938
93.03	-0.002	220.4	-0.2885
93.07	-0.001	220.6	-0.2832
93.10	0	220.7	-0.2832
93.13	0.001	220.8	-0.2796
93.17	0.001	220.8	-0.2752
93.20	0	220.9	-0.2716
93.23	0.002	221.1	-0.2645
93.27	0.004	221.2	-0.2583
93.30	0.004	221.3	-0.253
93.33	0.005	221.4	-0.253
93.37	0.006	221.6	-0.2468
93.40	0.006	221.6	-0.2406
93.43	0.007	221.7	-0.2343
93.47	0.009	221.9	-0.2272
93.50	0.009	222	-0.2228
93.53	0.01	222	-0.2166
93.57	0.011	222.2	-0.2166
93.60	0.012	222.3	-0.2104
93.63	0.012	222.3	-0.2033
93.67	0.012	222.4	-0.1971
93.70	0.014	222.6	-0.1908
93.73	0.015	222.7	-0.1837
93.77	0.015	222.8	-0.1775
93.80	0.017	223	-0.1775
93.83	0.017	223.1	-0.1713
93.87	0.017	223.1	-0.1678
93.90	0.018	223.2	-0.1616
93.93	0.019	223.3	-0.1527
93.97	0.02	223.4	-0.1456
94.00	0.021	223.6	-0.1385
94.03	0.022	223.7	-0.1385
94.07	0.023	223.8	-0.1323
94.10	0.023	223.8	-0.126
94.13	0.023	223.9	-0.1207
94.17	0.025	224	-0.1154
94.20	0.026	224.1	-0.1101
94.23	0.026	224.2	-0.1047
94.27	0.028	224.4	-0.1047
94.30	0.029	224.5	-0.0994

Prova triassiale ciclica SNME01-C3			
pressione di confinamento (kPa)		380	
deviatore ciclico (kPa)		80	
frequenza (hz)		0.00071429	
tempo	cella di carico	u	LVDT
(min)	kN	(kPa)	δ (mm)
94.33	0.029	224.5	-0.095
94.37	0.029	224.5	-0.0897
94.40	0.031	224.7	-0.0843
94.45	0.031	224.8	-0.0799
94.48	0.031	224.9	-0.0754
94.50	0.032	225	-0.071
94.53	0.035	225.1	-0.0657
94.57	0.034	225.1	-0.0621
94.60	0.035	225.2	-0.0621
94.63	0.037	225.4	-0.0568
94.67	0.037	225.4	-0.0515
94.70	0.037	225.4	-0.047
94.73	0.038	225.6	-0.0435
94.77	0.038	225.6	-0.0399
94.80	0.039	225.7	-0.0355
94.83	0.041	225.8	-0.0355
94.87	0.042	225.9	-0.032
94.90	0.042	225.9	-0.0293
94.93	0.043	225.9	-0.0266
94.97	0.043	226	-0.0249
95.00	0.045	226.1	-0.0231
95.03	0.044	226.1	-0.0213
95.07	0.046	226.2	-0.0213
95.10	0.047	226.3	-0.0186
95.13	0.047	226.3	-0.0178
95.17	0.047	226.3	-0.016
95.20	0.048	226.4	-0.0142
95.23	0.05	226.5	-0.0124
95.27	0.05	226.6	-0.0115
95.30	0.051	226.7	-0.0115
95.33	0.052	226.7	-0.0098
95.37	0.052	226.7	-0.0089
95.40	0.052	226.8	-0.0071
95.43	0.053	226.9	-0.0062
95.47	0.055	226.9	-0.0044
95.50	0.054	227	-0.0036
95.53	0.056	227.1	-0.0036
95.57	0.056	227.1	-0.0027
95.60	0.056	227.1	-0.0018
95.63	0.058	227.2	0
95.67	0.058	227.3	0.0009
95.70	0.059	227.4	0.0027
95.73	0.059	227.4	0.0036
95.77	0.061	227.5	0.0036
95.80	0.061	227.6	0.0044
95.83	0.061	227.6	0.0053
95.87	0.062	227.7	0.0062
95.92	0.063	227.8	0.008
95.93	0.063	227.8	0.0089
95.97	0.063	227.9	0.0098
96.00	0.065	228	0.0107
96.03	0.065	228	0.0124
96.07	0.066	228.1	0.0133
96.10	0.067	228.2	0.0133
96.13	0.067	228.2	0.0142
96.17	0.067	228.2	0.0151
96.20	0.067	228.3	0.016
96.23	0.069	228.4	0.0169

Prova triassiale ciclica SNME01-C3			
pressione di confinamento (kPa)		380	
deviatore ciclico (kPa)		80	
frequenza (hz)		0.00071429	
tempo	cella di carico	u	LVDT
(min)	kN	(kPa)	δ (mm)
96.27	0.069	228.4	0.0178
96.30	0.071	228.5	0.0195
96.33	0.071	228.6	0.0195
96.37	0.072	228.7	0.0204
96.40	0.072	228.7	0.0213
96.43	0.072	228.7	0.0222
96.47	0.073	228.8	0.0231
96.50	0.072	228.8	0.024
96.53	0.073	228.9	0.0249
96.57	0.074	229	0.0249
96.60	0.075	229.1	0.0257
96.63	0.075	229.1	0.0266
96.67	0.075	229.1	0.0275
96.70	0.076	229.2	0.0284
96.73	0.078	229.3	0.0302
96.77	0.079	229.4	0.0311
96.80	0.077	229.4	0.0311
96.83	0.077	229.4	0.0311
96.87	0.077	229.4	0.032
96.90	0.079	229.5	0.0328
96.93	0.08	229.6	0.0337
96.97	0.081	229.7	0.0346
97.00	0.08	229.7	0.0355
97.03	0.081	229.8	0.0355
97.07	0.082	229.9	0.0364
97.10	0.082	229.9	0.0373
97.13	0.082	229.9	0.0382
97.17	0.083	230	0.0391
97.20	0.083	230.1	0.0399
97.23	0.084	230.1	0.0408
97.27	0.084	230.2	0.0408
97.30	0.086	230.3	0.0417
97.35	0.086	230.4	0.0435
97.38	0.087	230.4	0.0435
97.40	0.084	230.4	0.0435
97.43	0.084	230.4	0.0435
97.47	0.086	230.5	0.0453
97.50	0.089	230.6	0.0462
97.53	0.088	230.6	0.047
97.57	0.088	230.7	0.047
97.60	0.088	230.7	0.047
97.63	0.088	230.8	0.0479
97.67	0.088	230.8	0.0479
97.70	0.089	230.8	0.0488
97.73	0.089	230.9	0.0488
97.77	0.089	230.9	0.0497
97.80	0.09	231	0.0506
97.83	0.09	231.1	0.0506
97.87	0.09	231.1	0.0506
97.90	0.09	231.1	0.0515
97.93	0.091	231.2	0.0524
97.97	0.091	231.2	0.0524
98.00	0.091	231.2	0.0524
98.03	0.091	231.3	0.0533
98.07	0.092	231.4	0.0533
98.10	0.093	231.4	0.0541
98.13	0.093	231.4	0.0541
98.17	0.092	231.5	0.055

Prova triassiale ciclica SNME01-C3			
pressione di confinamento (kPa)		380	
deviatore ciclico (kPa)		80	
frequenza (hz)		0.00071429	
tempo	cella di carico	u	LVDT
(min)	kN	(kPa)	δ (mm)
98.20	0.093	231.5	0.055
98.23	0.093	231.6	0.0559
98.27	0.093	231.6	0.0559
98.30	0.093	231.6	0.0559
98.33	0.094	231.7	0.0559
98.37	0.094	231.7	0.0559
98.40	0.094	231.7	0.0568
98.43	0.094	231.8	0.0568
98.47	0.092	231.8	0.0568
98.50	0.096	231.9	0.0577
98.53	0.094	231.9	0.0577
98.57	0.097	232	0.0577
98.60	0.097	232	0.0586
98.63	0.092	231.9	0.0577
98.67	0.096	232.1	0.0595
98.70	0.094	232	0.0586
98.73	0.095	232.1	0.0595
98.77	0.098	232.2	0.0595
98.82	0.095	232.2	0.0604
98.85	0.095	232.2	0.0604
98.87	0.097	232.3	0.0604
98.90	0.097	232.4	0.0612
98.93	0.097	232.4	0.0612
98.97	0.096	232.4	0.0612
99.00	0.095	232.4	0.0612
99.03	0.093	232.3	0.0612
99.07	0.098	232.5	0.063
99.10	0.098	232.5	0.063
99.13	0.097	232.5	0.063
99.17	0.097	232.5	0.063
99.20	0.096	232.5	0.063
99.23	0.095	232.6	0.063
99.27	0.095	232.6	0.063
99.30	0.097	232.6	0.063
99.33	0.095	232.6	0.063
99.37	0.094	232.6	0.063
99.40	0.094	232.6	0.063
99.43	0.097	232.7	0.0639
99.47	0.098	232.8	0.0639
99.50	0.096	232.8	0.0639
99.53	0.095	232.8	0.0639
99.57	0.095	232.8	0.0639
99.60	0.095	232.8	0.0639
99.63	0.095	232.8	0.0639
99.67	0.095	232.9	0.0639
99.70	0.095	232.9	0.0639
99.73	0.092	232.8	0.0639
99.77	0.097	233	0.0648
99.80	0.097	233	0.0648
99.83	0.091	232.9	0.0648
99.87	0.091	232.9	0.0639
99.90	0.097	233	0.0648
99.93	0.094	233	0.0648
99.97	0.096	233	0.0648
100.00	0.094	233	0.0648
100.03	0.093	233	0.0648
100.07	0.091	233	0.0639
100.10	0.091	233	0.0639

Prova triassiale ciclica SNME01-C3			
pressione di confinamento (kPa)		380	
deviatore ciclico (kPa)		80	
frequenza (hz)		0.00071429	
tempo	cella di carico	u	LVDT
(min)	kN	(kPa)	δ (mm)
100.13	0.095	233.1	0.0648
100.17	0.095	233.2	0.0639
100.20	0.093	233.1	0.0639
100.25	0.093	233.1	0.0639
100.28	0.092	233.1	0.0639
100.30	0.092	233.1	0.0639
100.33	0.09	233.1	0.0639
100.37	0.093	233.2	0.0639
100.40	0.092	233.2	0.0639
100.43	0.092	233.2	0.0639
100.47	0.091	233.2	0.0639
100.50	0.09	233.2	0.0639
100.53	0.088	233.1	0.063
100.57	0.089	233.2	0.063
100.60	0.09	233.2	0.063
100.63	0.092	233.3	0.0639
100.67	0.092	233.3	0.0639
100.70	0.09	233.2	0.063
100.73	0.088	233.2	0.063
100.77	0.088	233.2	0.063
100.80	0.087	233.2	0.063
100.83	0.087	233.2	0.063
100.87	0.085	233.2	0.063
100.90	0.085	233.2	0.063
100.93	0.088	233.2	0.063
100.97	0.088	233.3	0.063
101.00	0.084	233.2	0.0621
101.03	0.084	233.2	0.0621
101.07	0.084	233.2	0.0621
101.10	0.084	233.2	0.0621
101.13	0.084	233.2	0.0621
101.17	0.084	233.2	0.0621
101.20	0.083	233.2	0.0612
101.23	0.082	233.2	0.0612
101.27	0.083	233.2	0.0612
101.30	0.082	233.2	0.0612
101.33	0.082	233.2	0.0612
101.37	0.082	233.2	0.0604
101.40	0.081	233.1	0.0604
101.43	0.08	233.1	0.0604
101.47	0.08	233.1	0.0604
101.50	0.077	233	0.0595
101.53	0.079	233.1	0.0595
101.57	0.079	233.1	0.0595
101.60	0.079	233.1	0.0595
101.63	0.077	233	0.0595
101.67	0.077	233	0.0586
101.72	0.076	233	0.0586
101.75	0.076	233	0.0577
101.77	0.076	233	0.0577
101.80	0.075	233	0.0577
101.83	0.074	232.9	0.0568
101.87	0.073	232.9	0.0568
101.90	0.073	232.9	0.0568
101.93	0.073	232.9	0.0568
101.97	0.074	232.9	0.0568
102.00	0.072	232.9	0.0559
102.03	0.068	232.8	0.0559

Prova triassiale ciclica SNME01-C3			
ensione di confinamento (kPa)		380	
deviatore ciclico (kPa)		80	
frequenza (hz)		0.00071429	
tempo	cella di carico	u	LVDT
(min)	kN	(kPa)	δ (mm)
102.07	0.072	232.9	0.0559
102.10	0.072	232.9	0.0559
102.13	0.069	232.8	0.0559
102.17	0.069	232.8	0.0559
102.20	0.069	232.8	0.055
102.23	0.067	232.7	0.055
102.27	0.065	232.6	0.0541
102.30	0.065	232.6	0.0533
102.33	0.065	232.6	0.0533
102.37	0.065	232.6	0.0533
102.40	0.065	232.6	0.0533
102.43	0.064	232.6	0.0524
102.47	0.064	232.6	0.0524
102.50	0.062	232.5	0.0515
102.53	0.062	232.5	0.0506
102.57	0.061	232.5	0.0506
102.60	0.06	232.4	0.0506
102.63	0.06	232.4	0.0497
102.67	0.06	232.4	0.0497
102.70	0.059	232.4	0.0488
102.73	0.059	232.3	0.0488
102.77	0.057	232.3	0.0479
102.80	0.056	232.2	0.0479
102.83	0.055	232.2	0.047
102.87	0.055	232.2	0.0462
102.90	0.055	232.2	0.0462
102.93	0.054	232.2	0.0453
102.97	0.052	232.1	0.0444
103.00	0.053	232.1	0.0444
103.03	0.052	232	0.0444
103.07	0.051	232	0.0435
103.10	0.051	232	0.0426
103.15	0.05	231.9	0.0408
103.18	0.049	231.9	0.0408
103.20	0.049	231.9	0.0408
103.23	0.048	231.8	0.0399
103.27	0.047	231.8	0.0391
103.30	0.046	231.7	0.0382
103.33	0.045	231.7	0.0373
103.37	0.045	231.6	0.0364
103.40	0.043	231.6	0.0364
103.43	0.043	231.6	0.0355
103.47	0.043	231.6	0.0346
103.50	0.042	231.5	0.0337
103.53	0.041	231.5	0.0337
103.57	0.041	231.4	0.0328
103.60	0.04	231.4	0.032
103.63	0.038	231.3	0.032
103.67	0.038	231.3	0.0311
103.70	0.037	231.3	0.0302
103.73	0.037	231.2	0.0293
103.77	0.035	231.1	0.0275
103.80	0.035	231.1	0.0275
103.83	0.034	231.1	0.0266
103.87	0.033	231	0.0266
103.90	0.033	231	0.0257
103.93	0.032	230.9	0.024
103.97	0.031	230.9	0.0231

Prova triassiale ciclica SNME01-C3			
pressione di confinamento (kPa)		380	
deviatore ciclico (kPa)		80	
frequenza (hz)		0.00071429	
tempo	cella di carico	u	LVDT
(min)	kN	(kPa)	δ (mm)
104.00	0.03	230.8	0.0222
104.03	0.03	230.8	0.0213
104.07	0.029	230.7	0.0204
104.10	0.028	230.7	0.0204
104.13	0.028	230.7	0.0186
104.17	0.027	230.6	0.0178
104.20	0.026	230.5	0.0169
104.23	0.025	230.5	0.016
104.27	0.024	230.4	0.0151
104.30	0.023	230.3	0.0133
104.33	0.022	230.3	0.0133
104.37	0.022	230.3	0.0124
104.40	0.021	230.2	0.0115
104.43	0.021	230.2	0.0098
104.47	0.019	230.1	0.0089
104.50	0.019	230	0.008
104.53	0.018	230	0.0071
104.57	0.016	229.9	0.0071
104.62	0.016	229.8	0.0044
104.65	0.015	229.7	0.0036
104.67	0.013	229.7	0.0036
104.70	0.013	229.7	0.0018
104.73	0.014	229.7	0.0018
104.77	0.013	229.6	0
104.80	0.011	229.5	-0.0009
104.83	0.011	229.4	-0.0027
104.87	0.01	229.3	-0.0036
104.90	0.008	229.3	-0.0036
104.93	0.008	229.3	-0.0053
104.97	0.007	229.2	-0.0071
105.00	0.006	229.1	-0.008
105.03	0.005	229	-0.0089
105.07	0.005	229	-0.0098
105.10	0.004	228.9	-0.0115
105.13	0.002	228.8	-0.0115
105.17	0.002	228.8	-0.0124
105.20	0.003	228.8	-0.0142
105.23	0.001	228.7	-0.0151
105.27	0	228.6	-0.016
105.30	-0.001	228.5	-0.0178
105.33	-0.002	228.4	-0.0195
105.37	-0.003	228.4	-0.0195
105.40	-0.003	228.4	-0.0213
105.43	-0.004	228.3	-0.0222
105.47	-0.005	228.2	-0.024
105.50	-0.006	228.1	-0.0249
105.53	-0.006	228	-0.0266
105.57	-0.007	228	-0.0284
105.60	-0.008	227.9	-0.0284
105.63	-0.008	227.9	-0.0302
105.67	-0.01	227.7	-0.0328
105.70	-0.01	227.6	-0.0355
105.73	-0.012	227.5	-0.0382
105.77	-0.012	227.4	-0.0399
105.80	-0.014	227.3	-0.0426
105.83	-0.014	227.2	-0.0426
105.87	-0.014	227.2	-0.0453
105.90	-0.015	227.1	-0.047

Prova triassiale ciclica SNME01-C3			
pressione di confinamento (kPa)		380	
deviatore ciclico (kPa)		80	
frequenza (hz)		0.00071429	
tempo	cella di carico	u	LVDT
(min)	kN	(kPa)	δ (mm)
105.93	-0.016	227	-0.0497
105.97	-0.017	226.9	-0.0524
106.00	-0.018	226.8	-0.055
106.03	-0.018	226.7	-0.0586
106.08	-0.019	226.7	-0.0604
106.12	-0.02	226.6	-0.063
106.13	-0.021	226.4	-0.0657
106.17	-0.022	226.4	-0.0657
106.20	-0.022	226.4	-0.0692
106.23	-0.023	226.3	-0.0737
106.27	-0.023	226.1	-0.0817
106.30	-0.024	226	-0.0923
106.33	-0.025	225.8	-0.1074
106.37	-0.025	225.6	-0.1296
106.40	-0.028	225.4	-0.1296
106.43	-0.028	225.4	-0.1544
106.47	-0.028	225.3	-0.1624
106.50	-0.029	225.1	-0.174
106.53	-0.029	224.9	-0.1882
106.57	-0.03	224.7	-0.1944
106.60	-0.032	224.5	-0.2015
106.63	-0.032	224.4	-0.2015
106.67	-0.032	224.4	-0.2059
106.70	-0.033	224.3	-0.2113
106.73	-0.033	224.1	-0.2157
106.77	-0.035	223.9	-0.2201
106.80	-0.036	223.8	-0.2237
106.83	-0.037	223.7	-0.2272
106.87	-0.038	223.6	-0.2272
106.90	-0.038	223.6	-0.2299
106.93	-0.038	223.4	-0.2326
106.97	-0.039	223.4	-0.2352
107.00	-0.041	223.2	-0.237
107.03	-0.041	223.2	-0.2388
107.07	-0.042	223.1	-0.2423
107.10	-0.042	223	-0.2423
107.13	-0.043	223	-0.2441
107.17	-0.043	222.9	-0.2468
107.20	-0.043	222.8	-0.2494
107.23	-0.045	222.6	-0.2521
107.27	-0.045	222.5	-0.2539
107.30	-0.046	222.4	-0.2565
107.33	-0.047	222.3	-0.2565
107.37	-0.048	222.3	-0.2592
107.40	-0.048	222.2	-0.261
107.43	-0.048	222.1	-0.2636
107.47	-0.049	222	-0.2663
107.52	-0.05	221.9	-0.2681
107.55	-0.05	221.8	-0.2698
107.57	-0.051	221.7	-0.2707
107.60	-0.052	221.6	-0.2725
107.63	-0.052	221.5	-0.2743
107.67	-0.053	221.4	-0.2743
107.70	-0.054	221.4	-0.2769
107.73	-0.054	221.3	-0.2787
107.77	-0.054	221.2	-0.2805
107.80	-0.056	221.1	-0.2823
107.83	-0.056	221	-0.284

Prova triassiale ciclica SNME01-C3			
ensione di confinamento (kPa)		380	
deviatore ciclico (kPa)		80	
frequenza (hz)		0.00071429	
tempo	cella di carico	u	LVDT
(min)	kN	(kPa)	δ (mm)
107.87	-0.057	220.9	-0.2858
107.90	-0.057	220.8	-0.2858
107.93	-0.058	220.8	-0.2876
107.97	-0.058	220.7	-0.2894
108.00	-0.059	220.6	-0.2911
108.03	-0.059	220.6	-0.292
108.07	-0.06	220.5	-0.2929
108.10	-0.06	220.4	-0.2938
108.13	-0.062	220.3	-0.2938
108.17	-0.062	220.3	-0.2956
108.20	-0.062	220.2	-0.2974
108.23	-0.062	220.1	-0.2982
108.27	-0.063	220	-0.3
108.30	-0.064	219.9	-0.3009
108.33	-0.064	219.8	-0.3018
108.37	-0.065	219.8	-0.3018
108.40	-0.065	219.8	-0.3027
108.43	-0.065	219.7	-0.3045
108.47	-0.066	219.6	-0.3053
108.50	-0.067	219.5	-0.3062
108.53	-0.067	219.5	-0.3071
108.57	-0.068	219.4	-0.3089
108.60	-0.068	219.3	-0.3089
108.63	-0.069	219.3	-0.3098
108.67	-0.069	219.2	-0.3107
108.70	-0.069	219.2	-0.3116
108.73	-0.07	219.1	-0.3124
108.77	-0.07	219	-0.3133
108.80	-0.07	219	-0.3142
108.83	-0.071	218.8	-0.3142
108.87	-0.072	218.8	-0.3151
108.90	-0.072	218.8	-0.3169
108.93	-0.072	218.7	-0.3178
108.98	-0.073	218.6	-0.3187
109.02	-0.073	218.6	-0.3196
109.03	-0.073	218.5	-0.3196
109.07	-0.074	218.4	-0.3213
109.10	-0.074	218.4	-0.3213
109.13	-0.074	218.3	-0.3222
109.17	-0.076	218.2	-0.3222
109.20	-0.075	218.2	-0.324
109.23	-0.075	218.2	-0.324
109.27	-0.076	218.1	-0.3249
109.30	-0.076	218.1	-0.3258
109.33	-0.077	218	-0.3267
109.37	-0.077	217.9	-0.3275
109.40	-0.078	217.9	-0.3275
109.43	-0.078	217.9	-0.3284
109.47	-0.078	217.8	-0.3284
109.50	-0.078	217.8	-0.3293
109.53	-0.078	217.7	-0.3302
109.57	-0.079	217.7	-0.3311
109.60	-0.079	217.6	-0.3311
109.63	-0.079	217.6	-0.3311
109.67	-0.079	217.6	-0.332
109.70	-0.079	217.5	-0.3329
109.73	-0.081	217.4	-0.3338
109.77	-0.08	217.4	-0.3346

Prova triassiale ciclica SNME01-C3			
ensione di confinamento (kPa)		380	
deviatore ciclico (kPa)		80	
frequenza (hz)		0.00071429	
tempo	cella di carico	u	LVDT
(min)	kN	(kPa)	δ (mm)
109.80	-0.081	217.3	-0.3346
109.83	-0.08	217.3	-0.3355
109.87	-0.081	217.3	-0.3355
109.90	-0.082	217.3	-0.3355
109.93	-0.082	217.2	-0.3364
109.97	-0.082	217.2	-0.3373
110.00	-0.082	217.1	-0.3373
110.03	-0.082	217.1	-0.3382
110.07	-0.082	217	-0.3391
110.10	-0.083	217	-0.3391
110.13	-0.082	217	-0.3391
110.17	-0.082	217	-0.34
110.20	-0.083	216.9	-0.3409
110.23	-0.083	216.9	-0.3409
110.27	-0.083	216.8	-0.3409
110.30	-0.083	216.8	-0.3417
110.33	-0.083	216.8	-0.3417
110.37	-0.084	216.8	-0.3426
110.42	-0.084	216.7	-0.3435
110.45	-0.084	216.7	-0.3435
110.47	-0.084	216.7	-0.3435
110.50	-0.084	216.6	-0.3435
110.53	-0.084	216.6	-0.3444
110.57	-0.084	216.5	-0.3444
110.60	-0.084	216.5	-0.3453
110.63	-0.084	216.5	-0.3453
110.67	-0.084	216.5	-0.3453
110.70	-0.084	216.5	-0.3462
110.73	-0.084	216.4	-0.3462
110.77	-0.084	216.4	-0.3462
110.80	-0.084	216.4	-0.3471
110.83	-0.084	216.4	-0.3471
110.87	-0.085	216.3	-0.3471
110.90	-0.084	216.3	-0.3471
110.93	-0.084	216.3	-0.3471
110.97	-0.084	216.3	-0.348
111.00	-0.084	216.3	-0.348
111.03	-0.084	216.2	-0.348
111.07	-0.084	216.2	-0.3488
111.10	-0.084	216.2	-0.3488
111.13	-0.084	216.2	-0.3488
111.17	-0.084	216.2	-0.3488
111.20	-0.084	216.1	-0.3488
111.23	-0.084	216.1	-0.3488
111.27	-0.084	216.1	-0.3488
111.30	-0.083	216.1	-0.3488
111.33	-0.084	216.1	-0.3497
111.37	-0.083	216.1	-0.3497
111.40	-0.083	216.1	-0.3497
111.43	-0.083	216.1	-0.3497
111.47	-0.083	216.1	-0.3497
111.50	-0.083	216.1	-0.3497
111.53	-0.083	216.1	-0.3497
111.57	-0.083	216	-0.3506
111.60	-0.083	216	-0.3506
111.63	-0.082	216	-0.3497
111.67	-0.082	216	-0.3497
111.70	-0.082	216	-0.3506

Prova triassiale ciclica SNME01-C3			
pressione di confinamento (kPa)		380	
deviatore ciclico (kPa)		80	
frequenza (hz)		0.00071429	
tempo	cella di carico	u	LVDT
(min)	kN	(kPa)	δ (mm)
111.73	-0.082	216	-0.3506
111.77	-0.082	216	-0.3506
111.80	-0.082	216	-0.3506
111.83	-0.081	216	-0.3506
111.88	-0.081	216	-0.3506
111.92	-0.081	216	-0.3506
111.93	-0.08	216	-0.3506
111.97	-0.08	216	-0.3497
112.00	-0.08	216	-0.3497
112.03	-0.08	216	-0.3497
112.07	-0.08	216	-0.3506
112.10	-0.079	216	-0.3497
112.13	-0.079	216	-0.3497
112.17	-0.078	216	-0.3497
112.20	-0.078	216	-0.3497
112.23	-0.078	216.1	-0.3497
112.27	-0.078	216.1	-0.3497
112.30	-0.078	216.1	-0.3497
112.33	-0.078	216.1	-0.3497
112.37	-0.077	216.1	-0.3497
112.40	-0.076	216.1	-0.3497
112.43	-0.076	216.1	-0.3488
112.47	-0.076	216.1	-0.3488
112.50	-0.076	216.1	-0.3488
112.53	-0.075	216.1	-0.3488
112.57	-0.075	216.1	-0.3488
112.60	-0.075	216.2	-0.3488
112.63	-0.074	216.2	-0.3488
112.67	-0.074	216.2	-0.348
112.70	-0.074	216.2	-0.348
112.73	-0.073	216.2	-0.348
112.77	-0.073	216.2	-0.348
112.80	-0.072	216.3	-0.348
112.83	-0.072	216.3	-0.3471
112.87	-0.071	216.3	-0.3471
112.90	-0.07	216.3	-0.3471
112.93	-0.07	216.4	-0.3471
112.97	-0.071	216.4	-0.3471
113.00	-0.07	216.4	-0.3471
113.03	-0.069	216.4	-0.3462
113.07	-0.069	216.5	-0.3462
113.10	-0.068	216.5	-0.3462
113.13	-0.068	216.5	-0.3453
113.17	-0.068	216.5	-0.3453
113.20	-0.067	216.5	-0.3453
113.23	-0.067	216.6	-0.3453
113.27	-0.066	216.6	-0.3444
113.30	-0.066	216.6	-0.3444
113.35	-0.065	216.6	-0.3444
113.37	-0.065	216.7	-0.3444
113.40	-0.064	216.7	-0.3435
113.43	-0.063	216.8	-0.3435
113.47	-0.063	216.8	-0.3435
113.50	-0.063	216.8	-0.3426
113.53	-0.062	216.8	-0.3426
113.57	-0.061	216.9	-0.3426
113.60	-0.061	216.9	-0.3417
113.63	-0.061	216.9	-0.3417

Prova triassiale ciclica SNME01-C3			
pressione di confinamento (kPa)		380	
deviatore ciclico (kPa)		80	
frequenza (hz)		0.00071429	
tempo	cella di carico	u	LVDT
(min)	kN	(kPa)	δ (mm)
113.67	-0.06	217	-0.3417
113.70	-0.059	217	-0.3409
113.73	-0.059	217	-0.3409
113.77	-0.058	217	-0.34
113.80	-0.058	217.1	-0.34
113.83	-0.057	217.1	-0.3391
113.87	-0.057	217.2	-0.3391
113.90	-0.056	217.2	-0.3391
113.93	-0.055	217.2	-0.3391
113.97	-0.055	217.2	-0.3382
114.00	-0.054	217.3	-0.3382
114.03	-0.053	217.4	-0.3373
114.07	-0.053	217.4	-0.3373
114.10	-0.053	217.5	-0.3364
114.13	-0.051	217.5	-0.3364
114.17	-0.05	217.5	-0.3355
114.20	-0.05	217.6	-0.3355
114.23	-0.05	217.6	-0.3346
114.27	-0.049	217.7	-0.3346
114.30	-0.048	217.7	-0.3338
114.33	-0.048	217.8	-0.3338
114.37	-0.047	217.8	-0.3338
114.40	-0.046	217.8	-0.3329
114.43	-0.046	217.9	-0.332
114.47	-0.046	217.9	-0.332
114.50	-0.045	218	-0.3311
114.53	-0.044	218.1	-0.3302
114.57	-0.043	218.1	-0.3293
114.60	-0.042	218.2	-0.3293
114.63	-0.042	218.2	-0.3293
114.67	-0.042	218.2	-0.3284
114.70	-0.041	218.3	-0.3275
114.73	-0.039	218.4	-0.3267
114.78	-0.039	218.5	-0.3267
114.82	-0.038	218.5	-0.3258
114.83	-0.038	218.6	-0.3249
114.87	-0.037	218.6	-0.324
114.90	-0.036	218.7	-0.3231
114.93	-0.035	218.8	-0.3231
114.97	-0.034	218.8	-0.3222
115.00	-0.034	218.9	-0.3213
115.03	-0.033	218.9	-0.3204
115.07	-0.033	219	-0.3204
115.10	-0.032	219.1	-0.3196
115.13	-0.031	219.2	-0.3178
115.17	-0.03	219.3	-0.3178
115.20	-0.03	219.3	-0.3169
115.23	-0.03	219.3	-0.316
115.27	-0.028	219.4	-0.3142
115.30	-0.027	219.5	-0.3133
115.33	-0.027	219.6	-0.3124
115.37	-0.026	219.7	-0.3107
115.40	-0.025	219.8	-0.3107
115.43	-0.024	219.8	-0.3089
115.47	-0.024	219.9	-0.308
115.50	-0.023	220	-0.3062
115.53	-0.022	220	-0.3053
115.57	-0.021	220.1	-0.3036

Prova triassiale ciclica SNME01-C3			
pressione di confinamento (kPa)		380	
deviatore ciclico (kPa)		80	
frequenza (hz)		0.00071429	
tempo	cella di carico	u	LVDT
(min)	kN	(kPa)	δ (mm)
115.60	-0.02	220.2	-0.3018
115.63	-0.02	220.3	-0.3018
115.67	-0.019	220.3	-0.3009
115.70	-0.019	220.4	-0.2991
115.73	-0.018	220.5	-0.2974
115.77	-0.017	220.6	-0.2956
115.80	-0.016	220.7	-0.2938
115.83	-0.015	220.8	-0.292
115.87	-0.013	221	-0.292
115.90	-0.014	221	-0.2903
115.93	-0.014	221	-0.2885
115.97	-0.013	221.1	-0.2858
116.00	-0.011	221.3	-0.2832
116.03	-0.01	221.4	-0.2805
116.07	-0.009	221.5	-0.2787
116.10	-0.009	221.6	-0.2787
116.13	-0.007	221.6	-0.2761
116.17	-0.007	221.7	-0.2725
116.20	-0.007	221.8	-0.2698
116.25	-0.005	222	-0.2645
116.28	-0.005	222.1	-0.2592
116.30	-0.005	222.2	-0.2539
116.33	-0.002	222.5	-0.2477
116.37	-0.003	222.5	-0.2432
116.40	-0.002	222.7	-0.237
116.43	0	222.8	-0.237
116.47	0.001	222.8	-0.2326
116.50	0.001	223	-0.2272
116.53	0.001	223	-0.2246
116.57	0.002	223.2	-0.2201
116.60	0.003	223.3	-0.2157
116.63	0.004	223.4	-0.2113
116.67	0.005	223.5	-0.2113
116.70	0.006	223.5	-0.2059
116.73	0.006	223.6	-0.2015
116.77	0.007	223.8	-0.1971
116.80	0.008	223.9	-0.1917
116.83	0.009	224	-0.1855
116.87	0.01	224.2	-0.1811
116.90	0.011	224.3	-0.1811
116.93	0.012	224.3	-0.1784
116.97	0.012	224.3	-0.1758
117.00	0.012	224.5	-0.1722
117.03	0.015	224.6	-0.1695
117.07	0.014	224.6	-0.1669
117.10	0.016	224.8	-0.1633
117.13	0.016	225	-0.1633
117.17	0.019	225	-0.1553
117.20	0.019	225.2	-0.1465
117.23	0.018	225.2	-0.1411
117.27	0.019	225.4	-0.1349
117.30	0.02	225.5	-0.1296
117.33	0.021	225.6	-0.1234
117.37	0.022	225.7	-0.1234
117.40	0.023	225.7	-0.1172
117.43	0.023	225.8	-0.1118
117.47	0.024	226	-0.1065
117.50	0.025	226.1	-0.1012

Prova triassiale ciclica SNME01-C3			
pressione di confinamento (kPa)		380	
deviatore ciclico (kPa)		80	
frequenza (hz)		0.00071429	
tempo	cella di carico	u	LVDT
(min)	kN	(kPa)	δ (mm)
117.53	0.026	226.2	-0.0959
117.57	0.026	226.3	-0.0914
117.60	0.028	226.4	-0.0914
117.63	0.028	226.4	-0.0861
117.68	0.029	226.6	-0.0772
117.72	0.03	226.7	-0.0772
117.73	0.031	226.7	-0.0728
117.77	0.031	226.8	-0.0683
117.80	0.032	226.9	-0.0648
117.83	0.033	227	-0.0612
117.87	0.034	227.1	-0.0568
117.90	0.034	227.2	-0.0533
117.93	0.036	227.3	-0.0533
117.97	0.036	227.3	-0.0497
118.00	0.036	227.3	-0.047
118.03	0.037	227.4	-0.0444
118.07	0.039	227.5	-0.0417
118.10	0.039	227.6	-0.0399
118.13	0.04	227.6	-0.0373
118.17	0.041	227.7	-0.0373
118.20	0.041	227.7	-0.0364
118.23	0.041	227.8	-0.0337
118.27	0.042	227.8	-0.0328
118.30	0.044	228	-0.0311
118.33	0.044	228	-0.0293
118.37	0.045	228.1	-0.0275
118.40	0.047	228.2	-0.0275
118.43	0.046	228.2	-0.0266
118.47	0.046	228.2	-0.0249
118.50	0.047	228.3	-0.0231
118.53	0.049	228.4	-0.0222
118.57	0.049	228.5	-0.0213
118.60	0.05	228.5	-0.0195
118.63	0.052	228.6	-0.0195
118.67	0.052	228.6	-0.0186
118.70	0.052	228.7	-0.0178
118.73	0.052	228.7	-0.0169
118.77	0.053	228.8	-0.0151
118.80	0.055	228.9	-0.0142
118.83	0.054	229	-0.0133
118.87	0.056	229.1	-0.0133
118.90	0.056	229.1	-0.0115
118.93	0.056	229.1	-0.0107
118.97	0.057	229.2	-0.0098
119.00	0.059	229.3	-0.008
119.03	0.059	229.4	-0.0071
119.07	0.059	229.5	-0.0062
119.10	0.06	229.5	-0.0062
119.15	0.061	229.6	-0.0036
119.18	0.061	229.7	-0.0027
119.20	0.063	229.8	-0.0027
119.23	0.063	229.8	-0.0018
119.27	0.063	229.8	-0.0009
119.30	0.064	229.9	0.0009
119.33	0.067	230	0.0018
119.37	0.063	230	0.0018
119.40	0.065	230.1	0.0027
119.43	0.07	230.3	0.0027

Prova triassiale ciclica SNME01-C3			
pressione di confinamento (kPa)		380	
deviatore ciclico (kPa)		80	
frequenza (hz)		0.00071429	
tempo	cella di carico	u	LVDT
(min)	kN	(kPa)	δ (mm)
119.47	0.069	230.3	0.0053
119.50	0.069	230.3	0.0062
119.53	0.065	230.3	0.0053
119.57	0.068	230.4	0.0071
119.60	0.069	230.5	0.008
119.63	0.07	230.5	0.0089
119.67	0.071	230.6	0.0089
119.70	0.071	230.6	0.0098
119.73	0.071	230.7	0.0107
119.77	0.071	230.8	0.0124
119.80	0.075	230.9	0.0133
119.83	0.072	230.9	0.0133
119.87	0.073	231	0.0151
119.90	0.074	231	0.0151
119.93	0.076	231	0.016
119.97	0.076	231.1	0.0169
120.00	0.076	231.2	0.0178
120.03	0.076	231.2	0.0178
120.07	0.077	231.3	0.0186
120.10	0.077	231.3	0.0195
120.13	0.078	231.4	0.0195
120.17	0.078	231.4	0.0204
120.20	0.078	231.5	0.0213
120.23	0.08	231.6	0.0222
120.27	0.079	231.6	0.0231
120.30	0.08	231.7	0.024
120.33	0.081	231.7	0.0249
120.37	0.081	231.8	0.0249
120.40	0.081	231.8	0.0257
120.43	0.081	231.8	0.0266
120.47	0.084	232	0.0284
120.50	0.085	232.1	0.0293
120.53	0.084	232.1	0.0293
120.58	0.083	232.1	0.0302
120.62	0.084	232.2	0.0302
120.63	0.084	232.2	0.0311
120.67	0.085	232.3	0.032
120.70	0.086	232.4	0.032
120.73	0.086	232.4	0.0328
120.77	0.086	232.4	0.0328
120.80	0.086	232.5	0.0337
120.83	0.087	232.5	0.0337
120.87	0.087	232.6	0.0346
120.90	0.088	232.6	0.0355
120.93	0.088	232.7	0.0355
120.97	0.088	232.7	0.0355
121.00	0.088	232.8	0.0364
121.03	0.089	232.8	0.0373
121.07	0.089	232.9	0.0373
121.10	0.089	232.9	0.0382
121.13	0.09	233	0.0391
121.17	0.09	233	0.0391
121.20	0.088	233	0.0391
121.23	0.088	233	0.0391
121.27	0.091	233.2	0.0408
121.30	0.094	233.3	0.0426
121.33	0.092	233.3	0.0426
121.37	0.092	233.3	0.0426

Prova triassiale ciclica SNME01-C3			
ensione di confinamento (kPa)		380	
deviatore ciclico (kPa)		80	
frequenza (hz)		0.00071429	
tempo	cella di carico	u	LVDT
(min)	kN	(kPa)	δ (mm)
121.40	0.092	233.4	0.0426
121.43	0.093	233.4	0.0426
121.47	0.093	233.4	0.0435
121.50	0.092	233.5	0.0435
121.53	0.093	233.5	0.0444
121.57	0.093	233.6	0.0453
121.60	0.093	233.6	0.0453
121.63	0.093	233.7	0.0453
121.67	0.094	233.7	0.0462
121.70	0.094	233.7	0.0462
121.73	0.094	233.7	0.047
121.77	0.094	233.8	0.047
121.80	0.094	233.8	0.0479
121.83	0.095	233.9	0.0479
121.87	0.095	233.9	0.0479
121.90	0.094	233.9	0.0488
121.93	0.094	233.9	0.0488
121.97	0.095	234	0.0488
122.00	0.095	234	0.0497
122.05	0.095	234.1	0.0497
122.08	0.095	234.1	0.0497
122.10	0.095	234.1	0.0497
122.13	0.095	234.2	0.0506
122.17	0.096	234.2	0.0506
122.20	0.096	234.2	0.0506
122.23	0.095	234.2	0.0515
122.27	0.095	234.3	0.0515
122.30	0.094	234.2	0.0515
122.33	0.098	234.4	0.0524
122.37	0.097	234.4	0.0524
122.40	0.096	234.4	0.0524
122.43	0.095	234.4	0.0524
122.47	0.094	234.4	0.0515
122.50	0.094	234.4	0.0524
122.53	0.098	234.5	0.0533
122.57	0.094	234.5	0.0524
122.60	0.096	234.5	0.0533
122.63	0.098	234.6	0.0541
122.67	0.097	234.6	0.0541
122.70	0.096	234.6	0.0541
122.73	0.096	234.6	0.0541
122.77	0.096	234.7	0.0533
122.80	0.095	234.7	0.0541
122.83	0.096	234.7	0.0541
122.87	0.095	234.7	0.0541
122.90	0.095	234.7	0.0541
122.93	0.095	234.7	0.0541
122.97	0.095	234.8	0.0541
123.00	0.095	234.8	0.0541
123.03	0.095	234.8	0.0541
123.07	0.095	234.8	0.0541
123.10	0.095	234.9	0.0541
123.13	0.095	234.9	0.0541
123.17	0.094	234.9	0.0541
123.20	0.094	234.9	0.0541
123.23	0.095	234.9	0.0541
123.27	0.094	234.9	0.0541
123.30	0.094	234.9	0.0541

Prova triassiale ciclica SNME01-C3			
ensione di confinamento (kPa)		380	
deviatore ciclico (kPa)		80	
frequenza (hz)		0.00071429	
tempo	cella di carico	u	LVDT
(min)	kN	(kPa)	δ (mm)
123.33	0.094	235	0.0541
123.37	0.094	235	0.0541
123.40	0.093	235	0.0541
123.43	0.093	235	0.0541
123.47	0.093	235	0.0541
123.52	0.093	235	0.0541
123.55	0.093	235	0.0541
123.57	0.093	235	0.0541
123.60	0.092	235	0.0541
123.63	0.092	235.1	0.0541
123.67	0.089	235	0.0533
123.70	0.093	235.1	0.0533
123.73	0.092	235.1	0.0541
123.77	0.092	235.1	0.0541
123.80	0.091	235.1	0.0541
123.83	0.091	235.1	0.0541
123.87	0.087	235	0.0533
123.90	0.092	235.2	0.0541
123.93	0.091	235.2	0.0541
123.97	0.09	235.1	0.0541
124.00	0.09	235.1	0.0533
124.03	0.089	235.1	0.0533
124.07	0.086	235	0.0524
124.10	0.088	235.1	0.0533
124.13	0.089	235.1	0.0524
124.17	0.085	235	0.0524
124.20	0.088	235.1	0.0524
124.23	0.088	235.1	0.0533
124.27	0.087	235.1	0.0524
124.30	0.083	235	0.0515
124.33	0.084	235	0.0524
124.37	0.085	235.1	0.0524
124.40	0.088	235.2	0.0524
124.43	0.085	235.1	0.0524
124.47	0.085	235.1	0.0515
124.50	0.084	235.1	0.0515
124.53	0.083	235.1	0.0515
124.57	0.08	235	0.0506
124.60	0.084	235.1	0.0515
124.63	0.084	235.1	0.0515
124.67	0.082	235.1	0.0515
124.70	0.082	235	0.0506
124.73	0.078	234.9	0.0497
124.77	0.081	235	0.0506
124.80	0.08	235	0.0488
124.83	0.076	234.9	0.0488
124.87	0.08	235	0.0488
124.90	0.076	235	0.0497
124.95	0.077	234.9	0.0497
124.98	0.08	235	0.0497
125.00	0.077	235	0.0497
125.03	0.077	235	0.0488
125.07	0.077	234.9	0.0479
125.10	0.075	234.9	0.0479
125.13	0.072	234.8	0.0462
125.17	0.075	234.9	0.047
125.20	0.075	234.9	0.047
125.23	0.071	234.7	0.047

Prova triassiale ciclica SNME01-C3			
pressione di confinamento (kPa)		380	
deviatore ciclico (kPa)		80	
frequenza (hz)		0.00071429	
tempo	cella di carico	u	LVDT
(min)	kN	(kPa)	δ (mm)
125.27	0.071	234.7	0.0462
125.30	0.074	234.8	0.0462
125.33	0.072	234.8	0.0462
125.37	0.071	234.7	0.0453
125.40	0.07	234.7	0.0453
125.43	0.07	234.7	0.0453
125.47	0.069	234.7	0.0444
125.50	0.069	234.7	0.0444
125.53	0.069	234.6	0.0435
125.57	0.068	234.6	0.0435
125.60	0.066	234.6	0.0426
125.63	0.066	234.6	0.0426
125.67	0.066	234.5	0.0426
125.70	0.064	234.5	0.0417
125.73	0.064	234.5	0.0408
125.77	0.062	234.4	0.0399
125.80	0.065	234.5	0.0408
125.83	0.063	234.4	0.0399
125.87	0.062	234.4	0.0399
125.90	0.058	234.3	0.0399
125.93	0.059	234.2	0.0382
125.97	0.059	234.2	0.0382
126.00	0.06	234.3	0.0382
126.03	0.062	234.3	0.0382
126.07	0.059	234.2	0.0373
126.10	0.058	234.2	0.0364
126.13	0.057	234.2	0.0364
126.17	0.055	234.1	0.0355
126.20	0.055	234.1	0.0346
126.23	0.055	234.1	0.0346
126.27	0.054	234.1	0.0337
126.30	0.053	234	0.0328
126.33	0.053	234	0.0328
126.37	0.052	233.9	0.0328
126.42	0.051	233.9	0.0311
126.45	0.051	233.9	0.0311
126.47	0.049	233.8	0.0311
126.50	0.049	233.8	0.0302
126.53	0.049	233.8	0.0293
126.57	0.046	233.7	0.0275
126.60	0.048	233.7	0.0275
126.63	0.047	233.7	0.0266
126.67	0.046	233.6	0.0257
126.70	0.045	233.5	0.0257
126.73	0.043	233.5	0.0257
126.77	0.043	233.5	0.0249
126.80	0.042	233.4	0.024
126.83	0.042	233.4	0.0222
126.87	0.038	233.2	0.0204
126.90	0.04	233.3	0.0204
126.93	0.042	233.3	0.0204
126.97	0.039	233.2	0.0204
127.00	0.039	233.2	0.0195
127.03	0.038	233.2	0.0186
127.07	0.035	232.9	0.0169
127.10	0.037	233	0.0169
127.13	0.035	232.9	0.0142
127.17	0.034	232.9	0.0142

Prova triassiale ciclica SNME01-C3			
pressione di confinamento (kPa)		380	
deviatore ciclico (kPa)		80	
frequenza (hz)		0.00071429	
tempo	cella di carico	u	LVDT
(min)	kN	(kPa)	δ (mm)
127.20	0.033	232.8	0.0142
127.23	0.033	232.8	0.0133
127.27	0.032	232.8	0.0124
127.30	0.031	232.7	0.0115
127.33	0.03	232.6	0.0107
127.37	0.03	232.6	0.0098
127.40	0.029	232.5	0.0098
127.43	0.028	232.5	0.0089
127.47	0.028	232.5	0.008
127.50	0.027	232.4	0.0062
127.53	0.025	232.3	0.0053
127.57	0.025	232.3	0.0036
127.60	0.024	232.2	0.0027
127.63	0.023	232.1	0.0027
127.67	0.022	232.1	0.0018
127.70	0.022	232.1	0.0009
127.73	0.021	232	0
127.77	0.02	231.9	-0.0009
127.80	0.02	231.9	-0.0027
127.85	0.018	231.8	-0.0036
127.88	0.019	231.8	-0.0044
127.90	0.017	231.7	-0.0053
127.93	0.016	231.7	-0.0071
127.97	0.015	231.6	-0.0071
128.00	0.012	231.4	-0.008
128.03	0.012	231.4	-0.0098
128.07	0.013	231.4	-0.0107
128.10	0.014	231.4	-0.0107
128.13	0.012	231.3	-0.0124
128.17	0.011	231.2	-0.0142
128.20	0.008	231.1	-0.0142
128.23	0.009	231.1	-0.016
128.27	0.009	231.1	-0.0169
128.30	0.008	231	-0.0178
128.33	0.005	230.9	-0.0195
128.37	0.006	230.8	-0.0213
128.40	0.005	230.8	-0.0222
128.43	0.003	230.7	-0.0222
128.47	0.003	230.7	-0.0222
128.50	0.003	230.7	-0.024
128.53	0.002	230.6	-0.0257
128.57	0	230.5	-0.0266
128.60	-0.001	230.4	-0.0284
128.63	0	230.4	-0.0293
128.67	-0.001	230.2	-0.0293
128.70	-0.004	230.2	-0.0302
128.73	-0.004	230.2	-0.032
128.77	-0.003	230.2	-0.0328
128.80	-0.004	230	-0.0346
128.83	-0.006	230	-0.0364
128.87	-0.006	229.9	-0.0373
128.90	-0.007	229.7	-0.0373
128.93	-0.009	229.7	-0.0391
128.97	-0.009	229.7	-0.0408
129.00	-0.01	229.5	-0.0435
129.03	-0.011	229.4	-0.0462
129.07	-0.011	229.3	-0.0479
129.10	-0.012	229.2	-0.0497

Prova triassiale ciclica SNME01-C3			
pressione di confinamento (kPa)		380	
deviatore ciclico (kPa)		80	
frequenza (hz)		0.00071429	
tempo	cella di carico	u	LVDT
(min)	kN	(kPa)	δ (mm)
129.13	-0.014	229.1	-0.0497
129.17	-0.014	229	-0.0524
129.20	-0.014	229	-0.0541
129.23	-0.015	229	-0.0559
129.27	-0.016	228.8	-0.0595
129.32	-0.017	228.7	-0.0612
129.35	-0.017	228.7	-0.0639
129.37	-0.018	228.5	-0.0683
129.40	-0.019	228.4	-0.0737
129.43	-0.02	228.3	-0.0799
129.47	-0.021	228.2	-0.0799
129.50	-0.022	228.1	-0.0861
129.53	-0.022	228.1	-0.0932
129.57	-0.022	228	-0.103
129.60	-0.024	227.8	-0.1154
129.63	-0.025	227.6	-0.1349
129.67	-0.025	227.4	-0.158
129.70	-0.026	227.1	-0.158
129.73	-0.028	226.9	-0.1749
129.77	-0.028	226.9	-0.1829
129.80	-0.028	226.8	-0.1864
129.83	-0.029	226.7	-0.1891
129.87	-0.03	226.6	-0.1908
129.90	-0.03	226.5	-0.1944
129.93	-0.03	226.3	-0.1944
129.97	-0.033	226.1	-0.2033
130.00	-0.033	226.1	-0.2095
130.03	-0.034	226	-0.213
130.07	-0.034	225.9	-0.2166
130.10	-0.035	225.7	-0.221
130.13	-0.035	225.7	-0.2228
130.17	-0.036	225.6	-0.2228
130.20	-0.038	225.4	-0.2255
130.23	-0.038	225.4	-0.2272
130.27	-0.038	225.4	-0.2299
130.30	-0.039	225.2	-0.2317
130.33	-0.041	225.1	-0.2343
130.37	-0.04	225	-0.2361
130.40	-0.041	224.9	-0.2361
130.43	-0.043	224.8	-0.2379
130.47	-0.043	224.8	-0.2406
130.50	-0.043	224.8	-0.2423
130.53	-0.044	224.6	-0.2441
130.57	-0.044	224.5	-0.2459
130.60	-0.045	224.4	-0.2477
130.63	-0.046	224.3	-0.2477
130.67	-0.047	224.2	-0.2503
130.70	-0.047	224.2	-0.2521
130.73	-0.048	224.1	-0.2539
130.78	-0.049	223.9	-0.2556
130.80	-0.049	223.9	-0.2583
130.83	-0.05	223.8	-0.261
130.87	-0.05	223.7	-0.2627
130.90	-0.051	223.6	-0.2654
130.93	-0.052	223.5	-0.2672
130.97	-0.052	223.4	-0.2672
131.00	-0.054	223.2	-0.2698
131.03	-0.054	223.2	-0.2716

Prova triassiale ciclica SNME01-C3			
pressione di confinamento (kPa)		380	
deviatore ciclico (kPa)		80	
frequenza (hz)		0.00071429	
tempo	cella di carico	u	LVDT
(min)	kN	(kPa)	δ (mm)
131.07	-0.054	223.2	-0.2725
131.10	-0.054	223.1	-0.2734
131.13	-0.055	223	-0.2743
131.17	-0.055	222.9	-0.2761
131.20	-0.057	222.7	-0.2761
131.23	-0.057	222.7	-0.2796
131.27	-0.057	222.7	-0.2814
131.30	-0.058	222.6	-0.2823
131.33	-0.059	222.5	-0.2858
131.37	-0.06	222.4	-0.2876
131.40	-0.06	222.3	-0.2885
131.43	-0.061	222.2	-0.2903
131.47	-0.061	222.1	-0.2903
131.50	-0.061	222.1	-0.2911
131.53	-0.062	222	-0.2929
131.57	-0.063	221.9	-0.2938
131.60	-0.064	221.8	-0.2956
131.63	-0.063	221.8	-0.2965
131.67	-0.064	221.7	-0.2974
131.70	-0.066	221.6	-0.2974
131.73	-0.066	221.6	-0.2991
131.77	-0.065	221.5	-0.3
131.80	-0.066	221.4	-0.3009
131.83	-0.067	221.3	-0.3027
131.87	-0.067	221.2	-0.3036
131.90	-0.068	221.1	-0.3053
131.93	-0.068	221	-0.3053
131.97	-0.068	221	-0.3062
132.00	-0.068	221	-0.3071
132.03	-0.069	220.9	-0.308
132.07	-0.07	220.8	-0.3098
132.10	-0.071	220.7	-0.3098
132.13	-0.071	220.7	-0.3107
132.17	-0.072	220.6	-0.3107
132.22	-0.071	220.5	-0.3124
132.25	-0.072	220.4	-0.3133
132.27	-0.073	220.4	-0.3133
132.30	-0.073	220.4	-0.3142
132.33	-0.073	220.3	-0.3151
132.37	-0.074	220.2	-0.316
132.40	-0.074	220.1	-0.3169
132.43	-0.075	220.1	-0.3169
132.47	-0.075	220	-0.3178
132.50	-0.076	220	-0.3178
132.53	-0.075	220	-0.3187
132.57	-0.075	219.9	-0.3196
132.60	-0.076	219.8	-0.3204
132.63	-0.076	219.8	-0.3213
132.67	-0.077	219.7	-0.3222
132.70	-0.077	219.6	-0.3222
132.73	-0.077	219.6	-0.3222
132.77	-0.078	219.6	-0.3231
132.80	-0.078	219.5	-0.324
132.83	-0.078	219.5	-0.3249
132.87	-0.078	219.4	-0.3249
132.90	-0.079	219.4	-0.3258
132.93	-0.079	219.3	-0.3267
132.97	-0.079	219.2	-0.3267

Prova triassiale ciclica SNME01-C3			
ensione di confinamento (kPa)		380	
deviatore ciclico (kPa)		80	
frequenza (hz)		0.00071429	
tempo	cella di carico	u	LVDT
(min)	kN	(kPa)	δ (mm)
133.00	-0.08	219.2	-0.3267
133.03	-0.08	219.2	-0.3275
133.07	-0.08	219.1	-0.3284
133.10	-0.081	219.1	-0.3293
133.13	-0.081	219	-0.3293
133.17	-0.081	219	-0.3302
133.20	-0.081	218.9	-0.3302
133.23	-0.082	218.9	-0.3302
133.27	-0.082	218.9	-0.3311
133.30	-0.081	218.9	-0.3311
133.33	-0.082	218.8	-0.332
133.37	-0.082	218.7	-0.3329
133.40	-0.083	218.7	-0.3329
133.43	-0.082	218.7	-0.3329
133.47	-0.083	218.7	-0.3338
133.50	-0.083	218.6	-0.3338
133.53	-0.082	218.6	-0.3346
133.57	-0.083	218.5	-0.3355
133.60	-0.083	218.5	-0.3355
133.63	-0.083	218.4	-0.3355
133.68	-0.083	218.4	-0.3364
133.72	-0.084	218.3	-0.3364
133.73	-0.083	218.3	-0.3373
133.77	-0.084	218.3	-0.3373
133.80	-0.084	218.3	-0.3373
133.83	-0.084	218.2	-0.3382
133.87	-0.084	218.2	-0.3382
133.90	-0.084	218.2	-0.3391
133.93	-0.084	218.1	-0.3391
133.97	-0.084	218.1	-0.3391
134.00	-0.084	218.1	-0.3391
134.03	-0.084	218.1	-0.34
134.07	-0.084	218.1	-0.34
134.10	-0.084	218	-0.34
134.13	-0.084	218	-0.3409
134.17	-0.084	218	-0.3409
134.20	-0.084	218	-0.3409
134.23	-0.085	217.9	-0.3409
134.27	-0.084	217.9	-0.3417
134.30	-0.084	217.9	-0.3417
134.33	-0.084	217.9	-0.3417
134.37	-0.084	217.9	-0.3417
134.40	-0.084	217.8	-0.3417
134.43	-0.084	217.8	-0.3417
134.47	-0.084	217.8	-0.3417
134.50	-0.084	217.8	-0.3417
134.53	-0.084	217.8	-0.3426
134.57	-0.084	217.8	-0.3426
134.60	-0.084	217.8	-0.3426
134.63	-0.084	217.7	-0.3426
134.67	-0.084	217.7	-0.3435
134.70	-0.083	217.7	-0.3435
134.73	-0.084	217.7	-0.3435
134.77	-0.084	217.7	-0.3435
134.80	-0.083	217.7	-0.3435
134.83	-0.083	217.7	-0.3435
134.87	-0.083	217.7	-0.3435
134.90	-0.083	217.7	-0.3435

Prova triassiale ciclica SNME01-C3			
pressione di confinamento (kPa)		380	
deviatore ciclico (kPa)		80	
frequenza (hz)		0.00071429	
tempo	cella di carico	u	LVDT
(min)	kN	(kPa)	δ (mm)
134.93	-0.083	217.7	-0.3435
134.97	-0.082	217.7	-0.3435
135.00	-0.082	217.7	-0.3435
135.03	-0.082	217.7	-0.3435
135.07	-0.082	217.6	-0.3435
135.12	-0.082	217.6	-0.3435
135.15	-0.081	217.6	-0.3435
135.17	-0.081	217.6	-0.3435
135.20	-0.081	217.7	-0.3435
135.23	-0.081	217.6	-0.3435
135.27	-0.081	217.6	-0.3435
135.30	-0.08	217.6	-0.3435
135.33	-0.08	217.6	-0.3435
135.37	-0.08	217.7	-0.3435
135.40	-0.08	217.6	-0.3435
135.43	-0.079	217.7	-0.3435
135.47	-0.079	217.7	-0.3435
135.50	-0.078	217.7	-0.3435
135.53	-0.078	217.7	-0.3426
135.57	-0.078	217.7	-0.3426
135.60	-0.078	217.7	-0.3426
135.63	-0.078	217.7	-0.3426
135.67	-0.077	217.7	-0.3426
135.70	-0.077	217.7	-0.3426
135.73	-0.076	217.7	-0.3426
135.77	-0.076	217.7	-0.3426
135.80	-0.076	217.8	-0.3417
135.83	-0.076	217.8	-0.3417
135.87	-0.076	217.8	-0.3417
135.90	-0.075	217.8	-0.3417
135.93	-0.075	217.8	-0.3417
135.97	-0.073	217.8	-0.3417
136.00	-0.074	217.8	-0.3409
136.03	-0.074	217.8	-0.3409
136.07	-0.074	217.8	-0.3409
136.10	-0.073	217.9	-0.3409
136.13	-0.072	217.9	-0.3409
136.17	-0.072	217.9	-0.34
136.20	-0.071	218	-0.34
136.23	-0.071	218	-0.34
136.27	-0.071	218	-0.34
136.30	-0.071	218	-0.34
136.33	-0.07	218	-0.3391
136.37	-0.069	218	-0.3391
136.40	-0.069	218	-0.3391
136.43	-0.068	218.1	-0.3391
136.47	-0.068	218.1	-0.3391
136.50	-0.068	218.1	-0.3382
136.53	-0.067	218.1	-0.3382
136.58	-0.066	218.2	-0.3382
136.62	-0.066	218.2	-0.3373
136.63	-0.066	218.2	-0.3373
136.67	-0.065	218.3	-0.3373
136.70	-0.065	218.3	-0.3364
136.73	-0.064	218.3	-0.3364
136.77	-0.063	218.4	-0.3364
136.80	-0.063	218.4	-0.3364
136.83	-0.063	218.4	-0.3355

Prova triassiale ciclica SNME01-C3			
pressione di confinamento (kPa)		380	
deviatore ciclico (kPa)		80	
frequenza (hz)		0.00071429	
tempo	cella di carico	u	LVDT
(min)	kN	(kPa)	δ (mm)
136.87	-0.062	218.4	-0.3355
136.90	-0.061	218.5	-0.3346
136.93	-0.061	218.5	-0.3346
136.97	-0.061	218.5	-0.3346
137.00	-0.059	218.6	-0.3346
137.03	-0.059	218.6	-0.3338
137.07	-0.059	218.6	-0.3338
137.10	-0.058	218.7	-0.3329
137.13	-0.057	218.8	-0.3329
137.17	-0.057	218.8	-0.3329
137.20	-0.056	218.8	-0.332
137.23	-0.055	218.9	-0.332
137.27	-0.056	218.9	-0.332
137.30	-0.056	218.9	-0.3311
137.33	-0.054	219	-0.3302
137.37	-0.053	219	-0.3302
137.40	-0.053	219.1	-0.3302
137.43	-0.052	219.1	-0.3293
137.47	-0.051	219.2	-0.3293
137.50	-0.051	219.2	-0.3284
137.53	-0.051	219.2	-0.3284
137.57	-0.05	219.3	-0.3275
137.60	-0.049	219.3	-0.3267
137.63	-0.048	219.4	-0.3267
137.67	-0.048	219.4	-0.3267
137.70	-0.047	219.5	-0.3267
137.73	-0.046	219.5	-0.3258
137.77	-0.046	219.6	-0.3249
137.80	-0.046	219.6	-0.3249
137.83	-0.044	219.7	-0.324
137.87	-0.044	219.7	-0.3231
137.90	-0.043	219.8	-0.3222
137.93	-0.041	219.9	-0.3222
137.97	-0.041	219.9	-0.3213
138.02	-0.041	220	-0.3204
138.05	-0.04	220	-0.3204
138.07	-0.039	220	-0.3196
138.10	-0.039	220.1	-0.3196
138.13	-0.039	220.2	-0.3187
138.17	-0.037	220.3	-0.3178
138.20	-0.038	220.3	-0.3169
138.23	-0.036	220.4	-0.3151
138.27	-0.035	220.5	-0.3151
138.30	-0.034	220.5	-0.3142
138.33	-0.034	220.6	-0.3133
138.37	-0.033	220.7	-0.3124
138.40	-0.033	220.7	-0.3116
138.43	-0.031	220.8	-0.3107
138.47	-0.031	220.9	-0.3098
138.50	-0.03	221	-0.3098
138.53	-0.03	221	-0.308
138.57	-0.03	221.1	-0.3071
138.60	-0.029	221.2	-0.3053
138.63	-0.027	221.3	-0.3045
138.67	-0.027	221.4	-0.3027
138.70	-0.026	221.5	-0.3018
138.73	-0.025	221.6	-0.3018
138.77	-0.023	221.6	-0.3

Prova triassiale ciclica SNME01-C3			
pressione di confinamento (kPa)		380	
deviatore ciclico (kPa)		80	
frequenza (hz)		0.00071429	
tempo	cella di carico	u	LVDT
(min)	kN	(kPa)	δ (mm)
138.80	-0.023	221.7	-0.2991
138.83	-0.023	221.7	-0.2974
138.87	-0.022	221.8	-0.2956
138.90	-0.021	221.9	-0.2947
138.93	-0.021	222	-0.2929
138.97	-0.019	222.1	-0.2929
139.00	-0.019	222.1	-0.2911
139.03	-0.019	222.2	-0.2894
139.07	-0.018	222.3	-0.2876
139.10	-0.017	222.4	-0.2858
139.13	-0.016	222.5	-0.2823
139.17	-0.015	222.6	-0.2805
139.20	-0.014	222.7	-0.2805
139.23	-0.013	222.7	-0.2778
139.27	-0.013	222.8	-0.2752
139.30	-0.013	223	-0.2716
139.33	-0.011	223.1	-0.269
139.37	-0.01	223.2	-0.2645
139.40	-0.01	223.3	-0.2619
139.43	-0.008	223.5	-0.2619
139.48	-0.009	223.6	-0.2548
139.52	-0.007	223.7	-0.2512
139.53	-0.006	223.8	-0.2512
139.57	-0.005	223.8	-0.2468
139.60	-0.005	224	-0.2432
139.63	-0.005	224.1	-0.2397
139.67	-0.003	224.2	-0.2352
139.70	-0.002	224.3	-0.2317
139.73	-0.002	224.4	-0.2281
139.77	-0.001	224.5	-0.2281
139.80	0	224.5	-0.2237
139.83	0	224.6	-0.2192
139.87	0.001	224.8	-0.2139
139.90	0.002	225	-0.2095
139.93	0.004	225.1	-0.2042
139.97	0.003	225.2	-0.1997
140.00	0.006	225.4	-0.1997
140.03	0.006	225.4	-0.1935
140.07	0.006	225.5	-0.1891
140.10	0.007	225.6	-0.1855
140.13	0.008	225.7	-0.182
140.17	0.009	225.8	-0.1784
140.20	0.01	225.9	-0.1749
140.23	0.011	226	-0.1749
140.27	0.012	226	-0.1722
140.30	0.012	226.1	-0.1704
140.33	0.013	226.2	-0.1669
140.37	0.014	226.3	-0.1633
140.40	0.015	226.4	-0.1589
140.43	0.015	226.5	-0.1553
140.47	0.016	226.6	-0.1553
140.50	0.017	226.6	-0.1509
140.53	0.017	226.8	-0.1429
140.57	0.018	226.9	-0.1367
140.60	0.02	227.1	-0.1305
140.63	0.02	227.2	-0.1252
140.67	0.021	227.3	-0.1198
140.70	0.022	227.4	-0.1198

Prova triassiale ciclica SNME01-C3			
pressione di confinamento (kPa)		380	
deviatore ciclico (kPa)		80	
frequenza (hz)		0.00071429	
tempo	cella di carico	u	LVDT
(min)	kN	(kPa)	δ (mm)
140.73	0.023	227.4	-0.1145
140.77	0.023	227.5	-0.1092
140.80	0.024	227.7	-0.103
140.83	0.025	227.8	-0.0985
140.87	0.026	227.9	-0.0932
140.90	0.026	228	-0.0888
140.95	0.028	228.1	-0.0843
140.97	0.027	228.2	-0.0808
141.00	0.029	228.3	-0.0763
141.03	0.031	228.5	-0.0763
141.07	0.031	228.5	-0.0719
141.10	0.031	228.5	-0.0675
141.13	0.032	228.6	-0.0639
141.17	0.033	228.8	-0.0595
141.20	0.033	228.8	-0.055
141.23	0.034	229	-0.0515
141.27	0.036	229.1	-0.0515
141.30	0.036	229.1	-0.0488
141.33	0.036	229.1	-0.0462
141.37	0.037	229.2	-0.0435
141.40	0.038	229.3	-0.0417
141.43	0.039	229.3	-0.0399
141.47	0.04	229.4	-0.0382
141.50	0.041	229.5	-0.0382
141.53	0.042	229.5	-0.0364
141.57	0.042	229.5	-0.0346
141.60	0.042	229.6	-0.0337
141.63	0.043	229.7	-0.032
141.67	0.044	229.8	-0.0302
141.70	0.045	229.8	-0.0293
141.73	0.046	230	-0.0293
141.77	0.046	230	-0.0275
141.80	0.046	230	-0.0266
141.83	0.048	230.1	-0.0249
141.87	0.049	230.2	-0.024
141.90	0.049	230.2	-0.0222
141.93	0.05	230.3	-0.0213
141.97	0.051	230.4	-0.0213
142.00	0.052	230.4	-0.0195
142.03	0.052	230.5	-0.0186
142.07	0.052	230.5	-0.0178
142.10	0.054	230.6	-0.0169
142.13	0.054	230.7	-0.016
142.17	0.054	230.8	-0.0142
142.20	0.056	230.8	-0.0142
142.23	0.057	230.8	-0.0133
142.27	0.057	230.9	-0.0124
142.30	0.057	231	-0.0107
142.33	0.058	231.1	-0.0098
142.38	0.059	231.1	-0.0089
142.42	0.059	231.2	-0.008
142.43	0.06	231.3	-0.0071
142.47	0.061	231.3	-0.0053
142.50	0.061	231.4	-0.0053
142.53	0.063	231.5	-0.0053
142.57	0.062	231.5	-0.0036
142.60	0.062	231.5	-0.0027
142.63	0.064	231.6	-0.0018

Prova triassiale ciclica SNME01-C3			
pressione di confinamento (kPa)		380	
deviatore ciclico (kPa)		80	
frequenza (hz)		0.00071429	
tempo	cella di carico	u	LVDT
(min)	kN	(kPa)	δ (mm)
142.67	0.064	231.7	-0.0009
142.70	0.065	231.8	0
142.73	0.066	231.8	0.0018
142.77	0.067	231.9	0.0018
142.80	0.068	231.9	0.0027
142.83	0.068	232	0.0036
142.87	0.067	232	0.0044
142.90	0.069	232.1	0.0053
142.93	0.069	232.2	0.0062
142.97	0.069	232.3	0.0071
143.00	0.071	232.4	0.0071
143.03	0.072	232.4	0.008
143.07	0.072	232.4	0.0089
143.10	0.071	232.5	0.0098
143.13	0.073	232.6	0.0107
143.17	0.073	232.6	0.0115
143.20	0.073	232.7	0.0124
143.23	0.074	232.8	0.0124
143.27	0.076	232.8	0.0133
143.30	0.076	232.8	0.0142
143.33	0.076	232.9	0.0151
143.37	0.076	232.9	0.016
143.40	0.076	233	0.0169
143.43	0.077	233.1	0.0178
143.47	0.078	233.2	0.0178
143.50	0.079	233.2	0.0186
143.53	0.079	233.3	0.0195
143.57	0.079	233.3	0.0204
143.60	0.079	233.4	0.0213
143.63	0.081	233.5	0.0222
143.67	0.081	233.5	0.0231
143.70	0.083	233.6	0.0231
143.73	0.079	233.6	0.024
143.77	0.079	233.6	0.024
143.80	0.081	233.7	0.0249
143.85	0.084	233.8	0.0257
143.88	0.084	233.8	0.0266
143.90	0.084	233.9	0.0275
143.93	0.083	233.9	0.0275
143.97	0.084	234	0.0284
144.00	0.085	234.1	0.0293
144.03	0.088	234.2	0.0293
144.07	0.084	234.2	0.0302
144.10	0.084	234.1	0.0302
144.13	0.085	234.2	0.0311
144.17	0.088	234.3	0.0328
144.20	0.087	234.3	0.0328
144.23	0.088	234.4	0.0337
144.27	0.087	234.4	0.0337
144.30	0.089	234.4	0.0337
144.33	0.089	234.5	0.0346
144.37	0.088	234.5	0.0355
144.40	0.089	234.6	0.0355
144.43	0.09	234.7	0.0364
144.47	0.09	234.7	0.0364
144.50	0.089	234.7	0.0364
144.53	0.09	234.7	0.0373
144.57	0.09	234.8	0.0373

Prova triassiale ciclica SNME01-C3			
pressione di confinamento (kPa)		380	
deviatore ciclico (kPa)		80	
frequenza (hz)		0.00071429	
tempo	cella di carico	u	LVDT
(min)	kN	(kPa)	δ (mm)
144.60	0.09	234.9	0.0391
144.63	0.094	235	0.0399
144.67	0.092	235	0.0391
144.70	0.092	235	0.0408
144.73	0.092	235.1	0.0408
144.77	0.092	235.1	0.0408
144.80	0.092	235.1	0.0408
144.83	0.093	235.2	0.0417
144.87	0.093	235.2	0.0417
144.90	0.093	235.3	0.0426
144.93	0.093	235.3	0.0426
144.97	0.094	235.4	0.0426
145.00	0.094	235.4	0.0435
145.03	0.094	235.4	0.0435
145.07	0.094	235.5	0.0444
145.10	0.094	235.5	0.0444
145.13	0.094	235.5	0.0444
145.17	0.094	235.6	0.0453
145.20	0.094	235.6	0.0453
145.23	0.095	235.6	0.0453
145.28	0.095	235.7	0.0462
145.32	0.095	235.7	0.0462
145.33	0.094	235.7	0.0453
145.37	0.094	235.7	0.0462
145.40	0.096	235.8	0.047
145.43	0.095	235.9	0.047
145.47	0.096	235.9	0.047
145.50	0.095	235.9	0.0479
145.53	0.096	236	0.0479
145.57	0.093	236	0.0479
145.60	0.093	235.9	0.047
145.63	0.098	236.1	0.0488
145.67	0.098	236.1	0.0488
145.70	0.096	236.1	0.0488
145.73	0.096	236.1	0.0488
145.77	0.096	236.2	0.0488
145.80	0.095	236.2	0.0488
145.83	0.095	236.2	0.0488
145.87	0.094	236.1	0.0488
145.90	0.097	236.3	0.0497
145.93	0.097	236.3	0.0497
145.97	0.097	236.3	0.0497
146.00	0.096	236.3	0.0497
146.03	0.095	236.3	0.0497
146.07	0.095	236.3	0.0497
146.10	0.095	236.4	0.0506
146.13	0.096	236.4	0.0506
146.17	0.096	236.4	0.0506
146.20	0.095	236.4	0.0506
146.23	0.095	236.5	0.0506
146.27	0.095	236.5	0.0506
146.30	0.095	236.5	0.0506
146.33	0.095	236.5	0.0506
146.37	0.095	236.5	0.0506
146.40	0.093	236.5	0.0506
146.43	0.097	236.6	0.0515
146.47	0.097	236.6	0.0515
146.50	0.094	236.6	0.0515

Prova triassiale ciclica SNME01-C3			
pressione di confinamento (kPa)		380	
deviatore ciclico (kPa)		80	
frequenza (hz)		0.00071429	
tempo	cella di carico	u	LVDT
(min)	kN	(kPa)	δ (mm)
146.53	0.094	236.6	0.0506
146.57	0.092	236.5	0.0506
146.60	0.095	236.7	0.0515
146.63	0.093	236.7	0.0515
146.67	0.096	236.7	0.0515
146.70	0.092	236.6	0.0515
146.75	0.095	236.7	0.0515
146.78	0.093	236.7	0.0506
146.80	0.093	236.7	0.0506
146.83	0.093	236.7	0.0506
146.87	0.093	236.7	0.0506
146.90	0.092	236.7	0.0506
146.93	0.092	236.7	0.0506
146.97	0.092	236.8	0.0506
147.00	0.092	236.8	0.0506
147.03	0.091	236.8	0.0506
147.07	0.091	236.8	0.0506
147.10	0.091	236.8	0.0506
147.13	0.091	236.8	0.0506
147.17	0.091	236.8	0.0506
147.20	0.09	236.8	0.0506
147.23	0.09	236.8	0.0497
147.27	0.09	236.8	0.0497
147.30	0.089	236.8	0.0497
147.33	0.089	236.8	0.0497
147.37	0.089	236.8	0.0497
147.40	0.089	236.8	0.0497
147.43	0.088	236.8	0.0497
147.47	0.088	236.8	0.0497
147.50	0.087	236.8	0.0497
147.53	0.087	236.8	0.0488
147.57	0.087	236.8	0.0488
147.60	0.086	236.8	0.0488
147.63	0.086	236.8	0.0488
147.67	0.086	236.8	0.0488
147.70	0.086	236.8	0.0488
147.73	0.084	236.8	0.0488
147.77	0.084	236.8	0.0479
147.80	0.084	236.8	0.0479
147.83	0.084	236.7	0.0479
147.87	0.083	236.7	0.0479
147.90	0.083	236.7	0.0479
147.93	0.082	236.7	0.047
147.97	0.082	236.7	0.047
148.00	0.081	236.7	0.047
148.03	0.081	236.7	0.047
148.07	0.077	236.6	0.0462
148.10	0.081	236.7	0.047
148.13	0.081	236.7	0.047
148.18	0.08	236.7	0.0462
148.22	0.078	236.6	0.0453
148.23	0.078	236.6	0.0453
148.27	0.078	236.6	0.0453
148.30	0.074	236.5	0.0453
148.33	0.074	236.5	0.0444
148.37	0.074	236.5	0.0444
148.40	0.079	236.7	0.0453
148.43	0.075	236.6	0.0444

Prova triassiale ciclica SNME01-C3			
pressione di confinamento (kPa)		380	
deviatore ciclico (kPa)		80	
frequenza (hz)		0.00071429	
tempo	cella di carico	u	LVDT
(min)	kN	(kPa)	δ (mm)
148.47	0.077	236.6	0.0444
148.50	0.075	236.5	0.0435
148.53	0.073	236.5	0.0435
148.57	0.073	236.5	0.0435
148.60	0.073	236.5	0.0426
148.63	0.072	236.4	0.0426
148.67	0.072	236.4	0.0426
148.70	0.071	236.4	0.0417
148.73	0.071	236.4	0.0417
148.77	0.07	236.3	0.0417
148.80	0.069	236.3	0.0408
148.83	0.069	236.3	0.0408
148.87	0.068	236.3	0.0399
148.90	0.067	236.3	0.0399
148.93	0.067	236.2	0.0391
148.97	0.067	236.2	0.0382
149.00	0.062	236.1	0.0382
149.03	0.063	236.1	0.0373
149.07	0.063	236.1	0.0373
149.10	0.066	236.2	0.0373
149.13	0.065	236.1	0.0373
149.17	0.062	236.1	0.0364
149.20	0.063	236	0.0355
149.23	0.059	235.9	0.0355
149.27	0.059	235.9	0.0337
149.30	0.059	235.9	0.0337
149.33	0.062	236	0.0346
149.37	0.059	235.9	0.0337
149.40	0.059	235.9	0.0328
149.43	0.058	235.8	0.0328
149.47	0.056	235.7	0.0328
149.50	0.053	235.6	0.032
149.53	0.053	235.6	0.0302
149.57	0.055	235.7	0.0311
149.60	0.057	235.7	0.0302
149.65	0.054	235.6	0.0293
149.68	0.054	235.6	0.0293
149.70	0.052	235.5	0.0284
149.73	0.052	235.5	0.0275
149.77	0.05	235.5	0.0266
149.80	0.049	235.4	0.0266
149.83	0.049	235.4	0.0257
149.87	0.049	235.4	0.0249
149.90	0.048	235.3	0.0249
149.93	0.047	235.2	0.024
149.97	0.046	235.2	0.0222
150.00	0.044	235.2	0.0222
150.03	0.045	235.2	0.0222
150.07	0.044	235.1	0.0213
150.10	0.044	235.1	0.0204
150.13	0.041	235	0.0186
150.17	0.043	235	0.0186
150.20	0.042	234.9	0.0186
150.23	0.041	234.9	0.0169
150.27	0.039	234.8	0.0169
150.30	0.038	234.7	0.016
150.33	0.038	234.7	0.0151
150.37	0.038	234.7	0.0142

Prova triassiale ciclica SNME01-C3			
ensione di confinamento (kPa)		380	
deviatore ciclico (kPa)		80	
frequenza (hz)		0.00071429	
tempo	cella di carico	u	LVDT
(min)	kN	(kPa)	δ (mm)
150.40	0.035	234.6	0.0124
150.43	0.034	234.5	0.0124
150.47	0.036	234.6	0.0124
150.50	0.036	234.5	0.0124
150.53	0.033	234.4	0.0115
150.57	0.033	234.4	0.0098
150.60	0.03	234.3	0.008
150.63	0.029	234.2	0.0071
150.67	0.032	234.3	0.0071
150.70	0.031	234.2	0.0053
150.73	0.027	234.1	0.0053
150.77	0.027	234.1	0.0036
150.80	0.027	234.1	0.0036
150.83	0.027	234	0.0018
150.87	0.026	234	0.0009
150.90	0.025	233.9	0
150.93	0.024	233.9	-0.0009
150.97	0.023	233.8	-0.0009
151.00	0.021	233.7	-0.0018
151.03	0.021	233.7	-0.0036
151.07	0.022	233.7	-0.0036
151.12	0.02	233.5	-0.0053
151.15	0.02	233.5	-0.0062
151.17	0.019	233.5	-0.0071
151.20	0.018	233.4	-0.008
151.23	0.017	233.3	-0.0098
151.27	0.016	233.3	-0.0107
151.30	0.015	233.2	-0.0107
151.33	0.014	233.1	-0.0115
151.37	0.014	233.1	-0.0133
151.40	0.014	233	-0.0142
151.43	0.012	232.9	-0.016
151.47	0.011	232.8	-0.0169
151.50	0.011	232.8	-0.0178
151.53	0.01	232.7	-0.0178
151.57	0.008	232.6	-0.0186
151.60	0.008	232.6	-0.0204
151.63	0.007	232.6	-0.0213
151.67	0.006	232.5	-0.0231
151.70	0.006	232.4	-0.024
151.73	0.005	232.4	-0.0249
151.77	0.003	232.3	-0.0249
151.80	0.002	232.2	-0.0266
151.83	0.002	232.2	-0.0284
151.87	0.002	232.1	-0.0293
151.90	0.001	232.1	-0.0302
151.93	0	232	-0.032
151.97	-0.002	231.9	-0.0337
152.00	-0.002	231.8	-0.0337
152.03	-0.004	231.7	-0.0346
152.07	-0.004	231.7	-0.0355
152.10	-0.003	231.7	-0.0373
152.13	-0.004	231.6	-0.0382
152.17	-0.006	231.5	-0.0399
152.20	-0.006	231.4	-0.0417
152.23	-0.008	231.3	-0.0417
152.27	-0.008	231.2	-0.0435
152.30	-0.008	231.2	-0.0444

Prova triassiale ciclica SNME01-C3			
pressione di confinamento (kPa)		380	
deviatore ciclico (kPa)		80	
frequenza (hz)		0.00071429	
tempo	cella di carico	u	LVDT
(min)	kN	(kPa)	δ (mm)
152.33	-0.009	231.2	-0.047
152.37	-0.01	231	-0.0488
152.40	-0.013	230.9	-0.0515
152.43	-0.011	230.9	-0.0524
152.47	-0.012	230.8	-0.0524
152.50	-0.014	230.6	-0.0541
152.55	-0.015	230.5	-0.0595
152.58	-0.015	230.5	-0.0595
152.60	-0.017	230.3	-0.0621
152.63	-0.017	230.3	-0.0648
152.67	-0.017	230.3	-0.0675
152.70	-0.018	230.1	-0.0719
152.73	-0.019	230	-0.0772
152.77	-0.019	229.9	-0.0826
152.80	-0.021	229.8	-0.0826
152.83	-0.022	229.6	-0.0888
152.87	-0.022	229.6	-0.0968
152.90	-0.023	229.5	-0.1065
152.93	-0.023	229.4	-0.1198
152.97	-0.024	229.2	-0.142
153.00	-0.024	228.9	-0.1651
153.03	-0.027	228.6	-0.1651
153.07	-0.028	228.4	-0.1811
153.10	-0.028	228.4	-0.1891
153.13	-0.028	228.3	-0.1944
153.17	-0.029	228.1	-0.1988
153.20	-0.03	228	-0.2006
153.23	-0.03	228	-0.2024
153.27	-0.031	227.7	-0.2024
153.30	-0.032	227.6	-0.2104
153.33	-0.032	227.6	-0.2148
153.37	-0.033	227.5	-0.2192
153.40	-0.034	227.3	-0.2228
153.43	-0.036	227.2	-0.2263
153.47	-0.035	227.1	-0.2281
153.50	-0.037	227	-0.2281
153.53	-0.037	226.9	-0.2317
153.57	-0.037	226.9	-0.2334
153.60	-0.038	226.8	-0.237
153.63	-0.039	226.6	-0.2397
153.67	-0.04	226.5	-0.2423
153.70	-0.04	226.4	-0.245
153.73	-0.041	226.3	-0.245
153.77	-0.043	226.2	-0.2468
153.80	-0.043	226.2	-0.2494
153.83	-0.043	226.1	-0.2521
153.87	-0.044	226	-0.2539
153.90	-0.045	225.8	-0.2556
153.93	-0.046	225.7	-0.2583
153.97	-0.046	225.6	-0.2583
154.02	-0.047	225.6	-0.2619
154.05	-0.048	225.5	-0.2636
154.07	-0.048	225.4	-0.2636
154.10	-0.05	225.2	-0.2654
154.13	-0.05	225.2	-0.2681
154.17	-0.049	225.2	-0.269
154.20	-0.05	225.1	-0.2707
154.23	-0.052	225	-0.2725

Prova triassiale ciclica SNME01-C3			
pressione di confinamento (kPa)		380	
deviatore ciclico (kPa)		80	
frequenza (hz)		0.00071429	
tempo	cella di carico	u	LVDT
(min)	kN	(kPa)	δ (mm)
154.27	-0.052	224.9	-0.2743
154.30	-0.052	224.8	-0.2743
154.33	-0.054	224.6	-0.2761
154.37	-0.054	224.6	-0.2787
154.40	-0.054	224.5	-0.2796
154.43	-0.055	224.4	-0.2814
154.47	-0.056	224.3	-0.284
154.50	-0.056	224.3	-0.2858
154.53	-0.056	224.2	-0.2858
154.57	-0.058	224	-0.2876
154.60	-0.058	224	-0.2894
154.63	-0.058	224	-0.2903
154.67	-0.06	223.8	-0.292
154.70	-0.06	223.8	-0.2938
154.73	-0.059	223.7	-0.2947
154.77	-0.06	223.6	-0.2947
154.80	-0.062	223.5	-0.2956
154.83	-0.062	223.5	-0.2974
154.87	-0.062	223.4	-0.2982
154.90	-0.062	223.3	-0.2991
154.93	-0.064	223.2	-0.3009
154.97	-0.064	223.2	-0.3018
155.00	-0.064	223.1	-0.3018
155.03	-0.065	223	-0.3027
155.07	-0.065	223	-0.3036
155.10	-0.065	222.9	-0.3053
155.13	-0.066	222.8	-0.3062
155.17	-0.067	222.7	-0.3071
155.20	-0.067	222.7	-0.308
155.23	-0.068	222.6	-0.308
155.27	-0.068	222.5	-0.3098
155.30	-0.068	222.5	-0.3107
155.33	-0.069	222.4	-0.3116
155.37	-0.069	222.3	-0.3124
155.40	-0.071	222.2	-0.3142
155.45	-0.07	222.2	-0.3151
155.48	-0.07	222.1	-0.316
155.50	-0.072	222	-0.3169
155.53	-0.071	222	-0.3178
155.57	-0.071	221.9	-0.3178
155.60	-0.073	221.8	-0.3187
155.63	-0.073	221.8	-0.3196
155.67	-0.073	221.7	-0.3204
155.70	-0.073	221.7	-0.3213
155.73	-0.074	221.6	-0.3231
155.77	-0.075	221.5	-0.3231
155.80	-0.074	221.5	-0.3231
155.83	-0.076	221.4	-0.324
155.87	-0.076	221.4	-0.3249
155.90	-0.075	221.3	-0.3258
155.93	-0.076	221.2	-0.3267
155.97	-0.077	221.2	-0.3267
156.00	-0.077	221.1	-0.3275
156.03	-0.077	221	-0.3275
156.07	-0.077	221	-0.3284
156.10	-0.077	221	-0.3293
156.13	-0.078	220.9	-0.3302
156.17	-0.078	220.8	-0.3302

Prova triassiale ciclica SNME01-C3			
pressione di confinamento (kPa)		380	
deviatore ciclico (kPa)		80	
frequenza (hz)		0.00071429	
tempo	cella di carico	u	LVDT
(min)	kN	(kPa)	δ (mm)
156.20	-0.078	220.8	-0.3311
156.23	-0.079	220.7	-0.332
156.27	-0.079	220.7	-0.332
156.30	-0.08	220.6	-0.332
156.33	-0.08	220.6	-0.3329
156.37	-0.079	220.6	-0.3338
156.40	-0.08	220.5	-0.3338
156.43	-0.081	220.4	-0.3346
156.47	-0.081	220.4	-0.3355
156.50	-0.081	220.3	-0.3355
156.53	-0.082	220.3	-0.3355
156.57	-0.082	220.3	-0.3364
156.60	-0.081	220.2	-0.3364
156.63	-0.081	220.2	-0.3373
156.67	-0.082	220.1	-0.3373
156.70	-0.082	220.1	-0.3382
156.73	-0.082	220.1	-0.3382
156.77	-0.083	220	-0.3382
156.80	-0.083	220	-0.3391
156.83	-0.083	220	-0.3391
156.87	-0.083	219.9	-0.34
156.92	-0.083	219.9	-0.34
156.95	-0.083	219.8	-0.3409
156.97	-0.083	219.8	-0.3409
157.00	-0.083	219.8	-0.3409
157.03	-0.083	219.7	-0.3417
157.07	-0.084	219.7	-0.3426
157.10	-0.084	219.6	-0.3426
157.13	-0.084	219.6	-0.3426
157.17	-0.084	219.6	-0.3426
157.20	-0.084	219.6	-0.3426
157.23	-0.084	219.5	-0.3435
157.27	-0.084	219.5	-0.3435
157.30	-0.084	219.5	-0.3435
157.33	-0.084	219.5	-0.3435
157.37	-0.084	219.5	-0.3444
157.40	-0.085	219.4	-0.3444
157.43	-0.084	219.4	-0.3444
157.47	-0.084	219.4	-0.3453
157.50	-0.084	219.3	-0.3453
157.53	-0.084	219.3	-0.3453
157.57	-0.084	219.3	-0.3453
157.60	-0.084	219.3	-0.3453
157.63	-0.084	219.3	-0.3462
157.67	-0.084	219.2	-0.3462
157.70	-0.084	219.2	-0.3462
157.73	-0.084	219.2	-0.3462
157.77	-0.084	219.2	-0.3462
157.80	-0.084	219.1	-0.3462
157.83	-0.084	219.1	-0.3471
157.87	-0.084	219.1	-0.3471
157.90	-0.084	219.1	-0.3471
157.93	-0.083	219.1	-0.3471
157.97	-0.084	219.1	-0.3471
158.00	-0.084	219.1	-0.3471
158.03	-0.083	219.1	-0.3471
158.07	-0.083	219.1	-0.3471
158.10	-0.083	219.1	-0.3471

Prova triassiale ciclica SNME01-C3			
pressione di confinamento (kPa)		380	
deviatore ciclico (kPa)		80	
frequenza (hz)		0.00071429	
tempo	cella di carico	u	LVDT
(min)	kN	(kPa)	δ (mm)
158.13	-0.083	219.1	-0.3471
158.17	-0.083	219.1	-0.348
158.20	-0.083	219	-0.348
158.23	-0.082	219	-0.348
158.27	-0.082	219	-0.348
158.30	-0.082	219	-0.348
158.33	-0.082	219	-0.348
158.38	-0.082	219	-0.348
158.40	-0.082	219	-0.348
158.43	-0.082	219	-0.348
158.47	-0.081	219	-0.348
158.50	-0.081	219	-0.348
158.53	-0.081	219	-0.348
158.57	-0.081	219	-0.348
158.60	-0.08	219	-0.348
158.63	-0.081	219	-0.348
158.67	-0.081	219	-0.348
158.70	-0.08	219	-0.3471
158.73	-0.079	219	-0.3471
158.77	-0.079	219	-0.3471
158.80	-0.079	219	-0.3471
158.83	-0.078	219	-0.3471
158.87	-0.078	219	-0.3471
158.90	-0.078	219	-0.3471
158.93	-0.078	219	-0.3471
158.97	-0.078	219	-0.3471
159.00	-0.077	219.1	-0.3471
159.03	-0.077	219.1	-0.3462
159.07	-0.076	219.1	-0.3462
159.10	-0.076	219.1	-0.3462
159.13	-0.076	219.1	-0.3462
159.17	-0.076	219.1	-0.3462
159.20	-0.075	219.1	-0.3462
159.23	-0.074	219.1	-0.3453
159.27	-0.075	219.1	-0.3462
159.30	-0.074	219.2	-0.3462
159.33	-0.074	219.2	-0.3453
159.37	-0.074	219.2	-0.3453
159.40	-0.074	219.2	-0.3453
159.43	-0.073	219.2	-0.3453
159.47	-0.072	219.3	-0.3444
159.50	-0.072	219.3	-0.3444
159.53	-0.072	219.3	-0.3444
159.57	-0.071	219.3	-0.3444
159.60	-0.071	219.3	-0.3435
159.63	-0.07	219.3	-0.3435
159.67	-0.07	219.4	-0.3435
159.70	-0.069	219.4	-0.3435
159.73	-0.069	219.4	-0.3426
159.77	-0.068	219.5	-0.3426
159.82	-0.068	219.5	-0.3426
159.85	-0.067	219.5	-0.3426
159.87	-0.067	219.5	-0.3426
159.90	-0.067	219.5	-0.3417
159.93	-0.067	219.6	-0.3417
159.97	-0.066	219.6	-0.3417
160.00	-0.065	219.6	-0.3409
160.03	-0.064	219.7	-0.3409

Prova triassiale ciclica SNME01-C3			
pressione di confinamento (kPa)		380	
deviatore ciclico (kPa)		80	
frequenza (hz)		0.00071429	
tempo	cella di carico	u	LVDT
(min)	kN	(kPa)	δ (mm)
160.07	-0.064	219.7	-0.3409
160.10	-0.063	219.8	-0.3409
160.13	-0.063	219.8	-0.34
160.17	-0.063	219.8	-0.34
160.20	-0.063	219.8	-0.3391
160.23	-0.061	219.9	-0.3391
160.27	-0.061	219.9	-0.3382
160.30	-0.061	219.9	-0.3382
160.33	-0.059	220	-0.3382
160.37	-0.059	220	-0.3382
160.40	-0.059	220	-0.3373
160.43	-0.059	220.1	-0.3373
160.47	-0.057	220.1	-0.3364
160.50	-0.057	220.2	-0.3364
160.53	-0.057	220.2	-0.3355
160.57	-0.056	220.3	-0.3355
160.60	-0.054	220.3	-0.3355
160.63	-0.054	220.3	-0.3346
160.67	-0.055	220.3	-0.3346
160.70	-0.053	220.4	-0.3338
160.73	-0.053	220.4	-0.3338
160.77	-0.052	220.5	-0.3329
160.80	-0.05	220.6	-0.3329
160.83	-0.051	220.6	-0.332
160.87	-0.051	220.6	-0.332
160.90	-0.05	220.7	-0.3311
160.93	-0.048	220.8	-0.3302
160.97	-0.048	220.8	-0.3302
161.00	-0.048	220.9	-0.3293
161.03	-0.046	221	-0.3293
161.07	-0.046	221	-0.3284
161.10	-0.046	221	-0.3275
161.13	-0.046	221	-0.3275
161.17	-0.045	221.1	-0.3267
161.20	-0.044	221.2	-0.3258
161.23	-0.043	221.3	-0.3249
161.28	-0.042	221.4	-0.324
161.32	-0.042	221.4	-0.3231
161.33	-0.041	221.5	-0.3222
161.37	-0.04	221.6	-0.3222
161.40	-0.039	221.6	-0.3213
161.43	-0.039	221.6	-0.3213
161.47	-0.039	221.7	-0.3196
161.50	-0.038	221.8	-0.3187
161.53	-0.037	221.9	-0.3178
161.57	-0.036	221.9	-0.3169
161.60	-0.035	222	-0.3169
161.63	-0.035	222	-0.316
161.67	-0.035	222	-0.3151
161.70	-0.034	222.1	-0.3142
161.73	-0.032	222.2	-0.3124
161.77	-0.032	222.3	-0.3116
161.80	-0.031	222.4	-0.3107
161.83	-0.03	222.5	-0.3107
161.87	-0.03	222.5	-0.3089
161.90	-0.03	222.6	-0.308
161.93	-0.028	222.7	-0.3062
161.97	-0.027	222.8	-0.3053

Prova triassiale ciclica SNME01-C3			
pressione di confinamento (kPa)		380	
deviatore ciclico (kPa)		80	
frequenza (hz)		0.00071429	
tempo	cella di carico	u	LVDT
(min)	kN	(kPa)	δ (mm)
162.00	-0.027	222.8	-0.3045
162.03	-0.026	222.9	-0.3027
162.07	-0.025	223	-0.3027
162.10	-0.024	223	-0.3018
162.13	-0.024	223.1	-0.3
162.17	-0.024	223.2	-0.2982
162.20	-0.022	223.3	-0.2965
162.23	-0.021	223.4	-0.2947
162.27	-0.021	223.5	-0.2929
162.30	-0.02	223.5	-0.2929
162.33	-0.018	223.5	-0.2911
162.37	-0.018	223.7	-0.2885
162.40	-0.018	223.8	-0.2867
162.43	-0.016	223.9	-0.2823
162.47	-0.016	224	-0.2805
162.50	-0.016	224.1	-0.2778
162.53	-0.014	224.3	-0.2778
162.57	-0.013	224.3	-0.2752
162.60	-0.013	224.4	-0.2725
162.63	-0.012	224.5	-0.269
162.67	-0.011	224.6	-0.2663
162.72	-0.011	224.7	-0.2636
162.75	-0.011	224.8	-0.261
162.77	-0.008	225	-0.2574
162.80	-0.009	225	-0.2548
162.83	-0.007	225.2	-0.2512
162.87	-0.006	225.3	-0.2512
162.90	-0.005	225.3	-0.2485
162.93	-0.005	225.4	-0.245
162.97	-0.005	225.5	-0.2414
163.00	-0.004	225.6	-0.237
163.03	-0.002	225.7	-0.2334
163.07	-0.002	225.8	-0.229
163.10	0	225.9	-0.229
163.13	0.001	225.9	-0.2246
163.17	0.001	226.1	-0.2192
163.20	0.001	226.2	-0.2157
163.23	0.002	226.3	-0.2104
163.27	0.003	226.4	-0.2059
163.30	0.004	226.6	-0.1997
163.33	0.005	226.8	-0.1997
163.37	0.007	226.8	-0.1944
163.40	0.007	226.9	-0.1891
163.43	0.006	227	-0.1846
163.47	0.008	227.1	-0.1811
163.50	0.009	227.2	-0.1775
163.53	0.009	227.4	-0.174
163.57	0.011	227.5	-0.174
163.60	0.012	227.5	-0.1713
163.63	0.012	227.6	-0.1687
163.67	0.012	227.6	-0.166
163.70	0.014	227.8	-0.1616
163.73	0.015	227.9	-0.1589
163.77	0.015	228	-0.1562
163.80	0.016	228.1	-0.1562
163.83	0.017	228.1	-0.15
163.87	0.017	228.2	-0.1429
163.90	0.018	228.4	-0.1358

Prova triassiale ciclica SNME01-C3			
pressione di confinamento (kPa)		380	
deviatore ciclico (kPa)		80	
frequenza (hz)		0.00071429	
tempo	cella di carico	u	LVDT
(min)	kN	(kPa)	δ (mm)
163.93	0.02	228.5	-0.1305
163.97	0.02	228.6	-0.1252
164.00	0.02	228.7	-0.1198
164.03	0.023	229	-0.1198
164.07	0.023	229	-0.1145
164.10	0.023	229	-0.1101
164.13	0.023	229.1	-0.1065
164.18	0.025	229.3	-0.1012
164.22	0.025	229.3	-0.0968
164.23	0.026	229.5	-0.0932
164.27	0.028	229.6	-0.0879
164.30	0.028	229.7	-0.0843
164.33	0.029	229.8	-0.0808
164.37	0.029	229.9	-0.0808
164.40	0.031	229.9	-0.0763
164.43	0.031	230	-0.0719
164.47	0.032	230.2	-0.0683
164.50	0.033	230.3	-0.0639
164.53	0.034	230.4	-0.0595
164.57	0.035	230.5	-0.055
164.60	0.035	230.6	-0.055
164.63	0.036	230.6	-0.0524
164.67	0.036	230.7	-0.0488
164.70	0.037	230.7	-0.0462
164.73	0.039	230.8	-0.0444
164.77	0.038	230.8	-0.0426
164.80	0.04	230.9	-0.0408
164.83	0.042	231	-0.0408
164.87	0.043	231	-0.0391
164.90	0.043	231.1	-0.0373
164.93	0.04	231	-0.0373
164.97	0.043	231.2	-0.0355
165.00	0.043	231.2	-0.0337
165.03	0.045	231.3	-0.032
165.07	0.046	231.4	-0.032
165.10	0.047	231.4	-0.0311
165.13	0.047	231.5	-0.0293
165.17	0.046	231.6	-0.0284
165.20	0.049	231.7	-0.0266
165.23	0.049	231.7	-0.0257
165.27	0.05	231.8	-0.0249
165.30	0.052	231.9	-0.0249
165.33	0.051	231.9	-0.0231
165.37	0.051	231.9	-0.0222
165.40	0.052	232	-0.0204
165.43	0.054	232.1	-0.0195
165.47	0.054	232.2	-0.0186
165.50	0.055	232.3	-0.0178
165.53	0.056	232.3	-0.0178
165.57	0.056	232.3	-0.016
165.62	0.057	232.5	-0.0142
165.65	0.057	232.5	-0.0142
165.67	0.059	232.5	-0.0133
165.70	0.059	232.6	-0.0115
165.73	0.059	232.7	-0.0107
165.77	0.06	232.8	-0.0098
165.80	0.061	232.8	-0.0089
165.83	0.061	232.9	-0.0071

Prova triassiale ciclica SNME01-C3			
pressione di confinamento (kPa)		380	
deviatore ciclico (kPa)		80	
frequenza (hz)		0.00071429	
tempo	cella di carico	u	LVDT
(min)	kN	(kPa)	δ (mm)
165.87	0.062	233	-0.0071
165.90	0.063	233	-0.0062
165.93	0.063	233	-0.0053
165.97	0.063	233.1	-0.0044
166.00	0.065	233.2	-0.0036
166.03	0.065	233.3	-0.0027
166.07	0.066	233.4	-0.0009
166.10	0.066	233.4	-0.0009
166.13	0.07	233.4	0
166.17	0.07	233.6	0.0027
166.20	0.066	233.5	0.0018
166.23	0.068	233.6	0.0027
166.27	0.069	233.7	0.0036
166.30	0.07	233.8	0.0044
166.33	0.071	233.8	0.0044
166.37	0.071	233.8	0.0053
166.40	0.071	233.9	0.0062
166.43	0.072	234	0.0089
166.47	0.075	234.2	0.0098
166.50	0.073	234.2	0.0107
166.53	0.074	234.2	0.0107
166.57	0.072	234.2	0.0107
166.60	0.074	234.2	0.0107
166.63	0.074	234.3	0.0124
166.67	0.075	234.3	0.0133
166.70	0.076	234.4	0.0142
166.73	0.076	234.5	0.0151
166.77	0.078	234.6	0.016
166.80	0.078	234.7	0.016
166.83	0.078	234.7	0.0169
166.87	0.078	234.7	0.0178
166.90	0.079	234.8	0.0186
166.93	0.08	234.9	0.0186
166.97	0.079	234.9	0.0195
167.00	0.083	235	0.0213
167.03	0.083	235.1	0.0213
167.08	0.082	235.1	0.0231
167.12	0.08	235.1	0.0231
167.13	0.081	235.2	0.0231
167.17	0.083	235.2	0.024
167.20	0.083	235.3	0.0249
167.23	0.083	235.3	0.0257
167.27	0.085	235.4	0.0275
167.30	0.086	235.5	0.0275
167.33	0.086	235.5	0.0284
167.37	0.085	235.6	0.0284
167.40	0.085	235.6	0.0284
167.43	0.085	235.6	0.0293
167.47	0.086	235.7	0.0302
167.50	0.087	235.7	0.0311
167.53	0.087	235.8	0.0311
167.57	0.087	235.8	0.032
167.60	0.088	235.9	0.032
167.63	0.088	235.9	0.0328
167.67	0.088	236	0.0328
167.70	0.089	236	0.0337
167.73	0.089	236.1	0.0346
167.77	0.089	236.1	0.0346

Prova triassiale ciclica SNME01-C3			
ensione di confinamento (kPa)		380	
deviatore ciclico (kPa)		80	
frequenza (hz)		0.00071429	
tempo	cella di carico	u	LVDT
(min)	kN	(kPa)	δ (mm)
167.80	0.086	236.1	0.0346
167.83	0.091	236.2	0.0346
167.87	0.092	236.2	0.0364
167.90	0.092	236.3	0.0373
167.93	0.091	236.3	0.0373
167.97	0.091	236.4	0.0373
168.00	0.091	236.4	0.0382
168.03	0.091	236.5	0.0382
168.07	0.092	236.5	0.0382
168.10	0.092	236.5	0.0391
168.13	0.092	236.6	0.0391
168.17	0.093	236.6	0.0399
168.20	0.093	236.7	0.0399
168.23	0.093	236.7	0.0408
168.27	0.093	236.7	0.0408
168.30	0.093	236.8	0.0408
168.33	0.093	236.8	0.0417
168.37	0.093	236.8	0.0417
168.40	0.094	236.9	0.0426
168.43	0.094	236.9	0.0426
168.47	0.094	237	0.0435
168.50	0.094	237	0.0435
168.55	0.094	237	0.0435
168.58	0.094	237.1	0.0444
168.60	0.095	237.1	0.0444
168.63	0.095	237.2	0.0444
168.67	0.095	237.2	0.0444
168.70	0.095	237.2	0.0453
168.73	0.096	237.2	0.0453
168.77	0.095	237.3	0.0453
168.80	0.095	237.2	0.0453
168.83	0.094	237.3	0.0453
168.87	0.098	237.5	0.0453
168.90	0.094	237.5	0.0462
168.93	0.094	237.4	0.0462
168.97	0.097	237.5	0.047
169.00	0.097	237.6	0.047
169.03	0.096	237.6	0.047
169.07	0.096	237.6	0.047
169.10	0.095	237.6	0.047
169.13	0.096	237.6	0.047
169.17	0.096	237.6	0.0479
169.20	0.096	237.7	0.0479
169.23	0.096	237.7	0.0479
169.27	0.096	237.7	0.0479
169.30	0.096	237.7	0.0479
169.33	0.096	237.8	0.0479
169.37	0.096	237.8	0.0479
169.40	0.096	237.8	0.0479
169.43	0.096	237.8	0.0479
169.47	0.095	237.8	0.0479
169.50	0.096	237.9	0.0488
169.53	0.095	237.9	0.0488
169.57	0.095	237.9	0.0488
169.60	0.095	237.9	0.0488
169.63	0.095	237.9	0.0488
169.67	0.095	237.9	0.0488
169.70	0.092	237.9	0.0479

Prova triassiale ciclica SNME01-C3			
pressione di confinamento (kPa)		380	
deviatore ciclico (kPa)		80	
frequenza (hz)		0.00071429	
tempo	cella di carico	u	LVDT
(min)	kN	(kPa)	δ (mm)
169.73	0.098	238.1	0.0497
169.77	0.095	238	0.0488
169.80	0.093	237.9	0.0488
169.83	0.095	237.9	0.0479
169.87	0.095	238	0.0488
169.90	0.094	238	0.0488
169.93	0.094	238	0.0488
169.98	0.094	238.1	0.0488
170.02	0.094	238.1	0.0488
170.03	0.094	238.1	0.0488
170.07	0.091	238	0.0488
170.10	0.095	238.2	0.0497
170.13	0.094	238.1	0.0497
170.17	0.093	238.1	0.0488
170.20	0.093	238.1	0.0488
170.23	0.093	238.2	0.0479
170.27	0.092	238.1	0.0488
170.30	0.092	238.2	0.0479
170.33	0.09	238.1	0.0479
170.37	0.092	238.2	0.0479
170.40	0.092	238.2	0.0488
170.43	0.092	238.2	0.0488
170.47	0.091	238.2	0.0488
170.50	0.088	238.1	0.0479
170.53	0.091	238.2	0.0488
170.57	0.091	238.2	0.0479
170.60	0.089	238.2	0.0479
170.63	0.089	238.2	0.0479
170.67	0.089	238.2	0.0479
170.70	0.085	238.1	0.047
170.73	0.091	238.3	0.0488
170.77	0.089	238.2	0.0479
170.80	0.087	238.2	0.047
170.83	0.087	238.2	0.047
170.87	0.087	238.2	0.047
170.90	0.087	238.2	0.047
170.93	0.087	238.2	0.047
170.97	0.086	238.2	0.047
171.00	0.086	238.2	0.047
171.03	0.085	238.2	0.0462
171.07	0.084	238.2	0.0462
171.10	0.084	238.2	0.0462
171.13	0.084	238.2	0.0462
171.17	0.084	238.2	0.0462
171.20	0.083	238.1	0.0462
171.23	0.082	238.1	0.0462
171.27	0.082	238.1	0.0453
171.30	0.082	238.1	0.0453
171.33	0.082	238.1	0.0453
171.37	0.082	238.1	0.0453
171.40	0.081	238.1	0.0453
171.45	0.08	238	0.0444
171.48	0.08	238.1	0.0444
171.50	0.079	238	0.0444
171.53	0.079	238	0.0444
171.57	0.078	238	0.0435
171.60	0.078	238	0.0435
171.63	0.077	238	0.0435

Prova triassiale ciclica SNME01-C3			
pressione di confinamento (kPa)		380	
deviatore ciclico (kPa)		80	
frequenza (hz)		0.00071429	
tempo	cella di carico	u	LVDT
(min)	kN	(kPa)	δ (mm)
171.67	0.076	238	0.0435
171.70	0.076	237.9	0.0426
171.73	0.076	237.9	0.0426
171.77	0.075	237.9	0.0426
171.80	0.072	237.8	0.0417
171.83	0.076	237.9	0.0426
171.87	0.074	237.9	0.0426
171.90	0.073	237.9	0.0417
171.93	0.073	237.9	0.0408
171.97	0.071	237.8	0.0408
172.00	0.072	237.8	0.0408
172.03	0.071	237.8	0.0399
172.07	0.068	237.7	0.0391
172.10	0.071	237.7	0.0391
172.13	0.067	237.7	0.0391
172.17	0.067	237.6	0.0382
172.20	0.068	237.7	0.0382
172.23	0.07	237.7	0.0391
172.27	0.067	237.6	0.0382
172.30	0.066	237.6	0.0373
172.33	0.065	237.5	0.0373
172.37	0.065	237.5	0.0364
172.40	0.065	237.5	0.0364
172.43	0.064	237.5	0.0355
172.47	0.063	237.4	0.0355
172.50	0.062	237.4	0.0346
172.53	0.062	237.4	0.0346
172.57	0.061	237.4	0.0346
172.60	0.06	237.4	0.0337
172.63	0.06	237.3	0.0328
172.67	0.06	237.2	0.0328
172.70	0.059	237.2	0.032
172.73	0.058	237.2	0.0311
172.77	0.057	237.1	0.0311
172.80	0.057	237.1	0.0311
172.83	0.054	237.1	0.0302
172.88	0.056	237.1	0.0293
172.92	0.056	237	0.0293
172.93	0.052	236.9	0.0284
172.97	0.052	236.9	0.0275
173.00	0.052	236.9	0.0266
173.03	0.052	236.8	0.0266
173.07	0.051	236.8	0.0257
173.10	0.051	236.8	0.0249
173.13	0.049	236.7	0.0249
173.17	0.049	236.7	0.024
173.20	0.049	236.7	0.024
173.23	0.048	236.6	0.0222
173.27	0.047	236.6	0.0222
173.30	0.046	236.5	0.0213
173.33	0.045	236.5	0.0204
173.37	0.045	236.4	0.0204
173.40	0.044	236.4	0.0195
173.43	0.044	236.4	0.0186
173.47	0.043	236.3	0.0178
173.50	0.041	236.2	0.0169
173.53	0.041	236.2	0.0169
173.57	0.04	236.2	0.0151

Prova triassiale ciclica SNME01-C3			
ensione di confinamento (kPa)		380	
deviatore ciclico (kPa)		80	
frequenza (hz)		0.00071429	
tempo	cella di carico	u	LVDT
(min)	kN	(kPa)	δ (mm)
173.60	0.039	236.1	0.0151
173.63	0.038	236.1	0.0142
173.67	0.038	236.1	0.0133
173.70	0.038	236	0.0133
173.73	0.037	235.9	0.0124
173.77	0.036	235.9	0.0107
173.80	0.035	235.8	0.0098
173.83	0.034	235.8	0.0098
173.87	0.033	235.7	0.0089
173.90	0.033	235.7	0.008
173.93	0.033	235.7	0.0071
173.97	0.031	235.6	0.0062
174.00	0.03	235.5	0.0053
174.03	0.03	235.5	0.0044
174.07	0.029	235.4	0.0044
174.10	0.027	235.3	0.0036
174.13	0.027	235.3	0.0018
174.17	0.027	235.3	0.0009
174.20	0.026	235.2	0
174.23	0.024	235.1	-0.0009
174.27	0.024	235.1	-0.0018
174.30	0.023	235	-0.0018
174.35	0.023	235	-0.0044
174.38	0.021	234.9	-0.0053
174.40	0.021	234.8	-0.0053
174.43	0.02	234.8	-0.0062
174.47	0.02	234.8	-0.008
174.50	0.018	234.7	-0.0089
174.53	0.018	234.6	-0.0098
174.57	0.017	234.6	-0.0107
174.60	0.017	234.5	-0.0115
174.63	0.015	234.4	-0.0115
174.67	0.014	234.4	-0.0133
174.70	0.014	234.4	-0.0142
174.73	0.014	234.3	-0.0151
174.77	0.012	234.2	-0.0169
174.80	0.011	234.2	-0.0186
174.83	0.01	234.1	-0.0195
174.87	0.01	234	-0.0195
174.90	0.008	233.9	-0.0204
174.93	0.008	233.9	-0.0213
174.97	0.008	233.9	-0.0231
175.00	0.006	233.8	-0.024
175.03	0.005	233.7	-0.0257
175.07	0.005	233.7	-0.0266
175.10	0.004	233.6	-0.0266
175.13	0.002	233.5	-0.0275
175.17	0.002	233.5	-0.0293
175.20	0.002	233.4	-0.0302
175.23	0.001	233.3	-0.0311
175.27	0	233.3	-0.0328
175.30	-0.001	233.2	-0.0337
175.33	-0.002	233.1	-0.0337
175.37	-0.003	233	-0.0355
175.40	-0.003	233	-0.0373
175.43	-0.004	232.9	-0.0382
175.47	-0.004	232.8	-0.0391
175.50	-0.007	232.7	-0.0408

Prova triassiale ciclica SNME01-C3			
pressione di confinamento (kPa)		380	
deviatore ciclico (kPa)		80	
frequenza (hz)		0.00071429	
tempo	cella di carico	u	LVDT
(min)	kN	(kPa)	δ (mm)
175.53	-0.006	232.7	-0.0417
175.57	-0.007	232.6	-0.0417
175.60	-0.009	232.5	-0.0426
175.63	-0.009	232.5	-0.0444
175.67	-0.01	232.4	-0.047
175.70	-0.01	232.3	-0.0488
175.73	-0.011	232.2	-0.0506
175.77	-0.012	232.1	-0.0541
175.82	-0.014	231.9	-0.0568
175.83	-0.013	231.9	-0.0586
175.87	-0.014	231.8	-0.0612
175.90	-0.016	231.7	-0.0612
175.93	-0.017	231.6	-0.063
175.97	-0.017	231.6	-0.0648
176.00	-0.017	231.5	-0.0666
176.03	-0.019	231.3	-0.0692
176.07	-0.018	231.3	-0.0746
176.10	-0.02	231.1	-0.0817
176.13	-0.022	230.9	-0.0817
176.17	-0.022	230.8	-0.0879
176.20	-0.022	230.8	-0.0932
176.23	-0.022	230.7	-0.0994
176.27	-0.023	230.6	-0.1074
176.30	-0.025	230.4	-0.1163
176.33	-0.025	230.3	-0.1269
176.37	-0.026	230.1	-0.1269
176.40	-0.027	229.9	-0.142
176.43	-0.027	229.9	-0.1589
176.47	-0.028	229.7	-0.1704
176.50	-0.029	229.5	-0.1731
176.53	-0.03	229.3	-0.1864
176.57	-0.03	229.2	-0.1917
176.60	-0.031	229	-0.1917
176.63	-0.033	228.8	-0.1971
176.67	-0.033	228.8	-0.2015
176.70	-0.033	228.7	-0.2042
176.73	-0.034	228.6	-0.2086
176.77	-0.035	228.5	-0.2121
176.80	-0.036	228.3	-0.2148
176.83	-0.037	228.2	-0.2148
176.87	-0.038	228	-0.2184
176.90	-0.038	228	-0.221
176.93	-0.038	228	-0.2228
176.97	-0.039	227.8	-0.2263
177.00	-0.04	227.7	-0.229
177.03	-0.04	227.6	-0.2308
177.07	-0.041	227.5	-0.2308
177.10	-0.042	227.4	-0.2343
177.13	-0.042	227.4	-0.2361
177.17	-0.043	227.2	-0.2388
177.20	-0.044	227.2	-0.2406
177.25	-0.045	227	-0.2432
177.28	-0.045	226.9	-0.245
177.30	-0.046	226.9	-0.2468
177.33	-0.046	226.8	-0.2485
177.37	-0.047	226.6	-0.2512
177.40	-0.048	226.5	-0.2512
177.43	-0.05	226.4	-0.253

Prova triassiale ciclica SNME01-C3			
pressione di confinamento (kPa)		380	
deviatore ciclico (kPa)		80	
frequenza (hz)		0.00071429	
tempo	cella di carico	u	LVDT
(min)	kN	(kPa)	δ (mm)
177.47	-0.05	226.4	-0.2556
177.50	-0.05	226.3	-0.2565
177.53	-0.05	226.2	-0.2583
177.57	-0.051	226.1	-0.2601
177.60	-0.052	226	-0.2619
177.63	-0.053	225.9	-0.2619
177.67	-0.053	225.8	-0.2636
177.70	-0.053	225.8	-0.2654
177.73	-0.054	225.7	-0.2672
177.77	-0.055	225.6	-0.2681
177.80	-0.056	225.5	-0.2698
177.83	-0.056	225.5	-0.2716
177.87	-0.057	225.4	-0.2716
177.90	-0.057	225.3	-0.2725
177.93	-0.057	225.3	-0.2743
177.97	-0.058	225.2	-0.2752
178.00	-0.059	225.1	-0.2761
178.03	-0.06	225	-0.2778
178.07	-0.06	224.9	-0.2796
178.10	-0.061	224.8	-0.2796
178.13	-0.062	224.6	-0.2805
178.17	-0.062	224.6	-0.2823
178.20	-0.061	224.6	-0.2832
178.23	-0.062	224.5	-0.284
178.27	-0.063	224.4	-0.2867
178.30	-0.063	224.3	-0.2876
178.33	-0.064	224.2	-0.2876
178.37	-0.066	224.1	-0.2894
178.40	-0.066	224.1	-0.2903
178.43	-0.065	224.1	-0.2903
178.47	-0.066	224	-0.292
178.50	-0.067	223.9	-0.2929
178.53	-0.068	223.8	-0.2938
178.57	-0.068	223.7	-0.2938
178.60	-0.068	223.7	-0.2947
178.63	-0.068	223.7	-0.2956
178.67	-0.069	223.6	-0.2974
178.72	-0.07	223.4	-0.2982
178.75	-0.07	223.4	-0.2991
178.77	-0.07	223.4	-0.2991
178.80	-0.071	223.3	-0.3
178.83	-0.071	223.2	-0.3009
178.87	-0.071	223.2	-0.3018
178.90	-0.072	223.1	-0.3018
178.93	-0.073	223	-0.3027
178.97	-0.073	223	-0.3036
179.00	-0.073	222.9	-0.3045
179.03	-0.074	222.8	-0.3053
179.07	-0.074	222.8	-0.3062
179.10	-0.074	222.7	-0.3071
179.13	-0.075	222.6	-0.3071
179.17	-0.075	222.6	-0.308
179.20	-0.075	222.6	-0.308
179.23	-0.076	222.5	-0.3089
179.27	-0.076	222.5	-0.3098
179.30	-0.076	222.4	-0.3107
179.33	-0.077	222.3	-0.3107
179.37	-0.078	222.2	-0.3107

Prova triassiale ciclica SNME01-C3			
pressione di confinamento (kPa)		380	
deviatore ciclico (kPa)		80	
frequenza (hz)		0.00071429	
tempo	cella di carico	u	LVDT
(min)	kN	(kPa)	δ (mm)
179.40	-0.077	222.2	-0.3116
179.43	-0.077	222.2	-0.3124
179.47	-0.078	222.1	-0.3133
179.50	-0.079	222	-0.3133
179.53	-0.078	222	-0.3142
179.57	-0.079	222	-0.3142
179.60	-0.08	221.9	-0.3142
179.63	-0.079	221.9	-0.3151
179.67	-0.079	221.9	-0.316
179.70	-0.08	221.8	-0.3169
179.73	-0.081	221.7	-0.3178
179.77	-0.081	221.7	-0.3178
179.80	-0.08	221.7	-0.3178
179.83	-0.08	221.6	-0.3178
179.87	-0.081	221.6	-0.3187
179.90	-0.081	221.6	-0.3196
179.93	-0.082	221.5	-0.3196
179.97	-0.082	221.4	-0.3204
180.00	-0.082	221.4	-0.3204
180.03	-0.082	221.3	-0.3213
180.07	-0.082	221.3	-0.3213
180.10	-0.083	221.2	-0.3213
180.15	-0.083	221.1	-0.3222
180.18	-0.083	221.1	-0.3231
180.20	-0.082	221.1	-0.3231
180.23	-0.082	221.1	-0.3231
180.27	-0.083	221.1	-0.324
180.30	-0.084	221	-0.3249
180.33	-0.084	220.9	-0.3249
180.37	-0.083	220.9	-0.3249
180.40	-0.083	220.9	-0.3249
180.43	-0.083	220.8	-0.3249
180.47	-0.083	220.8	-0.3258
180.50	-0.084	220.8	-0.3258
180.53	-0.085	220.7	-0.3267
180.57	-0.084	220.7	-0.3267
180.60	-0.084	220.7	-0.3267
180.63	-0.084	220.7	-0.3267
180.67	-0.084	220.7	-0.3267
180.70	-0.084	220.7	-0.3275
180.73	-0.084	220.6	-0.3275
180.77	-0.084	220.6	-0.3275
180.80	-0.084	220.6	-0.3284
180.83	-0.084	220.5	-0.3284
180.87	-0.085	220.5	-0.3284
180.90	-0.084	220.4	-0.3284
180.93	-0.084	220.4	-0.3293
180.97	-0.084	220.4	-0.3293
181.00	-0.084	220.4	-0.3293
181.03	-0.084	220.4	-0.3293
181.07	-0.084	220.4	-0.3293
181.10	-0.084	220.3	-0.3302
181.13	-0.084	220.3	-0.3302
181.17	-0.084	220.3	-0.3302
181.20	-0.084	220.3	-0.3302
181.23	-0.084	220.3	-0.3302
181.27	-0.084	220.3	-0.3302
181.30	-0.084	220.3	-0.3302

Prova triassiale ciclica SNME01-C3			
ensione di confinamento (kPa)		380	
deviatore ciclico (kPa)		80	
frequenza (hz)		0.00071429	
tempo	cella di carico	u	LVDT
(min)	kN	(kPa)	δ (mm)
181.33	-0.084	220.2	-0.3302
181.37	-0.083	220.2	-0.3302
181.40	-0.083	220.2	-0.3302
181.43	-0.083	220.2	-0.3311
181.47	-0.083	220.2	-0.3311
181.50	-0.083	220.2	-0.3311
181.53	-0.083	220.2	-0.3311
181.57	-0.082	220.2	-0.3311
181.62	-0.082	220.2	-0.3311
181.65	-0.082	220.2	-0.3311
181.67	-0.082	220.2	-0.3311
181.70	-0.082	220.2	-0.3311
181.73	-0.082	220.2	-0.3311
181.77	-0.082	220.2	-0.3311
181.80	-0.081	220.2	-0.3311
181.83	-0.081	220.2	-0.3311
181.87	-0.081	220.2	-0.3311
181.90	-0.081	220.2	-0.3311
181.93	-0.081	220.2	-0.3311
181.97	-0.081	220.2	-0.3311
182.00	-0.08	220.2	-0.3311
182.03	-0.08	220.2	-0.3302
182.07	-0.079	220.2	-0.3302
182.10	-0.079	220.2	-0.3302
182.13	-0.079	220.2	-0.3302
182.17	-0.079	220.2	-0.3302
182.20	-0.079	220.2	-0.3302
182.23	-0.079	220.2	-0.3302
182.27	-0.078	220.2	-0.3302
182.30	-0.078	220.2	-0.3302
182.33	-0.077	220.2	-0.3293
182.37	-0.077	220.3	-0.3293
182.40	-0.077	220.3	-0.3293
182.43	-0.077	220.3	-0.3293
182.47	-0.076	220.3	-0.3293
182.50	-0.076	220.3	-0.3293
182.53	-0.076	220.3	-0.3293
182.57	-0.075	220.3	-0.3284
182.60	-0.074	220.4	-0.3284
182.63	-0.074	220.4	-0.3284
182.67	-0.074	220.4	-0.3284
182.70	-0.074	220.4	-0.3284
182.73	-0.073	220.4	-0.3284
182.77	-0.073	220.4	-0.3284
182.80	-0.072	220.4	-0.3275
182.83	-0.072	220.5	-0.3275
182.87	-0.071	220.5	-0.3275
182.90	-0.071	220.5	-0.3275
182.93	-0.071	220.5	-0.3275
182.97	-0.07	220.6	-0.3267
183.00	-0.07	220.6	-0.3267
183.05	-0.069	220.6	-0.3267
183.08	-0.069	220.6	-0.3267
183.10	-0.068	220.7	-0.3258
183.13	-0.068	220.7	-0.3258
183.17	-0.068	220.7	-0.3258
183.20	-0.067	220.8	-0.3258
183.23	-0.066	220.8	-0.3249

Prova triassiale ciclica SNME01-C3			
pressione di confinamento (kPa)		380	
deviatore ciclico (kPa)		80	
frequenza (hz)		0.00071429	
tempo	cella di carico	u	LVDT
(min)	kN	(kPa)	δ (mm)
183.27	-0.066	220.8	-0.3249
183.30	-0.066	220.8	-0.3249
183.33	-0.065	220.8	-0.324
183.37	-0.065	220.9	-0.324
183.40	-0.064	220.9	-0.324
183.43	-0.063	221	-0.324
183.47	-0.063	221	-0.3231
183.50	-0.063	221	-0.3231
183.53	-0.062	221.1	-0.3222
183.57	-0.061	221.1	-0.3222
183.60	-0.061	221.1	-0.3213
183.63	-0.06	221.2	-0.3213
183.67	-0.06	221.2	-0.3213
183.70	-0.059	221.2	-0.3204
183.73	-0.059	221.2	-0.3204
183.77	-0.058	221.3	-0.3204
183.80	-0.057	221.4	-0.3196
183.83	-0.057	221.4	-0.3196
183.87	-0.057	221.4	-0.3187
183.90	-0.056	221.5	-0.3187
183.93	-0.055	221.5	-0.3187
183.97	-0.055	221.5	-0.3178
184.00	-0.054	221.6	-0.3178
184.03	-0.053	221.7	-0.3169
184.07	-0.053	221.7	-0.3169
184.10	-0.053	221.7	-0.316
184.13	-0.051	221.8	-0.316
184.17	-0.051	221.8	-0.316
184.20	-0.051	221.8	-0.3151
184.23	-0.05	221.9	-0.3142
184.27	-0.049	222	-0.3142
184.30	-0.048	222	-0.3133
184.33	-0.048	222.1	-0.3124
184.37	-0.047	222.2	-0.3124
184.40	-0.046	222.2	-0.3116
184.43	-0.046	222.2	-0.3116
184.47	-0.046	222.3	-0.3107
184.52	-0.044	222.4	-0.3098
184.55	-0.044	222.4	-0.3089
184.57	-0.043	222.5	-0.308
184.60	-0.042	222.6	-0.3071
184.63	-0.042	222.6	-0.3071
184.67	-0.042	222.6	-0.3062
184.70	-0.04	222.7	-0.3062
184.73	-0.039	222.7	-0.3045
184.77	-0.039	222.8	-0.3045
184.80	-0.039	222.9	-0.3036
184.83	-0.037	223	-0.3018
184.87	-0.037	223	-0.3009
184.90	-0.036	223.1	-0.3
184.93	-0.035	223.2	-0.3
184.97	-0.035	223.2	-0.2991
185.00	-0.035	223.3	-0.2982
185.03	-0.034	223.3	-0.2974
185.07	-0.033	223.4	-0.2965
185.10	-0.032	223.5	-0.2947
185.13	-0.031	223.6	-0.2938
185.17	-0.03	223.7	-0.2938

Prova triassiale ciclica SNME01-C3			
pressione di confinamento (kPa)		380	
deviatore ciclico (kPa)		80	
frequenza (hz)		0.00071429	
tempo	cella di carico	u	LVDT
(min)	kN	(kPa)	δ (mm)
185.20	-0.029	223.7	-0.2929
185.23	-0.029	223.8	-0.2911
185.27	-0.028	223.9	-0.2894
185.30	-0.027	224	-0.2885
185.33	-0.026	224.1	-0.2867
185.37	-0.026	224.1	-0.2858
185.40	-0.025	224.2	-0.2858
185.43	-0.024	224.2	-0.2832
185.47	-0.024	224.3	-0.2805
185.50	-0.023	224.5	-0.2778
185.53	-0.022	224.6	-0.2752
185.57	-0.021	224.7	-0.2734
185.60	-0.02	224.8	-0.2716
185.63	-0.019	224.9	-0.2716
185.67	-0.019	224.9	-0.269
185.70	-0.019	225	-0.2672
185.73	-0.018	225.1	-0.2645
185.77	-0.017	225.2	-0.2627
185.80	-0.016	225.3	-0.2601
185.83	-0.015	225.5	-0.2574
185.87	-0.014	225.6	-0.2574
185.90	-0.013	225.6	-0.2548
185.93	-0.013	225.6	-0.2521
185.98	-0.012	225.8	-0.2494
186.02	-0.011	225.8	-0.2477
186.03	-0.011	225.9	-0.245
186.07	-0.01	226	-0.2414
186.10	-0.008	226.2	-0.2379
186.13	-0.008	226.3	-0.2361
186.17	-0.007	226.4	-0.2326
186.20	-0.006	226.5	-0.2326
186.23	-0.005	226.5	-0.229
186.27	-0.005	226.6	-0.2263
186.30	-0.005	226.7	-0.2228
186.33	-0.003	226.9	-0.2192
186.37	-0.003	226.9	-0.2157
186.40	-0.002	227.1	-0.2121
186.43	0	227.2	-0.2121
186.47	0	227.2	-0.2077
186.50	0	227.3	-0.2042
186.53	0.001	227.5	-0.1997
186.57	0.003	227.6	-0.1953
186.60	0.003	227.7	-0.1917
186.63	0.004	227.8	-0.1882
186.67	0.006	228	-0.1882
186.70	0.006	228	-0.1837
186.73	0.006	228.1	-0.1793
186.77	0.007	228.2	-0.1749
186.80	0.009	228.3	-0.1713
186.83	0.008	228.4	-0.1695
186.87	0.01	228.5	-0.166
186.90	0.011	228.6	-0.166
186.93	0.012	228.6	-0.1633
186.97	0.012	228.7	-0.1607
187.00	0.012	228.8	-0.1571
187.03	0.014	229	-0.1544
187.07	0.014	229.1	-0.15
187.10	0.015	229.2	-0.1438

Prova triassiale ciclica SNME01-C3			
pressione di confinamento (kPa)		380	
deviatore ciclico (kPa)		80	
frequenza (hz)		0.00071429	
tempo	cella di carico	u	LVDT
(min)	kN	(kPa)	δ (mm)
187.13	0.017	229.4	-0.1438
187.17	0.017	229.4	-0.1376
187.20	0.017	229.5	-0.1331
187.23	0.017	229.6	-0.1278
187.27	0.02	229.8	-0.1225
187.30	0.02	229.8	-0.1181
187.33	0.021	230	-0.1127
187.37	0.022	230.2	-0.1127
187.42	0.023	230.2	-0.1021
187.45	0.023	230.3	-0.0985
187.47	0.024	230.5	-0.0985
187.50	0.026	230.5	-0.0932
187.53	0.026	230.6	-0.0888
187.57	0.026	230.7	-0.0843
187.60	0.028	230.8	-0.0799
187.63	0.028	230.9	-0.0763
187.67	0.029	231	-0.0728
187.70	0.03	231.1	-0.0728
187.73	0.03	231.1	-0.0683
187.77	0.03	231.2	-0.0648
187.80	0.032	231.3	-0.0621
187.83	0.033	231.4	-0.0595
187.87	0.034	231.5	-0.0559
187.90	0.036	231.6	-0.0541
187.93	0.035	231.6	-0.0541
187.97	0.036	231.6	-0.0524
188.00	0.036	231.7	-0.0515
188.03	0.037	231.7	-0.0497
188.07	0.039	231.9	-0.047
188.10	0.04	231.9	-0.0462
188.13	0.041	232	-0.0444
188.17	0.041	232.1	-0.0444
188.20	0.04	232.1	-0.0435
188.23	0.04	232	-0.0426
188.27	0.041	232.2	-0.0417
188.30	0.044	232.3	-0.0399
188.33	0.044	232.3	-0.0382
188.37	0.047	232.5	-0.0364
188.40	0.047	232.6	-0.0364
188.43	0.047	232.6	-0.0346
188.47	0.047	232.6	-0.0337
188.50	0.048	232.7	-0.0328
188.53	0.047	232.7	-0.0328
188.57	0.048	232.7	-0.0311
188.60	0.05	232.9	-0.0302
188.63	0.051	232.9	-0.0302
188.67	0.052	232.9	-0.0284
188.70	0.052	233	-0.0275
188.73	0.052	233.1	-0.0266
188.77	0.054	233.2	-0.0249
188.80	0.054	233.3	-0.024
188.83	0.055	233.4	-0.0222
188.88	0.058	233.5	-0.0213
188.92	0.054	233.5	-0.0204
188.93	0.056	233.6	-0.0195
188.97	0.059	233.7	-0.0195
189.00	0.058	233.7	-0.0186
189.03	0.058	233.7	-0.0169

Prova triassiale ciclica SNME01-C3			
pressione di confinamento (kPa)		380	
deviatore ciclico (kPa)		80	
frequenza (hz)		0.00071429	
tempo	cella di carico	u	LVDT
(min)	kN	(kPa)	δ (mm)
189.07	0.059	233.8	-0.016
189.10	0.062	234	-0.0133
189.13	0.062	234	-0.0133
189.17	0.061	234	-0.0124
189.20	0.06	234.1	-0.0124
189.23	0.064	234.1	-0.0115
189.27	0.064	234.2	-0.0107
189.30	0.063	234.2	-0.0098
189.33	0.064	234.3	-0.0089
189.37	0.064	234.3	-0.0089
189.40	0.065	234.4	-0.0071
189.43	0.067	234.5	-0.0071
189.47	0.067	234.5	-0.0062
189.50	0.067	234.6	-0.0053
189.53	0.068	234.7	-0.0044
189.57	0.069	234.7	-0.0036
189.60	0.069	234.8	-0.0027
189.63	0.07	234.8	-0.0018
189.67	0.071	234.9	-0.0018
189.70	0.071	234.9	0
189.73	0.071	235	0.0009
189.77	0.072	235.1	0.0018
189.80	0.073	235.1	0.0027
189.83	0.074	235.2	0.0036
189.87	0.073	235.3	0.0044
189.90	0.074	235.3	0.0044
189.93	0.076	235.3	0.0053
189.97	0.076	235.5	0.0062
190.00	0.075	235.5	0.0071
190.03	0.076	235.6	0.008
190.07	0.076	235.6	0.0089
190.10	0.077	235.7	0.0098
190.13	0.078	235.8	0.0098
190.17	0.079	235.8	0.0107
190.20	0.079	235.8	0.0115
190.23	0.079	235.9	0.0124
190.27	0.08	236	0.0133
190.32	0.08	236	0.0133
190.35	0.081	236.1	0.0142
190.37	0.081	236.2	0.0151
190.40	0.082	236.2	0.016
190.43	0.081	236.3	0.0169
190.47	0.082	236.3	0.0169
190.50	0.083	236.3	0.0169
190.53	0.083	236.4	0.0178
190.57	0.084	236.5	0.0186
190.60	0.084	236.5	0.0195
190.63	0.084	236.6	0.0204
190.67	0.084	236.7	0.0204
190.70	0.086	236.7	0.0204
190.73	0.086	236.7	0.0213
190.77	0.086	236.8	0.0222
190.80	0.086	236.8	0.0231
190.83	0.087	236.9	0.0231
190.87	0.087	236.9	0.024
190.90	0.09	237.1	0.0257
190.93	0.086	237	0.0257
190.97	0.087	237	0.0249

Prova triassiale ciclica SNME01-C3			
pressione di confinamento (kPa)		380	
deviatore ciclico (kPa)		80	
frequenza (hz)		0.00071429	
tempo	cella di carico	u	LVDT
(min)	kN	(kPa)	δ (mm)
191.00	0.087	237.1	0.0257
191.03	0.089	237.2	0.0266
191.07	0.089	237.2	0.0266
191.10	0.089	237.3	0.0275
191.13	0.09	237.4	0.0284
191.17	0.091	237.5	0.0284
191.20	0.091	237.5	0.0293
191.23	0.091	237.5	0.0293
191.27	0.092	237.6	0.0302
191.30	0.088	237.5	0.0302
191.33	0.091	237.6	0.0302
191.37	0.092	237.7	0.0311
191.40	0.094	237.8	0.0311
191.43	0.091	237.8	0.032
191.47	0.091	237.7	0.032
191.50	0.092	237.8	0.032
191.53	0.094	237.9	0.0328
191.57	0.093	237.9	0.0328
191.60	0.093	238	0.0337
191.63	0.093	238	0.0337
191.67	0.094	238	0.0337
191.70	0.094	238.1	0.0346
191.73	0.094	238.1	0.0346
191.78	0.094	238.1	0.0346
191.82	0.094	238.2	0.0355
191.83	0.094	238.2	0.0355
191.87	0.095	238.3	0.0364
191.90	0.094	238.3	0.0364
191.93	0.095	238.3	0.0364
191.97	0.096	238.4	0.0364
192.00	0.095	238.4	0.0373
192.03	0.095	238.4	0.0373
192.07	0.095	238.5	0.0382
192.10	0.096	238.6	0.0382
192.13	0.095	238.6	0.0382
192.17	0.096	238.6	0.0382
192.20	0.095	238.6	0.0382
192.23	0.096	238.6	0.0391
192.27	0.096	238.7	0.0391
192.30	0.096	238.7	0.0391
192.33	0.095	238.7	0.0391
192.37	0.096	238.8	0.0391
192.40	0.096	238.8	0.0399
192.43	0.096	238.8	0.0399
192.47	0.096	238.8	0.0399
192.50	0.096	238.8	0.0399
192.53	0.096	238.9	0.0399
192.57	0.097	238.9	0.0408
192.60	0.095	238.9	0.0399
192.63	0.095	239	0.0408
192.67	0.099	239.1	0.0408
192.70	0.097	239.1	0.0417
192.73	0.097	239.1	0.0399
192.77	0.093	239	0.0399
192.80	0.094	239	0.0408
192.83	0.096	239.1	0.0408
192.87	0.095	239.1	0.0408
192.90	0.095	239.1	0.0408

Prova triassiale ciclica SNME01-C3			
pressione di confinamento (kPa)		380	
deviatore ciclico (kPa)		80	
frequenza (hz)		0.00071429	
tempo	cella di carico	u	LVDT
(min)	kN	(kPa)	δ (mm)
192.93	0.095	239.1	0.0408
192.97	0.095	239.2	0.0417
193.00	0.095	239.2	0.0417
193.03	0.096	239.2	0.0417
193.07	0.095	239.2	0.0417
193.10	0.098	239.3	0.0417
193.13	0.092	239.2	0.0417
193.17	0.094	239.2	0.0408
193.22	0.094	239.3	0.0417
193.25	0.094	239.3	0.0417
193.27	0.094	239.3	0.0417
193.30	0.094	239.3	0.0417
193.33	0.094	239.3	0.0417
193.37	0.094	239.3	0.0417
193.40	0.093	239.4	0.0417
193.43	0.095	239.4	0.0417
193.47	0.092	239.4	0.0417
193.50	0.093	239.4	0.0408
193.53	0.093	239.4	0.0417
193.57	0.092	239.4	0.0408
193.60	0.092	239.4	0.0408
193.63	0.092	239.4	0.0408
193.67	0.092	239.4	0.0408
193.70	0.091	239.4	0.0408
193.73	0.091	239.4	0.0408
193.77	0.091	239.5	0.0408
193.80	0.091	239.5	0.0408
193.83	0.09	239.5	0.0408
193.87	0.09	239.5	0.0408
193.90	0.09	239.5	0.0408
193.93	0.089	239.5	0.0408
193.97	0.089	239.5	0.0408
194.00	0.089	239.5	0.0408
194.03	0.089	239.5	0.0399
194.07	0.088	239.5	0.0399
194.10	0.088	239.5	0.0399
194.13	0.088	239.5	0.0399
194.17	0.087	239.5	0.0399
194.20	0.087	239.5	0.0399
194.23	0.087	239.5	0.0399
194.27	0.086	239.5	0.0391
194.30	0.086	239.4	0.0391
194.33	0.086	239.4	0.0391
194.37	0.085	239.4	0.0391
194.40	0.084	239.4	0.0391
194.43	0.085	239.4	0.0391
194.47	0.085	239.4	0.0391
194.50	0.084	239.4	0.0382
194.53	0.083	239.4	0.0382
194.57	0.083	239.4	0.0382
194.60	0.082	239.4	0.0382
194.63	0.081	239.3	0.0382
194.68	0.081	239.3	0.0373
194.72	0.081	239.4	0.0373
194.73	0.08	239.3	0.0373
194.77	0.08	239.3	0.0373
194.80	0.08	239.3	0.0373
194.83	0.079	239.3	0.0364

Prova triassiale ciclica SNME01-C3			
pressione di confinamento (kPa)		380	
deviatore ciclico (kPa)		80	
frequenza (hz)		0.00071429	
tempo	cella di carico	u	LVDT
(min)	kN	(kPa)	δ (mm)
194.87	0.079	239.3	0.0364
194.90	0.078	239.3	0.0364
194.93	0.078	239.2	0.0355
194.97	0.077	239.2	0.0355
195.00	0.076	239.2	0.0355
195.03	0.076	239.2	0.0346
195.07	0.076	239.2	0.0346
195.10	0.076	239.2	0.0346
195.13	0.075	239.2	0.0346
195.17	0.074	239.1	0.0337
195.20	0.074	239.2	0.0337
195.23	0.073	239.2	0.0337
195.27	0.073	239.1	0.0328
195.30	0.072	239.1	0.0328
195.33	0.071	239	0.032
195.37	0.071	239	0.032
195.40	0.072	239	0.032
195.43	0.068	238.9	0.032
195.47	0.068	238.9	0.0311
195.50	0.068	238.9	0.0311
195.53	0.068	238.9	0.0302
195.57	0.068	238.9	0.0302
195.60	0.067	238.9	0.0293
195.63	0.066	238.8	0.0293
195.67	0.065	238.8	0.0293
195.70	0.066	238.8	0.0284
195.73	0.066	238.8	0.0284
195.77	0.064	238.7	0.0275
195.80	0.063	238.7	0.0275
195.83	0.063	238.7	0.0266
195.87	0.062	238.6	0.0257
195.90	0.06	238.6	0.0257
195.93	0.061	238.6	0.0257
195.97	0.061	238.6	0.0249
196.00	0.06	238.5	0.024
196.03	0.057	238.4	0.024
196.07	0.059	238.4	0.024
196.10	0.056	238.3	0.0222
196.15	0.056	238.3	0.0222
196.18	0.056	238.3	0.0213
196.20	0.055	238.3	0.0213
196.23	0.055	238.2	0.0213
196.27	0.053	238.2	0.0204
196.30	0.053	238.2	0.0195
196.33	0.053	238.2	0.0195
196.37	0.053	238.1	0.0186
196.40	0.051	238	0.0178
196.43	0.05	238	0.0169
196.47	0.05	238	0.0169
196.50	0.049	238	0.0169
196.53	0.049	237.9	0.0151
196.57	0.048	237.9	0.0151
196.60	0.047	237.8	0.0142
196.63	0.047	237.8	0.0133
196.67	0.045	237.7	0.0124
196.70	0.044	237.7	0.0124
196.73	0.043	237.7	0.0115
196.77	0.043	237.6	0.0107

Prova triassiale ciclica SNME01-C3			
pressione di confinamento (kPa)		380	
deviatore ciclico (kPa)		80	
frequenza (hz)		0.00071429	
tempo	cella di carico	u	LVDT
(min)	kN	(kPa)	δ (mm)
196.80	0.044	237.6	0.0107
196.83	0.041	237.5	0.0089
196.87	0.04	237.4	0.008
196.90	0.041	237.4	0.008
196.93	0.039	237.3	0.008
196.97	0.038	237.3	0.0071
197.00	0.038	237.3	0.0062
197.03	0.039	237.2	0.0053
197.07	0.037	237.2	0.0044
197.10	0.036	237.1	0.0036
197.13	0.035	237	0.0027
197.17	0.033	237	0.0027
197.20	0.033	237	0.0009
197.23	0.033	236.9	0.0009
197.27	0.032	236.9	-0.0009
197.30	0.031	236.8	-0.0018
197.33	0.03	236.7	-0.0027
197.37	0.029	236.7	-0.0036
197.40	0.029	236.6	-0.0036
197.43	0.027	236.6	-0.0044
197.47	0.027	236.5	-0.0062
197.50	0.028	236.5	-0.0062
197.53	0.025	236.4	-0.008
197.58	0.025	236.3	-0.0089
197.62	0.025	236.3	-0.0098
197.63	0.023	236.2	-0.0107
197.67	0.023	236.2	-0.0124
197.70	0.021	236.1	-0.0133
197.73	0.021	236	-0.0133
197.77	0.02	236	-0.0142
197.80	0.02	236	-0.0151
197.83	0.019	235.9	-0.0169
197.87	0.018	235.8	-0.0178
197.90	0.016	235.7	-0.0186
197.93	0.016	235.7	-0.0195
197.97	0.015	235.6	-0.0195
198.00	0.014	235.6	-0.0213
198.03	0.014	235.5	-0.0222
198.07	0.014	235.4	-0.0231
198.10	0.012	235.4	-0.0249
198.13	0.011	235.3	-0.0257
198.17	0.01	235.2	-0.0266
198.20	0.009	235.2	-0.0266
198.23	0.008	235.2	-0.0284
198.27	0.008	235.1	-0.0293
198.30	0.008	235	-0.0302
198.33	0.006	234.9	-0.032
198.37	0.005	234.9	-0.0328
198.40	0.005	234.8	-0.0346
198.43	0.004	234.7	-0.0346
198.47	0.003	234.7	-0.0355
198.50	0.003	234.6	-0.0373
198.53	0.002	234.6	-0.0391
198.57	0.001	234.4	-0.0399
198.60	0	234.4	-0.0408
198.63	-0.001	234.3	-0.0426
198.67	-0.002	234.2	-0.0426
198.70	-0.002	234.2	-0.0435

Prova triassiale ciclica SNME01-C3			
pressione di confinamento (kPa)		380	
deviatore ciclico (kPa)		80	
frequenza (hz)		0.00071429	
tempo	cella di carico	u	LVDT
(min)	kN	(kPa)	δ (mm)
198.73	-0.002	234.2	-0.0453
198.77	-0.004	234.1	-0.0462
198.80	-0.005	234	-0.0479
198.83	-0.006	233.9	-0.0488
198.87	-0.006	233.8	-0.0506
198.90	-0.008	233.7	-0.0506
198.93	-0.008	233.7	-0.0515
198.97	-0.008	233.7	-0.0524
199.00	-0.009	233.6	-0.0541
199.05	-0.012	233.5	-0.0559
199.08	-0.012	233.4	-0.0586
199.10	-0.011	233.3	-0.0604
199.13	-0.012	233.2	-0.0621
199.17	-0.014	233.1	-0.0639
199.20	-0.014	233	-0.0657
199.23	-0.016	232.9	-0.0657
199.27	-0.016	232.9	-0.0692
199.30	-0.016	232.8	-0.0746
199.33	-0.017	232.6	-0.079
199.37	-0.018	232.5	-0.0843
199.40	-0.019	232.4	-0.0897
199.43	-0.02	232.3	-0.0959
199.47	-0.021	232.1	-0.0959
199.50	-0.022	232.1	-0.103
199.53	-0.022	232	-0.1127
199.57	-0.022	231.8	-0.126
199.60	-0.024	231.6	-0.1438
199.63	-0.024	231.4	-0.1598
199.67	-0.024	231.3	-0.1713
199.70	-0.027	231	-0.1713
199.73	-0.028	231	-0.1802
199.77	-0.028	230.9	-0.1855
199.80	-0.028	230.8	-0.1882
199.83	-0.029	230.7	-0.1908
199.87	-0.03	230.5	-0.1971
199.90	-0.03	230.4	-0.2015
199.93	-0.032	230.2	-0.2015
199.97	-0.033	230.2	-0.2059
200.00	-0.033	230.1	-0.2095
200.03	-0.033	230	-0.2121
200.07	-0.034	229.8	-0.2157
200.10	-0.035	229.7	-0.2184
200.13	-0.036	229.5	-0.221
200.17	-0.037	229.4	-0.221
200.20	-0.037	229.4	-0.2237
200.23	-0.037	229.3	-0.2263
200.27	-0.038	229.2	-0.229
200.30	-0.039	229.1	-0.2317
200.33	-0.04	228.9	-0.2343
200.37	-0.04	228.8	-0.2361
200.40	-0.041	228.7	-0.2361
200.43	-0.042	228.7	-0.2388
200.48	-0.043	228.5	-0.2432
200.52	-0.044	228.4	-0.2432
200.53	-0.043	228.4	-0.245
200.57	-0.043	228.3	-0.2468
200.60	-0.045	228.2	-0.2494
200.63	-0.046	228	-0.2521

Prova triassiale ciclica SNME01-C3			
pressione di confinamento (kPa)		380	
deviatore ciclico (kPa)		80	
frequenza (hz)		0.00071429	
tempo	cella di carico	u	LVDT
(min)	kN	(kPa)	δ (mm)
200.67	-0.047	227.9	-0.2539
200.70	-0.047	227.8	-0.2556
200.73	-0.048	227.7	-0.2556
200.77	-0.049	227.7	-0.2574
200.80	-0.049	227.6	-0.2592
200.83	-0.049	227.5	-0.261
200.87	-0.051	227.4	-0.2636
200.90	-0.051	227.3	-0.2645
200.93	-0.052	227.2	-0.2663
200.97	-0.052	227.1	-0.2663
201.00	-0.054	227.1	-0.2681
201.03	-0.054	227	-0.2698
201.07	-0.054	226.9	-0.2716
201.10	-0.056	226.8	-0.2734
201.13	-0.054	226.8	-0.2743
201.17	-0.056	226.6	-0.2769
201.20	-0.057	226.5	-0.2769
201.23	-0.058	226.5	-0.2787
201.27	-0.058	226.4	-0.2796
201.30	-0.058	226.3	-0.2805
201.33	-0.058	226.2	-0.2823
201.37	-0.059	226.1	-0.2832
201.40	-0.06	226	-0.2858
201.43	-0.061	225.9	-0.2858
201.47	-0.061	225.9	-0.2876
201.50	-0.061	225.8	-0.2885
201.53	-0.063	225.7	-0.2894
201.57	-0.062	225.6	-0.2911
201.60	-0.064	225.6	-0.292
201.63	-0.064	225.5	-0.2929
201.67	-0.064	225.4	-0.2929
201.70	-0.064	225.4	-0.2947
201.73	-0.064	225.3	-0.2956
201.77	-0.066	225.2	-0.2965
201.80	-0.066	225.1	-0.2974
201.83	-0.067	225	-0.2982
201.87	-0.067	225	-0.2991
201.90	-0.068	224.9	-0.2991
201.95	-0.068	224.8	-0.3009
201.98	-0.068	224.8	-0.3018
202.00	-0.07	224.6	-0.3018
202.03	-0.07	224.6	-0.3036
202.07	-0.07	224.5	-0.3036
202.10	-0.07	224.5	-0.3045
202.13	-0.071	224.4	-0.3053
202.17	-0.071	224.3	-0.3062
202.20	-0.072	224.2	-0.3071
202.23	-0.073	224.2	-0.3071
202.27	-0.073	224.2	-0.308
202.30	-0.073	224.1	-0.3089
202.33	-0.072	224.1	-0.3098
202.37	-0.074	223.9	-0.3107
202.40	-0.074	223.9	-0.3116
202.43	-0.074	223.8	-0.3116
202.47	-0.074	223.8	-0.3116
202.50	-0.076	223.8	-0.3124
202.53	-0.076	223.7	-0.3133
202.57	-0.076	223.6	-0.3142

Prova triassiale ciclica SNME01-C3			
pressione di confinamento (kPa)		380	
deviatore ciclico (kPa)		80	
frequenza (hz)		0.00071429	
tempo	cella di carico	u	LVDT
(min)	kN	(kPa)	δ (mm)
202.60	-0.075	223.6	-0.3142
202.63	-0.076	223.5	-0.3151
202.67	-0.077	223.4	-0.316
202.70	-0.077	223.4	-0.316
202.73	-0.078	223.4	-0.3169
202.77	-0.078	223.3	-0.3169
202.80	-0.078	223.2	-0.3178
202.83	-0.078	223.2	-0.3187
202.87	-0.078	223.1	-0.3196
202.90	-0.079	223.1	-0.3196
202.93	-0.079	223	-0.3196
202.97	-0.079	223	-0.3204
203.00	-0.079	222.9	-0.3204
203.03	-0.08	222.9	-0.3213
203.07	-0.08	222.8	-0.3222
203.10	-0.081	222.8	-0.3222
203.13	-0.08	222.7	-0.3231
203.17	-0.081	222.7	-0.3231
203.20	-0.081	222.7	-0.3231
203.23	-0.081	222.6	-0.324
203.27	-0.081	222.6	-0.3249
203.30	-0.082	222.5	-0.3249
203.33	-0.082	222.5	-0.3258
203.37	-0.082	222.4	-0.3258
203.42	-0.083	222.3	-0.3267
203.43	-0.082	222.3	-0.3267
203.47	-0.082	222.3	-0.3275
203.50	-0.083	222.2	-0.3275
203.53	-0.083	222.2	-0.3275
203.57	-0.083	222.2	-0.3284
203.60	-0.083	222.2	-0.3284
203.63	-0.084	222.1	-0.3284
203.67	-0.083	222.1	-0.3293
203.70	-0.083	222.1	-0.3293
203.73	-0.084	222	-0.3293
203.77	-0.084	222	-0.3293
203.80	-0.084	222	-0.3302
203.83	-0.084	221.9	-0.3302
203.87	-0.084	221.9	-0.3302
203.90	-0.084	221.9	-0.3311
203.93	-0.084	221.8	-0.3311
203.97	-0.084	221.8	-0.3311
204.00	-0.085	221.8	-0.3311
204.03	-0.085	221.8	-0.332
204.07	-0.084	221.8	-0.332
204.10	-0.084	221.7	-0.332
204.13	-0.084	221.7	-0.332
204.17	-0.084	221.7	-0.3329
204.20	-0.085	221.6	-0.3329
204.23	-0.084	221.6	-0.3329
204.27	-0.084	221.6	-0.3329
204.30	-0.085	221.6	-0.3329
204.33	-0.084	221.6	-0.3329
204.37	-0.084	221.6	-0.3338
204.40	-0.084	221.5	-0.3338
204.43	-0.084	221.5	-0.3338
204.47	-0.084	221.5	-0.3338
204.50	-0.084	221.5	-0.3338

Prova triassiale ciclica SNME01-C3			
pressione di confinamento (kPa)		380	
deviatore ciclico (kPa)		80	
frequenza (hz)		0.00071429	
tempo	cella di carico	u	LVDT
(min)	kN	(kPa)	δ (mm)
204.53	-0.084	221.5	-0.3338
204.57	-0.084	221.5	-0.3338
204.60	-0.084	221.4	-0.3346
204.63	-0.083	221.4	-0.3346
204.67	-0.083	221.4	-0.3346
204.70	-0.083	221.4	-0.3346
204.73	-0.083	221.4	-0.3346
204.77	-0.083	221.4	-0.3346
204.80	-0.083	221.4	-0.3346
204.85	-0.083	221.4	-0.3346
204.88	-0.083	221.4	-0.3346
204.90	-0.082	221.4	-0.3346
204.93	-0.083	221.3	-0.3346
204.97	-0.082	221.4	-0.3346
205.00	-0.082	221.3	-0.3346
205.03	-0.082	221.3	-0.3346
205.07	-0.082	221.3	-0.3346
205.10	-0.082	221.4	-0.3346
205.13	-0.082	221.3	-0.3346
205.17	-0.081	221.3	-0.3346
205.20	-0.081	221.3	-0.3346
205.23	-0.081	221.3	-0.3346
205.27	-0.081	221.3	-0.3346
205.30	-0.081	221.3	-0.3346
205.33	-0.08	221.3	-0.3346
205.37	-0.08	221.3	-0.3346
205.40	-0.079	221.4	-0.3346
205.43	-0.079	221.4	-0.3346
205.47	-0.079	221.4	-0.3346
205.50	-0.079	221.4	-0.3346
205.53	-0.079	221.4	-0.3346
205.57	-0.078	221.4	-0.3338
205.60	-0.078	221.4	-0.3338
205.63	-0.078	221.4	-0.3338
205.67	-0.077	221.4	-0.3338
205.70	-0.077	221.4	-0.3338
205.73	-0.076	221.4	-0.3338
205.77	-0.076	221.4	-0.3338
205.80	-0.076	221.4	-0.3338
205.83	-0.076	221.4	-0.3329
205.87	-0.075	221.5	-0.3329
205.90	-0.075	221.5	-0.3329
205.93	-0.074	221.5	-0.3329
205.97	-0.074	221.5	-0.3329
206.00	-0.074	221.5	-0.3329
206.03	-0.074	221.5	-0.332
206.07	-0.073	221.6	-0.332
206.10	-0.073	221.6	-0.332
206.13	-0.072	221.6	-0.332
206.17	-0.072	221.6	-0.332
206.20	-0.072	221.6	-0.332
206.23	-0.072	221.6	-0.3311
206.27	-0.071	221.7	-0.3311
206.32	-0.07	221.7	-0.3302
206.35	-0.07	221.7	-0.3302
206.37	-0.07	221.7	-0.3302
206.40	-0.069	221.7	-0.3302
206.43	-0.069	221.8	-0.3302

Prova triassiale ciclica SNME01-C3			
ensione di confinamento (kPa)		380	
deviatore ciclico (kPa)		80	
frequenza (hz)		0.00071429	
tempo	cella di carico	u	LVDT
(min)	kN	(kPa)	δ (mm)
206.47	-0.068	221.8	-0.3293
206.50	-0.067	221.8	-0.3293
206.53	-0.067	221.9	-0.3293
206.57	-0.067	221.9	-0.3293
206.60	-0.066	221.9	-0.3284
206.63	-0.066	221.9	-0.3284
206.67	-0.065	222	-0.3284
206.70	-0.065	222	-0.3275
206.73	-0.064	222.1	-0.3275
206.77	-0.063	222.1	-0.3275
206.80	-0.063	222.1	-0.3267
206.83	-0.063	222.1	-0.3267
206.87	-0.062	222.1	-0.3258
206.90	-0.061	222.2	-0.3258
206.93	-0.061	222.2	-0.3249
206.97	-0.06	222.3	-0.3249
207.00	-0.06	222.3	-0.3249
207.03	-0.06	222.3	-0.3249
207.07	-0.059	222.4	-0.324
207.10	-0.058	222.4	-0.3231
207.13	-0.058	222.5	-0.3231
207.17	-0.057	222.5	-0.3222
207.20	-0.056	222.6	-0.3222
207.23	-0.055	222.7	-0.3213
207.27	-0.055	222.7	-0.3213
207.30	-0.055	222.7	-0.3204
207.33	-0.054	222.7	-0.3204
207.37	-0.053	222.8	-0.3196
207.40	-0.053	222.8	-0.3196
207.43	-0.052	222.9	-0.3196
207.47	-0.052	222.9	-0.3187
207.50	-0.052	222.9	-0.3187
207.53	-0.051	223	-0.3178
207.57	-0.049	223.1	-0.3169
207.60	-0.049	223.1	-0.316
207.63	-0.048	223.2	-0.3151
207.67	-0.047	223.3	-0.3151
207.70	-0.047	223.3	-0.3151
207.75	-0.047	223.3	-0.3133
207.78	-0.045	223.5	-0.3133
207.80	-0.045	223.4	-0.3124
207.83	-0.045	223.4	-0.3124
207.87	-0.044	223.5	-0.3116
207.90	-0.043	223.6	-0.3107
207.93	-0.042	223.7	-0.3098
207.97	-0.042	223.7	-0.3089
208.00	-0.04	223.8	-0.3089
208.03	-0.04	223.9	-0.308
208.07	-0.04	223.9	-0.308
208.10	-0.04	223.9	-0.3062
208.13	-0.039	224	-0.3053
208.17	-0.036	224.1	-0.3045
208.20	-0.038	224.1	-0.3036
208.23	-0.036	224.2	-0.3036
208.27	-0.035	224.3	-0.3027
208.30	-0.035	224.3	-0.3018
208.33	-0.034	224.4	-0.3
208.37	-0.033	224.5	-0.2991

Prova triassiale ciclica SNME01-C3			
pressione di confinamento (kPa)		380	
deviatore ciclico (kPa)		80	
frequenza (hz)		0.00071429	
tempo	cella di carico	u	LVDT
(min)	kN	(kPa)	δ (mm)
208.40	-0.032	224.6	-0.2982
208.43	-0.032	224.6	-0.2974
208.47	-0.031	224.8	-0.2974
208.50	-0.03	224.9	-0.2956
208.53	-0.03	224.9	-0.2947
208.57	-0.03	224.9	-0.2929
208.60	-0.029	225	-0.2911
208.63	-0.027	225.1	-0.2903
208.67	-0.027	225.2	-0.2885
208.70	-0.025	225.3	-0.2885
208.73	-0.025	225.4	-0.2867
208.77	-0.025	225.4	-0.2832
208.80	-0.025	225.5	-0.2823
208.83	-0.022	225.6	-0.2796
208.87	-0.023	225.7	-0.2778
208.90	-0.021	225.8	-0.2752
208.93	-0.02	225.9	-0.2752
208.97	-0.02	226	-0.2734
209.00	-0.02	226	-0.2707
209.03	-0.018	226.1	-0.269
209.07	-0.017	226.2	-0.2663
209.10	-0.017	226.3	-0.2645
209.13	-0.015	226.5	-0.261
209.17	-0.015	226.6	-0.261
209.22	-0.014	226.6	-0.2574
209.25	-0.014	226.7	-0.2548
209.27	-0.013	226.8	-0.2548
209.30	-0.011	227	-0.253
209.33	-0.011	227	-0.2494
209.37	-0.011	227	-0.2477
209.40	-0.01	227.2	-0.245
209.43	-0.009	227.3	-0.2406
209.47	-0.008	227.4	-0.2379
209.50	-0.006	227.6	-0.2379
209.53	-0.006	227.6	-0.2343
209.57	-0.006	227.6	-0.2308
209.60	-0.005	227.8	-0.2272
209.63	-0.004	227.9	-0.2237
209.67	-0.003	228	-0.2201
209.70	-0.002	228.1	-0.2166
209.73	-0.001	228.2	-0.2166
209.77	0	228.4	-0.213
209.80	0	228.4	-0.2095
209.83	0.001	228.5	-0.205
209.87	0.001	228.6	-0.2015
209.90	0.003	228.7	-0.1979
209.93	0.003	228.8	-0.1935
209.97	0.005	229	-0.1935
210.00	0.005	229.1	-0.19
210.03	0.005	229.1	-0.1855
210.07	0.006	229.2	-0.1829
210.10	0.007	229.3	-0.1802
210.13	0.009	229.4	-0.1766
210.17	0.009	229.6	-0.1713
210.20	0.01	229.7	-0.1713
210.23	0.011	229.8	-0.1651
210.27	0.011	229.8	-0.1589
210.30	0.012	230	-0.1536

Prova triassiale ciclica SNME01-C3			
pressione di confinamento (kPa)		380	
deviatore ciclico (kPa)		80	
frequenza (hz)		0.00071429	
tempo	cella di carico	u	LVDT
(min)	kN	(kPa)	δ (mm)
210.33	0.013	230.1	-0.1482
210.37	0.014	230.3	-0.1429
210.40	0.014	230.4	-0.1385
210.43	0.016	230.5	-0.1385
210.47	0.017	230.6	-0.1331
210.50	0.017	230.6	-0.1287
210.53	0.017	230.7	-0.1243
210.57	0.019	230.9	-0.1198
210.60	0.019	231	-0.1154
210.65	0.02	231.1	-0.1101
210.68	0.021	231.2	-0.1065
210.70	0.022	231.3	-0.1021
210.73	0.022	231.4	-0.0985
210.77	0.023	231.6	-0.0985
210.80	0.025	231.7	-0.0941
210.83	0.025	231.7	-0.0897
210.87	0.025	231.7	-0.0861
210.90	0.027	231.9	-0.0817
210.93	0.027	232	-0.0781
210.97	0.028	232.1	-0.0746
211.00	0.03	232.2	-0.0746
211.03	0.03	232.3	-0.071
211.07	0.03	232.3	-0.0683
211.10	0.03	232.3	-0.0657
211.13	0.032	232.5	-0.063
211.17	0.033	232.5	-0.0604
211.20	0.034	232.6	-0.0586
211.23	0.034	232.7	-0.0586
211.27	0.036	232.7	-0.0559
211.30	0.036	232.7	-0.0541
211.33	0.036	232.8	-0.0533
211.37	0.037	232.9	-0.0515
211.40	0.039	232.9	-0.0497
211.43	0.038	233	-0.0479
211.47	0.04	233.1	-0.0479
211.50	0.041	233.2	-0.0462
211.53	0.041	233.2	-0.0453
211.57	0.041	233.3	-0.0444
211.60	0.043	233.4	-0.0426
211.63	0.043	233.4	-0.0408
211.67	0.045	233.5	-0.0399
211.70	0.045	233.6	-0.0399
211.73	0.046	233.6	-0.0382
211.77	0.046	233.6	-0.0373
211.80	0.046	233.7	-0.0364
211.83	0.048	233.8	-0.0346
211.87	0.048	233.9	-0.0337
211.90	0.05	234	-0.032
211.93	0.05	234	-0.032
211.97	0.052	234.1	-0.0311
212.00	0.052	234.1	-0.0302
212.03	0.051	234.2	-0.0293
212.07	0.052	234.2	-0.0284
212.12	0.054	234.3	-0.0266
212.15	0.053	234.4	-0.0257
212.17	0.055	234.4	-0.0249
212.20	0.056	234.5	-0.0231
212.23	0.055	234.6	-0.0222

Prova triassiale ciclica SNME01-C3			
pressione di confinamento (kPa)		380	
deviatore ciclico (kPa)		80	
frequenza (hz)		0.00071429	
tempo	cella di carico	u	LVDT
(min)	kN	(kPa)	δ (mm)
212.27	0.057	234.7	-0.0222
212.30	0.058	234.8	-0.0213
212.33	0.058	234.8	-0.0204
212.37	0.058	234.8	-0.0195
212.40	0.059	234.9	-0.0178
212.43	0.06	235	-0.0169
212.47	0.061	235	-0.016
212.50	0.061	235.1	-0.016
212.53	0.063	235.2	-0.0151
212.57	0.063	235.2	-0.0142
212.60	0.062	235.3	-0.0133
212.63	0.064	235.4	-0.0115
212.67	0.064	235.4	-0.0107
212.70	0.066	235.5	-0.0089
212.73	0.066	235.6	-0.0089
212.77	0.067	235.7	-0.008
212.80	0.067	235.7	-0.0071
212.83	0.067	235.7	-0.0062
212.87	0.068	235.8	-0.0053
212.90	0.069	235.9	-0.0044
212.93	0.069	235.9	-0.0036
212.97	0.07	236	-0.0036
213.00	0.072	236.1	-0.0027
213.03	0.072	236.1	-0.0018
213.07	0.071	236.1	-0.0009
213.10	0.071	236.2	0
213.13	0.073	236.3	0.0009
213.17	0.074	236.4	0.0027
213.20	0.073	236.4	0.0027
213.23	0.074	236.5	0.0027
213.27	0.074	236.5	0.0036
213.30	0.074	236.5	0.0044
213.33	0.076	236.6	0.0053
213.37	0.077	236.7	0.0062
213.40	0.077	236.8	0.0071
213.43	0.077	236.8	0.0071
213.47	0.078	236.9	0.008
213.50	0.078	236.9	0.008
213.53	0.079	237	0.0098
213.58	0.079	237.1	0.0098
213.62	0.079	237.1	0.0107
213.63	0.08	237.2	0.0115
213.67	0.081	237.2	0.0124
213.70	0.081	237.3	0.0133
213.73	0.082	237.4	0.0142
213.77	0.082	237.4	0.0142
213.80	0.082	237.5	0.0142
213.83	0.082	237.5	0.0151
213.87	0.083	237.6	0.0169
213.90	0.084	237.7	0.0169
213.93	0.085	237.7	0.0178
213.97	0.084	237.8	0.0186
214.00	0.085	237.8	0.0186
214.03	0.085	237.9	0.0186
214.07	0.085	237.9	0.0195
214.10	0.085	237.9	0.0204
214.13	0.086	238	0.0213
214.17	0.087	238.1	0.0213

Prova triassiale ciclica SNME01-C3			
pressione di confinamento (kPa)		380	
deviatore ciclico (kPa)		80	
frequenza (hz)		0.00071429	
tempo	cella di carico	u	LVDT
(min)	kN	(kPa)	δ (mm)
214.20	0.087	238.1	0.0222
214.23	0.087	238.2	0.0222
214.27	0.088	238.2	0.0231
214.30	0.088	238.2	0.0231
214.33	0.088	238.3	0.024
214.37	0.089	238.4	0.024
214.40	0.089	238.4	0.0249
214.43	0.09	238.5	0.0257
214.47	0.089	238.5	0.0257
214.50	0.09	238.6	0.0257
214.53	0.09	238.6	0.0266
214.57	0.09	238.7	0.0266
214.60	0.091	238.7	0.0275
214.63	0.093	238.8	0.0293
214.67	0.093	238.9	0.0293
214.70	0.092	238.9	0.0293
214.73	0.092	238.9	0.0293
214.77	0.092	238.9	0.0293
214.80	0.09	238.9	0.0293
214.83	0.091	239	0.0302
214.87	0.094	239.1	0.0311
214.90	0.092	239.1	0.0311
214.93	0.093	239.1	0.0311
214.97	0.093	239.2	0.0311
215.02	0.094	239.2	0.032
215.05	0.094	239.3	0.0328
215.07	0.094	239.3	0.0328
215.10	0.094	239.3	0.0328
215.13	0.094	239.3	0.0328
215.17	0.094	239.4	0.0337
215.20	0.095	239.4	0.0337
215.23	0.094	239.5	0.0337
215.27	0.096	239.5	0.0337
215.30	0.097	239.6	0.0346
215.33	0.097	239.6	0.0355
215.37	0.096	239.6	0.0355
215.40	0.095	239.6	0.0355
215.43	0.095	239.7	0.0355
215.47	0.095	239.7	0.0364
215.50	0.095	239.7	0.0364
215.53	0.096	239.8	0.0364
215.57	0.096	239.8	0.0364
215.60	0.096	239.8	0.0364
215.63	0.096	239.8	0.0373
215.67	0.095	239.9	0.0373
215.70	0.096	239.9	0.0373
215.73	0.096	239.9	0.0373
215.77	0.096	240	0.0373
215.80	0.096	240	0.0373
215.83	0.096	240	0.0382
215.87	0.094	240	0.0373
215.90	0.095	240	0.0382
215.93	0.095	240.1	0.0382
215.97	0.096	240.1	0.0382
216.00	0.097	240.1	0.0382
216.03	0.097	240.1	0.0382
216.07	0.096	240.2	0.0391
216.10	0.096	240.2	0.0391

Prova triassiale ciclica SNME01-C3			
pressione di confinamento (kPa)		380	
deviatore ciclico (kPa)		80	
frequenza (hz)		0.00071429	
tempo	cella di carico	u	LVDT
(min)	kN	(kPa)	δ (mm)
216.13	0.097	240.3	0.0391
216.17	0.097	240.3	0.0391
216.20	0.096	240.3	0.0391
216.23	0.095	240.3	0.0391
216.27	0.095	240.3	0.0391
216.30	0.093	240.2	0.0391
216.33	0.093	240.2	0.0391
216.37	0.095	240.3	0.0391
216.40	0.095	240.3	0.0391
216.43	0.095	240.4	0.0391
216.48	0.095	240.4	0.0391
216.52	0.094	240.4	0.0391
216.53	0.094	240.4	0.0391
216.57	0.095	240.4	0.0391
216.60	0.095	240.4	0.0391
216.63	0.094	240.4	0.0391
216.67	0.094	240.4	0.0391
216.70	0.094	240.5	0.0391
216.73	0.093	240.5	0.0391
216.77	0.093	240.5	0.0391
216.80	0.093	240.5	0.0391
216.83	0.093	240.5	0.0391
216.87	0.093	240.5	0.0391
216.90	0.092	240.5	0.0391
216.93	0.092	240.5	0.0391
216.97	0.092	240.5	0.0391
217.00	0.092	240.5	0.0391
217.03	0.092	240.6	0.0391
217.07	0.091	240.6	0.0391
217.10	0.091	240.5	0.0391
217.13	0.091	240.6	0.0391
217.17	0.091	240.6	0.0391
217.20	0.09	240.6	0.0382
217.23	0.09	240.6	0.0382
217.27	0.09	240.6	0.0382
217.30	0.089	240.6	0.0382
217.33	0.089	240.5	0.0382
217.37	0.088	240.6	0.0382
217.40	0.088	240.6	0.0382
217.43	0.088	240.6	0.0382
217.47	0.088	240.6	0.0382
217.50	0.087	240.6	0.0382
217.53	0.087	240.6	0.0373
217.57	0.087	240.6	0.0373
217.60	0.087	240.6	0.0373
217.63	0.086	240.5	0.0373
217.67	0.085	240.5	0.0373
217.70	0.085	240.5	0.0373
217.73	0.085	240.5	0.0373
217.77	0.084	240.5	0.0364
217.80	0.084	240.5	0.0364
217.83	0.084	240.5	0.0364
217.87	0.083	240.5	0.0364
217.92	0.082	240.5	0.0364
217.95	0.083	240.5	0.0355
217.97	0.082	240.5	0.0355
218.00	0.081	240.4	0.0355
218.03	0.081	240.4	0.0355

Prova triassiale ciclica SNME01-C3			
pressione di confinamento (kPa)		380	
deviatore ciclico (kPa)		80	
frequenza (hz)		0.00071429	
tempo	cella di carico	u	LVDT
(min)	kN	(kPa)	δ (mm)
218.07	0.08	240.4	0.0355
218.10	0.08	240.4	0.0346
218.13	0.08	240.4	0.0346
218.17	0.079	240.4	0.0346
218.20	0.079	240.4	0.0346
218.23	0.078	240.4	0.0337
218.27	0.078	240.3	0.0337
218.30	0.077	240.3	0.0337
218.33	0.077	240.3	0.0337
218.37	0.077	240.3	0.0337
218.40	0.076	240.3	0.0328
218.43	0.075	240.3	0.0328
218.47	0.074	240.2	0.032
218.50	0.074	240.2	0.032
218.53	0.073	240.2	0.032
218.57	0.073	240.2	0.0311
218.60	0.073	240.2	0.0311
218.63	0.072	240.1	0.0311
218.67	0.071	240.1	0.0302
218.70	0.071	240.1	0.0302
218.73	0.07	240.1	0.0293
218.77	0.069	240	0.0293
218.80	0.069	240	0.0293
218.83	0.069	240	0.0293
218.87	0.068	240	0.0284
218.90	0.067	239.9	0.0284
218.93	0.067	239.9	0.0275
218.97	0.066	239.9	0.0275
219.00	0.065	239.8	0.0275
219.03	0.065	239.8	0.0266
219.07	0.065	239.8	0.0266
219.10	0.064	239.8	0.0257
219.13	0.063	239.8	0.0249
219.17	0.062	239.7	0.0249
219.20	0.062	239.7	0.024
219.23	0.061	239.7	0.024
219.27	0.06	239.7	0.024
219.30	0.06	239.6	0.0231
219.33	0.06	239.6	0.0231
219.38	0.058	239.6	0.0222
219.42	0.058	239.5	0.0213
219.43	0.058	239.5	0.0213
219.47	0.056	239.4	0.0204
219.50	0.056	239.4	0.0195
219.53	0.056	239.4	0.0195
219.57	0.055	239.3	0.0195
219.60	0.053	239.3	0.0186
219.63	0.053	239.3	0.0178
219.67	0.053	239.2	0.0169
219.70	0.053	239.2	0.0169
219.73	0.051	239.1	0.016
219.77	0.05	239.1	0.0151
219.80	0.05	239	0.0151
219.83	0.049	239	0.0142
219.87	0.049	239	0.0142
219.90	0.048	238.9	0.0133
219.93	0.047	238.9	0.0124
219.97	0.046	238.8	0.0115

Prova triassiale ciclica SNME01-C3			
pressione di confinamento (kPa)		380	
deviatore ciclico (kPa)		80	
frequenza (hz)		0.00071429	
tempo	cella di carico	u	LVDT
(min)	kN	(kPa)	δ (mm)
220.00	0.045	238.8	0.0107
220.03	0.044	238.7	0.0107
220.07	0.044	238.7	0.0098
220.10	0.044	238.7	0.0089
220.13	0.043	238.6	0.008
220.17	0.041	238.6	0.0071
220.20	0.041	238.5	0.0062
220.23	0.04	238.4	0.0053
220.27	0.039	238.4	0.0053
220.30	0.038	238.4	0.0044
220.33	0.038	238.3	0.0044
220.37	0.037	238.3	0.0036
220.40	0.037	238.2	0.0027
220.43	0.036	238.2	0.0018
220.47	0.035	238.1	0.0009
220.50	0.034	238	0.0009
220.53	0.033	238	-0.0009
220.57	0.033	238	-0.0018
220.60	0.032	237.9	-0.0027
220.63	0.031	237.9	-0.0036
220.67	0.03	237.8	-0.0044
220.70	0.03	237.7	-0.0053
220.73	0.028	237.7	-0.0053
220.77	0.027	237.7	-0.0062
220.80	0.027	237.6	-0.0071
220.85	0.026	237.5	-0.008
220.87	0.025	237.5	-0.0089
220.90	0.025	237.4	-0.0107
220.93	0.025	237.4	-0.0115
220.97	0.024	237.3	-0.0124
221.00	0.022	237.2	-0.0142
221.03	0.022	237.1	-0.0151
221.07	0.02	237	-0.0151
221.10	0.02	237	-0.016
221.13	0.02	237	-0.0169
221.17	0.019	236.9	-0.0186
221.20	0.018	236.8	-0.0195
221.23	0.017	236.8	-0.0204
221.27	0.016	236.7	-0.0213
221.30	0.015	236.6	-0.0213
221.33	0.014	236.6	-0.0231
221.37	0.014	236.5	-0.024
221.40	0.014	236.5	-0.0249
221.43	0.012	236.4	-0.0266
221.47	0.011	236.3	-0.0275
221.50	0.01	236.3	-0.0284
221.53	0.009	236.2	-0.0284
221.57	0.009	236.2	-0.0302
221.60	0.009	236.1	-0.0311
221.63	0.007	236	-0.0328
221.67	0.006	235.9	-0.0337
221.70	0.006	235.9	-0.0346
221.73	0.005	235.8	-0.0364
221.77	0.004	235.7	-0.0364
221.80	0.003	235.7	-0.0373
221.83	0.003	235.6	-0.0391
221.87	0.002	235.5	-0.0399
221.90	0	235.4	-0.0417

Prova triassiale ciclica SNME01-C3			
pressione di confinamento (kPa)		380	
deviatore ciclico (kPa)		80	
frequenza (hz)		0.00071429	
tempo	cella di carico	u	LVDT
(min)	kN	(kPa)	δ (mm)
221.93	0.001	235.4	-0.0426
221.97	-0.001	235.3	-0.0435
222.00	-0.002	235.2	-0.0435
222.03	-0.003	235.2	-0.0453
222.07	-0.003	235.1	-0.047
222.10	-0.004	235	-0.0479
222.13	-0.005	234.9	-0.0488
222.17	-0.006	234.9	-0.0506
222.20	-0.007	234.8	-0.0515
222.23	-0.008	234.7	-0.0515
222.28	-0.008	234.6	-0.0541
222.32	-0.009	234.5	-0.0559
222.33	-0.011	234.4	-0.0559
222.37	-0.01	234.4	-0.0586
222.40	-0.01	234.4	-0.0595
222.43	-0.012	234.2	-0.0621
222.47	-0.014	234.2	-0.0639
222.50	-0.014	234.1	-0.0683
222.53	-0.014	234	-0.0719
222.57	-0.016	233.8	-0.0719
222.60	-0.016	233.8	-0.0763
222.63	-0.016	233.7	-0.0808
222.67	-0.017	233.6	-0.0843
222.70	-0.019	233.5	-0.0897
222.73	-0.019	233.4	-0.0941
222.77	-0.02	233.2	-0.1003
222.80	-0.022	233	-0.1003
222.83	-0.021	233	-0.1074
222.87	-0.021	233	-0.1145
222.90	-0.023	232.8	-0.126
222.93	-0.024	232.6	-0.1402
222.97	-0.024	232.5	-0.1571
223.00	-0.026	232.2	-0.1731
223.03	-0.027	232	-0.1731
223.07	-0.027	232	-0.1829
223.10	-0.027	231.8	-0.1891
223.13	-0.028	231.7	-0.1944
223.17	-0.029	231.5	-0.1988
223.20	-0.03	231.4	-0.2015
223.23	-0.03	231.3	-0.2033
223.27	-0.032	231.2	-0.2033
223.30	-0.032	231.2	-0.205
223.33	-0.032	231.1	-0.2068
223.37	-0.033	231	-0.2086
223.40	-0.034	230.8	-0.2166
223.43	-0.035	230.7	-0.2201
223.47	-0.036	230.5	-0.2228
223.50	-0.036	230.4	-0.2228
223.53	-0.038	230.4	-0.2263
223.57	-0.038	230.3	-0.229
223.60	-0.038	230.2	-0.2317
223.63	-0.039	230	-0.2343
223.67	-0.04	229.9	-0.237
223.70	-0.041	229.8	-0.2397
223.75	-0.041	229.7	-0.2414
223.78	-0.042	229.6	-0.2432
223.80	-0.042	229.5	-0.2459
223.83	-0.044	229.3	-0.2459

Prova triassiale ciclica SNME01-C3			
pressione di confinamento (kPa)		380	
deviatore ciclico (kPa)		80	
frequenza (hz)		0.00071429	
tempo	cella di carico	u	LVDT
(min)	kN	(kPa)	δ (mm)
223.87	-0.045	229.3	-0.2485
223.90	-0.045	229.2	-0.2503
223.93	-0.045	229.1	-0.2521
223.97	-0.046	229	-0.2548
224.00	-0.047	228.9	-0.2565
224.03	-0.047	228.8	-0.2583
224.07	-0.048	228.6	-0.2583
224.10	-0.049	228.6	-0.2601
224.13	-0.049	228.5	-0.2627
224.17	-0.05	228.4	-0.2645
224.20	-0.051	228.3	-0.2663
224.23	-0.051	228.2	-0.2681
224.27	-0.052	228.1	-0.2698
224.30	-0.053	228	-0.2698
224.33	-0.054	228	-0.2716
224.37	-0.054	227.9	-0.2734
224.40	-0.054	227.8	-0.2752
224.43	-0.055	227.7	-0.2761
224.47	-0.055	227.6	-0.2778
224.50	-0.056	227.5	-0.2787
224.53	-0.057	227.4	-0.2787
224.57	-0.058	227.4	-0.2814
224.60	-0.058	227.3	-0.2823
224.63	-0.058	227.2	-0.284
224.67	-0.058	227.1	-0.2858
224.70	-0.059	227	-0.2876
224.73	-0.06	226.9	-0.2894
224.77	-0.061	226.8	-0.2894
224.80	-0.061	226.8	-0.2903
224.83	-0.061	226.7	-0.292
224.87	-0.062	226.6	-0.2929
224.90	-0.063	226.5	-0.2947
224.93	-0.063	226.4	-0.2956
224.97	-0.064	226.3	-0.2974
225.00	-0.065	226.2	-0.2974
225.03	-0.064	226.2	-0.2982
225.07	-0.064	226.2	-0.2991
225.10	-0.065	226.1	-0.3
225.13	-0.067	225.9	-0.3018
225.18	-0.067	225.9	-0.3027
225.22	-0.067	225.8	-0.3036
225.23	-0.067	225.7	-0.3045
225.27	-0.068	225.6	-0.3053
225.30	-0.069	225.6	-0.3062
225.33	-0.069	225.5	-0.3062
225.37	-0.07	225.5	-0.3071
225.40	-0.07	225.4	-0.308
225.43	-0.071	225.4	-0.3089
225.47	-0.07	225.3	-0.3098
225.50	-0.071	225.2	-0.3107
225.53	-0.072	225.1	-0.3107
225.57	-0.072	225.1	-0.3107
225.60	-0.073	225.1	-0.3116
225.63	-0.073	225	-0.3124
225.67	-0.073	224.9	-0.3133
225.70	-0.074	224.8	-0.3142
225.73	-0.074	224.8	-0.3151
225.77	-0.074	224.7	-0.316

Prova triassiale ciclica SNME01-C3			
pressione di confinamento (kPa)		380	
deviatore ciclico (kPa)		80	
frequenza (hz)		0.00071429	
tempo	cella di carico	u	LVDT
(min)	kN	(kPa)	δ (mm)
225.80	-0.075	224.6	-0.316
225.83	-0.075	224.6	-0.3169
225.87	-0.075	224.5	-0.3169
225.90	-0.076	224.5	-0.3178
225.93	-0.076	224.4	-0.3187
225.97	-0.076	224.3	-0.3187
226.00	-0.076	224.3	-0.3196
226.03	-0.077	224.2	-0.3196
226.07	-0.078	224.2	-0.3204
226.10	-0.078	224.1	-0.3213
226.13	-0.078	224.1	-0.3222
226.17	-0.078	224	-0.3222
226.20	-0.078	224	-0.3231
226.23	-0.079	223.9	-0.324
226.27	-0.08	223.8	-0.324
226.30	-0.079	223.8	-0.324
226.33	-0.079	223.8	-0.3249
226.37	-0.08	223.7	-0.3249
226.40	-0.08	223.7	-0.3258
226.43	-0.08	223.6	-0.3258
226.47	-0.081	223.6	-0.3267
226.50	-0.081	223.5	-0.3267
226.53	-0.081	223.5	-0.3267
226.57	-0.081	223.5	-0.3275
226.60	-0.081	223.4	-0.3275
226.65	-0.082	223.4	-0.3284
226.68	-0.082	223.3	-0.3293
226.70	-0.082	223.3	-0.3293
226.73	-0.082	223.2	-0.3302
226.77	-0.082	223.2	-0.3302
226.80	-0.083	223.1	-0.3311
226.83	-0.083	223.1	-0.3311
226.87	-0.082	223.1	-0.3311
226.90	-0.082	223.1	-0.3311
226.93	-0.083	223	-0.332
226.97	-0.084	222.9	-0.3329
227.00	-0.083	222.9	-0.3329
227.03	-0.083	222.9	-0.3329
227.07	-0.084	222.8	-0.3329
227.10	-0.083	222.8	-0.3329
227.13	-0.083	222.8	-0.3329
227.17	-0.084	222.8	-0.3338
227.20	-0.084	222.7	-0.3346
227.23	-0.084	222.7	-0.3346
227.27	-0.084	222.7	-0.3346
227.30	-0.084	222.7	-0.3346
227.33	-0.085	222.7	-0.3346
227.37	-0.085	222.6	-0.3355
227.40	-0.084	222.6	-0.3355
227.43	-0.084	222.6	-0.3355
227.47	-0.084	222.5	-0.3355
227.50	-0.085	222.5	-0.3364
227.53	-0.085	222.5	-0.3364
227.57	-0.084	222.5	-0.3364
227.60	-0.084	222.4	-0.3364
227.63	-0.084	222.4	-0.3364
227.67	-0.084	222.4	-0.3364
227.70	-0.084	222.4	-0.3373

Prova triassiale ciclica SNME01-C3			
pressione di confinamento (kPa)		380	
deviatore ciclico (kPa)		80	
frequenza (hz)		0.00071429	
tempo	cella di carico	u	LVDT
(min)	kN	(kPa)	δ (mm)
227.73	-0.084	222.4	-0.3373
227.77	-0.084	222.3	-0.3373
227.80	-0.084	222.3	-0.3373
227.83	-0.084	222.3	-0.3373
227.87	-0.084	222.3	-0.3373
227.90	-0.084	222.3	-0.3373
227.93	-0.084	222.3	-0.3382
227.97	-0.084	222.3	-0.3382
228.00	-0.083	222.3	-0.3382
228.03	-0.083	222.3	-0.3382
228.08	-0.083	222.2	-0.3382
228.12	-0.083	222.2	-0.3382
228.13	-0.083	222.2	-0.3382
228.17	-0.083	222.2	-0.3382
228.20	-0.083	222.2	-0.3382
228.23	-0.083	222.2	-0.3382
228.27	-0.083	222.2	-0.3382
228.30	-0.083	222.2	-0.3382
228.33	-0.082	222.2	-0.3382
228.37	-0.082	222.2	-0.3382
228.40	-0.082	222.2	-0.3382
228.43	-0.082	222.2	-0.3382
228.47	-0.081	222.2	-0.3382
228.50	-0.081	222.2	-0.3382
228.53	-0.081	222.2	-0.3382
228.57	-0.081	222.2	-0.3382
228.60	-0.081	222.2	-0.3373
228.63	-0.081	222.2	-0.3382
228.67	-0.08	222.2	-0.3373
228.70	-0.08	222.2	-0.3373
228.73	-0.08	222.2	-0.3373
228.77	-0.079	222.2	-0.3373
228.80	-0.078	222.2	-0.3373
228.83	-0.079	222.2	-0.3373
228.87	-0.079	222.2	-0.3373
228.90	-0.079	222.2	-0.3373
228.93	-0.077	222.2	-0.3364
228.97	-0.078	222.2	-0.3364
229.00	-0.077	222.3	-0.3364
229.03	-0.077	222.3	-0.3364
229.07	-0.077	222.3	-0.3364
229.10	-0.077	222.3	-0.3364
229.13	-0.076	222.3	-0.3364
229.17	-0.076	222.3	-0.3364
229.20	-0.075	222.3	-0.3355
229.23	-0.075	222.3	-0.3355
229.27	-0.075	222.3	-0.3355
229.30	-0.074	222.3	-0.3355
229.33	-0.074	222.4	-0.3355
229.37	-0.074	222.4	-0.3346
229.40	-0.072	222.4	-0.3346
229.43	-0.073	222.4	-0.3346
229.47	-0.073	222.4	-0.3346
229.50	-0.072	222.5	-0.3346
229.55	-0.072	222.5	-0.3338
229.58	-0.071	222.5	-0.3338
229.60	-0.07	222.6	-0.3338
229.63	-0.07	222.6	-0.3329

Prova triassiale ciclica SNME01-C3			
pressione di confinamento (kPa)		380	
deviatore ciclico (kPa)		80	
frequenza (hz)		0.00071429	
tempo	cella di carico	u	LVDT
(min)	kN	(kPa)	δ (mm)
229.67	-0.07	222.6	-0.3329
229.70	-0.069	222.6	-0.3329
229.73	-0.069	222.6	-0.3329
229.77	-0.068	222.7	-0.332
229.80	-0.068	222.7	-0.332
229.83	-0.068	222.7	-0.332
229.87	-0.067	222.7	-0.332
229.90	-0.067	222.7	-0.3311
229.93	-0.066	222.8	-0.3311
229.97	-0.066	222.8	-0.3302
230.00	-0.065	222.9	-0.3302
230.03	-0.064	222.9	-0.3302
230.07	-0.064	222.9	-0.3302
230.10	-0.064	222.9	-0.3293
230.13	-0.064	223	-0.3293
230.17	-0.063	223	-0.3284
230.20	-0.062	223	-0.3284
230.23	-0.061	223.1	-0.3275
230.27	-0.061	223.1	-0.3275
230.30	-0.061	223.1	-0.3275
230.33	-0.06	223.1	-0.3275
230.37	-0.06	223.2	-0.3267
230.40	-0.059	223.3	-0.3258
230.43	-0.058	223.3	-0.3258
230.47	-0.058	223.4	-0.3249
230.50	-0.057	223.4	-0.324
230.53	-0.056	223.5	-0.324
230.57	-0.055	223.5	-0.324
230.60	-0.055	223.5	-0.3231
230.63	-0.055	223.6	-0.3231
230.67	-0.054	223.6	-0.3222
230.70	-0.054	223.6	-0.3222
230.73	-0.053	223.7	-0.3213
230.77	-0.052	223.8	-0.3213
230.80	-0.051	223.8	-0.3204
230.83	-0.051	223.8	-0.3196
230.87	-0.051	223.9	-0.3196
230.90	-0.05	223.9	-0.3187
230.93	-0.049	224	-0.3178
230.97	-0.049	224.1	-0.3169
231.02	-0.048	224.1	-0.3169
231.05	-0.047	224.2	-0.316
231.07	-0.047	224.2	-0.316
231.10	-0.045	224.3	-0.316
231.13	-0.045	224.3	-0.3142
231.17	-0.045	224.3	-0.3142
231.20	-0.045	224.4	-0.3133
231.23	-0.042	224.6	-0.3116
231.27	-0.043	224.6	-0.3116
231.30	-0.042	224.6	-0.3107
231.33	-0.041	224.8	-0.3107
231.37	-0.039	224.8	-0.3098
231.40	-0.039	224.9	-0.308
231.43	-0.039	224.9	-0.308
231.47	-0.039	225	-0.3071
231.50	-0.038	225	-0.3053
231.53	-0.037	225.2	-0.3036
231.57	-0.035	225.3	-0.3036

Prova triassiale ciclica SNME01-C3			
pressione di confinamento (kPa)		380	
deviatore ciclico (kPa)		80	
frequenza (hz)		0.00071429	
tempo	cella di carico	u	LVDT
(min)	kN	(kPa)	δ (mm)
231.60	-0.035	225.3	-0.3018
231.63	-0.035	225.3	-0.3009
231.67	-0.035	225.4	-0.2991
231.70	-0.033	225.5	-0.2974
231.73	-0.032	225.6	-0.2965
231.77	-0.031	225.7	-0.2947
231.80	-0.031	225.7	-0.2947
231.83	-0.03	225.7	-0.2938
231.87	-0.03	225.8	-0.292
231.90	-0.03	225.9	-0.2903
231.93	-0.028	226	-0.2885
231.97	-0.028	226.1	-0.2867
232.00	-0.027	226.2	-0.284
232.03	-0.025	226.3	-0.284
232.07	-0.024	226.3	-0.2823
232.10	-0.024	226.4	-0.2805
232.13	-0.024	226.4	-0.2787
232.17	-0.023	226.6	-0.2769
232.20	-0.022	226.6	-0.2761
232.23	-0.022	226.8	-0.2734
232.27	-0.02	226.9	-0.2734
232.30	-0.019	226.9	-0.2716
232.33	-0.019	227	-0.2698
232.37	-0.019	227	-0.2681
232.40	-0.017	227.2	-0.2654
232.45	-0.017	227.3	-0.2636
232.48	-0.016	227.4	-0.261
232.50	-0.015	227.4	-0.2601
232.53	-0.015	227.5	-0.2574
232.57	-0.014	227.7	-0.2539
232.60	-0.012	227.8	-0.2539
232.63	-0.011	227.8	-0.2512
232.67	-0.011	227.9	-0.2494
232.70	-0.011	228	-0.2468
232.73	-0.009	228.1	-0.2441
232.77	-0.009	228.2	-0.2423
232.80	-0.008	228.3	-0.2388
232.83	-0.006	228.5	-0.2388
232.87	-0.006	228.5	-0.2352
232.90	-0.006	228.5	-0.2326
232.93	-0.005	228.6	-0.2299
232.97	-0.003	228.8	-0.2263
233.00	-0.004	228.8	-0.2237
233.03	-0.003	229	-0.2201
233.07	-0.001	229.2	-0.2201
233.10	-0.001	229.2	-0.2157
233.13	-0.001	229.3	-0.213
233.17	0	229.4	-0.2068
233.20	0.003	229.6	-0.2024
233.23	0.002	229.6	-0.1979
233.27	0.002	229.7	-0.1944
233.30	0.005	230	-0.1944
233.33	0.005	230	-0.19
233.37	0.005	230	-0.1855
233.40	0.007	230.2	-0.1829
233.43	0.007	230.2	-0.1811
233.47	0.008	230.3	-0.1775
233.50	0.009	230.5	-0.1713

Prova triassiale ciclica SNME01-C3			
pressione di confinamento (kPa)		380	
deviatore ciclico (kPa)		80	
frequenza (hz)		0.00071429	
tempo	cella di carico	u	LVDT
(min)	kN	(kPa)	δ (mm)
233.53	0.01	230.7	-0.1713
233.57	0.011	230.7	-0.166
233.60	0.011	230.8	-0.1607
233.63	0.011	230.9	-0.1553
233.67	0.014	231.1	-0.15
233.70	0.014	231.2	-0.1456
233.73	0.015	231.3	-0.1402
233.77	0.016	231.4	-0.1402
233.80	0.016	231.4	-0.1358
233.83	0.016	231.5	-0.1314
233.87	0.017	231.6	-0.1269
233.92	0.02	231.8	-0.1216
233.95	0.02	231.9	-0.1172
233.97	0.019	231.9	-0.1136
234.00	0.021	232.1	-0.1092
234.03	0.022	232.2	-0.1047
234.07	0.023	232.3	-0.1003
234.10	0.024	232.4	-0.1003
234.13	0.024	232.4	-0.0968
234.17	0.024	232.6	-0.0932
234.20	0.025	232.7	-0.0888
234.23	0.027	232.8	-0.0843
234.27	0.028	232.9	-0.0808
234.30	0.028	233	-0.0772
234.33	0.029	233.1	-0.0772
234.37	0.031	233.1	-0.0737
234.40	0.031	233.3	-0.0701
234.43	0.03	233.3	-0.0683
234.47	0.032	233.4	-0.0648
234.50	0.032	233.4	-0.063
234.53	0.034	233.5	-0.0604
234.57	0.035	233.6	-0.0604
234.60	0.036	233.6	-0.0586
234.63	0.036	233.7	-0.0559
234.67	0.036	233.7	-0.055
234.70	0.037	233.8	-0.0533
234.73	0.039	233.9	-0.0515
234.77	0.038	234	-0.0506
234.80	0.04	234.1	-0.0506
234.83	0.04	234.1	-0.0488
234.87	0.04	234.1	-0.047
234.90	0.042	234.2	-0.0453
234.93	0.043	234.3	-0.0444
234.97	0.043	234.3	-0.0435
235.00	0.045	234.4	-0.0417
235.03	0.045	234.5	-0.0417
235.07	0.045	234.5	-0.0408
235.10	0.045	234.5	-0.0399
235.13	0.046	234.6	-0.0382
235.17	0.048	234.7	-0.0373
235.20	0.049	234.8	-0.0364
235.23	0.05	234.9	-0.0346
235.27	0.05	234.9	-0.0346
235.30	0.051	234.9	-0.0337
235.35	0.051	235.1	-0.032
235.38	0.052	235.1	-0.032
235.40	0.053	235.1	-0.0311
235.43	0.053	235.2	-0.0293

Prova triassiale ciclica SNME01-C3			
pressione di confinamento (kPa)		380	
deviatore ciclico (kPa)		80	
frequenza (hz)		0.00071429	
tempo	cella di carico	u	LVDT
(min)	kN	(kPa)	δ (mm)
235.47	0.054	235.3	-0.0284
235.50	0.055	235.4	-0.0275
235.53	0.055	235.4	-0.0257
235.57	0.056	235.5	-0.0249
235.60	0.057	235.6	-0.0249
235.63	0.059	235.6	-0.024
235.67	0.059	235.7	-0.0222
235.70	0.058	235.8	-0.0213
235.73	0.059	235.8	-0.0204
235.77	0.061	236	-0.0195
235.80	0.061	236	-0.0186
235.83	0.062	236.1	-0.0186
235.87	0.061	236.1	-0.0178
235.90	0.061	236.1	-0.0169
235.93	0.062	236.2	-0.016
235.97	0.064	236.3	-0.0142
236.00	0.065	236.4	-0.0133
236.03	0.067	236.5	-0.0115
236.07	0.064	236.5	-0.0115
236.10	0.067	236.5	-0.0115
236.13	0.067	236.6	-0.0098
236.17	0.067	236.7	-0.0089
236.20	0.069	236.7	-0.008
236.23	0.068	236.8	-0.0071
236.27	0.068	236.9	-0.0062
236.30	0.07	236.9	-0.0062
236.33	0.071	236.9	-0.0053
236.37	0.071	237	-0.0044
236.40	0.071	237.1	-0.0027
236.43	0.073	237.2	-0.0018
236.47	0.073	237.2	-0.0009
236.50	0.075	237.4	0
236.53	0.073	237.4	0
236.57	0.074	237.4	0
236.60	0.074	237.5	0.0018
236.63	0.078	237.7	0.0036
236.67	0.074	237.6	0.0036
236.70	0.075	237.7	0.0044
236.73	0.077	237.8	0.0053
236.77	0.078	237.9	0.0053
236.82	0.078	237.9	0.0071
236.85	0.078	238	0.0071
236.87	0.08	238	0.0071
236.90	0.079	238	0.008
236.93	0.079	238.1	0.0089
236.97	0.08	238.1	0.0098
237.00	0.081	238.2	0.0098
237.03	0.081	238.3	0.0107
237.07	0.082	238.3	0.0115
237.10	0.082	238.4	0.0115
237.13	0.082	238.4	0.0124
237.17	0.082	238.5	0.0133
237.20	0.083	238.6	0.0142
237.23	0.084	238.7	0.0151
237.27	0.084	238.7	0.0151
237.30	0.084	238.8	0.016
237.33	0.085	238.8	0.016
237.37	0.086	238.8	0.0169

Prova triassiale ciclica SNME01-C3			
pressione di confinamento (kPa)		380	
deviatore ciclico (kPa)		80	
frequenza (hz)		0.00071429	
tempo	cella di carico	u	LVDT
(min)	kN	(kPa)	δ (mm)
237.40	0.086	238.9	0.0169
237.43	0.086	238.9	0.0178
237.47	0.086	239	0.0186
237.50	0.087	239.1	0.0186
237.53	0.087	239.1	0.0195
237.57	0.087	239.2	0.0195
237.60	0.088	239.2	0.0204
237.63	0.088	239.2	0.0213
237.67	0.089	239.3	0.0222
237.70	0.09	239.4	0.0231
237.73	0.089	239.4	0.0231
237.77	0.088	239.4	0.0231
237.80	0.091	239.6	0.0231
237.83	0.091	239.6	0.0249
237.87	0.091	239.6	0.0249
237.90	0.09	239.6	0.0249
237.93	0.088	239.6	0.0249
237.97	0.092	239.7	0.0266
238.00	0.092	239.8	0.0266
238.03	0.092	239.8	0.0266
238.07	0.092	239.8	0.0266
238.10	0.092	239.9	0.0275
238.13	0.092	239.9	0.0275
238.17	0.092	240	0.0284
238.20	0.092	240	0.0284
238.25	0.093	240.1	0.0293
238.28	0.094	240.1	0.0293
238.30	0.091	240.1	0.0293
238.33	0.095	240.3	0.0311
238.37	0.096	240.3	0.0311
238.40	0.093	240.3	0.0311
238.43	0.093	240.2	0.0302
238.47	0.095	240.4	0.032
238.50	0.095	240.4	0.032
238.53	0.095	240.4	0.032
238.57	0.094	240.4	0.032
238.60	0.093	240.4	0.032
238.63	0.097	240.4	0.032
238.67	0.097	240.6	0.0328
238.70	0.093	240.5	0.0328
238.73	0.096	240.6	0.0337
238.77	0.094	240.6	0.0337
238.80	0.097	240.7	0.0346
238.83	0.097	240.7	0.0346
238.87	0.093	240.7	0.0346
238.90	0.093	240.7	0.0346
238.93	0.097	240.8	0.0355
238.97	0.097	240.9	0.0355
239.00	0.096	240.9	0.0355
239.03	0.096	240.9	0.0355
239.07	0.096	240.9	0.0355
239.10	0.096	240.9	0.0355
239.13	0.096	240.9	0.0355
239.17	0.096	241	0.0355
239.20	0.096	241	0.0355
239.23	0.096	241	0.0355
239.27	0.096	241	0.0364
239.30	0.096	241.1	0.0364

Prova triassiale ciclica SNME01-C3			
pressione di confinamento (kPa)		380	
deviatore ciclico (kPa)		80	
frequenza (hz)		0.00071429	
tempo	cella di carico	u	LVDT
(min)	kN	(kPa)	δ (mm)
239.33	0.096	241.1	0.0364
239.37	0.096	241.1	0.0364
239.40	0.096	241.1	0.0364
239.43	0.096	241.1	0.0364
239.47	0.095	241.1	0.0364
239.50	0.096	241.2	0.0364
239.53	0.095	241.2	0.0364
239.57	0.096	241.2	0.0364
239.60	0.096	241.2	0.0364
239.63	0.096	241.2	0.0364
239.67	0.095	241.3	0.0364
239.72	0.092	241.2	0.0364
239.75	0.096	241.3	0.0373
239.77	0.096	241.4	0.0373
239.80	0.092	241.2	0.0364
239.83	0.094	241.4	0.0373
239.87	0.098	241.5	0.0373
239.90	0.095	241.4	0.0382
239.93	0.095	241.4	0.0373
239.97	0.095	241.4	0.0373
240.00	0.094	241.4	0.0373
240.03	0.094	241.4	0.0373
240.07	0.094	241.4	0.0373
240.10	0.093	241.4	0.0373
240.13	0.093	241.4	0.0373
240.17	0.093	241.4	0.0373
240.20	0.093	241.5	0.0373
240.23	0.093	241.5	0.0373
240.27	0.092	241.5	0.0364
240.30	0.092	241.5	0.0364
240.33	0.092	241.5	0.0364
240.37	0.092	241.5	0.0364
240.40	0.092	241.5	0.0364
240.43	0.091	241.5	0.0364
240.47	0.091	241.5	0.0364
240.50	0.09	241.5	0.0364
240.53	0.09	241.5	0.0364
240.57	0.09	241.5	0.0364
240.60	0.089	241.5	0.0364
240.63	0.089	241.5	0.0364
240.67	0.089	241.6	0.0355
240.70	0.089	241.5	0.0355
240.73	0.088	241.5	0.0346
240.77	0.087	241.5	0.0355
240.80	0.089	241.6	0.0355
240.83	0.087	241.5	0.0355
240.87	0.087	241.5	0.0355
240.90	0.087	241.5	0.0355
240.93	0.087	241.5	0.0355
240.97	0.083	241.4	0.0346
241.00	0.086	241.5	0.0355
241.03	0.087	241.6	0.0355
241.07	0.085	241.5	0.0355
241.10	0.085	241.5	0.0346
241.13	0.085	241.5	0.0346
241.18	0.083	241.4	0.0337
241.22	0.083	241.4	0.0337
241.23	0.083	241.4	0.0337

Prova triassiale ciclica SNME01-C3			
pressione di confinamento (kPa)		380	
deviatore ciclico (kPa)		80	
frequenza (hz)		0.00071429	
tempo	cella di carico	u	LVDT
(min)	kN	(kPa)	δ (mm)
241.27	0.082	241.4	0.0337
241.30	0.082	241.4	0.0337
241.33	0.081	241.4	0.0328
241.37	0.078	241.3	0.0328
241.40	0.082	241.4	0.032
241.43	0.082	241.4	0.0328
241.47	0.081	241.4	0.0328
241.50	0.079	241.3	0.032
241.53	0.078	241.3	0.032
241.57	0.078	241.3	0.032
241.60	0.078	241.3	0.032
241.63	0.077	241.2	0.032
241.67	0.077	241.2	0.0302
241.70	0.072	241.1	0.0302
241.73	0.077	241.3	0.0311
241.77	0.077	241.3	0.0311
241.80	0.075	241.2	0.0302
241.83	0.073	241.1	0.0302
241.87	0.07	241	0.0293
241.90	0.07	241	0.0284
241.93	0.071	241.1	0.0293
241.97	0.074	241.2	0.0302
242.00	0.074	241.1	0.0293
242.03	0.071	241	0.0275
242.07	0.069	241	0.0275
242.10	0.067	240.9	0.0266
242.13	0.067	240.9	0.0266
242.17	0.068	240.9	0.0266
242.20	0.069	240.9	0.0266
242.23	0.07	241	0.0257
242.27	0.065	240.8	0.0249
242.30	0.063	240.7	0.0249
242.33	0.067	240.8	0.0249
242.37	0.067	240.8	0.0249
242.40	0.067	240.8	0.0249
242.43	0.064	240.7	0.0231
242.47	0.059	240.6	0.0222
242.50	0.063	240.7	0.0231
242.53	0.064	240.7	0.0231
242.57	0.061	240.6	0.0231
242.62	0.06	240.5	0.0213
242.65	0.06	240.5	0.0213
242.67	0.059	240.5	0.0204
242.70	0.059	240.5	0.0204
242.73	0.058	240.5	0.0195
242.77	0.058	240.4	0.0195
242.80	0.057	240.4	0.0186
242.83	0.056	240.3	0.0178
242.87	0.054	240.3	0.0178
242.90	0.054	240.2	0.0169
242.93	0.054	240.2	0.0169
242.97	0.054	240.2	0.016
243.00	0.053	240.2	0.0151
243.03	0.052	240.1	0.0151
243.07	0.051	240.1	0.0142
243.10	0.05	240	0.0142
243.13	0.049	239.9	0.0133
243.17	0.049	239.9	0.0124

Prova triassiale ciclica SNME01-C3			
ensione di confinamento (kPa)		380	
deviatore ciclico (kPa)		80	
frequenza (hz)		0.00071429	
tempo	cella di carico	u	LVDT
(min)	kN	(kPa)	δ (mm)
243.20	0.049	239.9	0.0115
243.23	0.048	239.9	0.0107
243.27	0.047	239.8	0.0107
243.30	0.046	239.8	0.0089
243.33	0.045	239.7	0.0089
243.37	0.044	239.6	0.0089
243.40	0.044	239.6	0.008
243.43	0.044	239.6	0.0071
243.47	0.043	239.5	0.0062
243.50	0.042	239.5	0.0053
243.53	0.041	239.4	0.0044
243.57	0.04	239.4	0.0044
243.60	0.039	239.3	0.0036
243.63	0.039	239.3	0.0027
243.67	0.039	239.3	0.0018
243.70	0.037	239.2	0.0009
243.73	0.037	239.1	0
243.77	0.035	239.1	-0.0009
243.80	0.034	239	-0.0009
243.83	0.034	239	-0.0018
243.87	0.034	239	-0.0027
243.90	0.033	238.9	-0.0036
243.93	0.032	238.8	-0.0053
243.97	0.031	238.8	-0.0053
244.00	0.031	238.7	-0.0071
244.03	0.029	238.7	-0.0071
244.08	0.029	238.6	-0.0089
244.12	0.028	238.6	-0.0098
244.13	0.027	238.5	-0.0098
244.17	0.026	238.4	-0.0107
244.20	0.026	238.4	-0.0115
244.23	0.025	238.3	-0.0133
244.27	0.025	238.3	-0.0142
244.30	0.023	238.2	-0.0151
244.33	0.023	238.1	-0.016
244.37	0.021	238	-0.016
244.40	0.02	238	-0.0178
244.43	0.02	238	-0.0186
244.47	0.02	237.9	-0.0195
244.50	0.019	237.8	-0.0204
244.53	0.018	237.8	-0.0222
244.57	0.017	237.7	-0.0231
244.60	0.015	237.6	-0.0231
244.63	0.015	237.5	-0.024
244.67	0.015	237.5	-0.0257
244.70	0.014	237.5	-0.0266
244.73	0.013	237.4	-0.0275
244.77	0.012	237.3	-0.0293
244.80	0.011	237.2	-0.0302
244.83	0.01	237.1	-0.0302
244.87	0.009	237	-0.032
244.90	0.009	237	-0.0328
244.93	0.009	237	-0.0337
244.97	0.007	236.9	-0.0355
245.00	0.006	236.8	-0.0364
245.03	0.006	236.8	-0.0373
245.07	0.005	236.7	-0.0373
245.10	0.003	236.6	-0.0382

Prova triassiale ciclica SNME01-C3			
pressione di confinamento (kPa)		380	
deviatore ciclico (kPa)		80	
frequenza (hz)		0.00071429	
tempo	cella di carico	u	LVDT
(min)	kN	(kPa)	δ (mm)
245.13	0.003	236.6	-0.0399
245.17	0.003	236.5	-0.0408
245.20	0.002	236.4	-0.0426
245.23	0	236.3	-0.0435
245.27	0	236.3	-0.0444
245.30	-0.001	236.2	-0.0444
245.33	-0.002	236.1	-0.0462
245.37	-0.002	236.1	-0.047
245.40	-0.003	236	-0.0488
245.43	-0.004	235.9	-0.0497
245.47	-0.005	235.8	-0.0515
245.52	-0.006	235.8	-0.0524
245.55	-0.007	235.7	-0.0541
245.57	-0.006	235.7	-0.055
245.60	-0.008	235.6	-0.0586
245.63	-0.009	235.4	-0.0586
245.67	-0.01	235.3	-0.0612
245.70	-0.01	235.3	-0.0648
245.73	-0.011	235.2	-0.0683
245.77	-0.012	235.1	-0.071
245.80	-0.013	235	-0.0737
245.83	-0.014	234.8	-0.0772
245.87	-0.015	234.7	-0.0772
245.90	-0.016	234.6	-0.0817
245.93	-0.016	234.6	-0.0852
245.97	-0.016	234.5	-0.0897
246.00	-0.018	234.4	-0.0941
246.03	-0.018	234.3	-0.0985
246.07	-0.019	234.2	-0.1047
246.10	-0.02	234.1	-0.1047
246.13	-0.021	233.9	-0.1127
246.17	-0.021	233.9	-0.1225
246.20	-0.022	233.8	-0.1349
246.23	-0.022	233.6	-0.15
246.27	-0.024	233.3	-0.166
246.30	-0.024	233.2	-0.174
246.33	-0.026	232.9	-0.174
246.37	-0.026	232.8	-0.182
246.40	-0.026	232.8	-0.1864
246.43	-0.027	232.7	-0.1926
246.47	-0.029	232.5	-0.1962
246.50	-0.029	232.4	-0.1997
246.53	-0.03	232.3	-0.2033
246.57	-0.031	232.1	-0.2033
246.60	-0.032	232	-0.2059
246.63	-0.032	232	-0.2077
246.67	-0.032	232	-0.2086
246.70	-0.033	231.8	-0.2104
246.73	-0.034	231.7	-0.2113
246.77	-0.035	231.7	-0.213
246.80	-0.036	231.5	-0.213
246.83	-0.037	231.3	-0.2201
246.87	-0.037	231.3	-0.2237
246.90	-0.038	231.2	-0.2281
246.93	-0.038	231.1	-0.2308
246.98	-0.04	230.9	-0.2334
247.02	-0.04	230.8	-0.2352
247.03	-0.04	230.7	-0.2379

Prova triassiale ciclica SNME01-C3			
pressione di confinamento (kPa)		380	
deviatore ciclico (kPa)		80	
frequenza (hz)		0.00071429	
tempo	cella di carico	u	LVDT
(min)	kN	(kPa)	δ (mm)
247.07	-0.041	230.6	-0.2397
247.10	-0.042	230.5	-0.2423
247.13	-0.043	230.4	-0.2423
247.17	-0.044	230.2	-0.245
247.20	-0.044	230.2	-0.2477
247.23	-0.044	230.2	-0.2494
247.27	-0.045	230	-0.2512
247.30	-0.046	229.9	-0.2539
247.33	-0.047	229.8	-0.2556
247.37	-0.048	229.6	-0.2556
247.40	-0.047	229.6	-0.2574
247.43	-0.047	229.6	-0.2583
247.47	-0.049	229.5	-0.261
247.50	-0.05	229.3	-0.2627
247.53	-0.051	229.2	-0.2645
247.57	-0.051	229.1	-0.2663
247.60	-0.052	229	-0.2663
247.63	-0.053	228.9	-0.2681
247.67	-0.053	228.9	-0.2698
247.70	-0.053	228.8	-0.2716
247.73	-0.054	228.7	-0.2734
247.77	-0.055	228.6	-0.2743
247.80	-0.055	228.5	-0.2761
247.83	-0.056	228.4	-0.2761
247.87	-0.057	228.3	-0.2778
247.90	-0.057	228.3	-0.2787
247.93	-0.057	228.2	-0.2805
247.97	-0.059	228	-0.2823
248.00	-0.059	228	-0.2832
248.03	-0.059	227.9	-0.284
248.07	-0.06	227.8	-0.284
248.10	-0.061	227.7	-0.2867
248.13	-0.061	227.7	-0.2885
248.17	-0.061	227.6	-0.2894
248.20	-0.062	227.5	-0.2911
248.23	-0.063	227.4	-0.292
248.27	-0.063	227.4	-0.2929
248.30	-0.064	227.2	-0.2929
248.33	-0.064	227.2	-0.2938
248.37	-0.064	227.2	-0.2947
248.40	-0.065	227.1	-0.2965
248.45	-0.066	226.9	-0.2982
248.47	-0.066	226.9	-0.2991
248.50	-0.067	226.8	-0.3
248.53	-0.067	226.7	-0.3009
248.57	-0.067	226.6	-0.3018
248.60	-0.068	226.5	-0.3027
248.63	-0.068	226.4	-0.3027
248.67	-0.07	226.3	-0.3045
248.70	-0.07	226.3	-0.3053
248.73	-0.07	226.3	-0.3062
248.77	-0.07	226.2	-0.3071
248.80	-0.071	226.1	-0.308
248.83	-0.071	226	-0.3089
248.87	-0.071	226	-0.3089
248.90	-0.072	225.9	-0.3098
248.93	-0.072	225.9	-0.3107
248.97	-0.073	225.8	-0.3116

Prova triassiale ciclica SNME01-C3			
pressione di confinamento (kPa)		380	
deviatore ciclico (kPa)		80	
frequenza (hz)		0.00071429	
tempo	cella di carico	u	LVDT
(min)	kN	(kPa)	δ (mm)
249.00	-0.073	225.7	-0.3124
249.03	-0.073	225.7	-0.3124
249.07	-0.074	225.6	-0.3142
249.10	-0.074	225.5	-0.3142
249.13	-0.075	225.5	-0.3142
249.17	-0.075	225.5	-0.3151
249.20	-0.075	225.4	-0.316
249.23	-0.075	225.3	-0.3169
249.27	-0.077	225.2	-0.3178
249.30	-0.076	225.2	-0.3178
249.33	-0.076	225.2	-0.3178
249.37	-0.078	225.1	-0.3187
249.40	-0.078	225.1	-0.3196
249.43	-0.078	225	-0.3196
249.47	-0.077	225	-0.3204
249.50	-0.079	224.9	-0.3213
249.53	-0.078	224.9	-0.3213
249.57	-0.079	224.8	-0.3213
249.60	-0.079	224.7	-0.3222
249.63	-0.079	224.7	-0.3231
249.67	-0.079	224.6	-0.3231
249.70	-0.08	224.5	-0.324
249.73	-0.08	224.5	-0.324
249.77	-0.081	224.5	-0.3249
249.80	-0.08	224.4	-0.3249
249.83	-0.081	224.4	-0.3249
249.88	-0.081	224.3	-0.3258
249.92	-0.081	224.3	-0.3258
249.93	-0.081	224.2	-0.3267
249.97	-0.081	224.2	-0.3267
250.00	-0.082	224.1	-0.3275
250.03	-0.082	224.1	-0.3275
250.07	-0.082	224.1	-0.3284
250.10	-0.083	224	-0.3293
250.13	-0.083	224	-0.3293
250.17	-0.082	223.9	-0.3293
250.20	-0.082	223.9	-0.3293
250.23	-0.083	223.9	-0.3302
250.27	-0.084	223.8	-0.3311
250.30	-0.083	223.8	-0.3311
250.33	-0.083	223.8	-0.3311
250.37	-0.084	223.7	-0.3311
250.40	-0.084	223.7	-0.3311
250.43	-0.084	223.7	-0.332
250.47	-0.084	223.7	-0.332
250.50	-0.084	223.6	-0.3329
250.53	-0.084	223.6	-0.3329
250.57	-0.084	223.5	-0.3329
250.60	-0.084	223.5	-0.3329
250.63	-0.084	223.5	-0.3329
250.67	-0.084	223.5	-0.3338
250.70	-0.084	223.5	-0.3338
250.73	-0.084	223.4	-0.3338
250.77	-0.084	223.4	-0.3338
250.80	-0.084	223.4	-0.3346
250.83	-0.084	223.3	-0.3346
250.87	-0.084	223.3	-0.3346
250.90	-0.084	223.3	-0.3346

Prova triassiale ciclica SNME01-C3			
pressione di confinamento (kPa)		380	
deviatore ciclico (kPa)		80	
frequenza (hz)		0.00071429	
tempo	cella di carico	u	LVDT
(min)	kN	(kPa)	δ (mm)
250.93	-0.084	223.3	-0.3346
250.97	-0.084	223.3	-0.3355
251.00	-0.084	223.2	-0.3355
251.03	-0.084	223.2	-0.3355
251.07	-0.084	223.2	-0.3355
251.10	-0.084	223.2	-0.3355
251.13	-0.084	223.2	-0.3355
251.17	-0.084	223.2	-0.3355
251.20	-0.084	223.1	-0.3355
251.23	-0.084	223.1	-0.3355
251.27	-0.083	223.1	-0.3355
251.30	-0.083	223.1	-0.3355
251.35	-0.083	223.1	-0.3364
251.38	-0.083	223.1	-0.3364
251.40	-0.084	223.1	-0.3364
251.43	-0.083	223.1	-0.3364
251.47	-0.083	223.1	-0.3364
251.50	-0.083	223	-0.3364
251.53	-0.083	223	-0.3364
251.57	-0.083	223	-0.3364
251.60	-0.083	223	-0.3364
251.63	-0.082	223	-0.3364
251.67	-0.082	223	-0.3364
251.70	-0.082	223	-0.3364
251.73	-0.082	223	-0.3364
251.77	-0.082	223	-0.3364
251.80	-0.082	223	-0.3364
251.83	-0.081	223	-0.3355
251.87	-0.081	223	-0.3355
251.90	-0.081	223	-0.3355
251.93	-0.081	223	-0.3355
251.97	-0.08	223	-0.3355
252.00	-0.08	223	-0.3355
252.03	-0.08	223	-0.3355
252.07	-0.08	223	-0.3355
252.10	-0.079	223	-0.3355
252.13	-0.079	223	-0.3355
252.17	-0.079	223	-0.3355
252.20	-0.078	223.1	-0.3355
252.23	-0.078	223.1	-0.3346
252.27	-0.078	223.1	-0.3346
252.30	-0.077	223.1	-0.3346
252.33	-0.077	223.1	-0.3346
252.37	-0.077	223.1	-0.3346
252.40	-0.077	223.1	-0.3346
252.43	-0.076	223.1	-0.3346
252.47	-0.076	223.1	-0.3346
252.50	-0.075	223.1	-0.3338
252.53	-0.075	223.2	-0.3338
252.57	-0.075	223.2	-0.3338
252.60	-0.074	223.2	-0.3338
252.63	-0.074	223.2	-0.3338
252.67	-0.074	223.2	-0.3338
252.70	-0.074	223.2	-0.3329
252.73	-0.073	223.3	-0.3329
252.78	-0.073	223.3	-0.3329
252.82	-0.073	223.3	-0.3329
252.83	-0.072	223.3	-0.332

Prova triassiale ciclica SNME01-C3			
pressione di confinamento (kPa)		380	
deviatore ciclico (kPa)		80	
frequenza (hz)		0.00071429	
tempo	cella di carico	u	LVDT
(min)	kN	(kPa)	δ (mm)
252.87	-0.071	223.3	-0.332
252.90	-0.071	223.4	-0.332
252.93	-0.071	223.4	-0.332
252.97	-0.071	223.4	-0.332
253.00	-0.07	223.4	-0.3311
253.03	-0.069	223.5	-0.3311
253.07	-0.069	223.5	-0.3302
253.10	-0.068	223.5	-0.3302
253.13	-0.068	223.5	-0.3302
253.17	-0.067	223.6	-0.3302
253.20	-0.067	223.6	-0.3293
253.23	-0.067	223.6	-0.3293
253.27	-0.066	223.6	-0.3293
253.30	-0.065	223.7	-0.3284
253.33	-0.065	223.7	-0.3284
253.37	-0.065	223.7	-0.3275
253.40	-0.063	223.8	-0.3275
253.43	-0.063	223.8	-0.3275
253.47	-0.064	223.8	-0.3275
253.50	-0.063	223.8	-0.3267
253.53	-0.062	223.9	-0.3267
253.57	-0.062	223.9	-0.3258
253.60	-0.061	224	-0.3258
253.63	-0.06	224	-0.3258
253.67	-0.06	224	-0.3249
253.70	-0.06	224	-0.3249
253.73	-0.059	224.1	-0.324
253.77	-0.058	224.2	-0.3231
253.80	-0.058	224.2	-0.3231
253.83	-0.057	224.3	-0.3222
253.87	-0.056	224.3	-0.3222
253.90	-0.056	224.3	-0.3222
253.93	-0.056	224.4	-0.3213
253.97	-0.055	224.5	-0.3204
254.00	-0.054	224.5	-0.3204
254.03	-0.053	224.5	-0.3196
254.07	-0.053	224.6	-0.3187
254.10	-0.051	224.7	-0.3187
254.13	-0.051	224.7	-0.3178
254.17	-0.052	224.7	-0.3178
254.20	-0.051	224.8	-0.3169
254.25	-0.049	224.9	-0.316
254.28	-0.049	224.9	-0.316
254.30	-0.049	224.9	-0.3151
254.33	-0.048	225	-0.3151
254.37	-0.047	225.1	-0.3142
254.40	-0.047	225.1	-0.3133
254.43	-0.045	225.2	-0.3133
254.47	-0.045	225.2	-0.3124
254.50	-0.045	225.3	-0.3116
254.53	-0.044	225.4	-0.3107
254.57	-0.043	225.4	-0.3098
254.60	-0.043	225.5	-0.3089
254.63	-0.042	225.6	-0.3071
254.67	-0.04	225.6	-0.3071
254.70	-0.04	225.6	-0.3062
254.73	-0.04	225.7	-0.3053
254.77	-0.039	225.8	-0.3045

Prova triassiale ciclica SNME01-C3			
pressione di confinamento (kPa)		380	
deviatore ciclico (kPa)		80	
frequenza (hz)		0.00071429	
tempo	cella di carico	u	LVDT
(min)	kN	(kPa)	δ (mm)
254.80	-0.039	225.8	-0.3027
254.83	-0.038	225.9	-0.3018
254.87	-0.037	226	-0.3
254.90	-0.035	226.1	-0.3
254.93	-0.035	226.1	-0.2991
254.97	-0.035	226.2	-0.2974
255.00	-0.035	226.3	-0.2965
255.03	-0.033	226.3	-0.2947
255.07	-0.032	226.4	-0.2938
255.10	-0.032	226.5	-0.292
255.13	-0.03	226.6	-0.292
255.17	-0.03	226.6	-0.2911
255.20	-0.03	226.7	-0.2894
255.23	-0.03	226.8	-0.2876
255.27	-0.027	226.9	-0.2858
255.30	-0.028	227	-0.284
255.33	-0.027	227.1	-0.2823
255.37	-0.025	227.2	-0.2823
255.40	-0.025	227.2	-0.2805
255.43	-0.025	227.2	-0.2796
255.47	-0.024	227.4	-0.2769
255.50	-0.022	227.5	-0.2743
255.53	-0.022	227.6	-0.2725
255.57	-0.021	227.7	-0.2707
255.60	-0.02	227.8	-0.2707
255.63	-0.02	227.8	-0.269
255.68	-0.019	227.9	-0.2654
255.72	-0.018	228	-0.2654
255.73	-0.018	228	-0.2636
255.77	-0.017	228.1	-0.261
255.80	-0.017	228.3	-0.2583
255.83	-0.014	228.4	-0.2556
255.87	-0.015	228.4	-0.2548
255.90	-0.014	228.5	-0.2521
255.93	-0.013	228.7	-0.2521
255.97	-0.013	228.7	-0.2494
256.00	-0.011	228.8	-0.2468
256.03	-0.01	229	-0.2432
256.07	-0.009	229.1	-0.2397
256.10	-0.009	229.1	-0.2379
256.13	-0.008	229.3	-0.2352
256.17	-0.007	229.4	-0.2352
256.20	-0.007	229.4	-0.2317
256.23	-0.006	229.5	-0.2281
256.27	-0.005	229.6	-0.2237
256.30	-0.004	229.7	-0.221
256.33	-0.003	229.8	-0.2184
256.37	-0.002	230	-0.2139
256.40	-0.001	230.1	-0.2139
256.43	-0.001	230.1	-0.2104
256.47	-0.001	230.2	-0.2068
256.50	0.001	230.4	-0.2024
256.53	0.002	230.5	-0.1979
256.57	0.002	230.6	-0.1935
256.60	0.003	230.7	-0.1891
256.63	0.005	230.9	-0.1891
256.67	0.005	230.9	-0.1837
256.70	0.005	231	-0.1784

Prova triassiale ciclica SNME01-C3			
pressione di confinamento (kPa)		380	
deviatore ciclico (kPa)		80	
frequenza (hz)		0.00071429	
tempo	cella di carico	u	LVDT
(min)	kN	(kPa)	δ (mm)
256.73	0.006	231.1	-0.1749
256.77	0.007	231.2	-0.1713
256.80	0.008	231.3	-0.1695
256.83	0.008	231.4	-0.166
256.87	0.011	231.6	-0.166
256.90	0.011	231.6	-0.1598
256.93	0.011	231.7	-0.1544
256.97	0.011	231.9	-0.1491
257.00	0.014	232	-0.1438
257.03	0.014	232.1	-0.1394
257.07	0.015	232.3	-0.1358
257.10	0.016	232.4	-0.1358
257.15	0.016	232.5	-0.1269
257.18	0.017	232.6	-0.1225
257.20	0.018	232.7	-0.1225
257.23	0.019	232.7	-0.1181
257.27	0.019	232.8	-0.1136
257.30	0.019	232.9	-0.1101
257.33	0.022	233	-0.1056
257.37	0.021	233.2	-0.1021
257.40	0.024	233.4	-0.0968
257.43	0.024	233.5	-0.0968
257.47	0.025	233.5	-0.0923
257.50	0.025	233.5	-0.0888
257.53	0.025	233.7	-0.0852
257.57	0.026	233.7	-0.0817
257.60	0.028	233.9	-0.0781
257.63	0.028	233.9	-0.0754
257.67	0.029	234	-0.0754
257.70	0.029	234	-0.0719
257.73	0.029	234.1	-0.0701
257.77	0.031	234.2	-0.0675
257.80	0.033	234.2	-0.0648
257.83	0.033	234.3	-0.0639
257.87	0.034	234.4	-0.0612
257.90	0.034	234.4	-0.0612
257.93	0.036	234.4	-0.0604
257.97	0.036	234.5	-0.0586
258.00	0.037	234.6	-0.0559
258.03	0.038	234.7	-0.0541
258.07	0.037	234.7	-0.0533
258.10	0.039	234.9	-0.0524
258.13	0.041	234.9	-0.0524
258.17	0.04	234.9	-0.0506
258.20	0.04	235	-0.0497
258.23	0.041	235	-0.0479
258.27	0.043	235.1	-0.047
258.30	0.043	235.2	-0.0462
258.33	0.044	235.3	-0.0444
258.37	0.046	235.4	-0.0444
258.40	0.046	235.4	-0.0435
258.43	0.046	235.4	-0.0426
258.47	0.047	235.5	-0.0408
258.50	0.048	235.6	-0.0399
258.53	0.048	235.7	-0.0382
258.57	0.05	235.8	-0.0373
258.62	0.05	235.8	-0.0364
258.65	0.05	235.9	-0.0355

Prova triassiale ciclica SNME01-C3			
pressione di confinamento (kPa)		380	
deviatore ciclico (kPa)		80	
frequenza (hz)		0.00071429	
tempo	cella di carico	u	LVDT
(min)	kN	(kPa)	δ (mm)
258.67	0.052	236	-0.0337
258.70	0.053	236.1	-0.0337
258.73	0.053	236.1	-0.0328
258.77	0.053	236.1	-0.032
258.80	0.054	236.2	-0.0311
258.83	0.055	236.3	-0.0293
258.87	0.055	236.4	-0.0284
258.90	0.056	236.4	-0.0275
258.93	0.057	236.5	-0.0275
258.97	0.058	236.5	-0.0266
259.00	0.058	236.6	-0.0257
259.03	0.058	236.7	-0.024
259.07	0.059	236.7	-0.0231
259.10	0.06	236.8	-0.0222
259.13	0.061	236.9	-0.0204
259.17	0.062	237	-0.0204
259.20	0.062	237	-0.0195
259.23	0.062	237	-0.0186
259.27	0.063	237.2	-0.0178
259.30	0.064	237.2	-0.016
259.33	0.065	237.3	-0.016
259.37	0.065	237.4	-0.0151
259.40	0.066	237.5	-0.0151
259.43	0.067	237.5	-0.0133
259.47	0.067	237.5	-0.0133
259.50	0.067	237.6	-0.0115
259.53	0.068	237.7	-0.0107
259.57	0.069	237.8	-0.0098
259.60	0.069	237.8	-0.0089
259.63	0.071	237.9	-0.0089
259.67	0.071	237.9	-0.008
259.70	0.071	238	-0.0071
259.73	0.071	238	-0.0062
259.77	0.072	238.1	-0.0053
259.80	0.073	238.2	-0.0044
259.83	0.073	238.3	-0.0036
259.87	0.073	238.3	-0.0036
259.90	0.074	238.3	-0.0027
259.93	0.074	238.4	-0.0018
259.97	0.075	238.5	-0.0009
260.00	0.076	238.6	0
260.05	0.077	238.6	0.0009
260.08	0.076	238.7	0.0018
260.10	0.078	238.8	0.0027
260.13	0.077	238.8	0.0036
260.17	0.078	238.9	0.0044
260.20	0.079	239	0.0044
260.23	0.08	239	0.0053
260.27	0.08	239	0.0053
260.30	0.08	239.1	0.0062
260.33	0.08	239.1	0.0071
260.37	0.081	239.2	0.008
260.40	0.082	239.3	0.0089
260.43	0.082	239.4	0.0089
260.47	0.083	239.4	0.0098
260.50	0.083	239.4	0.0098
260.53	0.083	239.5	0.0107
260.57	0.084	239.5	0.0115

Prova triassiale ciclica SNME01-C3			
pressione di confinamento (kPa)		380	
deviatore ciclico (kPa)		80	
frequenza (hz)		0.00071429	
tempo	cella di carico	u	LVDT
(min)	kN	(kPa)	δ (mm)
260.60	0.084	239.6	0.0124
260.63	0.084	239.7	0.0133
260.67	0.086	239.7	0.0133
260.70	0.085	239.7	0.0133
260.73	0.085	239.8	0.0142
260.77	0.086	239.9	0.0151
260.80	0.087	239.9	0.016
260.83	0.086	240	0.016
260.87	0.087	240	0.0169
260.90	0.088	240.1	0.0169
260.93	0.088	240.1	0.0178
260.97	0.088	240.1	0.0178
261.00	0.088	240.2	0.0186
261.03	0.09	240.3	0.0195
261.07	0.09	240.3	0.0195
261.10	0.089	240.3	0.0195
261.13	0.09	240.4	0.0195
261.17	0.092	240.4	0.0204
261.20	0.092	240.5	0.0213
261.23	0.088	240.4	0.0204
261.27	0.09	240.5	0.0213
261.30	0.091	240.6	0.0222
261.33	0.091	240.7	0.0231
261.37	0.092	240.7	0.0231
261.40	0.092	240.7	0.0231
261.43	0.092	240.8	0.024
261.47	0.092	240.8	0.024
261.52	0.093	240.9	0.0249
261.55	0.093	240.9	0.0249
261.57	0.093	240.9	0.0257
261.60	0.093	241	0.0257
261.63	0.093	241	0.0266
261.67	0.093	241.1	0.0266
261.70	0.094	241.1	0.0266
261.73	0.094	241.1	0.0266
261.77	0.094	241.2	0.0275
261.80	0.094	241.2	0.0275
261.83	0.094	241.2	0.0275
261.87	0.095	241.3	0.0284
261.90	0.095	241.3	0.0284
261.93	0.094	241.4	0.0284
261.97	0.095	241.4	0.0284
262.00	0.095	241.4	0.0293
262.03	0.095	241.4	0.0293
262.07	0.098	241.6	0.0302
262.10	0.094	241.5	0.0293
262.13	0.094	241.6	0.0302
262.17	0.097	241.7	0.0302
262.20	0.096	241.7	0.0311
262.23	0.096	241.7	0.0311
262.27	0.096	241.7	0.0311
262.30	0.095	241.7	0.0311
262.33	0.096	241.8	0.0311
262.37	0.095	241.8	0.0311
262.40	0.096	241.8	0.0311
262.43	0.096	241.8	0.032
262.47	0.096	241.9	0.032
262.50	0.096	241.9	0.032

Prova triassiale ciclica SNME01-C3			
pressione di confinamento (kPa)		380	
deviatore ciclico (kPa)		80	
frequenza (hz)		0.00071429	
tempo	cella di carico	u	LVDT
(min)	kN	(kPa)	δ (mm)
262.53	0.096	241.9	0.032
262.57	0.096	241.9	0.032
262.60	0.096	242	0.032
262.63	0.096	242	0.032
262.67	0.096	242	0.0328
262.70	0.096	242	0.0328
262.73	0.096	242	0.0328
262.77	0.096	242.1	0.0328
262.80	0.097	242.1	0.0328
262.83	0.096	242.1	0.0328
262.87	0.097	242.2	0.0328
262.90	0.094	242.2	0.0337
262.95	0.094	242.1	0.0328
262.98	0.095	242.2	0.0328
263.00	0.095	242.2	0.0328
263.03	0.095	242.2	0.0337
263.07	0.095	242.2	0.0337
263.10	0.095	242.3	0.0337
263.13	0.095	242.3	0.0337
263.17	0.095	242.3	0.0337
263.20	0.094	242.3	0.0337
263.23	0.094	242.3	0.0337
263.27	0.094	242.3	0.0337
263.30	0.094	242.3	0.0337
263.33	0.094	242.3	0.0337
263.37	0.094	242.4	0.0337
263.40	0.093	242.4	0.0328
263.43	0.093	242.4	0.0328
263.47	0.093	242.4	0.0337
263.50	0.093	242.4	0.0328
263.53	0.093	242.4	0.0328
263.57	0.093	242.4	0.0328
263.60	0.092	242.4	0.0328
263.63	0.092	242.4	0.0328
263.67	0.091	242.4	0.0328
263.70	0.091	242.4	0.0328
263.73	0.091	242.4	0.0328
263.77	0.091	242.4	0.0328
263.80	0.09	242.4	0.0328
263.83	0.091	242.4	0.0328
263.87	0.09	242.4	0.0328
263.90	0.09	242.5	0.0328
263.93	0.09	242.5	0.0328
263.97	0.09	242.5	0.032
264.00	0.089	242.4	0.0328
264.03	0.088	242.4	0.032
264.07	0.088	242.4	0.032
264.10	0.088	242.5	0.032
264.13	0.087	242.4	0.032
264.17	0.087	242.4	0.032
264.20	0.087	242.4	0.032
264.23	0.087	242.4	0.032
264.27	0.087	242.4	0.032
264.30	0.086	242.4	0.0311
264.33	0.086	242.4	0.0311
264.37	0.085	242.4	0.0311
264.42	0.085	242.4	0.0311
264.45	0.084	242.4	0.0302

Prova triassiale ciclica SNME01-C3			
pressione di confinamento (kPa)		380	
deviatore ciclico (kPa)		80	
frequenza (hz)		0.00071429	
tempo	cella di carico	u	LVDT
(min)	kN	(kPa)	δ (mm)
264.47	0.084	242.4	0.0302
264.50	0.082	242.4	0.0311
264.53	0.082	242.3	0.0302
264.57	0.083	242.4	0.0302
264.60	0.083	242.3	0.0302
264.63	0.082	242.3	0.0293
264.67	0.082	242.3	0.0293
264.70	0.081	242.3	0.0293
264.73	0.08	242.3	0.0293
264.77	0.08	242.3	0.0293
264.80	0.08	242.3	0.0284
264.83	0.079	242.3	0.0284
264.87	0.078	242.2	0.0284
264.90	0.078	242.2	0.0284
264.93	0.078	242.2	0.0284
264.97	0.077	242.2	0.0275
265.00	0.077	242.2	0.0275
265.03	0.076	242.2	0.0275
265.07	0.075	242.1	0.0266
265.10	0.076	242.1	0.0266
265.13	0.075	242.1	0.0266
265.17	0.073	242.1	0.0266
265.20	0.073	242.1	0.0257
265.23	0.073	242.1	0.0257
265.27	0.073	242	0.0249
265.30	0.072	242	0.0249
265.33	0.071	242	0.0249
265.37	0.071	242	0.024
265.40	0.071	241.9	0.024
265.43	0.072	241.9	0.024
265.47	0.072	242	0.0231
265.50	0.067	241.8	0.0222
265.53	0.066	241.8	0.0222
265.57	0.067	241.8	0.0222
265.60	0.067	241.8	0.0213
265.63	0.066	241.7	0.0213
265.67	0.065	241.7	0.0213
265.70	0.065	241.7	0.0204
265.73	0.064	241.7	0.0204
265.77	0.064	241.7	0.0195
265.80	0.063	241.6	0.0195
265.83	0.062	241.6	0.0186
265.88	0.062	241.5	0.0186
265.90	0.06	241.5	0.0178
265.93	0.061	241.5	0.0178
265.97	0.061	241.5	0.0178
266.00	0.059	241.5	0.0178
266.03	0.059	241.4	0.0169
266.07	0.058	241.3	0.016
266.10	0.057	241.3	0.0151
266.13	0.057	241.3	0.0151
266.17	0.056	241.2	0.0142
266.20	0.055	241.2	0.0142
266.23	0.054	241.2	0.0133
266.27	0.054	241.1	0.0124
266.30	0.054	241.1	0.0115
266.33	0.052	241	0.0107
266.37	0.051	241	0.0107

Prova triassiale ciclica SNME01-C3			
pressione di confinamento (kPa)		380	
deviatore ciclico (kPa)		80	
frequenza (hz)		0.00071429	
tempo	cella di carico	u	LVDT
(min)	kN	(kPa)	δ (mm)
266.40	0.051	240.9	0.0098
266.43	0.051	240.9	0.0098
266.47	0.049	240.9	0.0089
266.50	0.049	240.8	0.0089
266.53	0.049	240.8	0.008
266.57	0.048	240.8	0.0071
266.60	0.046	240.7	0.0062
266.63	0.047	240.7	0.0053
266.67	0.047	240.7	0.0053
266.70	0.045	240.7	0.0053
266.73	0.045	240.6	0.0036
266.77	0.042	240.4	0.0027
266.80	0.042	240.4	0.0018
266.83	0.042	240.4	0.0009
266.87	0.041	240.3	0.0009
266.90	0.041	240.3	0.0009
266.93	0.039	240.3	0
266.97	0.039	240.2	-0.0009
267.00	0.038	240.1	-0.0018
267.03	0.038	240.1	-0.0027
267.07	0.037	240	-0.0036
267.10	0.036	240	-0.0044
267.13	0.034	239.9	-0.0044
267.17	0.034	239.9	-0.0062
267.20	0.034	239.9	-0.0062
267.23	0.033	239.8	-0.0071
267.27	0.032	239.7	-0.0089
267.32	0.031	239.7	-0.0098
267.35	0.031	239.6	-0.0107
267.37	0.03	239.6	-0.0107
267.40	0.027	239.5	-0.0124
267.43	0.029	239.5	-0.0133
267.47	0.028	239.4	-0.0133
267.50	0.026	239.4	-0.0142
267.53	0.026	239.3	-0.0151
267.57	0.026	239.3	-0.016
267.60	0.024	239.2	-0.0178
267.63	0.023	239.1	-0.0186
267.67	0.023	239	-0.0195
267.70	0.021	238.9	-0.0195
267.73	0.02	238.9	-0.0213
267.77	0.02	238.9	-0.0222
267.80	0.02	238.8	-0.0231
267.83	0.018	238.7	-0.0249
267.87	0.017	238.7	-0.0257
267.90	0.017	238.6	-0.0266
267.93	0.016	238.5	-0.0266
267.97	0.015	238.5	-0.0275
268.00	0.015	238.4	-0.0293
268.03	0.014	238.3	-0.0302
268.07	0.013	238.2	-0.032
268.10	0.012	238.2	-0.0328
268.13	0.011	238.1	-0.0337
268.17	0.01	238	-0.0337
268.20	0.009	238	-0.0355
268.23	0.009	237.9	-0.0364
268.27	0.007	237.9	-0.0382
268.30	0.008	237.8	-0.0391

Prova triassiale ciclica SNME01-C3			
pressione di confinamento (kPa)		380	
deviatore ciclico (kPa)		80	
frequenza (hz)		0.00071429	
tempo	cella di carico	u	LVDT
(min)	kN	(kPa)	δ (mm)
268.33	0.006	237.7	-0.0399
268.37	0.006	237.7	-0.0408
268.40	0.004	237.5	-0.0408
268.43	0.003	237.5	-0.0426
268.47	0.003	237.5	-0.0435
268.50	0.003	237.4	-0.0453
268.53	0.001	237.3	-0.0462
268.57	0.001	237.2	-0.0479
268.60	0	237.1	-0.0488
268.63	-0.002	237	-0.0488
268.67	-0.002	237	-0.0506
268.70	-0.002	236.9	-0.0515
268.73	-0.003	236.9	-0.0533
268.78	-0.005	236.8	-0.0541
268.82	-0.005	236.7	-0.0559
268.83	-0.005	236.6	-0.0568
268.87	-0.007	236.5	-0.0586
268.90	-0.007	236.5	-0.0604
268.93	-0.008	236.4	-0.0621
268.97	-0.011	236.3	-0.0621
269.00	-0.01	236.3	-0.0648
269.03	-0.01	236.2	-0.0675
269.07	-0.011	236.1	-0.0701
269.10	-0.012	235.9	-0.0737
269.13	-0.013	235.8	-0.0772
269.17	-0.013	235.7	-0.0808
269.20	-0.015	235.6	-0.0808
269.23	-0.016	235.6	-0.0843
269.27	-0.016	235.5	-0.0879
269.30	-0.016	235.4	-0.0923
269.33	-0.017	235.3	-0.0968
269.37	-0.019	235.1	-0.1021
269.40	-0.018	235.1	-0.1074
269.43	-0.02	234.9	-0.1074
269.47	-0.021	234.9	-0.1145
269.50	-0.021	234.8	-0.1234
269.53	-0.022	234.6	-0.1349
269.57	-0.023	234.4	-0.1491
269.60	-0.023	234.3	-0.1651
269.63	-0.024	234.1	-0.1766
269.67	-0.026	233.8	-0.1766
269.70	-0.026	233.8	-0.1855
269.73	-0.026	233.7	-0.1908
269.77	-0.027	233.6	-0.1953
269.80	-0.029	233.4	-0.1997
269.83	-0.029	233.3	-0.2033
269.87	-0.03	233.2	-0.2059
269.90	-0.031	233	-0.2059
269.93	-0.032	233	-0.2095
269.97	-0.032	232.9	-0.213
270.00	-0.032	232.8	-0.2157
270.03	-0.033	232.6	-0.2192
270.07	-0.034	232.5	-0.221
270.10	-0.035	232.4	-0.2228
270.13	-0.036	232.3	-0.2228
270.17	-0.037	232.3	-0.2246
270.22	-0.037	232	-0.2317
270.25	-0.038	231.9	-0.2317

Prova triassiale ciclica SNME01-C3			
pressione di confinamento (kPa)		380	
deviatore ciclico (kPa)		80	
frequenza (hz)		0.00071429	
tempo	cella di carico	u	LVDT
(min)	kN	(kPa)	δ (mm)
270.27	-0.039	231.9	-0.2343
270.30	-0.039	231.8	-0.237
270.33	-0.039	231.7	-0.2388
270.37	-0.041	231.6	-0.2406
270.40	-0.041	231.5	-0.2423
270.43	-0.042	231.4	-0.245
270.47	-0.044	231.2	-0.245
270.50	-0.043	231.2	-0.2485
270.53	-0.043	231.1	-0.2494
270.57	-0.044	231	-0.2521
270.60	-0.046	230.9	-0.2548
270.63	-0.045	230.8	-0.2565
270.67	-0.047	230.6	-0.2583
270.70	-0.048	230.5	-0.2583
270.73	-0.049	230.5	-0.261
270.77	-0.049	230.4	-0.2627
270.80	-0.049	230.3	-0.2645
270.83	-0.05	230.2	-0.2663
270.87	-0.05	230.1	-0.2681
270.90	-0.051	230	-0.2698
270.93	-0.052	229.8	-0.2698
270.97	-0.053	229.8	-0.2716
271.00	-0.053	229.7	-0.2734
271.03	-0.053	229.6	-0.2743
271.07	-0.055	229.5	-0.2761
271.10	-0.055	229.4	-0.2778
271.13	-0.055	229.3	-0.2787
271.17	-0.057	229.2	-0.2787
271.20	-0.057	229.2	-0.2814
271.23	-0.057	229.1	-0.2823
271.27	-0.057	229	-0.2832
271.30	-0.058	228.9	-0.2858
271.33	-0.059	228.8	-0.2876
271.37	-0.059	228.7	-0.2885
271.40	-0.06	228.6	-0.2885
271.43	-0.061	228.6	-0.2903
271.47	-0.061	228.5	-0.2911
271.50	-0.061	228.4	-0.2929
271.53	-0.062	228.3	-0.2947
271.57	-0.062	228.2	-0.2956
271.60	-0.064	228.1	-0.2974
271.63	-0.064	228	-0.2974
271.68	-0.064	227.9	-0.2991
271.72	-0.064	227.9	-0.3
271.73	-0.065	227.7	-0.3
271.77	-0.066	227.7	-0.3009
271.80	-0.066	227.7	-0.3018
271.83	-0.066	227.6	-0.3036
271.87	-0.067	227.5	-0.3045
271.90	-0.068	227.4	-0.3053
271.93	-0.068	227.3	-0.3062
271.97	-0.069	227.2	-0.3062
272.00	-0.069	227.2	-0.308
272.03	-0.069	227.1	-0.308
272.07	-0.07	227	-0.3098
272.10	-0.07	227	-0.3107
272.13	-0.07	226.9	-0.3116
272.17	-0.071	226.8	-0.3124

Prova triassiale ciclica SNME01-C3			
pressione di confinamento (kPa)		380	
deviatore ciclico (kPa)		80	
frequenza (hz)		0.00071429	
tempo	cella di carico	u	LVDT
(min)	kN	(kPa)	δ (mm)
272.20	-0.072	226.7	-0.3124
272.23	-0.072	226.7	-0.3133
272.27	-0.072	226.7	-0.3133
272.30	-0.073	226.6	-0.3151
272.33	-0.073	226.5	-0.316
272.37	-0.073	226.4	-0.316
272.40	-0.074	226.4	-0.3169
272.43	-0.074	226.3	-0.3169
272.47	-0.075	226.3	-0.3178
272.50	-0.075	226.2	-0.3187
272.53	-0.075	226.1	-0.3196
272.57	-0.076	226	-0.3204
272.60	-0.076	226	-0.3204
272.63	-0.077	225.9	-0.3213
272.67	-0.077	225.9	-0.3213
272.70	-0.077	225.9	-0.3222
272.73	-0.077	225.8	-0.3231
272.77	-0.078	225.8	-0.3231
272.80	-0.078	225.7	-0.324
272.83	-0.078	225.6	-0.3249
272.87	-0.079	225.6	-0.3249
272.90	-0.079	225.5	-0.3249
272.93	-0.079	225.5	-0.3258
272.97	-0.079	225.5	-0.3258
273.00	-0.079	225.4	-0.3267
273.03	-0.08	225.3	-0.3275
273.07	-0.08	225.3	-0.3275
273.12	-0.08	225.3	-0.3275
273.15	-0.081	225.2	-0.3284
273.17	-0.081	225.2	-0.3284
273.20	-0.081	225.1	-0.3293
273.23	-0.082	225	-0.3293
273.27	-0.082	225	-0.3302
273.30	-0.082	225	-0.3302
273.33	-0.082	225	-0.3302
273.37	-0.082	224.9	-0.3311
273.40	-0.082	224.9	-0.3311
273.43	-0.083	224.8	-0.332
273.47	-0.083	224.8	-0.332
273.50	-0.083	224.8	-0.332
273.53	-0.083	224.7	-0.3329
273.57	-0.083	224.6	-0.3329
273.60	-0.083	224.6	-0.3329
273.63	-0.083	224.6	-0.3338
273.67	-0.083	224.5	-0.3338
273.70	-0.083	224.5	-0.3338
273.73	-0.083	224.5	-0.3338
273.77	-0.083	224.5	-0.3346
273.80	-0.084	224.4	-0.3346
273.83	-0.084	224.4	-0.3355
273.87	-0.084	224.3	-0.3355
273.90	-0.084	224.3	-0.3355
273.93	-0.084	224.3	-0.3355
273.97	-0.084	224.3	-0.3355
274.00	-0.084	224.3	-0.3364
274.03	-0.084	224.2	-0.3364
274.07	-0.084	224.2	-0.3364
274.10	-0.084	224.2	-0.3364

Prova triassiale ciclica SNME01-C3			
pressione di confinamento (kPa)		380	
deviatore ciclico (kPa)		80	
frequenza (hz)		0.00071429	
tempo	cella di carico	u	LVDT
(min)	kN	(kPa)	δ (mm)
274.13	-0.084	224.1	-0.3373
274.17	-0.084	224.1	-0.3373
274.20	-0.084	224.1	-0.3373
274.23	-0.084	224.1	-0.3373
274.27	-0.084	224	-0.3373
274.30	-0.084	224	-0.3373
274.33	-0.084	224	-0.3373
274.37	-0.084	224	-0.3382
274.40	-0.084	224	-0.3382
274.43	-0.084	224	-0.3382
274.47	-0.084	223.9	-0.3382
274.50	-0.084	223.9	-0.3382
274.53	-0.084	223.9	-0.3382
274.58	-0.083	223.9	-0.3382
274.62	-0.084	223.9	-0.3382
274.63	-0.083	223.9	-0.3382
274.67	-0.084	223.8	-0.3382
274.70	-0.084	223.8	-0.3382
274.73	-0.083	223.8	-0.3382
274.77	-0.083	223.8	-0.3382
274.80	-0.083	223.8	-0.3382
274.83	-0.083	223.8	-0.3382
274.87	-0.083	223.8	-0.3382
274.90	-0.083	223.8	-0.3382
274.93	-0.082	223.8	-0.3382
274.97	-0.082	223.8	-0.3382
275.00	-0.082	223.8	-0.3382
275.03	-0.082	223.8	-0.3382
275.07	-0.082	223.8	-0.3382
275.10	-0.082	223.8	-0.3382
275.13	-0.082	223.8	-0.3382
275.17	-0.081	223.8	-0.3382
275.20	-0.081	223.8	-0.3382
275.23	-0.081	223.8	-0.3382
275.27	-0.081	223.8	-0.3382
275.30	-0.081	223.8	-0.3382
275.33	-0.08	223.8	-0.3382
275.37	-0.08	223.8	-0.3382
275.40	-0.079	223.8	-0.3382
275.43	-0.079	223.8	-0.3382
275.47	-0.079	223.8	-0.3382
275.50	-0.079	223.8	-0.3382
275.53	-0.078	223.8	-0.3373
275.57	-0.078	223.8	-0.3373
275.60	-0.078	223.8	-0.3373
275.63	-0.078	223.8	-0.3373
275.67	-0.077	223.8	-0.3373
275.70	-0.077	223.8	-0.3373
275.73	-0.077	223.9	-0.3364
275.77	-0.077	223.9	-0.3364
275.80	-0.076	223.9	-0.3364
275.83	-0.076	223.9	-0.3364
275.87	-0.075	223.9	-0.3364
275.90	-0.075	223.9	-0.3364
275.93	-0.075	223.9	-0.3355
275.97	-0.075	223.9	-0.3355
276.00	-0.074	224	-0.3355
276.05	-0.073	224	-0.3355

Prova triassiale ciclica SNME01-C3			
ensione di confinamento (kPa)		380	
deviatore ciclico (kPa)		80	
frequenza (hz)		0.00071429	
tempo	cella di carico	u	LVDT
(min)	kN	(kPa)	δ (mm)
276.08	-0.073	224	-0.3355
276.10	-0.073	224	-0.3346
276.13	-0.073	224.1	-0.3346
276.17	-0.071	224.1	-0.3338
276.20	-0.071	224.1	-0.3338
276.23	-0.071	224.1	-0.3338
276.27	-0.07	224.2	-0.3338
276.30	-0.07	224.2	-0.3338
276.33	-0.07	224.1	-0.3338
276.37	-0.07	224.2	-0.3329
276.40	-0.069	224.2	-0.3329
276.43	-0.068	224.2	-0.332
276.47	-0.068	224.3	-0.332
276.50	-0.068	224.3	-0.332
276.53	-0.068	224.3	-0.332
276.57	-0.067	224.3	-0.3311
276.60	-0.066	224.4	-0.3311
276.63	-0.066	224.4	-0.3302
276.67	-0.065	224.5	-0.3302
276.70	-0.065	224.5	-0.3302
276.73	-0.063	224.6	-0.3302
276.77	-0.063	224.6	-0.3293
276.80	-0.064	224.6	-0.3293
276.83	-0.063	224.6	-0.3284
276.87	-0.062	224.7	-0.3275
276.90	-0.062	224.7	-0.3275
276.93	-0.061	224.8	-0.3275
276.97	-0.06	224.9	-0.3267
277.00	-0.06	224.9	-0.3267
277.03	-0.059	224.9	-0.3258
277.07	-0.059	224.9	-0.3258
277.10	-0.058	225	-0.3249
277.13	-0.057	225	-0.324
277.17	-0.056	225.1	-0.324
277.20	-0.056	225.1	-0.324
277.23	-0.056	225.1	-0.3231
277.27	-0.056	225.2	-0.3231
277.30	-0.055	225.3	-0.3222
277.33	-0.054	225.3	-0.3213
277.37	-0.053	225.4	-0.3204
277.40	-0.052	225.4	-0.3204
277.43	-0.052	225.5	-0.3196
277.48	-0.051	225.5	-0.3187
277.52	-0.051	225.6	-0.3187
277.53	-0.05	225.6	-0.3178
277.57	-0.05	225.6	-0.3178
277.60	-0.049	225.7	-0.316
277.63	-0.048	225.7	-0.316
277.67	-0.048	225.8	-0.3151
277.70	-0.047	225.9	-0.3142
277.73	-0.046	225.9	-0.3142
277.77	-0.045	226	-0.3133
277.80	-0.045	226	-0.3116
277.83	-0.045	226.1	-0.3116
277.87	-0.044	226.2	-0.3098
277.90	-0.043	226.2	-0.3089
277.93	-0.043	226.3	-0.308
277.97	-0.042	226.4	-0.308

Prova triassiale ciclica SNME01-C3			
pressione di confinamento (kPa)		380	
deviatore ciclico (kPa)		80	
frequenza (hz)		0.00071429	
tempo	cella di carico	u	LVDT
(min)	kN	(kPa)	δ (mm)
278.00	-0.041	226.4	-0.3071
278.03	-0.041	226.4	-0.3062
278.07	-0.04	226.5	-0.3053
278.10	-0.038	226.6	-0.3036
278.13	-0.038	226.7	-0.3036
278.17	-0.038	226.7	-0.3027
278.20	-0.037	226.8	-0.3027
278.23	-0.036	226.9	-0.3009
278.27	-0.036	226.9	-0.2991
278.30	-0.035	227	-0.2982
278.33	-0.034	227.1	-0.2965
278.37	-0.033	227.2	-0.2956
278.40	-0.032	227.3	-0.2938
278.43	-0.031	227.3	-0.2938
278.47	-0.031	227.4	-0.2929
278.50	-0.031	227.4	-0.2911
278.53	-0.03	227.5	-0.2903
278.57	-0.029	227.6	-0.2885
278.60	-0.028	227.7	-0.2867
278.63	-0.028	227.8	-0.284
278.67	-0.027	227.9	-0.284
278.70	-0.026	228	-0.2823
278.73	-0.026	228	-0.2805
278.77	-0.025	228.1	-0.2787
278.80	-0.024	228.2	-0.2769
278.83	-0.023	228.3	-0.2752
278.87	-0.022	228.3	-0.2734
278.90	-0.021	228.5	-0.2734
278.95	-0.02	228.6	-0.2698
278.98	-0.02	228.6	-0.2681
279.00	-0.019	228.8	-0.2681
279.03	-0.018	228.8	-0.2654
279.07	-0.018	228.8	-0.2636
279.10	-0.016	229	-0.2619
279.13	-0.016	229.1	-0.2601
279.17	-0.015	229.2	-0.2574
279.20	-0.015	229.3	-0.2556
279.23	-0.014	229.4	-0.2556
279.27	-0.012	229.5	-0.253
279.30	-0.012	229.5	-0.2494
279.33	-0.012	229.6	-0.2477
279.37	-0.01	229.7	-0.2441
279.40	-0.009	229.8	-0.2414
279.43	-0.009	230	-0.2388
279.47	-0.008	230.1	-0.2388
279.50	-0.007	230.2	-0.2361
279.53	-0.007	230.2	-0.2326
279.57	-0.006	230.3	-0.229
279.60	-0.005	230.5	-0.2255
279.63	-0.004	230.6	-0.2219
279.67	-0.003	230.7	-0.2184
279.70	-0.002	230.8	-0.2184
279.73	-0.001	230.9	-0.2148
279.77	-0.001	230.9	-0.2113
279.80	0	231	-0.2068
279.83	0	231.2	-0.2033
279.87	0.002	231.3	-0.1988
279.90	0.002	231.4	-0.1944

Prova triassiale ciclica SNME01-C3			
pressione di confinamento (kPa)		380	
deviatore ciclico (kPa)		80	
frequenza (hz)		0.00071429	
tempo	cella di carico	u	LVDT
(min)	kN	(kPa)	δ (mm)
279.93	0.004	231.6	-0.1944
279.97	0.005	231.7	-0.19
280.00	0.005	231.7	-0.1864
280.03	0.005	231.8	-0.1837
280.07	0.006	231.9	-0.1802
280.10	0.007	232	-0.1775
280.13	0.008	232.1	-0.1713
280.17	0.009	232.3	-0.1713
280.20	0.01	232.5	-0.166
280.23	0.01	232.5	-0.1598
280.27	0.011	232.6	-0.1553
280.30	0.012	232.7	-0.15
280.33	0.013	232.8	-0.1447
280.38	0.013	232.9	-0.1402
280.42	0.014	233.1	-0.1358
280.43	0.015	233.2	-0.1314
280.47	0.016	233.3	-0.1269
280.50	0.017	233.4	-0.1269
280.53	0.019	233.6	-0.1225
280.57	0.019	233.6	-0.1181
280.60	0.019	233.7	-0.1136
280.63	0.02	233.8	-0.1092
280.67	0.022	233.9	-0.1047
280.70	0.021	234	-0.1003
280.73	0.023	234.1	-0.1003
280.77	0.024	234.2	-0.0959
280.80	0.024	234.2	-0.0923
280.83	0.025	234.3	-0.0879
280.87	0.026	234.5	-0.0843
280.90	0.027	234.6	-0.0808
280.93	0.027	234.6	-0.0781
280.97	0.028	234.7	-0.0781
281.00	0.029	234.8	-0.0754
281.03	0.029	234.8	-0.0728
281.07	0.03	234.9	-0.071
281.10	0.031	235	-0.0683
281.13	0.033	235	-0.0666
281.17	0.032	235.1	-0.0657
281.20	0.034	235.2	-0.0657
281.23	0.035	235.3	-0.0639
281.27	0.035	235.3	-0.0621
281.30	0.035	235.3	-0.0612
281.33	0.036	235.4	-0.0595
281.37	0.038	235.5	-0.0568
281.40	0.038	235.6	-0.0559
281.43	0.039	235.6	-0.0559
281.47	0.04	235.7	-0.0541
281.50	0.04	235.7	-0.0524
281.53	0.041	235.8	-0.0515
281.57	0.042	235.9	-0.0506
281.60	0.043	235.9	-0.0488
281.63	0.044	236	-0.047
281.67	0.044	236.1	-0.047
281.70	0.046	236.2	-0.0462
281.73	0.046	236.2	-0.0453
281.77	0.046	236.2	-0.0435
281.80	0.047	236.3	-0.0426
281.85	0.048	236.4	-0.0417

Prova triassiale ciclica SNME01-C3			
pressione di confinamento (kPa)		380	
deviatore ciclico (kPa)		80	
frequenza (hz)		0.00071429	
tempo	cella di carico	u	LVDT
(min)	kN	(kPa)	δ (mm)
281.88	0.048	236.5	-0.0408
281.90	0.049	236.5	-0.0391
281.93	0.05	236.6	-0.0382
281.97	0.05	236.7	-0.0373
282.00	0.052	236.8	-0.0373
282.03	0.053	236.9	-0.0355
282.07	0.053	236.9	-0.0346
282.10	0.053	236.9	-0.0337
282.13	0.054	237	-0.032
282.17	0.055	237.1	-0.0311
282.20	0.055	237.2	-0.0302
282.23	0.056	237.2	-0.0302
282.27	0.057	237.4	-0.0293
282.30	0.057	237.4	-0.0275
282.33	0.058	237.4	-0.0266
282.37	0.059	237.5	-0.0257
282.40	0.059	237.6	-0.0249
282.43	0.06	237.7	-0.024
282.47	0.061	237.8	-0.024
282.50	0.062	237.8	-0.0222
282.53	0.062	237.8	-0.0213
282.57	0.062	237.9	-0.0204
282.60	0.063	238	-0.0186
282.63	0.064	238.1	-0.0178
282.67	0.064	238.1	-0.0169
282.70	0.066	238.2	-0.0169
282.73	0.066	238.3	-0.016
282.77	0.066	238.3	-0.0151
282.80	0.067	238.4	-0.0142
282.83	0.067	238.4	-0.0133
282.87	0.068	238.5	-0.0124
282.90	0.069	238.6	-0.0115
282.93	0.07	238.7	-0.0115
282.97	0.07	238.8	-0.0107
283.00	0.07	238.8	-0.0098
283.03	0.071	238.8	-0.008
283.07	0.071	238.9	-0.0071
283.10	0.072	239	-0.0062
283.13	0.073	239	-0.0053
283.17	0.074	239.1	-0.0053
283.20	0.074	239.2	-0.0044
283.23	0.074	239.2	-0.0044
283.27	0.074	239.3	-0.0036
283.32	0.075	239.4	-0.0018
283.33	0.075	239.4	-0.0018
283.37	0.076	239.5	0
283.40	0.077	239.5	0
283.43	0.078	239.6	0.0009
283.47	0.078	239.7	0.0018
283.50	0.078	239.7	0.0018
283.53	0.079	239.8	0.0027
283.57	0.079	239.8	0.0036
283.60	0.079	239.9	0.0036
283.63	0.08	239.9	0.0044
283.67	0.081	240	0.0053
283.70	0.081	240.1	0.0062
283.73	0.081	240.1	0.0062
283.77	0.083	240.2	0.0071

Prova triassiale ciclica SNME01-C3			
pressione di confinamento (kPa)		380	
deviatore ciclico (kPa)		80	
frequenza (hz)		0.00071429	
tempo	cella di carico	u	LVDT
(min)	kN	(kPa)	δ (mm)
283.80	0.083	240.2	0.008
283.83	0.082	240.3	0.0089
283.87	0.083	240.3	0.0089
283.90	0.084	240.4	0.0098
283.93	0.084	240.4	0.0107
283.97	0.084	240.5	0.0107
284.00	0.085	240.6	0.0115
284.03	0.085	240.6	0.0115
284.07	0.085	240.6	0.0124
284.10	0.086	240.7	0.0133
284.13	0.086	240.7	0.0133
284.17	0.086	240.8	0.0142
284.20	0.087	240.9	0.0142
284.23	0.088	240.9	0.0151
284.27	0.088	240.9	0.016
284.30	0.088	241	0.016
284.33	0.088	241	0.0169
284.37	0.089	241.1	0.0169
284.40	0.089	241.1	0.0178
284.43	0.089	241.2	0.0178
284.47	0.09	241.3	0.0186
284.50	0.09	241.3	0.0186
284.53	0.09	241.3	0.0195
284.57	0.09	241.4	0.0195
284.60	0.091	241.4	0.0204
284.63	0.091	241.5	0.0204
284.67	0.091	241.5	0.0204
284.70	0.092	241.6	0.0213
284.75	0.092	241.6	0.0222
284.78	0.092	241.7	0.0222
284.80	0.093	241.7	0.0222
284.83	0.093	241.7	0.0231
284.87	0.093	241.8	0.0231
284.90	0.093	241.8	0.024
284.93	0.093	241.9	0.024
284.97	0.094	242	0.0249
285.00	0.094	242	0.0249
285.03	0.092	241.9	0.0249
285.07	0.092	241.9	0.0249
285.10	0.092	242	0.0249
285.13	0.095	242.1	0.0266
285.17	0.095	242.2	0.0266
285.20	0.094	242.2	0.0266
285.23	0.097	242.3	0.0266
285.27	0.096	242.3	0.0275
285.30	0.096	242.3	0.0275
285.33	0.095	242.3	0.0275
285.37	0.095	242.3	0.0275
285.40	0.095	242.4	0.0284
285.43	0.096	242.4	0.0284
285.47	0.096	242.5	0.0284
285.50	0.095	242.5	0.0284
285.53	0.095	242.5	0.0284
285.57	0.095	242.5	0.0293
285.60	0.096	242.6	0.0293
285.63	0.096	242.6	0.0293
285.67	0.096	242.6	0.0293
285.70	0.096	242.7	0.0293

Prova triassiale ciclica SNME01-C3			
pressione di confinamento (kPa)		380	
deviatore ciclico (kPa)		80	
frequenza (hz)		0.00071429	
tempo	cella di carico	u	LVDT
(min)	kN	(kPa)	δ (mm)
285.73	0.096	242.7	0.0302
285.77	0.096	242.7	0.0302
285.80	0.096	242.7	0.0302
285.83	0.096	242.7	0.0293
285.87	0.094	242.7	0.0302
285.90	0.095	242.8	0.0302
285.93	0.098	242.9	0.0302
285.97	0.097	242.9	0.0311
286.00	0.097	242.9	0.0311
286.03	0.094	242.8	0.0302
286.07	0.094	242.8	0.0311
286.10	0.096	242.9	0.0311
286.13	0.095	242.9	0.0311
286.17	0.096	242.9	0.0311
286.22	0.097	243	0.0311
286.25	0.094	242.9	0.0311
286.27	0.094	242.9	0.0311
286.30	0.095	243	0.0311
286.33	0.095	243	0.0311
286.37	0.095	243	0.032
286.40	0.097	243.1	0.032
286.43	0.093	243	0.0311
286.47	0.094	243.1	0.032
286.50	0.095	243.1	0.032
286.53	0.095	243.1	0.032
286.57	0.095	243.1	0.032
286.60	0.094	243.1	0.032
286.63	0.096	243.2	0.032
286.67	0.094	243.2	0.032
286.70	0.094	243.2	0.032
286.73	0.093	243.2	0.032
286.77	0.091	243.1	0.032
286.80	0.091	243.1	0.0311
286.83	0.092	243.2	0.032
286.87	0.093	243.2	0.032
286.90	0.093	243.2	0.032
286.93	0.093	243.2	0.032
286.97	0.093	243.3	0.032
287.00	0.093	243.3	0.032
287.03	0.093	243.3	0.032
287.07	0.092	243.3	0.0311
287.10	0.088	243.2	0.0302
287.13	0.089	243.2	0.0311
287.17	0.092	243.3	0.032
287.20	0.092	243.3	0.032
287.23	0.09	243.3	0.032
287.27	0.09	243.3	0.0311
287.30	0.089	243.3	0.0311
287.33	0.088	243.2	0.0302
287.37	0.087	243.2	0.0302
287.40	0.088	243.3	0.0311
287.43	0.09	243.3	0.0311
287.47	0.088	243.3	0.0311
287.50	0.088	243.3	0.0302
287.53	0.088	243.3	0.0293
287.57	0.084	243.2	0.0293
287.60	0.085	243.2	0.0293
287.65	0.087	243.3	0.0302

Prova triassiale ciclica SNME01-C3			
pressione di confinamento (kPa)		380	
deviatore ciclico (kPa)		80	
frequenza (hz)		0.00071429	
tempo	cella di carico	u	LVDT
(min)	kN	(kPa)	δ (mm)
287.68	0.087	243.3	0.0302
287.70	0.085	243.2	0.0293
287.73	0.083	243.2	0.0293
287.77	0.085	243.2	0.0293
287.80	0.084	243.2	0.0293
287.83	0.084	243.2	0.0293
287.87	0.081	243.1	0.0284
287.90	0.083	243.2	0.0284
287.93	0.084	243.2	0.0284
287.97	0.082	243.2	0.0284
288.00	0.078	243	0.0266
288.03	0.081	243.1	0.0266
288.07	0.081	243.1	0.0284
288.10	0.079	243.1	0.0266
288.13	0.079	243.1	0.0266
288.17	0.079	243.1	0.0266
288.20	0.079	243.1	0.0266
288.23	0.081	243.1	0.0275
288.27	0.074	243	0.0275
288.30	0.074	243	0.0257
288.33	0.077	243	0.0257
288.37	0.079	243.1	0.0266
288.40	0.074	242.9	0.0249
288.43	0.075	242.9	0.0249
288.47	0.076	243	0.0249
288.50	0.073	242.9	0.0249
288.53	0.073	242.9	0.024
288.57	0.075	242.9	0.0249
288.60	0.074	242.9	0.024
288.63	0.072	242.8	0.0231
288.67	0.071	242.8	0.0231
288.70	0.071	242.8	0.0231
288.73	0.071	242.8	0.0231
288.77	0.071	242.8	0.0222
288.80	0.068	242.7	0.0213
288.83	0.068	242.7	0.0213
288.87	0.069	242.7	0.0213
288.90	0.067	242.7	0.0204
288.93	0.066	242.6	0.0195
288.97	0.065	242.6	0.0195
289.00	0.065	242.6	0.0195
289.03	0.065	242.6	0.0195
289.07	0.065	242.5	0.0186
289.12	0.064	242.5	0.0178
289.15	0.064	242.5	0.0178
289.17	0.063	242.4	0.0169
289.20	0.062	242.4	0.0169
289.23	0.061	242.4	0.016
289.27	0.06	242.3	0.016
289.30	0.06	242.3	0.016
289.33	0.059	242.3	0.0151
289.37	0.059	242.3	0.0142
289.40	0.059	242.2	0.0142
289.43	0.058	242.2	0.0133
289.47	0.057	242.1	0.0133
289.50	0.056	242.1	0.0124
289.53	0.055	242	0.0124
289.57	0.054	242	0.0115

Prova triassiale ciclica SNME01-C3			
ensione di confinamento (kPa)		380	
deviatore ciclico (kPa)		80	
frequenza (hz)		0.00071429	
tempo	cella di carico	u	LVDT
(min)	kN	(kPa)	δ (mm)
289.60	0.054	242	0.0107
289.63	0.054	242	0.0107
289.67	0.052	241.9	0.0098
289.70	0.052	241.9	0.0089
289.73	0.051	241.8	0.008
289.77	0.05	241.8	0.008
289.80	0.05	241.8	0.0071
289.83	0.05	241.7	0.0062
289.87	0.048	241.6	0.0053
289.90	0.048	241.6	0.0053
289.93	0.047	241.6	0.0044
289.97	0.046	241.4	0.0036
290.00	0.045	241.4	0.0036
290.03	0.044	241.4	0.0027
290.07	0.044	241.4	0.0018
290.10	0.044	241.3	0.0009
290.13	0.042	241.3	0
290.17	0.042	241.2	-0.0009
290.20	0.041	241.2	-0.0009
290.23	0.041	241.1	-0.0009
290.27	0.039	241.1	-0.0018
290.30	0.039	241	-0.0027
290.33	0.039	241	-0.0036
290.37	0.037	240.9	-0.0044
290.40	0.037	240.9	-0.0053
290.43	0.036	240.8	-0.0071
290.47	0.034	240.7	-0.0071
290.50	0.035	240.7	-0.008
290.55	0.033	240.6	-0.0098
290.58	0.032	240.5	-0.0098
290.60	0.032	240.5	-0.0107
290.63	0.032	240.5	-0.0115
290.67	0.031	240.5	-0.0124
290.70	0.029	240.4	-0.0133
290.73	0.029	240.3	-0.0142
290.77	0.028	240.2	-0.016
290.80	0.026	240.2	-0.016
290.83	0.027	240.2	-0.0169
290.87	0.027	240.1	-0.0178
290.90	0.024	240	-0.0186
290.93	0.025	240	-0.0195
290.97	0.023	239.9	-0.0213
291.00	0.023	239.9	-0.0222
291.03	0.021	239.8	-0.0222
291.07	0.021	239.8	-0.0231
291.10	0.021	239.7	-0.024
291.13	0.02	239.6	-0.0257
291.17	0.018	239.5	-0.0266
291.20	0.018	239.5	-0.0284
291.23	0.016	239.4	-0.0293
291.27	0.016	239.3	-0.0293
291.30	0.015	239.3	-0.0302
291.33	0.015	239.2	-0.032
291.37	0.014	239.2	-0.0328
291.40	0.013	239.1	-0.0337
291.43	0.012	239	-0.0355
291.47	0.011	238.9	-0.0364
291.50	0.01	238.8	-0.0364

Prova triassiale ciclica SNME01-C3			
pressione di confinamento (kPa)		380	
deviatore ciclico (kPa)		80	
frequenza (hz)		0.00071429	
tempo	cella di carico	u	LVDT
(min)	kN	(kPa)	δ (mm)
291.53	0.009	238.8	-0.0373
291.57	0.009	238.8	-0.0391
291.60	0.008	238.7	-0.0399
291.63	0.007	238.6	-0.0417
291.67	0.006	238.5	-0.0426
291.70	0.006	238.4	-0.0435
291.73	0.005	238.3	-0.0435
291.77	0.003	238.3	-0.0453
291.80	0.003	238.3	-0.0462
291.83	0.002	238.2	-0.0479
291.87	0.002	238.1	-0.0488
291.90	0.001	238	-0.0506
291.93	0	237.9	-0.0515
291.97	-0.002	237.8	-0.0515
292.02	-0.002	237.8	-0.0541
292.05	-0.003	237.7	-0.055
292.07	-0.004	237.6	-0.055
292.10	-0.005	237.6	-0.0559
292.13	-0.005	237.6	-0.0586
292.17	-0.005	237.5	-0.0595
292.20	-0.007	237.4	-0.0612
292.23	-0.008	237.3	-0.0621
292.27	-0.008	237.2	-0.0639
292.30	-0.009	237.1	-0.0639
292.33	-0.01	237.1	-0.0648
292.37	-0.01	237	-0.0666
292.40	-0.011	236.9	-0.071
292.43	-0.012	236.8	-0.0746
292.47	-0.012	236.6	-0.0781
292.50	-0.014	236.5	-0.0834
292.53	-0.016	236.4	-0.0834
292.57	-0.015	236.4	-0.0879
292.60	-0.015	236.3	-0.0914
292.63	-0.016	236.2	-0.0959
292.67	-0.018	236	-0.1021
292.70	-0.018	235.9	-0.1083
292.73	-0.019	235.8	-0.1154
292.77	-0.02	235.6	-0.1154
292.80	-0.021	235.6	-0.1234
292.83	-0.021	235.5	-0.1331
292.87	-0.021	235.4	-0.1465
292.90	-0.023	235.1	-0.1624
292.93	-0.024	234.9	-0.174
292.97	-0.024	234.8	-0.1837
293.00	-0.026	234.6	-0.1837
293.03	-0.026	234.6	-0.19
293.07	-0.026	234.5	-0.1944
293.10	-0.027	234.3	-0.1988
293.13	-0.029	234.2	-0.2042
293.17	-0.029	234.1	-0.2068
293.20	-0.03	233.9	-0.2104
293.23	-0.032	233.8	-0.2104
293.27	-0.032	233.8	-0.213
293.30	-0.032	233.7	-0.2157
293.33	-0.032	233.6	-0.2192
293.37	-0.033	233.5	-0.221
293.40	-0.034	233.3	-0.2237
293.43	-0.035	233.2	-0.2246

Prova triassiale ciclica SNME01-C3			
pressione di confinamento (kPa)		380	
deviatore ciclico (kPa)		80	
frequenza (hz)		0.00071429	
tempo	cella di carico	u	LVDT
(min)	kN	(kPa)	δ (mm)
293.48	-0.036	233.1	-0.2263
293.50	-0.036	232.9	-0.2317
293.53	-0.037	232.8	-0.2343
293.57	-0.038	232.7	-0.2343
293.60	-0.039	232.7	-0.237
293.63	-0.039	232.6	-0.2388
293.67	-0.039	232.5	-0.2414
293.70	-0.041	232.3	-0.2441
293.73	-0.041	232.2	-0.2459
293.77	-0.042	232.1	-0.2485
293.80	-0.043	232	-0.2485
293.83	-0.044	232	-0.2503
293.87	-0.044	231.9	-0.253
293.90	-0.044	231.7	-0.2548
293.93	-0.045	231.6	-0.2574
293.97	-0.046	231.5	-0.2592
294.00	-0.047	231.4	-0.261
294.03	-0.048	231.3	-0.261
294.07	-0.048	231.3	-0.2627
294.10	-0.048	231.2	-0.2645
294.13	-0.049	231.1	-0.2663
294.17	-0.051	230.9	-0.2681
294.20	-0.05	230.9	-0.2698
294.23	-0.051	230.8	-0.2716
294.27	-0.052	230.6	-0.2716
294.30	-0.053	230.6	-0.2734
294.33	-0.053	230.5	-0.2743
294.37	-0.053	230.4	-0.2769
294.40	-0.055	230.3	-0.2787
294.43	-0.055	230.2	-0.2805
294.47	-0.055	230.1	-0.2814
294.50	-0.057	230	-0.2814
294.53	-0.057	230	-0.2832
294.57	-0.057	229.9	-0.284
294.60	-0.057	229.8	-0.2867
294.63	-0.059	229.6	-0.2885
294.67	-0.059	229.5	-0.2903
294.70	-0.059	229.5	-0.2911
294.73	-0.061	229.3	-0.2911
294.77	-0.061	229.3	-0.2929
294.80	-0.061	229.3	-0.2938
294.83	-0.061	229.2	-0.2947
294.87	-0.062	229.1	-0.2965
294.92	-0.062	229	-0.2974
294.95	-0.062	228.9	-0.2982
294.97	-0.064	228.7	-0.3
295.00	-0.064	228.7	-0.3009
295.03	-0.065	228.6	-0.3027
295.07	-0.066	228.5	-0.3027
295.10	-0.066	228.5	-0.3036
295.13	-0.066	228.4	-0.3045
295.17	-0.066	228.3	-0.3053
295.20	-0.067	228.2	-0.3062
295.23	-0.068	228.1	-0.308
295.27	-0.068	228.1	-0.308
295.30	-0.068	228	-0.308
295.33	-0.069	228	-0.3089
295.37	-0.069	227.9	-0.3107

Prova triassiale ciclica SNME01-C3			
pressione di confinamento (kPa)		380	
deviatore ciclico (kPa)		80	
frequenza (hz)		0.00071429	
tempo	cella di carico	u	LVDT
(min)	kN	(kPa)	δ (mm)
295.40	-0.069	227.8	-0.3116
295.43	-0.07	227.7	-0.3124
295.47	-0.071	227.6	-0.3133
295.50	-0.071	227.6	-0.3142
295.53	-0.072	227.5	-0.3142
295.57	-0.072	227.5	-0.3151
295.60	-0.072	227.4	-0.316
295.63	-0.073	227.3	-0.3169
295.67	-0.073	227.2	-0.3178
295.70	-0.074	227.2	-0.3178
295.73	-0.074	227.1	-0.3187
295.77	-0.074	227	-0.3187
295.80	-0.074	227	-0.3196
295.83	-0.074	227	-0.3204
295.87	-0.076	226.9	-0.3213
295.90	-0.076	226.8	-0.3222
295.93	-0.076	226.7	-0.3231
295.97	-0.077	226.7	-0.324
296.00	-0.077	226.6	-0.324
296.03	-0.077	226.6	-0.324
296.07	-0.077	226.6	-0.3249
296.10	-0.078	226.4	-0.3258
296.13	-0.078	226.4	-0.3267
296.17	-0.079	226.3	-0.3267
296.20	-0.078	226.3	-0.3275
296.23	-0.079	226.2	-0.3275
296.27	-0.079	226.2	-0.3284
296.30	-0.079	226.2	-0.3284
296.33	-0.079	226.1	-0.3293
296.38	-0.08	226	-0.3293
296.42	-0.08	226	-0.3302
296.43	-0.08	226	-0.3302
296.47	-0.081	225.9	-0.3311
296.50	-0.081	225.8	-0.332
296.53	-0.081	225.8	-0.332
296.57	-0.082	225.7	-0.332
296.60	-0.081	225.7	-0.3329
296.63	-0.081	225.7	-0.3329
296.67	-0.082	225.6	-0.3338
296.70	-0.082	225.6	-0.3338
296.73	-0.082	225.5	-0.3346
296.77	-0.083	225.5	-0.3346
296.80	-0.083	225.5	-0.3346
296.83	-0.082	225.5	-0.3346
296.87	-0.082	225.4	-0.3355
296.90	-0.083	225.4	-0.3355
296.93	-0.083	225.3	-0.3364
296.97	-0.084	225.3	-0.3364
297.00	-0.083	225.3	-0.3364
297.03	-0.083	225.2	-0.3364
297.07	-0.083	225.2	-0.3364
297.10	-0.083	225.2	-0.3373
297.13	-0.083	225.2	-0.3373
297.17	-0.084	225.1	-0.3382
297.20	-0.084	225.1	-0.3382
297.23	-0.084	225	-0.3382
297.27	-0.084	225	-0.3382
297.30	-0.084	225	-0.3382

Prova triassiale ciclica SNME01-C3			
pressione di confinamento (kPa)		380	
deviatore ciclico (kPa)		80	
frequenza (hz)		0.00071429	
tempo	cella di carico	u	LVDT
(min)	kN	(kPa)	δ (mm)
297.33	-0.084	225	-0.3391
297.37	-0.084	225	-0.3391
297.40	-0.084	224.9	-0.3391
297.43	-0.084	224.9	-0.3391
297.47	-0.084	224.9	-0.3391
297.50	-0.084	224.8	-0.3391
297.53	-0.085	224.8	-0.34
297.57	-0.085	224.8	-0.34
297.60	-0.084	224.8	-0.34
297.63	-0.084	224.8	-0.34
297.67	-0.084	224.8	-0.34
297.70	-0.084	224.7	-0.34
297.73	-0.084	224.7	-0.34
297.77	-0.084	224.7	-0.34
297.82	-0.084	224.6	-0.3409
297.85	-0.084	224.6	-0.3409
297.87	-0.084	224.6	-0.3409
297.90	-0.084	224.6	-0.3409
297.93	-0.084	224.6	-0.3409
297.97	-0.084	224.6	-0.3409
298.00	-0.084	224.6	-0.3409
298.03	-0.083	224.5	-0.3409
298.07	-0.083	224.5	-0.3409
298.10	-0.083	224.5	-0.3409
298.13	-0.083	224.5	-0.3409
298.17	-0.083	224.5	-0.3409
298.20	-0.083	224.5	-0.3409
298.23	-0.083	224.5	-0.3409
298.27	-0.083	224.5	-0.3409
298.30	-0.082	224.5	-0.3409
298.33	-0.082	224.5	-0.3409
298.37	-0.082	224.5	-0.3409
298.40	-0.082	224.5	-0.3409
298.43	-0.082	224.5	-0.3409
298.47	-0.082	224.5	-0.3409
298.50	-0.081	224.5	-0.3409
298.53	-0.081	224.5	-0.3409
298.57	-0.081	224.5	-0.3409
298.60	-0.081	224.5	-0.3409
298.63	-0.08	224.5	-0.34
298.67	-0.08	224.5	-0.34
298.70	-0.08	224.5	-0.34
298.73	-0.08	224.5	-0.34
298.77	-0.079	224.5	-0.34
298.80	-0.079	224.5	-0.34
298.83	-0.079	224.5	-0.34
298.87	-0.078	224.5	-0.34
298.90	-0.078	224.5	-0.34
298.93	-0.078	224.5	-0.3391
298.97	-0.078	224.5	-0.3391
299.00	-0.077	224.6	-0.3391
299.03	-0.077	224.6	-0.3391
299.07	-0.077	224.6	-0.3391
299.10	-0.077	224.6	-0.3391
299.13	-0.076	224.6	-0.3391
299.17	-0.075	224.6	-0.3382
299.20	-0.075	224.6	-0.3382
299.23	-0.075	224.7	-0.3382

Prova triassiale ciclica SNME01-C3			
ensione di confinamento (kPa)		380	
deviatore ciclico (kPa)		80	
frequenza (hz)		0.00071429	
tempo	cella di carico	u	LVDT
(min)	kN	(kPa)	δ (mm)
299.28	-0.075	224.7	-0.3382
299.32	-0.074	224.7	-0.3382
299.33	-0.073	224.7	-0.3382
299.37	-0.073	224.7	-0.3373
299.40	-0.073	224.8	-0.3373
299.43	-0.073	224.8	-0.3373
299.47	-0.073	224.8	-0.3364
299.50	-0.072	224.8	-0.3364
299.53	-0.071	224.9	-0.3364
299.57	-0.071	224.9	-0.3364
299.60	-0.07	224.9	-0.3364
299.63	-0.07	224.9	-0.3355
299.67	-0.07	224.9	-0.3355
299.70	-0.069	225	-0.3346
299.73	-0.069	225	-0.3346
299.77	-0.069	225	-0.3346
299.80	-0.068	225	-0.3346
299.83	-0.067	225	-0.3338
299.87	-0.067	225.1	-0.3338
299.90	-0.067	225.1	-0.3338
299.93	-0.066	225.2	-0.3329
299.97	-0.066	225.2	-0.3329
300.00	-0.065	225.2	-0.332
300.03	-0.064	225.3	-0.332
300.07	-0.064	225.3	-0.332
300.10	-0.064	225.3	-0.3311
300.13	-0.063	225.4	-0.3311
300.17	-0.062	225.4	-0.3302
300.20	-0.062	225.4	-0.3302
300.23	-0.062	225.5	-0.3293
300.27	-0.06	225.6	-0.3293
300.30	-0.06	225.6	-0.3284
300.33	-0.06	225.6	-0.3284
300.37	-0.06	225.6	-0.3275
300.40	-0.059	225.7	-0.3267
300.43	-0.058	225.7	-0.3267
300.47	-0.058	225.8	-0.3258
300.50	-0.057	225.8	-0.3258
300.53	-0.056	225.8	-0.3249
300.57	-0.056	225.9	-0.3249
300.60	-0.055	225.9	-0.324
300.63	-0.054	226	-0.3231
300.67	-0.054	226	-0.3231
300.72	-0.053	226.1	-0.3213
300.75	-0.052	226.2	-0.3213
300.77	-0.053	226.2	-0.3204
300.80	-0.052	226.2	-0.3204
300.83	-0.051	226.3	-0.3204
300.87	-0.05	226.3	-0.3187
300.90	-0.05	226.4	-0.3187
300.93	-0.049	226.4	-0.3178
300.97	-0.048	226.5	-0.3169
301.00	-0.048	226.5	-0.316
301.03	-0.047	226.6	-0.3151
301.07	-0.046	226.7	-0.3151
301.10	-0.045	226.7	-0.3142
301.13	-0.045	226.8	-0.3133
301.17	-0.045	226.8	-0.3124

Prova triassiale ciclica SNME01-C3			
ensione di confinamento (kPa)		380	
deviatore ciclico (kPa)		80	
frequenza (hz)		0.00071429	
tempo	cella di carico	u	LVDT
(min)	kN	(kPa)	δ (mm)
301.20	-0.044	226.9	-0.3116
301.23	-0.043	227	-0.3107
301.27	-0.042	227.1	-0.3098
301.30	-0.041	227.1	-0.3098
301.33	-0.041	227.1	-0.3089
301.37	-0.041	227.2	-0.308
301.40	-0.04	227.3	-0.3062
301.43	-0.038	227.4	-0.3053
301.47	-0.039	227.4	-0.3045
301.50	-0.038	227.5	-0.3036
301.53	-0.036	227.6	-0.3036
301.57	-0.036	227.6	-0.3018
301.60	-0.036	227.7	-0.3009
301.63	-0.035	227.8	-0.2991
301.67	-0.034	227.9	-0.2982
301.70	-0.034	227.9	-0.2974
301.73	-0.033	228	-0.2956
301.77	-0.031	228.1	-0.2956
301.80	-0.031	228.1	-0.2938
301.83	-0.031	228.2	-0.2929
301.87	-0.03	228.3	-0.2911
301.90	-0.029	228.4	-0.2894
301.93	-0.028	228.5	-0.2876
301.97	-0.027	228.6	-0.2867
302.00	-0.026	228.7	-0.2867
302.03	-0.025	228.7	-0.284
302.07	-0.025	228.8	-0.2823
302.10	-0.025	228.8	-0.2814
302.13	-0.023	229	-0.2787
302.18	-0.023	229.1	-0.2778
302.22	-0.023	229.1	-0.2761
302.23	-0.022	229.2	-0.2743
302.27	-0.02	229.3	-0.2725
302.30	-0.02	229.4	-0.2707
302.33	-0.019	229.5	-0.2707
302.37	-0.018	229.5	-0.269
302.40	-0.018	229.6	-0.2672
302.43	-0.017	229.7	-0.2654
302.47	-0.016	229.8	-0.2627
302.50	-0.015	230	-0.2601
302.53	-0.014	230.1	-0.2583
302.57	-0.013	230.2	-0.2583
302.60	-0.013	230.2	-0.2548
302.63	-0.013	230.3	-0.253
302.67	-0.011	230.4	-0.2503
302.70	-0.01	230.5	-0.2468
302.73	-0.009	230.6	-0.2441
302.77	-0.009	230.7	-0.2414
302.80	-0.008	230.9	-0.2414
302.83	-0.007	230.9	-0.2388
302.87	-0.007	231	-0.2352
302.90	-0.006	231.1	-0.2317
302.93	-0.005	231.2	-0.2281
302.97	-0.004	231.3	-0.2255
303.00	-0.003	231.5	-0.2219
303.03	-0.001	231.6	-0.2219
303.07	-0.001	231.6	-0.2175
303.10	-0.001	231.7	-0.2139

Prova triassiale ciclica SNME01-C3			
pressione di confinamento (kPa)		380	
deviatore ciclico (kPa)		80	
frequenza (hz)		0.00071429	
tempo	cella di carico	u	LVDT
(min)	kN	(kPa)	δ (mm)
303.13	-0.001	231.8	-0.2095
303.17	0.001	232	-0.205
303.20	0.001	232.1	-0.2015
303.23	0.003	232.2	-0.1962
303.27	0.004	232.4	-0.1962
303.30	0.005	232.4	-0.1917
303.33	0.005	232.5	-0.1891
303.37	0.005	232.6	-0.1855
303.40	0.006	232.7	-0.182
303.43	0.007	232.8	-0.1784
303.47	0.008	232.9	-0.1713
303.50	0.009	233.1	-0.1713
303.53	0.01	233.1	-0.1651
303.57	0.01	233.3	-0.1598
303.60	0.011	233.4	-0.1544
303.65	0.012	233.5	-0.15
303.68	0.012	233.6	-0.1456
303.70	0.013	233.7	-0.1402
303.73	0.015	233.9	-0.1358
303.77	0.015	234	-0.1314
303.80	0.016	234.1	-0.1252
303.83	0.018	234.3	-0.1252
303.87	0.019	234.3	-0.1207
303.90	0.019	234.4	-0.1163
303.93	0.019	234.5	-0.1118
303.97	0.02	234.6	-0.1083
304.00	0.021	234.7	-0.1039
304.03	0.021	234.8	-0.1003
304.07	0.023	234.9	-0.1003
304.10	0.024	234.9	-0.0959
304.13	0.024	235	-0.0914
304.17	0.025	235.1	-0.0879
304.20	0.026	235.3	-0.0843
304.23	0.026	235.3	-0.0817
304.27	0.027	235.4	-0.0781
304.30	0.028	235.5	-0.0781
304.33	0.03	235.5	-0.0754
304.37	0.03	235.6	-0.0737
304.40	0.03	235.6	-0.0719
304.43	0.031	235.7	-0.0692
304.47	0.032	235.8	-0.0683
304.50	0.033	235.9	-0.0657
304.53	0.034	236	-0.0657
304.57	0.035	236	-0.0648
304.60	0.035	236.1	-0.063
304.63	0.036	236.1	-0.0612
304.67	0.037	236.2	-0.0604
304.70	0.037	236.3	-0.0595
304.73	0.038	236.4	-0.0568
304.77	0.039	236.4	-0.0568
304.80	0.04	236.4	-0.055
304.83	0.04	236.5	-0.0541
304.87	0.041	236.6	-0.0524
304.90	0.042	236.7	-0.0515
304.93	0.042	236.7	-0.0506
304.97	0.043	236.8	-0.0488
305.00	0.045	236.9	-0.0488
305.03	0.046	236.9	-0.0479

Prova triassiale ciclica SNME01-C3			
pressione di confinamento (kPa)		380	
deviatore ciclico (kPa)		80	
frequenza (hz)		0.00071429	
tempo	cella di carico	u	LVDT
(min)	kN	(kPa)	δ (mm)
305.08	0.046	237	-0.0453
305.12	0.046	237.1	-0.0453
305.13	0.048	237.1	-0.0444
305.17	0.048	237.2	-0.0435
305.20	0.048	237.2	-0.0426
305.23	0.049	237.4	-0.0408
305.27	0.05	237.4	-0.0399
305.30	0.051	237.5	-0.0391
305.33	0.052	237.6	-0.0391
305.37	0.052	237.6	-0.0373
305.40	0.052	237.7	-0.0364
305.43	0.053	237.8	-0.0355
305.47	0.054	237.9	-0.0337
305.50	0.055	237.9	-0.0328
305.53	0.055	238	-0.032
305.57	0.056	238.1	-0.032
305.60	0.057	238.1	-0.0302
305.63	0.057	238.2	-0.0293
305.67	0.058	238.2	-0.0284
305.70	0.059	238.3	-0.0266
305.73	0.059	238.4	-0.0257
305.77	0.06	238.5	-0.0249
305.80	0.061	238.6	-0.0249
305.83	0.062	238.6	-0.024
305.87	0.062	238.7	-0.0222
305.90	0.062	238.7	-0.0213
305.93	0.063	238.8	-0.0204
305.97	0.064	238.9	-0.0195
306.00	0.064	239	-0.0186
306.03	0.065	239.1	-0.0186
306.07	0.066	239.1	-0.0178
306.10	0.066	239.1	-0.0169
306.13	0.067	239.2	-0.0151
306.17	0.067	239.3	-0.0142
306.20	0.068	239.3	-0.0133
306.23	0.069	239.4	-0.0124
306.27	0.07	239.5	-0.0124
306.30	0.07	239.5	-0.0115
306.33	0.07	239.6	-0.0107
306.37	0.071	239.6	-0.0098
306.40	0.072	239.7	-0.0089
306.43	0.072	239.8	-0.008
306.47	0.073	239.9	-0.0071
306.50	0.073	239.9	-0.0071
306.55	0.074	240	-0.0053
306.58	0.074	240.1	-0.0044
306.60	0.075	240.1	-0.0044
306.63	0.076	240.1	-0.0036
306.67	0.076	240.2	-0.0027
306.70	0.076	240.3	-0.0027
306.73	0.077	240.4	-0.0009
306.77	0.077	240.4	-0.0009
306.80	0.077	240.5	0
306.83	0.078	240.5	0
306.87	0.079	240.5	0.0009
306.90	0.079	240.6	0.0018
306.93	0.079	240.7	0.0027
306.97	0.08	240.8	0.0036

Prova triassiale ciclica SNME01-C3			
ensione di confinamento (kPa)		380	
deviatore ciclico (kPa)		80	
frequenza (hz)		0.00071429	
tempo	cella di carico	u	LVDT
(min)	kN	(kPa)	δ (mm)
307.00	0.08	240.8	0.0036
307.03	0.081	240.9	0.0044
307.07	0.082	241	0.0044
307.10	0.083	241	0.0053
307.13	0.083	241	0.0062
307.17	0.082	241.1	0.0071
307.20	0.083	241.1	0.008
307.23	0.084	241.2	0.008
307.27	0.084	241.3	0.0089
307.30	0.084	241.3	0.0089
307.33	0.085	241.3	0.0098
307.37	0.085	241.4	0.0107
307.40	0.085	241.4	0.0107
307.43	0.086	241.5	0.0115
307.47	0.087	241.6	0.0124
307.50	0.087	241.7	0.0133
307.53	0.087	241.7	0.0133
307.57	0.088	241.7	0.0133
307.60	0.088	241.8	0.0142
307.63	0.088	241.8	0.0142
307.67	0.088	241.9	0.0151
307.70	0.089	241.9	0.016
307.73	0.089	242	0.016
307.77	0.09	242.1	0.016
307.80	0.09	242.1	0.0169
307.83	0.09	242.1	0.0169
307.87	0.09	242.2	0.0178
307.90	0.091	242.2	0.0186
307.93	0.091	242.3	0.0186
307.98	0.091	242.3	0.0195
308.02	0.091	242.4	0.0195
308.03	0.092	242.4	0.0204
308.07	0.092	242.5	0.0204
308.10	0.093	242.5	0.0204
308.13	0.091	242.5	0.0213
308.17	0.091	242.5	0.0213
308.20	0.093	242.6	0.0222
308.23	0.093	242.7	0.0222
308.27	0.093	242.7	0.0222
308.30	0.094	242.8	0.0231
308.33	0.094	242.8	0.0231
308.37	0.094	242.8	0.0231
308.40	0.094	242.8	0.024
308.43	0.094	242.9	0.024
308.47	0.094	242.9	0.024
308.50	0.094	242.9	0.0249
308.53	0.094	243	0.0249
308.57	0.095	243	0.0249
308.60	0.095	243	0.0249
308.63	0.095	243	0.0257
308.67	0.096	243.1	0.0257
308.70	0.095	243.1	0.0257
308.73	0.095	243.2	0.0266
308.77	0.095	243.2	0.0266
308.80	0.095	243.2	0.0266
308.83	0.096	243.2	0.0266
308.87	0.096	243.3	0.0275
308.90	0.096	243.3	0.0275

Prova triassiale ciclica SNME01-C3			
ensione di confinamento (kPa)		380	
deviatore ciclico (kPa)		80	
frequenza (hz)		0.00071429	
tempo	cella di carico	u	LVDT
(min)	kN	(kPa)	δ (mm)
308.93	0.096	243.3	0.0275
308.97	0.096	243.4	0.0284
309.00	0.094	243.3	0.0275
309.03	0.095	243.4	0.0275
309.07	0.096	243.4	0.0275
309.10	0.096	243.5	0.0284
309.13	0.096	243.5	0.0284
309.17	0.095	243.5	0.0284
309.20	0.095	243.5	0.0284
309.23	0.097	243.6	0.0293
309.27	0.096	243.6	0.0293
309.30	0.096	243.6	0.0293
309.33	0.096	243.6	0.0293
309.37	0.096	243.7	0.0293
309.40	0.096	243.7	0.0293
309.45	0.096	243.7	0.0293
309.48	0.097	243.8	0.0302
309.50	0.097	243.8	0.0302
309.53	0.096	243.8	0.0302
309.57	0.093	243.7	0.0293
309.60	0.094	243.8	0.0293
309.63	0.096	243.8	0.0293
309.67	0.096	243.8	0.0302
309.70	0.095	243.9	0.0302
309.73	0.095	243.9	0.0302
309.77	0.094	243.9	0.0302
309.80	0.094	243.9	0.0302
309.83	0.094	243.9	0.0302
309.87	0.095	243.9	0.0302
309.90	0.095	243.9	0.0302
309.93	0.094	243.9	0.0302
309.97	0.094	244	0.0302
310.00	0.096	244	0.0302
310.03	0.094	244	0.0302
310.07	0.093	244	0.0302
310.10	0.093	244	0.0302
310.13	0.093	244	0.0302
310.17	0.093	244	0.0302
310.20	0.093	244	0.0302
310.23	0.09	243.9	0.0293
310.27	0.091	244	0.0293
310.30	0.093	244.1	0.0293
310.33	0.093	244.1	0.0302
310.37	0.093	244.1	0.0302
310.40	0.092	244.1	0.0293
310.43	0.088	244	0.0284
310.47	0.09	244.1	0.0302
310.50	0.092	244.1	0.0302
310.53	0.091	244.1	0.0302
310.57	0.089	244.1	0.0293
310.60	0.089	244.1	0.0293
310.63	0.09	244.1	0.0293
310.67	0.089	244.1	0.0293
310.70	0.089	244.1	0.0284
310.73	0.089	244.1	0.0284
310.77	0.086	244	0.0284
310.80	0.089	244.1	0.0275
310.83	0.089	244.1	0.0284

Prova triassiale ciclica SNME01-C3			
ensione di confinamento (kPa)		380	
deviatore ciclico (kPa)		80	
frequenza (hz)		0.00071429	
tempo	cella di carico	u	LVDT
(min)	kN	(kPa)	δ (mm)
310.87	0.088	244.1	0.0284
310.92	0.086	244	0.0284
310.93	0.086	244	0.0284
310.97	0.085	244	0.0275
311.00	0.086	244	0.0275
311.03	0.086	244	0.0275
311.07	0.085	244	0.0275
311.10	0.084	244	0.0275
311.13	0.083	244	0.0275
311.17	0.083	244	0.0266
311.20	0.083	244	0.0266
311.23	0.083	244	0.0266
311.27	0.082	244	0.0266
311.30	0.081	243.9	0.0257
311.33	0.081	243.9	0.0257
311.37	0.081	243.9	0.0257
311.40	0.081	243.9	0.0257
311.43	0.08	243.9	0.0257
311.47	0.079	243.9	0.0257
311.50	0.079	243.9	0.0249
311.53	0.077	243.8	0.0249
311.57	0.078	243.8	0.0249
311.60	0.078	243.8	0.0249
311.63	0.078	243.8	0.024
311.67	0.078	243.8	0.024
311.70	0.075	243.7	0.024
311.73	0.076	243.8	0.024
311.77	0.076	243.7	0.0231
311.80	0.074	243.7	0.0231
311.83	0.073	243.7	0.0222
311.87	0.073	243.7	0.0222
311.90	0.073	243.7	0.0222
311.93	0.073	243.6	0.0222
311.97	0.072	243.6	0.0213
312.00	0.071	243.6	0.0213
312.03	0.071	243.5	0.0213
312.07	0.07	243.5	0.0204
312.10	0.07	243.5	0.0204
312.13	0.069	243.5	0.0195
312.17	0.068	243.4	0.0195
312.20	0.068	243.4	0.0195
312.23	0.067	243.4	0.0186
312.27	0.067	243.3	0.0186
312.30	0.063	243.2	0.0169
312.35	0.066	243.3	0.0178
312.38	0.066	243.3	0.0178
312.40	0.064	243.2	0.0169
312.43	0.064	243.2	0.016
312.47	0.064	243.2	0.016
312.50	0.062	243.2	0.0151
312.53	0.062	243.2	0.0151
312.57	0.061	243.1	0.0142
312.60	0.06	243	0.0142
312.63	0.06	243	0.0133
312.67	0.06	243	0.0133
312.70	0.057	243	0.0124
312.73	0.059	243	0.0124
312.77	0.055	242.8	0.0107

Prova triassiale ciclica SNME01-C3			
pressione di confinamento (kPa)		380	
deviatore ciclico (kPa)		80	
frequenza (hz)		0.00071429	
tempo	cella di carico	u	LVDT
(min)	kN	(kPa)	δ (mm)
312.80	0.058	242.9	0.0115
312.83	0.057	242.9	0.0115
312.87	0.055	242.8	0.0107
312.90	0.055	242.8	0.0098
312.93	0.055	242.8	0.0089
312.97	0.054	242.7	0.0089
313.00	0.052	242.7	0.008
313.03	0.051	242.6	0.0071
313.07	0.051	242.6	0.0071
313.10	0.051	242.5	0.0062
313.13	0.051	242.5	0.0053
313.17	0.049	242.5	0.0044
313.20	0.048	242.4	0.0044
313.23	0.044	242.3	0.0027
313.27	0.049	242.4	0.0036
313.30	0.046	242.2	0.0036
313.33	0.047	242.3	0.0018
313.37	0.047	242.3	0.0018
313.40	0.045	242.2	0
313.43	0.042	242.1	-0.0009
313.47	0.041	242	-0.0018
313.50	0.043	242	-0.0018
313.53	0.041	242	-0.0018
313.57	0.04	241.9	-0.0027
313.60	0.04	241.9	-0.0036
313.63	0.039	241.9	-0.0044
313.67	0.038	241.8	-0.0053
313.70	0.037	241.7	-0.0071
313.73	0.036	241.6	-0.008
313.77	0.035	241.6	-0.008
313.82	0.035	241.6	-0.0089
313.85	0.033	241.4	-0.0107
313.87	0.034	241.4	-0.0107
313.90	0.031	241.3	-0.0115
313.93	0.031	241.3	-0.0124
313.97	0.033	241.3	-0.0124
314.00	0.032	241.2	-0.0133
314.03	0.03	241.2	-0.016
314.07	0.028	241	-0.016
314.10	0.028	241	-0.016
314.13	0.026	240.9	-0.0178
314.17	0.026	240.9	-0.0186
314.20	0.024	240.9	-0.0195
314.23	0.025	240.8	-0.0213
314.27	0.023	240.6	-0.0222
314.30	0.024	240.7	-0.0222
314.33	0.022	240.6	-0.0222
314.37	0.022	240.5	-0.024
314.40	0.022	240.5	-0.0249
314.43	0.021	240.5	-0.0257
314.47	0.021	240.5	-0.0266
314.50	0.017	240.3	-0.0293
314.53	0.017	240.2	-0.0302
314.57	0.017	240.1	-0.0302
314.60	0.017	240.1	-0.0311
314.63	0.017	240.1	-0.032
314.67	0.016	240	-0.0328
314.70	0.013	239.8	-0.0355

Prova triassiale ciclica SNME01-C3			
pressione di confinamento (kPa)		380	
deviatore ciclico (kPa)		80	
frequenza (hz)		0.00071429	
tempo	cella di carico	u	LVDT
(min)	kN	(kPa)	δ (mm)
314.73	0.011	239.7	-0.0364
314.77	0.013	239.8	-0.0364
314.80	0.012	239.7	-0.0364
314.83	0.009	239.6	-0.0373
314.87	0.009	239.6	-0.0391
314.90	0.008	239.5	-0.0408
314.93	0.009	239.5	-0.0408
314.97	0.009	239.5	-0.0417
315.00	0.007	239.3	-0.0444
315.03	0.002	239.1	-0.0444
315.07	0.006	239.2	-0.0462
315.10	0.006	239.2	-0.0462
315.13	0.004	239.1	-0.0479
315.17	0.002	238.9	-0.0497
315.20	0.001	238.8	-0.0506
315.25	0	238.7	-0.0515
315.28	0.001	238.7	-0.0524
315.30	-0.001	238.7	-0.0541
315.33	-0.001	238.6	-0.055
315.37	-0.003	238.4	-0.055
315.40	-0.005	238.4	-0.0559
315.43	-0.005	238.4	-0.0586
315.47	-0.004	238.3	-0.0595
315.50	-0.005	238.2	-0.0604
315.53	-0.007	238.1	-0.0621
315.57	-0.007	238	-0.0639
315.60	-0.008	237.9	-0.0639
315.63	-0.01	237.8	-0.0657
315.67	-0.01	237.8	-0.0675
315.70	-0.01	237.8	-0.0692
315.73	-0.011	237.6	-0.0728
315.77	-0.012	237.4	-0.0772
315.80	-0.013	237.3	-0.0799
315.83	-0.016	237.1	-0.0799
315.87	-0.015	237.1	-0.0843
315.90	-0.015	237.1	-0.087
315.93	-0.016	237	-0.0914
315.97	-0.017	236.9	-0.0959
316.00	-0.018	236.8	-0.1012
316.03	-0.019	236.7	-0.1074
316.07	-0.019	236.5	-0.1074
316.10	-0.02	236.4	-0.1136
316.13	-0.02	236.4	-0.1216
316.17	-0.02	236.3	-0.1331
316.20	-0.022	236.1	-0.1473
316.23	-0.023	235.8	-0.1651
316.27	-0.024	235.7	-0.1775
316.30	-0.025	235.5	-0.1775
316.33	-0.025	235.3	-0.1864
316.37	-0.025	235.3	-0.1926
316.40	-0.027	235.2	-0.1988
316.43	-0.028	235	-0.2042
316.47	-0.028	234.9	-0.2068
316.50	-0.029	234.7	-0.2113
316.53	-0.031	234.5	-0.2113
316.57	-0.031	234.5	-0.2148
316.60	-0.031	234.5	-0.2166
316.63	-0.032	234.3	-0.2201

Prova triassiale ciclica SNME01-C3			
pressione di confinamento (kPa)		380	
deviatore ciclico (kPa)		80	
frequenza (hz)		0.00071429	
tempo	cella di carico	u	LVDT
(min)	kN	(kPa)	δ (mm)
316.67	-0.033	234.2	-0.2228
316.72	-0.033	234.1	-0.2255
316.75	-0.034	234	-0.2281
316.77	-0.035	233.9	-0.2299
316.80	-0.036	233.8	-0.2326
316.83	-0.036	233.7	-0.2352
316.87	-0.037	233.5	-0.2352
316.90	-0.038	233.4	-0.2379
316.93	-0.038	233.4	-0.2397
316.97	-0.039	233.3	-0.2423
317.00	-0.04	233.2	-0.245
317.03	-0.041	233	-0.2468
317.07	-0.042	232.9	-0.2485
317.10	-0.042	232.8	-0.2485
317.13	-0.043	232.7	-0.2494
317.17	-0.043	232.7	-0.2503
317.20	-0.044	232.6	-0.253
317.23	-0.045	232.4	-0.2565
317.27	-0.045	232.4	-0.2583
317.30	-0.046	232.3	-0.261
317.33	-0.048	232.1	-0.261
317.37	-0.048	232	-0.2636
317.40	-0.048	232	-0.2654
317.43	-0.049	231.9	-0.2663
317.47	-0.048	231.8	-0.269
317.50	-0.05	231.7	-0.2698
317.53	-0.051	231.6	-0.2716
317.57	-0.051	231.5	-0.2716
317.60	-0.052	231.4	-0.2734
317.63	-0.052	231.4	-0.2752
317.67	-0.053	231.2	-0.2778
317.70	-0.055	231	-0.2796
317.73	-0.054	231	-0.2805
317.77	-0.054	231	-0.2823
317.80	-0.056	230.8	-0.2823
317.83	-0.057	230.7	-0.284
317.87	-0.057	230.7	-0.2867
317.90	-0.057	230.6	-0.2876
317.93	-0.058	230.4	-0.2894
317.97	-0.058	230.4	-0.2903
318.00	-0.059	230.3	-0.292
318.03	-0.06	230.2	-0.292
318.07	-0.061	230	-0.2929
318.10	-0.061	230	-0.2947
318.15	-0.061	229.9	-0.2965
318.18	-0.062	229.8	-0.2974
318.20	-0.062	229.8	-0.2982
318.23	-0.063	229.7	-0.2991
318.27	-0.063	229.6	-0.3
318.30	-0.064	229.5	-0.3018
318.33	-0.064	229.4	-0.3027
318.37	-0.064	229.3	-0.3027
318.40	-0.066	229.2	-0.3045
318.43	-0.066	229.2	-0.3053
318.47	-0.066	229.1	-0.3062
318.50	-0.066	229	-0.3071
318.53	-0.067	228.9	-0.3089
318.57	-0.068	228.8	-0.3098

Prova triassiale ciclica SNME01-C3			
pressione di confinamento (kPa)		380	
deviatore ciclico (kPa)		80	
frequenza (hz)		0.00071429	
tempo	cella di carico	u	LVDT
(min)	kN	(kPa)	δ (mm)
318.60	-0.068	228.7	-0.3098
318.63	-0.069	228.7	-0.3107
318.67	-0.069	228.7	-0.3116
318.70	-0.069	228.6	-0.3124
318.73	-0.07	228.5	-0.3133
318.77	-0.071	228.4	-0.3151
318.80	-0.071	228.3	-0.3151
318.83	-0.071	228.2	-0.3151
318.87	-0.072	228.1	-0.316
318.90	-0.072	228.1	-0.3178
318.93	-0.072	228.1	-0.3187
318.97	-0.073	228	-0.3187
319.00	-0.073	227.9	-0.3196
319.03	-0.074	227.8	-0.3204
319.07	-0.074	227.8	-0.3204
319.10	-0.075	227.7	-0.3213
319.13	-0.075	227.7	-0.3222
319.17	-0.075	227.6	-0.3231
319.20	-0.075	227.5	-0.324
319.23	-0.075	227.5	-0.324
319.27	-0.076	227.4	-0.3258
319.30	-0.077	227.3	-0.3258
319.33	-0.077	227.2	-0.3258
319.37	-0.077	227.2	-0.3267
319.40	-0.077	227.2	-0.3275
319.43	-0.078	227.1	-0.3275
319.47	-0.078	227.1	-0.3284
319.50	-0.078	227	-0.3293
319.53	-0.079	226.9	-0.3293
319.57	-0.079	226.9	-0.3302
319.62	-0.079	226.8	-0.3302
319.65	-0.079	226.8	-0.3302
319.67	-0.08	226.7	-0.3311
319.70	-0.08	226.7	-0.3311
319.73	-0.08	226.6	-0.3329
319.77	-0.08	226.6	-0.3329
319.80	-0.081	226.5	-0.3329
319.83	-0.081	226.5	-0.3338
319.87	-0.081	226.4	-0.3338
319.90	-0.081	226.4	-0.3346
319.93	-0.081	226.4	-0.3346
319.97	-0.082	226.3	-0.3346
320.00	-0.082	226.3	-0.3355
320.03	-0.082	226.3	-0.3355
320.07	-0.082	226.2	-0.3364
320.10	-0.082	226.1	-0.3364
320.13	-0.083	226.1	-0.3364
320.17	-0.083	226.1	-0.3373
320.20	-0.083	226.1	-0.3373
320.23	-0.083	226	-0.3382
320.27	-0.083	226	-0.3382
320.30	-0.083	225.9	-0.3382
320.33	-0.083	225.9	-0.3382
320.37	-0.083	225.9	-0.3391
320.40	-0.083	225.9	-0.3391
320.43	-0.083	225.8	-0.3391
320.47	-0.084	225.8	-0.34
320.50	-0.084	225.7	-0.34

Prova triassiale ciclica SNME01-C3			
pressione di confinamento (kPa)		380	
deviatore ciclico (kPa)		80	
frequenza (hz)		0.00071429	
tempo	cella di carico	u	LVDT
(min)	kN	(kPa)	δ (mm)
320.53	-0.084	225.7	-0.34
320.57	-0.084	225.7	-0.34
320.60	-0.084	225.6	-0.34
320.63	-0.084	225.6	-0.3409
320.67	-0.084	225.6	-0.3409
320.70	-0.084	225.6	-0.3409
320.73	-0.084	225.6	-0.3409
320.77	-0.084	225.5	-0.3417
320.80	-0.084	225.5	-0.3417
320.83	-0.084	225.5	-0.3417
320.87	-0.084	225.5	-0.3417
320.90	-0.084	225.5	-0.3417
320.93	-0.084	225.4	-0.3417
320.97	-0.084	225.4	-0.3417
321.00	-0.084	225.4	-0.3426
321.03	-0.084	225.4	-0.3426
321.08	-0.084	225.3	-0.3426
321.12	-0.084	225.3	-0.3426
321.13	-0.084	225.3	-0.3426
321.17	-0.084	225.3	-0.3426
321.20	-0.084	225.3	-0.3426
321.23	-0.084	225.3	-0.3426
321.27	-0.084	225.3	-0.3426
321.30	-0.084	225.3	-0.3426
321.33	-0.084	225.2	-0.3426
321.37	-0.084	225.2	-0.3426
321.40	-0.084	225.2	-0.3426
321.43	-0.084	225.2	-0.3435
321.47	-0.083	225.2	-0.3426
321.50	-0.083	225.2	-0.3426
321.53	-0.083	225.2	-0.3426
321.57	-0.083	225.2	-0.3426
321.60	-0.083	225.2	-0.3426
321.63	-0.082	225.2	-0.3426
321.67	-0.082	225.2	-0.3426
321.70	-0.082	225.2	-0.3426
321.73	-0.082	225.2	-0.3426
321.77	-0.082	225.2	-0.3426
321.80	-0.082	225.2	-0.3426
321.83	-0.081	225.2	-0.3426
321.87	-0.081	225.2	-0.3426
321.90	-0.081	225.2	-0.3426
321.93	-0.081	225.2	-0.3426
321.97	-0.08	225.2	-0.3426
322.00	-0.08	225.2	-0.3426
322.03	-0.08	225.2	-0.3426
322.07	-0.079	225.2	-0.3417
322.10	-0.079	225.2	-0.3417
322.13	-0.079	225.2	-0.3426
322.17	-0.079	225.2	-0.3417
322.20	-0.078	225.2	-0.3417
322.23	-0.078	225.2	-0.3417
322.27	-0.078	225.2	-0.3417
322.30	-0.078	225.2	-0.3409
322.33	-0.077	225.3	-0.3409
322.37	-0.077	225.3	-0.3409
322.40	-0.076	225.3	-0.3409
322.43	-0.076	225.3	-0.3409

Prova triassiale ciclica SNME01-C3			
ensione di confinamento (kPa)		380	
deviatore ciclico (kPa)		80	
frequenza (hz)		0.00071429	
tempo	cella di carico	u	LVDT
(min)	kN	(kPa)	δ (mm)
322.47	-0.076	225.3	-0.3409
322.52	-0.076	225.3	-0.3409
322.55	-0.076	225.3	-0.34
322.57	-0.075	225.3	-0.34
322.60	-0.074	225.4	-0.34
322.63	-0.074	225.4	-0.34
322.67	-0.074	225.4	-0.34
322.70	-0.074	225.4	-0.3391
322.73	-0.073	225.4	-0.3391
322.77	-0.073	225.5	-0.3391
322.80	-0.072	225.5	-0.3382
322.83	-0.072	225.5	-0.3382
322.87	-0.072	225.5	-0.3382
322.90	-0.07	225.6	-0.3382
322.93	-0.07	225.6	-0.3373
322.97	-0.071	225.6	-0.3373
323.00	-0.07	225.6	-0.3373
323.03	-0.069	225.6	-0.3364
323.07	-0.069	225.6	-0.3364
323.10	-0.068	225.7	-0.3355
323.13	-0.068	225.7	-0.3355
323.17	-0.068	225.7	-0.3355
323.20	-0.068	225.7	-0.3355
323.23	-0.067	225.8	-0.3346
323.27	-0.066	225.8	-0.3338
323.30	-0.066	225.8	-0.3338
323.33	-0.065	225.9	-0.3329
323.37	-0.064	226	-0.3329
323.40	-0.064	226	-0.3329
323.43	-0.064	226	-0.3329
323.47	-0.063	226	-0.332
323.50	-0.062	226.1	-0.3311
323.53	-0.062	226.1	-0.3311
323.57	-0.061	226.2	-0.3302
323.60	-0.06	226.2	-0.3302
323.63	-0.06	226.2	-0.3293
323.67	-0.06	226.3	-0.3293
323.70	-0.06	226.3	-0.3284
323.73	-0.059	226.3	-0.3284
323.77	-0.058	226.4	-0.3275
323.80	-0.057	226.5	-0.3267
323.83	-0.057	226.5	-0.3267
323.87	-0.057	226.5	-0.3267
323.90	-0.056	226.5	-0.3258
323.93	-0.055	226.6	-0.3249
323.98	-0.054	226.7	-0.3249
324.02	-0.054	226.7	-0.324
324.03	-0.054	226.7	-0.324
324.07	-0.052	226.8	-0.3222
324.10	-0.053	226.8	-0.3222
324.13	-0.052	226.9	-0.3213
324.17	-0.05	227	-0.3213
324.20	-0.05	227	-0.3204
324.23	-0.05	227.1	-0.3196
324.27	-0.05	227.1	-0.3196
324.30	-0.048	227.2	-0.3187
324.33	-0.048	227.2	-0.3178
324.37	-0.047	227.3	-0.3169

Prova triassiale ciclica SNME01-C3			
pressione di confinamento (kPa)		380	
deviatore ciclico (kPa)		80	
frequenza (hz)		0.00071429	
tempo	cella di carico	u	LVDT
(min)	kN	(kPa)	δ (mm)
324.40	-0.046	227.4	-0.3169
324.43	-0.046	227.4	-0.316
324.47	-0.046	227.4	-0.3151
324.50	-0.044	227.6	-0.3133
324.53	-0.044	227.6	-0.3133
324.57	-0.043	227.7	-0.3116
324.60	-0.043	227.7	-0.3107
324.63	-0.041	227.9	-0.3107
324.67	-0.041	227.9	-0.3098
324.70	-0.041	227.9	-0.3089
324.73	-0.04	228	-0.308
324.77	-0.039	228.1	-0.3062
324.80	-0.038	228.1	-0.3062
324.83	-0.038	228.2	-0.3045
324.87	-0.036	228.3	-0.3045
324.90	-0.036	228.3	-0.3036
324.93	-0.036	228.4	-0.3018
324.97	-0.035	228.4	-0.3
325.00	-0.034	228.6	-0.2991
325.03	-0.033	228.6	-0.2974
325.07	-0.032	228.8	-0.2956
325.10	-0.031	228.9	-0.2956
325.13	-0.031	228.9	-0.2947
325.17	-0.031	228.9	-0.2938
325.20	-0.03	229	-0.2911
325.23	-0.028	229.2	-0.2903
325.27	-0.029	229.2	-0.2885
325.30	-0.028	229.3	-0.2867
325.33	-0.026	229.4	-0.2867
325.37	-0.026	229.4	-0.284
325.42	-0.025	229.6	-0.2814
325.45	-0.024	229.6	-0.2814
325.47	-0.023	229.6	-0.2796
325.50	-0.023	229.7	-0.2778
325.53	-0.023	229.8	-0.2761
325.57	-0.02	230	-0.2734
325.60	-0.021	230.1	-0.2725
325.63	-0.02	230.2	-0.2707
325.67	-0.018	230.3	-0.2707
325.70	-0.017	230.3	-0.2681
325.73	-0.017	230.4	-0.2663
325.77	-0.017	230.5	-0.2645
325.80	-0.016	230.6	-0.2619
325.83	-0.015	230.7	-0.2592
325.87	-0.015	230.8	-0.2574
325.90	-0.013	230.9	-0.2574
325.93	-0.012	230.9	-0.2539
325.97	-0.012	231	-0.2512
326.00	-0.012	231.1	-0.2494
326.03	-0.01	231.3	-0.2459
326.07	-0.01	231.4	-0.2432
326.10	-0.009	231.5	-0.2406
326.13	-0.007	231.6	-0.2406
326.17	-0.007	231.6	-0.237
326.20	-0.007	231.7	-0.2352
326.23	-0.006	231.8	-0.2317
326.27	-0.005	232	-0.2272
326.30	-0.004	232	-0.2246

Prova triassiale ciclica SNME01-C3			
pressione di confinamento (kPa)		380	
deviatore ciclico (kPa)		80	
frequenza (hz)		0.00071429	
tempo	cella di carico	u	LVDT
(min)	kN	(kPa)	δ (mm)
326.33	-0.003	232.2	-0.2201
326.37	-0.002	232.3	-0.2201
326.40	-0.002	232.3	-0.2166
326.43	-0.001	232.4	-0.213
326.47	0	232.6	-0.2095
326.50	0.001	232.7	-0.205
326.53	0.001	232.8	-0.2015
326.57	0.002	232.9	-0.1971
326.60	0.005	233.1	-0.1971
326.63	0.005	233.1	-0.1926
326.67	0.004	233.2	-0.1882
326.70	0.005	233.3	-0.1846
326.73	0.007	233.5	-0.1802
326.77	0.007	233.6	-0.1766
326.80	0.009	233.7	-0.1731
326.83	0.009	233.8	-0.1731
326.88	0.009	234	-0.1598
326.92	0.011	234.1	-0.1544
326.93	0.012	234.2	-0.1544
326.97	0.013	234.2	-0.1491
327.00	0.013	234.3	-0.1429
327.03	0.014	234.5	-0.1385
327.07	0.015	234.6	-0.1331
327.10	0.015	234.7	-0.1287
327.13	0.016	234.8	-0.1243
327.17	0.019	235	-0.1243
327.20	0.018	235	-0.1189
327.23	0.018	235.1	-0.1154
327.27	0.018	235.2	-0.111
327.30	0.021	235.3	-0.1065
327.33	0.02	235.4	-0.103
327.37	0.022	235.5	-0.0985
327.40	0.024	235.7	-0.0985
327.43	0.024	235.7	-0.095
327.47	0.024	235.7	-0.0914
327.50	0.024	235.8	-0.0879
327.53	0.026	236	-0.0843
327.57	0.027	236	-0.0817
327.60	0.025	236	-0.079
327.63	0.03	236.2	-0.079
327.67	0.029	236.2	-0.0763
327.70	0.029	236.3	-0.0737
327.73	0.03	236.3	-0.0728
327.77	0.031	236.4	-0.071
327.80	0.032	236.5	-0.0692
327.83	0.033	236.6	-0.0675
327.87	0.035	236.7	-0.0675
327.90	0.035	236.7	-0.0657
327.93	0.035	236.7	-0.0648
327.97	0.035	236.8	-0.063
328.00	0.037	236.9	-0.0612
328.03	0.037	236.9	-0.0604
328.07	0.038	237	-0.0595
328.10	0.039	237.1	-0.0595
328.13	0.04	237.1	-0.0568
328.17	0.04	237.2	-0.0559
328.20	0.042	237.3	-0.0541
328.23	0.042	237.4	-0.0533

Prova triassiale ciclica SNME01-C3			
pressione di confinamento (kPa)		380	
deviatore ciclico (kPa)		80	
frequenza (hz)		0.00071429	
tempo	cella di carico	u	LVDT
(min)	kN	(kPa)	δ (mm)
328.27	0.042	237.5	-0.0515
328.30	0.043	237.5	-0.0506
328.35	0.044	237.6	-0.0497
328.37	0.045	237.7	-0.0488
328.40	0.045	237.7	-0.047
328.43	0.048	237.8	-0.047
328.47	0.047	237.8	-0.0462
328.50	0.047	237.9	-0.0453
328.53	0.048	238	-0.0435
328.57	0.05	238.1	-0.0426
328.60	0.05	238.2	-0.0408
328.63	0.05	238.2	-0.0399
328.67	0.052	238.3	-0.0399
328.70	0.052	238.3	-0.0391
328.73	0.052	238.4	-0.0382
328.77	0.053	238.5	-0.0364
328.80	0.054	238.6	-0.0355
328.83	0.055	238.7	-0.0346
328.87	0.056	238.7	-0.0328
328.90	0.056	238.8	-0.0328
328.93	0.057	238.8	-0.032
328.97	0.057	238.9	-0.0311
329.00	0.058	239	-0.0302
329.03	0.059	239	-0.0293
329.07	0.06	239.1	-0.0275
329.10	0.06	239.2	-0.0266
329.13	0.061	239.3	-0.0266
329.17	0.061	239.3	-0.0257
329.20	0.061	239.4	-0.0249
329.23	0.062	239.4	-0.024
329.27	0.063	239.5	-0.0222
329.30	0.064	239.6	-0.0213
329.33	0.065	239.7	-0.0204
329.37	0.065	239.8	-0.0204
329.40	0.066	239.8	-0.0195
329.43	0.066	239.8	-0.0186
329.47	0.066	239.9	-0.0178
329.50	0.068	240	-0.0169
329.53	0.068	240	-0.016
329.57	0.069	240.1	-0.0151
329.60	0.069	240.2	-0.0151
329.63	0.07	240.2	-0.0142
329.67	0.07	240.3	-0.0133
329.70	0.071	240.3	-0.0115
329.73	0.072	240.4	-0.0107
329.78	0.071	240.5	-0.0107
329.82	0.072	240.5	-0.0098
329.83	0.074	240.6	-0.008
329.87	0.074	240.7	-0.008
329.90	0.074	240.8	-0.0071
329.93	0.075	240.8	-0.0071
329.97	0.075	240.8	-0.0062
330.00	0.075	240.9	-0.0053
330.03	0.076	241	-0.0044
330.07	0.078	241	-0.0036
330.10	0.077	241.1	-0.0027
330.13	0.077	241.2	-0.0018
330.17	0.078	241.2	-0.0018

Prova triassiale ciclica SNME01-C3			
ensione di confinamento (kPa)		380	
deviatore ciclico (kPa)		80	
frequenza (hz)		0.00071429	
tempo	cella di carico	u	LVDT
(min)	kN	(kPa)	δ (mm)
330.20	0.079	241.2	-0.0009
330.23	0.079	241.3	0
330.27	0.08	241.4	0.0009
330.30	0.08	241.4	0.0009
330.33	0.081	241.5	0.0018
330.37	0.081	241.6	0.0027
330.40	0.081	241.7	0.0027
330.43	0.082	241.7	0.0036
330.47	0.082	241.7	0.0044
330.50	0.083	241.8	0.0053
330.53	0.083	241.9	0.0053
330.57	0.083	241.9	0.0062
330.60	0.084	242	0.0071
330.63	0.085	242.1	0.0071
330.67	0.085	242.1	0.008
330.70	0.085	242.1	0.008
330.73	0.085	242.2	0.0089
330.77	0.086	242.2	0.0098
330.80	0.086	242.3	0.0107
330.83	0.087	242.4	0.0107
330.87	0.088	242.4	0.0107
330.90	0.087	242.4	0.0115
330.93	0.087	242.5	0.0115
330.97	0.088	242.5	0.0124
331.00	0.089	242.6	0.0133
331.03	0.089	242.6	0.0133
331.07	0.089	242.7	0.0142
331.10	0.09	242.8	0.0142
331.13	0.09	242.8	0.0151
331.17	0.09	242.8	0.0151
331.20	0.091	242.8	0.016
331.25	0.09	242.9	0.016
331.28	0.09	242.9	0.0169
331.30	0.09	243	0.0169
331.33	0.092	243	0.0178
331.37	0.092	243.1	0.0178
331.40	0.092	243.1	0.0186
331.43	0.092	243.2	0.0186
331.47	0.093	243.2	0.0186
331.50	0.093	243.3	0.0195
331.53	0.092	243.3	0.0195
331.57	0.093	243.3	0.0204
331.60	0.094	243.4	0.0213
331.63	0.094	243.4	0.0213
331.67	0.093	243.5	0.0213
331.70	0.094	243.5	0.0213
331.73	0.094	243.5	0.0213
331.77	0.094	243.5	0.0222
331.80	0.095	243.6	0.0222
331.83	0.094	243.6	0.0231
331.87	0.094	243.7	0.0231
331.90	0.095	243.7	0.0231
331.93	0.095	243.7	0.0231
331.97	0.095	243.7	0.0231
332.00	0.095	243.8	0.024
332.03	0.095	243.8	0.024
332.07	0.095	243.9	0.024
332.10	0.095	243.9	0.0249

Prova triassiale ciclica SNME01-C3			
ensione di confinamento (kPa)		380	
deviatore ciclico (kPa)		80	
frequenza (hz)		0.00071429	
tempo	cella di carico	u	LVDT
(min)	kN	(kPa)	δ (mm)
332.13	0.095	243.9	0.0249
332.17	0.096	243.9	0.0249
332.20	0.096	244	0.0249
332.23	0.096	244	0.0249
332.27	0.095	244	0.0249
332.30	0.094	244	0.0249
332.33	0.095	244.1	0.0257
332.37	0.096	244.1	0.0257
332.40	0.096	244.1	0.0266
332.43	0.096	244.2	0.0257
332.47	0.096	244.2	0.0257
332.50	0.096	244.2	0.0266
332.53	0.095	244.2	0.0266
332.57	0.098	244.3	0.0266
332.60	0.094	244.3	0.0266
332.63	0.095	244.3	0.0266
332.68	0.095	244.3	0.0275
332.72	0.096	244.4	0.0275
332.73	0.096	244.4	0.0275
332.77	0.096	244.4	0.0275
332.80	0.095	244.4	0.0275
332.83	0.095	244.4	0.0275
332.87	0.098	244.5	0.0284
332.90	0.097	244.5	0.0275
332.93	0.095	244.5	0.0275
332.97	0.095	244.5	0.0275
333.00	0.095	244.5	0.0275
333.03	0.095	244.6	0.0275
333.07	0.095	244.6	0.0275
333.10	0.095	244.6	0.0275
333.13	0.095	244.6	0.0275
333.17	0.094	244.6	0.0275
333.20	0.093	244.6	0.0275
333.23	0.093	244.6	0.0275
333.27	0.093	244.6	0.0275
333.30	0.094	244.6	0.0275
333.33	0.094	244.7	0.0275
333.37	0.096	244.8	0.0284
333.40	0.094	244.7	0.0284
333.43	0.091	244.7	0.0275
333.47	0.091	244.6	0.0275
333.50	0.092	244.7	0.0275
333.53	0.093	244.7	0.0275
333.57	0.093	244.7	0.0275
333.60	0.092	244.7	0.0275
333.63	0.091	244.7	0.0275
333.67	0.091	244.7	0.0275
333.70	0.091	244.7	0.0275
333.73	0.091	244.7	0.0275
333.77	0.09	244.8	0.0275
333.80	0.092	244.8	0.0275
333.83	0.091	244.8	0.0275
333.87	0.092	244.8	0.0275
333.90	0.09	244.8	0.0275
333.93	0.09	244.8	0.0275
333.97	0.09	244.8	0.0266
334.00	0.089	244.8	0.0266
334.03	0.089	244.8	0.0266

Prova triassiale ciclica SNME01-C3			
pressione di confinamento (kPa)		380	
deviatore ciclico (kPa)		80	
frequenza (hz)		0.00071429	
tempo	cella di carico	u	LVDT
(min)	kN	(kPa)	δ (mm)
334.07	0.089	244.8	0.0266
334.10	0.087	244.7	0.0266
334.15	0.087	244.7	0.0266
334.18	0.087	244.8	0.0266
334.20	0.087	244.8	0.0266
334.23	0.086	244.8	0.0257
334.27	0.086	244.7	0.0257
334.30	0.086	244.7	0.0257
334.33	0.085	244.7	0.0257
334.37	0.085	244.7	0.0257
334.40	0.085	244.7	0.0249
334.43	0.084	244.7	0.0249
334.47	0.083	244.7	0.0249
334.50	0.083	244.7	0.0249
334.53	0.084	244.7	0.0249
334.57	0.083	244.7	0.0249
334.60	0.079	244.6	0.024
334.63	0.081	244.6	0.024
334.67	0.082	244.6	0.024
334.70	0.081	244.6	0.024
334.73	0.081	244.6	0.024
334.77	0.081	244.6	0.024
334.80	0.082	244.7	0.024
334.83	0.077	244.5	0.0231
334.87	0.078	244.5	0.0231
334.90	0.078	244.5	0.0231
334.93	0.078	244.5	0.0222
334.97	0.078	244.5	0.0222
335.00	0.079	244.5	0.0222
335.03	0.076	244.5	0.0222
335.07	0.076	244.5	0.0213
335.10	0.076	244.4	0.0213
335.13	0.075	244.4	0.0213
335.17	0.073	244.4	0.0204
335.20	0.073	244.4	0.0204
335.23	0.073	244.4	0.0204
335.27	0.073	244.3	0.0195
335.30	0.072	244.3	0.0195
335.33	0.071	244.3	0.0186
335.37	0.068	244.1	0.0186
335.40	0.069	244.1	0.0178
335.43	0.069	244.1	0.0178
335.47	0.071	244.2	0.0186
335.50	0.069	244.2	0.0178
335.53	0.069	244.1	0.0169
335.58	0.068	244.1	0.0169
335.62	0.067	244.1	0.016
335.63	0.066	244	0.016
335.67	0.066	244	0.0151
335.70	0.065	244	0.0151
335.73	0.064	244	0.0151
335.77	0.064	243.9	0.0142
335.80	0.064	243.9	0.0142
335.83	0.063	243.9	0.0133
335.87	0.061	243.8	0.0124
335.90	0.058	243.7	0.0115
335.93	0.06	243.7	0.0115
335.97	0.061	243.7	0.0115

Prova triassiale ciclica SNME01-C3			
ensione di confinamento (kPa)		380	
deviatore ciclico (kPa)		80	
frequenza (hz)		0.00071429	
tempo	cella di carico	u	LVDT
(min)	kN	(kPa)	δ (mm)
336.00	0.061	243.7	0.0115
336.03	0.061	243.7	0.0115
336.07	0.058	243.6	0.0107
336.10	0.058	243.6	0.0098
336.13	0.057	243.5	0.0089
336.17	0.055	243.5	0.0089
336.20	0.055	243.5	0.008
336.23	0.055	243.4	0.008
336.27	0.052	243.3	0.0062
336.30	0.053	243.3	0.0062
336.33	0.053	243.3	0.0053
336.37	0.054	243.4	0.0053
336.40	0.051	243.2	0.0053
336.43	0.051	243.2	0.0044
336.47	0.051	243.2	0.0036
336.50	0.049	243.1	0.0027
336.53	0.048	243.1	0.0018
336.57	0.048	243	0.0018
336.60	0.047	243	0.0009
336.63	0.045	242.9	0.0009
336.67	0.046	242.9	-0.0009
336.70	0.046	242.9	-0.0009
336.73	0.045	242.8	-0.0018
336.77	0.041	242.7	-0.0044
336.80	0.044	242.8	-0.0036
336.83	0.042	242.7	-0.0044
336.87	0.041	242.6	-0.0044
336.90	0.04	242.6	-0.0053
336.93	0.04	242.5	-0.0062
336.97	0.038	242.5	-0.0071
337.00	0.038	242.4	-0.0089
337.05	0.038	242.4	-0.0089
337.08	0.038	242.3	-0.0098
337.10	0.032	242.1	-0.0115
337.13	0.035	242.2	-0.0115
337.17	0.036	242.2	-0.0124
337.20	0.031	242	-0.0124
337.23	0.032	242	-0.0142
337.27	0.032	242	-0.0151
337.30	0.033	242	-0.0151
337.33	0.031	241.9	-0.016
337.37	0.029	241.8	-0.0178
337.40	0.025	241.6	-0.0195
337.43	0.029	241.7	-0.0195
337.47	0.028	241.7	-0.0195
337.50	0.028	241.7	-0.0204
337.53	0.027	241.6	-0.0213
337.57	0.024	241.4	-0.0231
337.60	0.025	241.4	-0.024
337.63	0.021	241.2	-0.0266
337.67	0.021	241.2	-0.0266
337.70	0.021	241.2	-0.0275
337.73	0.021	241.1	-0.0275
337.77	0.023	241.2	-0.0275
337.80	0.019	241	-0.0293
337.83	0.018	241	-0.0311
337.87	0.017	240.8	-0.0328
337.90	0.016	240.8	-0.0328

Prova triassiale ciclica SNME01-C3			
pressione di confinamento (kPa)		380	
deviatore ciclico (kPa)		80	
frequenza (hz)		0.00071429	
tempo	cella di carico	u	LVDT
(min)	kN	(kPa)	δ (mm)
337.93	0.018	240.8	-0.0328
337.97	0.018	240.8	-0.0337
338.00	0.016	240.7	-0.0355
338.03	0.013	240.5	-0.0373
338.07	0.012	240.4	-0.0382
338.10	0.011	240.4	-0.0391
338.13	0.01	240.3	-0.0391
338.17	0.01	240.3	-0.0408
338.20	0.01	240.2	-0.0417
338.23	0.01	240.2	-0.0426
338.27	0.008	240.1	-0.0435
338.30	0.007	240	-0.0453
338.33	0.007	240	-0.0462
338.37	0.005	239.9	-0.0462
338.40	0.004	239.9	-0.047
338.43	0.004	239.8	-0.0488
338.47	0.004	239.7	-0.0497
338.52	0.002	239.6	-0.0506
338.55	0.002	239.6	-0.0515
338.57	0.001	239.5	-0.0533
338.60	-0.001	239.4	-0.055
338.63	-0.001	239.3	-0.0559
338.67	-0.002	239.2	-0.0586
338.70	-0.003	239.1	-0.0586
338.73	-0.004	239.1	-0.0604
338.77	-0.004	239.1	-0.0621
338.80	-0.004	239	-0.0639
338.83	-0.006	238.9	-0.0657
338.87	-0.006	238.8	-0.0675
338.90	-0.006	238.7	-0.0692
338.93	-0.009	238.6	-0.0692
338.97	-0.01	238.6	-0.0728
339.00	-0.01	238.5	-0.0754
339.03	-0.01	238.4	-0.0772
339.07	-0.011	238.3	-0.0808
339.10	-0.012	238.2	-0.0834
339.13	-0.013	238	-0.0879
339.17	-0.014	237.9	-0.0879
339.20	-0.015	237.9	-0.0914
339.23	-0.015	237.8	-0.0959
339.27	-0.016	237.7	-0.1012
339.30	-0.017	237.5	-0.1074
339.33	-0.017	237.5	-0.1136
339.37	-0.018	237.3	-0.1243
339.40	-0.019	237.1	-0.1243
339.43	-0.02	237.1	-0.1367
339.47	-0.02	236.9	-0.1518
339.50	-0.021	236.7	-0.1669
339.53	-0.022	236.5	-0.1766
339.57	-0.023	236.4	-0.1846
339.60	-0.024	236.2	-0.1908
339.63	-0.025	236	-0.1908
339.67	-0.026	236	-0.1962
339.70	-0.026	235.9	-0.2006
339.73	-0.026	235.8	-0.2042
339.77	-0.028	235.6	-0.2068
339.80	-0.028	235.5	-0.2104
339.83	-0.029	235.4	-0.2139

Prova triassiale ciclica SNME01-C3			
ensione di confinamento (kPa)		380	
deviatore ciclico (kPa)		80	
frequenza (hz)		0.00071429	
tempo	cella di carico	u	LVDT
(min)	kN	(kPa)	δ (mm)
339.87	-0.03	235.3	-0.2139
339.90	-0.031	235.3	-0.2175
339.95	-0.032	235	-0.2228
339.98	-0.033	234.9	-0.2228
340.00	-0.033	234.9	-0.2255
340.03	-0.033	234.8	-0.2272
340.07	-0.034	234.7	-0.2308
340.10	-0.035	234.5	-0.2326
340.13	-0.036	234.4	-0.2361
340.17	-0.036	234.3	-0.2379
340.20	-0.037	234.2	-0.2379
340.23	-0.039	234.2	-0.2397
340.27	-0.039	234.1	-0.2414
340.30	-0.039	234	-0.2441
340.33	-0.04	233.8	-0.2468
340.37	-0.04	233.7	-0.2494
340.40	-0.042	233.6	-0.2521
340.43	-0.042	233.5	-0.2521
340.47	-0.043	233.5	-0.2539
340.50	-0.043	233.4	-0.2556
340.53	-0.043	233.3	-0.2583
340.57	-0.045	233	-0.2601
340.60	-0.045	233	-0.2619
340.63	-0.046	232.9	-0.2636
340.67	-0.047	232.7	-0.2636
340.70	-0.048	232.7	-0.2663
340.73	-0.048	232.6	-0.2681
340.77	-0.048	232.5	-0.2698
340.80	-0.049	232.4	-0.2716
340.83	-0.05	232.3	-0.2725
340.87	-0.051	232.2	-0.2752
340.90	-0.051	232.1	-0.2752
340.93	-0.053	232.1	-0.2769
340.97	-0.053	232	-0.2778
341.00	-0.053	231.9	-0.2787
341.03	-0.053	231.8	-0.2805
341.07	-0.054	231.7	-0.2823
341.10	-0.055	231.6	-0.284
341.13	-0.056	231.4	-0.284
341.17	-0.057	231.4	-0.2867
341.20	-0.057	231.3	-0.2876
341.23	-0.057	231.3	-0.2885
341.27	-0.057	231.2	-0.2903
341.30	-0.058	231	-0.292
341.33	-0.059	231	-0.2929
341.37	-0.059	230.8	-0.2929
341.42	-0.06	230.7	-0.2965
341.45	-0.061	230.7	-0.2974
341.47	-0.062	230.5	-0.2974
341.50	-0.061	230.5	-0.2982
341.53	-0.061	230.5	-0.3
341.57	-0.062	230.4	-0.3009
341.60	-0.063	230.3	-0.3027
341.63	-0.064	230.2	-0.3036
341.67	-0.064	230.1	-0.3053
341.70	-0.065	230	-0.3053
341.73	-0.065	230	-0.3053
341.77	-0.065	229.9	-0.3071

Prova triassiale ciclica SNME01-C3			
ensione di confinamento (kPa)		380	
deviatore ciclico (kPa)		80	
frequenza (hz)		0.00071429	
tempo	cella di carico	u	LVDT
(min)	kN	(kPa)	δ (mm)
341.80	-0.066	229.8	-0.308
341.83	-0.067	229.6	-0.3098
341.87	-0.067	229.6	-0.3107
341.90	-0.068	229.5	-0.3116
341.93	-0.069	229.4	-0.3116
341.97	-0.069	229.4	-0.3124
342.00	-0.069	229.3	-0.3133
342.03	-0.069	229.2	-0.3142
342.07	-0.069	229.1	-0.3151
342.10	-0.071	229	-0.3169
342.13	-0.071	229	-0.3169
342.17	-0.071	228.9	-0.3169
342.20	-0.072	228.9	-0.3178
342.23	-0.072	228.8	-0.3187
342.27	-0.072	228.7	-0.3196
342.30	-0.073	228.6	-0.3204
342.33	-0.073	228.6	-0.3213
342.37	-0.073	228.5	-0.3222
342.40	-0.074	228.4	-0.3222
342.43	-0.075	228.4	-0.3231
342.47	-0.075	228.3	-0.324
342.50	-0.075	228.2	-0.3249
342.53	-0.076	228.1	-0.3258
342.57	-0.076	228.1	-0.3258
342.60	-0.076	228	-0.3267
342.63	-0.077	228	-0.3267
342.67	-0.077	228	-0.3275
342.70	-0.077	227.9	-0.3275
342.73	-0.077	227.8	-0.3284
342.77	-0.078	227.7	-0.3293
342.80	-0.078	227.7	-0.3293
342.85	-0.078	227.7	-0.3302
342.88	-0.078	227.6	-0.3311
342.90	-0.078	227.5	-0.332
342.93	-0.079	227.4	-0.332
342.97	-0.079	227.4	-0.332
343.00	-0.08	227.4	-0.3329
343.03	-0.08	227.3	-0.3329
343.07	-0.08	227.3	-0.3338
343.10	-0.081	227.2	-0.3346
343.13	-0.081	227.1	-0.3346
343.17	-0.081	227.1	-0.3355
343.20	-0.081	227.1	-0.3355
343.23	-0.082	227.1	-0.3355
343.27	-0.082	227	-0.3364
343.30	-0.081	227	-0.3364
343.33	-0.082	226.9	-0.3364
343.37	-0.082	226.8	-0.3373
343.40	-0.081	226.8	-0.3373
343.43	-0.082	226.8	-0.3373
343.47	-0.083	226.8	-0.3382
343.50	-0.083	226.7	-0.3391
343.53	-0.083	226.7	-0.3391
343.57	-0.083	226.6	-0.3391
343.60	-0.083	226.6	-0.34
343.63	-0.083	226.5	-0.34
343.67	-0.083	226.5	-0.34
343.70	-0.084	226.5	-0.34

Prova triassiale ciclica SNME01-C3			
pressione di confinamento (kPa)		380	
deviatore ciclico (kPa)		80	
frequenza (hz)		0.00071429	
tempo	cella di carico	u	LVDT
(min)	kN	(kPa)	δ (mm)
343.73	-0.084	226.5	-0.3409
343.77	-0.084	226.4	-0.3409
343.80	-0.083	226.4	-0.3409
343.83	-0.083	226.4	-0.3409
343.87	-0.084	226.3	-0.3417
343.90	-0.084	226.3	-0.3417
343.93	-0.084	226.2	-0.3417
343.97	-0.084	226.2	-0.3417
344.00	-0.084	226.2	-0.3426
344.03	-0.084	226.2	-0.3426
344.07	-0.084	226.2	-0.3426
344.10	-0.085	226.1	-0.3426
344.13	-0.084	226.1	-0.3426
344.17	-0.084	226.1	-0.3426
344.20	-0.084	226.1	-0.3435
344.23	-0.084	226	-0.3435
344.27	-0.084	226	-0.3435
344.32	-0.084	226	-0.3435
344.35	-0.085	225.9	-0.3435
344.37	-0.084	226	-0.3435
344.40	-0.084	226	-0.3435
344.43	-0.084	225.9	-0.3435
344.47	-0.084	225.9	-0.3435
344.50	-0.084	225.9	-0.3444
344.53	-0.084	225.9	-0.3444
344.57	-0.084	225.9	-0.3444
344.60	-0.084	225.8	-0.3444
344.63	-0.084	225.8	-0.3444
344.67	-0.084	225.8	-0.3444
344.70	-0.083	225.8	-0.3444
344.73	-0.083	225.8	-0.3444
344.77	-0.083	225.8	-0.3444
344.80	-0.083	225.8	-0.3444
344.83	-0.083	225.8	-0.3444
344.87	-0.083	225.8	-0.3444
344.90	-0.083	225.8	-0.3444
344.93	-0.082	225.8	-0.3444
344.97	-0.082	225.8	-0.3444
345.00	-0.082	225.8	-0.3444
345.03	-0.082	225.8	-0.3444
345.07	-0.082	225.7	-0.3444
345.10	-0.082	225.7	-0.3444
345.13	-0.081	225.8	-0.3444
345.17	-0.081	225.7	-0.3444
345.20	-0.081	225.7	-0.3444
345.23	-0.081	225.7	-0.3444
345.27	-0.08	225.8	-0.3435
345.30	-0.08	225.8	-0.3435
345.33	-0.08	225.8	-0.3435
345.37	-0.08	225.8	-0.3435
345.40	-0.079	225.8	-0.3435
345.43	-0.079	225.8	-0.3435
345.47	-0.079	225.8	-0.3435
345.50	-0.079	225.8	-0.3435
345.53	-0.078	225.8	-0.3426
345.57	-0.078	225.8	-0.3426
345.60	-0.078	225.8	-0.3426
345.63	-0.078	225.8	-0.3426

Prova triassiale ciclica SNME01-C3			
pressione di confinamento (kPa)		380	
deviatore ciclico (kPa)		80	
frequenza (hz)		0.00071429	
tempo	cella di carico	u	LVDT
(min)	kN	(kPa)	δ (mm)
345.67	-0.077	225.8	-0.3426
345.70	-0.077	225.8	-0.3426
345.75	-0.076	225.9	-0.3417
345.78	-0.076	225.9	-0.3417
345.80	-0.076	225.9	-0.3417
345.83	-0.076	225.9	-0.3417
345.87	-0.075	225.9	-0.3417
345.90	-0.075	225.9	-0.3409
345.93	-0.075	225.9	-0.3409
345.97	-0.074	226	-0.3409
346.00	-0.073	226	-0.3409
346.03	-0.073	226	-0.3409
346.07	-0.073	226	-0.34
346.10	-0.073	226	-0.34
346.13	-0.072	226	-0.34
346.17	-0.072	226.1	-0.3391
346.20	-0.071	226.1	-0.3391
346.23	-0.071	226.1	-0.3391
346.27	-0.071	226.1	-0.3391
346.30	-0.07	226.2	-0.3382
346.33	-0.07	226.2	-0.3382
346.37	-0.069	226.2	-0.3382
346.40	-0.069	226.2	-0.3373
346.43	-0.068	226.3	-0.3373
346.47	-0.068	226.3	-0.3373
346.50	-0.068	226.3	-0.3364
346.53	-0.068	226.3	-0.3364
346.57	-0.067	226.4	-0.3355
346.60	-0.066	226.4	-0.3355
346.63	-0.065	226.5	-0.3346
346.67	-0.065	226.5	-0.3346
346.70	-0.064	226.5	-0.3346
346.73	-0.064	226.5	-0.3338
346.77	-0.064	226.6	-0.3338
346.80	-0.063	226.6	-0.3329
346.83	-0.063	226.7	-0.3329
346.87	-0.062	226.7	-0.332
346.90	-0.061	226.8	-0.332
346.93	-0.061	226.8	-0.3311
346.97	-0.061	226.8	-0.3311
347.00	-0.06	226.8	-0.3302
347.03	-0.059	226.9	-0.3293
347.07	-0.059	226.9	-0.3293
347.10	-0.058	227	-0.3284
347.13	-0.057	227.1	-0.3284
347.17	-0.057	227.1	-0.3284
347.22	-0.056	227.2	-0.3267
347.25	-0.056	227.2	-0.3267
347.27	-0.055	227.2	-0.3267
347.30	-0.055	227.2	-0.3258
347.33	-0.054	227.3	-0.3249
347.37	-0.053	227.4	-0.324
347.40	-0.053	227.4	-0.324
347.43	-0.053	227.5	-0.3231
347.47	-0.051	227.5	-0.3231
347.50	-0.05	227.6	-0.3222
347.53	-0.05	227.6	-0.3213
347.57	-0.051	227.6	-0.3213

Prova triassiale ciclica SNME01-C3			
pressione di confinamento (kPa)		380	
deviatore ciclico (kPa)		80	
frequenza (hz)		0.00071429	
tempo	cella di carico	u	LVDT
(min)	kN	(kPa)	δ (mm)
347.60	-0.05	227.8	-0.3204
347.63	-0.048	227.8	-0.3187
347.67	-0.048	227.8	-0.3187
347.70	-0.047	227.9	-0.3187
347.73	-0.046	228	-0.3178
347.77	-0.046	228	-0.3169
347.80	-0.046	228	-0.316
347.83	-0.045	228.1	-0.3142
347.87	-0.043	228.2	-0.3133
347.90	-0.043	228.3	-0.3124
347.93	-0.042	228.4	-0.3124
347.97	-0.041	228.5	-0.3116
348.00	-0.041	228.5	-0.3107
348.03	-0.041	228.5	-0.3098
348.07	-0.04	228.6	-0.3089
348.10	-0.039	228.6	-0.3071
348.13	-0.039	228.7	-0.3062
348.17	-0.037	228.8	-0.3062
348.20	-0.037	228.9	-0.3045
348.23	-0.037	228.9	-0.3036
348.27	-0.036	229	-0.3018
348.30	-0.035	229.1	-0.3009
348.33	-0.034	229.2	-0.2991
348.37	-0.033	229.3	-0.2982
348.40	-0.032	229.4	-0.2982
348.43	-0.031	229.4	-0.2965
348.47	-0.031	229.4	-0.2956
348.50	-0.031	229.5	-0.2938
348.53	-0.03	229.7	-0.292
348.57	-0.028	229.7	-0.2911
348.60	-0.029	229.8	-0.2894
348.63	-0.027	230	-0.2894
348.68	-0.027	230	-0.2867
348.72	-0.027	230.1	-0.284
348.73	-0.024	230.2	-0.284
348.77	-0.024	230.3	-0.2814
348.80	-0.024	230.3	-0.2805
348.83	-0.024	230.4	-0.2787
348.87	-0.023	230.5	-0.2769
348.90	-0.02	230.6	-0.2743
348.93	-0.021	230.7	-0.2734
348.97	-0.02	230.8	-0.2734
349.00	-0.018	230.9	-0.2716
349.03	-0.018	230.9	-0.269
349.07	-0.017	231	-0.2663
349.10	-0.017	231.1	-0.2645
349.13	-0.016	231.2	-0.2627
349.17	-0.015	231.3	-0.2601
349.20	-0.014	231.4	-0.2601
349.23	-0.013	231.6	-0.2565
349.27	-0.013	231.6	-0.2548
349.30	-0.013	231.6	-0.253
349.33	-0.012	231.8	-0.2494
349.37	-0.01	231.9	-0.2468
349.40	-0.01	232	-0.2432
349.43	-0.008	232.1	-0.2432
349.47	-0.007	232.3	-0.2397
349.50	-0.007	232.3	-0.237

Prova triassiale ciclica SNME01-C3			
pressione di confinamento (kPa)		380	
deviatore ciclico (kPa)		80	
frequenza (hz)		0.00071429	
tempo	cella di carico	u	LVDT
(min)	kN	(kPa)	δ (mm)
349.53	-0.007	232.3	-0.2343
349.57	-0.006	232.4	-0.2317
349.60	-0.005	232.6	-0.2281
349.63	-0.004	232.7	-0.2237
349.67	-0.003	232.8	-0.2237
349.70	-0.002	233	-0.2201
349.73	-0.002	233	-0.2157
349.77	-0.002	233	-0.2121
349.80	0	233.3	-0.2077
349.83	0.001	233.3	-0.2033
349.87	0.002	233.5	-0.1997
349.90	0.003	233.6	-0.1997
349.93	0.004	233.8	-0.1944
349.97	0.004	233.8	-0.19
350.00	0.005	233.8	-0.1864
350.03	0.005	234	-0.1829
350.07	0.007	234.1	-0.1784
350.12	0.007	234.2	-0.1749
350.15	0.007	234.2	-0.1713
350.17	0.009	234.4	-0.166
350.20	0.009	234.5	-0.1607
350.23	0.011	234.7	-0.1607
350.27	0.012	234.8	-0.1544
350.30	0.012	234.8	-0.1482
350.33	0.012	234.9	-0.1429
350.37	0.014	235	-0.1376
350.40	0.015	235.2	-0.1331
350.43	0.015	235.3	-0.1278
350.47	0.017	235.4	-0.1278
350.50	0.018	235.6	-0.1225
350.53	0.018	235.6	-0.1181
350.57	0.018	235.7	-0.1136
350.60	0.02	235.8	-0.1101
350.63	0.02	235.9	-0.1056
350.67	0.021	236	-0.1021
350.70	0.022	236.2	-0.1021
350.73	0.023	236.3	-0.0976
350.77	0.023	236.3	-0.0941
350.80	0.023	236.4	-0.0905
350.83	0.025	236.5	-0.0861
350.87	0.026	236.6	-0.0834
350.90	0.027	236.6	-0.0808
350.93	0.027	236.7	-0.0781
350.97	0.029	236.8	-0.0781
351.00	0.029	236.8	-0.0763
351.03	0.029	236.9	-0.0746
351.07	0.03	236.9	-0.0728
351.10	0.032	237	-0.071
351.13	0.032	237.1	-0.0701
351.17	0.033	237.2	-0.0701
351.20	0.034	237.3	-0.0683
351.23	0.034	237.3	-0.0666
351.27	0.034	237.3	-0.0657
351.30	0.036	237.4	-0.0639
351.33	0.036	237.5	-0.063
351.37	0.037	237.6	-0.0612
351.40	0.039	237.7	-0.0612
351.43	0.04	237.8	-0.0595

Prova triassiale ciclica SNME01-C3			
pressione di confinamento (kPa)		380	
deviatore ciclico (kPa)		80	
frequenza (hz)		0.00071429	
tempo	cella di carico	u	LVDT
(min)	kN	(kPa)	δ (mm)
351.47	0.04	237.8	-0.0586
351.50	0.04	237.8	-0.0559
351.53	0.041	237.9	-0.055
351.58	0.042	238	-0.0541
351.62	0.042	238.1	-0.0524
351.63	0.043	238.1	-0.0515
351.67	0.044	238.2	-0.0506
351.70	0.045	238.3	-0.0488
351.73	0.046	238.4	-0.0479
351.77	0.047	238.5	-0.0479
351.80	0.047	238.5	-0.047
351.83	0.047	238.6	-0.0453
351.87	0.048	238.7	-0.0444
351.90	0.049	238.7	-0.0435
351.93	0.05	238.8	-0.0417
351.97	0.052	238.9	-0.0399
352.00	0.052	239	-0.0399
352.03	0.052	239	-0.0391
352.07	0.052	239	-0.0382
352.10	0.053	239.1	-0.0373
352.13	0.054	239.2	-0.0364
352.17	0.055	239.3	-0.0346
352.20	0.056	239.4	-0.0337
352.23	0.057	239.5	-0.0337
352.27	0.057	239.5	-0.0328
352.30	0.056	239.5	-0.032
352.33	0.058	239.6	-0.0311
352.37	0.059	239.7	-0.0293
352.40	0.059	239.7	-0.0284
352.43	0.06	239.8	-0.0275
352.47	0.061	239.9	-0.0275
352.50	0.061	239.9	-0.0257
352.53	0.062	240	-0.0249
352.57	0.062	240.1	-0.024
352.60	0.064	240.2	-0.0222
352.63	0.063	240.2	-0.0222
352.67	0.064	240.3	-0.0213
352.70	0.066	240.4	-0.0213
352.73	0.066	240.4	-0.0195
352.77	0.065	240.4	-0.0195
352.80	0.066	240.5	-0.0186
352.83	0.068	240.6	-0.0169
352.87	0.068	240.7	-0.016
352.90	0.068	240.7	-0.0151
352.93	0.07	240.8	-0.0151
352.97	0.07	240.8	-0.0142
353.02	0.07	240.9	-0.0124
353.05	0.071	241	-0.0124
353.07	0.071	241	-0.0124
353.10	0.073	241.1	-0.0107
353.13	0.072	241.1	-0.0107
353.17	0.073	241.2	-0.0089
353.20	0.073	241.3	-0.0089
353.23	0.074	241.4	-0.008
353.27	0.075	241.4	-0.008
353.30	0.075	241.4	-0.0062
353.33	0.076	241.5	-0.0062
353.37	0.076	241.6	-0.0053

Prova triassiale ciclica SNME01-C3			
pressione di confinamento (kPa)		380	
deviatore ciclico (kPa)		80	
frequenza (hz)		0.00071429	
tempo	cella di carico	u	LVDT
(min)	kN	(kPa)	δ (mm)
353.40	0.077	241.7	-0.0036
353.43	0.077	241.7	-0.0036
353.47	0.079	241.8	-0.0027
353.50	0.078	241.9	-0.0027
353.53	0.078	241.9	-0.0018
353.57	0.079	242	-0.0009
353.60	0.079	242	0
353.63	0.081	242.1	0.0009
353.67	0.08	242.2	0.0009
353.70	0.081	242.2	0.0018
353.73	0.082	242.3	0.0018
353.77	0.082	242.3	0.0027
353.80	0.082	242.4	0.0036
353.83	0.082	242.4	0.0044
353.87	0.084	242.5	0.0053
353.90	0.084	242.5	0.0053
353.93	0.084	242.6	0.0062
353.97	0.084	242.7	0.0062
354.00	0.084	242.7	0.0071
354.03	0.085	242.7	0.0071
354.07	0.085	242.8	0.008
354.10	0.086	242.8	0.0089
354.13	0.087	242.9	0.0098
354.17	0.086	242.9	0.0098
354.20	0.087	243	0.0098
354.23	0.087	243	0.0107
354.27	0.088	243.1	0.0115
354.30	0.088	243.1	0.0115
354.33	0.088	243.2	0.0124
354.37	0.089	243.2	0.0133
354.40	0.089	243.3	0.0133
354.43	0.09	243.3	0.0133
354.48	0.09	243.4	0.0142
354.52	0.09	243.4	0.0151
354.53	0.093	243.6	0.0151
354.57	0.087	243.6	0.016
354.60	0.087	243.5	0.0151
354.63	0.091	243.6	0.0169
354.67	0.093	243.7	0.0178
354.70	0.092	243.7	0.0178
354.73	0.092	243.8	0.0178
354.77	0.092	243.8	0.0178
354.80	0.092	243.8	0.0178
354.83	0.092	243.8	0.0186
354.87	0.092	243.9	0.0186
354.90	0.093	243.9	0.0195
354.93	0.093	244	0.0195
354.97	0.093	244	0.0204
355.00	0.094	244.1	0.0204
355.03	0.094	244.1	0.0204
355.07	0.094	244.1	0.0204
355.10	0.094	244.3	0.0213
355.13	0.094	244.3	0.0213
355.17	0.094	244.3	0.0213
355.20	0.094	244.4	0.0222
355.23	0.095	244.4	0.0222
355.27	0.095	244.4	0.0222
355.30	0.095	244.5	0.0231

Prova triassiale ciclica SNME01-C3			
pressione di confinamento (kPa)		380	
deviatore ciclico (kPa)		80	
frequenza (hz)		0.00071429	
tempo	cella di carico	u	LVDT
(min)	kN	(kPa)	δ (mm)
355.33	0.095	244.5	0.0231
355.37	0.095	244.5	0.0231
355.40	0.095	244.6	0.0231
355.43	0.095	244.6	0.024
355.47	0.097	244.7	0.024
355.50	0.095	244.7	0.024
355.53	0.095	244.7	0.024
355.57	0.095	244.7	0.024
355.60	0.096	244.8	0.0249
355.63	0.096	244.8	0.0249
355.67	0.096	244.8	0.0249
355.70	0.096	244.8	0.0249
355.73	0.095	244.8	0.0249
355.77	0.095	244.9	0.0249
355.80	0.097	244.9	0.0257
355.83	0.096	244.9	0.0257
355.87	0.096	244.9	0.0257
355.90	0.096	245	0.0257
355.95	0.096	245	0.0257
355.97	0.096	245	0.0257
356.00	0.098	245.1	0.0266
356.03	0.097	245.1	0.0266
356.07	0.096	245.1	0.0266
356.10	0.096	245.1	0.0257
356.13	0.093	245	0.0257
356.17	0.095	245.1	0.0266
356.20	0.098	245.2	0.0266
356.23	0.096	245.2	0.0266
356.27	0.093	245.1	0.0266
356.30	0.094	245.1	0.0257
356.33	0.094	245.2	0.0266
356.37	0.095	245.2	0.0266
356.40	0.097	245.3	0.0275
356.43	0.095	245.3	0.0275
356.47	0.095	245.3	0.0275
356.50	0.095	245.3	0.0275
356.53	0.094	245.3	0.0275
356.57	0.094	245.3	0.0275
356.60	0.094	245.3	0.0275
356.63	0.094	245.3	0.0266
356.67	0.094	245.4	0.0266
356.70	0.094	245.4	0.0266
356.73	0.093	245.4	0.0266
356.77	0.093	245.4	0.0266
356.80	0.093	245.4	0.0266
356.83	0.093	245.4	0.0266
356.87	0.093	245.4	0.0266
356.90	0.092	245.4	0.0266
356.93	0.089	245.3	0.0257
356.97	0.091	245.4	0.0257
357.00	0.091	245.4	0.0266
357.03	0.091	245.4	0.0266
357.07	0.094	245.5	0.0275
357.10	0.092	245.5	0.0266
357.13	0.09	245.4	0.0257
357.17	0.091	245.5	0.0266
357.20	0.091	245.5	0.0266
357.23	0.091	245.5	0.0266

Prova triassiale ciclica SNME01-C3			
pressione di confinamento (kPa)		380	
deviatore ciclico (kPa)		80	
frequenza (hz)		0.00071429	
tempo	cella di carico	u	LVDT
(min)	kN	(kPa)	δ (mm)
357.27	0.091	245.5	0.0266
357.30	0.09	245.5	0.0257
357.33	0.089	245.4	0.0257
357.38	0.089	245.4	0.0257
357.42	0.089	245.4	0.0257
357.43	0.088	245.4	0.0257
357.47	0.088	245.4	0.0257
357.50	0.087	245.4	0.0257
357.53	0.087	245.4	0.0257
357.57	0.087	245.4	0.0249
357.60	0.087	245.4	0.0249
357.63	0.086	245.4	0.0249
357.67	0.085	245.4	0.0249
357.70	0.085	245.4	0.0249
357.73	0.085	245.4	0.0249
357.77	0.084	245.4	0.0249
357.80	0.084	245.4	0.024
357.83	0.084	245.4	0.024
357.87	0.083	245.3	0.024
357.90	0.082	245.3	0.024
357.93	0.082	245.3	0.024
357.97	0.082	245.3	0.0231
358.00	0.081	245.3	0.0231
358.03	0.08	245.3	0.0231
358.07	0.08	245.3	0.0231
358.10	0.081	245.3	0.0231
358.13	0.08	245.2	0.0222
358.17	0.079	245.2	0.0222
358.20	0.079	245.2	0.0222
358.23	0.077	245.2	0.0222
358.27	0.078	245.2	0.0213
358.30	0.078	245.2	0.0213
358.33	0.076	245.1	0.0213
358.37	0.076	245.1	0.0213
358.40	0.076	245.1	0.0195
358.43	0.073	245	0.0195
358.47	0.075	244.9	0.0195
358.50	0.072	244.9	0.0195
358.53	0.072	244.9	0.0186
358.57	0.075	245	0.0195
358.60	0.074	245	0.0195
358.63	0.072	244.9	0.0186
358.67	0.071	244.9	0.0178
358.70	0.07	244.9	0.0178
358.73	0.071	244.9	0.0178
358.77	0.071	244.9	0.0178
358.80	0.067	244.7	0.016
358.85	0.07	244.8	0.0169
358.88	0.07	244.8	0.016
358.90	0.068	244.7	0.0151
358.93	0.066	244.7	0.0151
358.97	0.066	244.7	0.0151
359.00	0.066	244.6	0.0142
359.03	0.064	244.6	0.0142
359.07	0.064	244.6	0.0142
359.10	0.064	244.6	0.0133
359.13	0.063	244.5	0.0133
359.17	0.062	244.5	0.0124

Prova triassiale ciclica SNME01-C3			
pressione di confinamento (kPa)		380	
deviatore ciclico (kPa)		80	
frequenza (hz)		0.00071429	
tempo	cella di carico	u	LVDT
(min)	kN	(kPa)	δ (mm)
359.20	0.06	244.4	0.0115
359.23	0.061	244.4	0.0115
359.27	0.062	244.4	0.0115
359.30	0.062	244.4	0.0115
359.33	0.062	244.4	0.0107
359.37	0.058	244.2	0.0089
359.40	0.057	244.2	0.008
359.43	0.057	244.2	0.008
359.47	0.058	244.2	0.008
359.50	0.057	244.2	0.008
359.53	0.056	244.2	0.008
359.57	0.056	244.1	0.0071
359.60	0.052	244	0.0053
359.63	0.052	243.9	0.0044
359.67	0.053	243.9	0.0044
359.70	0.052	243.9	0.0036
359.73	0.05	243.8	0.0036
359.77	0.052	243.8	0.0027
359.80	0.052	243.9	0.0018
359.83	0.05	243.8	0.0018
359.87	0.047	243.7	0.0009
359.90	0.049	243.7	0.0009
359.93	0.047	243.6	-0.0009
359.97	0.046	243.5	-0.0009
360.00	0.042	243.5	-0.0018
360.03	0.042	243.4	-0.0027
360.07	0.044	243.4	-0.0027
360.10	0.044	243.4	-0.0036
360.13	0.046	243.4	-0.0036
360.17	0.042	243.3	-0.0053
360.20	0.04	243.2	-0.0053
360.23	0.04	243.2	-0.0062
360.28	0.04	243.1	-0.0089
360.32	0.038	243	-0.0089
360.33	0.037	243	-0.0089
360.37	0.037	243	-0.0098
360.40	0.037	242.9	-0.0107
360.43	0.035	242.8	-0.0124
360.47	0.033	242.7	-0.0133
360.50	0.034	242.7	-0.0133
360.53	0.033	242.7	-0.0133
360.57	0.036	242.7	-0.0133
360.60	0.036	242.8	-0.0142
360.63	0.031	242.5	-0.0169
360.67	0.03	242.5	-0.0169
360.70	0.029	242.4	-0.0186
360.73	0.029	242.4	-0.0186
360.77	0.028	242.3	-0.0186
360.80	0.027	242.3	-0.0195
360.83	0.027	242.3	-0.0213
360.87	0.026	242.2	-0.0222
360.90	0.022	241.9	-0.0249
360.93	0.024	242	-0.0249
360.97	0.024	241.9	-0.0266
361.00	0.022	241.8	-0.0266
361.03	0.021	241.8	-0.0275
361.07	0.021	241.8	-0.0284
361.10	0.02	241.7	-0.0293

Prova triassiale ciclica SNME01-C3			
pressione di confinamento (kPa)		380	
deviatore ciclico (kPa)		80	
frequenza (hz)		0.00071429	
tempo	cella di carico	u	LVDT
(min)	kN	(kPa)	δ (mm)
361.13	0.019	241.6	-0.0302
361.17	0.019	241.6	-0.0311
361.20	0.018	241.5	-0.0328
361.23	0.019	241.5	-0.0328
361.27	0.016	241.5	-0.0328
361.30	0.016	241.4	-0.0346
361.33	0.015	241.2	-0.0364
361.37	0.013	241.1	-0.0373
361.40	0.013	241.1	-0.0382
361.43	0.013	241	-0.0391
361.47	0.011	240.9	-0.0391
361.50	0.01	240.9	-0.0408
361.53	0.01	240.8	-0.0417
361.57	0.009	240.7	-0.0435
361.60	0.008	240.7	-0.0444
361.63	0.007	240.6	-0.0462
361.67	0.006	240.5	-0.047
361.70	0.006	240.5	-0.047
361.75	0.004	240.4	-0.0488
361.78	0.005	240.3	-0.0497
361.80	0.001	240.2	-0.0497
361.83	0.003	240.2	-0.0515
361.87	0.003	240.2	-0.0524
361.90	0.003	240	-0.0541
361.93	-0.001	239.9	-0.0568
361.97	-0.001	239.9	-0.0595
362.00	-0.002	239.8	-0.0612
362.03	-0.003	239.7	-0.0612
362.07	-0.004	239.7	-0.063
362.10	-0.004	239.6	-0.0648
362.13	-0.005	239.5	-0.0666
362.17	-0.008	239.3	-0.0701
362.20	-0.007	239.3	-0.071
362.23	-0.007	239.2	-0.0737
362.27	-0.009	239.1	-0.0737
362.30	-0.007	239.1	-0.0754
362.33	-0.007	239.2	-0.0772
362.37	-0.01	238.9	-0.0808
362.40	-0.012	238.8	-0.0843
362.43	-0.012	238.7	-0.087
362.47	-0.013	238.6	-0.0905
362.50	-0.014	238.5	-0.0905
362.53	-0.014	238.5	-0.095
362.57	-0.014	238.4	-0.0994
362.60	-0.015	238.3	-0.1047
362.63	-0.019	237.9	-0.1154
362.67	-0.019	237.9	-0.1225
362.70	-0.018	237.8	-0.1296
362.73	-0.019	237.6	-0.1296
362.77	-0.019	237.6	-0.1394
362.80	-0.019	237.5	-0.1509
362.83	-0.019	237.4	-0.1633
362.87	-0.023	237	-0.1775
362.90	-0.023	236.9	-0.1846
362.93	-0.024	236.7	-0.1917
362.97	-0.025	236.6	-0.1917
363.00	-0.026	236.6	-0.1997
363.03	-0.026	236.4	-0.2015

Prova triassiale ciclica SNME01-C3			
pressione di confinamento (kPa)		380	
deviatore ciclico (kPa)		80	
frequenza (hz)		0.00071429	
tempo	cella di carico	u	LVDT
(min)	kN	(kPa)	δ (mm)
363.07	-0.026	236.3	-0.2059
363.10	-0.028	236.1	-0.2104
363.13	-0.028	236	-0.213
363.18	-0.029	235.9	-0.2166
363.22	-0.03	235.8	-0.2192
363.23	-0.031	235.6	-0.2228
363.27	-0.032	235.5	-0.2246
363.30	-0.032	235.5	-0.2246
363.33	-0.033	235.5	-0.2263
363.37	-0.033	235.3	-0.229
363.40	-0.034	235.2	-0.2317
363.43	-0.035	235	-0.2352
363.47	-0.036	234.9	-0.2379
363.50	-0.036	234.8	-0.2388
363.53	-0.038	234.7	-0.2388
363.57	-0.038	234.7	-0.2414
363.60	-0.038	234.6	-0.2441
363.63	-0.041	234.3	-0.2485
363.67	-0.039	234.3	-0.2485
363.70	-0.04	234.3	-0.2512
363.73	-0.041	234.1	-0.2539
363.77	-0.043	233.9	-0.2539
363.80	-0.045	233.9	-0.2565
363.83	-0.045	233.8	-0.2592
363.87	-0.044	233.7	-0.2601
363.90	-0.042	233.8	-0.2601
363.93	-0.046	233.5	-0.2636
363.97	-0.046	233.4	-0.2654
364.00	-0.047	233.3	-0.2654
364.03	-0.05	233.3	-0.2672
364.07	-0.05	233	-0.2707
364.10	-0.048	233	-0.2716
364.13	-0.049	233	-0.2725
364.17	-0.05	232.8	-0.2743
364.20	-0.049	232.8	-0.2743
364.23	-0.05	232.7	-0.2743
364.27	-0.052	232.7	-0.2761
364.30	-0.052	232.5	-0.2787
364.33	-0.053	232.4	-0.2805
364.37	-0.053	232.3	-0.2832
364.40	-0.055	232.2	-0.284
364.43	-0.055	232.1	-0.2867
364.47	-0.056	232	-0.2867
364.50	-0.056	232	-0.2894
364.53	-0.056	231.8	-0.2903
364.57	-0.057	231.8	-0.2911
364.60	-0.058	231.6	-0.2929
364.65	-0.058	231.5	-0.2938
364.68	-0.06	231.4	-0.2956
364.70	-0.058	231.4	-0.2956
364.73	-0.059	231.3	-0.2974
364.77	-0.06	231.2	-0.2991
364.80	-0.062	231	-0.2991
364.83	-0.063	231	-0.3009
364.87	-0.063	230.9	-0.3018
364.90	-0.062	230.9	-0.3018
364.93	-0.063	230.8	-0.3036
364.97	-0.064	230.7	-0.3053

Prova triassiale ciclica SNME01-C3			
pressione di confinamento (kPa)		380	
deviatore ciclico (kPa)		80	
frequenza (hz)		0.00071429	
tempo	cella di carico	u	LVDT
(min)	kN	(kPa)	δ (mm)
365.00	-0.063	230.6	-0.3062
365.03	-0.065	230.5	-0.3062
365.07	-0.065	230.5	-0.3071
365.10	-0.065	230.4	-0.3089
365.13	-0.066	230.3	-0.3098
365.17	-0.067	230.2	-0.3116
365.20	-0.067	230.1	-0.3124
365.23	-0.068	230	-0.3133
365.27	-0.068	229.9	-0.3133
365.30	-0.069	229.9	-0.3151
365.33	-0.069	229.8	-0.3151
365.37	-0.069	229.7	-0.3169
365.40	-0.07	229.7	-0.3178
365.43	-0.071	229.5	-0.3187
365.47	-0.072	229.4	-0.3196
365.50	-0.072	229.4	-0.3196
365.53	-0.071	229.4	-0.3204
365.57	-0.071	229.3	-0.3213
365.60	-0.073	229.1	-0.3222
365.63	-0.073	229.1	-0.3231
365.67	-0.073	229.1	-0.324
365.70	-0.075	228.8	-0.3258
365.73	-0.075	228.8	-0.3258
365.77	-0.073	228.8	-0.3258
365.80	-0.073	228.8	-0.3258
365.83	-0.074	228.7	-0.3267
365.87	-0.076	228.6	-0.3284
365.90	-0.076	228.5	-0.3284
365.93	-0.077	228.4	-0.3302
365.97	-0.076	228.4	-0.3302
366.00	-0.077	228.4	-0.3302
366.03	-0.077	228.4	-0.3302
366.07	-0.077	228.2	-0.332
366.12	-0.079	228.1	-0.3329
366.15	-0.079	228.1	-0.3329
366.17	-0.078	228.1	-0.3329
366.20	-0.078	228	-0.3338
366.23	-0.079	228	-0.3338
366.27	-0.079	227.9	-0.3346
366.30	-0.079	227.8	-0.3346
366.33	-0.08	227.8	-0.3346
366.37	-0.08	227.8	-0.3355
366.40	-0.08	227.7	-0.3364
366.43	-0.081	227.7	-0.3364
366.47	-0.08	227.6	-0.3373
366.50	-0.081	227.6	-0.3373
366.53	-0.082	227.5	-0.3373
366.57	-0.081	227.5	-0.3382
366.60	-0.081	227.5	-0.3382
366.63	-0.081	227.4	-0.3382
366.67	-0.082	227.4	-0.3391
366.70	-0.082	227.3	-0.34
366.73	-0.082	227.3	-0.34
366.77	-0.082	227.2	-0.34
366.80	-0.083	227.2	-0.34
366.83	-0.083	227.1	-0.3409
366.87	-0.082	227.1	-0.3409
366.90	-0.083	227.1	-0.3409

Prova triassiale ciclica SNME01-C3			
ensione di confinamento (kPa)		380	
deviatore ciclico (kPa)		80	
frequenza (hz)		0.00071429	
tempo	cella di carico	u	LVDT
(min)	kN	(kPa)	δ (mm)
366.93	-0.083	227	-0.3417
366.97	-0.083	227	-0.3417
367.00	-0.084	226.9	-0.3417
367.03	-0.084	226.9	-0.3426
367.07	-0.084	226.9	-0.3426
367.10	-0.083	226.9	-0.3426
367.13	-0.084	226.8	-0.3426
367.17	-0.084	226.8	-0.3435
367.20	-0.084	226.8	-0.3435
367.23	-0.084	226.7	-0.3435
367.27	-0.084	226.7	-0.3435
367.30	-0.084	226.7	-0.3444
367.33	-0.084	226.7	-0.3444
367.37	-0.084	226.6	-0.3444
367.40	-0.084	226.6	-0.3444
367.43	-0.084	226.6	-0.3444
367.47	-0.084	226.6	-0.3444
367.50	-0.084	226.6	-0.3453
367.55	-0.084	226.5	-0.3453
367.58	-0.084	226.5	-0.3453
367.60	-0.084	226.5	-0.3453
367.63	-0.084	226.4	-0.3453
367.67	-0.084	226.4	-0.3453
367.70	-0.084	226.4	-0.3453
367.73	-0.084	226.4	-0.3453
367.77	-0.084	226.4	-0.3462
367.80	-0.084	226.4	-0.3462
367.83	-0.084	226.4	-0.3453
367.87	-0.084	226.3	-0.3462
367.90	-0.084	226.3	-0.3462
367.93	-0.084	226.3	-0.3462
367.97	-0.083	226.3	-0.3462
368.00	-0.084	226.3	-0.3462
368.03	-0.083	226.3	-0.3462
368.07	-0.083	226.3	-0.3462
368.10	-0.083	226.2	-0.3462
368.13	-0.083	226.2	-0.3462
368.17	-0.083	226.2	-0.3462
368.20	-0.083	226.2	-0.3462
368.23	-0.083	226.2	-0.3462
368.27	-0.082	226.2	-0.3462
368.30	-0.082	226.2	-0.3462
368.33	-0.082	226.2	-0.3462
368.37	-0.082	226.2	-0.3462
368.40	-0.082	226.2	-0.3462
368.43	-0.081	226.2	-0.3462
368.47	-0.081	226.2	-0.3462
368.50	-0.081	226.2	-0.3462
368.53	-0.081	226.2	-0.3462
368.57	-0.081	226.2	-0.3453
368.60	-0.081	226.2	-0.3453
368.63	-0.08	226.2	-0.3453
368.67	-0.08	226.2	-0.3453
368.70	-0.08	226.2	-0.3453
368.73	-0.08	226.2	-0.3453
368.77	-0.079	226.2	-0.3453
368.80	-0.079	226.2	-0.3453
368.83	-0.079	226.2	-0.3444

Prova triassiale ciclica SNME01-C3			
ensione di confinamento (kPa)		380	
deviatore ciclico (kPa)		80	
frequenza (hz)		0.00071429	
tempo	cella di carico	u	LVDT
(min)	kN	(kPa)	δ (mm)
368.87	-0.078	226.2	-0.3444
368.90	-0.078	226.3	-0.3444
368.93	-0.078	226.3	-0.3444
368.97	-0.077	226.3	-0.3444
369.02	-0.077	226.3	-0.3444
369.05	-0.077	226.3	-0.3435
369.07	-0.077	226.3	-0.3435
369.10	-0.076	226.3	-0.3435
369.13	-0.076	226.3	-0.3435
369.17	-0.076	226.3	-0.3435
369.20	-0.075	226.4	-0.3426
369.23	-0.075	226.4	-0.3426
369.27	-0.074	226.4	-0.3426
369.30	-0.074	226.4	-0.3426
369.33	-0.074	226.4	-0.3426
369.37	-0.074	226.4	-0.3417
369.40	-0.073	226.5	-0.3417
369.43	-0.073	226.5	-0.3417
369.47	-0.072	226.5	-0.3409
369.50	-0.072	226.5	-0.3409
369.53	-0.071	226.6	-0.3409
369.57	-0.071	226.6	-0.3409
369.60	-0.071	226.6	-0.34
369.63	-0.071	226.6	-0.34
369.67	-0.07	226.7	-0.3391
369.70	-0.069	226.7	-0.3391
369.73	-0.069	226.7	-0.3391
369.77	-0.068	226.8	-0.3391
369.80	-0.067	226.8	-0.3382
369.83	-0.067	226.8	-0.3382
369.87	-0.067	226.8	-0.3373
369.90	-0.066	226.9	-0.3373
369.93	-0.066	226.9	-0.3373
369.97	-0.066	226.9	-0.3364
370.00	-0.065	227	-0.3364
370.03	-0.064	227	-0.3364
370.07	-0.064	227	-0.3355
370.10	-0.064	227	-0.3346
370.13	-0.063	227.1	-0.3346
370.17	-0.062	227.1	-0.3338
370.20	-0.062	227.2	-0.3338
370.23	-0.061	227.2	-0.3338
370.27	-0.061	227.2	-0.3329
370.30	-0.061	227.3	-0.332
370.33	-0.06	227.3	-0.3311
370.37	-0.059	227.4	-0.3311
370.40	-0.059	227.4	-0.3302
370.45	-0.058	227.5	-0.3302
370.48	-0.057	227.5	-0.3293
370.50	-0.057	227.5	-0.3293
370.53	-0.057	227.6	-0.3284
370.57	-0.055	227.7	-0.3284
370.60	-0.055	227.7	-0.3275
370.63	-0.055	227.7	-0.3267
370.67	-0.054	227.8	-0.3258
370.70	-0.053	227.9	-0.3258
370.73	-0.053	227.9	-0.3249
370.77	-0.052	228	-0.324

Prova triassiale ciclica SNME01-C3			
pressione di confinamento (kPa)		380	
deviatore ciclico (kPa)		80	
frequenza (hz)		0.00071429	
tempo	cella di carico	u	LVDT
(min)	kN	(kPa)	δ (mm)
370.80	-0.052	228	-0.324
370.83	-0.05	228	-0.3231
370.87	-0.05	228.1	-0.3222
370.90	-0.05	228.1	-0.3222
370.93	-0.049	228.2	-0.3204
370.97	-0.048	228.3	-0.3204
371.00	-0.048	228.3	-0.3187
371.03	-0.046	228.4	-0.3187
371.07	-0.046	228.4	-0.3178
371.10	-0.046	228.5	-0.3178
371.13	-0.046	228.5	-0.316
371.17	-0.045	228.6	-0.3151
371.20	-0.043	228.7	-0.3142
371.23	-0.043	228.7	-0.3133
371.27	-0.043	228.8	-0.3133
371.30	-0.041	228.8	-0.3124
371.33	-0.041	229	-0.3116
371.37	-0.041	229	-0.3098
371.40	-0.04	229.1	-0.3089
371.43	-0.039	229.2	-0.308
371.47	-0.038	229.3	-0.3062
371.50	-0.037	229.4	-0.3062
371.53	-0.037	229.4	-0.3053
371.57	-0.037	229.4	-0.3045
371.60	-0.036	229.5	-0.3027
371.63	-0.035	229.6	-0.3018
371.67	-0.033	229.7	-0.3
371.70	-0.033	229.8	-0.2991
371.73	-0.032	229.9	-0.2991
371.77	-0.032	229.9	-0.2974
371.80	-0.032	229.9	-0.2965
371.83	-0.031	230	-0.2947
371.87	-0.03	230.2	-0.2929
371.92	-0.029	230.3	-0.2911
371.95	-0.029	230.3	-0.2903
371.97	-0.028	230.4	-0.2894
372.00	-0.026	230.5	-0.2867
372.03	-0.026	230.6	-0.2858
372.07	-0.025	230.7	-0.2858
372.10	-0.024	230.7	-0.2832
372.13	-0.024	230.8	-0.2814
372.17	-0.024	230.9	-0.2796
372.20	-0.022	231	-0.2778
372.23	-0.021	231.1	-0.2752
372.27	-0.02	231.2	-0.2734
372.30	-0.019	231.3	-0.2734
372.33	-0.019	231.3	-0.2716
372.37	-0.019	231.4	-0.2698
372.40	-0.018	231.5	-0.2672
372.43	-0.017	231.6	-0.2645
372.47	-0.016	231.7	-0.2627
372.50	-0.016	231.8	-0.2601
372.53	-0.014	231.9	-0.2601
372.57	-0.014	231.9	-0.2574
372.60	-0.014	232	-0.2548
372.63	-0.012	232.2	-0.2512
372.67	-0.01	232.3	-0.2485
372.70	-0.01	232.4	-0.2468

Prova triassiale ciclica SNME01-C3			
pressione di confinamento (kPa)		380	
deviatore ciclico (kPa)		80	
frequenza (hz)		0.00071429	
tempo	cella di carico	u	LVDT
(min)	kN	(kPa)	δ (mm)
372.73	-0.01	232.5	-0.2441
372.77	-0.008	232.6	-0.2441
372.80	-0.007	232.6	-0.2406
372.83	-0.007	232.7	-0.2379
372.87	-0.007	232.8	-0.2343
372.90	-0.006	233	-0.2308
372.93	-0.005	233.1	-0.2272
372.97	-0.003	233.2	-0.2228
373.00	-0.003	233.4	-0.2228
373.03	-0.002	233.4	-0.2201
373.07	-0.002	233.5	-0.2175
373.10	-0.002	233.5	-0.213
373.13	0	233.7	-0.2086
373.17	0	233.8	-0.205
373.20	0.002	234	-0.1988
373.23	0.003	234.1	-0.1988
373.27	0.003	234.1	-0.1953
373.30	0.003	234.2	-0.1908
373.33	0.005	234.4	-0.1846
373.38	0.006	234.5	-0.1793
373.40	0.006	234.6	-0.1758
373.43	0.006	234.6	-0.1731
373.47	0.009	234.8	-0.1695
373.50	0.009	234.9	-0.1669
373.53	0.009	235	-0.1633
373.57	0.011	235.2	-0.1633
373.60	0.011	235.2	-0.1571
373.63	0.011	235.2	-0.1518
373.67	0.013	235.4	-0.1456
373.70	0.014	235.6	-0.1402
373.73	0.014	235.6	-0.1358
373.77	0.015	235.8	-0.1314
373.80	0.017	236	-0.1314
373.83	0.018	236	-0.126
373.87	0.018	236	-0.1216
373.90	0.017	236.1	-0.1172
373.93	0.019	236.3	-0.1127
373.97	0.02	236.4	-0.1083
374.00	0.021	236.5	-0.1039
374.03	0.022	236.7	-0.1039
374.07	0.023	236.7	-0.0994
374.10	0.023	236.8	-0.095
374.13	0.024	236.9	-0.0914
374.17	0.025	237	-0.0879
374.20	0.026	237.1	-0.0843
374.23	0.026	237.2	-0.0817
374.27	0.028	237.3	-0.0817
374.30	0.029	237.3	-0.079
374.33	0.029	237.4	-0.0772
374.37	0.029	237.4	-0.0754
374.40	0.031	237.5	-0.0737
374.43	0.031	237.6	-0.0719
374.47	0.032	237.6	-0.0701
374.50	0.033	237.7	-0.0701
374.53	0.034	237.7	-0.0683
374.57	0.034	237.8	-0.0666
374.60	0.035	237.9	-0.0657
374.63	0.036	238	-0.0639

Prova triassiale ciclica SNME01-C3			
pressione di confinamento (kPa)		380	
deviatore ciclico (kPa)		80	
frequenza (hz)		0.00071429	
tempo	cella di carico	u	LVDT
(min)	kN	(kPa)	δ (mm)
374.67	0.037	238.1	-0.0621
374.70	0.037	238.1	-0.0612
374.73	0.039	238.2	-0.0612
374.77	0.039	238.2	-0.0604
374.82	0.038	238.3	-0.0586
374.85	0.043	238.5	-0.0586
374.87	0.042	238.5	-0.0541
374.90	0.042	238.5	-0.0541
374.93	0.041	238.6	-0.0533
374.97	0.043	238.7	-0.0515
375.00	0.045	238.8	-0.0506
375.03	0.045	238.8	-0.0497
375.07	0.046	238.9	-0.0497
375.10	0.047	238.9	-0.0488
375.13	0.047	239	-0.0479
375.17	0.047	239.1	-0.0462
375.20	0.049	239.2	-0.0453
375.23	0.049	239.2	-0.0444
375.27	0.05	239.3	-0.0426
375.30	0.051	239.4	-0.0426
375.33	0.052	239.4	-0.0417
375.37	0.052	239.5	-0.0399
375.40	0.055	239.6	-0.0382
375.43	0.054	239.7	-0.0373
375.47	0.054	239.7	-0.0364
375.50	0.054	239.8	-0.0346
375.53	0.056	239.9	-0.0346
375.57	0.055	239.9	-0.0337
375.60	0.055	239.9	-0.0337
375.63	0.056	240	-0.032
375.67	0.058	240.1	-0.0311
375.70	0.059	240.2	-0.0293
375.73	0.06	240.3	-0.0284
375.77	0.061	240.4	-0.0284
375.80	0.061	240.4	-0.0275
375.83	0.061	240.4	-0.0266
375.87	0.061	240.5	-0.0249
375.90	0.064	240.6	-0.024
375.93	0.063	240.7	-0.0231
375.97	0.064	240.7	-0.0222
376.00	0.065	240.8	-0.0222
376.03	0.066	240.8	-0.0213
376.07	0.066	240.9	-0.0204
376.10	0.065	241	-0.0195
376.13	0.067	241.1	-0.0178
376.17	0.067	241.1	-0.0178
376.20	0.068	241.2	-0.016
376.23	0.07	241.2	-0.016
376.28	0.068	241.3	-0.0151
376.32	0.068	241.4	-0.0133
376.33	0.072	241.6	-0.0133
376.37	0.072	241.6	-0.0124
376.40	0.072	241.6	-0.0115
376.43	0.071	241.7	-0.0107
376.47	0.072	241.7	-0.0098
376.50	0.073	241.8	-0.0089
376.53	0.076	241.9	-0.008
376.57	0.073	241.9	-0.008

Prova triassiale ciclica SNME01-C3			
pressione di confinamento (kPa)		380	
deviatore ciclico (kPa)		80	
frequenza (hz)		0.00071429	
tempo	cella di carico	u	LVDT
(min)	kN	(kPa)	δ (mm)
376.60	0.074	241.9	-0.008
376.63	0.074	242	-0.0071
376.67	0.075	242	-0.0062
376.70	0.076	242.1	-0.0044
376.73	0.078	242.3	-0.0036
376.77	0.077	242.3	-0.0036
376.80	0.078	242.3	-0.0036
376.83	0.078	242.3	-0.0027
376.87	0.078	242.4	-0.0018
376.90	0.08	242.5	-0.0009
376.93	0.08	242.6	0
376.97	0.08	242.6	0.0009
377.00	0.08	242.7	0.0018
377.03	0.081	242.8	0.0018
377.07	0.082	242.8	0.0018
377.10	0.082	242.8	0.0027
377.13	0.082	242.9	0.0036
377.17	0.083	243	0.0044
377.20	0.083	243	0.0053
377.23	0.083	243.1	0.0053
377.27	0.085	243.1	0.0053
377.30	0.084	243.2	0.0062
377.33	0.084	243.2	0.0071
377.37	0.085	243.2	0.0071
377.40	0.086	243.3	0.008
377.43	0.086	243.4	0.0089
377.47	0.087	243.4	0.0089
377.50	0.087	243.5	0.0089
377.53	0.088	243.6	0.0098
377.57	0.088	243.6	0.0107
377.60	0.088	243.6	0.0107
377.63	0.09	243.7	0.0124
377.67	0.088	243.7	0.0115
377.72	0.086	243.7	0.0115
377.75	0.088	243.8	0.0124
377.77	0.089	243.9	0.0142
377.80	0.092	244	0.0151
377.83	0.091	244	0.0151
377.87	0.088	244	0.0142
377.90	0.088	244	0.0142
377.93	0.09	244	0.0151
377.97	0.093	244.2	0.0169
378.00	0.093	244.3	0.0169
378.03	0.092	244.3	0.0169
378.07	0.091	244.3	0.0169
378.10	0.092	244.3	0.0169
378.13	0.092	244.3	0.0178
378.17	0.092	244.4	0.0178
378.20	0.093	244.4	0.0186
378.23	0.093	244.5	0.0186
378.27	0.093	244.5	0.0195
378.30	0.093	244.6	0.0195
378.33	0.093	244.6	0.0195
378.37	0.093	244.6	0.0195
378.40	0.094	244.7	0.0204
378.43	0.094	244.7	0.0204
378.47	0.092	244.7	0.0204
378.50	0.096	244.8	0.0222

Prova triassiale ciclica SNME01-C3			
pressione di confinamento (kPa)		380	
deviatore ciclico (kPa)		80	
frequenza (hz)		0.00071429	
tempo	cella di carico	u	LVDT
(min)	kN	(kPa)	δ (mm)
378.53	0.096	244.9	0.0222
378.57	0.095	244.8	0.0222
378.60	0.095	244.8	0.0213
378.63	0.095	244.9	0.0222
378.67	0.095	244.9	0.0222
378.70	0.095	245	0.0231
378.73	0.095	245	0.0231
378.77	0.095	245.1	0.0231
378.80	0.095	245.1	0.0231
378.83	0.095	245.1	0.0231
378.87	0.095	245.1	0.0231
378.90	0.096	245.1	0.0231
378.93	0.096	245.2	0.024
378.97	0.096	245.2	0.024
379.00	0.094	245.2	0.024
379.03	0.097	245.3	0.024
379.07	0.097	245.3	0.0249
379.10	0.097	245.3	0.0249
379.13	0.096	245.3	0.0249
379.18	0.095	245.3	0.0249
379.22	0.096	245.4	0.0249
379.23	0.096	245.4	0.0249
379.27	0.096	245.4	0.0249
379.30	0.096	245.5	0.0257
379.33	0.096	245.4	0.0257
379.37	0.095	245.5	0.0249
379.40	0.095	245.5	0.0257
379.43	0.097	245.5	0.0257
379.47	0.096	245.5	0.0257
379.50	0.092	245.4	0.0249
379.53	0.098	245.7	0.0275
379.57	0.098	245.7	0.0275
379.60	0.092	245.5	0.0266
379.63	0.092	245.5	0.0257
379.67	0.098	245.8	0.0275
379.70	0.098	245.8	0.0266
379.73	0.094	245.7	0.0266
379.77	0.095	245.8	0.0266
379.80	0.095	245.8	0.0266
379.83	0.093	245.7	0.0257
379.87	0.093	245.7	0.0266
379.90	0.096	245.8	0.0266
379.93	0.095	245.8	0.0266
379.97	0.094	245.8	0.0266
380.00	0.094	245.8	0.0266
380.03	0.093	245.8	0.0266
380.07	0.093	245.8	0.0266
380.10	0.093	245.8	0.0266
380.13	0.093	245.9	0.0266
380.17	0.093	245.9	0.0266
380.20	0.093	245.9	0.0266
380.23	0.092	245.8	0.0257
380.27	0.089	245.8	0.0257
380.30	0.094	246	0.0257
380.33	0.094	246	0.0266
380.37	0.092	245.9	0.0257
380.40	0.089	245.8	0.0257
380.43	0.092	245.9	0.0266

Prova triassiale ciclica SNME01-C3			
pressione di confinamento (kPa)		380	
deviatore ciclico (kPa)		80	
frequenza (hz)		0.00071429	
tempo	cella di carico	u	LVDT
(min)	kN	(kPa)	δ (mm)
380.47	0.091	245.9	0.0257
380.50	0.088	245.8	0.0257
380.53	0.091	245.9	0.0257
380.57	0.091	245.9	0.0257
380.62	0.09	245.9	0.0249
380.65	0.089	245.9	0.0249
380.67	0.089	245.9	0.0257
380.70	0.09	245.9	0.0257
380.73	0.089	245.9	0.0249
380.77	0.088	245.9	0.0249
380.80	0.088	245.9	0.0249
380.83	0.087	245.9	0.0249
380.87	0.086	245.9	0.0249
380.90	0.086	245.9	0.0249
380.93	0.087	245.9	0.0249
380.97	0.086	245.9	0.0249
381.00	0.086	245.9	0.024
381.03	0.084	245.8	0.024
381.07	0.085	245.8	0.024
381.10	0.085	245.9	0.024
381.13	0.085	245.9	0.024
381.17	0.084	245.8	0.0231
381.20	0.083	245.8	0.0231
381.23	0.083	245.8	0.0231
381.27	0.082	245.8	0.0231
381.30	0.081	245.8	0.0231
381.33	0.081	245.7	0.0231
381.37	0.081	245.7	0.0222
381.40	0.081	245.8	0.0222
381.43	0.081	245.7	0.0222
381.47	0.079	245.6	0.0222
381.50	0.079	245.6	0.0213
381.53	0.078	245.6	0.0213
381.57	0.078	245.6	0.0213
381.60	0.078	245.6	0.0213
381.63	0.076	245.6	0.0204
381.67	0.077	245.6	0.0204
381.70	0.077	245.6	0.0204
381.73	0.076	245.5	0.0204
381.77	0.074	245.5	0.0204
381.80	0.072	245.4	0.0195
381.83	0.072	245.4	0.0186
381.87	0.075	245.5	0.0195
381.90	0.074	245.4	0.0195
381.93	0.075	245.5	0.0186
381.97	0.072	245.4	0.0178
382.00	0.071	245.3	0.0178
382.03	0.07	245.3	0.0178
382.08	0.07	245.3	0.0169
382.12	0.069	245.3	0.016
382.13	0.067	245.2	0.016
382.17	0.067	245.2	0.016
382.20	0.07	245.3	0.016
382.23	0.069	245.2	0.0151
382.27	0.067	245.1	0.0151
382.30	0.066	245.1	0.0142
382.33	0.066	245.1	0.0142
382.37	0.064	245	0.0142

Prova triassiale ciclica SNME01-C3			
ensione di confinamento (kPa)		380	
deviatore ciclico (kPa)		80	
frequenza (hz)		0.00071429	
tempo	cella di carico	u	LVDT
(min)	kN	(kPa)	δ (mm)
382.40	0.064	245	0.0133
382.43	0.064	245	0.0133
382.47	0.063	245	0.0124
382.50	0.062	244.9	0.0124
382.53	0.062	244.9	0.0115
382.57	0.061	244.9	0.0115
382.60	0.061	244.8	0.0115
382.63	0.061	244.8	0.0107
382.67	0.06	244.8	0.0098
382.70	0.059	244.7	0.0098
382.73	0.058	244.7	0.0089
382.77	0.058	244.7	0.008
382.80	0.056	244.5	0.0071
382.83	0.053	244.5	0.0071
382.87	0.053	244.5	0.0062
382.90	0.055	244.5	0.0062
382.93	0.055	244.5	0.0053
382.97	0.053	244.4	0.0044
383.00	0.053	244.4	0.0044
383.03	0.052	244.3	0.0036
383.07	0.051	244.3	0.0036
383.10	0.051	244.3	0.0027
383.13	0.05	244.2	0.0018
383.17	0.048	244.1	0.0009
383.20	0.048	244.1	0
383.23	0.048	244.1	0
383.27	0.047	244	-0.0009
383.30	0.045	243.9	-0.0009
383.33	0.045	243.9	-0.0018
383.37	0.045	243.9	-0.0027
383.40	0.044	243.9	-0.0036
383.43	0.043	243.8	-0.0044
383.47	0.042	243.7	-0.0053
383.50	0.042	243.7	-0.0062
383.55	0.041	243.6	-0.0062
383.58	0.041	243.6	-0.0071
383.60	0.039	243.5	-0.008
383.63	0.038	243.5	-0.008
383.67	0.038	243.5	-0.0089
383.70	0.037	243.4	-0.0107
383.73	0.036	243.3	-0.0115
383.77	0.036	243.3	-0.0115
383.80	0.035	243.2	-0.0124
383.83	0.033	243.1	-0.0142
383.87	0.033	243.1	-0.0142
383.90	0.033	243.1	-0.0151
383.93	0.033	243.1	-0.016
383.97	0.031	243	-0.0169
384.00	0.03	242.9	-0.0178
384.03	0.03	242.9	-0.0186
384.07	0.028	242.8	-0.0195
384.10	0.027	242.7	-0.0195
384.13	0.027	242.7	-0.0213
384.17	0.027	242.7	-0.0222
384.20	0.026	242.6	-0.0231
384.23	0.025	242.5	-0.024
384.27	0.024	242.5	-0.0249
384.30	0.023	242.4	-0.0266

Prova triassiale ciclica SNME01-C3			
pressione di confinamento (kPa)		380	
deviatore ciclico (kPa)		80	
frequenza (hz)		0.00071429	
tempo	cella di carico	u	LVDT
(min)	kN	(kPa)	δ (mm)
384.33	0.022	242.3	-0.0266
384.37	0.022	242.3	-0.0275
384.40	0.021	242.2	-0.0284
384.43	0.02	242.1	-0.0302
384.47	0.019	242.1	-0.0311
384.50	0.019	242	-0.032
384.53	0.017	241.9	-0.0328
384.57	0.016	241.8	-0.0328
384.60	0.016	241.8	-0.0337
384.63	0.015	241.8	-0.0355
384.67	0.015	241.7	-0.0364
384.70	0.014	241.6	-0.0373
384.73	0.013	241.5	-0.0391
384.77	0.012	241.4	-0.0399
384.80	0.01	241.3	-0.0399
384.83	0.01	241.3	-0.0408
384.87	0.01	241.3	-0.0426
384.90	0.009	241.2	-0.0435
384.93	0.008	241.1	-0.0453
384.98	0.007	241	-0.0462
385.02	0.007	241	-0.047
385.03	0.006	240.9	-0.0479
385.07	0.005	240.8	-0.0488
385.10	0.004	240.7	-0.0506
385.13	0.003	240.7	-0.0506
385.17	0.002	240.7	-0.0515
385.20	0.002	240.6	-0.0533
385.23	0.001	240.5	-0.055
385.27	0	240.4	-0.0568
385.30	-0.001	240.3	-0.0595
385.33	-0.001	240.3	-0.0621
385.37	-0.004	240.1	-0.0621
385.40	-0.003	240.1	-0.0639
385.43	-0.003	240.1	-0.0648
385.47	-0.005	240	-0.0675
385.50	-0.006	239.9	-0.0692
385.53	-0.006	239.8	-0.071
385.57	-0.007	239.7	-0.0728
385.60	-0.009	239.6	-0.0728
385.63	-0.009	239.6	-0.0763
385.67	-0.009	239.5	-0.079
385.70	-0.01	239.4	-0.0826
385.73	-0.012	239.2	-0.0861
385.77	-0.012	239.2	-0.0897
385.80	-0.013	239	-0.0941
385.83	-0.015	238.9	-0.0941
385.87	-0.014	238.9	-0.0994
385.90	-0.014	238.8	-0.1047
385.93	-0.015	238.6	-0.1118
385.97	-0.017	238.5	-0.1207
386.00	-0.018	238.3	-0.1296
386.03	-0.018	238.2	-0.1402
386.07	-0.019	238	-0.1402
386.10	-0.02	238	-0.1536
386.13	-0.02	237.8	-0.166
386.17	-0.021	237.7	-0.1758
386.20	-0.023	237.5	-0.1837
386.23	-0.023	237.3	-0.1891

Prova triassiale ciclica SNME01-C3			
pressione di confinamento (kPa)		380	
deviatore ciclico (kPa)		80	
frequenza (hz)		0.00071429	
tempo	cella di carico	u	LVDT
(min)	kN	(kPa)	δ (mm)
386.27	-0.024	237.2	-0.1944
386.30	-0.025	237	-0.1944
386.33	-0.026	237	-0.1997
386.37	-0.026	236.9	-0.2033
386.40	-0.026	236.8	-0.2068
386.45	-0.028	236.6	-0.2104
386.48	-0.028	236.5	-0.213
386.50	-0.029	236.4	-0.2166
386.53	-0.03	236.2	-0.2201
386.57	-0.031	236.1	-0.2228
386.60	-0.031	236	-0.2246
386.63	-0.032	235.9	-0.2246
386.67	-0.033	235.9	-0.2272
386.70	-0.033	235.8	-0.2281
386.73	-0.033	235.6	-0.2326
386.77	-0.035	235.5	-0.2361
386.80	-0.035	235.4	-0.2388
386.83	-0.036	235.2	-0.2406
386.87	-0.038	235.1	-0.2406
386.90	-0.038	235.1	-0.2441
386.93	-0.038	235	-0.2459
386.97	-0.039	234.9	-0.2485
387.00	-0.04	234.7	-0.2503
387.03	-0.041	234.6	-0.2521
387.07	-0.041	234.5	-0.2548
387.10	-0.042	234.4	-0.2548
387.13	-0.043	234.4	-0.2565
387.17	-0.043	234.3	-0.2592
387.20	-0.043	234.2	-0.261
387.23	-0.045	234.1	-0.2627
387.27	-0.045	234	-0.2645
387.30	-0.046	233.9	-0.2663
387.33	-0.047	233.7	-0.2663
387.37	-0.048	233.7	-0.269
387.40	-0.048	233.6	-0.2707
387.43	-0.048	233.5	-0.2716
387.47	-0.049	233.4	-0.2734
387.50	-0.05	233.3	-0.2761
387.53	-0.051	233.2	-0.2778
387.57	-0.052	233	-0.2778
387.60	-0.052	233	-0.2787
387.63	-0.052	232.9	-0.2805
387.67	-0.052	232.8	-0.2814
387.70	-0.053	232.7	-0.2832
387.73	-0.055	232.6	-0.2858
387.77	-0.055	232.5	-0.2876
387.80	-0.056	232.4	-0.2876
387.83	-0.056	232.4	-0.2894
387.88	-0.057	232.2	-0.292
387.92	-0.058	232.1	-0.292
387.93	-0.058	232.1	-0.2929
387.97	-0.058	232	-0.2938
388.00	-0.059	231.9	-0.2956
388.03	-0.06	231.8	-0.2974
388.07	-0.06	231.7	-0.2982
388.10	-0.06	231.6	-0.2991
388.13	-0.061	231.5	-0.2991
388.17	-0.062	231.5	-0.3009

Prova triassiale ciclica SNME01-C3			
ensione di confinamento (kPa)		380	
deviatore ciclico (kPa)		80	
frequenza (hz)		0.00071429	
tempo	cella di carico	u	LVDT
(min)	kN	(kPa)	δ (mm)
388.20	-0.062	231.4	-0.3018
388.23	-0.062	231.3	-0.3036
388.27	-0.063	231.2	-0.3045
388.30	-0.063	231.1	-0.3053
388.33	-0.064	231	-0.3071
388.37	-0.066	230.9	-0.3071
388.40	-0.065	230.9	-0.308
388.43	-0.065	230.8	-0.3089
388.47	-0.066	230.8	-0.3098
388.50	-0.066	230.6	-0.3116
388.53	-0.067	230.5	-0.3124
388.57	-0.068	230.4	-0.3142
388.60	-0.068	230.4	-0.3142
388.63	-0.069	230.4	-0.3151
388.67	-0.069	230.3	-0.316
388.70	-0.069	230.2	-0.3169
388.73	-0.07	230.1	-0.3178
388.77	-0.07	230	-0.3187
388.80	-0.071	229.9	-0.3196
388.83	-0.072	229.8	-0.3196
388.87	-0.072	229.8	-0.3204
388.90	-0.072	229.7	-0.3213
388.93	-0.072	229.7	-0.3222
388.97	-0.073	229.6	-0.3231
389.00	-0.073	229.5	-0.324
389.03	-0.074	229.4	-0.3249
389.07	-0.074	229.3	-0.3249
389.10	-0.074	229.3	-0.3258
389.13	-0.074	229.3	-0.3267
389.17	-0.075	229.2	-0.3275
389.20	-0.075	229.1	-0.3275
389.23	-0.076	229	-0.3284
389.27	-0.076	229	-0.3293
389.30	-0.077	228.8	-0.3293
389.35	-0.077	228.8	-0.3302
389.38	-0.077	228.8	-0.3311
389.40	-0.078	228.7	-0.3311
389.43	-0.078	228.7	-0.332
389.47	-0.078	228.6	-0.332
389.50	-0.078	228.5	-0.3329
389.53	-0.079	228.5	-0.3338
389.57	-0.079	228.4	-0.3346
389.60	-0.079	228.3	-0.3346
389.63	-0.079	228.3	-0.3346
389.67	-0.08	228.3	-0.3355
389.70	-0.08	228.2	-0.3355
389.73	-0.08	228.2	-0.3364
389.77	-0.081	228.1	-0.3364
389.80	-0.081	228.1	-0.3373
389.83	-0.081	228	-0.3373
389.87	-0.081	227.9	-0.3373
389.90	-0.081	227.9	-0.3382
389.93	-0.081	227.9	-0.3391
389.97	-0.082	227.8	-0.3391
390.00	-0.082	227.8	-0.34
390.03	-0.082	227.7	-0.34
390.07	-0.082	227.7	-0.34
390.10	-0.082	227.7	-0.34

Prova triassiale ciclica SNME01-C3			
pressione di confinamento (kPa)		380	
deviatore ciclico (kPa)		80	
frequenza (hz)		0.00071429	
tempo	cella di carico	u	LVDT
(min)	kN	(kPa)	δ (mm)
390.13	-0.082	227.7	-0.3409
390.17	-0.082	227.6	-0.3409
390.20	-0.083	227.5	-0.3417
390.23	-0.083	227.5	-0.3417
390.27	-0.083	227.5	-0.3417
390.30	-0.083	227.4	-0.3417
390.33	-0.083	227.4	-0.3417
390.37	-0.083	227.4	-0.3426
390.40	-0.083	227.3	-0.3426
390.43	-0.084	227.3	-0.3435
390.47	-0.084	227.3	-0.3435
390.50	-0.084	227.2	-0.3435
390.53	-0.084	227.2	-0.3435
390.57	-0.084	227.2	-0.3435
390.60	-0.084	227.2	-0.3444
390.63	-0.084	227.1	-0.3444
390.67	-0.084	227.1	-0.3444
390.70	-0.084	227.1	-0.3453
390.73	-0.084	227	-0.3453
390.78	-0.085	227	-0.3453
390.82	-0.084	227	-0.3453
390.83	-0.084	227	-0.3453
390.87	-0.084	226.9	-0.3453
390.90	-0.084	226.9	-0.3453
390.93	-0.084	226.9	-0.3453
390.97	-0.084	226.9	-0.3462
391.00	-0.084	226.9	-0.3462
391.03	-0.084	226.9	-0.3462
391.07	-0.084	226.8	-0.3462
391.10	-0.084	226.8	-0.3462
391.13	-0.084	226.8	-0.3462
391.17	-0.084	226.8	-0.3462
391.20	-0.084	226.8	-0.3462
391.23	-0.084	226.7	-0.3462
391.27	-0.084	226.7	-0.3462
391.30	-0.083	226.7	-0.3462
391.33	-0.083	226.7	-0.3462
391.37	-0.083	226.7	-0.3462
391.40	-0.083	226.7	-0.3462
391.43	-0.083	226.7	-0.3462
391.47	-0.083	226.7	-0.3471
391.50	-0.083	226.6	-0.3471
391.53	-0.083	226.7	-0.3462
391.57	-0.082	226.7	-0.3462
391.60	-0.082	226.7	-0.3462
391.63	-0.082	226.7	-0.3462
391.67	-0.082	226.6	-0.3462
391.70	-0.082	226.6	-0.3462
391.73	-0.082	226.6	-0.3462
391.77	-0.082	226.6	-0.3462
391.80	-0.082	226.6	-0.3462
391.83	-0.081	226.6	-0.3462
391.87	-0.081	226.6	-0.3462
391.90	-0.081	226.6	-0.3462
391.93	-0.081	226.6	-0.3462
391.97	-0.08	226.6	-0.3462
392.00	-0.08	226.6	-0.3453
392.03	-0.08	226.6	-0.3453

Prova triassiale ciclica SNME01-C3			
pressione di confinamento (kPa)		380	
deviatore ciclico (kPa)		80	
frequenza (hz)		0.00071429	
tempo	cella di carico	u	LVDT
(min)	kN	(kPa)	δ (mm)
392.07	-0.079	226.7	-0.3453
392.10	-0.079	226.7	-0.3453
392.13	-0.079	226.7	-0.3453
392.17	-0.079	226.7	-0.3453
392.20	-0.079	226.7	-0.3453
392.25	-0.078	226.7	-0.3453
392.28	-0.078	226.7	-0.3453
392.30	-0.078	226.7	-0.3444
392.33	-0.077	226.7	-0.3444
392.37	-0.077	226.7	-0.3444
392.40	-0.077	226.7	-0.3444
392.43	-0.076	226.7	-0.3444
392.47	-0.076	226.8	-0.3435
392.50	-0.076	226.8	-0.3435
392.53	-0.075	226.8	-0.3435
392.57	-0.075	226.8	-0.3426
392.60	-0.075	226.8	-0.3426
392.63	-0.074	226.8	-0.3426
392.67	-0.074	226.8	-0.3426
392.70	-0.074	226.9	-0.3426
392.73	-0.073	226.9	-0.3417
392.77	-0.073	226.9	-0.3417
392.80	-0.072	226.9	-0.3417
392.83	-0.072	227	-0.3409
392.87	-0.071	227	-0.3409
392.90	-0.071	227	-0.3409
392.93	-0.071	227	-0.3409
392.97	-0.07	227.1	-0.34
393.00	-0.07	227.1	-0.34
393.03	-0.069	227.1	-0.3391
393.07	-0.069	227.2	-0.3391
393.10	-0.068	227.2	-0.3391
393.13	-0.068	227.2	-0.3391
393.17	-0.068	227.2	-0.3382
393.20	-0.067	227.3	-0.3382
393.23	-0.067	227.3	-0.3373
393.27	-0.066	227.3	-0.3373
393.30	-0.066	227.4	-0.3364
393.33	-0.065	227.4	-0.3364
393.37	-0.064	227.4	-0.3364
393.40	-0.064	227.5	-0.3355
393.43	-0.064	227.5	-0.3346
393.47	-0.063	227.5	-0.3346
393.50	-0.063	227.6	-0.3338
393.53	-0.062	227.7	-0.3329
393.57	-0.061	227.7	-0.3329
393.60	-0.06	227.7	-0.3329
393.63	-0.06	227.8	-0.332
393.67	-0.06	227.8	-0.332
393.72	-0.059	227.8	-0.3311
393.75	-0.059	227.9	-0.3311
393.77	-0.058	227.9	-0.3302
393.80	-0.057	228	-0.3293
393.83	-0.057	228	-0.3284
393.87	-0.057	228.1	-0.3284
393.90	-0.055	228.2	-0.3284
393.93	-0.055	228.2	-0.3275
393.97	-0.055	228.2	-0.3267

Prova triassiale ciclica SNME01-C3			
pressione di confinamento (kPa)		380	
deviatore ciclico (kPa)		80	
frequenza (hz)		0.00071429	
tempo	cella di carico	u	LVDT
(min)	kN	(kPa)	δ (mm)
394.00	-0.055	228.2	-0.3267
394.03	-0.054	228.3	-0.3258
394.07	-0.053	228.4	-0.3249
394.10	-0.052	228.4	-0.324
394.13	-0.052	228.5	-0.324
394.17	-0.05	228.5	-0.3231
394.20	-0.05	228.6	-0.3222
394.23	-0.05	228.6	-0.3213
394.27	-0.049	228.7	-0.3204
394.30	-0.048	228.7	-0.3196
394.33	-0.048	228.8	-0.3196
394.37	-0.047	228.9	-0.3196
394.40	-0.046	228.9	-0.3178
394.43	-0.046	229	-0.3169
394.47	-0.046	229	-0.316
394.50	-0.045	229.1	-0.3151
394.53	-0.044	229.2	-0.3142
394.57	-0.043	229.3	-0.3133
394.60	-0.042	229.4	-0.3133
394.63	-0.042	229.4	-0.3116
394.67	-0.042	229.4	-0.3107
394.70	-0.041	229.5	-0.3098
394.73	-0.04	229.6	-0.3089
394.77	-0.039	229.7	-0.3071
394.80	-0.038	229.7	-0.3062
394.83	-0.037	229.8	-0.3062
394.87	-0.037	229.8	-0.3053
394.90	-0.037	229.9	-0.3045
394.93	-0.036	230	-0.3027
394.97	-0.035	230.1	-0.3018
395.00	-0.034	230.2	-0.3
395.03	-0.033	230.3	-0.2991
395.07	-0.032	230.3	-0.2991
395.10	-0.032	230.3	-0.2974
395.15	-0.031	230.5	-0.2947
395.18	-0.03	230.6	-0.2947
395.20	-0.029	230.6	-0.2929
395.23	-0.029	230.7	-0.292
395.27	-0.029	230.8	-0.2903
395.30	-0.027	230.9	-0.2885
395.33	-0.027	231	-0.2876
395.37	-0.026	231.1	-0.2858
395.40	-0.025	231.2	-0.2858
395.43	-0.024	231.2	-0.2823
395.47	-0.024	231.3	-0.2805
395.50	-0.024	231.3	-0.2796
395.53	-0.022	231.5	-0.2769
395.57	-0.022	231.5	-0.2761
395.60	-0.02	231.7	-0.2725
395.63	-0.019	231.8	-0.2725
395.67	-0.018	231.8	-0.2698
395.70	-0.018	231.9	-0.2681
395.73	-0.018	231.9	-0.2672
395.77	-0.017	232.1	-0.2645
395.80	-0.016	232.2	-0.2627
395.83	-0.015	232.3	-0.2601
395.87	-0.014	232.4	-0.2601
395.90	-0.014	232.4	-0.2574

Prova triassiale ciclica SNME01-C3			
pressione di confinamento (kPa)		380	
deviatore ciclico (kPa)		80	
frequenza (hz)		0.00071429	
tempo	cella di carico	u	LVDT
(min)	kN	(kPa)	δ (mm)
395.93	-0.014	232.5	-0.2548
395.97	-0.012	232.6	-0.2521
396.00	-0.011	232.7	-0.2494
396.03	-0.01	232.9	-0.2468
396.07	-0.01	233	-0.2441
396.10	-0.009	233.1	-0.2441
396.13	-0.008	233.1	-0.2406
396.17	-0.008	233.2	-0.2379
396.20	-0.007	233.3	-0.2343
396.23	-0.005	233.5	-0.2308
396.27	-0.005	233.6	-0.2272
396.30	-0.004	233.7	-0.2228
396.33	-0.003	233.8	-0.2228
396.37	-0.002	233.8	-0.2201
396.40	-0.002	234	-0.2157
396.43	-0.001	234.1	-0.2113
396.47	0	234.2	-0.2077
396.50	0.001	234.3	-0.2033
396.53	0.002	234.4	-0.1988
396.57	0.002	234.6	-0.1988
396.62	0.003	234.7	-0.19
396.65	0.004	234.9	-0.1846
396.67	0.006	235	-0.1846
396.70	0.006	235	-0.1793
396.73	0.006	235.1	-0.1758
396.77	0.006	235.2	-0.1713
396.80	0.009	235.4	-0.1669
396.83	0.009	235.4	-0.1624
396.87	0.01	235.5	-0.1598
396.90	0.011	235.7	-0.1598
396.93	0.012	235.7	-0.1562
396.97	0.012	235.8	-0.1509
397.00	0.013	235.9	-0.1447
397.03	0.013	236.1	-0.1402
397.07	0.015	236.2	-0.134
397.10	0.015	236.3	-0.1305
397.13	0.017	236.4	-0.1305
397.17	0.017	236.4	-0.1243
397.20	0.017	236.5	-0.1198
397.23	0.018	236.7	-0.1145
397.27	0.02	236.8	-0.1101
397.30	0.02	236.9	-0.1056
397.33	0.021	237	-0.1012
397.37	0.023	237.2	-0.1012
397.40	0.023	237.2	-0.0968
397.43	0.023	237.3	-0.0932
397.47	0.023	237.4	-0.0888
397.50	0.026	237.6	-0.0852
397.53	0.026	237.6	-0.0826
397.57	0.026	237.7	-0.0808
397.60	0.027	237.8	-0.0808
397.63	0.029	237.8	-0.0781
397.67	0.029	237.8	-0.0763
397.70	0.03	237.9	-0.0746
397.73	0.031	238	-0.0728
397.77	0.032	238.1	-0.071
397.80	0.031	238.1	-0.0701
397.83	0.033	238.2	-0.0701

Prova triassiale ciclica SNME01-C3			
pressione di confinamento (kPa)		380	
deviatore ciclico (kPa)		80	
frequenza (hz)		0.00071429	
tempo	cella di carico	u	LVDT
(min)	kN	(kPa)	δ (mm)
397.87	0.034	238.2	-0.0683
397.90	0.034	238.3	-0.0675
397.93	0.034	238.4	-0.0657
397.97	0.036	238.5	-0.0639
398.00	0.036	238.6	-0.063
398.05	0.038	238.7	-0.0612
398.08	0.038	238.7	-0.0604
398.10	0.039	238.8	-0.0595
398.13	0.04	238.9	-0.0586
398.17	0.041	238.9	-0.0586
398.20	0.042	238.9	-0.0559
398.23	0.042	239	-0.055
398.27	0.042	239.1	-0.0541
398.30	0.043	239.2	-0.0524
398.33	0.044	239.3	-0.0515
398.37	0.045	239.3	-0.0497
398.40	0.046	239.4	-0.0497
398.43	0.046	239.4	-0.0488
398.47	0.046	239.5	-0.0479
398.50	0.048	239.6	-0.0462
398.53	0.048	239.7	-0.0453
398.57	0.051	239.8	-0.0435
398.60	0.049	239.8	-0.0435
398.63	0.051	239.9	-0.0435
398.67	0.052	239.9	-0.0417
398.70	0.052	240	-0.0399
398.73	0.052	240.1	-0.0391
398.77	0.053	240.1	-0.0382
398.80	0.054	240.2	-0.0364
398.83	0.056	240.4	-0.0355
398.87	0.056	240.4	-0.0355
398.90	0.057	240.4	-0.0337
398.93	0.057	240.5	-0.0328
398.97	0.057	240.6	-0.032
399.00	0.058	240.6	-0.0311
399.03	0.059	240.7	-0.0302
399.07	0.057	240.7	-0.0302
399.10	0.06	240.8	-0.0302
399.13	0.06	240.8	-0.0284
399.17	0.06	240.9	-0.0275
399.20	0.062	241	-0.0266
399.23	0.063	241.1	-0.0249
399.27	0.063	241.1	-0.024
399.30	0.064	241.2	-0.0231
399.33	0.065	241.3	-0.0231
399.37	0.066	241.3	-0.0222
399.40	0.066	241.4	-0.0213
399.43	0.066	241.5	-0.0204
399.47	0.067	241.6	-0.0186
399.52	0.07	241.7	-0.0169
399.55	0.069	241.8	-0.016
399.57	0.066	241.7	-0.0169
399.60	0.069	241.8	-0.0151
399.63	0.069	241.9	-0.0142
399.67	0.071	242	-0.0142
399.70	0.071	242	-0.0133
399.73	0.071	242.1	-0.0124
399.77	0.072	242.1	-0.0115

Prova triassiale ciclica SNME01-C3			
ensione di confinamento (kPa)		380	
deviatore ciclico (kPa)		80	
frequenza (hz)		0.00071429	
tempo	cella di carico	u	LVDT
(min)	kN	(kPa)	δ (mm)
399.80	0.072	242.2	-0.0107
399.83	0.073	242.3	-0.0098
399.87	0.073	242.4	-0.0089
399.90	0.074	242.4	-0.0089
399.93	0.076	242.4	-0.008
399.97	0.076	242.5	-0.0071
400.00	0.075	242.6	-0.0071
400.03	0.076	242.6	-0.0062
400.07	0.077	242.7	-0.0053
400.10	0.08	242.8	-0.0036
400.13	0.079	242.9	-0.0036
400.17	0.078	242.9	-0.0027
400.20	0.078	242.9	-0.0018
400.23	0.076	242.9	-0.0027
400.27	0.079	243	-0.0009
400.30	0.08	243.1	0
400.33	0.081	243.2	0.0009
400.37	0.081	243.2	0.0009
400.40	0.082	243.2	0.0009
400.43	0.082	243.3	0.0018
400.47	0.082	243.4	0.0027
400.50	0.082	243.4	0.0036
400.53	0.083	243.5	0.0044
400.57	0.084	243.6	0.0053
400.60	0.085	243.6	0.0053
400.63	0.085	243.6	0.0053
400.67	0.085	243.7	0.0062
400.70	0.084	243.7	0.0062
400.73	0.085	243.8	0.0071
400.77	0.086	243.9	0.008
400.80	0.086	243.9	0.0089
400.83	0.086	244	0.0089
400.87	0.087	244	0.0089
400.90	0.087	244.1	0.0098
400.93	0.088	244.1	0.0107
400.98	0.091	244.1	0.0115
401.00	0.091	244.3	0.0124
401.03	0.089	244.3	0.0124
401.07	0.086	244.2	0.0115
401.10	0.089	244.4	0.0124
401.13	0.089	244.4	0.0133
401.17	0.09	244.5	0.0133
401.20	0.091	244.5	0.0142
401.23	0.091	244.5	0.0142
401.27	0.09	244.6	0.0151
401.30	0.091	244.6	0.0151
401.33	0.091	244.7	0.016
401.37	0.092	244.7	0.016
401.40	0.092	244.8	0.016
401.43	0.092	244.8	0.0169
401.47	0.092	244.8	0.0169
401.50	0.092	244.9	0.0169
401.53	0.093	244.9	0.0178
401.57	0.093	245	0.0178
401.60	0.093	245	0.0186
401.63	0.093	245	0.0186
401.67	0.097	245	0.0186
401.70	0.097	245.2	0.0195

Prova triassiale ciclica SNME01-C3			
pressione di confinamento (kPa)		380	
deviatore ciclico (kPa)		80	
frequenza (hz)		0.00071429	
tempo	cella di carico	u	LVDT
(min)	kN	(kPa)	δ (mm)
401.73	0.092	245.1	0.0186
401.77	0.092	245.1	0.0195
401.80	0.094	245.2	0.0204
401.83	0.094	245.3	0.0204
401.87	0.095	245.3	0.0204
401.90	0.094	245.3	0.0204
401.93	0.094	245.3	0.0204
401.97	0.095	245.4	0.0213
402.00	0.095	245.4	0.0213
402.03	0.095	245.5	0.0213
402.07	0.095	245.5	0.0222
402.10	0.095	245.5	0.0222
402.13	0.095	245.5	0.0222
402.17	0.095	245.6	0.0222
402.20	0.096	245.6	0.0231
402.23	0.096	245.6	0.0231
402.27	0.096	245.7	0.0231
402.30	0.097	245.8	0.024
402.33	0.098	245.8	0.024
402.37	0.096	245.8	0.024
402.42	0.096	245.8	0.024
402.45	0.094	245.8	0.024
402.47	0.095	245.9	0.0231
402.50	0.095	245.9	0.024
402.53	0.095	245.9	0.024
402.57	0.096	245.9	0.0249
402.60	0.096	246	0.0249
402.63	0.096	246	0.0249
402.67	0.096	246	0.0249
402.70	0.095	246	0.0249
402.73	0.095	246	0.0249
402.77	0.096	246.1	0.0249
402.80	0.096	246.1	0.0249
402.83	0.095	246.1	0.0249
402.87	0.095	246.1	0.0249
402.90	0.095	246.2	0.0249
402.93	0.095	246.2	0.0249
402.97	0.095	246.2	0.0249
403.00	0.098	246.3	0.0257
403.03	0.094	246.2	0.0249
403.07	0.094	246.2	0.0249
403.10	0.095	246.2	0.0257
403.13	0.095	246.3	0.0257
403.17	0.095	246.3	0.0257
403.20	0.095	246.3	0.0257
403.23	0.095	246.3	0.0257
403.27	0.094	246.3	0.0257
403.30	0.094	246.3	0.0257
403.33	0.097	246.4	0.0257
403.37	0.091	246.3	0.0257
403.40	0.093	246.3	0.0249
403.43	0.093	246.3	0.0257
403.47	0.093	246.4	0.0257
403.50	0.093	246.4	0.0257
403.53	0.093	246.4	0.0257
403.57	0.092	246.4	0.0249
403.60	0.092	246.4	0.0249
403.63	0.092	246.4	0.0249

Prova triassiale ciclica SNME01-C3			
pressione di confinamento (kPa)		380	
deviatore ciclico (kPa)		80	
frequenza (hz)		0.00071429	
tempo	cella di carico	u	LVDT
(min)	kN	(kPa)	δ (mm)
403.67	0.092	246.4	0.0249
403.70	0.092	246.4	0.0249
403.73	0.091	246.4	0.0249
403.77	0.091	246.4	0.0249
403.80	0.091	246.4	0.0249
403.83	0.09	246.4	0.0249
403.88	0.09	246.4	0.0249
403.92	0.089	246.4	0.0249
403.93	0.092	246.5	0.0249
403.97	0.091	246.5	0.0249
404.00	0.091	246.5	0.0249
404.03	0.089	246.4	0.024
404.07	0.088	246.4	0.024
404.10	0.085	246.3	0.0231
404.13	0.087	246.4	0.024
404.17	0.088	246.4	0.024
404.20	0.087	246.4	0.024
404.23	0.087	246.4	0.024
404.27	0.087	246.4	0.024
404.30	0.086	246.4	0.024
404.33	0.085	246.4	0.0231
404.37	0.086	246.4	0.0231
404.40	0.084	246.3	0.0231
404.43	0.084	246.3	0.0231
404.47	0.084	246.3	0.0231
404.50	0.084	246.3	0.0231
404.53	0.083	246.3	0.0222
404.57	0.083	246.3	0.0222
404.60	0.082	246.3	0.0222
404.63	0.084	246.4	0.0222
404.67	0.082	246.3	0.0231
404.70	0.082	246.3	0.0222
404.73	0.079	246.2	0.0204
404.77	0.079	246.2	0.0204
404.80	0.08	246.2	0.0213
404.83	0.08	246.2	0.0204
404.87	0.079	246.1	0.0204
404.90	0.078	246.1	0.0204
404.93	0.078	246.1	0.0204
404.97	0.078	246.1	0.0195
405.00	0.077	246.1	0.0195
405.03	0.076	246.1	0.0195
405.07	0.076	246.1	0.0186
405.10	0.075	246	0.0186
405.13	0.074	246	0.0186
405.17	0.074	246	0.0186
405.20	0.074	246	0.0178
405.23	0.073	246	0.0178
405.27	0.073	245.9	0.0178
405.32	0.072	245.9	0.0169
405.35	0.072	245.9	0.0169
405.37	0.07	245.8	0.0169
405.40	0.073	245.9	0.0169
405.43	0.071	245.8	0.0169
405.47	0.069	245.8	0.016
405.50	0.069	245.8	0.0151
405.53	0.068	245.7	0.0142
405.57	0.067	245.7	0.0142

Prova triassiale ciclica SNME01-C3			
pressione di confinamento (kPa)		380	
deviatore ciclico (kPa)		80	
frequenza (hz)		0.00071429	
tempo	cella di carico	u	LVDT
(min)	kN	(kPa)	δ (mm)
405.60	0.065	245.6	0.0133
405.63	0.065	245.6	0.0133
405.67	0.066	245.6	0.0133
405.70	0.065	245.5	0.0124
405.73	0.065	245.5	0.0124
405.77	0.065	245.5	0.0115
405.80	0.063	245.4	0.0115
405.83	0.062	245.4	0.0107
405.87	0.062	245.4	0.0107
405.90	0.061	245.3	0.0107
405.93	0.06	245.3	0.0098
405.97	0.06	245.3	0.0089
406.00	0.059	245.3	0.0089
406.03	0.059	245.2	0.008
406.07	0.058	245.2	0.0071
406.10	0.058	245.2	0.0071
406.13	0.056	245.1	0.0071
406.17	0.056	245.1	0.0062
406.20	0.056	245.1	0.0062
406.23	0.055	245	0.0053
406.27	0.054	245	0.0044
406.30	0.053	244.9	0.0044
406.33	0.055	245	0.0044
406.37	0.053	244.9	0.0044
406.40	0.048	244.7	0.0027
406.43	0.048	244.7	0.0009
406.47	0.05	244.7	0.0009
406.50	0.049	244.7	0
406.53	0.049	244.6	-0.0009
406.57	0.048	244.6	-0.0018
406.60	0.047	244.5	-0.0018
406.63	0.046	244.4	-0.0027
406.67	0.046	244.4	-0.0036
406.70	0.045	244.4	-0.0036
406.73	0.045	244.4	-0.0044
406.78	0.043	244.3	-0.0053
406.82	0.043	244.3	-0.0062
406.83	0.042	244.2	-0.0071
406.87	0.041	244.1	-0.008
406.90	0.042	244.1	-0.008
406.93	0.04	244	-0.008
406.97	0.036	243.9	-0.0089
407.00	0.036	243.9	-0.0115
407.03	0.037	243.9	-0.0115
407.07	0.037	243.9	-0.0124
407.10	0.036	243.8	-0.0133
407.13	0.035	243.7	-0.0142
407.17	0.034	243.7	-0.0142
407.20	0.033	243.6	-0.0151
407.23	0.033	243.6	-0.016
407.27	0.032	243.5	-0.0169
407.30	0.031	243.4	-0.0178
407.33	0.031	243.4	-0.0186
407.37	0.03	243.4	-0.0195
407.40	0.029	243.3	-0.0195
407.43	0.027	243.2	-0.0204
407.47	0.027	243.2	-0.0222
407.50	0.027	243.1	-0.0231

Prova triassiale ciclica SNME01-C3			
pressione di confinamento (kPa)		380	
deviatore ciclico (kPa)		80	
frequenza (hz)		0.00071429	
tempo	cella di carico	u	LVDT
(min)	kN	(kPa)	δ (mm)
407.53	0.026	243	-0.024
407.57	0.025	243	-0.0249
407.60	0.025	242.9	-0.0266
407.63	0.023	242.8	-0.0266
407.67	0.022	242.8	-0.0275
407.70	0.022	242.8	-0.0284
407.73	0.024	242.8	-0.0284
407.77	0.021	242.7	-0.0302
407.80	0.019	242.6	-0.032
407.83	0.016	242.4	-0.0337
407.87	0.016	242.4	-0.0337
407.90	0.017	242.3	-0.0346
407.93	0.017	242.3	-0.0355
407.97	0.016	242.2	-0.0373
408.00	0.014	242.1	-0.0382
408.03	0.014	242.1	-0.0391
408.07	0.013	242	-0.0408
408.10	0.012	241.9	-0.0408
408.13	0.01	241.8	-0.0417
408.17	0.01	241.8	-0.0426
408.22	0.009	241.7	-0.0444
408.25	0.009	241.6	-0.0453
408.27	0.009	241.6	-0.0453
408.30	0.01	241.7	-0.047
408.33	0.004	241.3	-0.0497
408.37	0.004	241.3	-0.0506
408.40	0.005	241.3	-0.0515
408.43	0.004	241.2	-0.0515
408.47	0.003	241.1	-0.0524
408.50	0.003	241.1	-0.0533
408.53	0.002	241	-0.055
408.57	0.001	240.9	-0.0568
408.60	0.003	241	-0.0568
408.63	0	240.8	-0.0612
408.67	-0.005	240.6	-0.0612
408.70	-0.004	240.6	-0.0648
408.73	-0.004	240.6	-0.0666
408.77	-0.005	240.5	-0.0675
408.80	-0.005	240.4	-0.0692
408.83	-0.006	240.3	-0.0701
408.87	-0.007	240.2	-0.0728
408.90	-0.008	240.1	-0.0728
408.93	-0.009	240	-0.0746
408.97	-0.009	240	-0.0772
409.00	-0.009	239.9	-0.0799
409.03	-0.011	239.8	-0.0826
409.07	-0.009	239.8	-0.0843
409.10	-0.012	239.6	-0.0897
409.13	-0.014	239.4	-0.0897
409.17	-0.014	239.3	-0.095
409.20	-0.014	239.3	-0.1003
409.23	-0.016	239.2	-0.1065
409.27	-0.017	239	-0.1127
409.30	-0.017	238.9	-0.1198
409.33	-0.017	238.8	-0.1278
409.37	-0.019	238.7	-0.1278
409.40	-0.019	238.5	-0.1385
409.43	-0.019	238.5	-0.1527

Prova triassiale ciclica SNME01-C3			
pressione di confinamento (kPa)		380	
deviatore ciclico (kPa)		80	
frequenza (hz)		0.00071429	
tempo	cella di carico	u	LVDT
(min)	kN	(kPa)	δ (mm)
409.47	-0.018	238.4	-0.1633
409.50	-0.021	238.1	-0.1758
409.53	-0.025	237.8	-0.1908
409.57	-0.023	237.7	-0.1935
409.60	-0.023	237.6	-0.1935
409.63	-0.026	237.4	-0.1971
409.68	-0.025	237.4	-0.2042
409.72	-0.024	237.4	-0.2042
409.73	-0.027	237.1	-0.2042
409.77	-0.027	237.1	-0.213
409.80	-0.029	236.9	-0.2175
409.83	-0.031	236.7	-0.221
409.87	-0.029	236.7	-0.221
409.90	-0.03	236.6	-0.2246
409.93	-0.032	236.3	-0.2246
409.97	-0.032	236.3	-0.2308
410.00	-0.032	236.3	-0.2326
410.03	-0.033	236.2	-0.2326
410.07	-0.036	235.9	-0.237
410.10	-0.034	235.9	-0.2388
410.13	-0.037	235.6	-0.2441
410.17	-0.038	235.5	-0.2441
410.20	-0.038	235.5	-0.2459
410.23	-0.038	235.5	-0.2468
410.27	-0.036	235.5	-0.2459
410.30	-0.039	235.3	-0.2494
410.33	-0.039	235.2	-0.2539
410.37	-0.042	235	-0.2565
410.40	-0.042	234.8	-0.2565
410.43	-0.042	234.8	-0.2583
410.47	-0.042	234.8	-0.2592
410.50	-0.043	234.7	-0.2619
410.53	-0.044	234.5	-0.2636
410.57	-0.045	234.4	-0.2654
410.60	-0.045	234.3	-0.2672
410.63	-0.046	234.2	-0.2672
410.67	-0.047	234.1	-0.2698
410.70	-0.047	234.1	-0.2707
410.73	-0.048	234	-0.2725
410.77	-0.049	233.9	-0.2752
410.80	-0.05	233.8	-0.2761
410.83	-0.05	233.7	-0.2778
410.87	-0.051	233.6	-0.2778
410.90	-0.052	233.4	-0.2796
410.93	-0.052	233.4	-0.2814
410.97	-0.052	233.4	-0.2823
411.00	-0.053	233.3	-0.284
411.03	-0.054	233.1	-0.2867
411.07	-0.054	233	-0.2876
411.10	-0.055	232.9	-0.2876
411.15	-0.056	232.8	-0.2903
411.18	-0.056	232.7	-0.292
411.20	-0.057	232.6	-0.2938
411.23	-0.058	232.5	-0.2938
411.27	-0.058	232.5	-0.2947
411.30	-0.058	232.4	-0.2956
411.33	-0.059	232.3	-0.2974
411.37	-0.059	232.2	-0.2982

Prova triassiale ciclica SNME01-C3			
ensione di confinamento (kPa)		380	
deviatore ciclico (kPa)		80	
frequenza (hz)		0.00071429	
tempo	cella di carico	u	LVDT
(min)	kN	(kPa)	δ (mm)
411.40	-0.06	232.1	-0.3
411.43	-0.061	232	-0.3018
411.47	-0.061	231.9	-0.3018
411.50	-0.061	231.9	-0.3027
411.53	-0.063	231.8	-0.3036
411.57	-0.062	231.7	-0.3045
411.60	-0.063	231.6	-0.3062
411.63	-0.064	231.5	-0.3071
411.67	-0.064	231.4	-0.308
411.70	-0.065	231.3	-0.308
411.73	-0.065	231.3	-0.3089
411.77	-0.066	231.2	-0.3107
411.80	-0.066	231.1	-0.3116
411.83	-0.067	231	-0.3124
411.87	-0.067	230.9	-0.3142
411.90	-0.068	230.8	-0.3151
411.93	-0.069	230.7	-0.3151
411.97	-0.069	230.7	-0.316
412.00	-0.069	230.7	-0.3169
412.03	-0.069	230.6	-0.3187
412.07	-0.07	230.5	-0.3196
412.10	-0.07	230.4	-0.3196
412.13	-0.071	230.3	-0.3204
412.17	-0.072	230.3	-0.3204
412.20	-0.072	230.3	-0.3213
412.23	-0.072	230.2	-0.3222
412.27	-0.072	230.1	-0.3231
412.30	-0.073	230	-0.324
412.33	-0.074	229.9	-0.3249
412.37	-0.073	229.8	-0.3249
412.40	-0.074	229.7	-0.3258
412.43	-0.074	229.7	-0.3267
412.47	-0.074	229.7	-0.3275
412.50	-0.075	229.6	-0.3275
412.53	-0.076	229.5	-0.3284
412.58	-0.075	229.5	-0.3293
412.62	-0.076	229.4	-0.3302
412.63	-0.076	229.3	-0.3311
412.67	-0.077	229.2	-0.3311
412.70	-0.077	229.2	-0.332
412.73	-0.077	229.1	-0.332
412.77	-0.077	229.1	-0.3329
412.80	-0.078	229	-0.3338
412.83	-0.078	229	-0.3338
412.87	-0.078	228.9	-0.3346
412.90	-0.079	228.8	-0.3355
412.93	-0.08	228.7	-0.3364
412.97	-0.079	228.7	-0.3364
413.00	-0.079	228.7	-0.3364
413.03	-0.08	228.6	-0.3373
413.07	-0.08	228.6	-0.3373
413.10	-0.08	228.5	-0.3373
413.13	-0.08	228.5	-0.3382
413.17	-0.081	228.4	-0.3391
413.20	-0.081	228.3	-0.3391
413.23	-0.081	228.3	-0.3391
413.27	-0.082	228.3	-0.34
413.30	-0.081	228.3	-0.34

Prova triassiale ciclica SNME01-C3			
ensione di confinamento (kPa)		380	
deviatore ciclico (kPa)		80	
frequenza (hz)		0.00071429	
tempo	cella di carico	u	LVDT
(min)	kN	(kPa)	δ (mm)
413.33	-0.082	228.2	-0.3409
413.37	-0.082	228.1	-0.3409
413.40	-0.082	228.1	-0.3409
413.43	-0.082	228.1	-0.3409
413.47	-0.082	228.1	-0.3417
413.50	-0.083	228	-0.3417
413.53	-0.083	228	-0.3417
413.57	-0.083	227.9	-0.3426
413.60	-0.083	227.9	-0.3426
413.63	-0.083	227.8	-0.3435
413.67	-0.083	227.8	-0.3435
413.70	-0.083	227.8	-0.3435
413.73	-0.084	227.7	-0.3435
413.77	-0.084	227.7	-0.3444
413.80	-0.084	227.7	-0.3444
413.83	-0.084	227.6	-0.3444
413.87	-0.084	227.6	-0.3444
413.90	-0.084	227.5	-0.3444
413.93	-0.084	227.5	-0.3453
413.97	-0.084	227.5	-0.3453
414.00	-0.084	227.5	-0.3453
414.05	-0.084	227.5	-0.3453
414.08	-0.084	227.4	-0.3462
414.10	-0.084	227.4	-0.3462
414.13	-0.084	227.4	-0.3462
414.17	-0.084	227.3	-0.3462
414.20	-0.085	227.3	-0.3471
414.23	-0.084	227.3	-0.3471
414.27	-0.084	227.3	-0.3471
414.30	-0.084	227.3	-0.3471
414.33	-0.084	227.2	-0.3471
414.37	-0.084	227.2	-0.3471
414.40	-0.084	227.2	-0.3471
414.43	-0.084	227.2	-0.3471
414.47	-0.084	227.2	-0.3471
414.50	-0.084	227.2	-0.3471
414.53	-0.084	227.2	-0.3471
414.57	-0.084	227.2	-0.3471
414.60	-0.083	227.1	-0.3471
414.63	-0.083	227.1	-0.3471
414.67	-0.084	227.1	-0.3471
414.70	-0.084	227.1	-0.3471
414.73	-0.083	227.1	-0.3471
414.77	-0.083	227.1	-0.348
414.80	-0.083	227.1	-0.3471
414.83	-0.083	227.1	-0.3471
414.87	-0.083	227	-0.3471
414.90	-0.082	227.1	-0.3471
414.93	-0.082	227	-0.3471
414.97	-0.082	227	-0.3471
415.00	-0.082	227	-0.3471
415.03	-0.082	227	-0.3471
415.07	-0.082	227	-0.3471
415.10	-0.082	227	-0.3471
415.13	-0.082	227	-0.3471
415.17	-0.081	227	-0.3471
415.20	-0.081	227	-0.3471
415.23	-0.081	227	-0.3471

Prova triassiale ciclica SNME01-C3			
ensione di confinamento (kPa)		380	
deviatore ciclico (kPa)		80	
frequenza (hz)		0.00071429	
tempo	cella di carico	u	LVDT
(min)	kN	(kPa)	δ (mm)
415.27	-0.08	227	-0.3471
415.30	-0.08	227	-0.3471
415.33	-0.08	227	-0.3471
415.37	-0.08	227	-0.3462
415.40	-0.079	227.1	-0.3462
415.43	-0.079	227.1	-0.3462
415.48	-0.079	227	-0.3462
415.52	-0.078	227.1	-0.3462
415.53	-0.078	227.1	-0.3462
415.57	-0.078	227.1	-0.3462
415.60	-0.078	227.1	-0.3462
415.63	-0.077	227.1	-0.3453
415.67	-0.077	227.1	-0.3453
415.70	-0.077	227.1	-0.3453
415.73	-0.077	227.1	-0.3453
415.77	-0.076	227.1	-0.3444
415.80	-0.076	227.1	-0.3444
415.83	-0.075	227.2	-0.3444
415.87	-0.075	227.2	-0.3444
415.90	-0.075	227.2	-0.3444
415.93	-0.075	227.2	-0.3435
415.97	-0.074	227.2	-0.3435
416.00	-0.074	227.2	-0.3435
416.03	-0.074	227.3	-0.3435
416.07	-0.074	227.3	-0.3426
416.10	-0.072	227.3	-0.3426
416.13	-0.072	227.3	-0.3426
416.17	-0.072	227.4	-0.3417
416.20	-0.071	227.4	-0.3417
416.23	-0.071	227.4	-0.3417
416.27	-0.071	227.4	-0.3417
416.30	-0.071	227.5	-0.3409
416.33	-0.07	227.5	-0.3409
416.37	-0.069	227.5	-0.34
416.40	-0.069	227.5	-0.34
416.43	-0.068	227.6	-0.34
416.47	-0.068	227.6	-0.3391
416.50	-0.068	227.6	-0.3391
416.53	-0.067	227.7	-0.3382
416.57	-0.066	227.7	-0.3382
416.60	-0.066	227.7	-0.3382
416.63	-0.066	227.8	-0.3373
416.67	-0.065	227.8	-0.3373
416.70	-0.064	227.8	-0.3364
416.73	-0.064	227.9	-0.3364
416.77	-0.064	227.9	-0.3355
416.80	-0.063	227.9	-0.3355
416.83	-0.062	228	-0.3346
416.87	-0.062	228	-0.3346
416.90	-0.061	228.1	-0.3346
416.95	-0.061	228.1	-0.3338
416.98	-0.06	228.2	-0.3329
417.00	-0.06	228.2	-0.3329
417.03	-0.059	228.2	-0.332
417.07	-0.059	228.3	-0.332
417.10	-0.059	228.3	-0.3311
417.13	-0.057	228.4	-0.3302
417.17	-0.057	228.4	-0.3293

Prova triassiale ciclica SNME01-C3			
pressione di confinamento (kPa)		380	
deviatore ciclico (kPa)		80	
frequenza (hz)		0.00071429	
tempo	cella di carico	u	LVDT
(min)	kN	(kPa)	δ (mm)
417.20	-0.057	228.5	-0.3293
417.23	-0.055	228.5	-0.3293
417.27	-0.055	228.5	-0.3284
417.30	-0.055	228.6	-0.3275
417.33	-0.054	228.7	-0.3267
417.37	-0.053	228.7	-0.3258
417.40	-0.053	228.8	-0.3249
417.43	-0.052	228.8	-0.3249
417.47	-0.052	228.9	-0.3249
417.50	-0.05	228.9	-0.324
417.53	-0.05	229	-0.3231
417.57	-0.05	229	-0.3222
417.60	-0.049	229.1	-0.3213
417.63	-0.049	229.1	-0.3204
417.67	-0.047	229.3	-0.3196
417.70	-0.047	229.3	-0.3196
417.73	-0.046	229.3	-0.3187
417.77	-0.046	229.4	-0.3178
417.80	-0.046	229.5	-0.3169
417.83	-0.044	229.6	-0.316
417.87	-0.044	229.6	-0.3151
417.90	-0.043	229.7	-0.3133
417.93	-0.042	229.7	-0.3133
417.97	-0.041	229.7	-0.3124
418.00	-0.041	229.8	-0.3116
418.03	-0.041	229.9	-0.3107
418.07	-0.039	230.1	-0.3089
418.10	-0.039	230.1	-0.308
418.13	-0.038	230.2	-0.3062
418.17	-0.037	230.3	-0.3062
418.20	-0.036	230.3	-0.3053
418.23	-0.036	230.3	-0.3045
418.27	-0.036	230.4	-0.3036
418.30	-0.035	230.5	-0.3018
418.33	-0.034	230.6	-0.3009
418.37	-0.033	230.7	-0.2991
418.42	-0.033	230.8	-0.2982
418.43	-0.032	230.8	-0.2965
418.47	-0.032	230.9	-0.2956
418.50	-0.03	231	-0.2956
418.53	-0.029	231	-0.2938
418.57	-0.029	231.1	-0.292
418.60	-0.028	231.2	-0.2903
418.63	-0.028	231.3	-0.2894
418.67	-0.027	231.4	-0.2876
418.70	-0.026	231.5	-0.284
418.73	-0.025	231.6	-0.284
418.77	-0.024	231.6	-0.2832
418.80	-0.024	231.7	-0.2814
418.83	-0.023	231.8	-0.2787
418.87	-0.022	231.9	-0.2769
418.90	-0.021	232	-0.2752
418.93	-0.021	232.1	-0.2734
418.97	-0.02	232.2	-0.2734
419.00	-0.019	232.2	-0.2716
419.03	-0.019	232.3	-0.269
419.07	-0.018	232.4	-0.2672
419.10	-0.016	232.5	-0.2636

Prova triassiale ciclica SNME01-C3			
pressione di confinamento (kPa)		380	
deviatore ciclico (kPa)		80	
frequenza (hz)		0.00071429	
tempo	cella di carico	u	LVDT
(min)	kN	(kPa)	δ (mm)
419.13	-0.016	232.6	-0.2619
419.17	-0.015	232.7	-0.2601
419.20	-0.014	232.8	-0.2601
419.23	-0.013	232.8	-0.2574
419.27	-0.013	232.9	-0.2556
419.30	-0.012	233	-0.253
419.33	-0.011	233.2	-0.2494
419.37	-0.011	233.3	-0.2468
419.40	-0.009	233.4	-0.2432
419.43	-0.007	233.6	-0.2432
419.47	-0.008	233.6	-0.2397
419.50	-0.008	233.6	-0.2379
419.53	-0.007	233.7	-0.2343
419.57	-0.005	233.9	-0.2299
419.60	-0.004	234	-0.2263
419.63	-0.004	234.1	-0.2237
419.67	-0.003	234.2	-0.2237
419.70	-0.002	234.2	-0.2192
419.73	-0.002	234.3	-0.2166
419.77	-0.001	234.5	-0.2113
419.80	0	234.6	-0.2068
419.85	0.002	234.8	-0.2024
419.88	0.001	234.8	-0.1997
419.90	0.002	234.9	-0.1962
419.93	0.003	235	-0.1917
419.97	0.003	235.1	-0.1882
420.00	0.006	235.3	-0.1882
420.03	0.006	235.3	-0.1829
420.07	0.006	235.4	-0.1793
420.10	0.006	235.5	-0.1749
420.13	0.008	235.7	-0.1695
420.17	0.009	235.9	-0.1633
420.20	0.009	235.9	-0.158
420.23	0.011	236.1	-0.158
420.27	0.011	236.1	-0.1527
420.30	0.011	236.2	-0.1473
420.33	0.012	236.4	-0.142
420.37	0.015	236.5	-0.1358
420.40	0.015	236.6	-0.1323
420.43	0.015	236.7	-0.1278
420.47	0.017	236.9	-0.1278
420.50	0.017	236.9	-0.1225
420.53	0.017	237	-0.1181
420.57	0.018	237.1	-0.1136
420.60	0.02	237.3	-0.1083
420.63	0.02	237.4	-0.1047
420.67	0.021	237.5	-0.1012
420.70	0.022	237.6	-0.1012
420.73	0.023	237.6	-0.0968
420.77	0.023	237.7	-0.0932
420.80	0.024	237.9	-0.0888
420.83	0.026	238	-0.0852
420.87	0.026	238.1	-0.0834
420.90	0.026	238.1	-0.0808
420.93	0.029	238.2	-0.0808
420.97	0.029	238.2	-0.079
421.00	0.029	238.3	-0.0763
421.03	0.029	238.3	-0.0754

Prova triassiale ciclica SNME01-C3			
pressione di confinamento (kPa)		380	
deviatore ciclico (kPa)		80	
frequenza (hz)		0.00071429	
tempo	cella di carico	u	LVDT
(min)	kN	(kPa)	δ (mm)
421.07	0.031	238.4	-0.0737
421.10	0.031	238.5	-0.0719
421.13	0.032	238.6	-0.0701
421.17	0.034	238.7	-0.0701
421.20	0.034	238.7	-0.0683
421.23	0.034	238.8	-0.0675
421.27	0.035	238.9	-0.0657
421.32	0.036	238.9	-0.0648
421.35	0.036	239	-0.0639
421.37	0.038	239.1	-0.0612
421.40	0.039	239.2	-0.0604
421.43	0.039	239.2	-0.0595
421.47	0.039	239.3	-0.0586
421.50	0.041	239.4	-0.0586
421.53	0.04	239.4	-0.0568
421.57	0.04	239.4	-0.0559
421.60	0.042	239.5	-0.0541
421.63	0.045	239.7	-0.0524
421.67	0.044	239.7	-0.0515
421.70	0.045	239.8	-0.0506
421.73	0.046	239.9	-0.0506
421.77	0.047	239.9	-0.0488
421.80	0.047	239.9	-0.0479
421.83	0.047	240	-0.047
421.87	0.048	240.1	-0.0462
421.90	0.05	240.2	-0.0444
421.93	0.05	240.2	-0.0435
421.97	0.053	240.5	-0.0435
422.00	0.052	240.5	-0.0408
422.03	0.052	240.4	-0.0399
422.07	0.053	240.5	-0.0399
422.10	0.051	240.5	-0.0391
422.13	0.054	240.6	-0.0382
422.17	0.054	240.7	-0.0364
422.20	0.056	240.8	-0.0364
422.23	0.057	240.8	-0.0355
422.27	0.057	240.9	-0.0337
422.30	0.057	241	-0.0328
422.33	0.059	241.1	-0.032
422.37	0.058	241.1	-0.0311
422.40	0.059	241.2	-0.0293
422.43	0.061	241.3	-0.0293
422.47	0.061	241.3	-0.0284
422.50	0.061	241.4	-0.0275
422.53	0.061	241.4	-0.0266
422.57	0.063	241.6	-0.0257
422.60	0.063	241.6	-0.0249
422.63	0.064	241.7	-0.0231
422.67	0.065	241.8	-0.0231
422.70	0.065	241.8	-0.0222
422.75	0.066	241.9	-0.0204
422.78	0.07	242.1	-0.0204
422.80	0.065	242.1	-0.0186
422.83	0.065	242	-0.0186
422.87	0.068	242.2	-0.0178
422.90	0.07	242.3	-0.016
422.93	0.069	242.3	-0.016
422.97	0.07	242.4	-0.0151

Prova triassiale ciclica SNME01-C3			
ensione di confinamento (kPa)		380	
deviatore ciclico (kPa)		80	
frequenza (hz)		0.00071429	
tempo	cella di carico	u	LVDT
(min)	kN	(kPa)	δ (mm)
423.00	0.071	242.5	-0.0151
423.03	0.071	242.5	-0.0142
423.07	0.071	242.5	-0.0133
423.10	0.072	242.6	-0.0124
423.13	0.073	242.7	-0.0115
423.17	0.073	242.7	-0.0107
423.20	0.073	242.8	-0.0098
423.23	0.075	242.9	-0.0098
423.27	0.075	242.9	-0.0089
423.30	0.075	242.9	-0.008
423.33	0.075	243	-0.0071
423.37	0.077	243.1	-0.0062
423.40	0.077	243.2	-0.0053
423.43	0.077	243.2	-0.0044
423.47	0.078	243.3	-0.0044
423.50	0.081	243.3	-0.0027
423.53	0.081	243.5	-0.0018
423.57	0.079	243.3	-0.0027
423.60	0.077	243.4	-0.0018
423.63	0.079	243.5	-0.0009
423.67	0.08	243.6	0
423.70	0.081	243.7	0
423.73	0.082	243.7	0.0009
423.77	0.082	243.7	0.0018
423.80	0.082	243.8	0.0018
423.83	0.086	244	0.0044
423.87	0.084	244	0.0044
423.90	0.084	244	0.0053
423.93	0.084	244.1	0.0053
423.97	0.081	244.1	0.0053
424.00	0.081	244.1	0.0062
424.03	0.085	244.2	0.0071
424.07	0.088	244.3	0.0089
424.10	0.086	244.3	0.008
424.13	0.086	244.4	0.0089
424.17	0.089	244.5	0.0089
424.22	0.089	244.6	0.0107
424.25	0.087	244.6	0.0107
424.27	0.085	244.5	0.0107
424.30	0.09	244.5	0.0098
424.33	0.09	244.7	0.0115
424.37	0.089	244.7	0.0124
424.40	0.089	244.8	0.0124
424.43	0.088	244.8	0.0124
424.47	0.091	244.9	0.0133
424.50	0.091	245	0.0133
424.53	0.091	245	0.0142
424.57	0.091	245	0.0142
424.60	0.091	245.1	0.0151
424.63	0.091	245.1	0.0151
424.67	0.091	245.1	0.0151
424.70	0.092	245.2	0.016
424.73	0.092	245.2	0.016
424.77	0.092	245.2	0.016
424.80	0.092	245.3	0.016
424.83	0.092	245.3	0.0169
424.87	0.093	245.4	0.0169
424.90	0.091	245.3	0.0169

Prova triassiale ciclica SNME01-C3			
ensione di confinamento (kPa)		380	
deviatore ciclico (kPa)		80	
frequenza (hz)		0.00071429	
tempo	cella di carico	u	LVDT
(min)	kN	(kPa)	δ (mm)
424.93	0.095	245.5	0.0186
424.97	0.095	245.6	0.0186
425.00	0.093	245.6	0.0186
425.03	0.093	245.6	0.0186
425.07	0.092	245.5	0.0186
425.10	0.095	245.7	0.0195
425.13	0.094	245.7	0.0195
425.17	0.095	245.8	0.0204
425.20	0.095	245.8	0.0204
425.23	0.095	245.8	0.0204
425.27	0.095	245.8	0.0204
425.30	0.095	245.9	0.0204
425.33	0.095	245.9	0.0204
425.37	0.095	245.9	0.0213
425.40	0.095	246	0.0213
425.43	0.096	246	0.0213
425.47	0.096	246	0.0213
425.50	0.096	246.1	0.0222
425.53	0.095	246.1	0.0222
425.57	0.095	246.1	0.0213
425.60	0.096	246.2	0.0222
425.65	0.097	246.2	0.0222
425.68	0.095	246.2	0.0231
425.70	0.095	246.2	0.0231
425.73	0.096	246.3	0.0231
425.77	0.096	246.2	0.0231
425.80	0.096	246.2	0.0231
425.83	0.096	246.3	0.0231
425.87	0.095	246.3	0.0231
425.90	0.094	246.3	0.0231
425.93	0.098	246.5	0.024
425.97	0.096	246.4	0.024
426.00	0.095	246.4	0.024
426.03	0.095	246.4	0.024
426.07	0.095	246.5	0.024
426.10	0.095	246.5	0.024
426.13	0.096	246.5	0.024
426.17	0.096	246.6	0.024
426.20	0.095	246.6	0.024
426.23	0.095	246.6	0.024
426.27	0.095	246.6	0.0249
426.30	0.095	246.6	0.0249
426.33	0.095	246.6	0.0249
426.37	0.095	246.6	0.0249
426.40	0.095	246.6	0.0249
426.43	0.092	246.6	0.024
426.47	0.097	246.8	0.024
426.50	0.095	246.8	0.0249
426.53	0.095	246.7	0.024
426.57	0.094	246.7	0.0249
426.60	0.094	246.7	0.0249
426.63	0.094	246.7	0.0249
426.67	0.094	246.8	0.0249
426.70	0.094	246.8	0.0249
426.73	0.093	246.8	0.0249
426.77	0.093	246.8	0.0249
426.80	0.093	246.8	0.0249
426.83	0.093	246.8	0.0249

Prova triassiale ciclica SNME01-C3			
pressione di confinamento (kPa)		380	
deviatore ciclico (kPa)		80	
frequenza (hz)		0.00071429	
tempo	cella di carico	u	LVDT
(min)	kN	(kPa)	δ (mm)
426.87	0.093	246.8	0.0249
426.90	0.092	246.8	0.0249
426.93	0.092	246.8	0.0249
426.97	0.092	246.8	0.0249
427.00	0.092	246.8	0.024
427.03	0.092	246.8	0.024
427.07	0.091	246.8	0.024
427.12	0.091	246.8	0.024
427.15	0.091	246.8	0.024
427.17	0.091	246.8	0.024
427.20	0.09	246.8	0.0231
427.23	0.089	246.8	0.024
427.27	0.089	246.8	0.024
427.30	0.085	246.8	0.024
427.33	0.085	246.7	0.024
427.37	0.088	246.9	0.024
427.40	0.093	247	0.0249
427.43	0.089	246.9	0.024
427.47	0.088	246.9	0.0231
427.50	0.087	246.8	0.0231
427.53	0.087	246.8	0.0231
427.57	0.087	246.8	0.0231
427.60	0.086	246.8	0.0231
427.63	0.086	246.8	0.0231
427.67	0.086	246.8	0.0222
427.70	0.085	246.8	0.0222
427.73	0.085	246.8	0.0222
427.77	0.084	246.8	0.0222
427.80	0.084	246.8	0.0213
427.83	0.084	246.7	0.0222
427.87	0.083	246.7	0.0213
427.90	0.082	246.7	0.0213
427.93	0.082	246.7	0.0213
427.97	0.082	246.7	0.0213
428.00	0.081	246.7	0.0213
428.03	0.081	246.7	0.0204
428.07	0.081	246.7	0.0204
428.10	0.08	246.6	0.0204
428.13	0.079	246.6	0.0195
428.17	0.079	246.6	0.0195
428.20	0.079	246.6	0.0195
428.23	0.078	246.6	0.0195
428.27	0.078	246.6	0.0195
428.30	0.078	246.6	0.0186
428.33	0.077	246.4	0.0178
428.37	0.075	246.5	0.0186
428.40	0.077	246.5	0.0186
428.43	0.075	246.5	0.0186
428.47	0.074	246.5	0.0178
428.50	0.074	246.4	0.0169
428.53	0.072	246.3	0.0169
428.58	0.074	246.4	0.0178
428.62	0.074	246.4	0.0169
428.63	0.071	246.3	0.0151
428.67	0.071	246.3	0.016
428.70	0.072	246.3	0.016
428.73	0.071	246.3	0.0151
428.77	0.069	246.2	0.0151

Prova triassiale ciclica SNME01-C3			
pressione di confinamento (kPa)		380	
deviatore ciclico (kPa)		80	
frequenza (hz)		0.00071429	
tempo	cella di carico	u	LVDT
(min)	kN	(kPa)	δ (mm)
428.80	0.068	246.2	0.0142
428.83	0.068	246.2	0.0142
428.87	0.069	246.2	0.0133
428.90	0.067	246.1	0.0133
428.93	0.066	246.1	0.0133
428.97	0.066	246.1	0.0124
429.00	0.065	246	0.0124
429.03	0.065	246	0.0115
429.07	0.065	246	0.0115
429.10	0.064	246	0.0107
429.13	0.062	245.9	0.0107
429.17	0.062	245.9	0.0098
429.20	0.061	245.8	0.0098
429.23	0.062	245.8	0.0098
429.27	0.061	245.8	0.0089
429.30	0.061	245.8	0.0089
429.33	0.06	245.7	0.008
429.37	0.059	245.6	0.0071
429.40	0.058	245.6	0.0071
429.43	0.058	245.6	0.0062
429.47	0.056	245.5	0.0062
429.50	0.056	245.5	0.0053
429.53	0.056	245.5	0.0044
429.57	0.055	245.4	0.0036
429.60	0.053	245.3	0.0036
429.63	0.053	245.3	0.0027
429.67	0.053	245.3	0.0027
429.70	0.049	245.1	0.0027
429.73	0.053	245.1	0.0009
429.77	0.053	245.2	0.0009
429.80	0.051	245.1	-0.0009
429.83	0.048	245	-0.0018
429.87	0.048	245	-0.0027
429.90	0.048	245	-0.0027
429.93	0.045	244.8	-0.0027
429.97	0.045	244.8	-0.0044
430.02	0.045	244.8	-0.0053
430.05	0.045	244.8	-0.0053
430.07	0.045	244.8	-0.0053
430.10	0.045	244.8	-0.0062
430.13	0.042	244.5	-0.008
430.17	0.041	244.6	-0.008
430.20	0.042	244.6	-0.0089
430.23	0.041	244.5	-0.0098
430.27	0.039	244.4	-0.0098
430.30	0.039	244.4	-0.0107
430.33	0.039	244.4	-0.0115
430.37	0.038	244.3	-0.0133
430.40	0.034	244.1	-0.0142
430.43	0.036	244.1	-0.0142
430.47	0.035	244.1	-0.016
430.50	0.033	244	-0.016
430.53	0.033	244	-0.0169
430.57	0.033	244	-0.0169
430.60	0.032	243.9	-0.0186
430.63	0.031	243.8	-0.0195
430.67	0.03	243.8	-0.0204
430.70	0.03	243.7	-0.0213

Prova triassiale ciclica SNME01-C3			
ensione di confinamento (kPa)		380	
deviatore ciclico (kPa)		80	
frequenza (hz)		0.00071429	
tempo	cella di carico	u	LVDT
(min)	kN	(kPa)	δ (mm)
430.73	0.029	243.6	-0.0213
430.77	0.027	243.6	-0.0222
430.80	0.027	243.6	-0.0231
430.83	0.027	243.5	-0.024
430.87	0.026	243.4	-0.0249
430.90	0.024	243.4	-0.0266
430.93	0.024	243.3	-0.0275
430.97	0.023	243.2	-0.0275
431.00	0.022	243.2	-0.0284
431.03	0.022	243.1	-0.0293
431.07	0.021	243.1	-0.0311
431.10	0.021	243	-0.032
431.13	0.019	242.9	-0.0328
431.17	0.019	242.8	-0.0346
431.20	0.017	242.8	-0.0346
431.23	0.016	242.8	-0.0355
431.27	0.016	242.7	-0.0364
431.30	0.016	242.7	-0.0373
431.33	0.013	242.5	-0.0391
431.37	0.015	242.5	-0.0399
431.40	0.013	242.4	-0.0417
431.43	0.011	242.3	-0.0417
431.48	0.011	242.2	-0.0435
431.52	0.01	242.2	-0.0444
431.53	0.01	242.1	-0.0444
431.57	0.008	242.1	-0.0462
431.60	0.008	242	-0.047
431.63	0.008	242	-0.0488
431.67	0.007	241.9	-0.0488
431.70	0.006	241.8	-0.0506
431.73	0.005	241.7	-0.0524
431.77	0.003	241.6	-0.0524
431.80	0.003	241.6	-0.0533
431.83	0.003	241.5	-0.0541
431.87	0.002	241.4	-0.0559
431.90	0.001	241.3	-0.0586
431.93	0	241.2	-0.0604
431.97	-0.001	241.2	-0.063
432.00	-0.002	241	-0.063
432.03	-0.003	241	-0.0639
432.07	-0.003	241	-0.0657
432.10	-0.004	240.9	-0.0675
432.13	-0.005	240.8	-0.0692
432.17	-0.006	240.7	-0.071
432.20	-0.006	240.6	-0.0728
432.23	-0.007	240.5	-0.0728
432.27	-0.009	240.5	-0.0754
432.30	-0.009	240.4	-0.0781
432.33	-0.009	240.3	-0.0808
432.37	-0.011	240.1	-0.0843
432.40	-0.011	240.1	-0.0879
432.43	-0.012	240	-0.0914
432.47	-0.014	239.8	-0.0914
432.50	-0.014	239.8	-0.0959
432.53	-0.014	239.7	-0.1003
432.57	-0.015	239.6	-0.1056
432.60	-0.016	239.5	-0.1127
432.63	-0.017	239.3	-0.1198

Prova triassiale ciclica SNME01-C3			
pressione di confinamento (kPa)		380	
deviatore ciclico (kPa)		80	
frequenza (hz)		0.00071429	
tempo	cella di carico	u	LVDT
(min)	kN	(kPa)	δ (mm)
432.67	-0.017	239.2	-0.1278
432.70	-0.019	239	-0.1278
432.73	-0.019	239	-0.1394
432.77	-0.019	238.9	-0.1527
432.80	-0.02	238.7	-0.166
432.83	-0.022	238.4	-0.1784
432.87	-0.022	238.3	-0.1855
432.92	-0.023	238.2	-0.1917
432.95	-0.023	238	-0.1962
432.97	-0.024	237.9	-0.2006
433.00	-0.025	237.8	-0.205
433.03	-0.027	237.6	-0.205
433.07	-0.028	237.6	-0.2095
433.10	-0.028	237.4	-0.213
433.13	-0.028	237.3	-0.2166
433.17	-0.029	237.1	-0.2201
433.20	-0.03	237	-0.2228
433.23	-0.03	236.9	-0.2255
433.27	-0.032	236.8	-0.2255
433.30	-0.032	236.8	-0.229
433.33	-0.032	236.6	-0.2317
433.37	-0.033	236.5	-0.2352
433.40	-0.034	236.4	-0.2379
433.43	-0.035	236.3	-0.2397
433.47	-0.036	236.1	-0.2423
433.50	-0.037	236	-0.2423
433.53	-0.038	236	-0.245
433.57	-0.038	235.9	-0.2468
433.60	-0.038	235.8	-0.2485
433.63	-0.039	235.7	-0.2503
433.67	-0.041	235.5	-0.2512
433.70	-0.04	235.4	-0.2548
433.73	-0.041	235.3	-0.2548
433.77	-0.043	235.3	-0.2583
433.80	-0.043	235.1	-0.2601
433.83	-0.043	235	-0.2627
433.87	-0.044	234.9	-0.2636
433.90	-0.045	234.8	-0.2654
433.93	-0.045	234.7	-0.2672
433.97	-0.046	234.5	-0.2672
434.00	-0.047	234.5	-0.2698
434.03	-0.047	234.5	-0.2716
434.07	-0.047	234.3	-0.2734
434.10	-0.048	234.2	-0.2752
434.13	-0.05	234.1	-0.2769
434.17	-0.05	234.1	-0.2787
434.20	-0.051	234	-0.2787
434.23	-0.052	234	-0.2805
434.27	-0.052	233.8	-0.2823
434.30	-0.052	233.7	-0.2832
434.33	-0.053	233.6	-0.2858
434.38	-0.054	233.5	-0.2867
434.42	-0.053	233.4	-0.2885
434.43	-0.055	233.3	-0.2903
434.47	-0.056	233.2	-0.292
434.50	-0.056	233	-0.2929
434.53	-0.057	232.9	-0.2929
434.57	-0.057	232.9	-0.2947

Prova triassiale ciclica SNME01-C3			
pressione di confinamento (kPa)		380	
deviatore ciclico (kPa)		80	
frequenza (hz)		0.00071429	
tempo	cella di carico	u	LVDT
(min)	kN	(kPa)	δ (mm)
434.60	-0.057	232.9	-0.2965
434.63	-0.058	232.8	-0.2974
434.67	-0.059	232.6	-0.2982
434.70	-0.059	232.6	-0.3
434.73	-0.06	232.5	-0.3009
434.77	-0.062	232.3	-0.3009
434.80	-0.062	232.3	-0.3027
434.83	-0.062	232.3	-0.3036
434.87	-0.062	232.2	-0.3053
434.90	-0.062	232.1	-0.3062
434.93	-0.064	231.9	-0.3071
434.97	-0.063	231.9	-0.308
435.00	-0.064	231.8	-0.308
435.03	-0.065	231.8	-0.3089
435.07	-0.065	231.7	-0.3107
435.10	-0.066	231.5	-0.3124
435.13	-0.066	231.5	-0.3133
435.17	-0.067	231.4	-0.3151
435.20	-0.067	231.3	-0.3151
435.23	-0.068	231.2	-0.3151
435.27	-0.068	231.2	-0.316
435.30	-0.068	231.1	-0.3169
435.33	-0.069	231	-0.3178
435.37	-0.07	230.9	-0.3196
435.40	-0.07	230.8	-0.3204
435.43	-0.071	230.8	-0.3213
435.47	-0.071	230.7	-0.3213
435.50	-0.071	230.7	-0.3222
435.53	-0.071	230.6	-0.3222
435.57	-0.072	230.5	-0.324
435.60	-0.072	230.4	-0.3249
435.63	-0.074	230.3	-0.3258
435.67	-0.073	230.3	-0.3258
435.70	-0.073	230.2	-0.3258
435.73	-0.074	230.2	-0.3267
435.77	-0.074	230.1	-0.3275
435.80	-0.075	230	-0.3284
435.85	-0.075	229.9	-0.3293
435.87	-0.075	229.9	-0.3302
435.90	-0.075	229.8	-0.3302
435.93	-0.076	229.7	-0.332
435.97	-0.077	229.6	-0.332
436.00	-0.077	229.6	-0.3329
436.03	-0.077	229.5	-0.3329
436.07	-0.078	229.4	-0.3329
436.10	-0.078	229.4	-0.3338
436.13	-0.078	229.4	-0.3346
436.17	-0.078	229.3	-0.3346
436.20	-0.079	229.2	-0.3355
436.23	-0.078	229.2	-0.3364
436.27	-0.079	229.1	-0.3364
436.30	-0.08	229	-0.3373
436.33	-0.08	229	-0.3373
436.37	-0.08	229	-0.3382
436.40	-0.08	229	-0.3382
436.43	-0.08	228.9	-0.3391
436.47	-0.081	228.8	-0.3391
436.50	-0.081	228.8	-0.3391

Prova triassiale ciclica SNME01-C3			
pressione di confinamento (kPa)		380	
deviatore ciclico (kPa)		80	
frequenza (hz)		0.00071429	
tempo	cella di carico	u	LVDT
(min)	kN	(kPa)	δ (mm)
436.53	-0.081	228.7	-0.34
436.57	-0.081	228.7	-0.34
436.60	-0.081	228.6	-0.3409
436.63	-0.082	228.6	-0.3409
436.67	-0.082	228.5	-0.3417
436.70	-0.082	228.5	-0.3417
436.73	-0.082	228.5	-0.3417
436.77	-0.083	228.4	-0.3426
436.80	-0.083	228.4	-0.3426
436.83	-0.082	228.4	-0.3426
436.87	-0.082	228.3	-0.3426
436.90	-0.083	228.2	-0.3435
436.93	-0.083	228.2	-0.3435
436.97	-0.083	228.2	-0.3435
437.00	-0.083	228.1	-0.3444
437.03	-0.083	228.1	-0.3444
437.07	-0.083	228.1	-0.3444
437.10	-0.084	228	-0.3453
437.13	-0.084	228	-0.3453
437.17	-0.084	228	-0.3453
437.20	-0.084	227.9	-0.3453
437.23	-0.084	227.9	-0.3462
437.28	-0.084	227.9	-0.3462
437.32	-0.084	227.8	-0.3462
437.33	-0.084	227.8	-0.3462
437.37	-0.084	227.8	-0.3462
437.40	-0.084	227.8	-0.3471
437.43	-0.084	227.7	-0.3471
437.47	-0.084	227.7	-0.3471
437.50	-0.084	227.7	-0.3471
437.53	-0.084	227.7	-0.3471
437.57	-0.084	227.7	-0.3471
437.60	-0.084	227.7	-0.3471
437.63	-0.084	227.6	-0.3471
437.67	-0.084	227.6	-0.348
437.70	-0.084	227.6	-0.348
437.73	-0.084	227.6	-0.348
437.77	-0.084	227.5	-0.348
437.80	-0.084	227.5	-0.348
437.83	-0.084	227.5	-0.348
437.87	-0.084	227.5	-0.348
437.90	-0.084	227.5	-0.348
437.93	-0.084	227.5	-0.348
437.97	-0.083	227.5	-0.348
438.00	-0.083	227.4	-0.348
438.03	-0.083	227.4	-0.348
438.07	-0.083	227.4	-0.348
438.10	-0.083	227.4	-0.348
438.13	-0.083	227.4	-0.348
438.17	-0.083	227.4	-0.348
438.20	-0.083	227.4	-0.348
438.23	-0.083	227.4	-0.348
438.27	-0.083	227.4	-0.348
438.30	-0.083	227.4	-0.348
438.33	-0.082	227.4	-0.348
438.37	-0.082	227.4	-0.348
438.40	-0.082	227.4	-0.348
438.43	-0.082	227.4	-0.348

Prova triassiale ciclica SNME01-C3			
pressione di confinamento (kPa)		380	
deviatore ciclico (kPa)		80	
frequenza (hz)		0.00071429	
tempo	cella di carico	u	LVDT
(min)	kN	(kPa)	δ (mm)
438.47	-0.081	227.4	-0.348
438.50	-0.081	227.4	-0.348
438.53	-0.081	227.4	-0.348
438.57	-0.081	227.4	-0.348
438.60	-0.081	227.4	-0.348
438.63	-0.08	227.4	-0.3471
438.67	-0.08	227.4	-0.3471
438.70	-0.079	227.4	-0.3471
438.75	-0.079	227.4	-0.3471
438.78	-0.079	227.4	-0.3471
438.80	-0.079	227.4	-0.3471
438.83	-0.079	227.4	-0.3471
438.87	-0.079	227.4	-0.3471
438.90	-0.079	227.4	-0.3471
438.93	-0.078	227.4	-0.3462
438.97	-0.078	227.4	-0.3462
439.00	-0.077	227.5	-0.3462
439.03	-0.077	227.5	-0.3462
439.07	-0.076	227.5	-0.3462
439.10	-0.076	227.5	-0.3462
439.13	-0.076	227.5	-0.3453
439.17	-0.076	227.5	-0.3453
439.20	-0.076	227.5	-0.3453
439.23	-0.076	227.5	-0.3444
439.27	-0.074	227.6	-0.3444
439.30	-0.074	227.6	-0.3444
439.33	-0.074	227.6	-0.3444
439.37	-0.074	227.6	-0.3444
439.40	-0.073	227.7	-0.3435
439.43	-0.073	227.7	-0.3435
439.47	-0.072	227.7	-0.3435
439.50	-0.072	227.7	-0.3435
439.53	-0.071	227.7	-0.3426
439.57	-0.071	227.7	-0.3426
439.60	-0.071	227.7	-0.3426
439.63	-0.071	227.8	-0.3417
439.67	-0.069	227.8	-0.3409
439.70	-0.069	227.9	-0.3409
439.73	-0.068	227.9	-0.3409
439.77	-0.068	227.9	-0.3409
439.80	-0.068	227.9	-0.34
439.83	-0.067	228	-0.34
439.87	-0.067	228	-0.3391
439.90	-0.066	228	-0.3391
439.93	-0.066	228.1	-0.3382
439.97	-0.065	228.1	-0.3382
440.00	-0.065	228.2	-0.3382
440.03	-0.065	228.2	-0.3373
440.07	-0.065	228.2	-0.3373
440.10	-0.064	228.2	-0.3364
440.13	-0.063	228.3	-0.3364
440.18	-0.063	228.3	-0.3355
440.22	-0.062	228.4	-0.3355
440.23	-0.062	228.4	-0.3346
440.27	-0.061	228.5	-0.3338
440.30	-0.06	228.5	-0.3338
440.33	-0.059	228.6	-0.3329
440.37	-0.059	228.6	-0.3329

Prova triassiale ciclica SNME01-C3			
pressione di confinamento (kPa)		380	
deviatore ciclico (kPa)		80	
frequenza (hz)		0.00071429	
tempo	cella di carico	u	LVDT
(min)	kN	(kPa)	δ (mm)
440.40	-0.059	228.6	-0.332
440.43	-0.058	228.7	-0.3311
440.47	-0.057	228.7	-0.3311
440.50	-0.057	228.8	-0.3302
440.53	-0.056	228.9	-0.3302
440.57	-0.055	228.9	-0.3293
440.60	-0.055	228.9	-0.3284
440.63	-0.055	229	-0.3275
440.67	-0.054	229.1	-0.3267
440.70	-0.053	229.1	-0.3258
440.73	-0.053	229.1	-0.3258
440.77	-0.052	229.2	-0.3258
440.80	-0.051	229.3	-0.3249
440.83	-0.051	229.3	-0.324
440.87	-0.051	229.3	-0.3231
440.90	-0.05	229.4	-0.3231
440.93	-0.05	229.4	-0.3222
440.97	-0.048	229.6	-0.3204
441.00	-0.048	229.6	-0.3204
441.03	-0.047	229.7	-0.3196
441.07	-0.047	229.7	-0.3187
441.10	-0.046	229.7	-0.3178
441.13	-0.045	229.8	-0.3169
441.17	-0.044	229.9	-0.316
441.20	-0.044	229.9	-0.3151
441.23	-0.043	230.1	-0.3151
441.27	-0.041	230.2	-0.3142
441.30	-0.041	230.2	-0.3124
441.33	-0.041	230.2	-0.3124
441.37	-0.041	230.3	-0.3116
441.40	-0.04	230.3	-0.3098
441.43	-0.039	230.4	-0.3089
441.47	-0.038	230.5	-0.3089
441.50	-0.037	230.6	-0.3071
441.53	-0.037	230.6	-0.3062
441.57	-0.037	230.7	-0.3045
441.60	-0.035	230.8	-0.3036
441.65	-0.035	230.9	-0.3027
441.68	-0.035	230.9	-0.3009
441.70	-0.033	231	-0.2991
441.73	-0.033	231.1	-0.2982
441.77	-0.031	231.2	-0.2965
441.80	-0.031	231.3	-0.2965
441.83	-0.03	231.4	-0.2956
441.87	-0.03	231.4	-0.2938
441.90	-0.03	231.5	-0.2929
441.93	-0.028	231.5	-0.2911
441.97	-0.027	231.6	-0.2894
442.00	-0.027	231.7	-0.2876
442.03	-0.026	231.8	-0.2876
442.07	-0.025	231.9	-0.2858
442.10	-0.025	231.9	-0.2832
442.13	-0.024	232.1	-0.2823
442.17	-0.023	232.1	-0.2805
442.20	-0.022	232.2	-0.2787
442.23	-0.021	232.4	-0.2743
442.27	-0.02	232.5	-0.2743
442.30	-0.02	232.5	-0.2725

Prova triassiale ciclica SNME01-C3			
pressione di confinamento (kPa)		380	
deviatore ciclico (kPa)		80	
frequenza (hz)		0.00071429	
tempo	cella di carico	u	LVDT
(min)	kN	(kPa)	δ (mm)
442.33	-0.02	232.5	-0.2716
442.37	-0.019	232.7	-0.2681
442.40	-0.018	232.8	-0.2663
442.43	-0.016	232.9	-0.2645
442.47	-0.016	233	-0.2619
442.50	-0.014	233.2	-0.2619
442.53	-0.014	233.3	-0.2592
442.57	-0.014	233.3	-0.2565
442.60	-0.014	233.3	-0.2556
442.63	-0.012	233.5	-0.2521
442.67	-0.011	233.6	-0.2494
442.70	-0.01	233.7	-0.2459
442.73	-0.009	233.8	-0.2459
442.77	-0.008	233.9	-0.2432
442.80	-0.008	233.9	-0.2406
442.83	-0.007	234	-0.237
442.87	-0.007	234.1	-0.2343
442.90	-0.006	234.2	-0.2308
442.93	-0.005	234.4	-0.2263
442.97	-0.003	234.5	-0.2263
443.00	-0.002	234.6	-0.2219
443.03	-0.002	234.6	-0.2184
443.08	-0.002	234.8	-0.2139
443.12	0.001	235	-0.2113
443.13	0.001	235	-0.205
443.17	0.001	235.1	-0.2024
443.20	0	235.1	-0.2006
443.23	0.003	235.3	-0.1935
443.27	0.003	235.4	-0.19
443.30	0.005	235.7	-0.19
443.33	0.004	235.7	-0.1829
443.37	0.004	235.7	-0.1793
443.40	0.008	235.9	-0.1713
443.43	0.009	236	-0.1687
443.47	0.006	236	-0.166
443.50	0.008	236.2	-0.1624
443.53	0.011	236.5	-0.1553
443.57	0.013	236.6	-0.1553
443.60	0.013	236.6	-0.1491
443.63	0.011	236.6	-0.1456
443.67	0.011	236.7	-0.1429
443.70	0.014	236.8	-0.1376
443.73	0.014	236.9	-0.1323
443.77	0.015	237.1	-0.1323
443.80	0.019	237.3	-0.126
443.83	0.019	237.3	-0.1207
443.87	0.016	237.3	-0.1181
443.90	0.017	237.4	-0.1145
443.93	0.02	237.6	-0.1101
443.97	0.021	237.8	-0.1047
444.00	0.02	237.8	-0.1012
444.03	0.022	238	-0.1012
444.07	0.022	238	-0.0968
444.10	0.024	238.1	-0.0923
444.13	0.023	238.1	-0.0897
444.17	0.025	238.3	-0.087
444.20	0.025	238.3	-0.0852
444.23	0.026	238.4	-0.0826

Prova triassiale ciclica SNME01-C3			
pressione di confinamento (kPa)		380	
deviatore ciclico (kPa)		80	
frequenza (hz)		0.00071429	
tempo	cella di carico	u	LVDT
(min)	kN	(kPa)	δ (mm)
444.27	0.027	238.5	-0.0826
444.30	0.027	238.5	-0.0808
444.33	0.029	238.6	-0.0781
444.37	0.03	238.7	-0.0763
444.40	0.03	238.8	-0.0754
444.43	0.031	238.9	-0.0737
444.47	0.032	239	-0.0719
444.50	0.033	239	-0.0719
444.55	0.034	239.1	-0.0692
444.58	0.034	239.1	-0.0683
444.60	0.036	239.3	-0.0683
444.63	0.036	239.3	-0.0666
444.67	0.036	239.3	-0.0657
444.70	0.038	239.4	-0.0648
444.73	0.038	239.5	-0.0639
444.77	0.039	239.5	-0.0621
444.80	0.04	239.7	-0.0604
444.83	0.041	239.7	-0.0604
444.87	0.041	239.7	-0.0595
444.90	0.042	239.8	-0.0568
444.93	0.045	240	-0.055
444.97	0.042	239.9	-0.055
445.00	0.043	240	-0.0533
445.03	0.045	240.1	-0.0524
445.07	0.046	240.2	-0.0524
445.10	0.046	240.2	-0.0515
445.13	0.047	240.3	-0.0497
445.17	0.048	240.4	-0.0488
445.20	0.049	240.4	-0.0479
445.23	0.049	240.5	-0.0462
445.27	0.049	240.6	-0.0453
445.30	0.052	240.7	-0.0453
445.33	0.052	240.7	-0.0444
445.37	0.052	240.8	-0.0426
445.40	0.052	240.8	-0.0417
445.43	0.053	240.9	-0.0408
445.47	0.054	241	-0.0391
445.50	0.055	241.1	-0.0382
445.53	0.056	241.2	-0.0382
445.57	0.056	241.2	-0.0373
445.60	0.056	241.3	-0.0355
445.63	0.058	241.3	-0.0346
445.67	0.059	241.5	-0.0337
445.70	0.056	241.4	-0.0328
445.73	0.059	241.6	-0.032
445.77	0.061	241.7	-0.032
445.80	0.061	241.7	-0.0302
445.83	0.061	241.8	-0.0293
445.87	0.062	241.8	-0.0284
445.90	0.063	241.9	-0.0275
445.93	0.063	242	-0.0266
445.97	0.063	242.1	-0.0257
446.02	0.064	242.1	-0.0249
446.03	0.064	242.2	-0.024
446.07	0.066	242.3	-0.0222
446.10	0.067	242.4	-0.0222
446.13	0.068	242.4	-0.0213
446.17	0.068	242.4	-0.0204

Prova triassiale ciclica SNME01-C3			
pressione di confinamento (kPa)		380	
deviatore ciclico (kPa)		80	
frequenza (hz)		0.00071429	
tempo	cella di carico	u	LVDT
(min)	kN	(kPa)	δ (mm)
446.20	0.068	242.5	-0.0195
446.23	0.068	242.6	-0.0186
446.27	0.069	242.6	-0.0178
446.30	0.07	242.7	-0.0169
446.33	0.071	242.8	-0.0169
446.37	0.071	242.8	-0.016
446.40	0.071	242.8	-0.0151
446.43	0.072	242.9	-0.0142
446.47	0.075	243	-0.0124
446.50	0.073	243.1	-0.0115
446.53	0.072	243.1	-0.0115
446.57	0.074	243.2	-0.0115
446.60	0.076	243.2	-0.0098
446.63	0.076	243.3	-0.0098
446.67	0.074	243.3	-0.0089
446.70	0.076	243.4	-0.008
446.73	0.078	243.5	-0.0062
446.77	0.075	243.5	-0.0071
446.80	0.077	243.6	-0.0071
446.83	0.078	243.6	-0.0053
446.87	0.078	243.7	-0.0044
446.90	0.081	243.8	-0.0027
446.93	0.081	243.8	-0.0027
446.97	0.078	243.8	-0.0027
447.00	0.079	243.9	-0.0018
447.03	0.082	244	-0.0018
447.07	0.082	244	-0.0009
447.10	0.082	244.1	0
447.13	0.081	244.1	0
447.17	0.082	244.2	0.0009
447.20	0.083	244.3	0.0018
447.23	0.084	244.4	0.0027
447.27	0.085	244.4	0.0027
447.30	0.085	244.4	0.0036
447.33	0.084	244.5	0.0036
447.37	0.085	244.5	0.0044
447.40	0.086	244.6	0.0053
447.45	0.086	244.7	0.0062
447.48	0.086	244.7	0.0062
447.50	0.087	244.8	0.0071
447.53	0.087	244.8	0.0071
447.57	0.087	244.9	0.008
447.60	0.088	245	0.008
447.63	0.089	245	0.0089
447.67	0.089	245	0.0098
447.70	0.088	245.1	0.0098
447.73	0.089	245.1	0.0098
447.77	0.089	245.2	0.0107
447.80	0.09	245.2	0.0115
447.83	0.09	245.3	0.0115
447.87	0.091	245.3	0.0115
447.90	0.091	245.3	0.0124
447.93	0.09	245.3	0.0124
447.97	0.091	245.4	0.0133
448.00	0.091	245.5	0.0133
448.03	0.091	245.5	0.0142
448.07	0.092	245.6	0.0142
448.10	0.092	245.6	0.0142

Prova triassiale ciclica SNME01-C3			
pressione di confinamento (kPa)		380	
deviatore ciclico (kPa)		80	
frequenza (hz)		0.00071429	
tempo	cella di carico	u	LVDT
(min)	kN	(kPa)	δ (mm)
448.13	0.092	245.6	0.0151
448.17	0.093	245.7	0.0151
448.20	0.093	245.7	0.0151
448.23	0.092	245.8	0.016
448.27	0.094	245.9	0.016
448.30	0.093	245.9	0.016
448.33	0.093	245.9	0.0169
448.37	0.093	245.9	0.0169
448.40	0.094	246	0.0169
448.43	0.094	246	0.0178
448.47	0.094	246.1	0.0178
448.50	0.094	246.1	0.0186
448.53	0.097	246.2	0.0186
448.57	0.093	246.2	0.0186
448.60	0.093	246.1	0.0186
448.63	0.097	246.3	0.0195
448.67	0.096	246.3	0.0195
448.70	0.096	246.3	0.0195
448.73	0.095	246.4	0.0204
448.77	0.093	246.3	0.0204
448.80	0.097	246.3	0.0195
448.83	0.097	246.5	0.0204
448.87	0.093	246.4	0.0195
448.92	0.095	246.4	0.0204
448.95	0.095	246.5	0.0213
448.97	0.098	246.6	0.0213
449.00	0.096	246.6	0.0213
449.03	0.094	246.5	0.0213
449.07	0.098	246.7	0.0222
449.10	0.095	246.6	0.0222
449.13	0.095	246.6	0.0213
449.17	0.095	246.7	0.0222
449.20	0.098	246.8	0.0222
449.23	0.094	246.7	0.0222
449.27	0.096	246.8	0.0222
449.30	0.096	246.8	0.0231
449.33	0.098	246.9	0.0231
449.37	0.094	246.9	0.0222
449.40	0.094	246.8	0.0222
449.43	0.095	246.9	0.0222
449.47	0.096	246.9	0.0231
449.50	0.096	246.9	0.0231
449.53	0.095	246.9	0.0231
449.57	0.095	246.9	0.0231
449.60	0.095	246.9	0.0231
449.63	0.095	247	0.0231
449.67	0.095	247	0.0231
449.70	0.095	247	0.0231
449.73	0.095	247	0.0231
449.77	0.095	247	0.0231
449.80	0.095	247.1	0.0231
449.83	0.095	247.1	0.0231
449.87	0.095	247.1	0.0231
449.90	0.094	247.1	0.0231
449.93	0.094	247.1	0.0231
449.97	0.094	247.1	0.0231
450.00	0.094	247.2	0.0231
450.03	0.094	247.2	0.0231

Prova triassiale ciclica SNME01-C3			
pressione di confinamento (kPa)		380	
deviatore ciclico (kPa)		80	
frequenza (hz)		0.00071429	
tempo	cella di carico	u	LVDT
(min)	kN	(kPa)	δ (mm)
450.07	0.093	247.2	0.0231
450.10	0.093	247.2	0.0231
450.13	0.093	247.2	0.0231
450.17	0.094	247.2	0.0231
450.20	0.092	247.2	0.0231
450.23	0.092	247.2	0.0231
450.27	0.092	247.2	0.0231
450.30	0.092	247.2	0.0231
450.35	0.092	247.2	0.0231
450.38	0.092	247.2	0.0231
450.40	0.091	247.2	0.0231
450.43	0.091	247.2	0.0222
450.47	0.091	247.2	0.0222
450.50	0.091	247.3	0.0222
450.53	0.09	247.2	0.0222
450.57	0.09	247.2	0.0222
450.60	0.09	247.3	0.0222
450.63	0.089	247.3	0.0222
450.67	0.089	247.3	0.0222
450.70	0.089	247.3	0.0222
450.73	0.088	247.2	0.0213
450.77	0.088	247.2	0.0213
450.80	0.088	247.2	0.0213
450.83	0.087	247.2	0.0213
450.87	0.087	247.2	0.0213
450.90	0.087	247.2	0.0213
450.93	0.087	247.2	0.0213
450.97	0.086	247.2	0.0213
451.00	0.085	247.2	0.0204
451.03	0.085	247.2	0.0204
451.07	0.085	247.2	0.0204
451.10	0.084	247.2	0.0204
451.13	0.084	247.2	0.0204
451.17	0.084	247.1	0.0204
451.20	0.083	247.1	0.0195
451.23	0.083	247.1	0.0195
451.27	0.082	247.1	0.0195
451.30	0.082	247.1	0.0195
451.33	0.081	247.1	0.0195
451.37	0.081	247	0.0195
451.40	0.081	247	0.0186
451.43	0.08	247	0.0186
451.47	0.08	247	0.0186
451.50	0.079	247	0.0178
451.53	0.078	246.9	0.0178
451.57	0.078	246.9	0.0178
451.60	0.078	246.9	0.0178
451.63	0.078	246.9	0.0178
451.67	0.077	246.9	0.0169
451.70	0.076	246.9	0.0169
451.73	0.076	246.8	0.016
451.77	0.074	246.8	0.016
451.82	0.074	246.8	0.016
451.85	0.074	246.8	0.0151
451.87	0.073	246.7	0.0151
451.90	0.073	246.7	0.0151
451.93	0.073	246.7	0.0151
451.97	0.072	246.7	0.0142

Prova triassiale ciclica SNME01-C3			
ensione di confinamento (kPa)		380	
deviatore ciclico (kPa)		80	
frequenza (hz)		0.00071429	
tempo	cella di carico	u	LVDT
(min)	kN	(kPa)	δ (mm)
452.00	0.072	246.7	0.0142
452.03	0.071	246.6	0.0133
452.07	0.07	246.6	0.0133
452.10	0.069	246.6	0.0133
452.13	0.069	246.6	0.0124
452.17	0.069	246.5	0.0124
452.20	0.068	246.5	0.0124
452.23	0.067	246.5	0.0115
452.27	0.067	246.5	0.0115
452.30	0.066	246.4	0.0107
452.33	0.066	246.4	0.0107
452.37	0.064	246.4	0.0107
452.40	0.064	246.3	0.0098
452.43	0.064	246.3	0.0098
452.47	0.063	246.3	0.0089
452.50	0.062	246.2	0.008
452.53	0.062	246.2	0.008
452.57	0.061	246.2	0.008
452.60	0.06	246.2	0.0071
452.63	0.06	246.1	0.0071
452.67	0.06	246.1	0.0062
452.70	0.059	246	0.0053
452.73	0.058	246	0.0044
452.77	0.057	245.9	0.0044
452.80	0.056	245.9	0.0044
452.83	0.056	245.9	0.0036
452.87	0.056	245.9	0.0027
452.90	0.055	245.8	0.0027
452.93	0.053	245.8	0.0018
452.97	0.054	245.7	0.0009
453.00	0.053	245.6	0
453.03	0.051	245.6	0
453.07	0.051	245.6	-0.0009
453.10	0.051	245.5	-0.0009
453.13	0.05	245.5	-0.0018
453.17	0.049	245.4	-0.0027
453.20	0.048	245.4	-0.0036
453.25	0.047	245.3	-0.0044
453.28	0.047	245.3	-0.0044
453.30	0.047	245.2	-0.0053
453.33	0.046	245.2	-0.0062
453.37	0.044	245.1	-0.0062
453.40	0.044	245.1	-0.0071
453.43	0.044	245.1	-0.008
453.47	0.042	245	-0.0089
453.50	0.042	245	-0.0098
453.53	0.041	244.9	-0.0107
453.57	0.041	244.8	-0.0115
453.60	0.038	244.8	-0.0115
453.63	0.038	244.8	-0.0124
453.67	0.038	244.7	-0.0133
453.70	0.038	244.7	-0.0142
453.73	0.036	244.6	-0.0151
453.77	0.037	244.6	-0.016
453.80	0.035	244.5	-0.0169
453.83	0.033	244.4	-0.0169
453.87	0.033	244.4	-0.0186
453.90	0.033	244.3	-0.0195

Prova triassiale ciclica SNME01-C3			
ensione di confinamento (kPa)		380	
deviatore ciclico (kPa)		80	
frequenza (hz)		0.00071429	
tempo	cella di carico	u	LVDT
(min)	kN	(kPa)	δ (mm)
453.93	0.033	244.3	-0.0195
453.97	0.031	244.2	-0.0213
454.00	0.03	244.1	-0.0222
454.03	0.03	244.1	-0.0231
454.07	0.027	244	-0.0231
454.10	0.028	244	-0.024
454.13	0.028	243.9	-0.0249
454.17	0.027	243.8	-0.0266
454.20	0.025	243.8	-0.0275
454.23	0.025	243.7	-0.0284
454.27	0.024	243.6	-0.0302
454.30	0.023	243.5	-0.0302
454.33	0.022	243.5	-0.0311
454.37	0.022	243.5	-0.032
454.40	0.021	243.4	-0.0328
454.43	0.02	243.3	-0.0346
454.47	0.019	243.3	-0.0355
454.50	0.019	243.2	-0.0364
454.53	0.017	243.1	-0.0364
454.57	0.018	243.1	-0.0373
454.60	0.018	243.1	-0.0391
454.63	0.016	243	-0.0399
454.67	0.014	242.8	-0.0417
454.72	0.014	242.8	-0.0426
454.75	0.013	242.7	-0.0444
454.77	0.012	242.7	-0.0453
454.80	0.01	242.6	-0.047
454.83	0.011	242.6	-0.0479
454.87	0.01	242.5	-0.0479
454.90	0.009	242.5	-0.0488
454.93	0.009	242.4	-0.0506
454.97	0.007	242.3	-0.0524
455.00	0.006	242.2	-0.0533
455.03	0.006	242.1	-0.055
455.07	0.005	242.1	-0.0559
455.10	0.003	241.9	-0.0559
455.13	0.003	241.9	-0.0586
455.17	0.003	241.9	-0.0595
455.20	0.002	241.8	-0.0612
455.23	0.001	241.7	-0.063
455.27	0	241.6	-0.0648
455.30	-0.001	241.5	-0.0657
455.33	-0.002	241.4	-0.0657
455.37	-0.003	241.4	-0.0675
455.40	-0.003	241.3	-0.0692
455.43	-0.004	241.2	-0.0701
455.47	-0.005	241.2	-0.0719
455.50	-0.006	241.1	-0.0737
455.53	-0.006	241	-0.0754
455.57	-0.008	240.9	-0.0754
455.60	-0.009	240.9	-0.079
455.63	-0.009	240.8	-0.0808
455.67	-0.01	240.6	-0.0843
455.70	-0.01	240.6	-0.087
455.73	-0.011	240.4	-0.0914
455.77	-0.012	240.3	-0.095
455.80	-0.013	240.2	-0.095
455.83	-0.014	240.2	-0.1003

Prova triassiale ciclica SNME01-C3			
pressione di confinamento (kPa)		380	
deviatore ciclico (kPa)		80	
frequenza (hz)		0.00071429	
tempo	cella di carico	u	LVDT
(min)	kN	(kPa)	δ (mm)
455.87	-0.014	240.1	-0.1056
455.90	-0.014	239.9	-0.1127
455.93	-0.016	239.8	-0.1207
455.97	-0.017	239.6	-0.1314
456.00	-0.017	239.5	-0.1429
456.03	-0.019	239.3	-0.1429
456.07	-0.019	239.3	-0.158
456.10	-0.019	239.1	-0.1695
456.13	-0.02	238.9	-0.1793
456.18	-0.022	238.7	-0.1882
456.22	-0.022	238.6	-0.1935
456.23	-0.023	238.4	-0.1979
456.27	-0.024	238.3	-0.2015
456.30	-0.025	238.2	-0.2042
456.33	-0.025	238	-0.2086
456.37	-0.027	237.9	-0.2086
456.40	-0.027	237.9	-0.2121
456.43	-0.027	237.8	-0.2157
456.47	-0.028	237.7	-0.2184
456.50	-0.029	237.5	-0.221
456.53	-0.03	237.4	-0.2237
456.57	-0.031	237.3	-0.2255
456.60	-0.032	237.2	-0.2255
456.63	-0.032	237.2	-0.2263
456.67	-0.032	237	-0.2317
456.70	-0.033	236.9	-0.2343
456.73	-0.035	236.7	-0.2388
456.77	-0.035	236.6	-0.2414
456.80	-0.036	236.5	-0.2441
456.83	-0.036	236.4	-0.2441
456.87	-0.037	236.4	-0.2459
456.90	-0.037	236.3	-0.2485
456.93	-0.038	236.1	-0.2512
456.97	-0.04	235.9	-0.2539
457.00	-0.04	235.9	-0.2565
457.03	-0.041	235.8	-0.2583
457.07	-0.042	235.6	-0.2583
457.10	-0.043	235.6	-0.2601
457.13	-0.043	235.5	-0.2619
457.17	-0.043	235.4	-0.2627
457.20	-0.044	235.3	-0.2645
457.23	-0.044	235.2	-0.2672
457.27	-0.045	235.1	-0.2698
457.30	-0.046	234.9	-0.2698
457.33	-0.047	234.9	-0.2725
457.37	-0.047	234.8	-0.2734
457.40	-0.048	234.7	-0.2752
457.43	-0.048	234.6	-0.2769
457.47	-0.049	234.5	-0.2787
457.50	-0.05	234.3	-0.2805
457.53	-0.051	234.2	-0.2805
457.57	-0.051	234.2	-0.2823
457.62	-0.052	234.1	-0.2858
457.65	-0.052	234	-0.2858
457.67	-0.053	234	-0.2867
457.70	-0.053	233.9	-0.2885
457.73	-0.054	233.8	-0.2903
457.77	-0.055	233.6	-0.292

Prova triassiale ciclica SNME01-C3			
pressione di confinamento (kPa)		380	
deviatore ciclico (kPa)		80	
frequenza (hz)		0.00071429	
tempo	cella di carico	u	LVDT
(min)	kN	(kPa)	δ (mm)
457.80	-0.055	233.6	-0.2929
457.83	-0.056	233.4	-0.2947
457.87	-0.058	233.3	-0.2947
457.90	-0.057	233.3	-0.2956
457.93	-0.057	233.2	-0.2965
457.97	-0.058	233.2	-0.2982
458.00	-0.059	233	-0.3
458.03	-0.059	232.9	-0.3009
458.07	-0.06	232.8	-0.3027
458.10	-0.061	232.7	-0.3027
458.13	-0.062	232.7	-0.3045
458.17	-0.062	232.6	-0.3053
458.20	-0.061	232.5	-0.3062
458.23	-0.063	232.4	-0.308
458.27	-0.063	232.3	-0.3089
458.30	-0.064	232.2	-0.3098
458.33	-0.064	232.1	-0.3098
458.37	-0.065	232.1	-0.3107
458.40	-0.065	232	-0.3124
458.43	-0.065	231.9	-0.3133
458.47	-0.066	231.8	-0.3142
458.50	-0.067	231.7	-0.3151
458.53	-0.067	231.6	-0.316
458.57	-0.067	231.6	-0.316
458.60	-0.069	231.6	-0.3169
458.63	-0.069	231.4	-0.3187
458.67	-0.069	231.4	-0.3187
458.70	-0.069	231.3	-0.3196
458.73	-0.07	231.2	-0.3204
458.77	-0.07	231.1	-0.3213
458.80	-0.071	231	-0.3213
458.83	-0.071	231	-0.3231
458.87	-0.071	230.9	-0.324
458.90	-0.072	230.8	-0.3249
458.93	-0.072	230.8	-0.3258
458.97	-0.073	230.7	-0.3267
459.00	-0.073	230.6	-0.3275
459.03	-0.074	230.5	-0.3275
459.08	-0.074	230.5	-0.3293
459.12	-0.074	230.4	-0.3293
459.13	-0.075	230.3	-0.3293
459.17	-0.075	230.3	-0.3302
459.20	-0.075	230.2	-0.3311
459.23	-0.075	230.2	-0.332
459.27	-0.076	230.1	-0.332
459.30	-0.076	230	-0.3329
459.33	-0.077	229.9	-0.3338
459.37	-0.078	229.8	-0.3338
459.40	-0.078	229.8	-0.3346
459.43	-0.078	229.8	-0.3346
459.47	-0.077	229.7	-0.3355
459.50	-0.078	229.7	-0.3355
459.53	-0.078	229.6	-0.3364
459.57	-0.079	229.5	-0.3373
459.60	-0.079	229.5	-0.3373
459.63	-0.079	229.5	-0.3373
459.67	-0.079	229.4	-0.3382
459.70	-0.08	229.3	-0.3391

Prova triassiale ciclica SNME01-C3			
pressione di confinamento (kPa)		380	
deviatore ciclico (kPa)		80	
frequenza (hz)		0.00071429	
tempo	cella di carico	u	LVDT
(min)	kN	(kPa)	δ (mm)
459.73	-0.08	229.3	-0.3391
459.77	-0.08	229.2	-0.3391
459.80	-0.08	229.2	-0.34
459.83	-0.081	229.1	-0.34
459.87	-0.081	229.1	-0.3409
459.90	-0.081	229	-0.3409
459.93	-0.082	229	-0.3417
459.97	-0.082	229	-0.3417
460.00	-0.082	228.9	-0.3426
460.03	-0.082	228.8	-0.3426
460.07	-0.083	228.7	-0.3426
460.10	-0.082	228.7	-0.3435
460.13	-0.082	228.7	-0.3435
460.17	-0.082	228.7	-0.3435
460.20	-0.083	228.6	-0.3444
460.23	-0.083	228.6	-0.3444
460.27	-0.083	228.5	-0.3453
460.30	-0.083	228.5	-0.3453
460.33	-0.083	228.5	-0.3453
460.37	-0.083	228.5	-0.3453
460.40	-0.084	228.4	-0.3453
460.43	-0.084	228.4	-0.3462
460.47	-0.084	228.3	-0.3462
460.52	-0.083	228.3	-0.3462
460.55	-0.084	228.3	-0.3462
460.57	-0.084	228.2	-0.3471
460.60	-0.084	228.2	-0.3471
460.63	-0.084	228.2	-0.3471
460.67	-0.084	228.2	-0.3471
460.70	-0.084	228.1	-0.3471
460.73	-0.084	228.1	-0.348
460.77	-0.085	228.1	-0.348
460.80	-0.084	228.1	-0.348
460.83	-0.084	228	-0.348
460.87	-0.084	228	-0.348
460.90	-0.084	228	-0.348
460.93	-0.084	228	-0.348
460.97	-0.084	227.9	-0.348
461.00	-0.084	227.9	-0.348
461.03	-0.084	227.9	-0.3488
461.07	-0.084	227.9	-0.3488
461.10	-0.084	227.9	-0.3488
461.13	-0.084	227.9	-0.3488
461.17	-0.084	227.9	-0.3488
461.20	-0.084	227.8	-0.3488
461.23	-0.084	227.8	-0.3488
461.27	-0.084	227.8	-0.3488
461.30	-0.084	227.8	-0.3488
461.33	-0.083	227.8	-0.3488
461.37	-0.083	227.8	-0.3488
461.40	-0.083	227.8	-0.3488
461.43	-0.083	227.8	-0.3488
461.47	-0.083	227.7	-0.3488
461.50	-0.083	227.7	-0.3488
461.53	-0.083	227.7	-0.3488
461.57	-0.082	227.7	-0.3488
461.60	-0.082	227.7	-0.3488
461.63	-0.082	227.7	-0.3488

Prova triassiale ciclica SNME01-C3			
pressione di confinamento (kPa)		380	
deviatore ciclico (kPa)		80	
frequenza (hz)		0.00071429	
tempo	cella di carico	u	LVDT
(min)	kN	(kPa)	δ (mm)
461.67	-0.082	227.7	-0.3488
461.70	-0.082	227.7	-0.3488
461.73	-0.082	227.7	-0.3488
461.77	-0.082	227.7	-0.3488
461.80	-0.081	227.7	-0.3488
461.83	-0.081	227.7	-0.3488
461.87	-0.081	227.7	-0.348
461.90	-0.081	227.7	-0.348
461.93	-0.081	227.7	-0.348
461.98	-0.08	227.7	-0.348
462.02	-0.08	227.7	-0.348
462.03	-0.079	227.7	-0.348
462.07	-0.08	227.7	-0.348
462.10	-0.079	227.7	-0.348
462.13	-0.079	227.7	-0.348
462.17	-0.078	227.7	-0.348
462.20	-0.078	227.7	-0.3471
462.23	-0.079	227.7	-0.3471
462.27	-0.078	227.7	-0.3471
462.30	-0.078	227.7	-0.3471
462.33	-0.077	227.8	-0.3471
462.37	-0.077	227.8	-0.3471
462.40	-0.077	227.8	-0.3462
462.43	-0.077	227.8	-0.3462
462.47	-0.076	227.8	-0.3462
462.50	-0.076	227.8	-0.3462
462.53	-0.075	227.9	-0.3453
462.57	-0.075	227.9	-0.3453
462.60	-0.074	227.9	-0.3453
462.63	-0.074	227.9	-0.3453
462.67	-0.074	227.9	-0.3453
462.70	-0.074	227.9	-0.3444
462.73	-0.073	228	-0.3444
462.77	-0.073	228	-0.3444
462.80	-0.072	228	-0.3435
462.83	-0.071	228.1	-0.3435
462.87	-0.071	228.1	-0.3435
462.90	-0.071	228.1	-0.3426
462.93	-0.071	228.1	-0.3426
462.97	-0.07	228.2	-0.3417
463.00	-0.07	228.2	-0.3417
463.03	-0.07	228.2	-0.3417
463.07	-0.069	228.2	-0.3417
463.10	-0.068	228.2	-0.3409
463.13	-0.068	228.3	-0.3409
463.17	-0.068	228.3	-0.34
463.20	-0.067	228.3	-0.34
463.23	-0.066	228.4	-0.3391
463.27	-0.066	228.4	-0.3391
463.30	-0.065	228.5	-0.3391
463.33	-0.065	228.5	-0.3382
463.37	-0.065	228.5	-0.3382
463.40	-0.065	228.5	-0.3373
463.45	-0.063	228.6	-0.3373
463.47	-0.063	228.6	-0.3364
463.50	-0.063	228.6	-0.3364
463.53	-0.062	228.7	-0.3355
463.57	-0.062	228.7	-0.3355

Prova triassiale ciclica SNME01-C3			
ensione di confinamento (kPa)		380	
deviatore ciclico (kPa)		80	
frequenza (hz)		0.00071429	
tempo	cella di carico	u	LVDT
(min)	kN	(kPa)	δ (mm)
463.60	-0.061	228.8	-0.3346
463.63	-0.06	228.9	-0.3346
463.67	-0.06	228.9	-0.3338
463.70	-0.06	228.9	-0.3329
463.73	-0.059	229	-0.332
463.77	-0.058	229	-0.332
463.80	-0.057	229.1	-0.3311
463.83	-0.057	229.1	-0.3311
463.87	-0.056	229.2	-0.3311
463.90	-0.056	229.2	-0.3302
463.93	-0.056	229.2	-0.3293
463.97	-0.055	229.3	-0.3284
464.00	-0.054	229.4	-0.3275
464.03	-0.053	229.4	-0.3275
464.07	-0.053	229.5	-0.3267
464.10	-0.051	229.6	-0.3267
464.13	-0.051	229.6	-0.3249
464.17	-0.051	229.6	-0.3249
464.20	-0.051	229.7	-0.324
464.23	-0.05	229.7	-0.3231
464.27	-0.049	229.8	-0.3222
464.30	-0.048	229.9	-0.3213
464.33	-0.047	230	-0.3213
464.37	-0.046	230	-0.3204
464.40	-0.046	230.1	-0.3196
464.43	-0.046	230.1	-0.3187
464.47	-0.046	230.2	-0.3178
464.50	-0.045	230.2	-0.3169
464.53	-0.043	230.4	-0.3151
464.57	-0.043	230.4	-0.3151
464.60	-0.042	230.4	-0.3151
464.63	-0.042	230.5	-0.3142
464.67	-0.042	230.5	-0.3124
464.70	-0.04	230.6	-0.3116
464.73	-0.039	230.7	-0.3098
464.77	-0.039	230.8	-0.3098
464.80	-0.038	230.8	-0.3098
464.83	-0.037	230.8	-0.308
464.88	-0.037	231	-0.3062
464.92	-0.036	231.1	-0.3062
464.93	-0.036	231.1	-0.3045
464.97	-0.036	231.1	-0.3036
465.00	-0.034	231.3	-0.3018
465.03	-0.033	231.4	-0.3
465.07	-0.033	231.4	-0.2991
465.10	-0.032	231.5	-0.2974
465.13	-0.031	231.6	-0.2974
465.17	-0.03	231.6	-0.2965
465.20	-0.03	231.7	-0.2947
465.23	-0.029	231.8	-0.2929
465.27	-0.028	231.9	-0.2911
465.30	-0.028	232	-0.2903
465.33	-0.026	232.1	-0.2876
465.37	-0.026	232.2	-0.2876
465.40	-0.024	232.2	-0.2858
465.43	-0.024	232.3	-0.2832
465.47	-0.024	232.4	-0.2823
465.50	-0.024	232.5	-0.2805

SNM301-C3 prova TXC

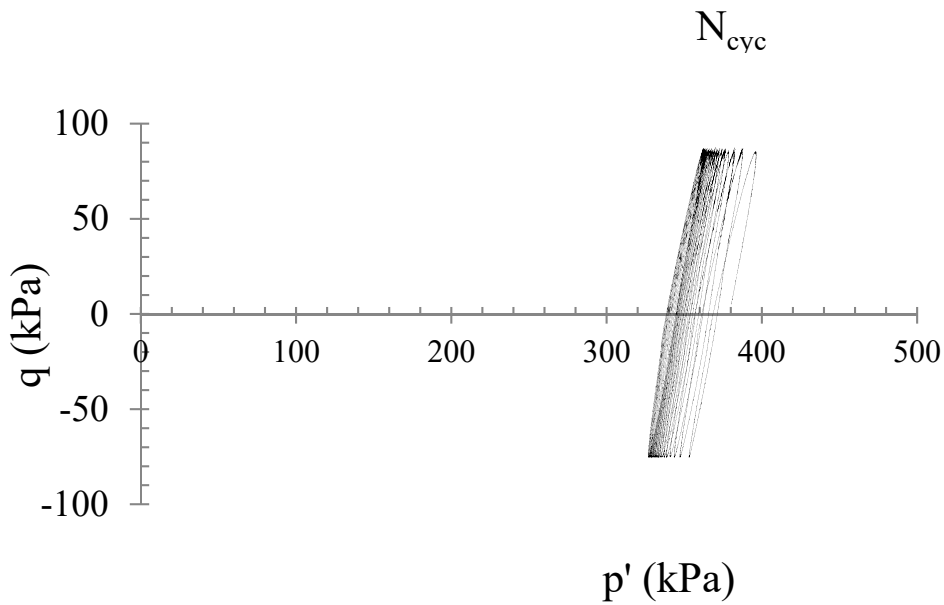
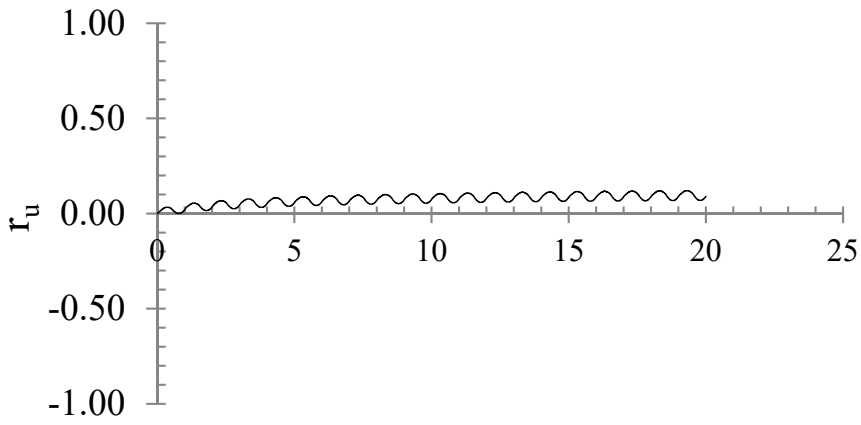
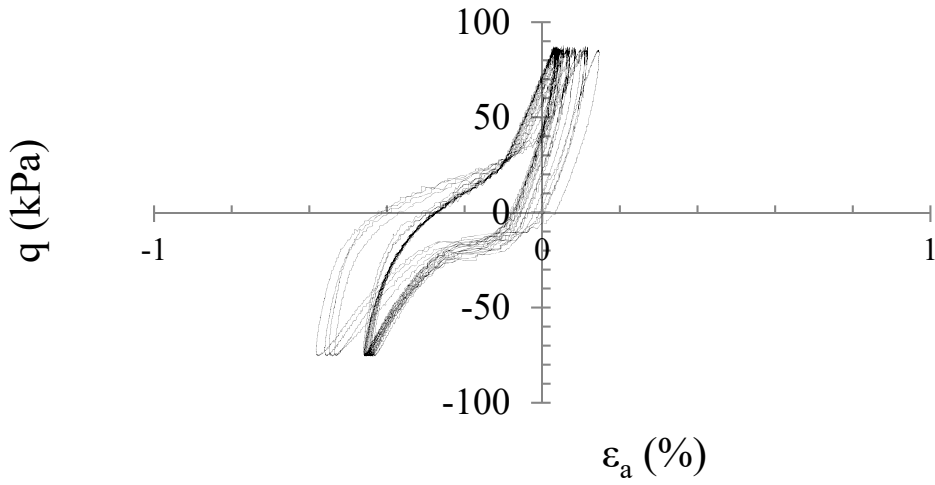

SNM301-C3 prova TXC

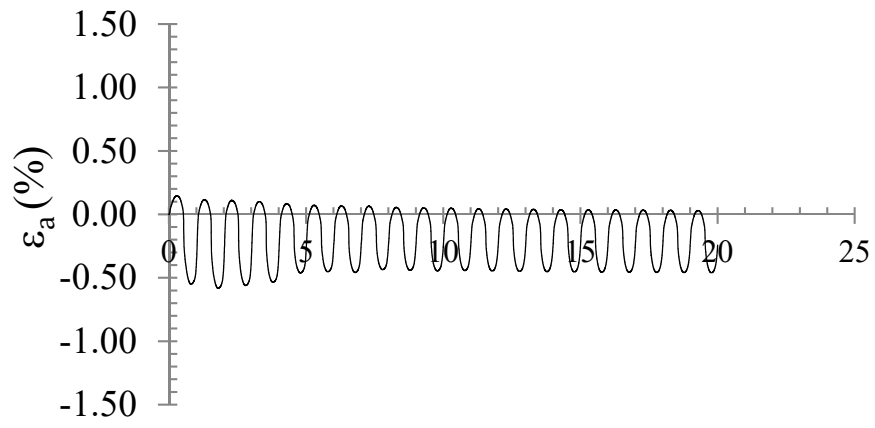

N_{cyc}



Università degli Studi di Napoli Federico II
Dipartimento di Ingegneria Idraulica,
Geotecnica ed Ambientale

Prova Compressione Triassiale n.		Celle n.
Prova tipo	CU (consolidata non drenata)	
Committente	Consorzio Hirpinia AV	
Indagine	I lotto funzionale Apice-Hirpinia	
Sondaggio	SN_ME 01	
Campione	3	
Profondità	17.80 ÷ 18.40 m	

Provino 1 Condizioni inizio prova			Provino 2 Condizioni inizio prova			Provino 3 Condizioni inizio prova		
altezza ho	mm	71.88	altezza ho	mm	71.86	altezza ho	mm	71.85
diámetro d	mm	35.56	diámetro d	mm	35.65	diámetro d	mm	35.55
peso umido iniziale	g	152.73	peso umido iniziale	g	153.49	peso umido iniziale	g	153.00
Peso specifico γ_s	kN/m ³	27.07	Peso specifico γ_s	kN/m ³	27.07	Peso specifico γ_s	kN/m ³	27.07
Peso secco dell'udv γ_d	kN/m ³	17.66	Peso secco dell'udv γ_d	kN/m ³	17.77	Peso secco dell'udv γ_d	kN/m ³	17.63
Contenuto d'acqua w		0.188	Contenuto d'acqua w		0.187	Contenuto d'acqua w		0.193
Peso umido dell'udv γ	kN/m ³	20.99	Peso umido dell'udv γ	kN/m ³	21.09	Peso umido dell'udv γ	kN/m ³	21.03
Indice dei vuoti e		0.533	Indice dei vuoti e		0.523	Indice dei vuoti e		0.536
Grado di saturazione Sr		1.0	Grado di saturazione Sr		1.0	Grado di saturazione Sr		1.0
Condizioni fine prova			Condizioni fine prova			Condizioni fine prova		
Pesafiltro n° 20	g	15.53	Pesafiltro n° 17	g	20.71	Pesafiltro n° 23	g	14.31
Pf + prov. umido	g	167.35	Pf + prov. umido	g	173.02	Pf + prov. umido	g	166.02
Pf + prov.secco	g	144.06	Pf + prov.secco	g	150.05	Pf + prov.secco	g	142.58
Peso secco dell'udv γ_d	kN/m ³	17.79	Peso secco dell'udv γ_d	kN/m ³	17.94	Peso secco dell'udv γ_d	kN/m ³	18.00
Contenuto d'acqua w		0.181	Contenuto d'acqua w		0.178	Contenuto d'acqua w		0.183
Peso umido dell'udv γ	kN/m ³	21.01	Peso umido dell'udv γ	kN/m ³	21.13	Peso umido dell'udv γ	kN/m ³	21.29
Indice dei vuoti e		0.522	Indice dei vuoti e		0.509	Indice dei vuoti e		0.504
Grado di saturazione Sr		1.0	Grado di saturazione Sr		1.0	Grado di saturazione Sr		1.0

Laboratorio di Geotecnica

Prova Compressione Triassiale n.		Prova Compressione Triassiale n.		Prova Compressione Triassiale n.				
CIU (consolidata non drenata)		CIU (consolidata non drenata)		CIU (consolidata non drenata)				
Provino 1		Provino 2		Provino 3				
Velocità di prova (mm/min)	0.01	Velocità di prova (mm/min)	0.01	Velocità di prova (mm/min)	0.01			
tensione di confinamento (kPa)	380	tensione di confinamento (kPa)	500	tensione di confinamento (kPa)	600			
LVDT	cella di carico	Δu	LVDT	cella di carico	Δu	LVDT	cella di carico	Δu
δ (mm)	kg	(kPa)	δ (mm)	kg	(kPa)	δ (mm)	kg	(kPa)
0	0	0	0	0	0	0	0	0
0.001	0.892	0.300	0.001	0.102	0.200	0.001	0.255	2.114
0.002	1.024	0.400	0.003	0.153	0.253	0.003	1.726	4.097
0.003	1.142	0.500	0.005	0.193	0.300	0.004	4.059	6.488
0.005	1.176	0.608	0.007	0.278	0.396	0.006	5.734	8.894
0.007	1.226	0.700	0.009	0.344	0.500	0.008	7.307	11.445
0.009	1.264	0.800	0.011	0.420	0.600	0.009	8.729	13.341
0.010	1.278	0.860	0.013	0.476	0.638	0.010	9.624	14.900
0.012	1.319	0.900	0.015	0.538	0.700	0.011	10.593	16.300
0.014	1.319	0.955	0.016	0.618	0.800	0.013	11.571	17.496
0.016	1.355	1.033	0.017	0.684	0.900	0.014	12.692	19.200
0.017	1.415	1.100	0.018	0.745	1.000	0.015	13.766	20.180
0.019	1.425	1.166	0.019	0.814	1.100	0.017	14.573	21.450
0.021	1.453	1.200	0.020	0.899	1.200	0.018	15.477	22.280
0.022	1.497	1.260	0.021	1.000	1.300	0.019	16.341	23.146
0.024	1.505	1.340	0.023	1.068	1.400	0.020	16.882	24.250
0.026	1.533	1.400	0.024	1.142	1.500	0.021	17.908	25.260
0.027	1.533	1.472	0.025	1.208	1.600	0.022	18.449	26.280
0.029	1.557	1.519	0.027	1.283	1.700	0.024	19.247	27.550
0.031	1.568	1.555	0.028	1.363	1.800	0.025	20.112	29.200
0.033	1.580	1.596	0.030	1.407	1.900	0.027	21.024	30.300
0.034	1.600	1.645	0.031	1.441	2.000	0.028	21.831	31.400
0.036	1.604	1.700	0.033	1.509	2.100	0.030	22.696	32.300
0.038	1.632	1.751	0.034	1.557	2.151	0.031	23.503	33.300
0.039	1.640	1.840	0.035	1.604	2.200	0.032	23.988	33.971
0.040	1.679	1.900	0.035	1.637	2.300	0.033	24.577	35.050
0.042	1.711	1.955	0.036	1.670	2.400	0.035	25.223	36.010
0.044	1.750	2.000	0.037	1.708	2.442	0.036	25.973	37.090
0.046	1.783	2.064	0.039	1.750	2.500	0.037	26.999	38.230
0.048	1.817	2.140	0.040	1.800	2.600	0.038	27.854	39.060
0.049	1.854	2.208	0.041	1.868	2.700	0.039	28.662	40.080
0.051	1.892	2.255	0.042	1.948	2.800	0.041	29.574	41.670
0.052	1.925	2.283	0.044	2.075	2.900	0.045	30.163	43.190
0.054	1.925	2.351	0.046	2.208	3.000	0.050	31.407	45.230
0.056	1.960	2.400	0.048	2.340	3.100	0.054	32.262	46.357
0.057	1.995	2.500	0.050	2.543	3.300	0.061	33.070	47.458
0.059	2.032	2.618	0.052	2.831	3.500	0.067	33.716	48.479
0.061	2.103	2.700	0.053	3.035	3.700	0.077	34.419	50.301
0.063	2.211	2.800	0.055	3.272	3.800	0.088	35.169	51.467
0.064	2.211	2.900	0.056	3.533	4.000	0.096	35.597	52.561
0.066	2.281	3.000	0.057	3.848	4.300	0.106	36.138	53.509
0.067	2.352	3.100	0.058	4.069	4.500	0.116	36.727	54.383
0.068	2.460	3.200	0.060	4.340	4.700	0.127	37.249	55.185
0.070	2.542	3.300	0.061	4.493	4.900	0.135	37.696	56.206
0.072	2.603	3.429	0.061	4.713	5.100	0.147	37.962	57.240
0.074	2.642	3.561	0.062	4.900	5.300	0.156	38.111	58.320
0.076	2.674	3.679	0.064	5.154	5.500	0.166	38.314	59.268
0.077	2.709	3.807	0.065	5.391	5.800	0.174	38.365	60.070
0.079	2.781	3.900	0.066	5.680	6.000	0.186	38.467	60.799
0.080	2.821	3.995	0.068	5.883	6.200	0.196	38.669	61.528
0.082	2.852	4.100	0.068	6.036	6.500	0.205	38.822	62.184
0.084	2.915	4.160	0.071	6.205	6.700	0.215	39.025	62.840
0.086	2.986	4.274	0.071	6.409	6.900	0.225	39.176	63.423
0.094	3.101	4.373	0.072	6.629	7.100	0.235	39.329	64.444
0.105	3.208	4.486	0.075	6.917	7.400	0.245	39.431	65.391

Laboratorio di Geotecnica								
Prova Compressione Triassiale n.			Prova Compressione Triassiale n.			Prova Compressione Triassiale n.		
CIU (consolidata non drenata)			CIU (consolidata non drenata)			CIU (consolidata non drenata)		
Provino 1			Provino 2			Provino 3		
Velocità di prova (mm/min)	0.01		Velocità di prova (mm/min)	0.01		Velocità di prova (mm/min)	0.01	
tensione di confinamento (kPa)	380		tensione di confinamento (kPa)	500		tensione di confinamento (kPa)	600	
LVDT	cella di carico	Au	LVDT	cella di carico	Au	LVDT	cella di carico	Au
δ (mm)	kg	(kPa)	δ (mm)	kg	(kPa)	δ (mm)	kg	(kPa)
0.116	3.422	4.800	0.075	7.087	7.600	0.256	39.533	66.047
0.126	3.707	5.300	0.076	7.273	7.800	0.264	39.634	66.631
0.135	4.135	5.600	0.077	7.443	8.100	0.276	39.785	67.214
0.143	4.741	6.200	0.085	8.545	9.500	0.285	39.938	67.724
0.153	5.418	6.900	0.092	9.579	11.000	0.295	40.091	68.162
0.163	6.239	7.900	0.100	10.579	12.500	0.305	40.142	68.599
0.170	6.595	9.000	0.109	11.478	13.900	0.315	40.293	69.620
0.180	7.094	10.200	0.117	12.275	15.400	0.326	40.395	70.494
0.190	7.950	11.300	0.125	13.105	17.000	0.336	40.496	71.005
0.199	8.840	12.300	0.133	13.902	18.500	0.346	40.598	71.442
0.209	9.696	13.800	0.141	14.665	20.000	0.355	40.749	71.879
0.218	10.445	15.400	0.151	15.428	21.500	0.365	40.851	72.317
0.223	11.157	17.300	0.159	16.089	23.000	0.375	40.902	72.608
0.235	11.764	19.100	0.167	16.649	24.500	0.386	40.902	73.046
0.246	12.370	20.800	0.176	17.310	26.000	0.396	41.055	73.921
0.253	12.976	22.500	0.184	17.920	27.500	0.404	41.157	74.723
0.263	13.546	24.200	0.193	18.497	29.000	0.417	41.258	75.160
0.273	14.081	25.800	0.202	19.022	30.500	0.426	41.358	75.597
0.283	14.579	27.400	0.210	19.548	31.900	0.476	41.715	77.930
0.292	14.973	29.000	0.218	20.022	33.300	0.527	41.968	79.753
0.302	15.400	30.700	0.228	20.378	34.700	0.577	42.373	82.013
0.312	15.757	32.200	0.236	20.785	36.100	0.628	42.577	83.179
0.322	16.149	33.700	0.245	21.192	37.400	0.675	42.831	85.001
0.331	16.469	35.000	0.254	21.599	38.800	0.723	43.186	86.605
0.341	16.825	36.300	0.263	22.006	40.200	0.771	43.541	88.209
0.349	17.147	37.500	0.271	22.362	41.400	0.820	43.795	89.375
0.361	17.396	38.700	0.281	22.633	42.700	0.869	43.897	90.177
0.369	17.610	39.800	0.289	22.871	43.900	0.920	44.099	91.562
0.379	17.823	41.100	0.297	23.159	45.100	0.970	44.404	92.948
0.389	18.037	42.300	0.307	23.481	46.300	1.021	44.555	94.114
0.401	18.252	43.300	0.315	23.803	47.400	1.070	44.759	95.353
0.408	18.430	44.200	0.324	24.040	48.500	1.122	45.014	96.593
0.418	18.644	45.100	0.332	24.329	49.700	1.174	45.165	97.613
0.430	18.822	46.000	0.340	24.498	50.800	1.223	45.317	98.634
0.438	18.964	46.900	0.349	24.702	51.800	1.274	45.521	99.450
0.450	19.107	47.600	0.358	24.939	52.800	1.377	45.876	100.967
0.460	19.250	48.400	0.366	25.176	53.900	1.479	46.130	103.008
0.470	19.428	49.300	0.376	25.380	54.800	1.584	46.383	104.320
0.478	19.606	50.000	0.384	25.600	55.800	1.687	46.738	105.190
0.488	19.713	50.700	0.393	25.854	56.800	1.789	46.839	105.778
0.500	19.820	51.200	0.401	25.990	57.700	1.894	47.094	106.361
0.510	19.927	51.900	0.411	26.126	58.600	2.000	46.992	106.653
0.518	20.069	52.500	0.419	26.312	59.500	2.102	47.196	106.660
0.528	20.212	53.000	0.429	26.482	60.400	2.207	47.094	106.400
0.540	20.320	53.700	0.438	26.668	61.300	2.311	47.347	106.180
0.548	20.426	54.400	0.446	26.855	62.100	2.417	47.398	105.900
0.600	20.889	54.900	0.456	27.041	62.900	2.522	47.449	105.341
0.650	21.246	55.400	0.464	27.160	63.600	2.628	47.449	104.247
0.700	21.602	57.800	0.473	27.245	64.500	2.734	47.449	103.400
0.752	21.923	59.600	0.483	27.380	65.200	2.836	47.347	102.000
0.802	22.208	61.300	0.491	27.567	66.000	2.943	47.398	100.602
0.853	22.458	62.600	0.537	28.211	69.500	3.049	47.449	99.200
0.906	22.743	63.900	0.582	28.889	72.600	3.155	47.398	97.400
0.958	22.921	65.100	0.629	29.432	75.400	3.261	47.398	95.200
1.008	23.029	66.200	0.675	29.872	77.800	3.367	47.347	93.300
1.060	23.242	66.800	0.723	30.313	80.200	3.473	47.347	91.200
1.111	23.421	67.400	0.770	30.788	82.300	3.579	47.245	89.011
1.164	23.564	68.000	0.818	31.076	84.200	3.683	47.196	87.261
1.216	23.670	68.800	0.865	31.398	85.800	3.791	47.094	85.876
1.267	23.848	69.700	0.914	31.670	87.400	3.895	47.043	84.564
1.319	23.991	71.000	0.963	32.026	88.900	4.003	46.992	83.100
1.372	24.097	71.500	1.010	32.297	90.200	4.109	46.788	81.700
1.425	24.205	72.400	1.058	32.483	91.300	4.215	46.687	80.600
1.529	24.383	72.400	1.107	32.856	92.500	4.319	46.587	79.600

Laboratorio di Geotecnica								
Prova Compressione Triassiale n.			Prova Compressione Triassiale n.			Prova Compressione Triassiale n.		
CIU (consolidata non drenata)			CIU (consolidata non drenata)			CIU (consolidata non drenata)		
Provino 1			Provino 2			Provino 3		
Velocità di prova (mm/min)		0.01	Velocità di prova (mm/min)		0.01	Velocità di prova (mm/min)		0.01
tensione di confinamento (kPa)		380	tensione di confinamento (kPa)		500	tensione di confinamento (kPa)		600
LVDT	cella di carico	Au	LVDT	cella di carico	Au	LVDT	cella di carico	Au
δ (mm)	kg	(kPa)	δ (mm)	kg	(kPa)	δ (mm)	kg	(kPa)
1.632	24.525	72.700	1.154	33.094	93.400	4.427	46.536	78.440
1.740	24.703	73.900	1.202	33.263	94.200	4.531	46.281	77.400
1.843	24.882	74.800	1.249	33.467	95.000	4.639	46.230	76.472
1.949	25.024	75.600	1.298	33.772	95.600	4.745	45.977	75.233
2.053	25.132	75.500	1.396	33.992	96.600	4.849	46.079	74.723
2.159	25.203	76.000	1.492	34.399	97.400	4.955	45.774	73.629
2.265	25.274	76.500	1.588	34.704	97.900	5.061	45.672	72.900
2.368	25.381	76.500	1.685	35.077	98.300	5.164	45.470	71.879
2.477	25.452	76.500	1.781	35.298	98.500	5.272	45.419	71.005
2.583	25.559	76.200	1.878	35.586	98.400	5.375	45.266	69.984
2.689	25.702	76.200	1.975	35.806	98.200	5.484	45.165	68.891
2.795	25.773	76.200	2.071	36.061	97.800	5.588	45.114	68.089
2.899	25.881	75.300	2.166	36.315	97.300	5.694	45.063	67.287
3.008	25.951	74.000	2.264	36.451	96.600	5.800	45.014	66.120
3.116	25.951	72.500	2.359	36.688	96.000	5.906	44.759	65.173
3.221	26.059	70.500	2.455	36.868	95.100	6.011	44.657	64.152
3.329	26.094	68.300	2.551	37.061	94.200	6.117	44.404	63.059
3.438	26.165	65.800	2.646	37.196	93.100	6.224	44.353	62.038
3.545	26.094	62.600	2.741	37.451	91.900	6.330	44.303	60.600
3.651	26.165	59.800	2.835	37.533	90.700	6.436	44.303	59.400
3.760	26.130	56.300	2.931	37.642	89.400	6.530	44.303	58.300
3.869	26.165	53.500	3.025	37.750	88.100	6.652	44.252	57.081
3.976	26.130	50.900	3.121	37.835	86.700	6.756	44.150	55.987
4.086	26.130	48.900	3.213	37.896	85.300	6.861	44.048	54.900
4.194	26.130	46.600	3.308	37.953	83.800	6.967	44.099	53.582
4.301	26.201	44.100	3.402	37.993	82.200	7.074	43.948	52.500
4.410	26.165	42.700	3.495	38.095	80.700	7.180	43.948	51.030
4.519	26.165	39.700	3.589	38.112	79.300	7.286	43.846	49.864
4.627	26.165	38.190	3.684	38.184	77.600	7.391	43.846	48.770
4.738	26.165	36.000	3.777	38.222	76.000	7.495	43.642	47.750
4.845	26.236	34.730	3.871	38.231	74.400	7.601	43.693	46.510
4.954	26.201	33.700	3.964	38.259	72.800	7.702	43.846	45.563
5.064	26.201	32.400	4.058	38.288	71.200	7.808	43.846	44.688
5.172	26.165	31.000	4.153	38.307	69.500	7.911	43.744	43.886
5.282	26.130	29.700	4.245	38.307	67.900	8.017	43.795	42.792
5.391	26.130	28.510	4.340	38.315	66.300	8.117	43.744	41.845
5.499	26.094	26.950	4.434	38.292	64.600	8.221	43.846	41.100
5.608	26.059	25.900	4.527	38.311	63.100	8.324	44.048	40.022
5.718	26.094	24.400	4.621	38.311	61.500	8.426	43.846	39.293
5.826	26.094	22.800	4.714	38.325	59.900	8.528	43.897	38.200
5.938	26.094	21.400	4.808	38.332	58.300	8.629	43.744	36.887
6.045	26.094	20.000	4.902	38.315	56.700	8.730	43.846	35.794
6.152	26.022	19.100	4.997	38.292	55.300	8.831	43.744	34.482
6.261	26.059	17.400	5.090	38.248	54.000	8.932	43.795	33.461
6.370	25.987	15.800	5.184	38.231	52.400	9.030	43.744	32.368
6.479	26.022	14.400	5.277	38.212	50.800	9.133	43.897	31.347
6.586	25.951	12.900	5.371	38.214	49.300	9.231	43.744	30.490
6.695	25.951	11.300	5.466	38.189	47.800	9.332	43.795	29.743
6.802	25.987	10.300	5.559	38.180	46.300	9.428	43.846	29.200
6.908	25.987	9.300	5.652	38.146	44.800	9.531	43.744	28.440
7.017	25.987	8.680	5.747	38.129	43.400	9.627	43.795	27.990
7.126	25.951	7.950	5.840	38.113	41.900	9.725	43.795	27.200
7.233	25.987	7.130	5.934	38.095	40.500	9.823	43.897	26.800
7.341	25.951	6.220	6.026	38.090	39.200	9.921	43.744	26.230
7.448	25.987	5.300	6.120	38.090	37.900	10.017	43.744	25.650
7.557	25.916	4.320	6.213	38.095	36.500	10.113	43.693	25.020
7.663	25.951	3.460	6.307	38.078	35.200	10.211	43.744	24.750
7.770	25.916	2.500	6.400	38.061	33.900	10.307	43.541	24.300
7.879	25.987	1.500	6.493	38.044	32.600	10.403	43.490	24.030
7.985	25.916	0.800	6.588	38.027	31.300	10.500	43.490	23.550
8.092	25.916	-0.400	6.680	38.005	30.100	10.599	43.390	23.130
8.198	25.844	-1.870	6.775	37.993	28.900	10.692	43.339	22.860
8.306	25.844	-3.030	6.867	38.019	27.700	10.788	43.237	22.600
8.413	25.809	-4.400	6.960	38.027	26.400	10.883	43.237	22.420

Laboratorio di Geotecnica								
Prova Compressione Triassiale n.			Prova Compressione Triassiale n.			Prova Compressione Triassiale n.		
CIU (consolidata non drenata)			CIU (consolidata non drenata)			CIU (consolidata non drenata)		
Provino 1			Provino 2			Provino 3		
Velocità di prova (mm/min)	0.01		Velocità di prova (mm/min)	0.01		Velocità di prova (mm/min)	0.01	
tensione di confinamento (kPa)	380		tensione di confinamento (kPa)	500		tensione di confinamento (kPa)	600	
LVDT	cella di carico	Au	LVDT	cella di carico	Au	LVDT	cella di carico	Au
δ (mm)	kg	(kPa)	δ (mm)	kg	(kPa)	δ (mm)	kg	(kPa)
8.519	25.844	-5.640	7.054	38.024	25.300	10.978	43.084	22.230
8.626	25.844	-6.400	7.148	37.993	24.100	11.071	43.033	22.150
8.732	25.844	-7.400	7.241	38.000	23.200	11.160	42.931	21.960
8.838	25.881	-8.100	7.335	37.976	21.900	11.250	42.831	21.810
8.944	25.881	-8.710	7.427	37.995	20.800	11.343	42.931	21.580
9.052	25.844	-9.800	7.522	37.981	19.800	11.434	42.931	21.320
9.156	25.773	-10.700	7.616	37.986	18.700	11.527	42.831	21.250
9.262	25.773	-11.400	7.709	37.995	17.700	11.617	42.831	20.980
9.368	25.809	-12.400	7.803	37.976	16.700	11.707	42.730	20.790
9.475	25.809	-13.000	7.896	37.976	15.600	11.798	42.730	20.600
9.581	25.738	-14.200	7.990	37.993	14.700	11.888	42.882	20.490
9.686	25.773	-14.800	8.085	37.986	13.600	11.976	42.831	20.260
9.790	25.809	-16.300	8.178	37.993	12.700	12.066	42.982	20.080
9.896	25.773	-17.050	8.273	38.005	11.800	12.152	43.186	19.850
10.002	25.773	-17.800	8.368	38.009	10.700	12.242	43.288	19.660
10.107	25.702	-18.670	8.463	37.993	9.900	12.327	43.135	19.580
10.211	25.702	-19.400	8.558	38.005	8.900	12.416	43.033	19.510
10.314	25.667	-20.100	8.653	38.010	8.000	12.500	42.780	19.360
10.419	25.667	-20.400	8.749	38.024	7.000	12.586	42.780	19.320
10.522	25.595	-21.290	8.846	38.038	6.100	12.671	42.780	19.320
10.627	25.595	-21.850	8.942	38.061	5.200	12.754	42.931	19.170
10.728	25.559	-22.400	9.037	38.061	4.400	12.839	42.982	19.090
10.831	25.595	-22.810	9.133	38.095	3.500	12.920	42.882	18.980
10.934	25.595	-23.300	9.230	38.078	2.700	13.004	43.186	18.910
11.037	25.559	-23.700	9.327	38.078	2.000	13.085	43.135	18.830
11.141	25.559	-24.060	9.425	38.075	1.100	13.163	43.186	18.640
11.242	25.487	-24.400	9.521	38.061	0.300	13.247	43.033	18.530
11.344	25.524	-24.600	9.617	38.080	-0.500	13.327	42.882	18.380
11.447	25.452	-24.860	9.714	38.112	-1.300	13.406	42.831	18.230
11.549	25.452	-25.020	9.813	38.104	-2.100	13.486	42.982	18.190
11.650	25.417	-25.180	9.910	38.129	-2.800	13.563	42.931	18.040
11.752	25.452	-25.400	10.007	38.112	-3.500	13.641	42.831	17.960
11.854	25.452	-25.530	10.104	38.146	-4.300	13.721	42.931	17.890
11.957	25.417	-25.720	10.202	38.160	-5.000	13.796	42.882	17.700
12.057	25.346	-26.040	10.300	38.165	-5.700	13.873	43.033	17.740
12.161	25.346	-26.230	10.399	38.163	-6.300	13.948	43.084	17.660
12.262	25.346	-26.450	10.496	38.163	-7.000	14.012	42.831	17.740
12.365	25.310	-26.700	10.595	38.184	-7.600	14.096	42.730	17.700
12.466	25.310	-26.770	10.693	38.180	-8.200	14.170	42.730	17.660
12.569	25.274	-27.050	10.793	38.222	-8.800	14.242	42.577	17.740
12.671	25.346	-27.290	10.892	38.265	-9.300	14.315	42.628	17.700
12.773	25.274	-27.520	10.991	38.259	-9.900	14.385	42.526	17.660
12.876	25.238	-27.700	11.090	38.292	-10.500			
12.977	25.132	-27.920	11.191	38.315	-11.100			
13.079	25.095	-28.140	11.291	38.335	-11.600			
13.181	25.060	-28.320	11.390	38.349	-12.100			
13.284	25.024	-28.700	11.491	38.368	-12.500			
13.387	24.989	-28.840	11.592	38.417	-13.000			
13.490	24.954	-29.190	11.693	38.439	-13.500			
13.592	24.989	-29.310	11.794	38.485	-14.100			
13.695	24.954	-29.400	11.896	38.491	-14.600			
13.798	24.918	-29.700	11.998	38.519	-15.100			
13.900	24.811	-29.800	12.099	38.557	-15.500			
14.003	24.775	-29.980	12.203	38.590	-15.900			
14.106	24.703	-30.060	12.306	38.621	-16.500			
14.207	24.703	-30.210	12.409	38.665	-16.900			
14.310	24.668	-30.330	12.513	38.688	-17.300			
14.412	24.597	-30.430	12.618	38.717	-17.700			
		-30.480	12.722	38.739	-18.100			
		-30.680	12.826	38.773	-18.600			
			12.932	38.792	-18.900			
			13.039	38.797	-19.300			
			13.145	38.816	-19.700			
			13.251	38.824	-20.100			
			13.357	38.841	-20.400			
			13.464	38.875	-20.900			
			13.571	38.887	-21.270			
			13.678	38.909	-21.650			
			13.785	38.929	-22.000			
			13.894	38.915	-22.400			
			14.001	38.926	-22.700			
			14.110	38.948	-23.100			
			14.218	38.960	-23.300			
			14.327	38.960	-23.600			
			14.435	38.995	-23.900			

Prova Triassiale CIU SNME01-C3

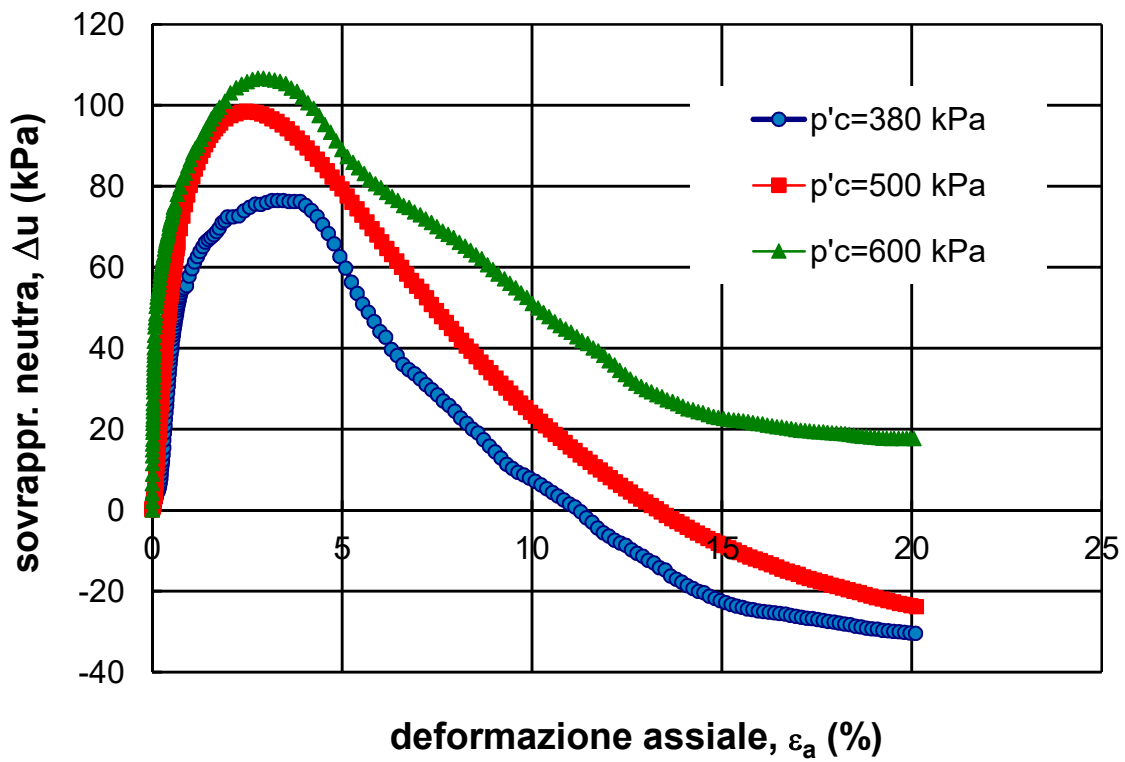
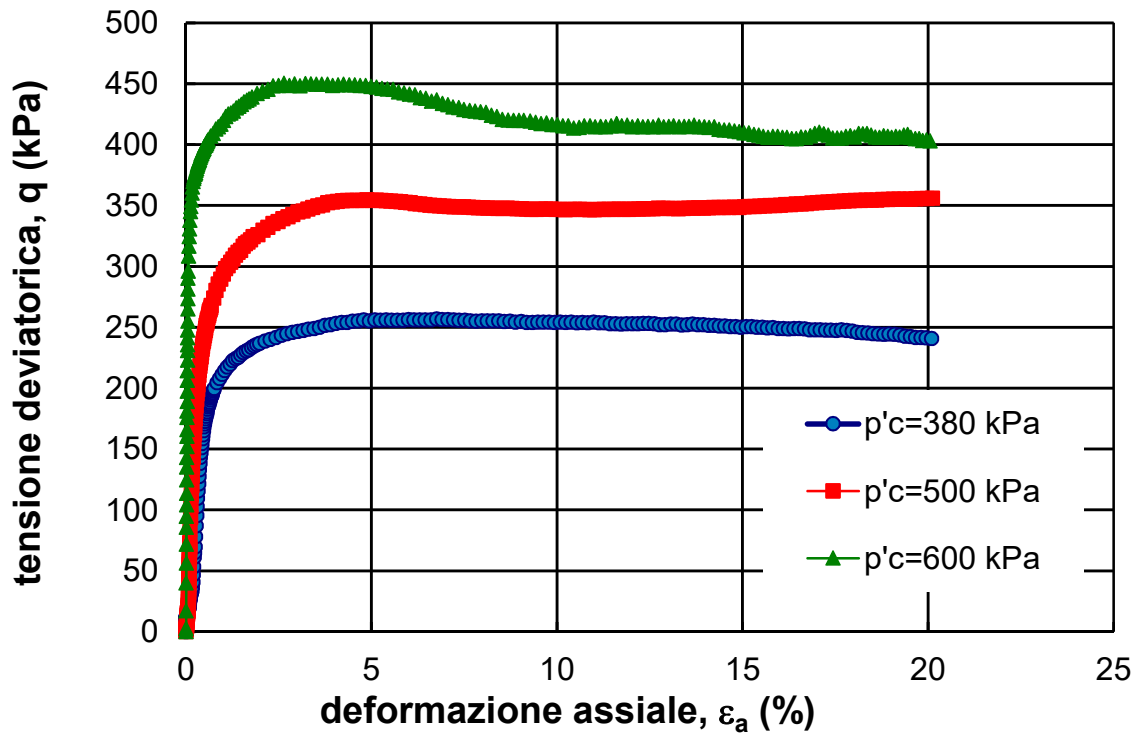

Prova Triassiale CIU SNME01-C3

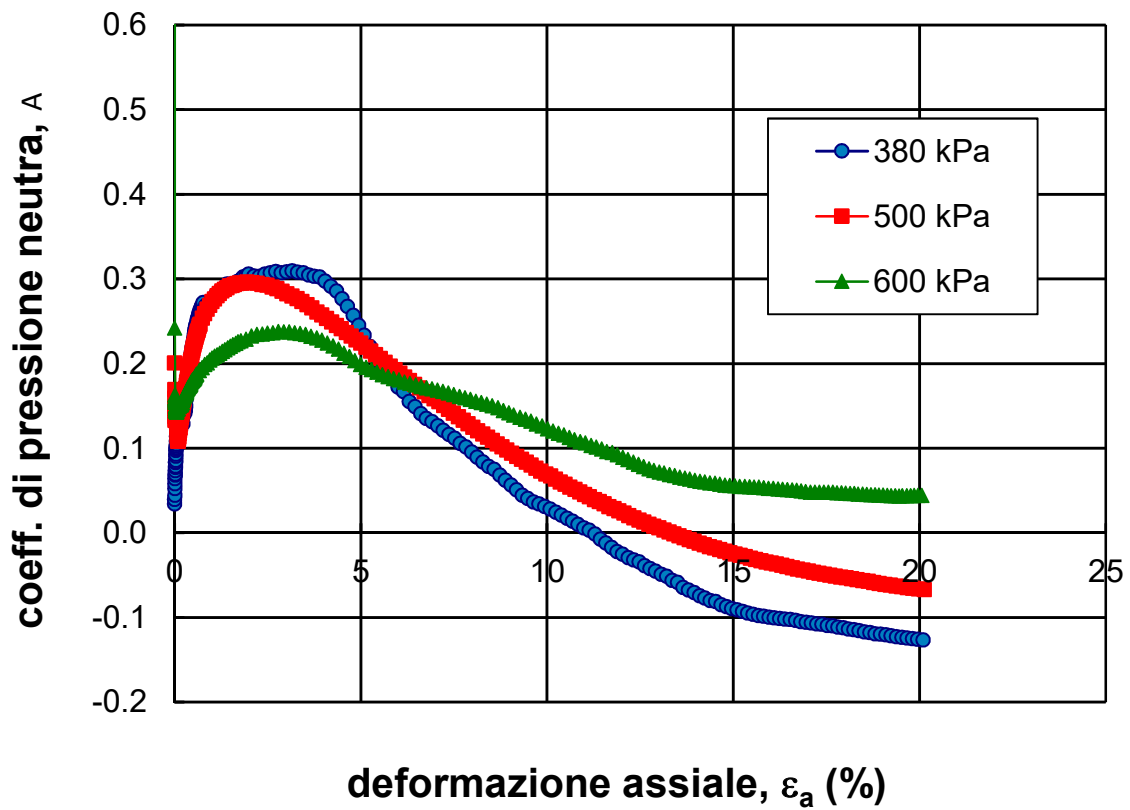
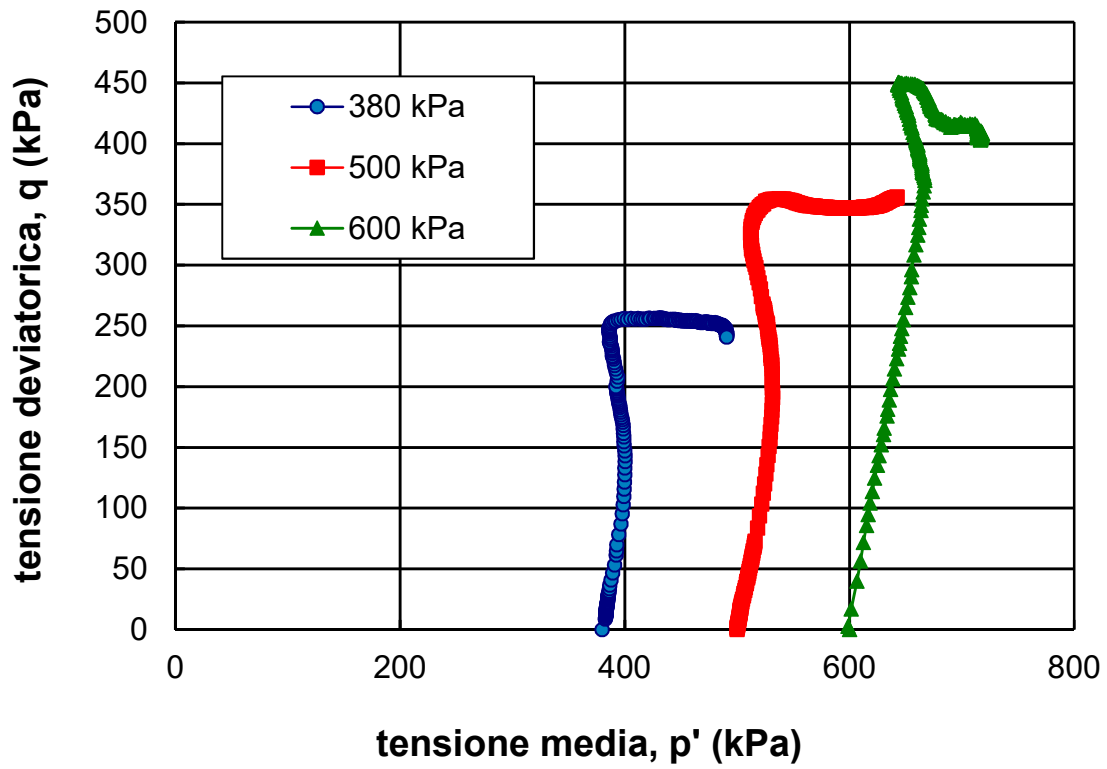

Prova Triassiale CIU SNME01-C3

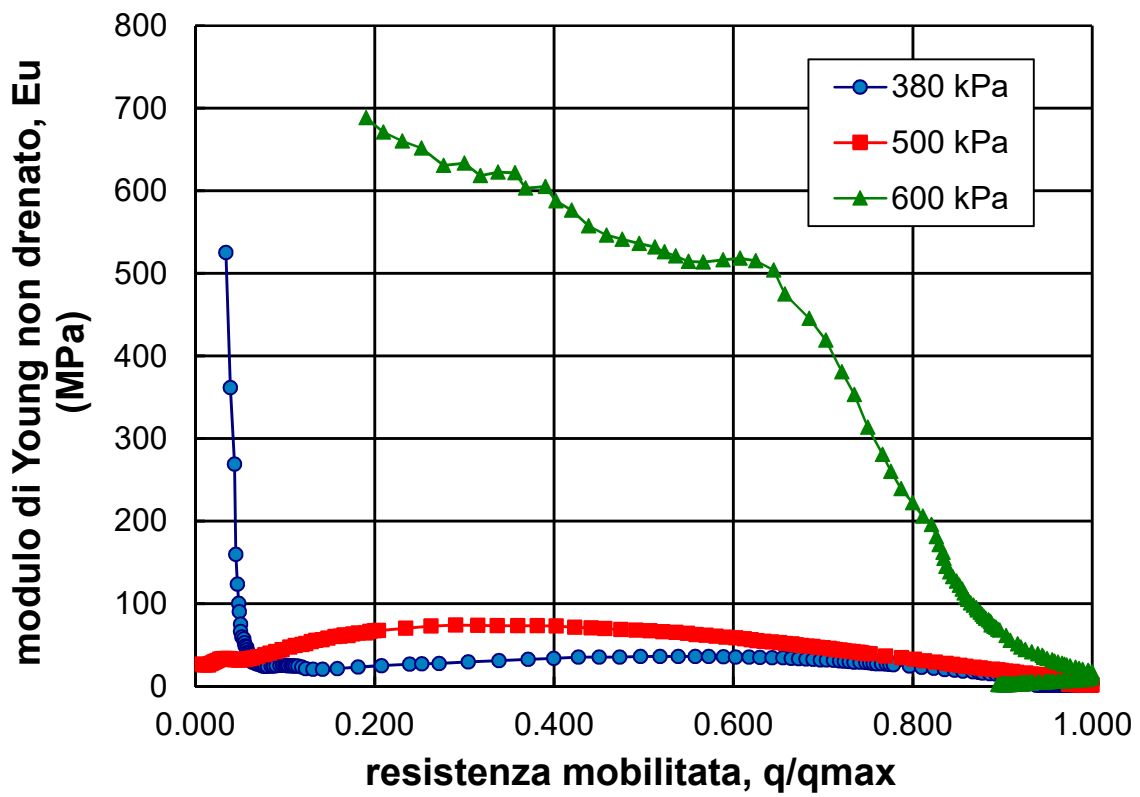
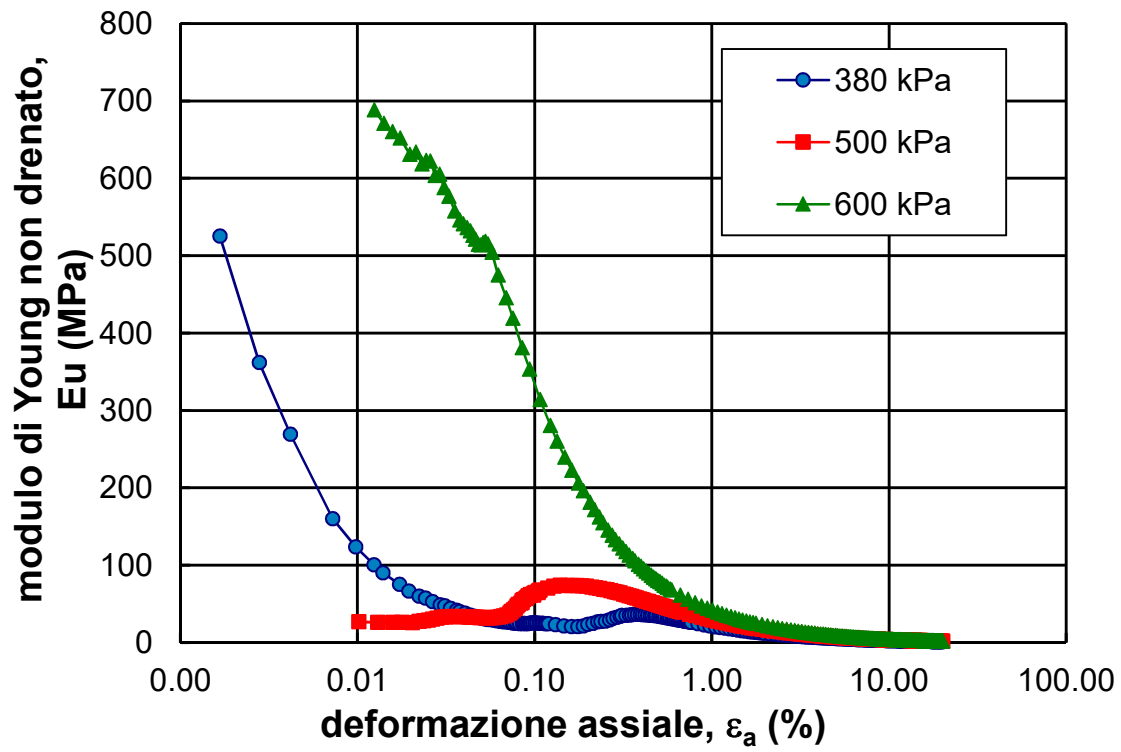

Prova Triassiale CIU SNME01-C3

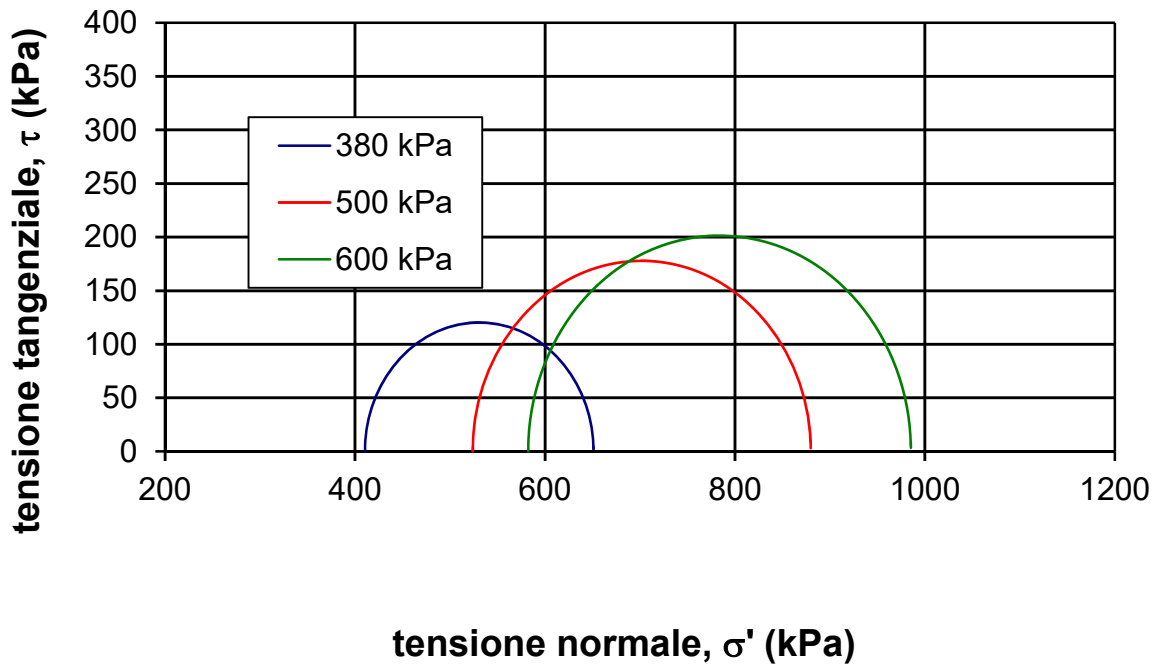
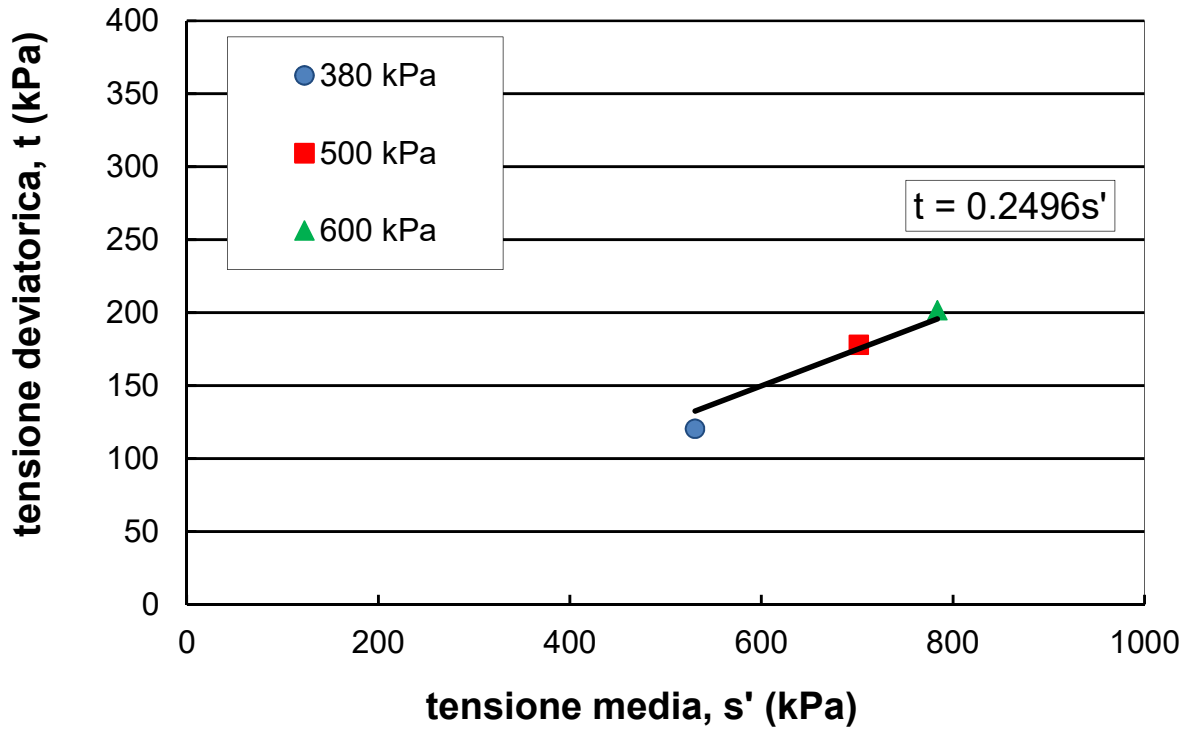

Prova Triassiale CIU SNME01-C3

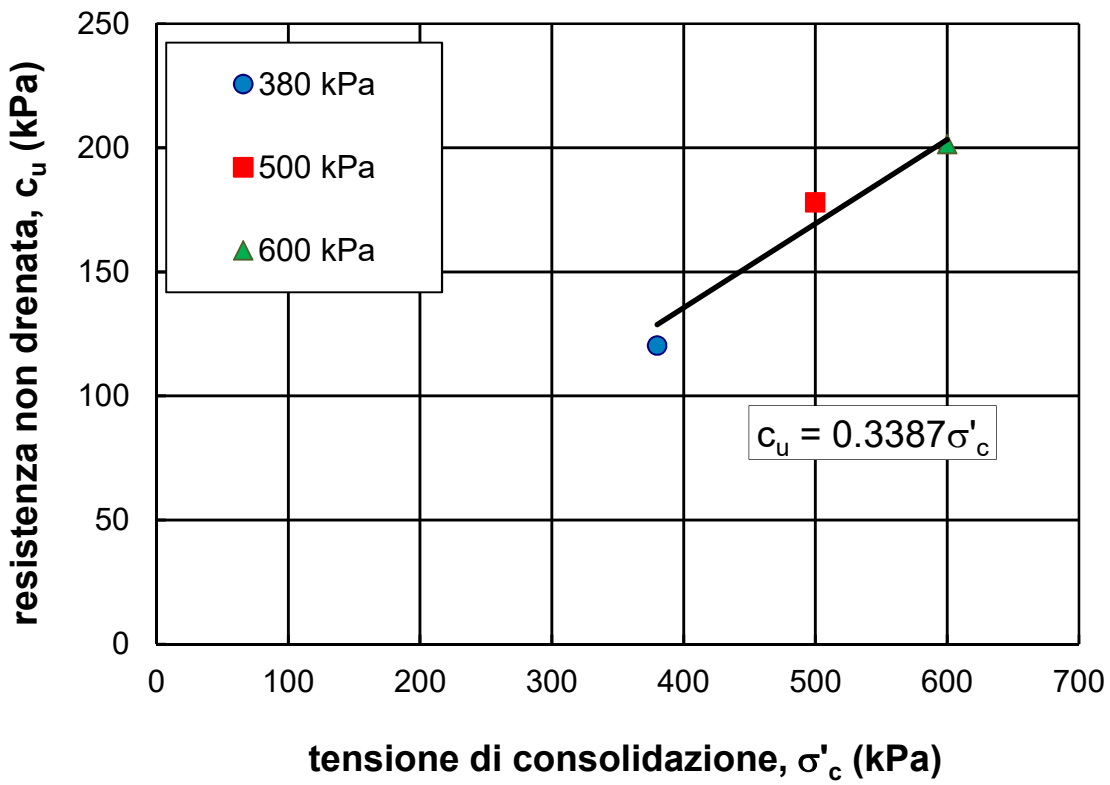
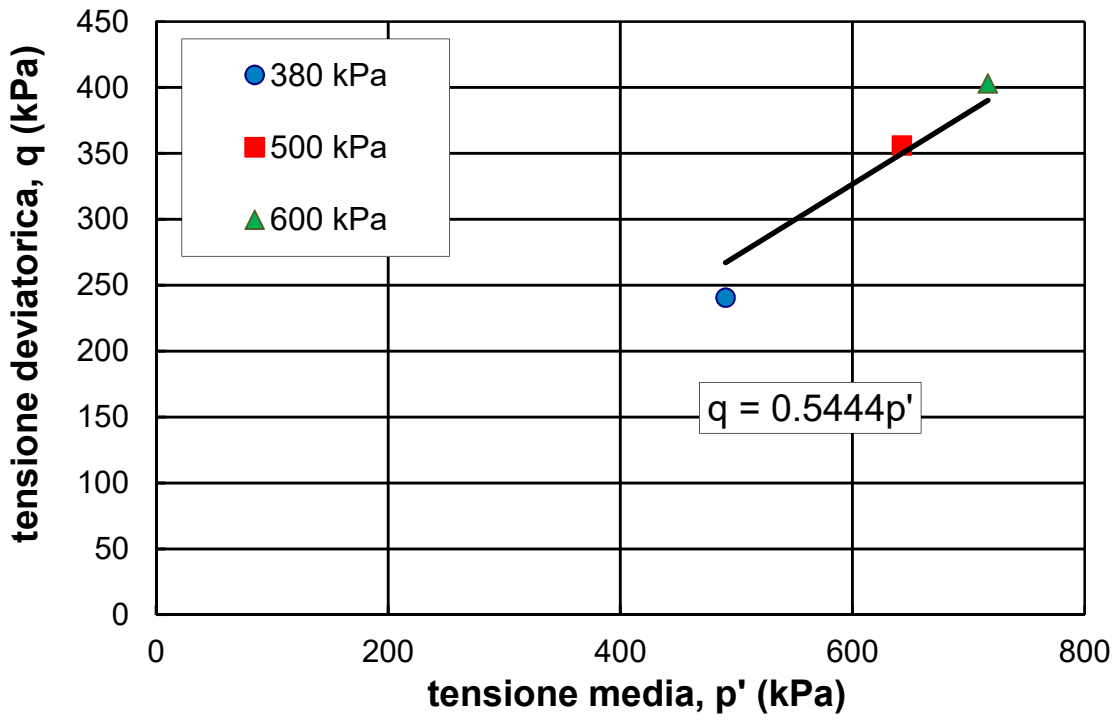



<u>Committente</u>	Consorzio HirpiniaAV
<u>Indagine</u>	I lotto funzionale Apice-Hirpinia
<u>Sondaggio</u>	SNME01
<u>Campione</u>	C3
<u>Profondità</u>	17.80 ÷ 18.40 m
<u>Data apertura</u>	05/11/19
<u>Operatore</u>	

Prova di TAGLIO TORSIONALE

Dati iniziali								
D (mm)	H (mm)	V (cm ³)	γ (kN/m ³)	w (%)	γ_s (kN/m ³)	e (/)	S _r (%)	p' (kPa)
35.30	71.98	70.41	21.47	18.84	27.06	0.498	1.00	358

Dati fine consolidazione								
D (mm)	H (mm)	V (cm ³)	γ (kN/m ³)	w (%)	γ_d (kN/m ³)	e (/)	S _r (%)	p' (kPa)
35.13	71.83	69.61	21.61	18.223	18.3	0.480	1.00	358

TAGLIO TORSIONALE					
γ (%)	G (MPa)	D (%)	f _r (Hz)	G/G ₀ (/)	Du/p'
3.46E-04	146.86	3.2	0.5	1.00	
5.17E-04	146.86	2.85	0.5	1.00	0.00
7.82E-04	144.82	2.94	0.5	0.99	0.00
1.16E-03	144.82	2.87	0.5	0.99	0.00
1.66E-03	145.84	3.46	0.5	0.99	0.00
2.49E-03	144.82	3.21	0.5	0.99	0.00
3.77E-03	143.80	3.16	0.5	0.98	0.00
4.95E-03	140.74	3.6	0.5	0.96	0.00
5.10E-03	140.74	3.47	0.5	0.96	0.00
6.82E-03	138.70	3.59	0.5	0.94	0.00
1.19E-02	132.59	4.39	0.5	0.90	0.00
1.60E-02	126.47	5.17	0.5	0.86	0.00
2.28E-02	116.27	6.51	0.5	0.79	0.00
3.26E-02	105.05	8.19	0.5	0.72	0.01
4.52E-02	94.17	9.84	0.5	0.64	0.01
4.60E-02	92.27	10.14	0.5	0.63	0.01
6.98E-02	80.59	12.24	0.5	0.55	0.01
1.01E-01	68.27	15.03	0.5	0.46	0.01
1.14E-01	61.10	15.13	0.5	0.42	0.01
1.36E-01	56.09	16.11	0.5	0.38	0.02
1.93E-01	45.21	21.38	0.5	0.31	0.02
2.72E-01	33.66	29.47	0.5	0.23	0.02
5.46E-01	19.99	28.4	0.5	0.14	0.02



Università degli Studi di Napoli Federico II

Dipartimento di Ingegneria Civile, Edile ed Ambientale

Laboratorio di Geotecnica

<u>Committente</u>	Consorzio HirpiniaAV
<u>Indagine</u>	I lotto funzionale Apice-Hirpinia
<u>Sondaggio</u>	SNME01
<u>Campione</u>	C3
<u>Profondità</u>	17.80 ÷ 18.40 m
<u>Data apertura</u>	05/11/19
<u>Operatore</u>	

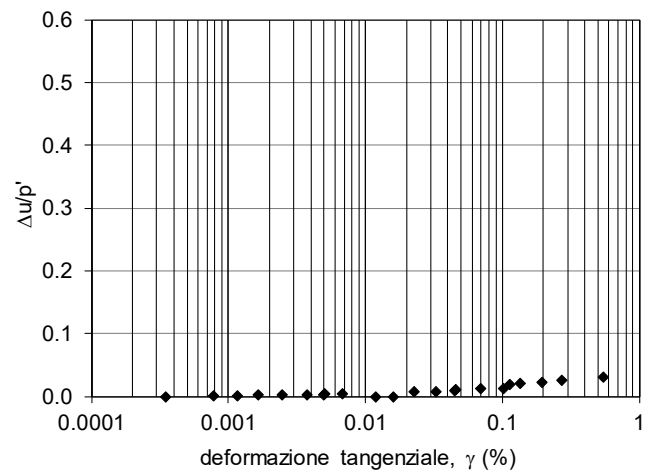
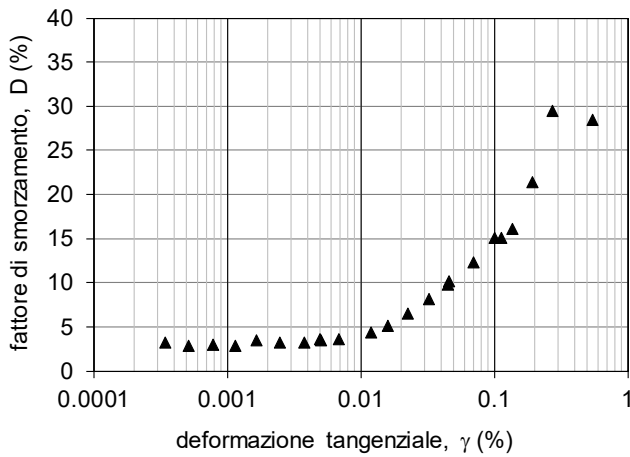
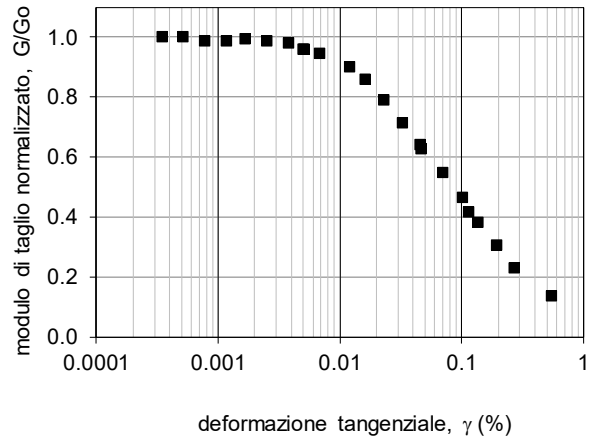
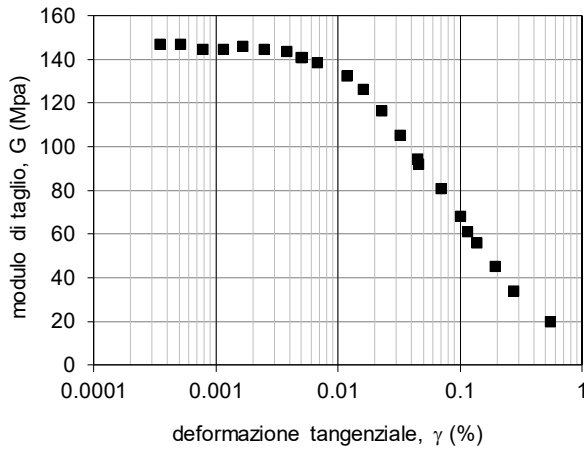



<u>Committente</u>	Consorzio HirpiniaAV
<u>Indagine</u>	I lotto funzionale Apice-Hirpinia
<u>Sondaggio</u>	SNME01
<u>Campione</u>	C3
<u>Profondità</u>	17.80 ÷ 18.40 m
<u>Data apertura</u>	05/11/19
<u>Operatore</u>	

APPENDICE

1. L'attrezzatura sperimentale per prove di taglio torsionale

L'apparecchiatura utilizzata è la cella di taglio torsionale THOR (Figura A.1), progettata e realizzata presso l'Università di Napoli Federico II (d'Onofrio, 1996) sulla base del prototipo originario di colonna risonante 'fixed-free' messo a punto presso l'Università del Texas di Austin (Isenhower, 1979; Ni, 1987). Le caratteristiche tecniche dell'apparecchiatura sono dettagliate da d'Onofrio et al. (1999). In Tabella A.1 sono sintetizzate le principali caratteristiche del sistema, ed in Figura A.2 uno schema della catena strumentale per il controllo e l'acquisizione.

Tipo di prova		Colonna risonante / Taglio torsionale
Nome dell'apparecchiatura		THOR
Provino	Diametro esterno	36mm
	Altezza	72mm
	Accuratezza nella misura delle dimensioni e del peso del provino	0.1 mm, 0.1gr
	Metodo di preparazione del provino	Fustellamento
	Saturazione	In cella via back-pressure
	Test di B	B > 0.95 mediando i valori ottenuti incrementando e decrementando la pressione di cella
	Contatto tra provino e apparecchiatura	Piastra rugosa avvitata nella testa di carico e pietra porosa di carburo di silicio avvitata al piedistallo
Sistema di applicazione dei carichi torcenti	Tipo	Motore elettromagnetico
Accuratezza del sistema di controllo	Pressione di cella	40 Pa attraverso convertitore E/P
	Contropressione	Senza controllo
	Sistema di applicazione dei carichi torcenti	Controllo in corrente risoluzione $1.6 \cdot 10^{-5}$ Nm (2 Pa per il provino \varnothing 36 mm) Fondo scala 5 Nm Non c'è effetto della forza elettromotrice indotta
Tipo di trasduttori utilizzati	Pressione di cella	Sensore di pressione di elevate prestazioni con membrana al silicone
	Contropressione	Trasduttore miniaturizzato con diaframma al silicone
	Pressione neutra	Trasduttore miniaturizzato con diaframma al silicone
	Coppia torcente	Cella torsionale a strain-gage
	Spostamenti assiali	LVDT in corrente continua
	Variazioni di volume	Trasduttore differenziale di pressione/ volumometro
	Accelerazioni	Accelerometro piezoelettrico
	Rotazioni	Laser /Proximitor
Accuratezza delle misure	Pressione di cella	1.5 Pa
	Contropressione	0.7 Pa
	Pressione interstiziale	0.7 Pa
	Coppia torcente	$6 \cdot 10^{-3}$ Nm
	Spostamenti assiali	1 μ m
	Variazioni di volume	0.0014 cm ³
	Rotazioni	$2.5 \cdot 10^{-7}$ rad (prox)

Tabella A.1. Principali caratteristiche della cella di taglio torsionale THOR.



Università degli Studi di Napoli Federico II
Dipartimento di Ingegneria Civile, Edile ed Ambientale
Laboratorio di Geotecnica

<u>Committente</u>	Consorzio HirpiniaAV
<u>Indagine</u>	I lotto funzionale Apice-Hirpinia
<u>Sondaggio</u>	SNME01
<u>Campione</u>	C3
<u>Profondità</u>	17.80 ÷ 18.40 m
<u>Data apertura</u>	05/11/19
<u>Operatore</u>	



Figura A.1. L'apparecchiatura di taglio torsionale THOR.



Figura A.2. Diagramma schematico del sistema di controllo e acquisizione di THOR



<u>Committente</u>	Consorzio HirpiniaAV
<u>Indagine</u>	I lotto funzionale Apice-Hirpinia
<u>Sondaggio</u>	SNME01
<u>Campione</u>	C3
<u>Profondità</u>	17.80 ÷ 18.40 m
<u>Data apertura</u>	05/11/19
<u>Operatore</u>	

2. Procedure sperimentali per le prove RC e CTS

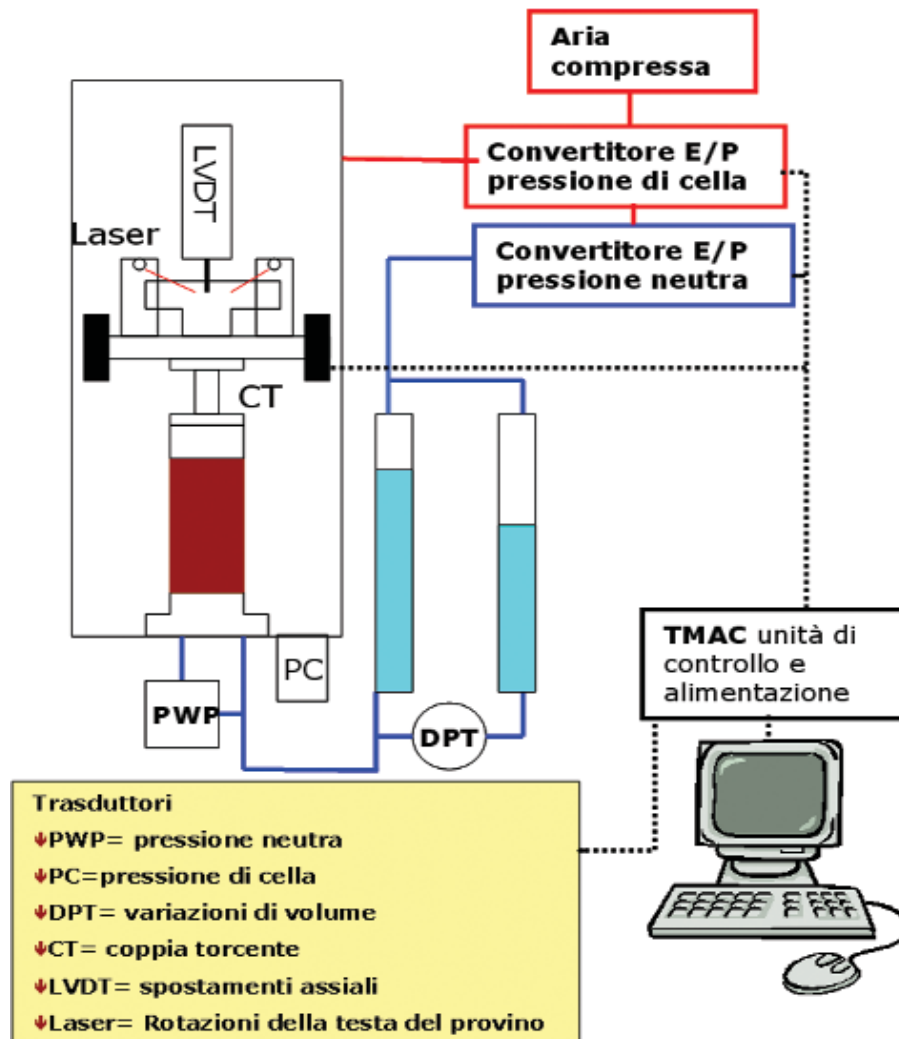
Ciascun provino è stato sottoposto ad una prima fase di applicazione della sollecitazione sferica per ricondurre il provino alla tensione efficace stimata agente in sito.

Al termine di questa fase è stato poi applicato il carico torsionale $M(t)$, avente caratteristiche diverse in funzione del tipo di prova. In particolare, in relazione alla frequenza con la quale vengono fatte variare le sollecitazioni nel tempo, è possibile distinguere due tipi di prova: prove «cicliche» (torsione ciclica, CTS) e prove «dinamiche» propriamente dette (colonna risonante, RC).

I criteri di interpretazione delle prove in termini di rigidità e smorzamento sono variabili a seconda delle caratteristiche della sollecitazione torsionale applicata. Infatti, nelle prove TS l'effetto delle forze di inerzia è trascurabile e quindi l'interpretazione è di tipo «quasi statico», mentre per le prove RC è necessario fare riferimento a modelli d'analisi dinamici. I criteri descritti in seguito sono quelli pressoché universalmente adottati per l'interpretazione delle prove RC e CTS, conformi alle norme ASTM (ASTM D4015/92). Presso il DIGA sono state messe a punto, e vengono normalmente utilizzate, procedure di interpretazione più complesse, che si avvalgono della completa automazione e digitalizzazione delle prove. Queste procedure, ampiamente descritte altrove (Papa et al., 1988; Silvestri, 1991, d'Onofrio, 1996), tra l'altro consentono di aumentare l'affidabilità dei risultati anche quando il livello di deformazioni indagato è basso e quindi si è in presenza di un rapporto segnale/rumore non elevato. Per approfondimenti si rimanda a Silvestri (1991).

2.1 Prove di colonna risonante (RC)

Durante una prova di colonna risonante (Figura A.3) il provino è sottoposto ad una sollecitazione torsionale di ampiezza M costante e frequenza f variabile nel tempo:

$$M(t) = M \sin[2\pi ft]$$

Nell'attrezzatura utilizzata, l'estremità superiore del provino è libera, mentre la base è rigidamente vincolata al piedistallo fisso; in tal modo lo schema dinamico di riferimento è del tipo «a base fissa» o «fixed-free» (Woods, 1978).

Durante la prova, viene registrata la vibrazione della testa del provino in termini di rotazione, θ , rilevata a seconda dei casi da una coppia di sensori laser oppure da due coppie di trasduttori di prossimità. Tale misura viene convertita in deformazioni tangenziali, γ , mediante le opportune costanti di taratura (d'Onofrio, 1996). La risposta del provino risulta in ogni istante isofrequenziale con la sollecitazione, mentre l'ampiezza (θ o γ) varia in relazione alla frequenza, ed attinge il valore massimo quando vengono raggiunte le cosiddette "condizioni di risonanza" ($f = f_R$).

Il modulo tangenziale G viene dedotto dalla misura della velocità delle onde di taglio, V_s , ottenuta analizzando la risposta del sistema composto da provino e dispositivo di carico torsionale, sulla base di classici modelli teorici di vibrazione torsionale di solidi cilindrici (Richart et al, 1970). Dalla conoscenza delle caratteristiche fisico-geometriche del sistema, V_s e G si ricavano applicando le espressioni:

$$V_s = \frac{2\pi f L}{\beta}$$

$$G = \rho V_s^2$$

dove L indica l'altezza del provino e ρ la densità del terreno. La costante adimensionale β è funzione dell'inerzia polare di massa del provino, I , e di quella del sistema di eccitazione, I_0 , secondo l'equazione:

$$\frac{I}{I_0} = \beta \tan \beta$$

Dalla curva di risposta è possibile anche ricavare il fattore di smorzamento D , individuando i valori di frequenza (f_1, f_2) corrispondenti ad un'ampiezza di vibrazione pari a $\gamma_{\max}/\sqrt{2}$ (metodo della "semibanda di potenza"):

$$D_{hp} = \frac{f_2 - f_1}{2 f_R}$$

A causa della non linearità e della degradazione ciclica, questo criterio non sempre fornisce una valutazione attendibile del fattore di smorzamento D . In casi del genere si può, in alternativa, ricorrere al metodo basato sull'espressione analitica del



<u>Committente</u>	Consorzio HirpiniaAV
<u>Indagine</u>	I lotto funzionale Apice-Hirpinia
<u>Sondaggio</u>	SNME01
<u>Campione</u>	C3
<u>Profondità</u>	17.80 ÷ 18.40 m
<u>Data apertura</u>	05/11/19
<u>Operatore</u>	

fattore di risonanza (metodo del fattore di risonanza), cioè il rapporto tra il valore di picco, γ_{\max} , della curva di risposta $\gamma(f)$ e la rotazione statica corrispondente ad una coppia di eguale ampiezza M. Da esso si ricava D, una volta noti le ampiezze M e γ_{\max} , ed il valore di G già calcolato, con l'espressione seguente:

$$D_{rf} = \frac{M_0 \bar{R}}{2G\gamma_{\max}}$$

Questo metodo appare in genere più attendibile di quello precedente, perché meno sensibile agli effetti della non linearità e della degradazione ciclica del terreno.



Figura A.3: Interpretazione delle prove di colonna risonante.



<u>Committente</u>	Consorzio HirpiniaAV
<u>Indagine</u>	I lotto funzionale Apice-Hirpinia
<u>Sondaggio</u>	SNME01
<u>Campione</u>	C3
<u>Profondità</u>	17.80 ÷ 18.40 m
<u>Data apertura</u>	05/11/19
<u>Operatore</u>	

2.2 Prova di torsione ciclica (CTS)

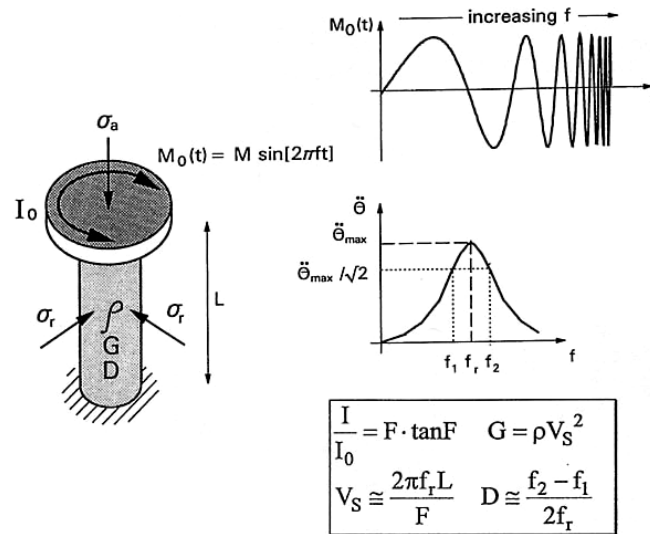
Durante una prova di torsione ciclica (Figura A.4), il provino viene sottoposto ad un momento torcente $M(t)$ variabile nel tempo con legge sinusoidale (di ampiezza e frequenza costanti) e si misura la rotazione della testa $\theta(t)$.

Le tracce temporali rappresentative di momenti e rotazioni vengono tradotte in termini di andamenti $\tau(t)$ e $\gamma(t)$, mediante le opportune costanti di taratura ed assumendo alcune ipotesi semplificative sulla distribuzione dello stato tensio-deformativo all'interno del provino.

Per ciascun ciclo di carico si individuano quindi i valori di picco della tensione e della deformazione tangenziali (τ_{max} e γ_{max}), e l'andamento del ciclo di isteresi risultante dall'accoppiamento di $\tau(t)$ e $\gamma(t)$.

I valori di G e D vengono calcolati utilizzando le relazioni:

$$G = \frac{\tau_{pp}}{\gamma_{pp}} \qquad D = \frac{W_d}{4\pi W_s}$$

Per l'interpretazione dei risultati relativi alle prove di torsione ciclica si è attribuita maggiore affidabilità a tecniche di regressione statistica ai bassi livelli di deformazione (adoperando una regressione sinusoidale, cfr. Papa et al., 1988); non appena i disturbi elettrici sono apparsi senz'altro trascurabili, si è ricorsi ai criteri ordinari (ampiezze picco-picco, area del ciclo di isteresi).



Figura A.4: Interpretazione delle prove di torsione ciclica.



Università degli Studi di Napoli Federico II
Dipartimento di Ingegneria Civile, Edile ed Ambientale
Laboratorio di Geotecnica

<u>Committente</u>	Consorzio HirpiniaAV
<u>Indagine</u>	I lotto funzionale Apice-Hirpinia
<u>Sondaggio</u>	SNME01
<u>Campione</u>	C3
<u>Profondità</u>	17.80 ÷ 18.40 m
<u>Data apertura</u>	05/11/19
<u>Operatore</u>	

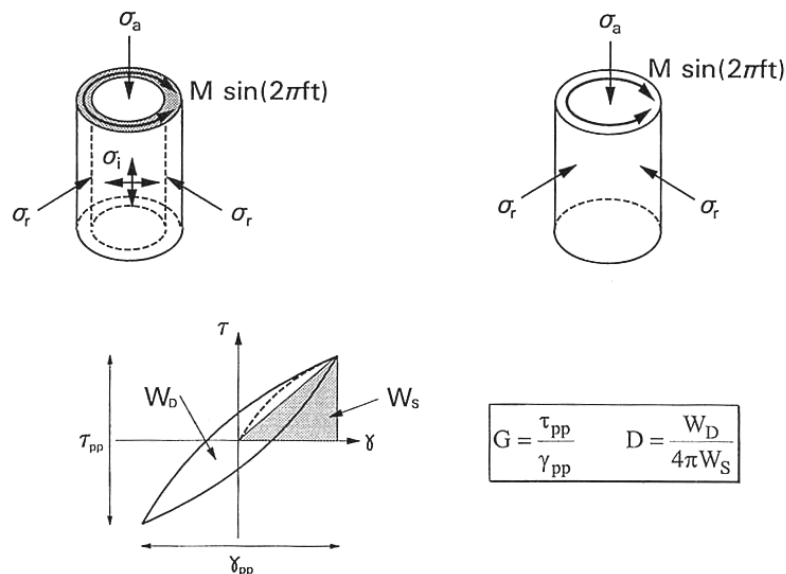
Riferimenti

AGI (1994) - *Raccomandazioni sulle prove geotecniche di laboratorio*

ASTM D422/90 - *Standard Test Method for particle-size analysis of soils.*

ASTM D4318 - *Standard Test Methods for liquid limit, plastic limit, and plasticity index of Soils.*

ASTM D2435/96 - *Standard Test Methods for one-dimensional consolidation properties of soils using incremental loading.*

ASTM D4015/92 - *Standard Test Methods for modulus and damping of soils by Resonant-Column method.*

d'Onofrio A. (1996) – *Comportamento meccanico dell'argilla di Vallericca in condizioni lontane dalla rottura* – Tesi di dottorato in Ingegneria Geotecnica, Università degli Studi di Napoli.

d'Onofrio A., Silvestri F., Vinale F. (1999) - *A new torsional shear device* - ASTM Geotechnical Testing Journal, Vol 22-2 pp.107-117.

Isenhower W.M. (1979) - *Torsional Simple Shear/Resonant Column properties of San Francisco Bay Mud* - M.S. Thesis, The University of Texas at Austin.

Ni S. H. (1987) *Dynamic properties of sand under true triaxial stress states from Resonant Column/Torsional Shear tests* - Ph. D. dissertation, The University of Texas at Austin.

Papa V., Silvestri F., Vinale F. (1988) - *Recenti sviluppi e prospettive nelle tecniche di interpretazione di prove dinamiche di taglio semplice* - Atti del Convegno del Gruppo Nazionale di Coordinamento per gli Studi di Ingegneria Geotecnica, Monselice.

Richart F.E., Hall J.R., Woods R.D. (1970) - *Vibrations of soils and foundations* - Prentice-Hall Inc., Englewood Cliffs, New Jersey.

Silvestri F. (1991) - *Analisi del comportamento dei terreni naturali in prove cicliche e dinamiche di taglio torsionale* - Tesi di Dottorato in Ingegneria Geotecnica, Università degli Studi di Napoli.

Woods R.D. (1978) - *Measurement of dynamic soil properties* - Proc. "Geotechnical Engineering Division Specialty Conference on Earthquake Engineering and Soil Dynamics", ASCE, Pasadena (California).

Il responsabile della sperimentazione
Prof. Ing. Anna d'Onofrio



<u>Committente</u>	Consorzio HirpiniaAV
<u>Indagine</u>	I lotto funzionale Apice-Hirpinia
<u>Sondaggio</u>	SNME01
<u>Campione</u>	C7
<u>Profondità</u>	50.00 ÷ 50.70 m
<u>Data apertura</u>	25/11/19
<u>Operatore</u>	Alfredo Pozzo

Diametro (mm):	80
Lunghezza (mm):	680
Data di apertura:	25/11/2019

Stato del Campione	Indisturbato	x
	Parzialmente Rimaneggiato	
	Rimaneggiato	

Descrizione: Alternanza di breccie calcaree marnose, ghiaie in matrice argillosa e argille scagliettate con evidenti giaciture prevalenti. Presenza di elementi litoidi marnosi di diametro pari a quello della fustella

Colore	Rosso, verde				
Plasticità	<input type="checkbox"/> Non Plastico	<input type="checkbox"/> Bassa	<input type="checkbox"/> Media alta	<input checked="" type="checkbox"/> Elevata	
Addensamento (Terreni granulari)	<input type="checkbox"/> Molto sciolto ($D_r=0.0\div0.2$)	<input type="checkbox"/> Sciolto ($D_r=0.2\div0.4$)	<input type="checkbox"/> Medio ($D_r=0.4\div0.6$)	<input type="checkbox"/> Denso ($D_r=0.6\div0.8$)	<input type="checkbox"/> Molto denso ($D_r=0.8\div1.0$)
Consistenza (Terreni coesivi)	<input type="checkbox"/> Molto molle ($I_c < 0.0$)	<input type="checkbox"/> Molle ($I_c=0.0\div0.5$)	<input type="checkbox"/> Media ($I_c=0.5\div1.0$)	<input checked="" type="checkbox"/> Consistente ($I_c > 1.0$)	<input type="checkbox"/> Molto consist. ($I_c >> 1.0$)
Grado di umidità	<input type="checkbox"/> Asciutto	<input type="checkbox"/> Poco Umido	<input checked="" type="checkbox"/> Umido	<input type="checkbox"/> Molto Umido	
Alterazione	<input checked="" type="checkbox"/> Assente	<input checked="" type="checkbox"/> Debole	<input type="checkbox"/> Media	<input type="checkbox"/> Elevata	
Struttura	<input type="checkbox"/> Omogenea	<input type="checkbox"/> Stratificata	<input type="checkbox"/> Scagliosa	<input type="checkbox"/> Laminata	<input checked="" type="checkbox"/> Caotica
Fratturazione	<input type="checkbox"/> Assente	<input type="checkbox"/> Moderata	<input type="checkbox"/> Elevata		
Cementazione	<input type="checkbox"/> Assente	<input type="checkbox"/> Debole	<input type="checkbox"/> Media	<input type="checkbox"/> Elevata	

Proprietà fisiche			Proprietà meccaniche	
n, γ, w	X		Compressione uniaassiale	
Analisi granulometrica	X		TX-UU	
Limiti	X		TX-CIU	
CaCO ₃			TX-CID	
Sostanze organiche			TX-Ciclica	
Peso specifico del solido			Taglio anulare	
Proctor			Taglio diretto	
CBR			RC TS	
Altro _____			Altro _____	

Non è stato possibile confezionare i provini



Committente	Consorzio HirpiniaAV
Indagine	I lotto funzionale Apice-Hirpinia
Sondaggio	SNME01
Campione	C7
Profondità	50.00-50.40
Data	25/11/2019
Operatore	Alfredo Ponzo

LIMITE DI PLASTICITA'				
pesafiltro n°	Tara	Peso lordo umido (P _u)	Peso lordo secco (P _s)	Contenuto d'acqua (w)
[-]	[gr]	[gr]	[gr]	[-]
20	15.54	64.35	52.36	0.326
w_P				0.326

LIMITE DI LIQUIDITA' (Metodo di Casagrande ASTM)					
Pesafiltro n°	N° colpi (N)	Tara (P _c)	Peso lordo umido (P _u)	Peso lordo secco (P _s)	Contenuto d'acqua (w)
[-]	[-]	[g]	[g]	[g]	[g]
175	19	11.61	47.24	31.18	0.821
165	35	12.05	43.06	29.44	0.783
81	12	11.42	35.21	24.23	0.857
25	Limite di liquidità ASTM (w_L)				0.804

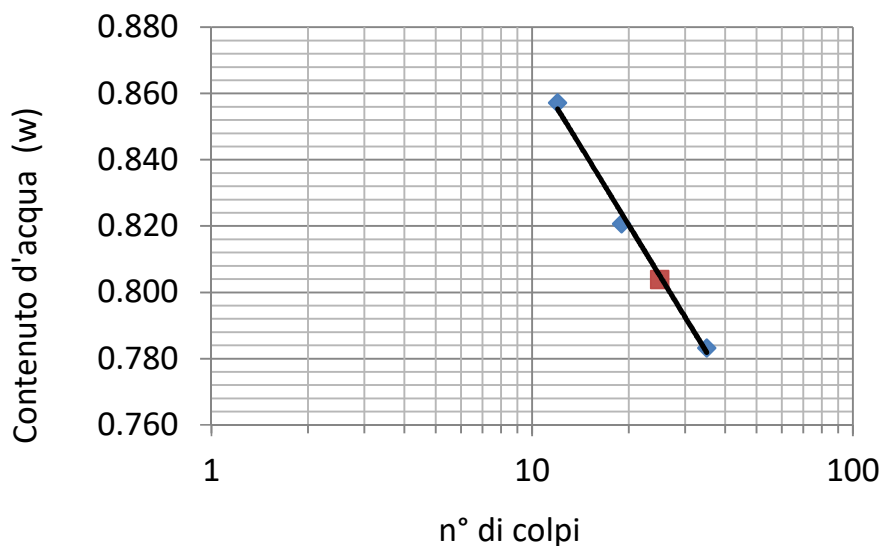

Indice di plasticità (I _p)	Frazione argillosa CF (d < 2 μm)	Indice di attività (I _A)
[%]	[%]	[-]
47.82	31.000	1.54

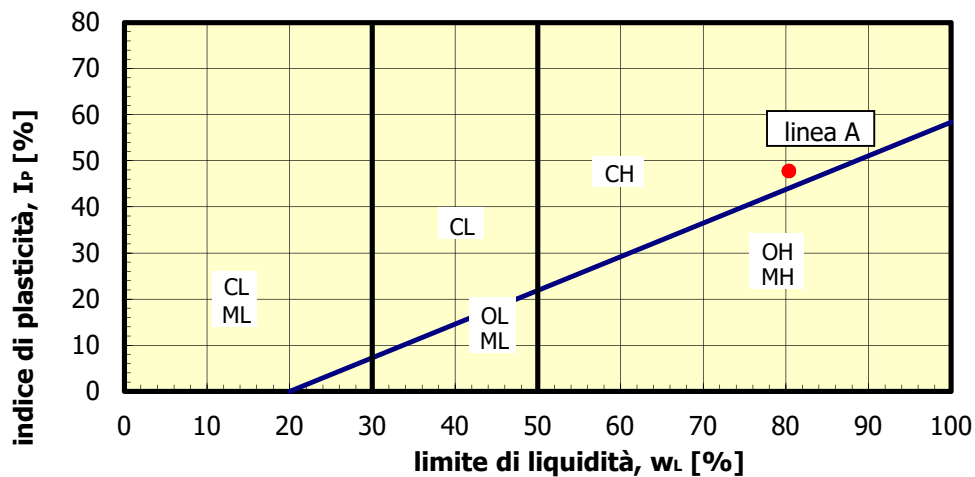

ML	Limi inorganici da bassa a media plasticità	M = limi
CL	Argille inorganiche da bassa a media plasticità	C = argille
OL	Limi e argille organiche di bassa plasticità	O = sostanze organiche
MH	Limi inorganici di alta plasticità	L = bassa plasticità
CH	Argille inorganiche di alta plasticità	H = alta plasticità
OH	Argille organiche da media ad alta plasticità	

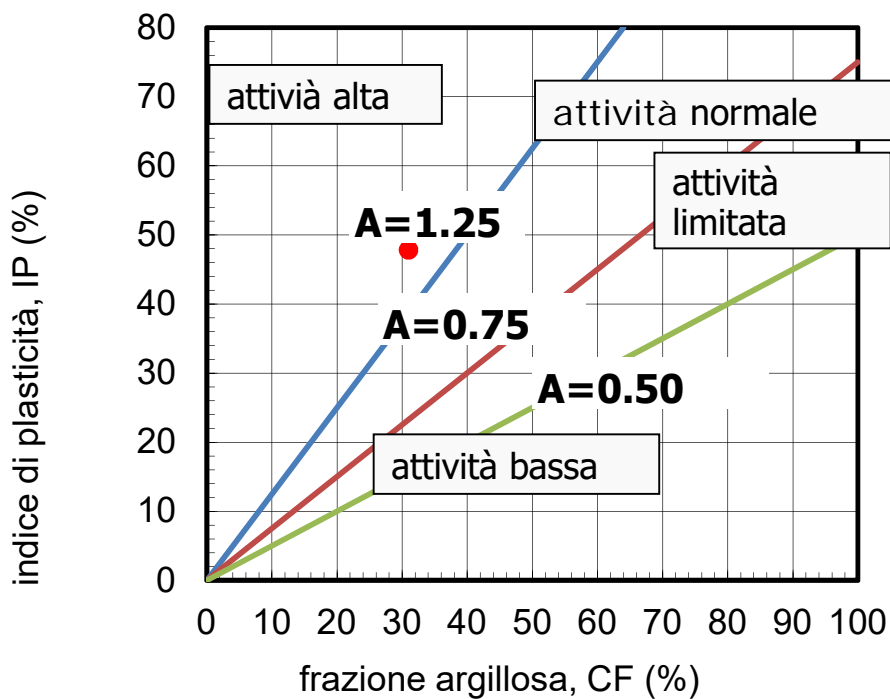

CONSISTENZA TERRENO A GRANA FINE		
w_L	I_p	I_c
[-]	[-]	[-]
80.380	47.82	1.68
COMPATTEZZA TERRENO A GRANA GROSSA		
e_{max}	e_{min}	D_r
[-]	[-]	[-]

80.38

	CF	I_p	w_L	I_p
1.25	0	0	20	0
	64	80	100	58.4
0.75	0	0		
	100	75	30	0
0.50			30	100
	0	0		
	100	50	50	0
			50	100



Università degli Studi di Napoli
 Dipartimento di Ingegneria Civile, Edile e Ambientale
 Laboratorio di Geotecnica

Committente	Consorzio HirpiniaAV
Indagine	I lotto funzionale Apice-Hirpinia
Sondaggio	SNME01
Campione	C7
Profondità	50.00 ±50.70 m
Data	25/11/2019
Operatore	Alfredo Ponzo

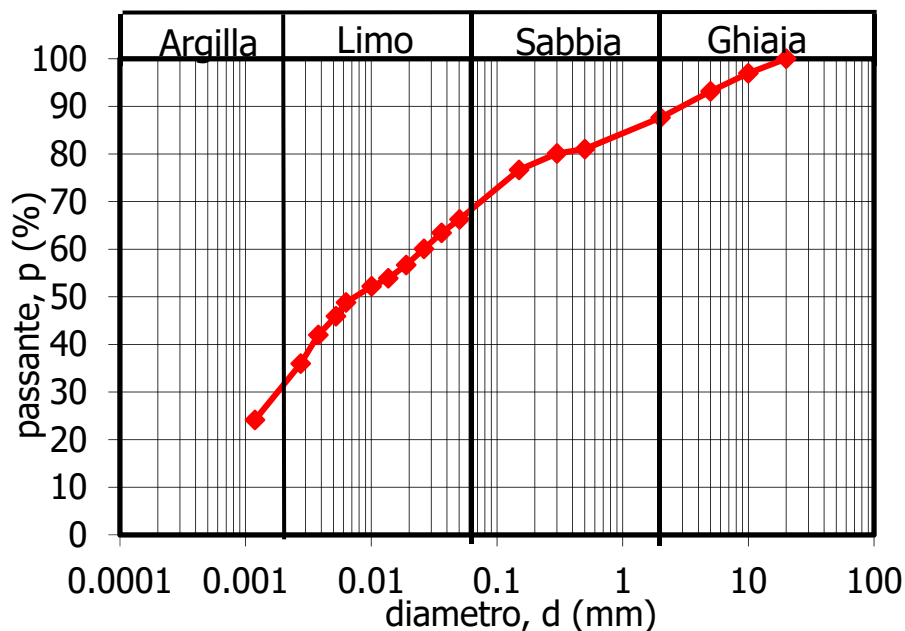

Curva granulometrica	
diametro (mm)	passante (%)
20.00	100.00
10.00	96.96
5.00	93.17
2.00	87.64
0.50	81.03
0.30	80.11
0.15	76.67
0.05	66.27
0.04	63.45
0.03	60.08
0.02	56.70
0.014	53.89
0.010	52.20
0.006	48.82
0.005	45.93
0.004	41.99
0.003	35.96
0.001	24.15

LIMO CON ARGILLA SABBIOSO, GHAIOSO

peso secco totale (g)	peso secco sediment. (g)
55.73	55.73

STACCIATURA			SEDIMENTAZIONE		
d (mm)	peso trattenuto (g)	peso passante (g)	tempo (min)	temperatura (°C)	lettura areometro (g/cm ³)
0.50	0.00	45.16		23.25	
0.30	0.63	44.65	0.5	23.25	1.0305
0.15	3.00	42.73	1	23.25	1.02925
			2	23.25	1.02775
			4	23.25	1.02625
			8	23.25	1.025
			15	23.25	1.02425
			40	23.25	1.02275
			60	23	1.0215
			120	23	1.01975
			240	23.5	1.017
			1440	23.5	1.01175

Gs= 2.825

%<0.075mm	%ghiaia	%sabbia	%limo	%argilla	D _{max} (mm)	D ₆₀ (mm)	D ₁₀ (mm)
70	12	20	37	31	20.00	0.0300	

Normativa di riferimento : ASTM 422/90

il responsabile della sperimentazione
 prof. Ina Anna d'Onofrio

Japan 1945



Università degli Studi di Napoli
Dipartimento di Ingegneria Civile, Edile e Ambientale
Laboratorio di Geotecnica

Committente	Consorzio HirpiniaAV
Indagine	Apice-Hirpinia
Sondaggio	SNME01
Campione	C7
Profondità	50.00-50.40
Data	25/11/2019
Operatore	Alfredo Ponzo

Peso specifico del solido	
Peso specifico dell'acqua (γ_w) (g/cm ³)	1.000
picnometro n°	18.000
Peso picnometro (P_p) (g)	59.76
Peso picnometro + acqua (P_{pw}) (g)	158.160
Volume picnometro (V_p) (cm ³)	98.4
Peso picnometro + terreno (P_{ps}) (g)	79.17
Peso terreno (P_s)	19.41
Peso picnometro + terreno + acqua (P_{psw}) (g)	170.700
Volume acqua aggiunta (V_w) (cm ³)	91.53
Volume terreno (V_s) (cm ³)	6.870
Peso specifico del terreno (γ_s) (kN/m ³)	27.705

Caratteristiche Fisiche Generali		
pesafiltro n°	38	198
Peso contenitore (P_c) (g)	8.76	12.28
Diametro (D) (mm)		
Altezza (H) (mm)		
Volume (V) (cm ³)		
Peso lordo umido (P_u) (g)	36.73	44.32
Peso lordo secco (P_s) (g)	32.66	40.22
Contenuto d'acqua (w)	0.17	0.15
Peso umido unità di volume (γ) (kN/m ³)		
Peso secco unità di volume (γ_d) (kN/m ³)		
Peso specifico del solido (γ_s) (kN/m ³)		
Porosità (n)		
Indice dei vuoti (e)		
Grado di Saturazione (S_r)		

il responsabile della sperimentazione

Anna d'Onofrio
prof. ing. Anna d'Onofrio



Università degli Studi di Napoli Federico II
 Dipartimento di Ingegneria Civile, Edile ed Ambientale
 Laboratorio di Geotecnica

<u>Committente</u>	Consorzio HirpiniaAV
<u>Indagine</u>	I lotto funzionale Apice-Hirpinia
<u>Sondaggio</u>	SNME01
<u>Campione</u>	C12
<u>Profondità</u>	78.50 ÷ 79.00 m
<u>Data apertura</u>	09/12/19
<u>Operatore</u>	Alfredo Pozzo

Diametro (mm):	80
Lunghezza (mm):	500
Data di apertura:	09/12/2019

Stato del Campione	Indisturbato	x
	Parzialmente Rimaneggiato	
	Rimaneggiato	

Descrizione: Argilla varicolore scagliosa con presenza di fratture lungo superfici inclinate di circa 30°					
Colore	Rosso, verde, grigia				
Plasticità	<input type="checkbox"/> Non Plastico	<input type="checkbox"/> Bassa	<input type="checkbox"/> Media alta	<input checked="" type="checkbox"/> Elevata	
Addensamento (Terreni granulari)	<input type="checkbox"/> Molto sciolto (D _r =0.0÷0.2)	<input type="checkbox"/> Sciolto (D _r =0.2÷0.4)	<input type="checkbox"/> Medio (D _r =0.4÷0.6)	<input type="checkbox"/> Denso (D _r =0.6÷0.8)	<input type="checkbox"/> Molto denso (D _r =0.8÷1.0)
Consistenza (Terreni coesivi)	<input type="checkbox"/> Molto molle (I _c <0.0)	<input type="checkbox"/> Molle (I _c =0.0÷0.5)	<input type="checkbox"/> Media (I _c =0.5÷1.0)	<input type="checkbox"/> Consistente (I _c >1.0)	<input checked="" type="checkbox"/> Molto consist. (I _c >>1.0)
Grado di umidità	<input type="checkbox"/> Asciutto	<input type="checkbox"/> Poco Umido	<input checked="" type="checkbox"/> Umido	<input type="checkbox"/> Molto Umido	
Alterazione	<input checked="" type="checkbox"/> Assente	<input checked="" type="checkbox"/> Debole	<input type="checkbox"/> Media	<input type="checkbox"/> Elevata	
Struttura	<input type="checkbox"/> Omogenea	<input type="checkbox"/> Stratificata	<input checked="" type="checkbox"/> Scagliosa	<input type="checkbox"/> Laminata	<input type="checkbox"/> Caotica
Fratturazione	<input type="checkbox"/> Assente	<input checked="" type="checkbox"/> Moderata	<input type="checkbox"/> Elevata		
Cementazione	<input type="checkbox"/> Assente	<input type="checkbox"/> Debole	<input type="checkbox"/> Media	<input type="checkbox"/> Elevata	

Proprietà fisiche			Proprietà meccaniche	
n,γ,w	X		Compressione uniassiale	
Analisi granulometrica	X		TX-UU	
Limiti	X		TX-CIU	x
CaCO ₃			TX-CID	
Sostanze organiche			TX-Ciclica	
Peso specifico del solido	x		Taglio anulare	
Proctor			Taglio diretto	
CBR			RC TS	
Altro _____			Altro _____	



Università degli Studi di Napoli Federico II

Dipartimento di Ingegneria Civile, Edile ed Ambientale

Laboratorio di Geotecnica

<u>Committente</u>	Consorzio HirpiniaAV
<u>Indagine</u>	I lotto funzionale Apice-Hirpinia
<u>Sondaggio</u>	SNME01
<u>Campione</u>	C12
<u>Profondità</u>	78.50 ÷ 79.00 m
<u>Data apertura</u>	09/12/19
<u>Operatore</u>	Alfredo Ponso

FOTO CAMPIONE



FOTO CAMPIONE





Università degli Studi di Napoli
 Dipartimento di Ingegneria Civile, Edile e Ambientale
 Laboratorio di Geotecnica

Committente	Consorzio HirpiniaAV
Indagine	I lotto funzionale Apice-Hirpinia
Sondaggio	SNME01
Campione	C12
Profondità	78.50 +79.00 m
Data	16/12/2019
Operatore	Alfredo Ponzo

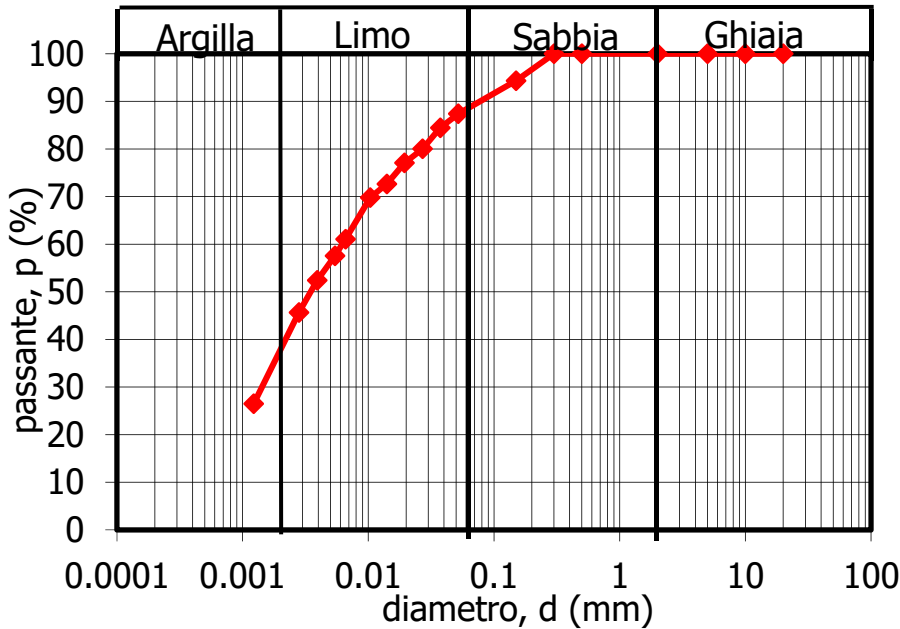

Curva granulometrica	
diametro (mm)	passante (%)
0.50	100.00
0.30	100.00
0.15	94.35
0.05	87.41
0.04	84.46
0.03	80.03
0.02	77.08
0.014	72.66
0.010	69.81
0.007	61.06
0.005	57.57
0.004	52.41
0.003	45.66
0.001	26.49

LIMO CON ARGILLA SABBIOSO

peso secco totale (g)	peso secco sediment. (g)
52.60	52.60

STACCIATURA			SEDIMENTAZIONE		
d (mm)	peso trattenuto (g)	peso passante (g)	tempo (min)	temperatura (°C)	lettura areometro (g/cm ³)
0.50	0.00	53.05		20.75	
0.30	0.00	53.05	0.5	21	1.031
0.15	3.00	50.05	1	21	1.03
			2	21	1.0285
			4	21	1.0275
			8	21	1.026
			15	21.25	1.025
			40	21.5	1.022
			60	22	1.02075
			120	22	1.019
			240	23.5	1.0165
			1440	23.5	1.01

G_s= 2.770

%<0.075mm	%ghiaia	%sabbia	%limo	%argilla	D _{max} (mm)	D ₆₀ (mm)	D ₁₀ (mm)
90	0	12	50	38	0.30	0.0060	

Normativa di riferimento : ASTM 422/90

il responsabile della sperimentazione
 prof. Ing. Anna d'Onofrio



Università degli Studi di Napoli Federico II
Dipartimento di Ingegneria Idraulica,
Geotecnica ed Ambientale

Prova Compressione Triassiale n.		Celle n.
Prova tipo	CU (consolidata non drenata)	
Committente	Consorzio Hirpinia AV	
Indagine	I lotto funzionale Apice-Hirpinia	
Sondaggio	SN_ME_01	
Campione	C12	
Profondità	78.50 ÷ 79.00 m	

Provino 1 Condizioni inizio prova			Provino 2 Condizioni inizio prova			Provino 3 Condizioni inizio prova		
altezza ho	mm	72.21	altezza ho	mm	71.96	altezza ho	mm	72.18
diámetro d	mm	35.62	diámetro d	mm	35.51	diámetro d	mm	35.61
peso umido iniziale	g	157.91	peso umido iniziale	g	154.43	peso umido iniziale	g	150.84
peso specifico γ_s	kN/m ³	27.19	peso specifico γ_s	kN/m ³	27.19	peso specifico γ_s	kN/m ³	27.19
Peso secco dell'udv γ_d	kN/m ³	18.57	Peso secco dell'udv γ_d	kN/m ³	17.81	Peso secco dell'udv γ_d	kN/m ³	17.28
Contenuto d'acqua w		0.159	Contenuto d'acqua w		0.182	Contenuto d'acqua w		0.190
Peso umido dell'udv γ	kN/m ³	21.53	Peso umido dell'udv γ	kN/m ³	21.05	Peso umido dell'udv γ	kN/m ³	20.56
Indice dei vuoti e		0.464	Indice dei vuoti e		0.527	Indice dei vuoti e		0.573
Grado di saturazione Sr		1.0	Grado di saturazione Sr		1.0	Grado di saturazione Sr		0.9
Condizioni fine prova			Condizioni fine prova			Condizioni fine prova		
Pesafiltro n° 20	g	20.70	Pesafiltro n° 17	g	20.75	Pesafiltro n° 23	g	20.90
Pf + prov. umido	g	178.79	Pf + prov. umido	g	173.86	Pf + prov. umido	g	172.17
Pf + prov.secco	g	156.89	Pf + prov.secco	g	151.39	Pf + prov.secco	g	147.66
Peso secco dell'udv γ_d	kN/m ³	18.75	Peso secco dell'udv γ_d	kN/m ³	18.19	Peso secco dell'udv γ_d	kN/m ³	17.53
Contenuto d'acqua w		0.161	Contenuto d'acqua w		0.172	Contenuto d'acqua w		0.193
Peso umido dell'udv γ	kN/m ³	21.76	Peso umido dell'udv γ	kN/m ³	21.32	Peso umido dell'udv γ	kN/m ³	20.92
Indice dei vuoti e		0.451	Indice dei vuoti e		0.495	Indice dei vuoti e		0.551
Grado di saturazione Sr		1.0	Grado di saturazione Sr		1.0	Grado di saturazione Sr		1.0

Consolidazione			Consolidazione			Consolidazione		
Pressione di cella σ_c	kPa	500	Pressione di cella σ_c	kPa	700	Pressione di cella σ_c	kPa	800
Contropressione u_0	kPa	200	Contropressione u_0	kPa	200	Contropressione u_0	kPa	200
Tensione effettiva $\sigma'c$	kPa	300	Tensione effettiva $\sigma'c$	kPa	500	Tensione effettiva $\sigma'c$	kPa	600
Data & ora	t	ΔV	Data & ora	t	ΔV	Data & ora	t	ΔV
(gg-hh-min)	(min)	(cmc)	(gg-hh-min)	(min)	(cmc)	(gg-hh-min)	(min)	(cmc)
	0	0		0	0		0	0
	0.13	0.106		0.13	0.051		0.13	0.072
	0.27	0.106		0.27	0.047		0.27	0.068
	0.52	0.106		0.52	0.051		0.52	0.072
	1	0.108		1	0.058		1	0.08
	2	0.110		2	0.062		2	0.083
	4	0.111		4	0.064		4	0.083
	8	0.117		8	0.068		8	0.085
	15	0.128		15	0.072		15	0.089
	30	0.145		30	0.088		30	0.1
	60	0.175		60	0.112		60	0.12
	120	0.227		120	0.153		120	0.17
	240	0.312		240	0.247		240	0.25
	480	0.458		480	0.380		480	0.375
	960	0.603		960	0.580		960	0.6
	1440	0.649		1440	0.742		1440	0.869
	2592	0.647		2593	0.770		2592	0.929
Volume finale V_c	(cmc)	71.27	Volume finale V_c	(cmc)	70.46	Volume finale V_c	(cmc)	70.92
Altezza finale h_c	(mm)	71.99	Altezza finale h_c	(mm)	71.70	Altezza finale h_c	(mm)	71.87
Area finale A_c	(cmq)	9.99	Area finale A_c	(cmq)	9.94	Area finale A_c	(cmq)	10.00
t100	(min)		t100	(min)		t100	(min)	

Laboratorio di Geotecnica

Prova Compressione Triassiale n.		Prova Compressione Triassiale n.		Prova Compressione Triassiale n.				
CIU (consolidata non drenata)		CIU (consolidata non drenata)		CIU (consolidata non drenata)				
Provino 1		Provino 2		Provino 3				
Velocità di prova (mm/min)	0.01	Velocità di prova (mm/min)	0.01	Velocità di prova (mm/min)	0.01			
tensione di confinamento (kPa)	300	tensione di confinamento (kPa)	500	tensione di confinamento (kPa)	600			
LVDT	cella di carico	Δu	LVDT	cella di carico	Δu	LVDT	cella di carico	Δu
δ (mm)	kg	(kPa)	δ (mm)	kg	(kPa)	δ (mm)	kg	(kPa)
0	0	0	0	0	0	0	0	0
0.003	0.269	0.600	0.001	1.224	0.300	0.002	0.567	0.481
0.007	0.424	1.200	0.002	2.335	0.800	0.003	3.655	0.998
0.011	0.655	1.900	0.004	3.238	1.300	0.004	6.614	2.245
0.016	0.810	2.400	0.008	3.914	1.800	0.009	9.197	3.493
0.021	0.926	2.900	0.011	4.655	2.400	0.010	11.214	4.740
0.024	1.118	3.500	0.015	5.138	3.000	0.016	13.671	6.237
0.029	1.234	4.000	0.019	5.734	3.600	0.020	15.497	7.484
0.034	1.465	4.600	0.022	6.185	4.200	0.023	17.640	8.732
0.039	1.581	5.300	0.026	6.620	4.800	0.027	19.278	9.979
0.042	1.813	5.900	0.031	6.958	5.400	0.030	21.104	10.977
0.047	1.889	6.200	0.034	7.296	6.000	0.034	22.616	12.225
0.052	2.005	6.800	0.038	7.667	6.600	0.037	23.687	12.973
0.057	2.160	7.200	0.042	7.972	7.300	0.043	24.570	13.721
0.060	2.275	7.800	0.046	8.294	8.000	0.046	25.137	14.220
0.065	2.429	8.300	0.050	8.552	8.700	0.052	25.577	14.719
0.069	2.507	8.800	0.056	8.875	9.300	0.056	25.830	15.218
0.073	2.661	9.200	0.060	9.165	10.000	0.062	26.208	15.468
0.078	2.737	9.700	0.064	9.341	10.600	0.066	26.396	15.468
0.083	2.853	10.100	0.068	9.647	11.300	0.072	26.585	15.717
0.086	3.008	10.500	0.072	9.825	11.900	0.076	26.901	15.967
0.091	3.047	10.900	0.077	10.147	12.600	0.080	27.027	16.216
0.096	3.239	11.400	0.081	10.275	13.200	0.086	27.342	16.216
0.100	3.278	11.800	0.085	10.630	13.800	0.090	27.468	16.715
0.104	3.432	12.100	0.090	10.743	14.500	0.096	27.782	16.965
0.109	3.432	12.400	0.094	10.953	15.100	0.102	27.846	16.965
0.114	3.586	12.800	0.099	11.162	15.800	0.105	28.034	17.214
0.119	3.663	13.000	0.103	11.307	16.400	0.110	28.223	17.214
0.122	3.779	13.500	0.107	11.516	17.100	0.115	28.349	17.214
0.127	3.857	14.000	0.111	11.676	17.700	0.120	28.539	17.713
0.132	3.933	14.300	0.115	11.870	18.400	0.125	28.539	17.713
0.137	4.049	14.600	0.121	12.047	19.000	0.130	28.853	17.963
0.142	4.126	14.900	0.125	12.112	19.600	0.135	28.915	17.963
0.145	4.165	15.200	0.129	12.354	20.300	0.140	29.042	17.963
0.150	4.318	15.600	0.133	12.450	20.900	0.146	29.168	18.212
0.155	4.357	15.900	0.138	12.676	21.600	0.150	29.294	18.212
0.160	4.473	16.200	0.141	12.707	22.200	0.155	29.484	18.212
0.165	4.512	16.500	0.146	12.966	22.800	0.160	29.546	18.462
0.168	4.628	16.800	0.151	13.030	23.400	0.165	29.734	18.711
0.173	4.628	17.000	0.155	13.175	24.100	0.169	29.799	18.711
0.178	4.742	17.300	0.160	13.352	24.700	0.175	29.799	18.462
0.183	4.820	17.600	0.164	13.416	25.300	0.180	29.987	18.960
0.188	4.859	17.900	0.168	13.626	26.000	0.186	29.987	19.459
0.192	4.975	18.200	0.172	13.723	26.600	0.192	30.303	20.457
0.197	5.013	18.400	0.176	13.835	27.200	0.195	30.177	20.707
0.201	5.129	18.700	0.182	13.964	27.800	0.200	30.429	21.206
0.206	5.129	19.000	0.186	13.996	28.400	0.206	30.365	21.705
0.210	5.244	19.300	0.190	14.222	29.000	0.210	30.553	22.453
0.215	5.360	19.700	0.194	14.238	29.600	0.216	30.553	22.952
0.220	5.399	19.900	0.199	14.415	30.200	0.220	30.618	23.451
0.225	5.515	20.200	0.203	14.479	30.800	0.226	30.680	23.950
0.230	5.515	20.400	0.208	14.624	31.400	0.231	30.744	24.699
0.235	5.630	20.700	0.212	14.673	31.900	0.236	30.744	25.197
0.240	5.668	20.900	0.217	14.770	32.500	0.241	30.932	25.696
0.243	5.668	21.100	0.221	14.898	33.100	0.245	30.870	26.195

Laboratorio di Geotecnica								
Prova Compressione Triassiale n.			Prova Compressione Triassiale n.			Prova Compressione Triassiale n.		
CIU (consolidata non drenata)			CIU (consolidata non drenata)			CIU (consolidata non drenata)		
Provino 1			Provino 2			Provino 3		
Velocità di prova (mm/min)	0.01		Velocità di prova (mm/min)	0.01		Velocità di prova (mm/min)	0.01	
tensione di confinamento (kPa)	300		tensione di confinamento (kPa)	500		tensione di confinamento (kPa)	600	
LVDT	cella di carico	Au	LVDT	cella di carico	Au	LVDT	cella di carico	Au
δ (mm)	kg	(kPa)	δ (mm)	kg	(kPa)	δ (mm)	kg	(kPa)
0.250	5.823	21.300	0.225	14.979	33.600	0.251	31.122	26.944
0.253	5.784	21.600	0.231	15.108	34.200	0.255	30.996	27.443
0.258	5.900	21.800	0.235	15.188	34.700	0.261	31.248	27.692
0.263	5.900	22.000	0.239	15.301	35.300	0.266	31.122	28.441
0.268	6.054	22.300	0.243	15.381	35.800	0.271	31.248	28.940
0.272	6.054	22.500	0.248	15.414	36.400	0.276	31.248	29.439
0.277	6.131	22.700	0.252	15.574	36.900	0.281	31.437	29.938
0.282	6.209	22.900	0.256	15.607	37.400	0.285	31.499	30.686
0.287	6.247	23.100	0.262	15.784	38.000	0.291	31.689	31.185
0.292	6.325	23.300	0.266	15.800	38.500	0.296	31.689	31.684
0.295	6.325	23.400	0.270	15.848	39.000	0.301	31.751	32.432
0.300	6.439	23.800	0.275	15.929	39.500	0.305	31.751	32.682
0.307	6.555	24.100	0.279	16.026	40.000	0.312	31.941	33.181
0.310	6.555	24.300	0.283	16.171	40.500	0.315	31.877	33.929
0.315	6.671	24.500	0.288	16.139	41.000	0.321	32.067	34.179
0.320	6.633	24.700	0.293	16.299	41.500	0.326	31.941	34.678
0.325	6.786	24.900	0.297	16.364	42.000	0.331	32.191	35.177
0.329	6.710	25.000	0.301	16.461	42.500	0.336	32.067	35.676
0.333	6.902	25.300	0.307	16.493	43.000	0.341	32.256	36.424
0.338	6.864	25.400	0.311	16.557	43.400	0.346	32.191	36.674
0.432	7.905	28.700	0.315	16.686	43.900	0.351	32.318	37.173
0.528	8.793	31.100	0.320	16.702	44.400	0.357	32.318	37.671
0.623	9.640	33.100	0.324	16.799	44.900	0.362	32.382	37.921
0.719	10.257	34.500	0.328	16.863	45.300	0.367	32.444	38.669
0.814	10.990	35.300	0.334	16.880	45.800	0.372	32.444	38.919
0.910	11.607	35.800	0.338	17.024	46.300	0.377	32.444	39.418
1.006	12.224	36.400	0.342	17.089	46.700	0.382	32.696	40.416
1.101	12.648	36.600	0.347	17.186	47.200	0.388	32.570	40.665
1.197	13.111	36.500	0.351	17.153	47.600	0.392	32.822	41.164
1.292	13.574	36.300	0.355	17.330	48.100	0.397	32.696	41.414
1.388	14.114	35.800	0.361	17.362	48.600	0.402	32.948	42.162
1.484	14.461	35.400	0.365	17.411	49.000	0.408	32.760	42.412
1.579	14.924	34.700	0.369	17.475	49.400	0.412	32.948	42.661
1.675	15.348	34.100	0.374	18.525	49.900	0.418	32.886	43.410
1.771	15.656	33.300	0.465	19.304	58.300	0.518	33.829	51.393
1.868	16.119	32.500	0.555	20.159	66.000	0.620	34.648	59.376
1.964	16.311	31.500	0.646	20.809	73.100	0.722	35.405	66.861
2.060	16.582	30.400	0.736	21.566	79.600	0.825	35.846	71.601
2.156	16.813	29.300	0.829	22.323	85.800	0.926	36.413	75.093
2.253	17.198	28.300	0.920	23.209	91.500	1.028	36.791	81.081
2.351	17.429	27.200	1.010	23.837	96.900	1.131	37.358	86.245
2.447	17.700	26.200	1.103	24.498	101.600	1.231	37.674	90.536
2.543	17.853	25.000	1.194	25.013	106.000	1.334	38.051	94.977
2.639	18.085	23.900	1.286	25.705	109.900	1.436	38.367	98.769
2.737	18.316	22.700	1.377	26.253	113.400	1.538	38.744	102.262
2.835	18.510	21.600	1.469	26.946	116.600	1.638	39.186	105.281
2.931	18.663	20.300	1.561	27.428	119.400	1.741	39.436	108.125
3.029	18.740	19.100	1.653	27.912	121.900	1.841	39.627	111.019
3.127	18.973	17.900	1.746	28.475	124.100	1.943	39.753	114.262
3.223	19.087	16.600	1.839	29.152	126.000	2.045	40.131	115.759
3.321	19.242	15.300	1.930	29.716	127.400	2.146	40.193	117.256
3.417	19.242	14.100	2.024	30.038	128.400	2.248	40.382	118.752
3.515	19.397	12.800	2.116	30.585	129.200	2.348	40.446	118.752
3.613	19.435	11.600	2.209	30.923	129.800	2.450	40.760	118.254
3.711	19.550	10.200	2.302	31.455	130.100	2.551	40.948	117.655
3.807	19.474	9.000	2.395	31.745	130.000	2.653	41.327	116.707
3.907	19.511	7.700	2.489	32.100	129.500	2.753	41.391	115.908
4.003	19.589	6.400	2.581	32.454	128.800	2.856	41.517	114.162
4.101	19.666	4.900	2.675	32.857	127.900	2.958	41.643	112.515
4.199	19.744	3.700	2.768	33.211	126.700	3.060	41.767	109.871
4.296	19.628	2.400	2.862	33.565	125.600	3.161	42.020	106.902
4.394	19.744	1.200	2.954	33.807	124.200	3.264	42.146	104.183
4.491	19.666	-0.200	3.048	34.129	122.600	3.366	42.336	100.990
4.590	19.782	-1.400	3.141	34.322	120.800	3.468	42.398	98.445

Laboratorio di Geotecnica								
Prova Compressione Triassiale n.			Prova Compressione Triassiale n.			Prova Compressione Triassiale n.		
CIU (consolidata non drenata)			CIU (consolidata non drenata)			CIU (consolidata non drenata)		
Provino 1			Provino 2			Provino 3		
Velocità di prova (mm/min)	0.01		Velocità di prova (mm/min)	0.01		Velocità di prova (mm/min)	0.01	
tensione di confinamento (kPa)	300		tensione di confinamento (kPa)	500		tensione di confinamento (kPa)	600	
LVDT	cella di carico	Au	LVDT	cella di carico	Au	LVDT	cella di carico	Au
δ (mm)	kg	(kPa)	δ (mm)	kg	(kPa)	δ (mm)	kg	(kPa)
4.688	19.705	-2.800	3.235	34.564	119.000	3.571	42.586	95.301
4.787	19.666	-3.800	3.328	34.773	117.000	3.672	42.524	92.432
4.887	19.628	-5.000	3.422	34.886	115.100	3.774	42.777	88.940
4.985	19.744	-6.300	3.514	35.127	113.000	3.877	42.777	86.245
5.084	19.666	-7.500	3.608	35.352	110.700	3.979	42.965	82.902
5.184	19.628	-8.700	3.701	35.546	108.400	4.081	43.029	80.532
5.282	19.589	-9.900	3.795	35.546	106.000	4.184	43.217	76.890
5.381	19.474	-11.100	3.888	35.755	103.700	4.285	43.281	74.345
5.481	19.511	-12.200	3.982	35.949	101.300	4.388	43.405	70.852
5.580	19.397	-13.400	4.078	35.997	98.900	4.491	43.469	68.308
5.678	19.281	-14.600	4.172	36.077	96.400	4.593	43.596	64.990
5.779	19.126	-15.700	4.268	36.077	94.000	4.695	43.658	62.295
5.879	19.126	-16.800	4.362	36.287	91.600	4.798	43.596	59.601
5.978	19.087	-17.900	4.457	36.319	89.300	4.899	43.722	57.206
6.081	18.973	-19.000	4.552	36.383	86.900	5.001	43.658	55.160
6.180	18.818	-20.100	4.647	36.352	84.600	5.103	43.658	52.940
6.282	18.740	-21.100	4.743	36.432	82.400	5.204	43.784	51.019
6.383	18.626	-22.100	4.839	36.512	80.200	5.306	43.910	48.175
6.482	18.548	-23.200	4.936	36.658	78.100	5.406	43.974	46.104
6.583	18.510	-24.000	5.030	36.674	76.000	5.508	43.910	43.584
6.685	18.316	-25.000	5.128	36.706	73.900	5.608	43.848	40.890
6.786	18.316	-26.000	5.224	36.770	71.800	5.710	43.974	37.696
6.885	18.240	-26.900	5.322	36.851	69.800	5.810	44.100	35.177
6.988	18.201	-27.800	5.418	36.980	68.100	5.910	44.036	32.782
7.087	18.124	-28.800	5.516	36.931	66.100	6.011	44.036	29.938
7.189	18.201	-29.600	5.614	36.931	64.200	6.111	44.115	27.867
7.290	18.163	-30.500	5.713	36.980	62.300	6.211	44.162	25.821
7.391	18.201	-31.300	5.812	37.108	60.600	6.311	44.162	23.750
7.490	18.047	-32.100	5.911	37.076	58.800	6.411	44.115	21.954
7.590	17.969	-32.900	6.010	37.076	57.100	6.510	44.162	20.108
7.691	17.969	-33.700	6.110	36.947	55.400	6.610	44.100	17.888
7.792	17.892	-34.400	6.210	37.076	53.800	6.709	44.162	15.817
7.892	17.969	-35.200	6.309	37.060	52.200	6.809	44.162	13.447
7.994	17.739	-35.800	6.410	37.173	50.600	6.908	44.162	11.476
8.094	17.777	-36.500	6.510	37.044	49.100	7.008	44.036	9.480
8.195	17.700	-37.200	6.609	37.108	47.600	7.107	44.162	8.033
8.296	17.777	-37.900	6.710	37.124	46.100	7.206	44.100	6.611
8.396	17.622	-38.500	6.811	37.124	44.700	7.306	44.288	5.339
8.497	17.622	-39.200	6.912	37.140	43.300	7.405	44.224	3.917
8.596	17.584	-39.800	7.013	37.012	41.900	7.504	44.224	2.819
8.699	17.661	-40.400	7.114	37.060	40.500	7.603	44.224	1.372
8.799	17.661	-41.000	7.214	37.076	39.400	7.701	44.350	0.000
8.898	17.622	-41.500	7.314	37.108	38.100	7.800	44.415	-1.148
8.998	17.700	-42.100	7.416	36.996	36.700	7.899	44.477	-1.796
9.100	17.661	-42.600	7.518	36.996	35.600	7.998	44.415	-2.595
9.201	17.777	-43.200	7.621	36.947	34.300	8.097	44.667	-3.568
9.301	17.777	-43.700	7.723	36.964	33.000	8.194	44.855	-4.166
9.402	17.853	-44.200	7.826	36.802	32.000	8.294	44.855	-4.990
9.503	17.777	-44.800	7.929	36.754	30.800	8.392	44.855	-5.838
9.604	17.892	-45.400	8.032	36.754	29.700	8.490	44.729	-6.761
9.705	17.892	-45.700	8.136	36.690	28.600	8.589	44.855	-7.285
9.808	17.892	-46.200	8.239	36.706	27.600	8.688	44.919	-8.208
9.909	17.892	-46.800	8.345	36.577	26.500	8.787	44.981	-8.956
10.012	18.008	-47.300	8.450	36.528	25.500	8.886	44.855	-9.655
10.113	17.931	-47.600	8.555	36.415	24.600	8.983	44.981	-10.553
10.216	17.969	-48.000	8.661	36.399	23.700	9.082	45.043	-11.102
10.317	18.124	-48.300	8.767	36.271	22.700	9.179	45.107	-11.825
10.420	18.047	-48.800	8.873	36.126	21.900	9.278	45.043	-12.723
10.521	18.124	-49.100	8.980	35.981	21.100	9.375	45.043	-13.297
10.624	18.163	-49.700	9.087	35.917	20.200	9.473	45.107	-13.821
10.725	18.355	-49.900	9.194	35.917	19.500	9.571	45.107	-14.395
10.826	18.355	-50.400	9.303	35.804	18.700	9.669	45.234	-14.794
10.930	18.432	-50.700	9.411	35.675	17.900	9.766	45.043	-15.443
11.033	18.471	-51.300	9.520	35.578	17.200	9.865	45.043	-15.817

Laboratorio di Geotecnica								
Prova Compressione Triassiale n.			Prova Compressione Triassiale n.			Prova Compressione Triassiale n.		
CIU (consolidata non drenata)			CIU (consolidata non drenata)			CIU (consolidata non drenata)		
Provino 1			Provino 2			Provino 3		
Velocità di prova (mm/min)	0.01		Velocità di prova (mm/min)	0.01		Velocità di prova (mm/min)	0.01	
tensione di confinamento (kPa)	300		tensione di confinamento (kPa)	500		tensione di confinamento (kPa)	600	
LVDT	cella di carico		LVDT	cella di carico		LVDT	cella di carico	
δ (mm)	kg	Au (kPa)	δ (mm)	kg	Au (kPa)	δ (mm)	kg	Au (kPa)
11.134	18.587	-51.600	9.630	35.578	16.500	9.962	45.043	-16.366
11.235	18.663	-52.000	9.740	35.482	15.800	10.061	45.107	-16.915
11.338	18.711	-52.300	9.851	35.385	15.200	10.158	45.043	-17.638
11.441	18.779	-52.700	9.962	35.208	14.500	10.257	44.855	-18.362
11.542	18.856	-52.800	10.072	35.176	14.100	10.356	44.729	-18.886
11.645	19.011	-53.200	10.183	35.063	13.500	10.455	44.667	-19.484
11.748	19.085	-53.700	10.294	34.967	12.900	10.552	44.667	-19.958
11.850	19.126	-54.100	10.407	34.854	12.400	10.651	44.541	-20.657
11.952	19.126	-54.300	10.518	34.724	12.000	10.751	44.541	-21.256
12.054	19.242	-54.500	10.631	34.724	11.500	10.850	44.415	-21.979
12.157	19.203	-55.000	10.743	34.612	11.100	10.950	44.477	-22.528
12.261	19.203	-55.200	10.856	34.515	10.700	11.049	44.350	-23.102
12.363	19.203	-55.500	10.970	34.290	10.300	11.149	44.350	-23.601
12.465	19.242	-55.900	11.084	34.242	10.000	11.248	44.162	-24.075
12.568	19.203	-56.300	11.198	34.129	9.700	11.348	44.224	-24.524
12.671	19.281	-56.500	11.311	34.113	9.300	11.448	44.162	-25.073
12.774	19.435	-56.900	11.425	33.951	9.100	11.549	44.100	-25.472
12.878	19.550	-57.200	11.539	33.839	8.900	11.649	44.036	-25.921
12.982	19.618	-57.500	11.655	33.742	8.700	11.749	44.036	-26.370
13.085	19.628	-57.800	11.769	33.661	8.500	11.851	44.100	-26.694
13.190	19.712	-58.000	11.882	33.565	8.400	11.951	43.910	-26.919
13.294	19.858	-58.400	11.998	33.436	8.200	12.053	43.848	-27.443
13.398	19.938	-58.500	12.114	33.388	8.100	12.154	43.596	-27.692
13.503	19.938	-58.800	12.230	33.291	8.100	12.256	43.531	-27.942
13.607	20.018	-59.000	12.346	33.339	8.000	12.356	43.405	-28.141
13.713	20.052	-59.200	12.463	33.130	8.000	12.458	43.343	-28.516
13.819	19.992	-59.400	12.580	33.114	8.000	12.558	43.091	-28.516
13.924	20.018	-59.500	12.698	32.985	8.000	12.660	43.091	-28.690
14.030	19.938	-59.800	12.816	33.001	8.000	12.761	42.903	-28.690
14.132	19.938	-59.900	12.934	32.920	8.000	12.863	42.839	-28.690
14.242	19.992	-60.000	13.052	32.792	8.100	12.963	42.586	-28.690
14.348	19.965	-60.100	13.171	32.695	8.100	13.066	42.462	-28.441
14.452	19.965	-60.100	13.290	32.695	8.100	13.166	42.336	-28.366
14.558	19.938	-59.900	13.410	32.695	8.200	13.268	42.210	-28.091
14.664	19.858	-59.900	13.530	32.566	8.300	13.368	42.084	-27.942
14.769	19.912	-60.000	13.651	32.550	8.400	13.470	41.831	-27.817
14.875	19.858	-60.200	13.773	32.422	8.500	13.572	41.705	-27.792
14.979	19.858	-60.400	13.895	32.486	8.700	13.673	41.643	-27.692
			14.017	32.438	8.800	13.775	41.517	-27.642
			14.142	32.373	8.900	13.875	41.391	-27.592
			14.264	32.260	9.000	13.977	41.201	-27.418
			14.389	32.292	9.200	14.079	41.012	-27.193
			14.515	32.292	9.400	14.180	40.886	-26.944
			14.641	32.228	9.600	14.282	40.824	-26.470
			14.766	32.132	9.800	14.383	40.634	-26.096
			14.892	32.035	9.900	14.485	40.446	-25.821
			15.020	31.890	10.200	14.587	40.320	-25.696
			15.147	31.810	10.700	14.691	40.446	-25.522
			15.270	31.890	11.000	14.793	40.255	-25.197
			15.397	31.616	11.200	14.895	40.067	-24.948
			15.524	31.519	11.400	14.996	39.815	-24.699
			15.650	31.504	11.500	15.098	39.753	-24.299

Prova Triassiale CIU SNME01-C12

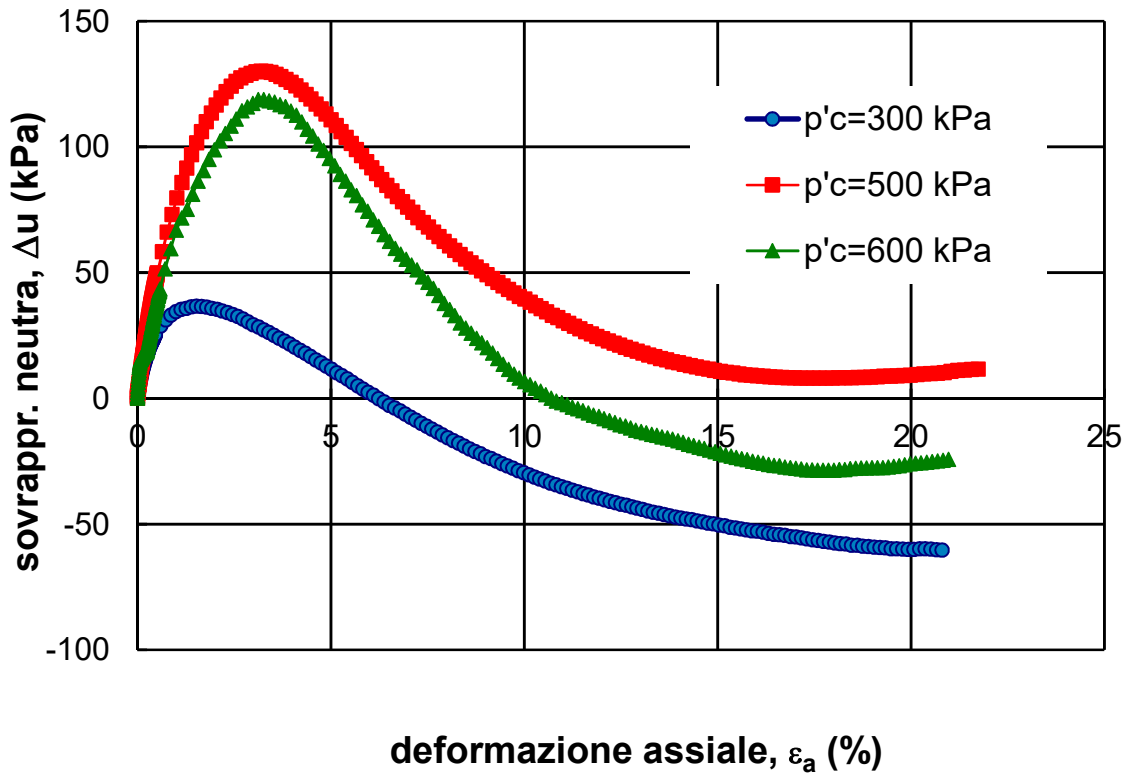
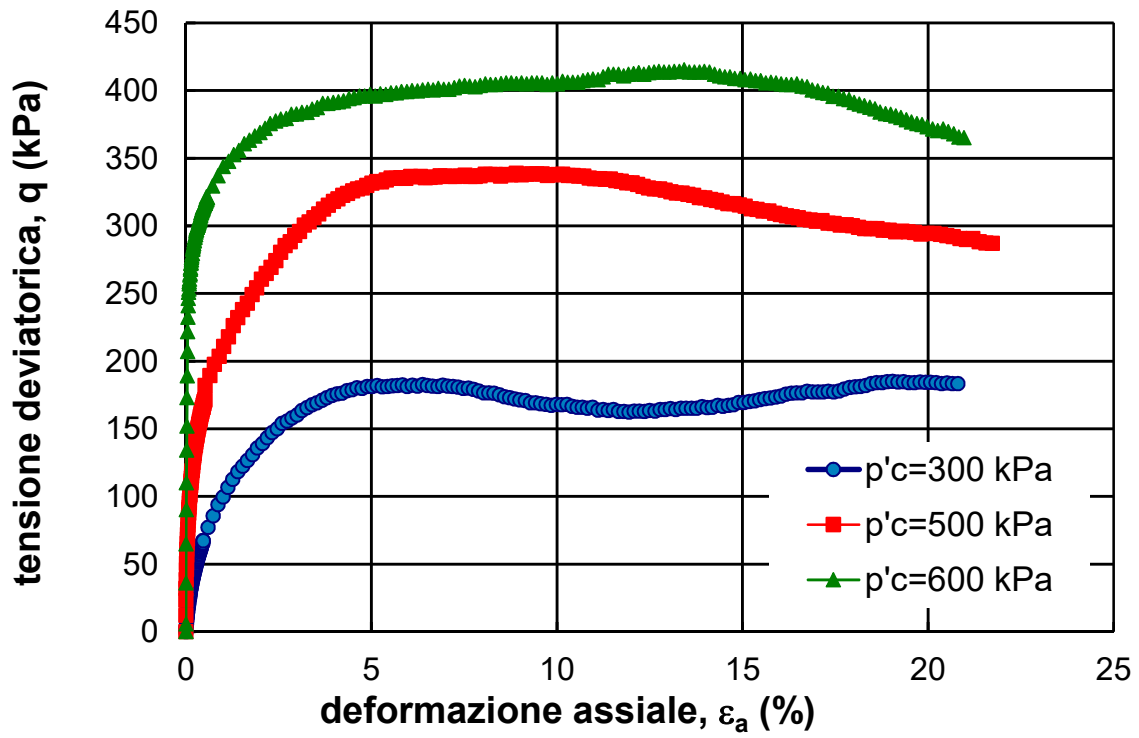

Prova Triassiale CIU SNME01-C12

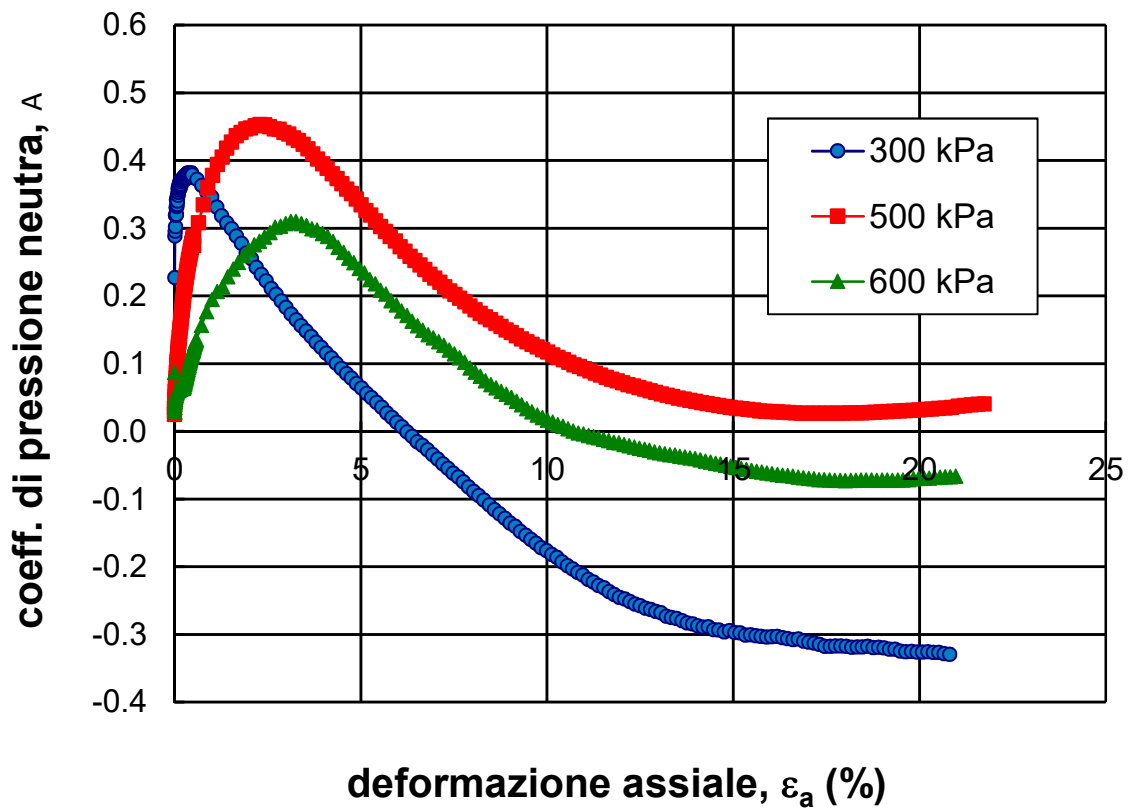
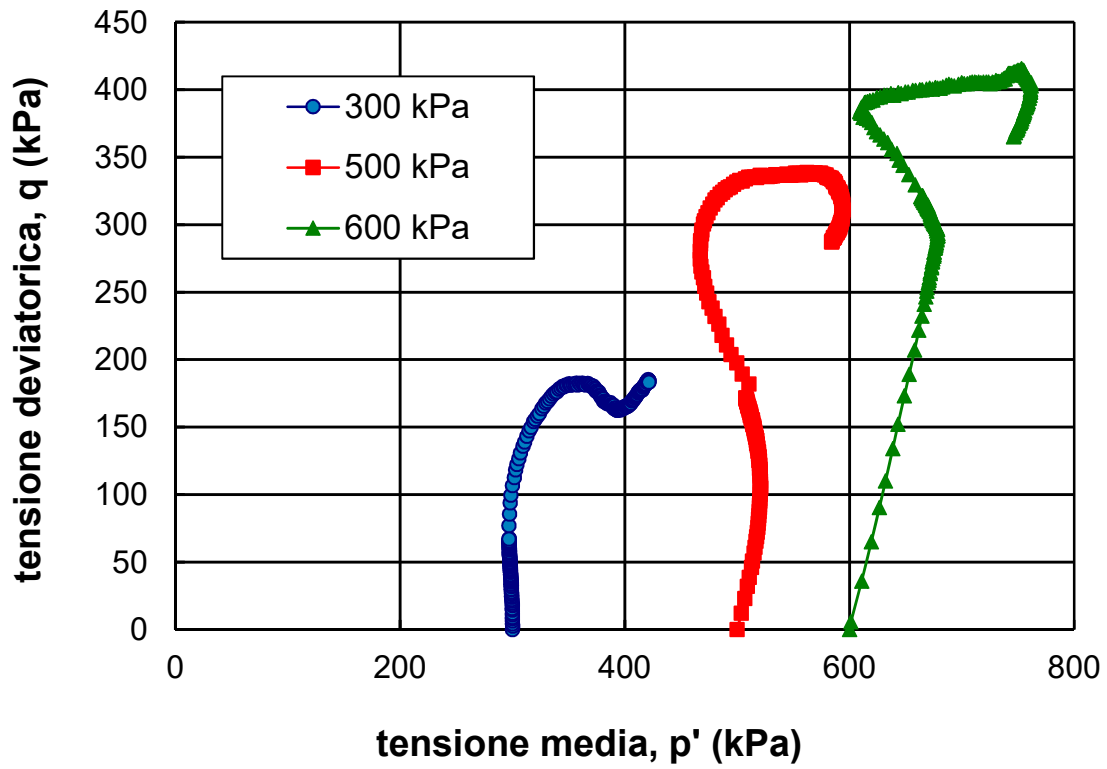

Prova Triassiale CIU SNME01-C12

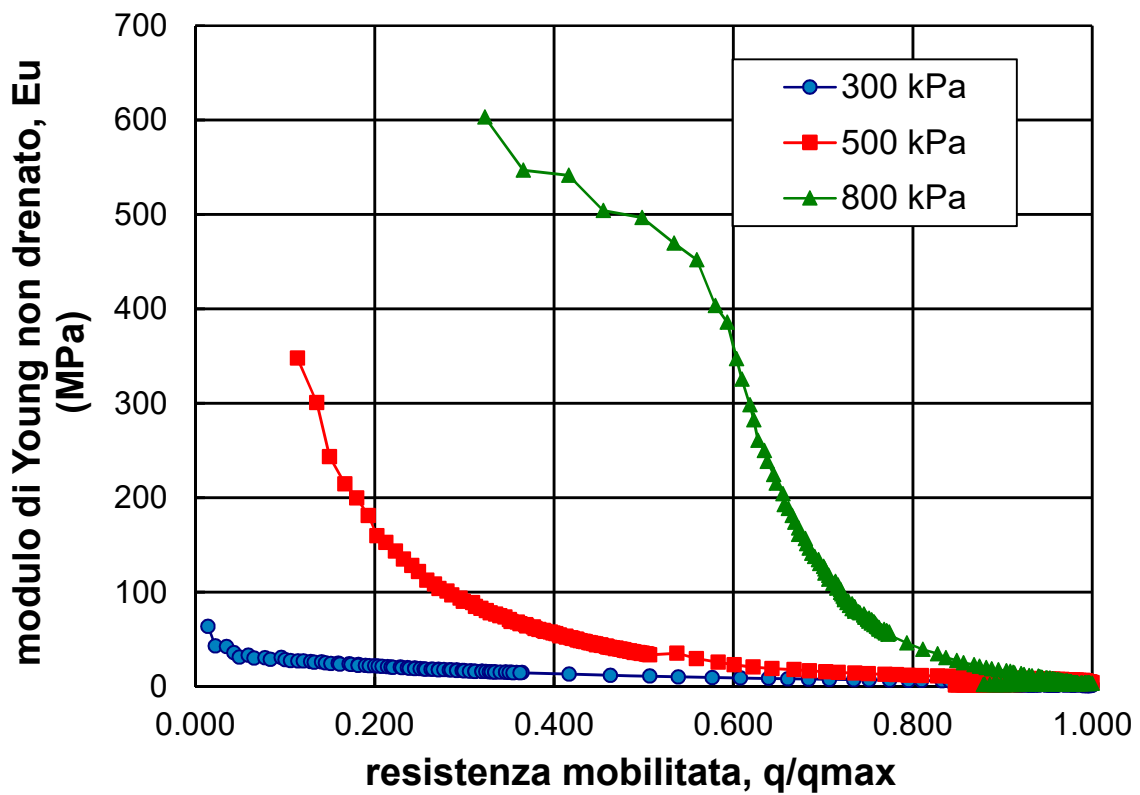
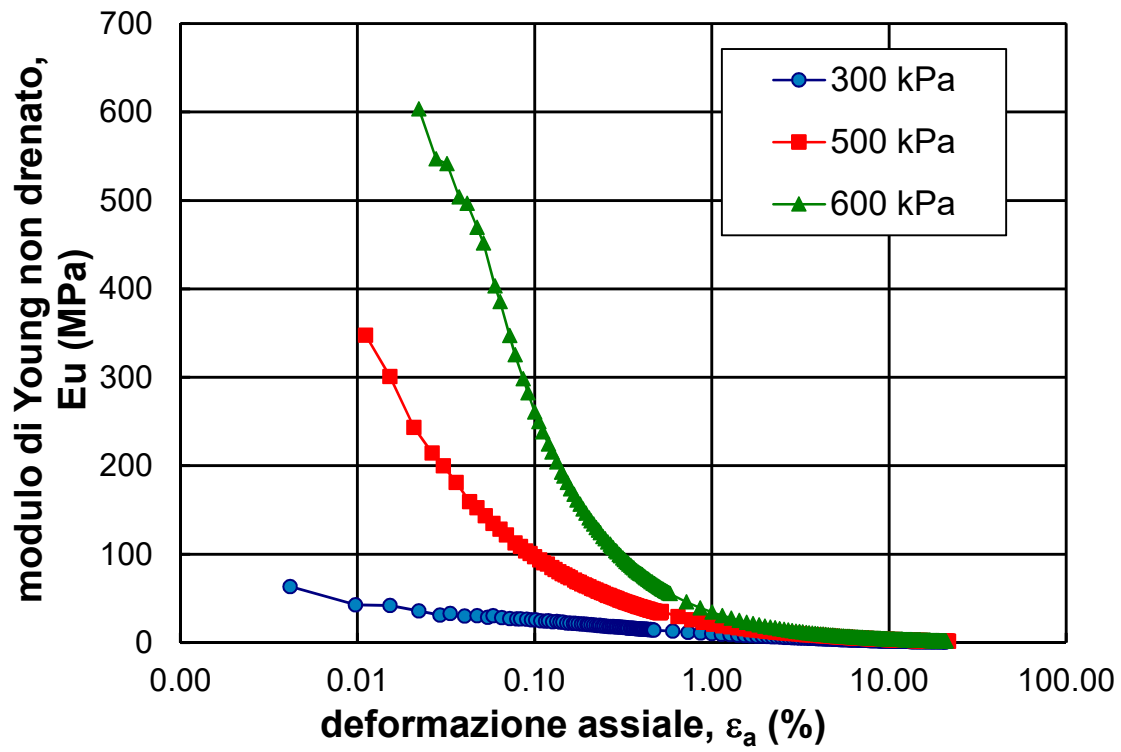

Prova Triassiale CIU SNME01-C12

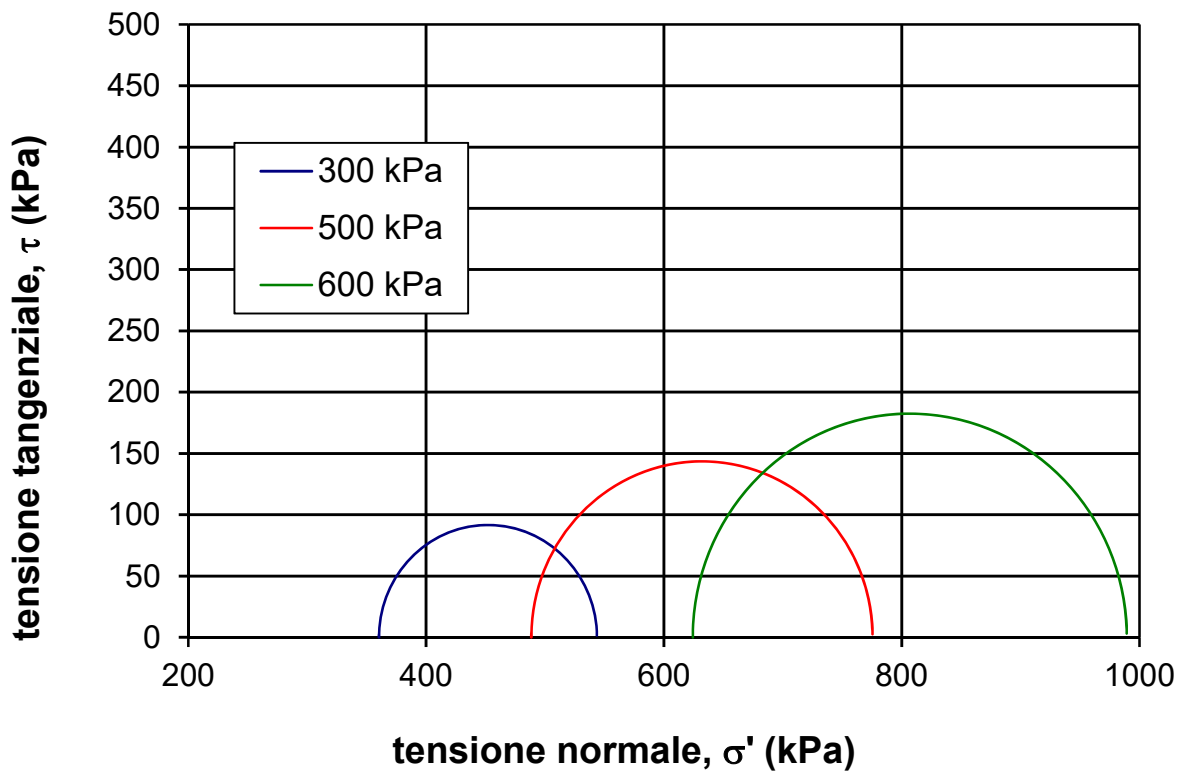
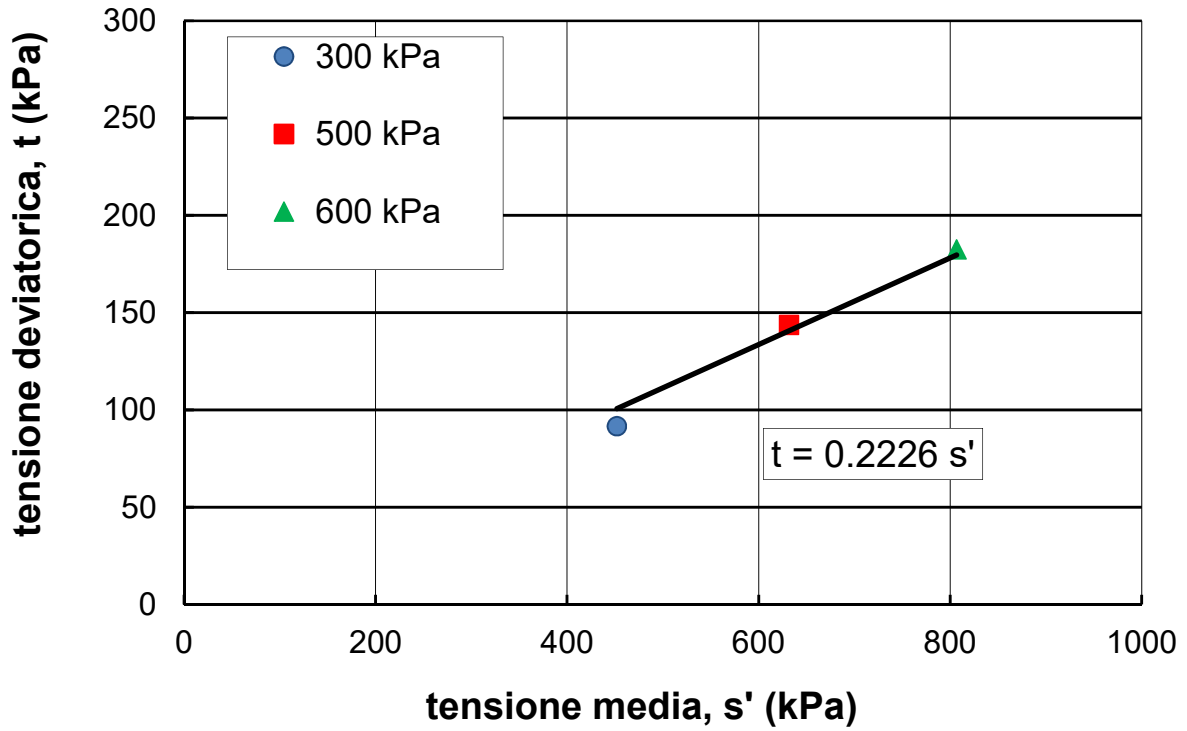

Prova Triassiale CIU SNME01-C12

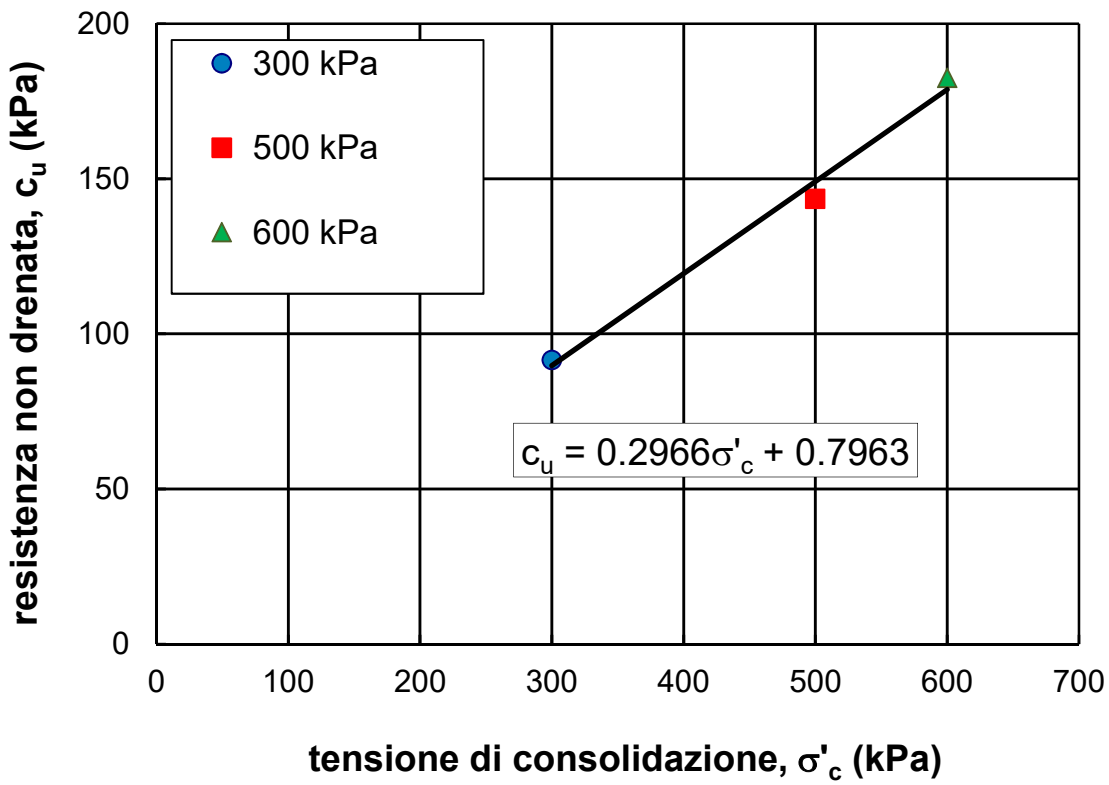
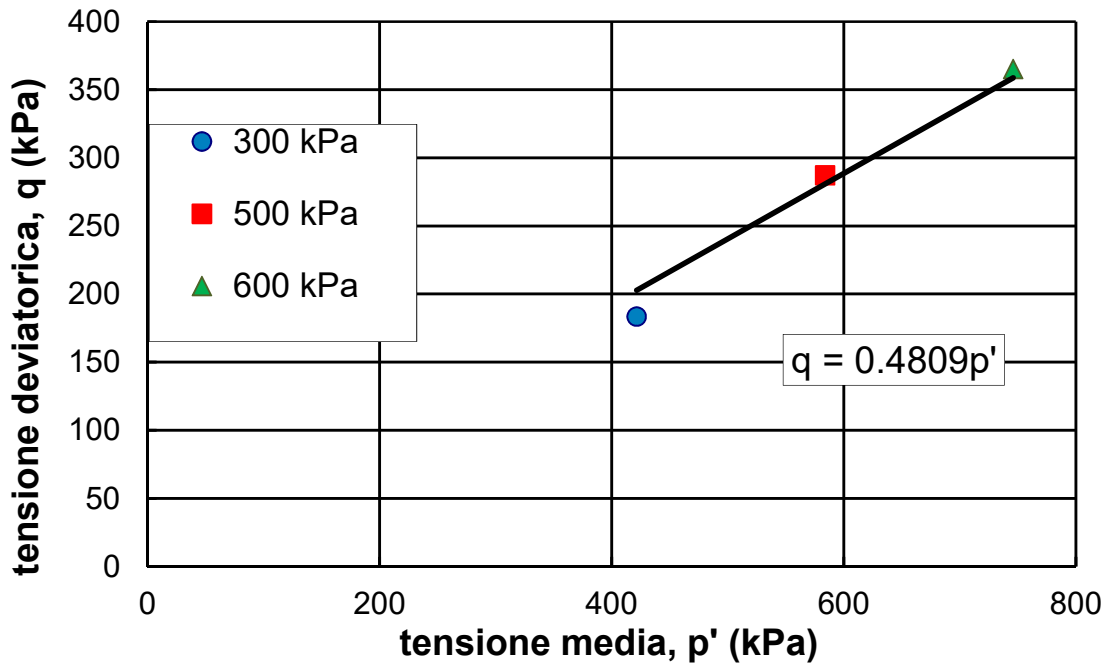



Università degli Studi di Napoli
Dipartimento di Ingegneria Civile, Edile e Ambientale
Laboratorio di Geotecnica

Committente	Consorzio HirpiniaAV
Indagine	Apice-Hirpinia
Sondaggio	SNME01
Campione	C12
Profondità	78.50-79.00
Data	09/12/2019
Operatore	Alfredo Ponzio

Peso specifico del solido	
Peso specifico dell'acqua (γ_w) (g/cm ³)	1.000
picnometro n°	18.000
Peso picnometro (P_p) (g)	41.9
Peso picnometro + acqua (P_{pw}) (g)	139.930
Volume picnometro (V_p) (cm ³)	98.03
Peso picnometro + terreno (P_{ps}) (g)	62.06
Peso terreno (P_s)	20.16
Peso picnometro + terreno + acqua (P_{psw}) (g)	152.820
Volume acqua aggiunta (V_w) (cm ³)	90.76
Volume terreno (V_s) (cm ³)	7.270
Peso specifico del terreno (γ_s) (kN/m ³)	27.192

Caratteristiche Fisiche Generali				
pesafiltro n°	20	33	154	23
Peso contenitore (P_c) (g)	15.54	15.1	11.83	11.95
Diametro (D) (mm)				
Altezza (H) (mm)				
Volume (V) (cm ³)	0.00			
Peso lordo umido (P_u) (g)	78.00	57.8	47.01	49.47
Peso lordo secco (P_s) (g)	70.50	52.07	40.92	43.61
Contenuto d'acqua (w)	0.14	0.15	0.21	
Peso umido unità di volume (γ) (kN/m ³)				
Peso secco unità di volume (γ_d) (kN/m ³)				
Peso specifico del solido (γ_s) (kN/m ³)	27.19			
Porosità (n)				
Indice dei vuoti (e)				
Grado di Saturazione (S_r)				

il responsabile della sperimentazione

Anna d'Onofrio
prof. Ing. Anna d'Onofrio