

CARPENTERIA PILA P07
BINARIO PARI
Scala 1:50



TABELLA PILE (m)

Pila	P.F.	Q.T.	Q.S.	Q.F.	H Pila
P07	+258.62	+254.82	+247.22	+244.72	7.60

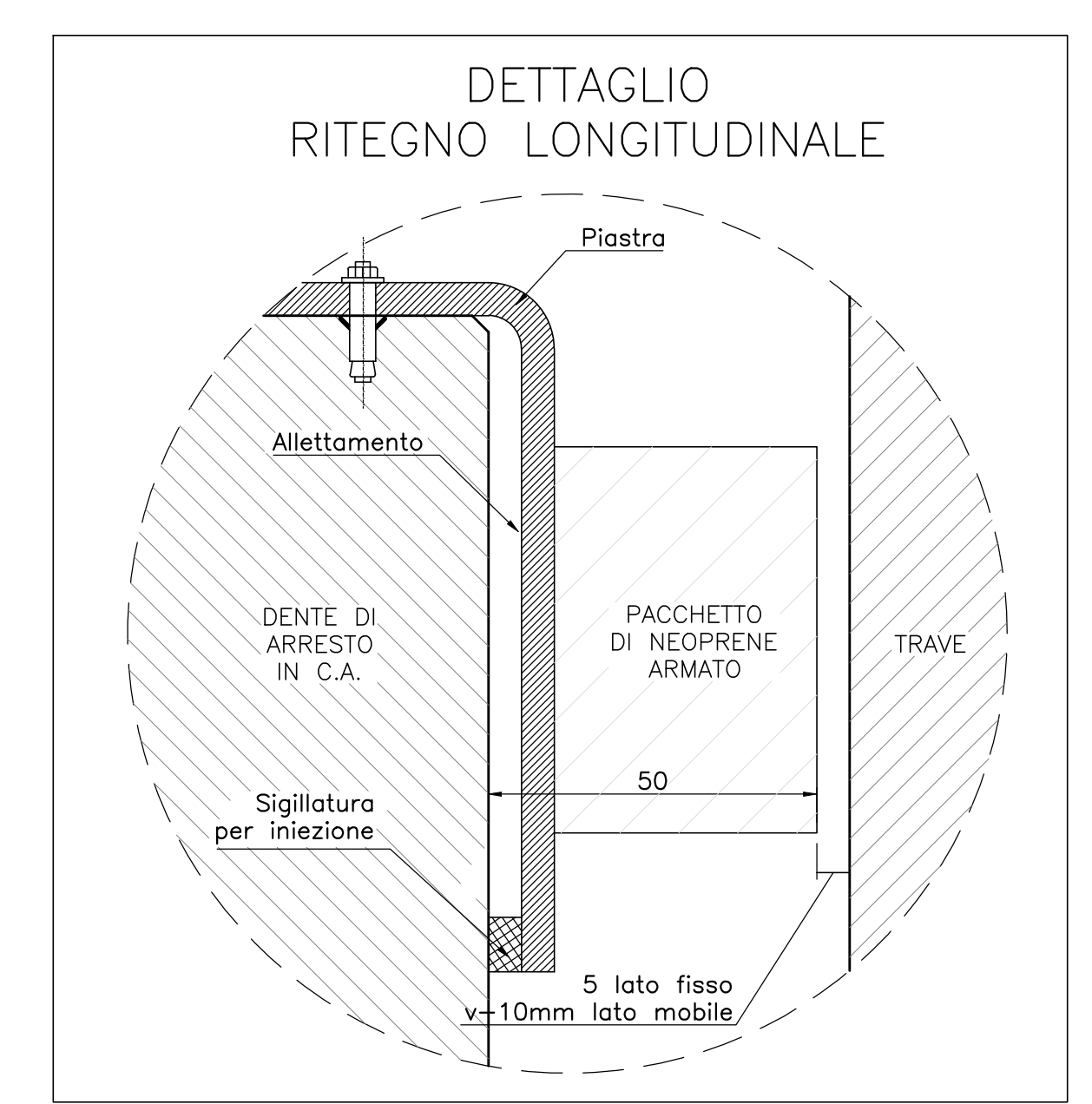
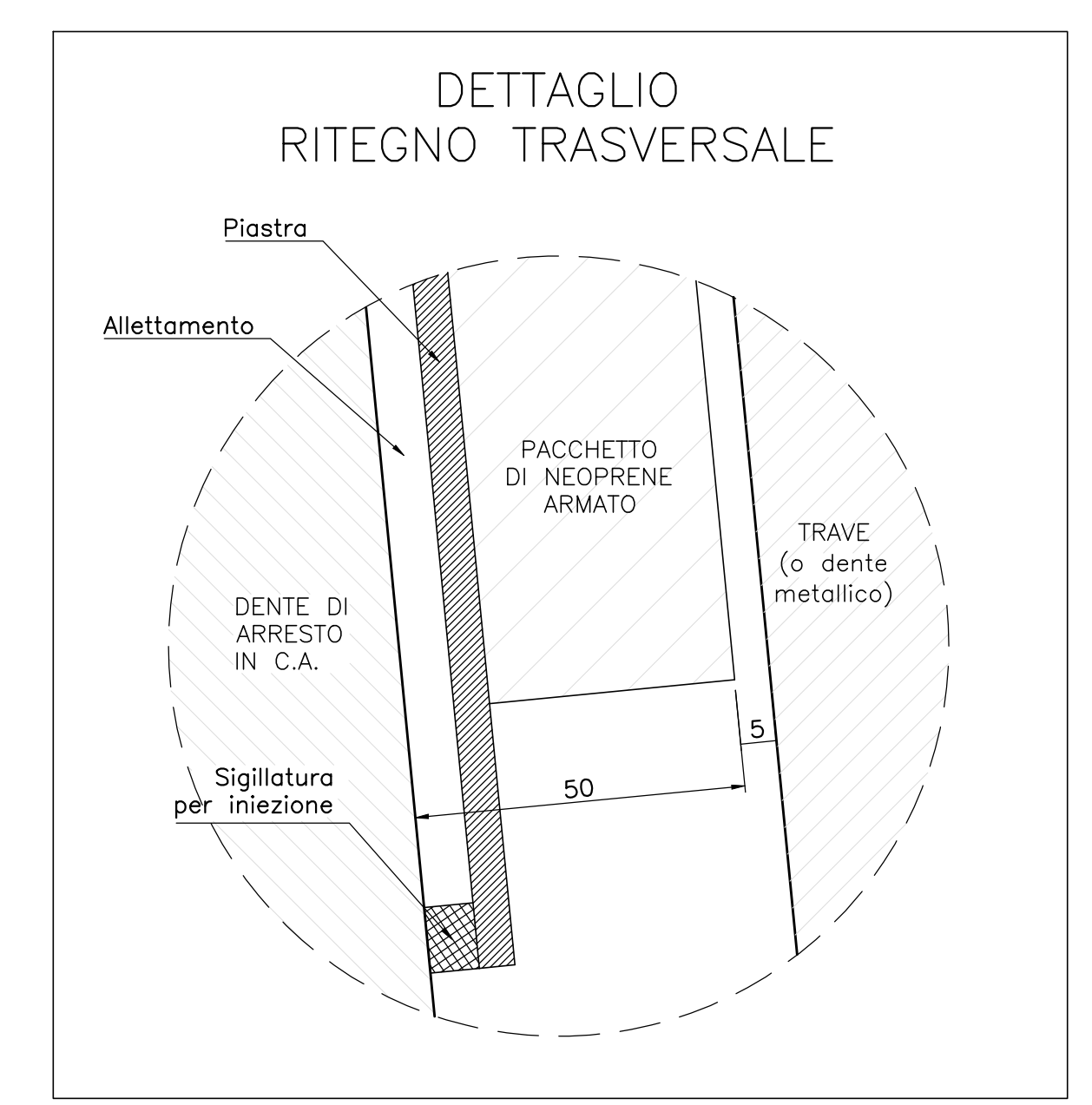
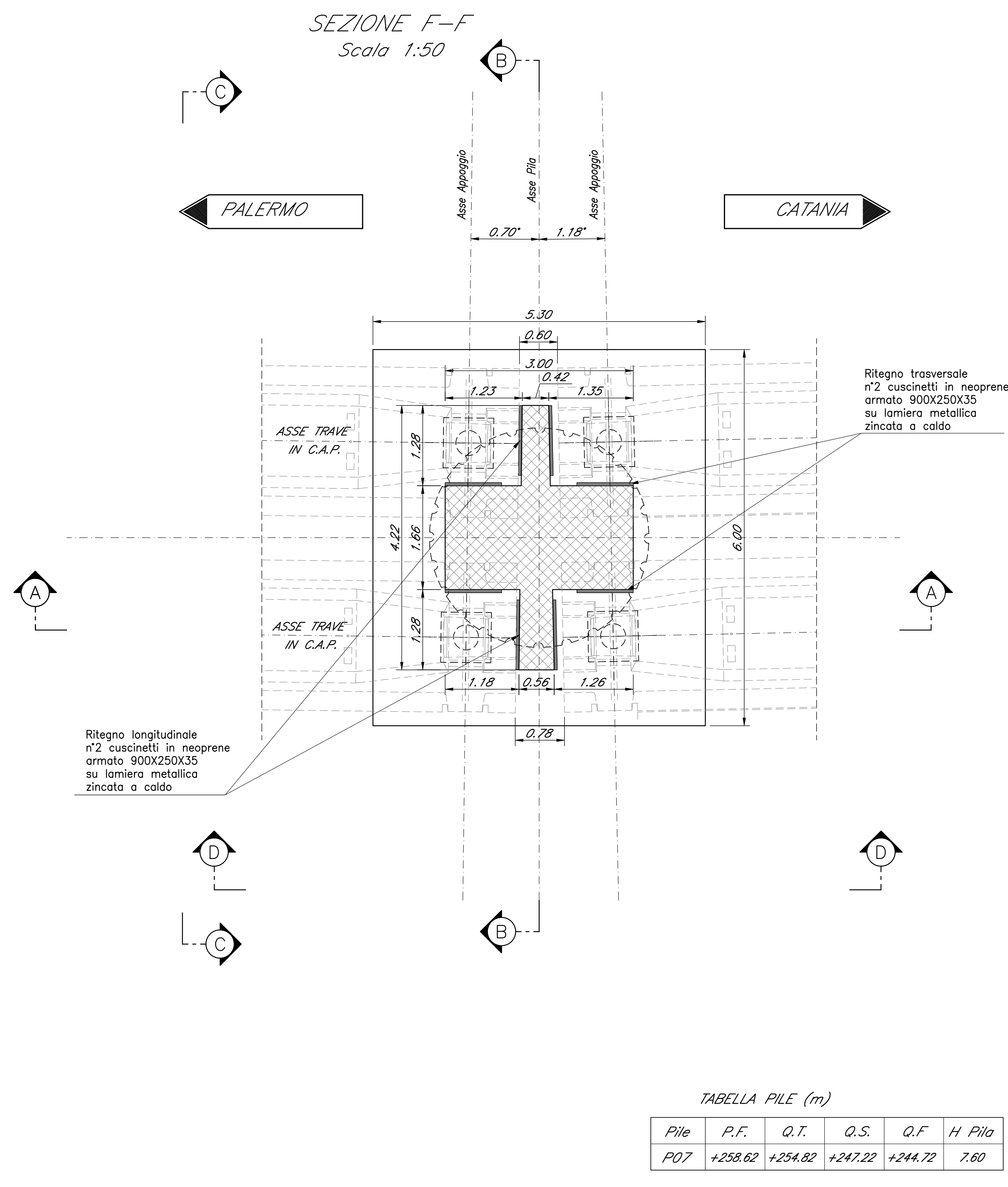
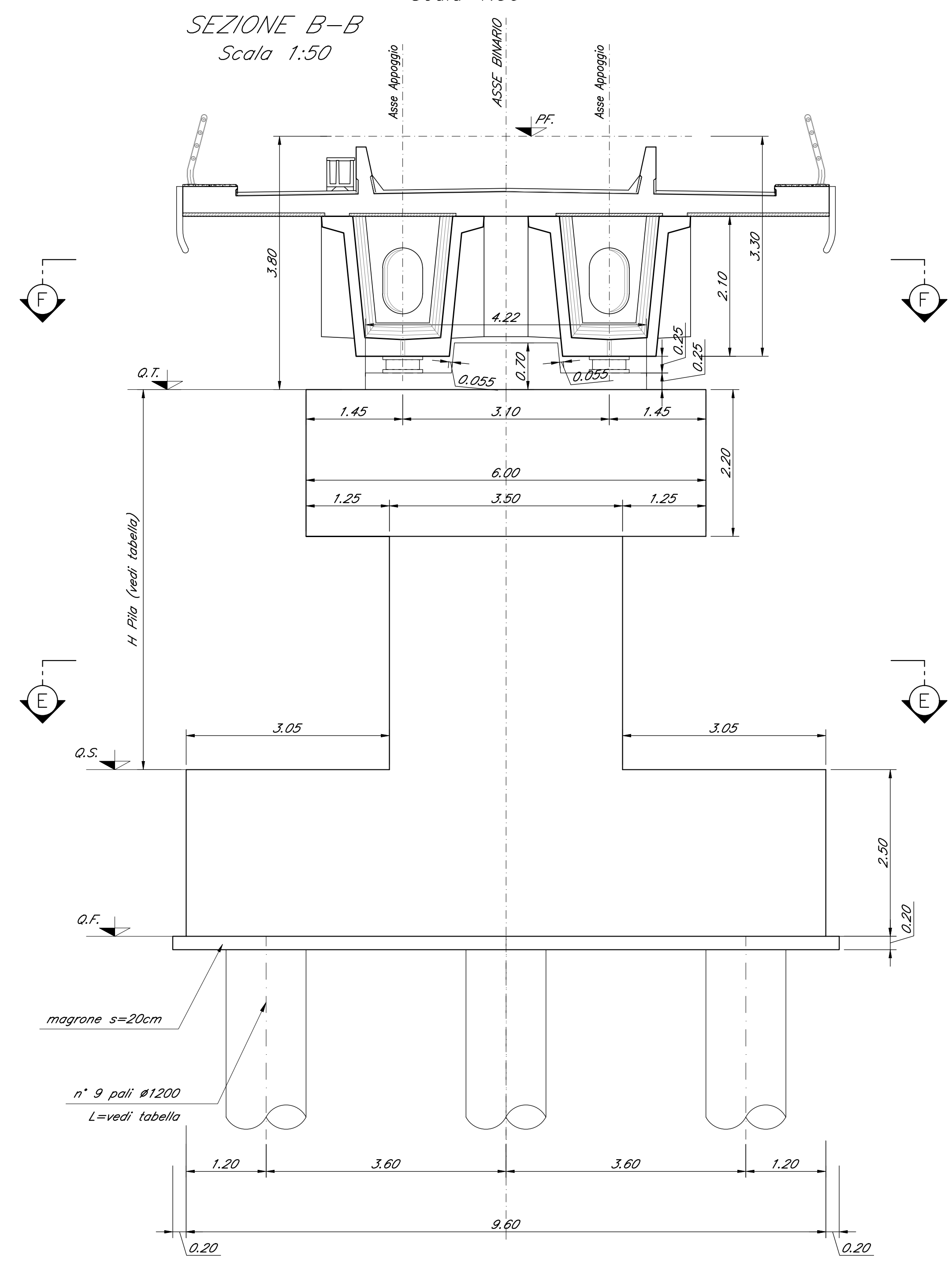
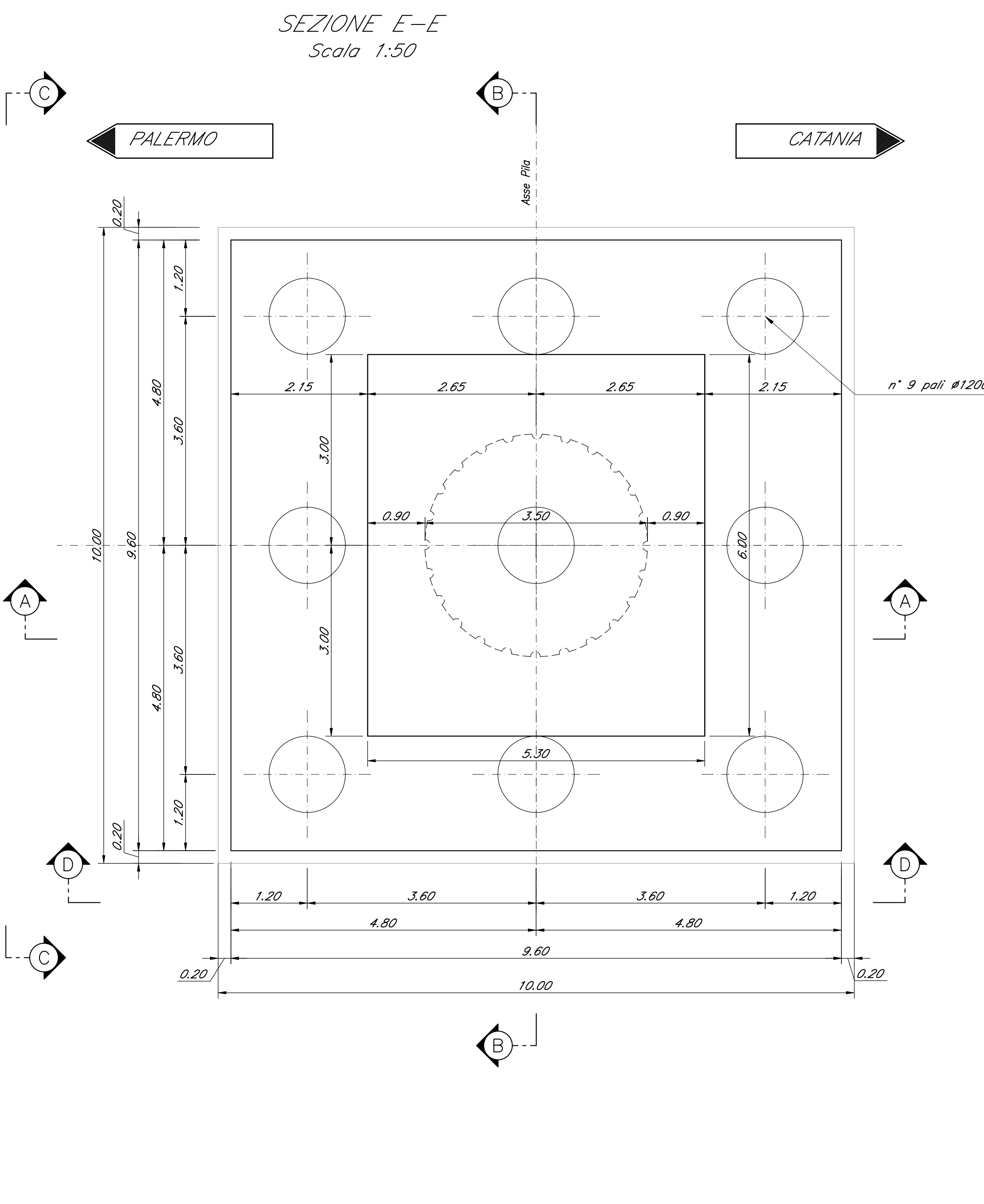
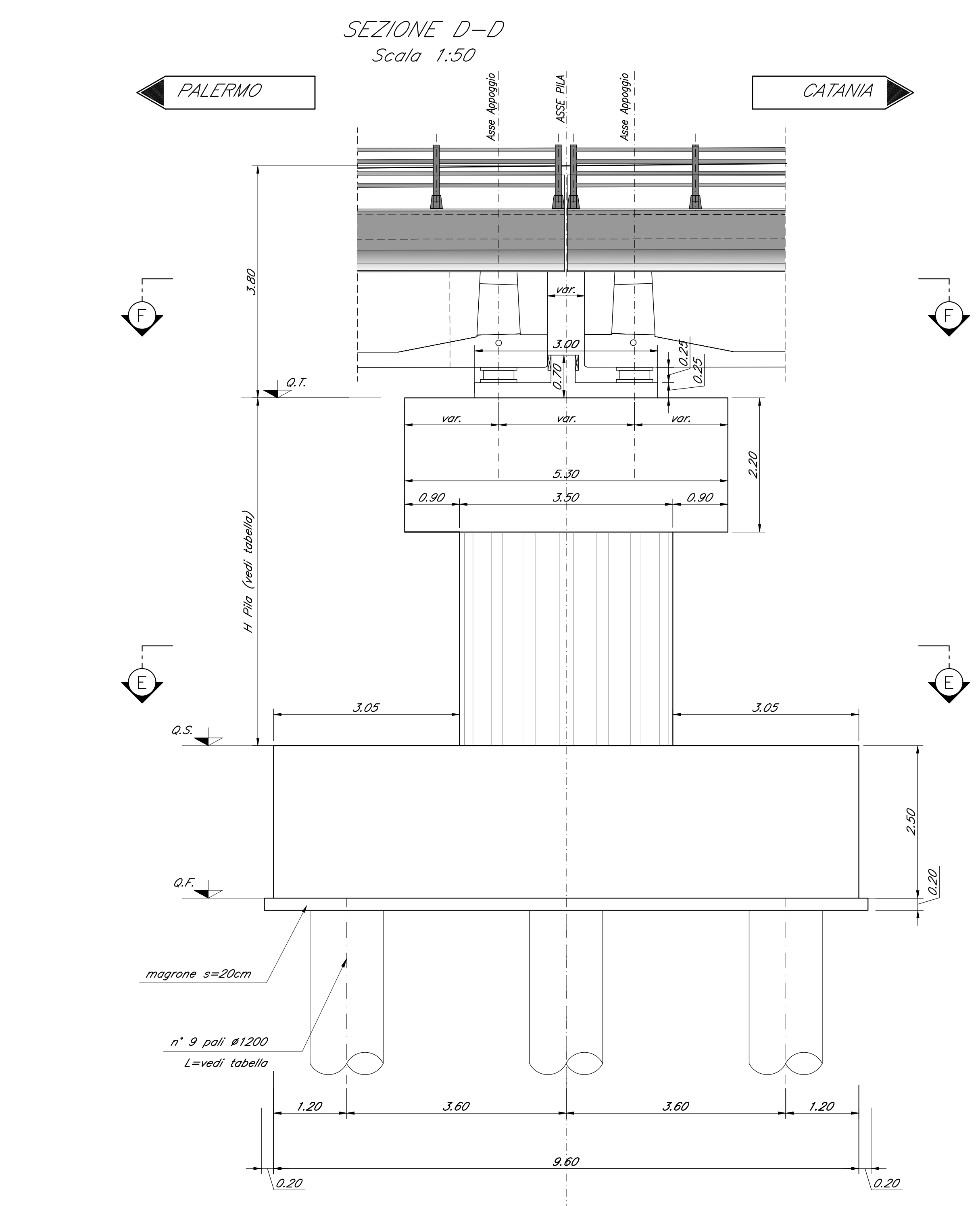
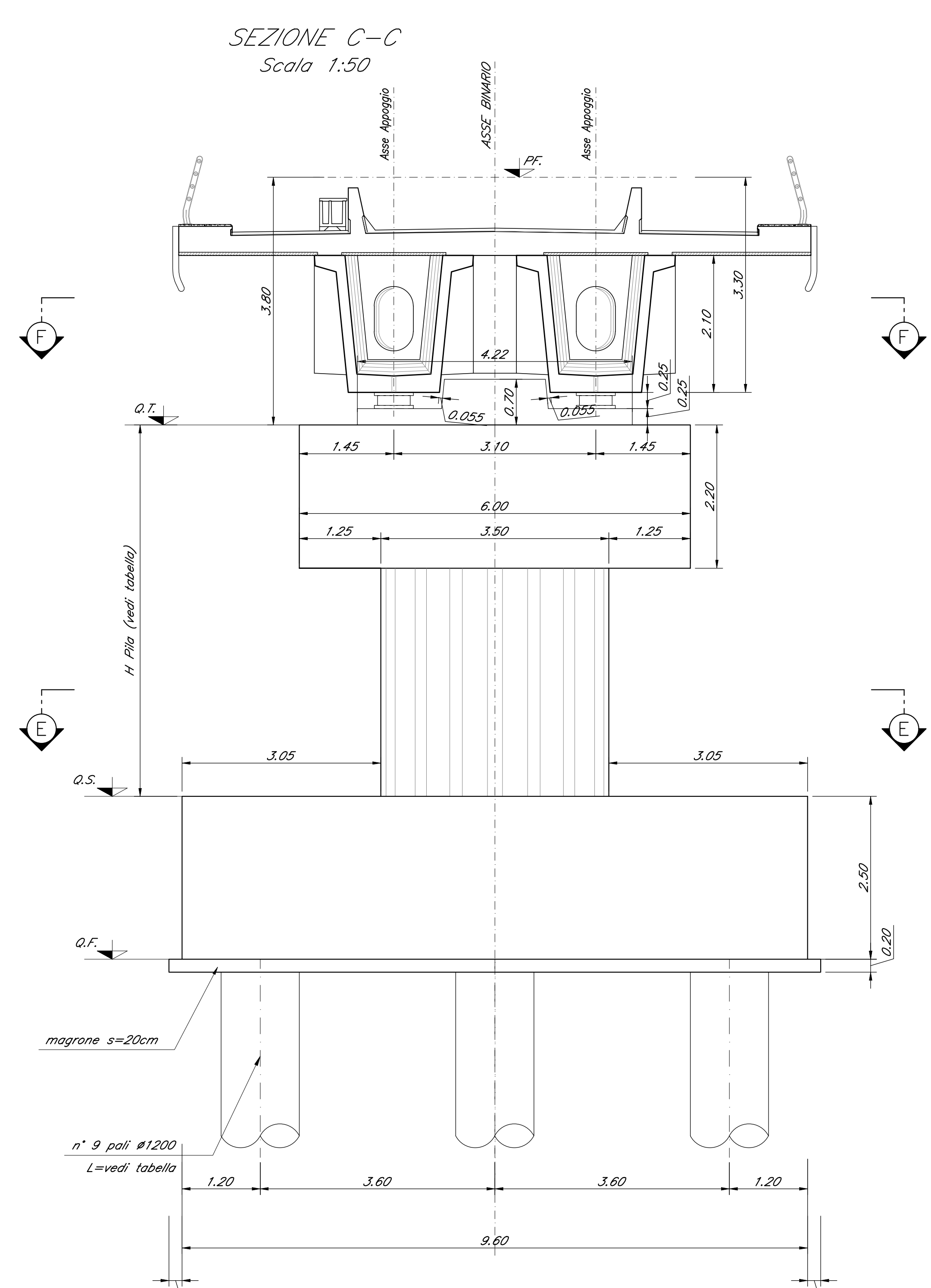
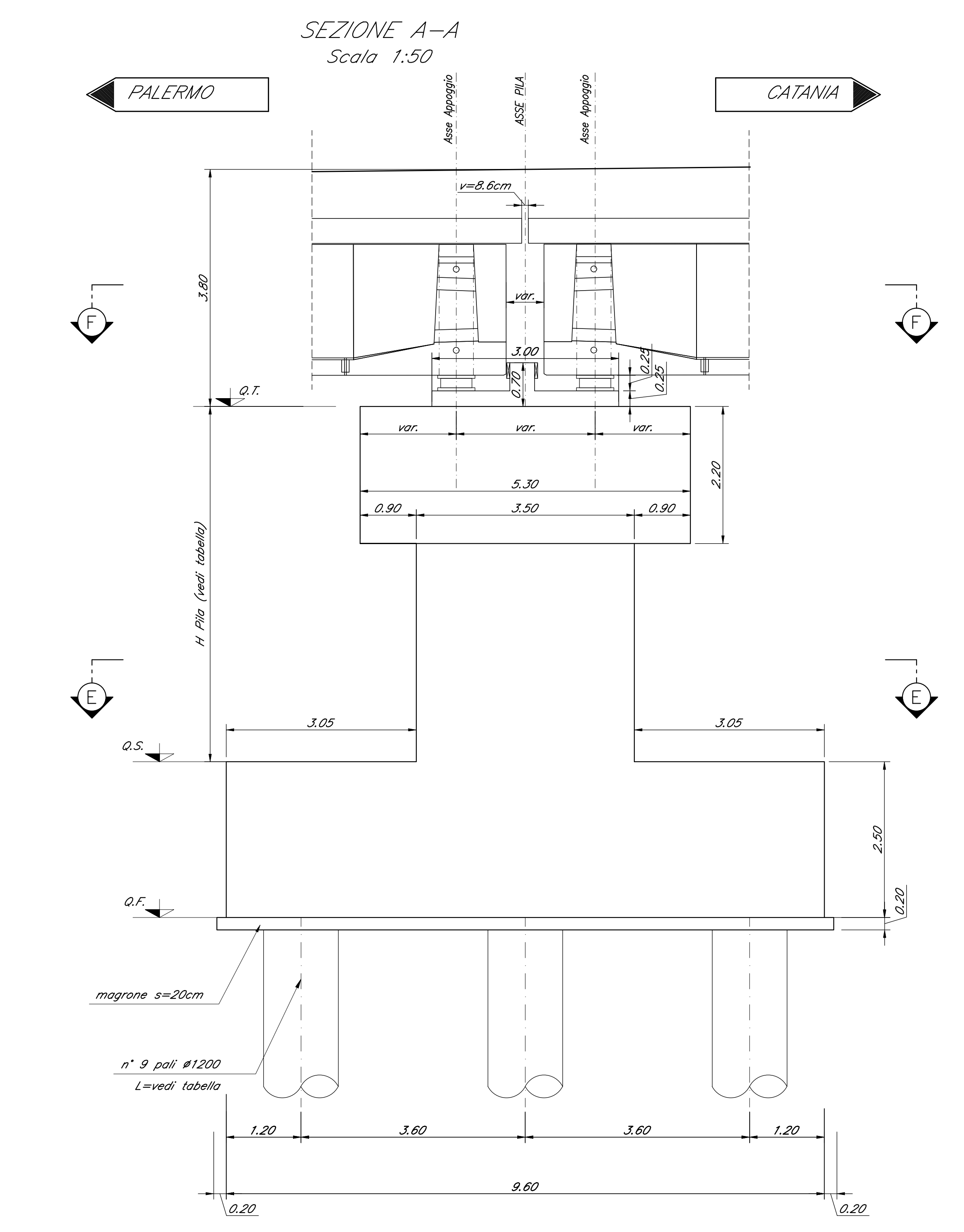

Nota:
Le quote dei baggioni sono indicate e andranno verificate con l'altezza effettiva degli apparecchi di appoggio.

COMMITTENTE: RFI RETE FERROVIARIA ITALIANA GRUPPO FERROVIE DELLO STATO ITALIANE

PROGETTAZIONE: ITALFERR

DIRETTRICE FERROVIARIA MESSINA - CATANIA - PALERMO
NUOVO COLLEGAMENTO PALERMO - CATANIA

U.O. OPERE CIVILI E GESTIONE DELLE VARIANTI

PROGETTO DEFINITIVO

TRATTA DITTAINO - CATENANUOVA (LOTTO 5)

OPERE PRINCIPALI - PONTI E VIADOTTI

VI03 - Viadotto ferroviario, L=780 m
Carpenteria Pila 7

SCALA: 1:50

Rev.	Descrizione	Redatto	Data	Verificato	Data	Approvato	Data	Autore	Stato
A	Emissione esecutiva	G. Siani	10/01/2015		10/01/2015		10/01/2015		

File: R33E5009P2V305007A.dwg n. Elib:1217