

QUADRO D'UNIONE

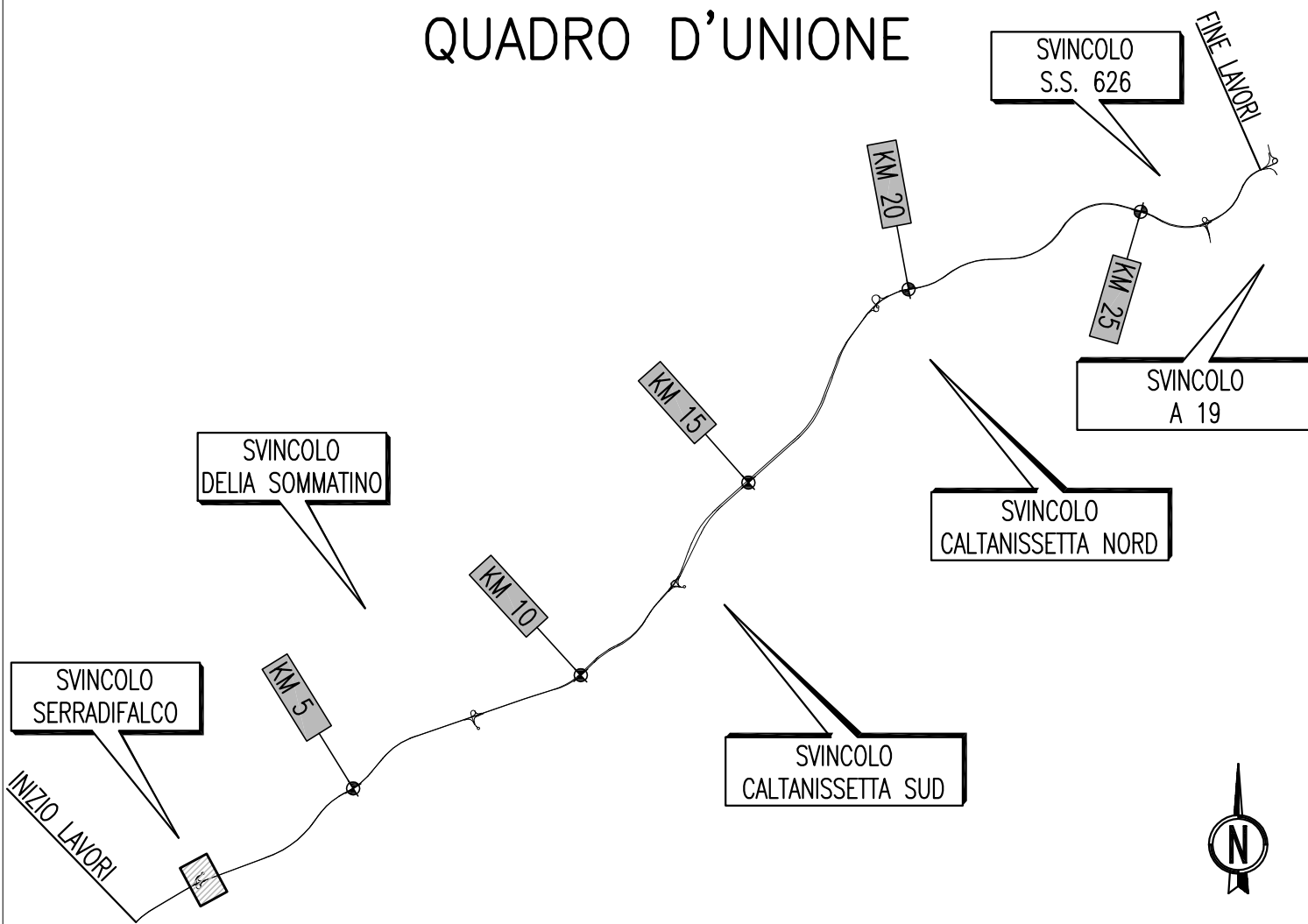

ANAS S.p.A.

DIREZIONE CENTRALE PROGRAMMAZIONE PROGETTAZIONE

PA 12/09
 CORRIDOIO PLURIMODALE TIRRENICO - NORD EUROPA
 ITINERARIO AGRIGENTO - CALTANISSETTA - A19
 S.S. N° 640 "DI PORTO EMPEDOCLE"
 AMMODERNAMENTO E ADEGUAMENTO ALLA CAT. B DEL D.M. 5.11.2001
 Dal km 44+000 allo svincolo con l'A19

PROGETTO ESECUTIVO

Contraente Generale:



INTERSEZIONI E SVINCOLI - VIABILITA' INTERFERITA VIABILITA' - Sezioni trasversali

Sezioni Trasversali - Viabilità Complementare - Tronco 3

Codice Unico Progetto (CUP) : F91B09000070001											
Codice Elaborato:											
PA12_09 - E										Scala: 1:200	
0 0 0 G E 2 1 2 P V 0 6 Z W 9 0 0 4 A											
F											
E											
D											
C											
B											
A	Aprile 2011	EMISSIONE				S.TERRENO	A.TURSO	M. LITI	P. PAGLINI		
REV.	DATA	DESCRIZIONE				REDATTO	VERIFICATO	APPROVATO	AUTORIZZATO		
Responsabile del procedimento: Ing. MAURIZIO ARAMINI											

Il Progettista: 	Il Consulente Specialista: 	Il Geologo: 	Il Coordinatore per la sicurezza in fase di progetto: 	Il Direttore dei lavori:
---------------------	--------------------------------	-----------------	---	------------------------------

SCAVI E BONIFICHE	
STERRO	1.35 mq
SCOTICO	7.36 m
BONIFICA	8.95 mq
FOSSO (SEZ. OBBL.)	0.60 mq
SCAVO A GRADONI	3.99 m
GRADONI SCAVO	2.05 mq

RILEVATI	
RILEVATO	3.55 mq
TERRENO VEGETALE	2.25 mq

SOVRASTRUTTURA STRADALE	
STRATO DI USURA	0.20 mq
STRATO DI BINDER	0.28 mq
STRATO DI BASE	0.42 mq
STRATO DI FONDAZIONE	2.76 mq

MANUFATTI	
MAGRONE	0.14 mq

SEZIONE N. : 24
 QT. PROGETTO : 504.333
 DIST.PROG. : 0+204.213
 DIST.PREC. : 4.213
 DIST.SUCC. : 0.032

SCALA 1:200

QT.RIF. 490.000

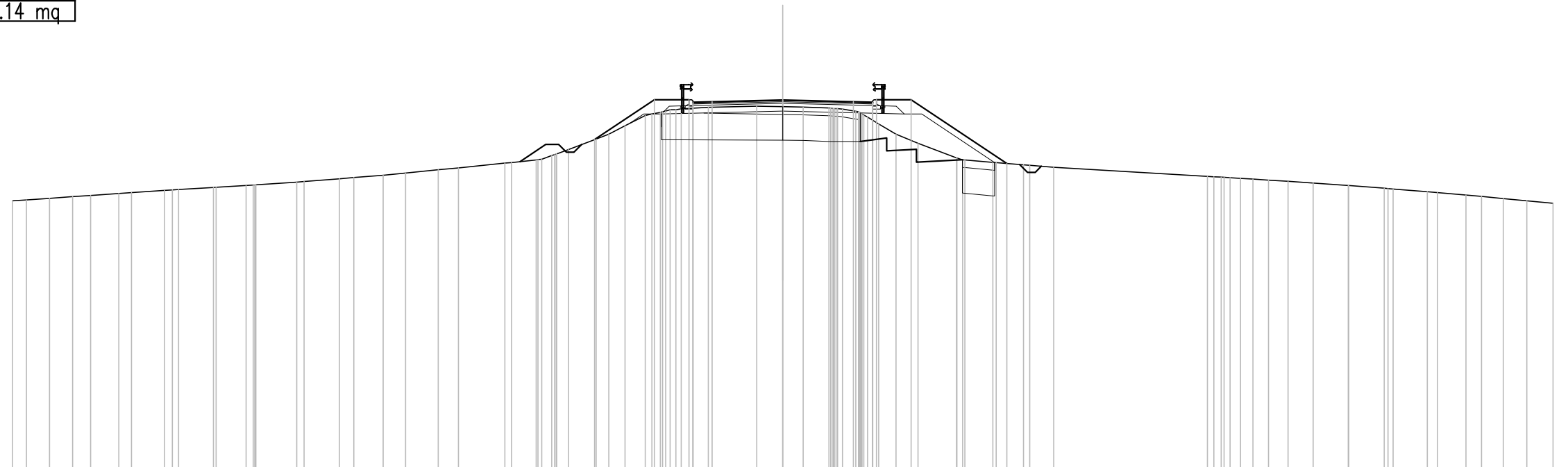

Q. PROG. STRATO SUP.	504.22 504.25 504.26 504.33 504.26 504.22																																																																					
Q. PROG. STR. SUP. TER. VEG.	502.79 504.35 504.35 504.35 501.86																																																																					
QUOTE TERRENO	500.41	500.44	500.51	500.57	500.62	500.69	500.73	500.81	500.85	500.93	500.93	501.00	501.03	501.14	501.16	501.26	501.31	501.40	501.49	501.61	501.69	501.87	501.90	502.00	502.18	502.41	502.81	503.00	503.33	503.73	503.85	503.95	503.99	504.04	504.09	504.07	504.06	504.02	503.98	503.89	503.86	503.66	503.40	503.00	502.65	502.08	502.00	501.90	501.89	501.80	501.79	501.71	501.36	501.33	501.28	501.25	501.21	501.17	501.10	501.00	501.00	500.90	500.87	500.76	500.72	500.64	500.58	500.49	500.41	500.31
DISTANZE PARZIALI STRATO SUP.	0.75 2.75 2.75 0.75																																																																					
DISTANZE PROG STRATO SUP.	-7.33 -5.00 -3.65 -3.65 -5.00 -8.73																																																																					
DISTANZE TERRENO	-30.00	-29.46	-28.56	-27.66	-26.96	-25.96	-25.36	-24.07	-23.53	-22.17	-22.07	-20.90	-20.52	-18.93	-18.65	-17.27	-16.71	-15.57	-14.69	-13.42	-12.63	-10.82	-10.56	-9.60	-9.00	-8.34	-7.27	-6.78	-6.14	-5.35	-4.77	-4.16	-3.96	-2.90	-1.02	0.00	0.80	1.80	2.32	2.84	3.30	3.74	4.41	5.27	6.77	7.09	8.19	8.32	9.37	9.62	10.56	16.54	17.07	17.82	18.31	18.92	19.68	20.66	22.02	22.04	23.42	23.77	25.10	25.50	26.61	27.22	28.06	28.98	30.00	

SCAVI E BONIFICHE	
SCOTICO	9.21 m
BONIFICA	9.20 mq
FOSSO (SEZ. OBBL.)	0.36 mq
SCAVO A GRADONI	9.62 m
GRADONI SCAVO	6.97 mq

RILEVATI	
RILEVATO	9.87 mq
TERRENO VEGETALE	3.30 mq

SOVRASTRUTTURA STRADALE	
STRATO DI USURA	0.20 mq
STRATO DI BINDER	0.28 mq
STRATO DI BASE	0.42 mq
STRATO DI FONDAZIONE	2.76 mq

MANUFATTI	
MAGRONE	0.14 mq

SEZIONE N. : 30
 QT. PROGETTO : 508.629
 DIST.PROG. : 0+250.000
 DIST.PREC. : 10.000
 DIST.SUCC. : 10.000

SCALA 1:200

QT.RIF. 495.000

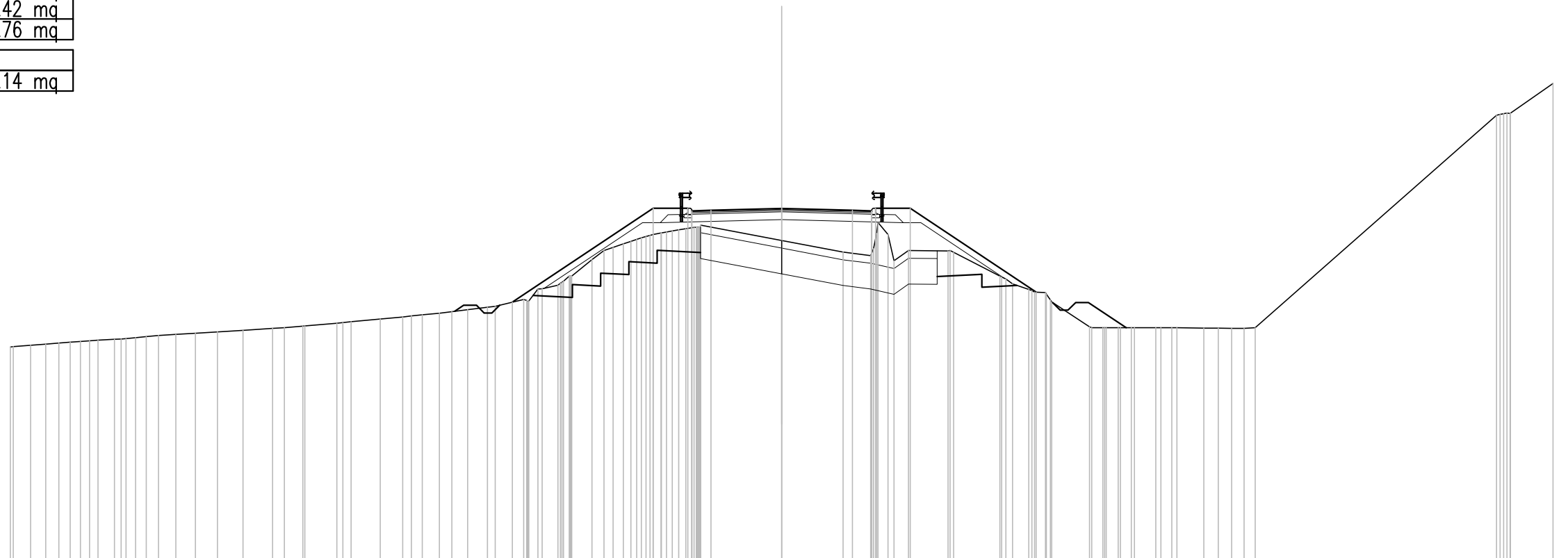

Q. PROG. STRATO SUP.																					508.51 508.34 508.36	508.63	508.56 508.54 508.51																																															
Q. PROG. STR. SUP. TER. VEG.																					504.99		508.64	508.64	508.64	505.38																																												
QUOTE TERRENO	503.25	503.26	503.27	503.31	503.36	503.40	503.46	503.51	503.55	503.58	503.65	503.69	503.73	503.78	503.83	503.90	503.97	504.00	504.06	504.07	504.17	504.23	504.33	504.41	504.50	504.56	504.62	504.70	504.79	504.83	505.10	505.50	505.65	506.00	507.00	507.25	507.43	507.53	507.88	507.80	507.90	507.99	507.39	506.94	506.80	507.62	507.00	506.98	506.93	506.00	505.70	505.48	505.37	505.00	504.03	504.00	504.00	504.00	504.00	504.00	504.00	503.98	503.98	503.97	503.97	504.00	512.26	512.33	512.33	513.49
DISTANZE PARZIALI STRATO SUP.																					0.75	2.75	2.75	0.75																																														
DISTANZE PROG STRATO SUP.																					-10.48		-5.00	-3.65		-9.89																																												
DISTANZE TERRENO	-30.00	-29.89	-29.21	-28.63	-28.12	-27.28	-26.60	-25.96	-25.30	-24.71	-24.24	-23.57	-22.81	-21.95	-20.96	-19.91	-19.34	-18.63	-18.55	-17.31	-16.75	-15.62	-14.75	-13.98	-13.32	-12.83	-12.22	-11.45	-11.14	-10.04	-9.49	-8.70	-8.25	-8.17	-6.91	-6.16	-5.64	-5.04	-4.68	-4.01	-3.41	-3.15	0.00	-2.39	3.46	4.13	4.93	6.47	6.68	8.48	8.98	9.61	10.26	11.97	12.49	13.09	13.60	13.72	14.55	15.17	15.37	16.42	16.98	17.50	17.98	18.42	27.80	28.33	28.33	30.00

SCAVI E BONIFICHE	
SCOTICO	8.78 m
BONIFICA	8.78 mq
FOSSO (SEZ. OBBL.)	0.82 mq
SCAVO A GRADONI	14.04 m
GRADONI SCAVO	10.71 mq

RILEVATI	
RILEVATO	12.55 mq
TERRENO VEGETALE	4.62 mq

SOVRASTRUTTURA STRADALE	
STRATO DI USURA	0.20 mq
STRATO DI BINDER	0.28 mq
STRATO DI BASE	0.42 mq
STRATO DI FONDAZIONE	2.76 mq

MANUFATTI	
MAGRONE	0.14 mq

SEZIONE N. : 32
 QT. PROGETTO : 510.215
 DIST.PROG. : 0+266.905
 DIST.PREC. : 6.905
 DIST.SUCC. : 3.095

SCALA 1:200

QT.RIF. 495.000

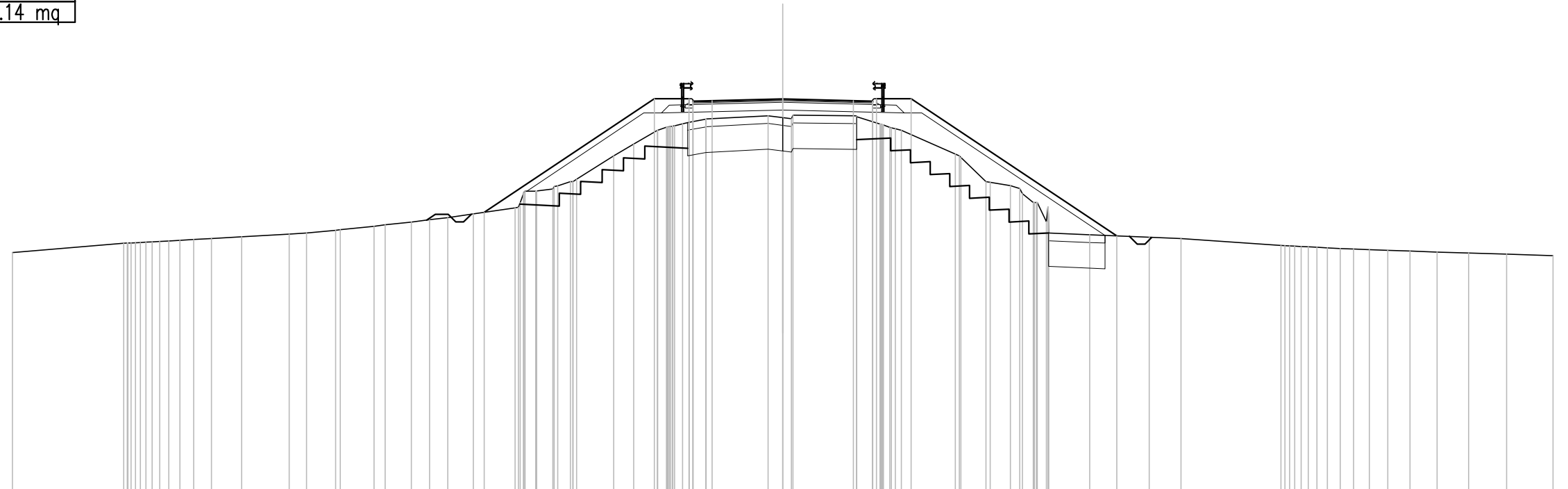

Q. PROG. STRATO SUP.																													510.10	510.13	510.15	510.21	510.15	510.10																													
Q. PROG. STR. SUP. TER. VEG.																													510.23	510.23	510.23	510.23	510.23	510.23																													
QUOTE TERRENO	504.24	504.60	504.62	504.66	504.69	504.75	504.78	504.85	504.96	505.00	505.11	505.13	505.26	505.32	505.42	505.52	505.60	505.74	505.80	505.98	506.63	506.72	507.00	508.00	508.46	509.00	509.14	509.25	509.31	509.43	509.56	509.49	509.58	509.56	509.53	509.24	509.06	509.00	508.07	507.94	507.00	506.97	506.84	506.53	506.18	505.44	505.00	504.93	504.84	504.78	504.52	504.49	504.46	504.42	504.40	504.38	504.36	504.33	504.30	504.26	504.22	504.18	504.12
DISTANZE PARZIALI STRATO SUP.																													0.75	2.75	2.75	0.75																															
DISTANZE PROG STRATO SUP.																													-11.63	-5.00	-3.65	-3.65	-5.00	13.00																													
DISTANZE TERRENO	-30.00	-25.67	-25.21	-24.56	-23.92	-22.95	-22.25	-21.07	-19.23	-18.55	-17.42	-15.92	-15.48	-14.46	-13.75	-13.05	-12.06	-10.43	-9.62	-8.95	-8.27	-8.03	-6.59	-5.81	-4.88	-4.42	-3.91	-3.65	-2.99	-0.58	0.00	0.39	2.88	3.79	4.39	4.62	6.72	6.93	7.91	8.08	8.87	9.33	9.80	10.27	10.35	11.95	14.27	15.51	19.40	19.94	20.47	21.21	21.71	22.23	22.84	23.57	24.43	25.48	26.71	28.19	30.00		

SCAVI E BONIFICHE	
FOSSO (SEZ. OBBL.)	0.27 mq
SBANCAMENTO MURO	12.03 mq
RILEVATI	
RILEVATO	52.25 mq
TERRENO VEGETALE	2.52 mq
MANUFATTI	
MAGRONE	0.14 mq

SEZIONE N. : 42
 QT. PROGETTO : 516.587
 DIST.PROG. : 0+347.811
 DIST.PREC. : 7.811
 DIST.SUCC. : 2.189

SCALA 1:200

QT.RIF. 498.000

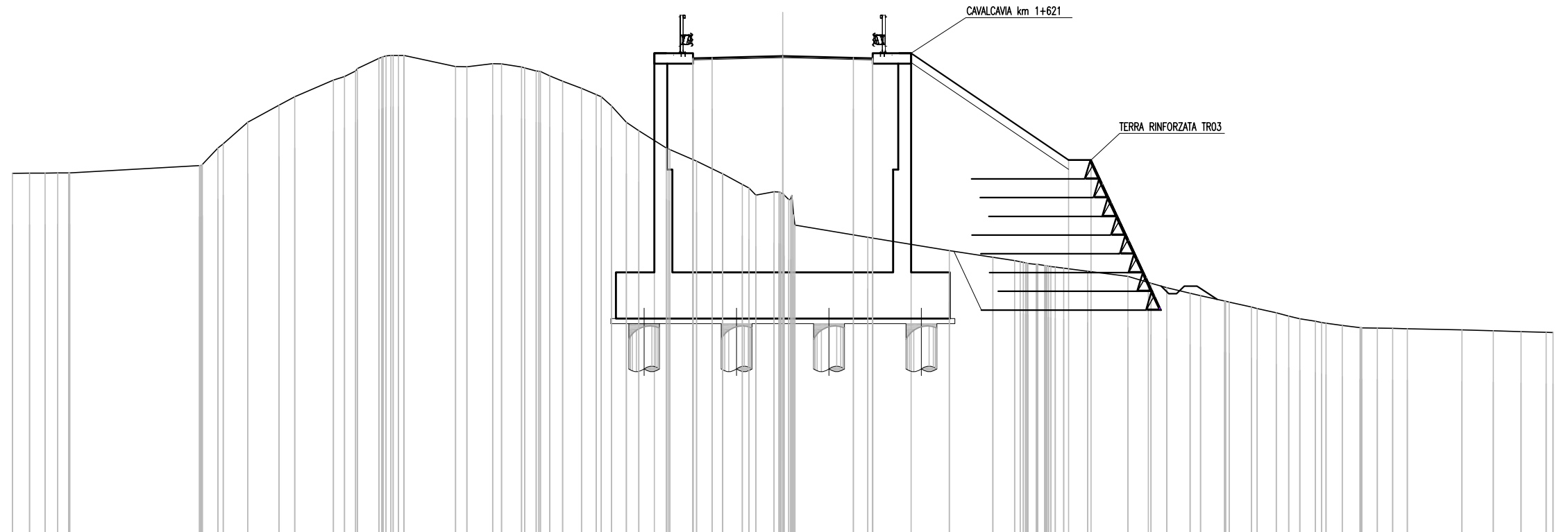

Q. PROG. STRATO SUP.	516.47 516.30 516.32 516.59 516.52 516.50 516.47																																																																				
Q. PROG. STR. SUP. TER. VEG.																																																																					
QUOTE TERRENO	512.01	512.02	512.02	512.03	512.03	512.31	513.00	513.17	514.00	514.66	515.00	515.65	516.00	516.10	516.53	516.61	516.60	516.16	516.16	516.29	516.28	516.15	516.00	515.81	515.60	515.32	515.00	514.00	513.67	513.00	512.94	512.49	512.00	512.00	511.44	511.17	511.30	510.99	510.00	509.52	509.00	508.74	508.61	508.51	508.42	508.32	508.20	508.00	507.73	507.56	507.35	507.25	507.04	507.00	506.81	506.75	506.58	506.45	506.26	506.09	506.00	505.99	505.97	505.96	505.91	505.88	505.85	505.82	505.81
DISTANZE PARZIALI STRATO SUP.	0.75 2.75 2.75 0.75																																																																				
DISTANZE PROG STRATO SUP.	-7.27 -5.00 -3.65 -3.65 -5.00 11.19 11.13 12.01 14.24																																																																				
DISTANZE TERRENO	-30.00	-29.34	-28.74	-28.43	-27.77	-22.72	-22.00	-21.80	-20.84	-19.63	-19.01	-17.50	-16.64	-16.57	-16.62	-16.17	-14.75	-12.74	-12.30	-11.30	-10.95	-10.17	-9.60	-9.08	-8.57	-7.84	-7.07	-6.09	-5.61	-4.54	-4.40	-3.36	-2.34	-2.34	-1.31	-1.05	-0.34	0.23	0.48	3.31	6.49	8.18	9.03	9.51	10.20	10.94	11.88	13.44	14.34	14.96	15.87	16.27	17.21	17.39	18.25	18.48	19.22	19.71	20.74	21.79	22.48	23.16	23.75	24.32	26.45	27.67	28.76	29.73	30.00

SEZIONE N. : 45
 QT. PROGETTO : 516.730
 DIST.PROG. : 0+393.646
 DIST.PREC. : 3.158
 DIST.SUCC. : 6.354

SCALA 1:200

QT.RIF. 500.000

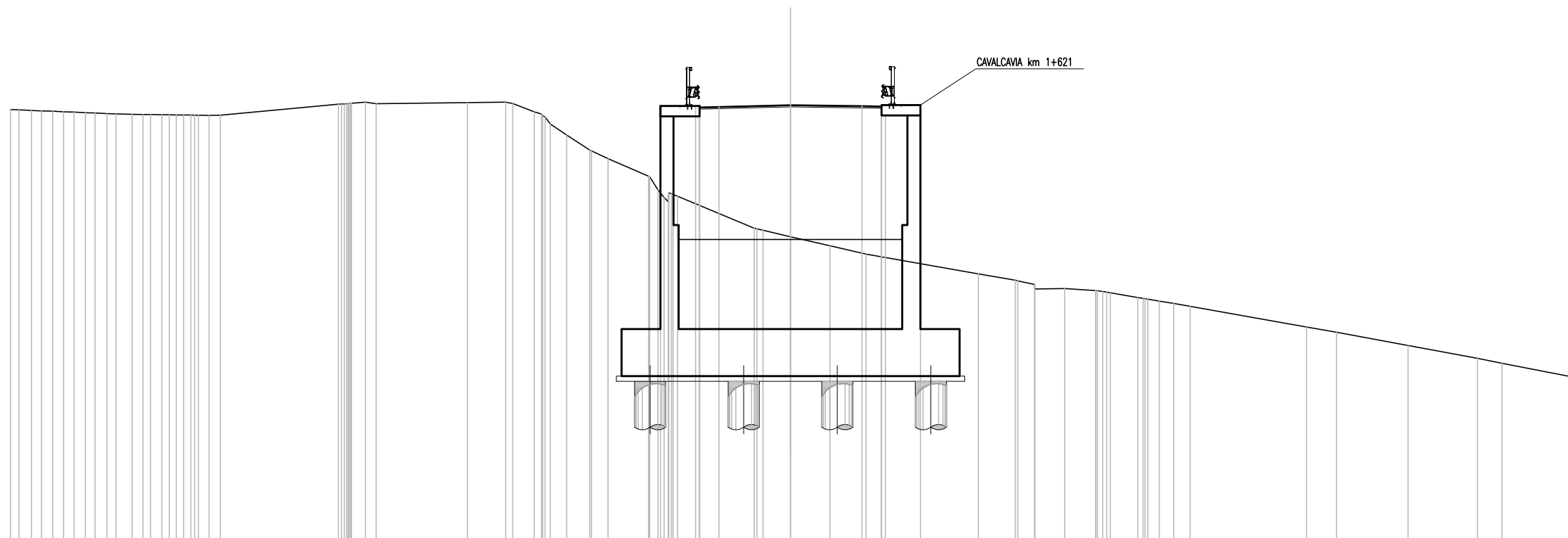

Q. PROG. STRATO SUP.	516.61 516.64 516.66 516.73 516.69 516.68 516.65																																																		
Q. PROG. STR. SUP. TER. VEG.	514.97 516.74 516.74 516.78 516.78 509.52																																																		
QUOTE TERRENO	516.56	516.55	516.52	516.49	516.46	516.42	516.38	516.37	516.36	516.35	516.34	516.34		516.76	516.79	516.84	516.78	516.83	516.84	516.79	516.47	516.00	515.58	515.00	514.67	514.00	513.18	513.22	512.00	511.92	511.67	511.32	511.00	510.24	510.00	509.98	509.96	509.68	509.60	509.54	509.34	509.20	509.11	509.00	508.20	508.00	507.49	507.00	506.81	506.30	
DISTANZE PARZIALI STRATO SUP.	0.75 2.75 2.75 0.75																																																		
DISTANZE PROG STRATO SUP.	-7.66 -5.00 -3.65 -3.65 -5.00 -12.30																																																		
DISTANZE TERRENO	-30.00	-28.68	-29.20	-28.38	-27.56	-26.75	-26.29	-25.32	-24.61	-23.90	-23.35	-22.77	-21.93		-17.39	-16.93	-16.35	-15.93	-12.42	-10.96	-10.68	-9.85	-9.24	-8.61	-7.72	-7.02	-5.46	-4.87	-4.35	-1.40	-1.06	0.00	1.52	2.91	7.23	8.64	8.75	9.40	10.55	11.74	12.16	13.36	14.19	14.74	15.37	19.85	21.00	23.75	26.42	27.37	30.00

SEZIONE N. : 46
 QT. PROGETTO : 516.730
 DIST.PROG. : 0+400.000
 DIST.PREC. : 6.354
 DIST.SUCC. : 10.000

SCAVI E BONIFICHE	
FOSSO (SEZ. OBBL.)	0.35 mq
SBANCAMENTO MURO	9.59 mq
RILEVATI	
RILEVATO	42.30 mq
TERRENO VEGETALE	2.99 mq
MANUFATTI	
MAGRONE	0.13 mq

SCALA 1:200

QT.RIF. 499.000

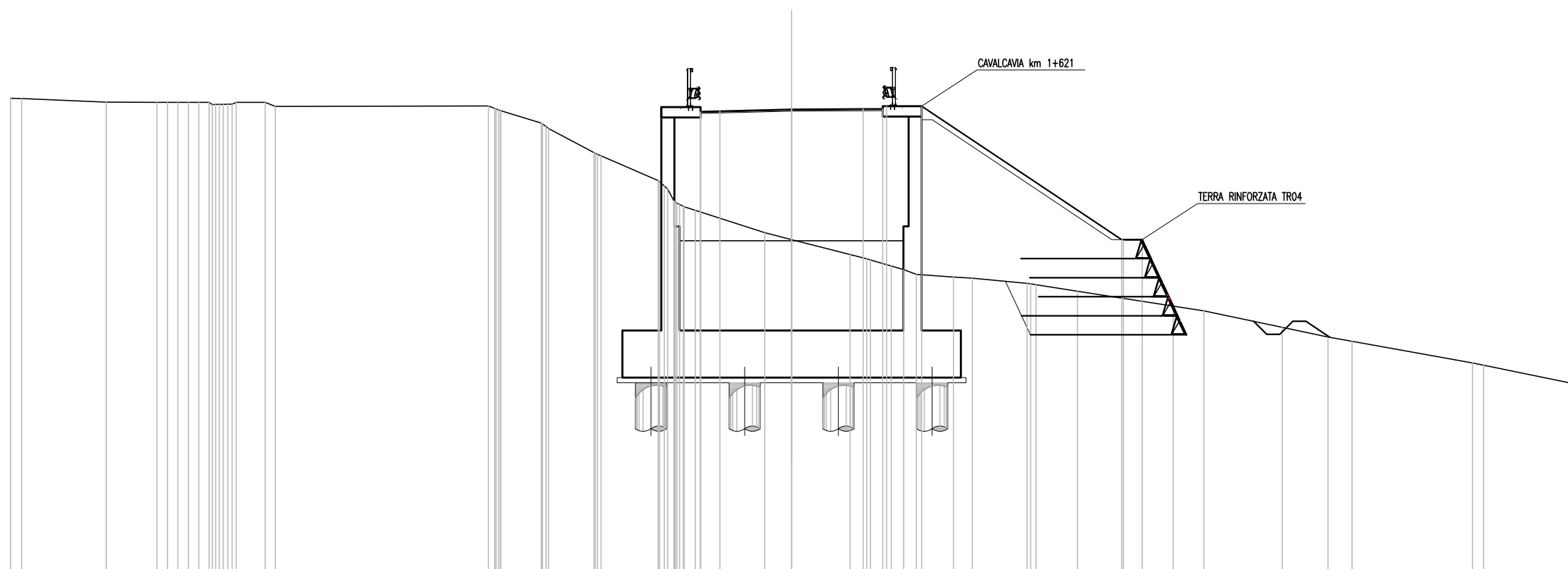

Q. PROG. STRATO SUP.	516.61 516.64 516.66 516.73 516.75 516.75 516.72																																																
Q. PROG. STR. SUP. TER. VEG.	516.85 511.73 511.73 511.73 509.18																																																
QUOTE TERRENO	517.15 517.15	517.01	517.00	517.00	517.00	516.92	516.93	517.00	517.00	516.85	516.88	516.88	516.68	516.20	516.00	515.07	514.95	514.00	513.22	512.86	512.00	511.74	511.16	511.00	510.96	510.72	510.58	510.40	510.30	510.25	510.06	510.00	509.75	511.73	511.73	511.73	509.18	509.00	508.37	508.00	507.83	507.00	506.91	506.21					
DISTANZE PARZIALI STRATO SUP.	0.75																		2.75	2.75	0.75																												
DISTANZE PROG STRATO SUP.																			-7.54	-5.00	-3.65															12.68	12.75	13.47	14.66										
DISTANZE TERRENO	-30.00	-29.58	-26.32	-24.38	-23.57	-22.77	-22.25	-21.66	-21.33	-20.22	-19.83	-11.65	-11.19	-11.17	-9.61	-9.34	-7.59	-7.32	-5.13	-4.52	-3.70	-1.03	0.00	2.25	2.88	3.03	3.83	4.31	4.79	6.22	6.94	9.05	9.39	10.98	12.68	12.75	13.47	14.66	15.84	18.85	20.60	21.53	26.15	26.58	30.00				

