

QUADRO D'UNIONE

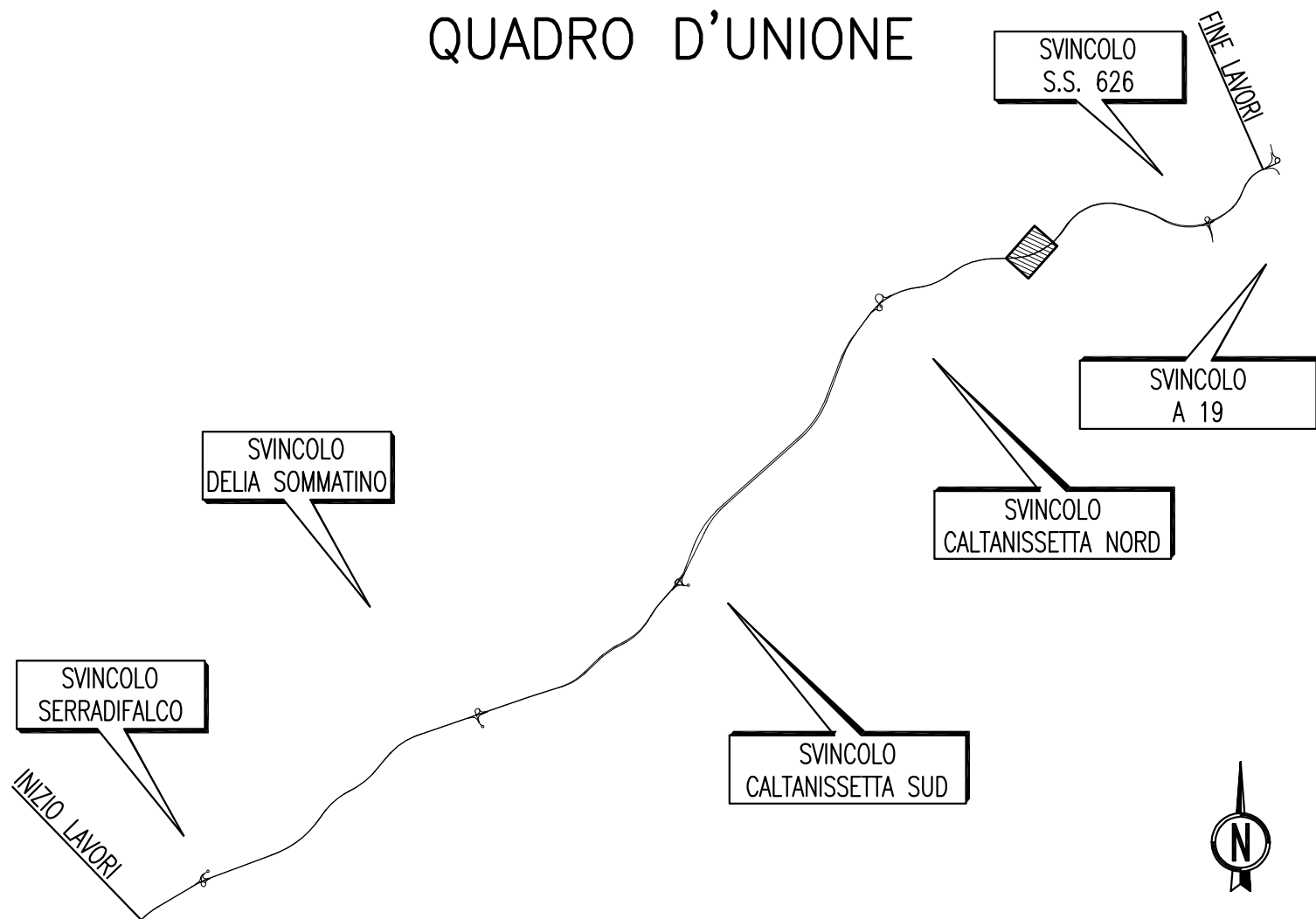

ANAS S.p.A.

DIREZIONE CENTRALE PROGRAMMAZIONE PROGETTAZIONE

PA 12/09
 CORRIDOIO PLURIMODALE TIRRENICO - NORD EUROPA
 ITINERARIO AGRIGENTO - CALTANISSETTA - A19
 S.S. N° 640 "DI PORTO EMPEDOCLE"
 AMMODERNAMENTO E ADEGUAMENTO ALLA CAT. B DEL D.M. 5.11.2001
 Dal km 44+000 allo svincolo con l'A19

PROGETTO ESECUTIVO

Contraente Generale:



INTERSEZIONI E SVINCOLI - VIABILITA' INTERFERITA VIABILITA' - Sezioni trasversali

Sezioni Trasversali - Viabilità Complementare - Tronco 43

Codice Unico Progetto (CUP) : F91B09000070001

Codice Elaborato:

PA12_09 - E 0 0 0 G E 2 1 2 P V 0 6 Z W 9 0 4 4 A Scala: 1:200

F						
E						
D						
C						
B						
A	Aprile 2011	EMISSIONE	S.TERRENO	A.TURSO	M. LITI	P. PAGLINI
REV.	DATA	DESCRIZIONE	REDATTO	VERIFICATO	APPROVATO	AUTORIZZATO

Responsabile del procedimento: Ing. MAURIZIO ARAMINI

Il Progettista:



Il Consulente Specialista:



Il Geologo:



Il Coordinatore per la sicurezza in fase di progetto:



Il Direttore dei lavori:



SEZIONE N. : 1
 QT. PROGETTO : 375.846
 DIST.PROG. : 0+000.000
 DIST.SUCC. : 10.000

SCALA 1:200

QT.RIF. 362.000

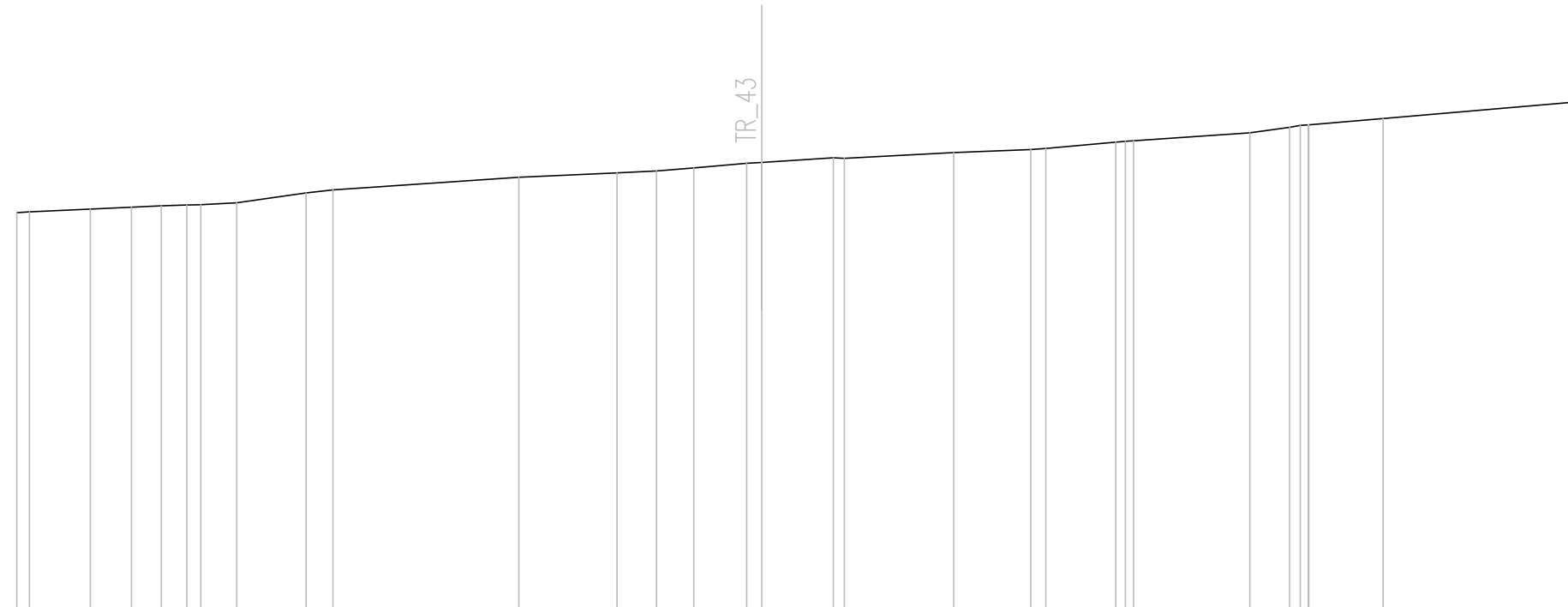

Q. PROG. STRATO SUP.	
Q. PROG. STR. SUP. TER. VEG.	
QUOTE TERRENO	374.30 374.32 374.40 374.46 374.50 374.53 374.54 374.59 374.90 375.00 375.39 375.53 375.58 375.68 375.82 375.85 375.99 375.97 376.15 376.24 376.27 376.47 376.51 376.76 376.93 377.00 377.00 377.20 377.70
DISTANZE PARZIALI STRATO SUP.	
DISTANZE PROG STRATO SUP.	
DISTANZE TERRENO	-23.00 -22.61 -20.74 -19.46 -18.55 -17.76 -17.33 -16.21 -14.07 -13.24 -7.50 -4.47 -3.26 -2.10 -0.47 0.00 2.21 2.54 5.92 8.30 8.77 10.93 11.48 15.06 16.30 16.87 16.89 19.19 25.00

SCAVI E BONIFICHE	
STERRO	1.55 mq
SCOTICO	7.99 m
BONIFICA	9.28 mq
FOSSO (SEZ. OBBL.)	1.05 mq
RILEVATI	
RILEVATO	0.47 mq
TERRENO VEGETALE	0.93 mq
SOVRASTRUTTURA STRADALE	
STRATO DI USURA	0.20 mq
STRATO DI BINDER	0.28 mq
STRATO DI BASE	0.42 mq
STRATO DI FONDAZIONE	2.43 mq
MANUFATTI	
MAGRONE	0.15 mq

SEZIONE N. : 2
 QT. PROGETTO : 375.929
 DIST.PROG. : 0+010.000
 DIST.PREC. : 10.000
 DIST.SUCC. : 10.000

SCALA 1:200

QT.RIF. 362.000

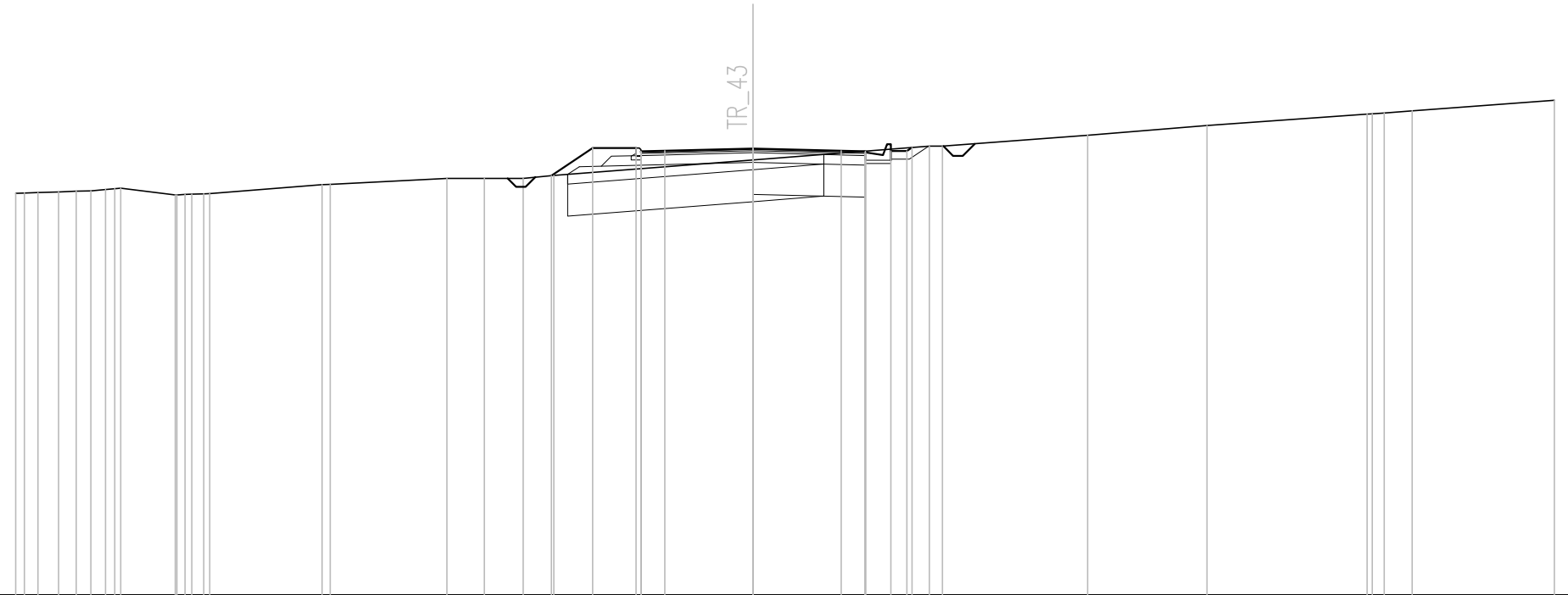

Q. PROG. STRATO SUP.								375.81	375.84	375.86		375.81																																						
Q. PROG. STR. SUP. TER. VEG.								375.94	375.94			375.85	375.85	375.96																																				
QUOTE TERRENO	374.53	374.54	374.56	374.58	374.59	374.81	374.69		374.48	374.51	374.52		374.80	374.81		375.00	375.00	375.00	375.09	375.94	375.94	375.85	375.96		376.00	376.00		376.34		376.65		377.00	377.04	377.10		377.43														
DISTANZE PARZIALI STRATO SUP.														0.75	2.75																																			
DISTANZE PROG STRATO SUP.																																																		
DISTANZE TERRENO	-23.00	-22.73	-22.30	-21.66	-21.12	-20.86	-20.20	-19.73		-18.02	-17.51	-16.95		-13.44	-13.19		-9.55	-8.38	-7.17	-6.21	-5.00	-3.65														0.00		-5.51	4.80	4.96		10.44		14.16		19.16	19.69	20.57		25.00

SCAVI E BONIFICHE	
STERRO	0.36 mq
SCOTICO	12.11 m
BONIFICA	12.16 mq
FOSSO (SEZ. OBBL.)	1.06 mq
RILEVATI	
RILEVATO	3.92 mq
TERRENO VEGETALE	1.70 mq
SOVRASTRUTTURA STRADALE	
STRATO DI USURA	0.20 mq
STRATO DI BINDER	0.28 mq
STRATO DI BASE	0.42 mq
STRATO DI FONDAZIONE	2.76 mq
MANUFATTI	
MAGRONE	0.14 mq

SEZIONE N. : 3
 QT. PROGETTO : 375.999
 DIST.PROG. : 0+020.000
 DIST.PREC. : 10.000
 DIST.SUCC. : 10.000

SCALA 1:200

QT.RIF. 362.000

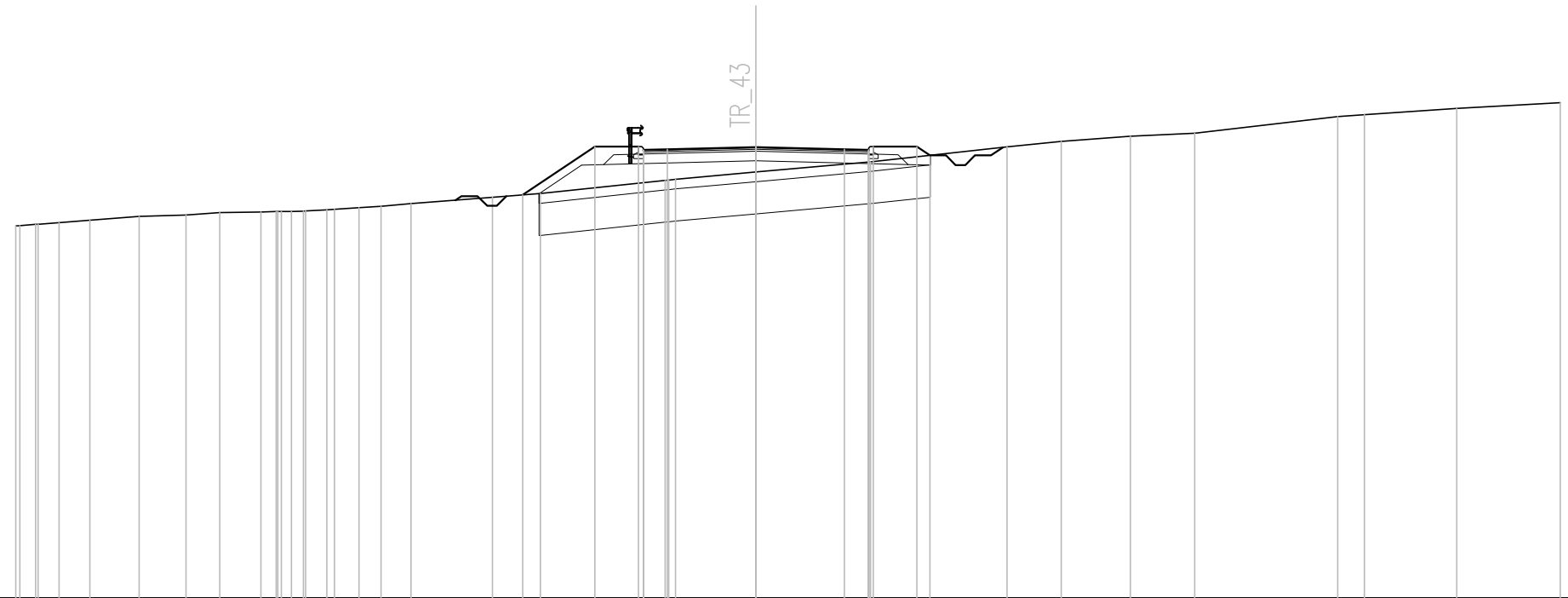

Q. PROG. STRATO SUP.								375.88 375.91 375.93																																								
Q. PROG. STR. SUP. TER. VEG.										374.51				376.01																																		
QUOTE TERRENO	373.55	373.60	373.60	373.65	373.72		373.84		373.89		373.96		373.98	374.00	374.00	374.01		374.05	374.07	374.11	374.15	374.24		374.44	374.55			374.96	375.00		375.22		375.54		376.00	376.17	376.33	376.43		376.95	377.00		377.20		377.38			
DISTANZE PARZIALI STRATO SUP.																																																
DISTANZE PROG STRATO SUP.																																																
DISTANZE TERRENO	-23.00	-22.38	-22.30	-21.66	-20.70		-19.17		-17.71		-16.66		-15.38	-14.90	-14.90	-14.00		-13.34	-13.10	-12.33	-11.65	-10.72		-8.19	-6.70			-2.82	-2.50		0.00		-3.56		7.80		9.49		11.64		13.64		18.08	18.91		21.78		25.00

SCAVI E BONIFICHE	
STERRO	0.13 mq
SCOTICO	13.56 m
BONIFICA	13.55 mq
FOSSO (SEZ. OBBL.)	1.08 mq

RILEVATI	
RILEVATO	8.51 mq
TERRENO VEGETALE	2.05 mq

SOVRASTRUTTURA STRADALE	
STRATO DI USURA	0.20 mq
STRATO DI BINDER	0.28 mq
STRATO DI BASE	0.42 mq
STRATO DI FONDAZIONE	2.76 mq

MANUFATTI	
MAGRONE	0.14 mq

SEZIONE N. : 4
 QT. PROGETTO : 376.021
 DIST.PROG. : 0+030.000
 DIST.PREC. : 10.000
 DIST.SUCC. : 10.000

SCALA 1:200

QT.RIF. 362.000

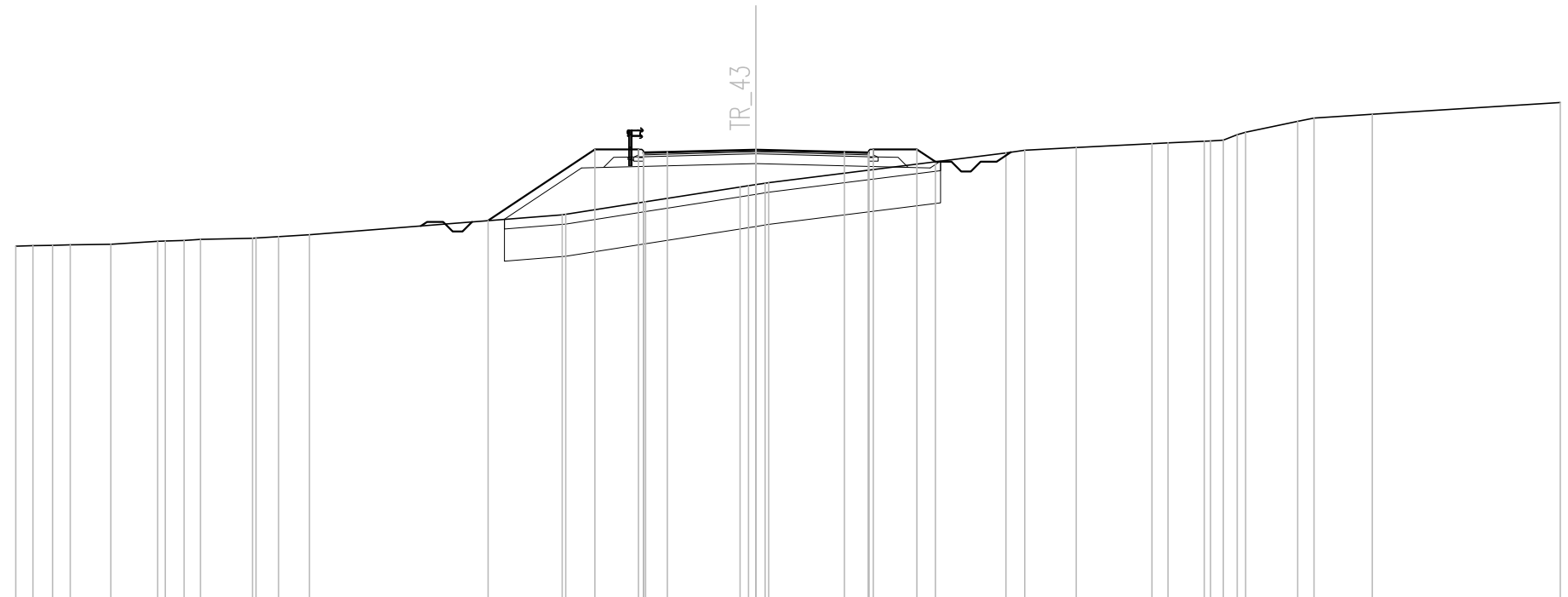

Q. PROG. STRATO SUP.						375.90	375.93	375.95	375.95									
Q. PROG. STR. SUP. TER. VEG.				373.82		376.03	376.03	376.03	376.03	376.03	375.65							
QUOTE TERRENO	373.02	373.04	373.05	373.06	373.08	373.18	373.20	373.23	373.27	373.28	373.32	373.38						
DISTANZE PARZIALI STRATO SUP.									0.75	2.75	2.75	0.75						
DISTANZE PROG STRATO SUP.					-8.32		-5.00	-3.65			-3.65	-5.00	-5.58					
DISTANZE TERRENO	-23.00	-22.47	-21.86	-21.31	-20.04	-18.59	-17.77	-17.26	-15.64	-15.53	-14.83	-13.87						

SCAVI E BONIFICHE	
SCOTICO	16.66 m
BONIFICA	16.66 mq
FOSSO (SEZ. OBBL.)	1.15 mq

RILEVATI	
RILEVATO	26.31 mq
TERRENO VEGETALE	3.05 mq

SOVRASTRUTTURA STRADALE	
STRATO DI USURA	0.20 mq
STRATO DI BINDER	0.28 mq
STRATO DI BASE	0.42 mq
STRATO DI FONDAZIONE	2.76 mq

MANUFATTI	
MAGRONE	0.14 mq

SEZIONE N. : 6
 QT. PROGETTO : 375.915
 DIST.PROG. : 0+050.000
 DIST.PREC. : 10.000
 DIST.SUCC. : 10.000

SCALA 1:200

QT.RIF. 361.000

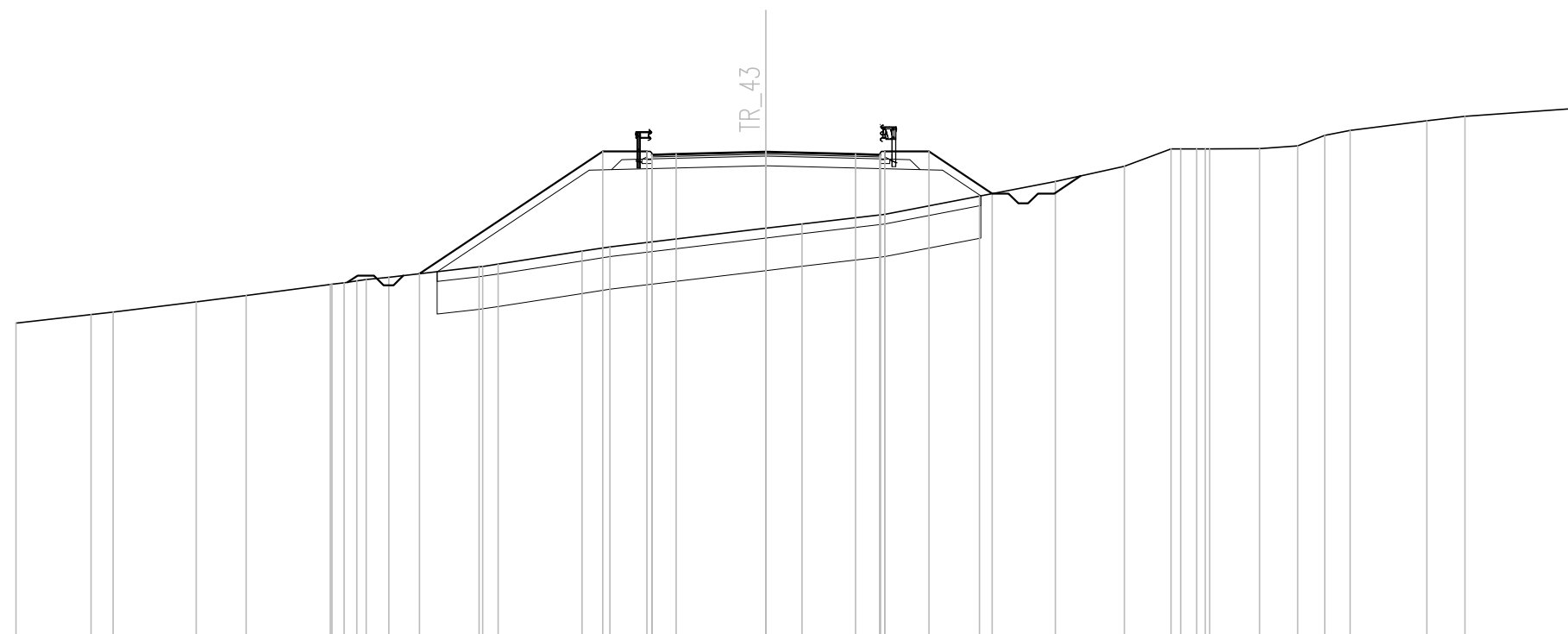

Q. PROG. STRATO SUP.										375.80	375.83	375.85	375.85	375.80																	
Q. PROG. STR. SUP. TER. VEG.						372.18				375.93	375.93			375.93	375.93	374.63															
QUOTE TERRENO	370.66	370.92	371.00	371.32	371.51	371.84	371.95	372.00	372.07	372.38	372.47	372.87	373.00	373.57	373.70	374.00	374.56	375.00	375.47	376.00	376.00	376.00	376.01	376.10	376.42	376.57	376.87	377.00	377.26		
DISTANZE PARZIALI STRATO SUP.												0.75	2.75	2.75	0.75																
DISTANZE PROG STRATO SUP.																															
DISTANZE TERRENO	-23.00	-20.70	-20.02	-17.47	-15.94	-13.36	-12.54	-12.26	-11.57	-8.79	-8.22	-5.64	-4.78	-0.00	1.11	3.64	6.55	8.88	10.99	12.43	13.21	13.61	15.15	16.31	17.14	17.92	20.28	21.44	25.00		

SCAVI E BONIFICHE	
SCOTICO	18.27 m
BONIFICA	18.27 mq
FOSSO (SEZ. OBBL.)	1.48 mq

RILEVATI	
RILEVATO	33.42 mq
TERRENO VEGETALE	3.54 mq

SOVRASTRUTTURA STRADALE	
STRATO DI USURA	0.20 mq
STRATO DI BINDER	0.28 mq
STRATO DI BASE	0.42 mq
STRATO DI FONDAZIONE	2.76 mq

MANUFATTI	
MAGRONE	0.14 mq

SEZIONE N. : 7
 QT. PROGETTO : 375.814
 DIST.PROG. : 0+060.000
 DIST.PREC. : 10.000
 DIST.SUCC. : 10.000

SCALA 1:200

QT.RIF. 360.000

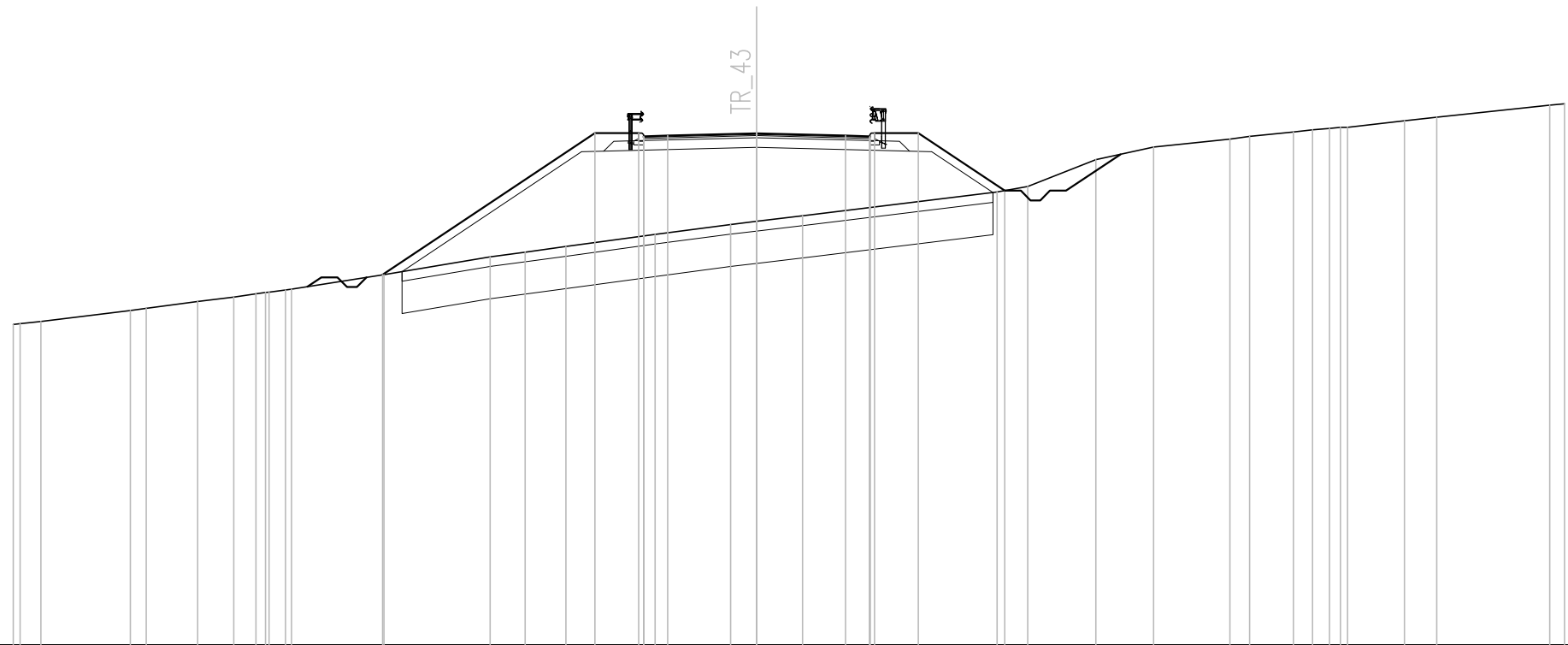

Q. PROG. STRATO SUP.											375.70	375.73	375.75	375.70																						
Q. PROG. STR. SUP. TER. VEG.												371.44																								
QUOTE TERRENO	369.90	369.93	370.00	370.34	370.40	370.61	370.76	370.85	370.98	371.00	371.45	372.00	372.15	372.31	372.69	373.00	373.10	373.27	374.00	374.17	375.00	375.39	375.64	375.72	375.85	375.92	375.97	376.00	376.21	376.32	376.69	376.73				
DISTANZE PARZIALI STRATO SUP.												0.75	2.75	2.75	0.75																					
DISTANZE PROG STRATO SUP.																																				
DISTANZE TERRENO	-23.00	-22.79	-22.14	-19.38	-18.89	-17.29	-16.18	-15.49	-14.58	-14.39	-11.53	-8.25	-7.17	-5.90	-3.14	-0.80	0.00	1.42	7.44	8.39	10.49	12.28	14.64	15.25	16.61	17.20	17.73	18.29	20.04	21.05	24.54	25.00				

SCAVI E BONIFICHE	
SCOTICO	18.91 m
BONIFICA	18.91 mq
FOSSO (SEZ. OBBL.)	1.06 mq
RILEVATI	
RILEVATO	38.79 mq
TERRENO VEGETALE	3.73 mq
SOVRASTRUTTURA STRADALE	
STRATO DI USURA	0.20 mq
STRATO DI BINDER	0.28 mq
STRATO DI BASE	0.42 mq
STRATO DI FONDAZIONE	2.76 mq
MANUFATTI	
MAGRONE	0.14 mq

SEZIONE N. : 8
 QT. PROGETTO : 375.713
 DIST.PROG. : 0+070.000
 DIST.PREC. : 10.000
 DIST.SUCC. : 10.000

SCALA 1:200

QT.RIF. 360.000

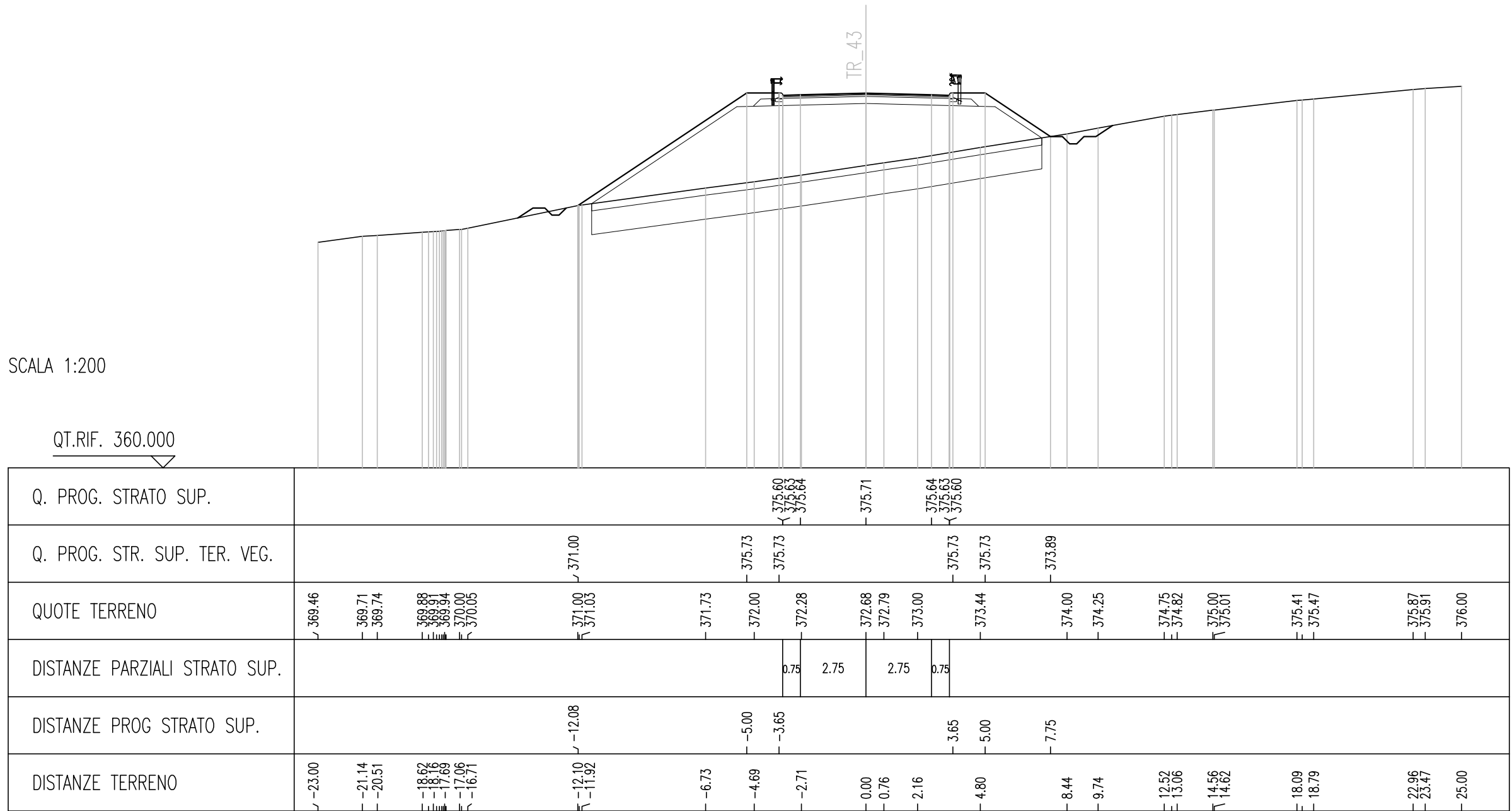

SEZIONE N. : 10
 QT. PROGETTO : 375.510
 DIST.PROG. : 0+090.000
 DIST.PREC. : 10.000
 DIST.SUCC. : 1.907

SCALA 1:200

QT.RIF. 359.000

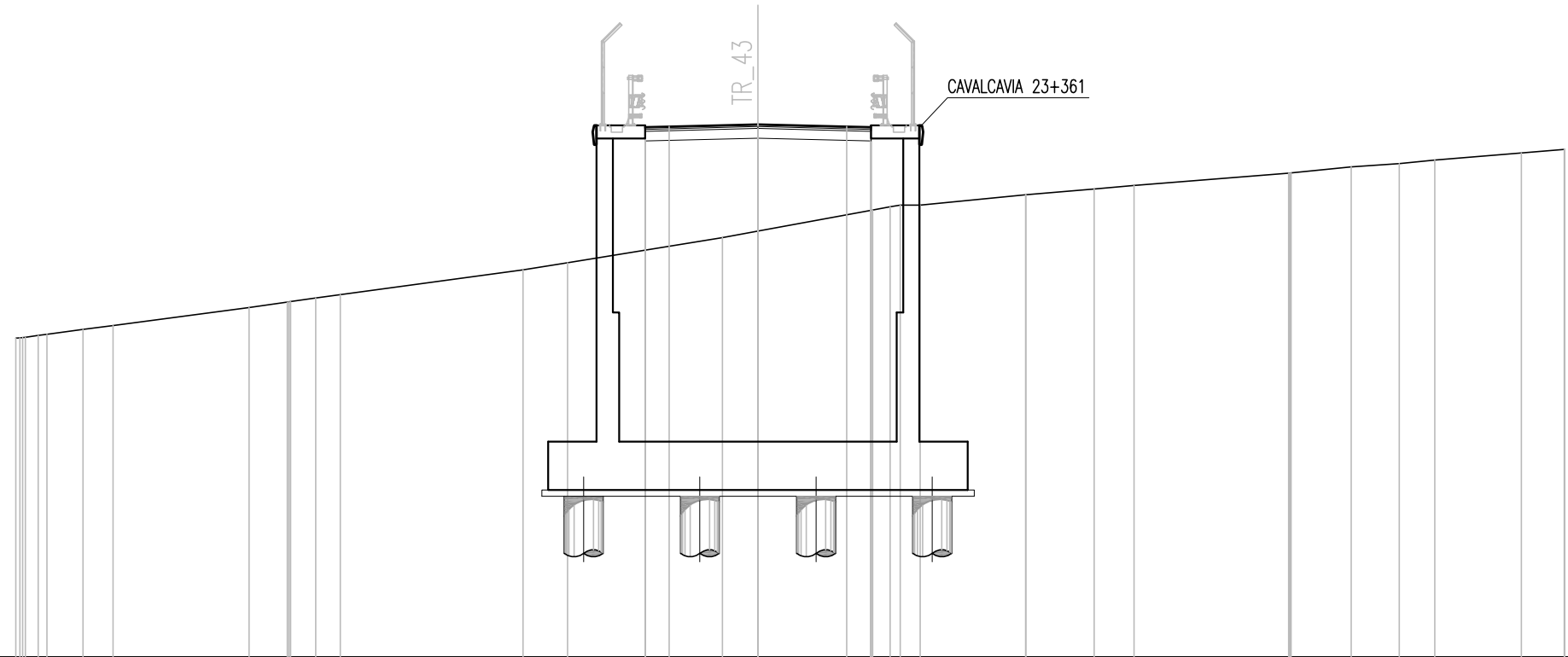

Q. PROG. STRATO SUP.								375.39	375.42	375.44			375.51		375.44	375.42	375.39																
Q. PROG. STR. SUP. TER. VEG.								375.52	375.52	375.52			375.52		375.52	375.52	375.52																
QUOTE TERRENO	368.88	368.91	369.00	369.15	369.27		369.83	370.00	370.01	370.12		371.00	371.22		372.00	372.20		372.85	372.95	373.00		373.33	373.51	373.61	373.99	374.00	374.19	374.29	374.40	374.62	374.73	374.73	
DISTANZE PARZIALI STRATO SUP.								0.75	2.75	2.75	0.75																						
DISTANZE PROG STRATO SUP.											-12.94																						
DISTANZE TERRENO	-23.00	-22.71	-22.04	-20.92	-19.99		-15.77	-14.59	-14.49	-13.70		-7.28	-5.90		-1.10	0.00		3.56	4.10	5.03		8.30	10.42	11.65	16.45	16.52	18.38	19.87	20.98	23.66	24.99	25.00	

SCAVI E BONIFICHE	
SCOTICO	21.92 m
BONIFICA	21.92 mq
FOSSO (SEZ. OBBL.)	1.11 mq
SBANCAMENTO MURO	6.06 mq

RILEVATI	
RILEVATO	122.43 mq
TERRENO VEGETALE	4.58 mq

SOVRASTRUTTURA STRADALE	
STRATO DI USURA	0.20 mq
STRATO DI BINDER	0.28 mq
STRATO DI BASE	0.42 mq
STRATO DI FONDAZIONE	2.75 mq

MANUFATTI	
MAGRONE	0.14 mq

SEZIONE N. : 14

QT. PROGETTO : 375.110

DIST.PROG. : 0+128.476

DIST.PREC. : 4.000

DIST.SUCC. : 11.524

SCALA 1:200

QT.RIF. 358.000

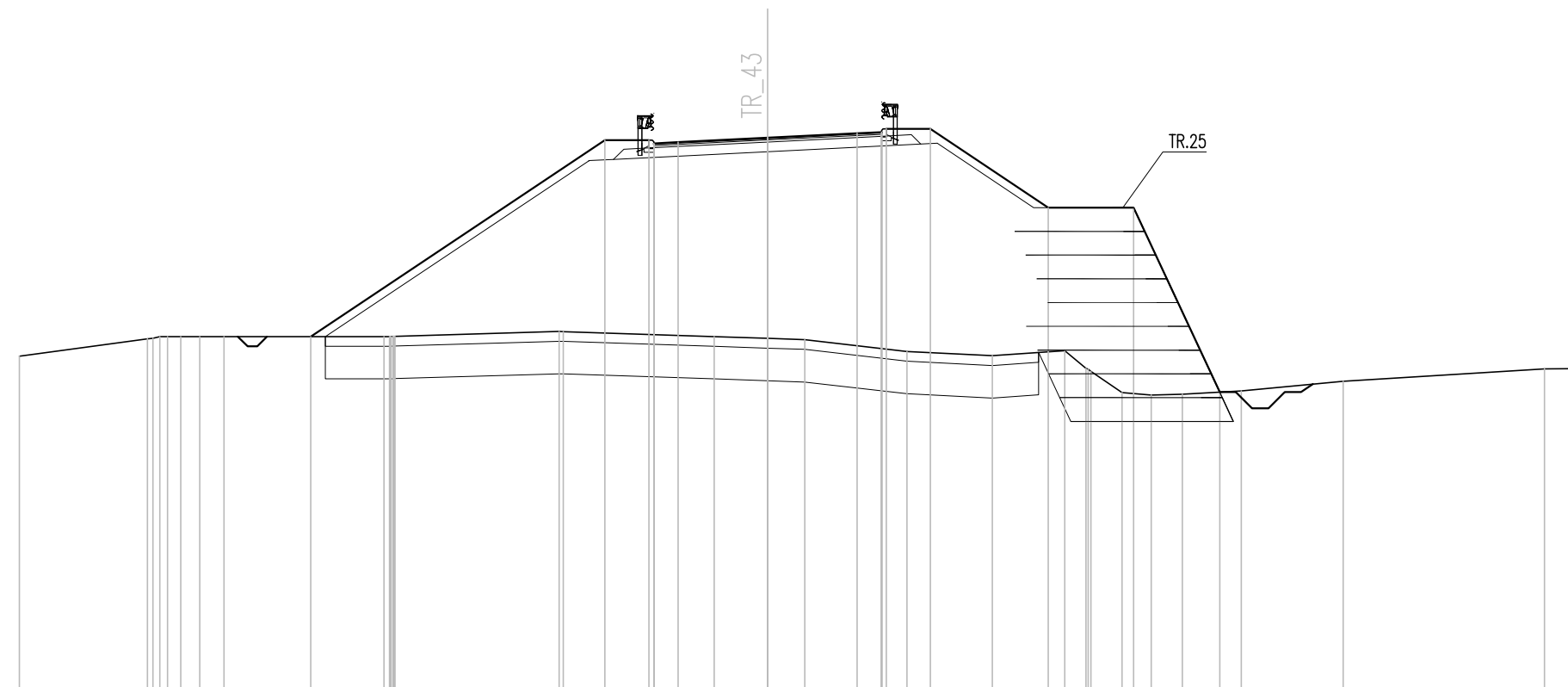

Q. PROG. STRATO SUP.						374.90	374.97		375.11		375.25	375.28	375.25													
Q. PROG. STR. SUP. TER. VEG.				369.00		375.03	375.03				375.38	375.38		372.96		372.96		367.29								
QUOTE TERRENO	368.40	368.93	369.00	369.00	369.00	369.16	369.15		369.00	368.94	368.90		368.54	368.41	368.57	368.02	367.95	367.28	367.20	367.23	367.33	367.63		368.01	368.01	
DISTANZE PARZIALI STRATO SUP.								0.75	2.75		2.75	0.75														
DISTANZE PROG STRATO SUP.				-14.05		-5.00	-3.65					-3.65	-5.00		-8.63		-11.25		-13.90							
DISTANZE TERRENO	-23.00	-19.06	-18.44			-6.41	-6.28		-1.64	-0.00	-1.14		-4.28	-6.90	-9.14	-9.78	-9.94	-10.90	-11.79	-12.75	-14.56		-17.69		-23.88	-25.00

SCAVI E BONIFICHE	
BONIFICA	26.86 mq
FOSSO (SEZ. OBBL.)	1.10 mq
SBANCAMENTO MURO	4.24 mq
RILEVATI	
RILEVATO	160.33 mq
TERRENO VEGETALE	5.21 mq
SOVRASTRUTTURA STRADALE	
STRATO DI USURA	0.20 mq
STRATO DI BINDER	0.28 mq
STRATO DI BASE	0.42 mq
STRATO DI FONDAZIONE	2.75 mq
MANUFATTI	
MAGRONE	0.14 mq

SEZIONE N. : 15
 QT. PROGETTO : 374.849
 DIST.PROG. : 0+140.000
 DIST.PREC. : 11.524
 DIST.SUCC. : 10.000

SCALA 1:200

QT.RIF. 357.000

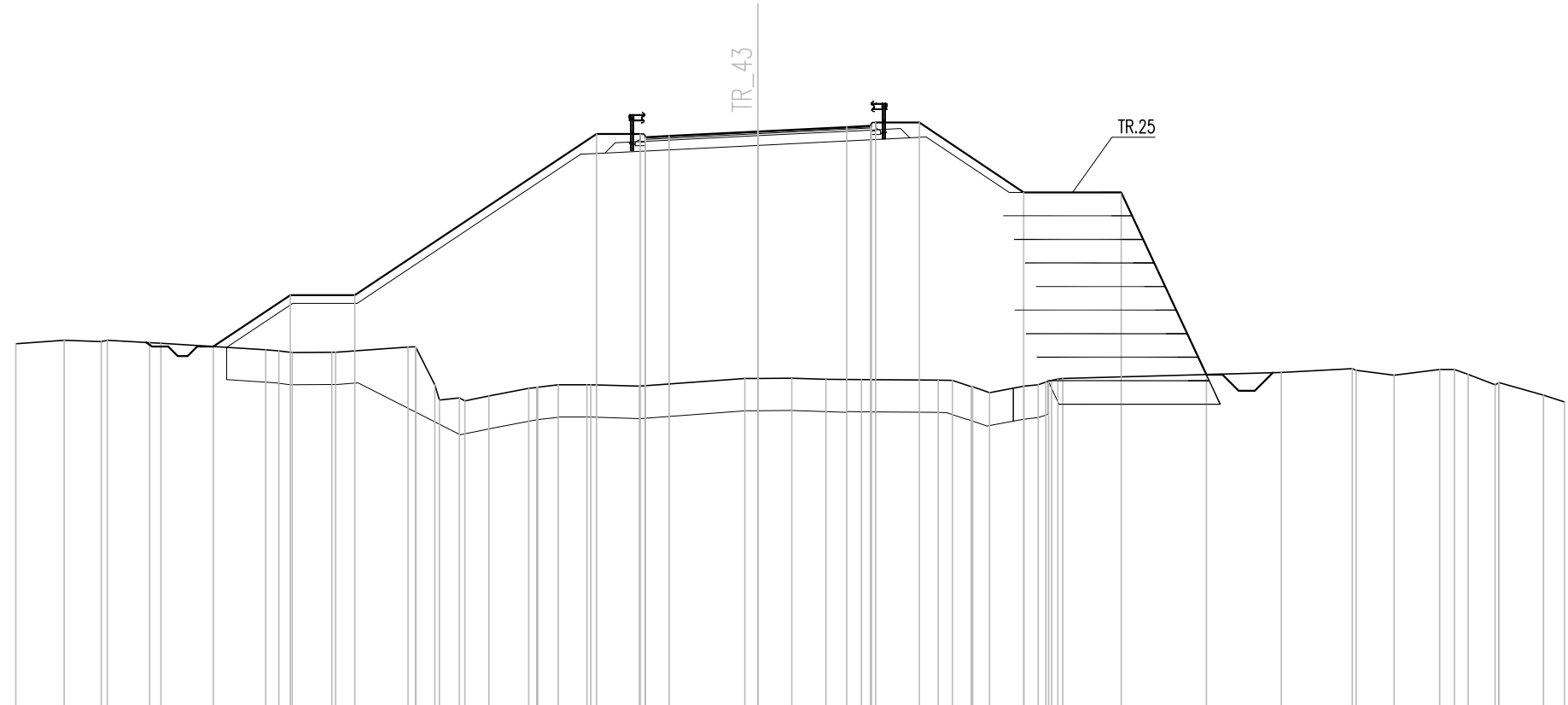

Q. PROG. STRATO SUP.	$\sqrt{374.64}$ $\sqrt{374.67}$ $\sqrt{374.71}$ $\sqrt{374.85}$ $\sqrt{374.99}$ $\sqrt{375.02}$ $\sqrt{374.99}$																																															
Q. PROG. STR. SUP. TER. VEG.	$\sqrt{368.19}$ $\sqrt{369.77}$ $\sqrt{369.77}$ $\sqrt{374.77}$ $\sqrt{374.77}$ $\sqrt{375.12}$ $\sqrt{375.12}$ $\sqrt{372.96}$ $\sqrt{372.96}$ $\sqrt{367.31}$																																															
QUOTE TERRENO	$\sqrt{368.27}$	$\sqrt{368.38}$	$\sqrt{368.34}$	$\sqrt{368.38}$	$\sqrt{368.30}$	$\sqrt{368.29}$	$\sqrt{368.08}$	$\sqrt{368.00}$	$\sqrt{368.01}$	$\sqrt{368.01}$	$\sqrt{368.17}$	$\sqrt{367.00}$	$\sqrt{366.59}$	$\sqrt{366.50}$	$\sqrt{366.65}$	$\sqrt{366.89}$	$\sqrt{366.93}$	$\sqrt{367.00}$	$\sqrt{367.00}$	$\sqrt{366.95}$	$\sqrt{367.19}$	$\sqrt{367.19}$	$\sqrt{367.20}$	$\sqrt{367.16}$	$\sqrt{367.16}$	$\sqrt{367.14}$	$\sqrt{366.94}$	$\sqrt{366.75}$	$\sqrt{366.95}$	$\sqrt{367.00}$	$\sqrt{367.18}$	$\sqrt{367.19}$	$\sqrt{367.38}$	$\sqrt{367.50}$	$\sqrt{367.45}$	$\sqrt{367.30}$	$\sqrt{367.47}$	$\sqrt{367.48}$	$\sqrt{367.32}$	$\sqrt{367.00}$	$\sqrt{367.07}$	$\sqrt{366.67}$	$\sqrt{366.47}$					
DISTANZE PARZIALI STRATO SUP.							0.75	2.75	2.75	0.75																																						
DISTANZE PROG STRATO SUP.						$\sqrt{-16.88}$	$\sqrt{-15.26}$	$\sqrt{-14.43}$	$\sqrt{-14.50}$	$\sqrt{-12.50}$						$\sqrt{-5.00}$	$\sqrt{-3.65}$			$\sqrt{-3.65}$	$\sqrt{-5.00}$	$\sqrt{-8.24}$	$\sqrt{-11.26}$	$\sqrt{-13.90}$																								
DISTANZE TERRENO	$\sqrt{-23.00}$	$\sqrt{-21.50}$	$\sqrt{-20.35}$	$\sqrt{-20.16}$	$\sqrt{-18.85}$	$\sqrt{-18.51}$					$\sqrt{-10.84}$	$\sqrt{-10.02}$	$\sqrt{-9.26}$	$\sqrt{-9.08}$	$\sqrt{-8.34}$	$\sqrt{-7.10}$	$\sqrt{-6.85}$	$\sqrt{-6.19}$	$\sqrt{-5.30}$	$\sqrt{-5.18}$	$\sqrt{-3.68}$	$\sqrt{-0.41}$	$\sqrt{0.00}$	$\sqrt{1.05}$	$\sqrt{2.11}$	$\sqrt{3.21}$	$\sqrt{5.59}$	$\sqrt{6.61}$	$\sqrt{7.18}$	$\sqrt{8.24}$	$\sqrt{8.69}$	$\sqrt{9.30}$	$\sqrt{9.45}$		$\sqrt{16.22}$	$\sqrt{18.42}$	$\sqrt{18.54}$	$\sqrt{19.72}$	$\sqrt{21.13}$	$\sqrt{21.59}$	$\sqrt{22.01}$	$\sqrt{22.85}$	$\sqrt{22.97}$	$\sqrt{24.35}$	$\sqrt{25.00}$			

SCAVI E BONIFICHE	
BONIFICA	23.10 mq
FOSSO (SEZ. OBBL.)	0.88 mq
SBANCAMENTO MURO	6.19 mq
SCAVO A GRADONI	1.47 m
GRADONI SCAVO	0.93 mq

RILEVATI	
RILEVATO	153.63 mq
TERRENO VEGETALE	5.53 mq

SOVRASTRUTTURA STRADALE	
STRATO DI USURA	0.20 mq
STRATO DI BINDER	0.28 mq
STRATO DI BASE	0.42 mq
STRATO DI FONDAZIONE	2.76 mq

MANUFATTI	
MAGRONE	0.14 mq

SEZIONE N. : 18
 QT. PROGETTO : 373.775
 DIST.PROG. : 0+163.974
 DIST.PREC. : 4.000
 DIST.SUCC. : 6.026

SCALA 1:200

QT.RIF. 355.000

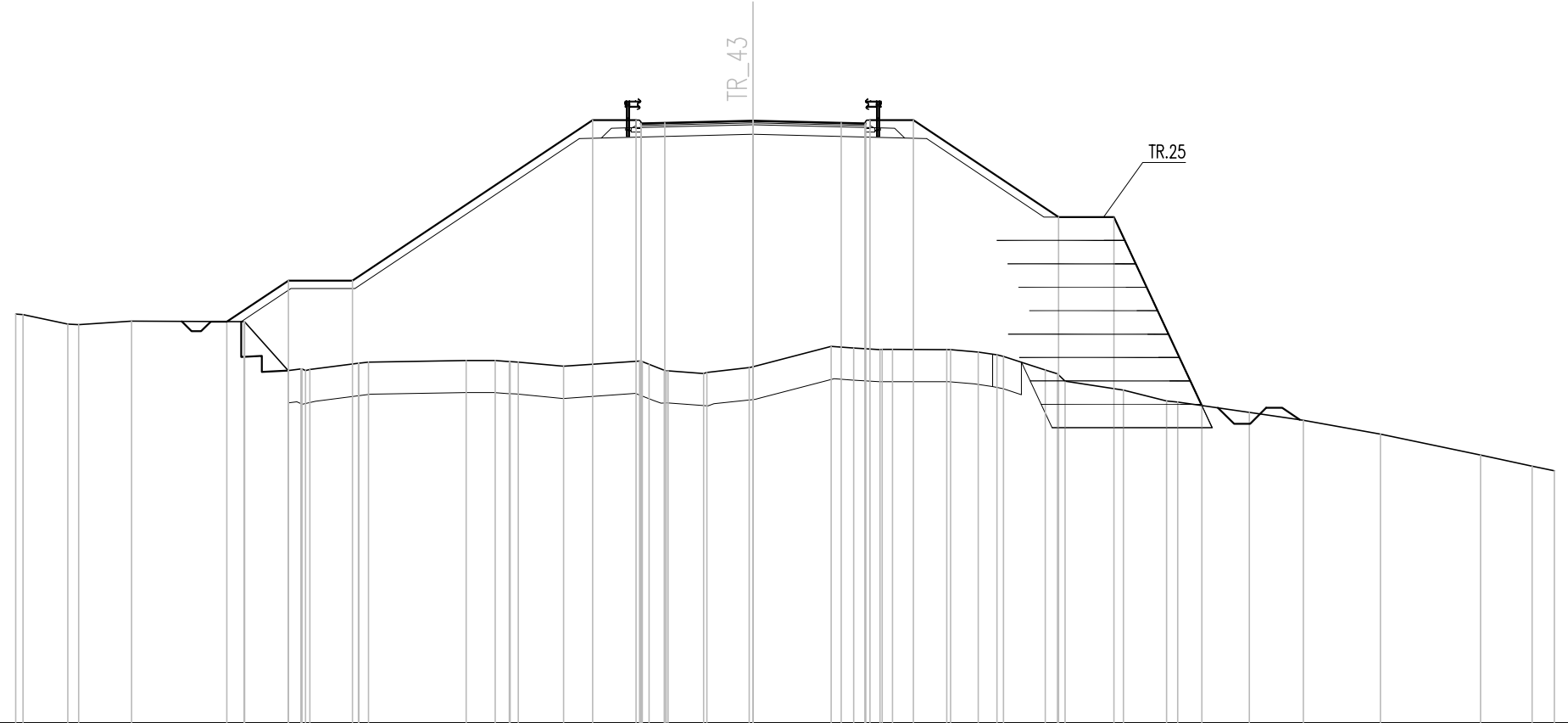

Q. PROG. STRATO SUP.	373.66 373.69 373.71 373.78 373.71 373.69 373.66																					
Q. PROG. STR. SUP. TER. VEG.	367.51 368.79 368.79 373.79 373.79 373.79 373.79 370.77 370.77 364.89																					
QUOTE TERRENO	367.75 367.73	367.43 367.41	367.52	367.50	365.98 365.98 366.01	366.21 366.25	366.30	366.30 366.26 366.25	366.12	366.28 365.99 365.97 365.89 365.93	366.07 366.10	366.73 366.68	366.64 366.64	366.64 366.63 366.56 366.47 366.42	366.00 365.65	365.37	365.03 365.00	364.67	364.43	364.00	363.34 363.00 362.85	
DISTANZE PARZIALI STRATO SUP.										0.75	2.75	2.75	0.75									
DISTANZE PROG STRATO SUP.				-16.42		-14.50				-5.00	-3.65			-3.65	-5.00			-9.53	-11.26		-14.00	
DISTANZE TERRENO	-23.00 -22.77	-21.37 -21.03	-19.38	-15.87	-14.50 -13.96 -13.82	-12.31 -11.99	-8.94	-8.04 -7.60 -7.32	-5.91	-3.54 -2.77 -2.65	-1.54 -1.44	-0.12 0.00	2.44 3.14	3.96 4.35	6.04 6.16 7.02 7.61 7.81	9.11 9.74	11.55	12.90 13.25	15.49	17.17	19.57	22.70 24.31 25.00

SCAVI E BONIFICHE	
BONIFICA	23.02 mq
FOSSO (SEZ. OBBL.)	0.87 mq
SBANCAMENTO MURO	9.07 mq

RILEVATI	
RILEVATO	144.24 mq
TERRENO VEGETALE	5.36 mq

SOVRASTRUTTURA STRADALE	
STRATO DI USURA	0.20 mq
STRATO DI BINDER	0.28 mq
STRATO DI BASE	0.42 mq
STRATO DI FONDAZIONE	2.76 mq

MANUFATTI	
MAGRONE	0.14 mq

SEZIONE N. : 19
 QT. PROGETTO : 373.392
 DIST.PROG. : 0+170.000
 DIST.PREC. : 6.026
 DIST.SUCC. : 10.000

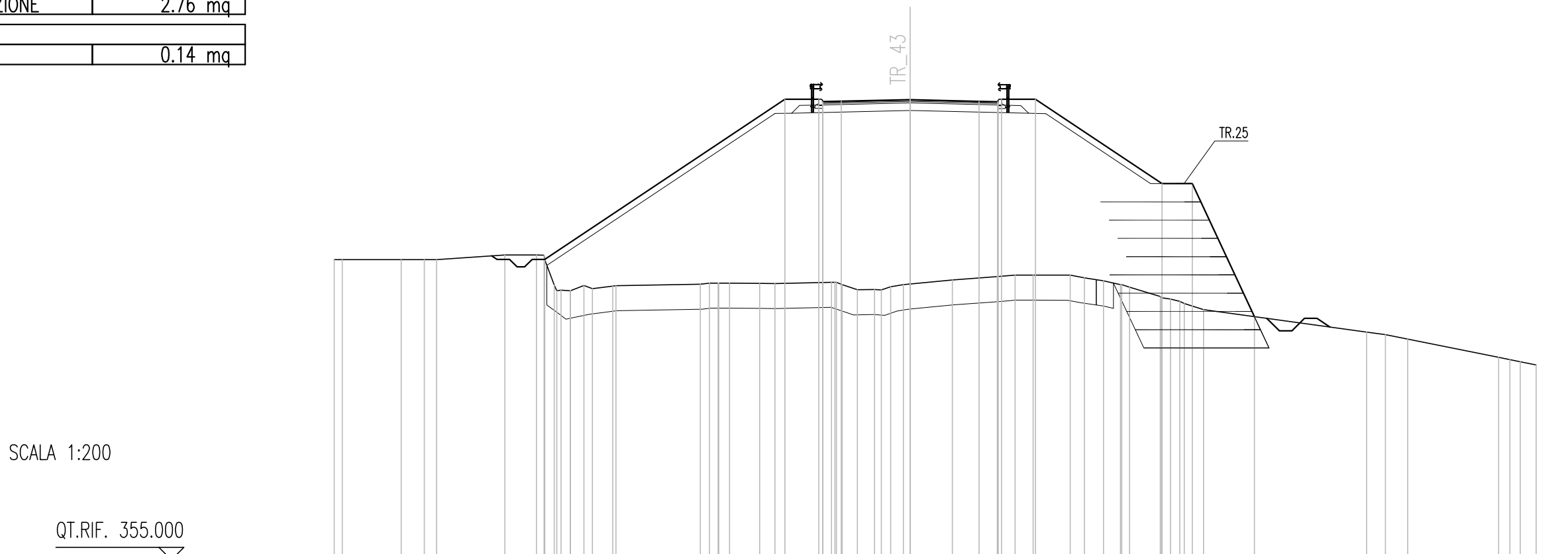

Q. PROG. STRATO SUP.								373.28							373.32																																	
Q. PROG. STR. SUP. TER. VEG.								373.33							373.31																																	
QUOTE TERRENO	367.00	367.00	367.00	367.00	367.19	367.18	365.98	365.76	365.96	365.83	365.94	365.95		366.01	366.06	366.06	366.05	366.04	373.41	373.41	373.41	373.41	373.41	373.39	373.32	373.31	373.28	366.37	366.27	366.15	366.00	365.89	365.52	365.33	365.25	365.00				364.11	364.00	363.82	363.10	363.00	362.79			
DISTANZE PARZIALI STRATO SUP.																				0.75	2.75	2.75	0.75																									
DISTANZE PROG STRATO SUP.																																																
DISTANZE TERRENO	-23.00	-22.68	-20.32	-19.41	-18.91	-16.19	-14.93	-14.22	-13.57	-13.03	-12.69	-11.88	-11.75	-8.38	-7.67	-7.22	-6.01	-5.40	-5.00	-3.65	-3.14	-2.11	-1.42	-0.78	-0.27	0.00	1.69	3.48	4.19	4.91	6.39	6.96	7.72	8.40	8.76	9.99	10.77	10.95	11.12				18.23	18.98	19.87	23.50	23.95	25.00

SCAVI E BONIFICHE	
BONIFICA	25.26 mq
FOSSO (SEZ. OBBL.)	1.30 mq
SCAVO A GRADONI	3.52 m
GRADONI SCAVO	2.31 mq
RILEVATI	
RILEVATO	70.63 mq
TERRENO VEGETALE	6.32 mq
SOVRASTRUTTURA STRADALE	
STRATO DI USURA	0.20 mq
STRATO DI BINDER	0.28 mq
STRATO DI BASE	0.42 mq
STRATO DI FONDAZIONE	2.76 mq
MANUFATTI	
MAGRONE	0.14 mq

SEZIONE N. : 26
 QT. PROGETTO : 366.820
 DIST.PROG. : 0+240.000
 DIST.PREC. : 10.000
 DIST.SUCC. : 10.000

SCALA 1:200

QT.RIF. 349.000

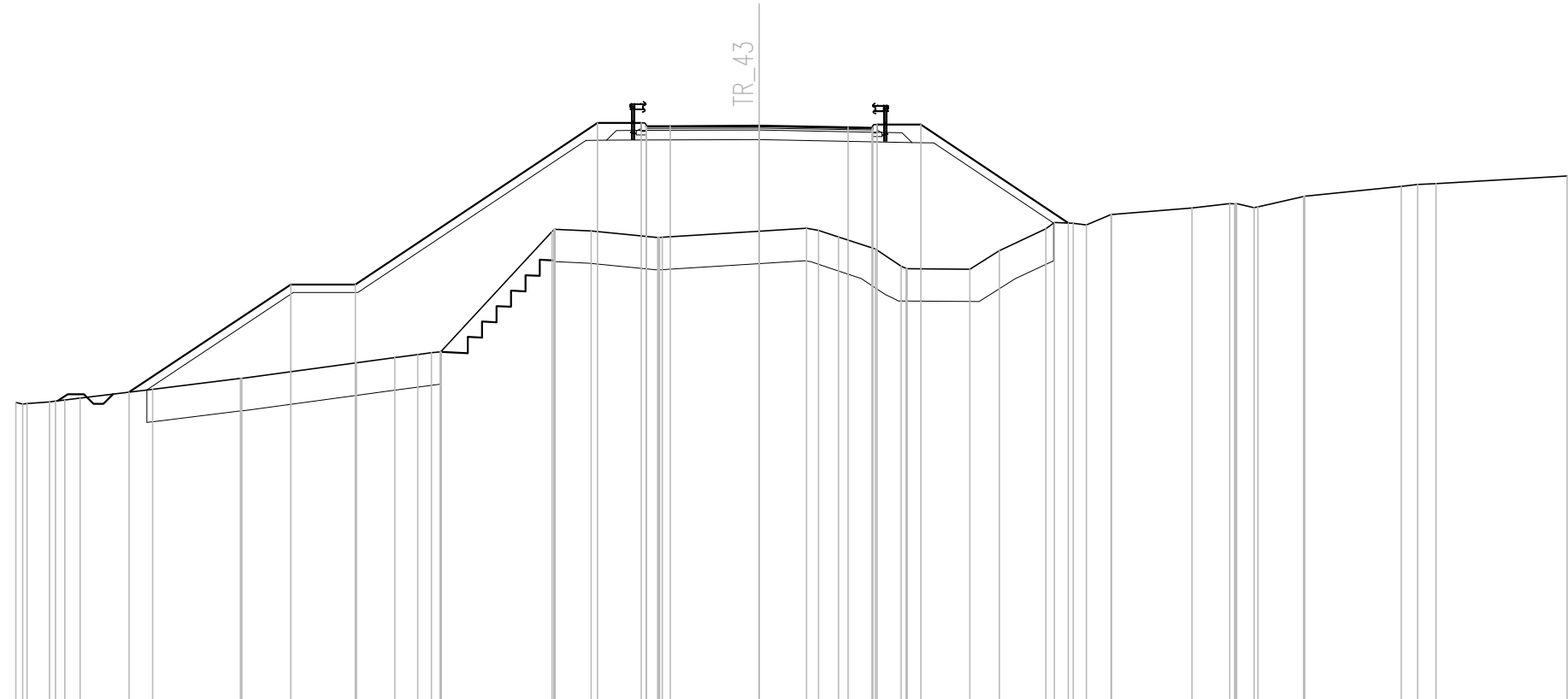

Q. PROG. STRATO SUP.								366.78	366.81	366.82		366.77	366.75	366.72																													
Q. PROG. STR. SUP. TER. VEG.			358.57					366.91	366.91				366.85	366.85				363.81																									
QUOTE TERRENO	358.25	358.22		358.66			359.00	361.55	363.62	363.56		363.36	363.37	363.56		363.65	363.38	363.00	362.47	362.39		362.38	362.96	363.63	363.80	363.75	364.07	364.07		364.27	364.41	364.28	364.31	364.63	364.64		364.94	365.00	365.02		365.26		
DISTANZE PARZIALI STRATO SUP.									0.75	2.75									0.75																								
DISTANZE PROG STRATO SUP.				-19.50					-14.50	-12.50			-5.00	-3.65					-3.65		-5.00								-9.57														
DISTANZE TERRENO	-23.00	-22.65		-18.77			-16.05	-6.41	-6.34	-5.20		-3.14	-3.00	-0.00		1.47	2.45	3.60	4.39	4.57		6.52	7.43	8.87	9.72	10.13	10.89	10.89		13.39	14.56	15.31	15.43	16.84	16.88		19.87	20.36	20.94		25.00		

SCAVI E BONIFICHE	
BONIFICA	22.68 mq
FOSSO (SEZ. OBBL.)	1.18 mq
SCAVO A GRADONI	5.50 m
GRADONI SCAVO	3.17 mq

RILEVATI	
RILEVATO	57.10 mq
TERRENO VEGETALE	6.06 mq

SOVRASTRUTTURA STRADALE	
STRATO DI USURA	0.20 mq
STRATO DI BINDER	0.28 mq
STRATO DI BASE	0.42 mq
STRATO DI FONDAZIONE	2.76 mq

MANUFATTI	
MAGRONE	0.14 mq

SEZIONE N. : 27
 QT. PROGETTO : 365.820
 DIST.PROG. : 0+250.000
 DIST.PREC. : 10.000
 DIST.SUCC. : 10.000

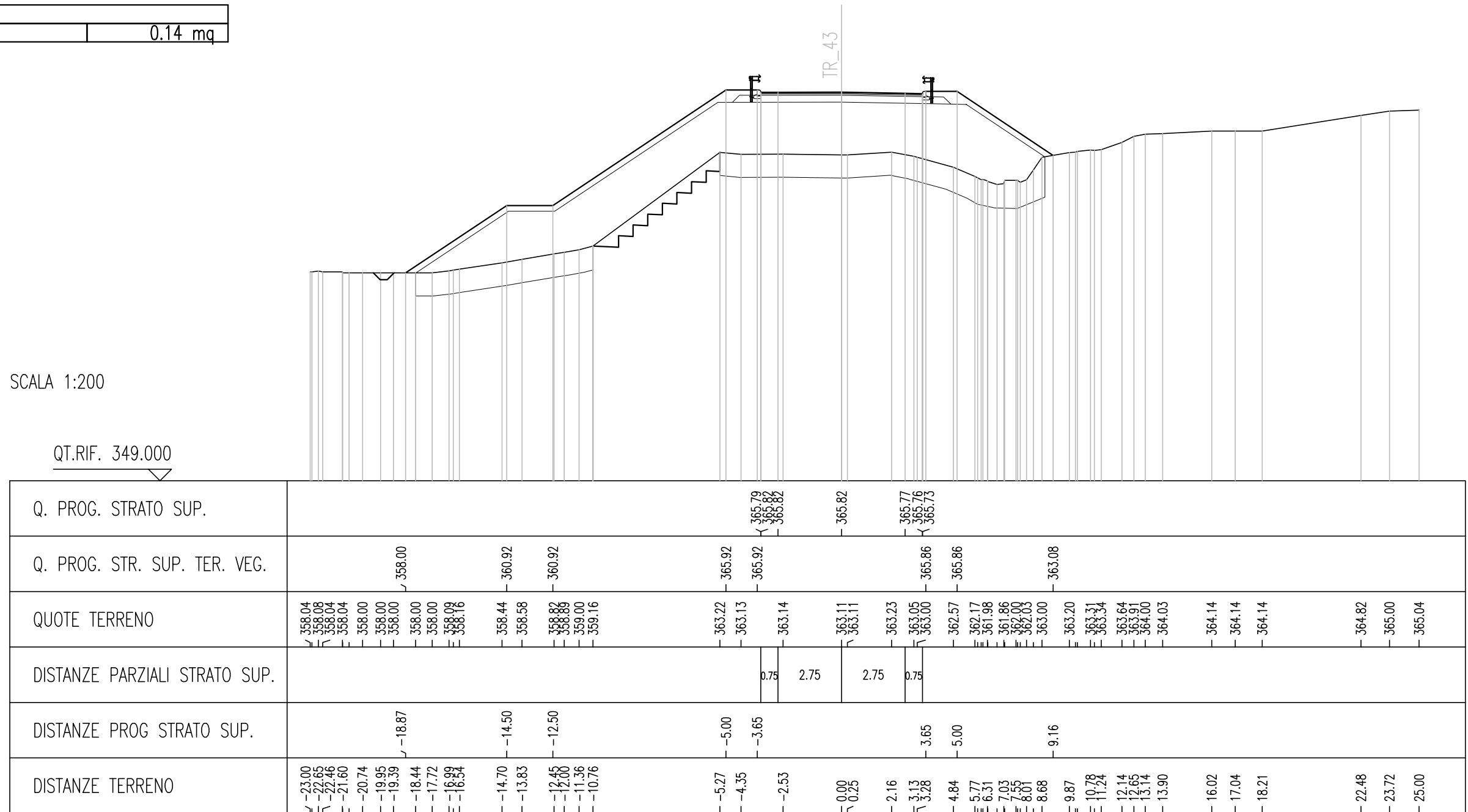

Q. PROG. STRATO SUP.						365.79	365.82	365.82	365.77	365.76	365.73					
Q. PROG. STR. SUP. TER. VEG.				358.00		360.92		360.92		365.92	365.92		365.86	365.86		363.08
QUOTE TERRENO	358.04	358.08	358.04	358.00	358.00	358.00	358.09	358.16		358.44	358.58	358.82	358.89	359.00	359.16	
DISTANZE PARZIALI STRATO SUP.											0.75	2.75	2.75	0.75		
DISTANZE PROG STRATO SUP.				-18.87		-14.50		-12.50		-5.00	-3.65		-3.65	-5.00		-9.16
DISTANZE TERRENO	-23.00	-22.65	-22.46	-21.60	-20.74	-19.95	-19.39	-18.44	-17.72	-16.99	-16.54		-14.70	-13.83	-12.45	-12.00

SCAVI E BONIFICHE	
BONIFICA	23.96 mq
FOSSO (SEZ. OBBL.)	2.19 mq
SCAVO A GRADONI	4.28 m
GRADONI SCAVO	2.76 mq
RILEVATI	
RILEVATO	46.09 mq
TERRENO VEGETALE	6.08 mq
SOVRASTRUTTURA STRADALE	
STRATO DI USURA	0.20 mq
STRATO DI BINDER	0.28 mq
STRATO DI BASE	0.42 mq
STRATO DI FONDAZIONE	2.75 mq
MANUFATTI	
MAGRONE	0.14 mq

SEZIONE N. : 28
 QT. PROGETTO : 364.820
 DIST.PROG. : 0+260.000
 DIST.PREC. : 10.000
 DIST.SUCC. : 10.000

SCALA 1:200

QT.RIF. 348.000

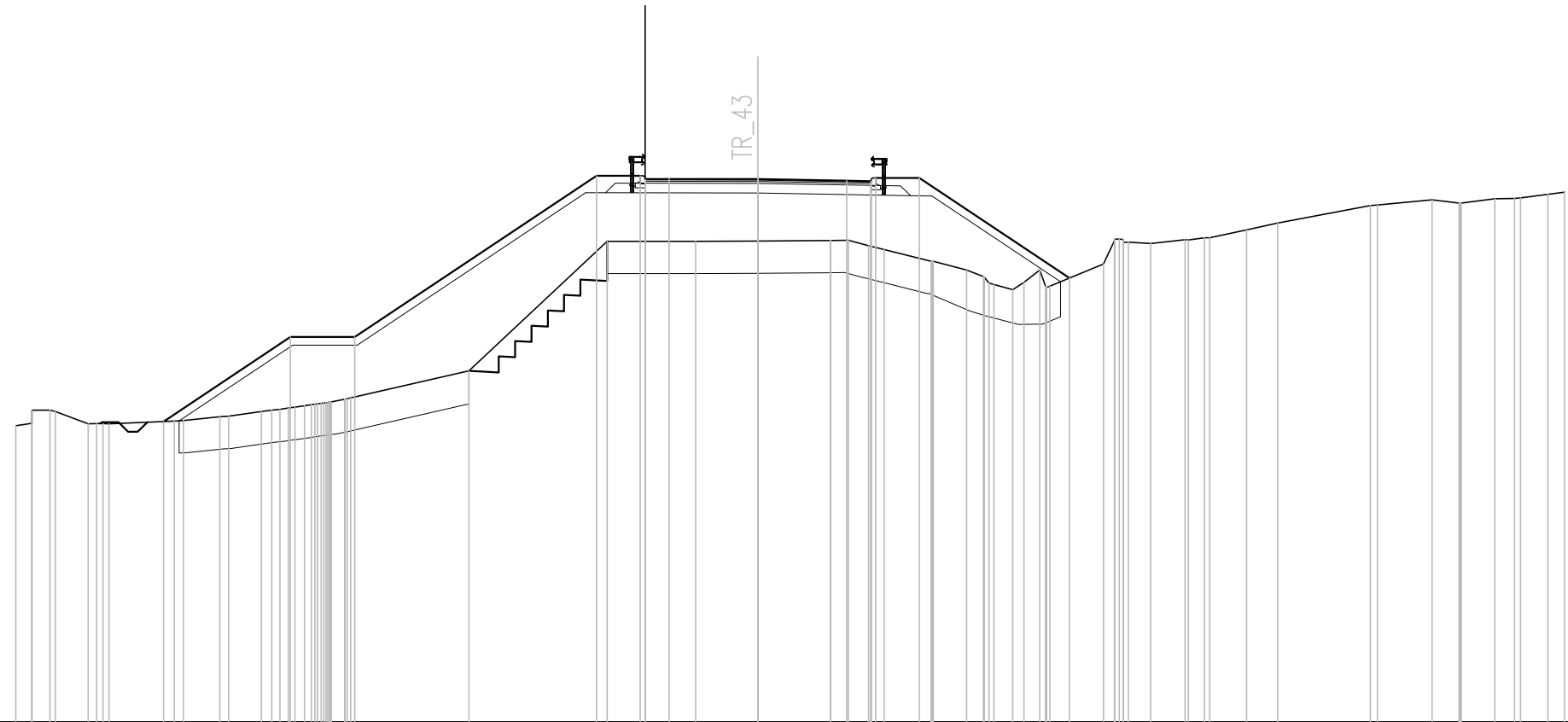

Q. PROG. STRATO SUP.														364.80	364.82	364.82	364.77	364.76	364.73																																	
Q. PROG. STR. SUP. TER. VEG.														364.93	364.93	364.93	364.86	364.86	361.76																																	
QUOTE TERRENO	357.18	357.25	357.66	357.62	357.24	357.24	357.32	357.34	357.46	357.47	357.62	357.99	357.75	357.83	357.89	358.00	358.04	358.88	362.89	362.89	362.90	362.92	362.93	362.76	362.64	362.28	362.28	362.00	361.80	361.40	362.00	361.51	362.19	362.96	362.87	362.82	362.94	363.00	363.00	363.25	363.46	364.00	364.02	364.18	364.07	364.08	364.21	364.21	364.23	364.24	364.35	364.42
DISTANZE PARZIALI STRATO SUP.														0.75	2.75	2.75	0.75																																			
DISTANZE PROG STRATO SUP.														-18.42	-5.00	-3.65	-3.65	5.00	9.65																																	
DISTANZE TERRENO	-23.00	-22.50	-21.95	-21.78	-20.76	-20.30	-20.11	-18.09	-17.80	-16.68	-16.41	-15.39	-14.91	-14.35	-13.84	-13.39	-12.81	-12.62	-8.95	-4.68	-1.93	0.00	-2.25	-2.80	-3.43	-3.91	5.37	5.43	6.47	6.99	7.90	8.73	9.05	10.71	11.20	11.47	12.17	13.24	13.84	14.00	15.15	16.11	18.98	19.20	20.89	21.73	21.80	22.84	23.45	23.63	24.46	25.00

SCAVI E BONIFICHE	
STERRO	4.64 mq
BONIFICA	15.77 mq
FOSSO (SEZ. OBBL.)	0.65 mq
SCAVO A GRADONI	3.91 m
GRADONI SCAVO	2.36 mq

RILEVATI	
RILEVATO	11.99 mq
TERRENO VEGETALE	3.54 mq

SOVRASTRUTTURA STRADALE	
STRATO DI USURA	0.26 mq
STRATO DI BINDER	0.36 mq
STRATO DI BASE	0.54 mq
STRATO DI FONDAZIONE	3.35 mq

MANUFATTI	
MAGRONE	0.14 mq

SEZIONE N. : 33
 QT. PROGETTO : 361.435
 DIST.PROG. : 0+304.488
 DIST.PREC. : 4.488

SCALA 1:200

QT.RIF. 345.000

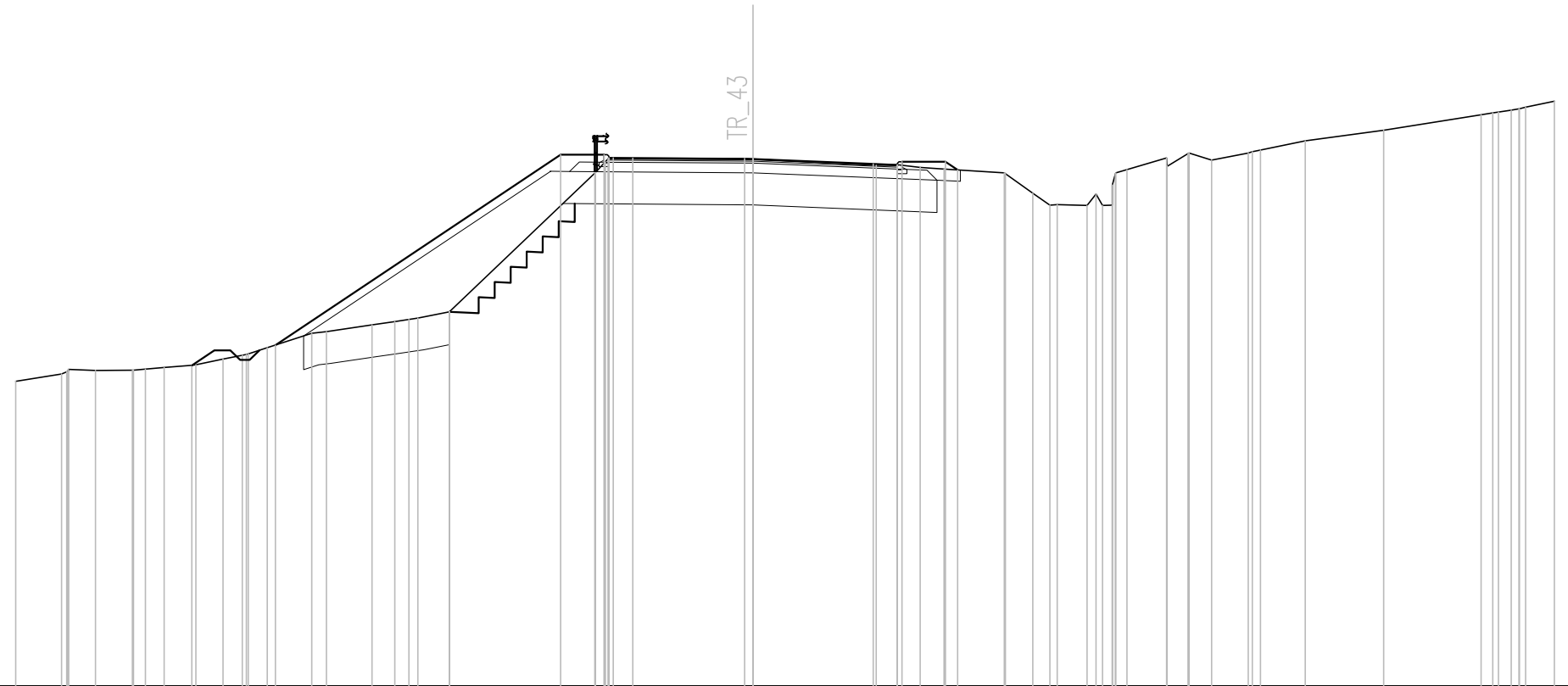

Q. PROG. STRATO SUP.						361.44 361.47 361.46			361.44			361.28 361.25 361.22									
Q. PROG. STR. SUP. TER. VEG.						361.57 361.57						361.35 361.35									
QUOTE TERRENO	354.50	354.73 354.87 354.84	354.84	354.93	355.00 355.02 355.19 355.31 355.55	355.63	356.00 356.05	356.26 356.36 356.43 356.47	356.67	361.00 361.46	361.45 361.44	361.24 361.25 361.18 361.13	361.00 360.98	360.00 360.01 359.98 359.98	361.10	361.47 361.21 361.62 361.40	361.62 361.71	362.00	362.33	362.81 362.90 363.00 363.06 363.24	
DISTANZE PARZIALI STRATO SUP.										0.75 3.75	3.75	0.75									
DISTANZE PROG STRATO SUP.						-14.90				-6.00 -4.65		-4.65 -6.00		-6.38							
DISTANZE TERRENO	-23.00	-21.57 -21.36 -20.51	-19.36	-18.37	-17.51 -17.38 -16.53 -15.93 -15.16	-13.76 -13.31	-11.88 -11.18 -10.73 -10.45	-9.47		-4.93 -4.36	-0.26 0.00	3.84 4.50 5.21 5.96	7.84 7.87	9.26 9.49 10.42 10.90	11.67	12.90 12.91 13.60 14.30	15.44 15.83	17.23	19.67	22.71 23.25 23.90 24.10 25.00	