



**IRON SOLAR S.R.L.**

**PROGETTO PER LA REALIZZAZIONE DI UN IMPIANTO PER LA PRODUZIONE DI ENERGIA MEDIANTE LO SFRUTTAMENTO DEL VENTO NEL TERRITORIO COMUNALE DI SALICE SALENTINO (LE) - VEGLIE (LE)**

**PROGETTO DEFINITIVO**

prima emissione: ottobre 2020

REV.	DATA	DESCRIZIONE:

**PROGETTAZIONE**

**ARCHITETTURA E PAESAGGIO**



via Volga c/o Fiera del Levante Pad.129 - BARI (BA)  
ing. Sebanino GIOTTA - ing. Fabio PACCAPELO  
ing. Francesca SACCAROLA

**VIRUSDESIGN®**  
arch. Vincenzo RUSSO  
via Puglie n.8 - Cerignola (FG)



**IMPIANTI ELETTRICI**

ing. Roberto DI MONTE

**GEOLOGIA**

geol. Pietro PEPE

**ACUSTICA**

ing. Francesco PAPEO

**ARCHEOLOGIA**

Nostoi S.r.l.

**STUDIO PEDO-AGRONOMICO**

dr. for. Sara MASTRANGELO

**ASPETTI FAUNISTICI**

dott. nat. Fabio MASTROPASQUA



**Nostoi S.R.L.**  
Via San Marco, 1511  
30015 CHIOGGIA (VE)  
C.F.P. e Iscra n° 03 653 560 270  
REA VE 327005



**PD.R. ELABORATI DESCRITTIVI**  
**R.3.1 SCHEDA TECNICA AEROGENERATORE**





# SG 6.0-170 Developer Package



# Developer Package SG 6.0-170

## **Application of the Developer Package**

The Developer Package serves the purpose of informing customers about the latest planned product development from Siemens Gamesa Renewable Energy (SGRE). By sharing information about coming developments, SGRE can ensure that customers are provided with necessary information to make decisions.

Furthermore, the Developer Package can assist in guiding prospective customers with the indicated technical footprint of the SG 6.0-170 in cases where financial institutes, governing bodies, or permitting entities require product specific information in their decision processes.

All technical data contained in the Developer Package is subject to change owing to ongoing technical developments. Information contained within the Developer Package may not be treated separately or out of the context of the Developer Package.

The information contained in the Developer Package may not be used as legally binding documentation and cannot be used in contracts between SGRE and any other parties. This Developer Package contains preliminary technical data on SGRE turbines currently under development and can be used in an indicative capacity only.

All technical data is subject to change according to the technical development of the wind turbine.

SGRE and its affiliates reserve the right to change the below specifications without prior notice.

# Developer Package SG 6.0-170

## Table of content

Introduction .....	5
Technical Description .....	6
Technical Specifications .....	8
Nacelle Arrangement .....	9
Nacelle Dimensions .....	10
Elevation Drawing .....	11
Blade Drawing .....	12
Design Climatic Conditions .....	13
Standard Power Curve, Operational mode 1 .....	15
Standard Ct Curve, Operational mode 1 .....	17
Power Curve, Air density, Operational mode 1 .....	19
Ct Curve, Air Density, Operational mode 1 .....	22
Standard Acoustic Emission, Operational Mode 1 .....	24
Noise Reduction System (NRS) operational modes .....	25
Electrical Specifications .....	29
Simplified Single Line Diagram .....	30
Transformer Specifications ECO 30 kV* .....	31
Switchgear Specifications .....	32
Preliminary Foundation Loads .....	34
Tower Dimensions .....	34
Foundation Design .....	34
Preliminary Grid Performance Specification, 50 Hz .....	35
Preliminary Grid Performance Specification, 60 Hz .....	37
Reactive Power Capability, 50 Hz .....	39
Reactive Power Capability, 60 Hz .....	41
SCADA, System Description .....	43
Codes and Standards .....	45
Other Performance Features .....	47

## Introduction

The SG 6.0-170 is a new wind turbine of the next generation Siemens Gamesa Onshore Geared product series, which builds on the Siemens Gamesa design and operational experience in the wind energy market.

With a new 83m blade, a 6.0 MW generator and an extensive tower portfolio including hub heights such as 100m, 115m, 135m and 165m, the SG 6.0-170 aims at becoming a new benchmark in the market for efficiency and profitability.

This Developer Package describes the turbine technical specifications and provides preliminary information for the main components and subsystems.

For further information, please contact your regional SGRE Sales Manager.

---

# Technical Description

## **Rotor-Nacelle**

The rotor is a three-bladed construction, mounted upwind of the tower. The power output is controlled by pitch and torque demand regulation. The rotor speed is variable and is designed to maximize the power output while maintaining loads and noise level.

The nacelle has been designed for safe access to all service points during scheduled service. In addition the nacelle has been designed for safe presence of service technicians in the nacelle during Service Test Runs with the wind turbine in full operation. This allows a high quality service of the wind turbine and provides optimum troubleshooting conditions.

## **Blades**

The SG 6.0-170 blade is made up of fiberglass infusion & carbon pultruded-molded components. The blade structure uses aerodynamic shells containing embedded spar-caps, bonded to two main epoxy-fiberglass-balsa/foam-core shear webs. The SG 6.0-170 blade uses a blade design based on SGRE proprietary airfoils.

## **Rotor Hub**

The rotor hub is cast in nodular cast iron and is fitted to the drive train low speed shaft with a flange connection. The hub is sufficiently large to provide room for service technicians during maintenance of blade roots and pitch bearings from inside the structure.

## **Drive train**

The drive train is a 4-points suspension concept: main shaft with two main bearings and the gearbox with two torque arms assembled to the main frame.

The gearbox is in cantilever position; the gearbox planet carrier is assembled to the main shaft by means of a flange bolted joint and supports the gearbox.

## **Main Shaft**

The low speed main shaft is forged and transfers the torque of the rotor to the gearbox and the bending moments to the bedframe via the main bearings and main bearing housings.

## **Main Bearings**

The low speed shaft of the wind turbine is supported by two spherical roller bearings. The bearings are grease lubricated.

## **Gearbox**

The gearbox is 3 stages high speed type (2 planetary + 1 parallel).

## **Generator**

The generator is a doubly-fed asynchronous three phase generator with a wound rotor, connected to a frequency PWM converter. Generator stator and rotor are both made of stacked magnetic laminations and formed windings. Generator is cooled by air.

## **Mechanical Brake**

The mechanical brake is fitted to the high speed side of the gearbox.

## **Yaw System**

A cast bed frame connects the drive train to the tower. The yaw bearing is an externally geared ring with a friction bearing. A series of electric planetary gear motors drives the yawing.

## **Nacelle Cover**

The weather screen and housing around the machinery in the nacelle is made of fiberglass-reinforced laminated panels.

**Tower**

The wind turbine is as standard mounted on a tapered tubular steel tower. Other tower technologies are available for higher hub heights. The tower has internal ascent and direct access to the yaw system and nacelle. It is equipped with platforms and internal electric lighting.

**Controller**

The wind turbine controller is a microprocessor-based industrial controller. The controller is complete with switchgear and protection devices and is self-diagnosing.

**Converter**

Connected directly with the Rotor, the Frequency Converter is a back to back 4Q conversion system with 2 VSC in a common DC-link. The Frequency Converter allows generator operation at variable speed and voltage, while supplying power at constant frequency and voltage to the MV transformer.

**SCADA**

The wind turbine provides connection to the SGRE SCADA system. This system offers remote control and a variety of status views and useful reports from a standard internet web browser. The status views present information including electrical and mechanical data, operation and fault status, meteorological data and grid station data.

**Turbine Condition Monitoring**

In addition to the SGRE SCADA system, the wind turbine can be equipped with the unique SGRE condition monitoring setup. This system monitors the vibration level of the main components and compares the actual vibration spectra with a set of established reference spectra. Review of results, detailed analysis and reprogramming can all be carried out using a standard web browser.

**Operation Systems**

The wind turbine operates automatically. It is self-starting when the aerodynamic torque reaches a certain value. Below rated wind speed, the wind turbine controller fixes the pitch and torque references for operating in the optimum aerodynamic point (maximum production) taking into account the generator capability. Once rated wind speed is surpassed, the pitch position demand is adjusted to keep a stable power production equal to the nominal value.

High wind derated mode (HWRT) is a default functionality. When active the power production is limited once the wind speed exceeds a threshold value defined by design, until cut-out wind speed is reached and the wind turbine stops producing power.

If the average wind speed exceeds the maximum operational limit, the wind turbine is shut down by pitching of the blades. When the average wind speed drops back below the restart average wind speed, the systems reset automatically.



# Technical Specifications

## Rotor

Type .....	3-bladed, horizontal axis
Position .....	Upwind
Diameter.....	170 m
Swept area .....	22,698 m <sup>2</sup>
Power regulation .....	Pitch & torque regulation with variable speed
Rotor tilt.....	6 degrees

## Blade

Type .....	Self-supporting
Blade length .....	83 m
Max chord .....	4.5 m
Aerodynamic profile .....	Siemens Gamesa proprietary airfoils
Material .....	GRE (Glassfiber Reinforced Epoxy) – CRP (Carbon Reinforced Plastic)
Surface gloss .....	Semi-gloss, < 30 / ISO2813
Surface color .....	Light grey, RAL 7035 or White, RAL 9018

## Aerodynamic Brake

Type .....	Full span pitching
Activation.....	Active, hydraulic

## Load-Supporting Parts

Hub.....	Nodular cast iron
Main shaft.....	Forged steel
Nacelle bed frame .....	Nodular cast iron

## Mechanical Brake

Type .....	Hydraulic disc brake
Position .....	Gearbox rear end

## Nacelle Cover

Type .....	Totally enclosed
Surface gloss .....	Semi-gloss, <30 / ISO2813
Color.....	Light Grey, RAL 7035 or White, RAL 9018

## Generator

Type.....	Asynchronous, DFIG
-----------	--------------------

## Grid Terminals (LV)

Baseline nominal power .	6.0 MW
Voltage .....	690 V
Frequency.....	50 Hz or 60 Hz

## Yaw System

Type.....	Active
Yaw bearing.....	Externally geared
Yaw drive.....	Electric gear motors
Yaw brake.....	Active friction brake

## Controller

Type .....	Siemens Integrated Control System (SICS)
SCADA system .....	SGRE SCADA System

## Tower

Type .....	Tubular steel / Hybrid
Hub height .....	100m to 165 m and site- specific
Corrosion protection .....	
Surface gloss .....	Painted
Color .....	Semi-gloss, <30 / ISO-2813 Light grey, RAL 7035 or White, RAL 9018

## Operational Data

Cut-in wind speed .....	3 m/s
Rated wind speed .....	10.0 m/s (steady wind without turbulence, as defined by IEC61400-1)
Cut-out wind speed .....	25 m/s
Restart wind speed.....	22 m/s

## Weight

Modular approach.....	All modules weight lower than 80 t for transport
-----------------------	---

## Nacelle Arrangement

The design and layout of the nacelle are preliminary and may be subject to changes during the development of the product.

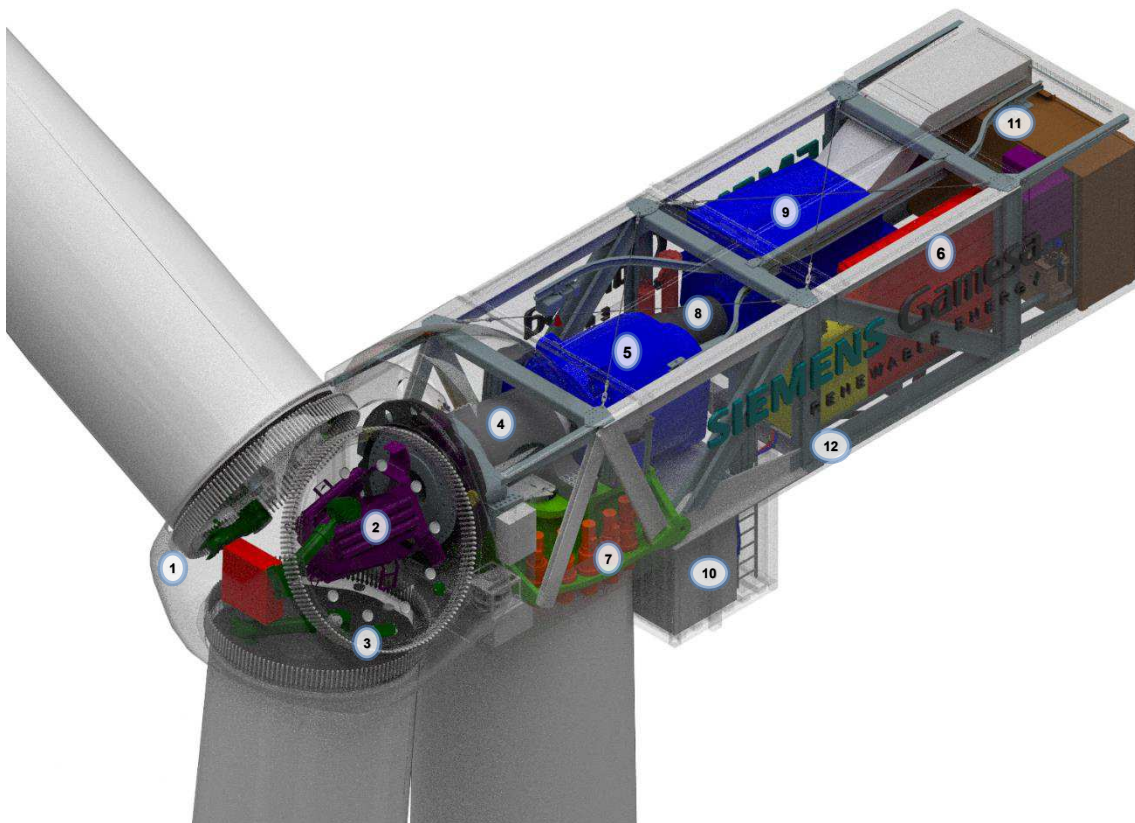

- |                              |                           |
|------------------------------|---------------------------|
| <b>1</b> Hub                 | <b>7</b> Yaw system       |
| <b>2</b> Pitch system        | <b>8</b> High speed shaft |
| <b>3</b> Blade bearings      | <b>9</b> Generator        |
| <b>4</b> Low speed shaft     | <b>10</b> Transformer     |
| <b>5</b> Gearbox             | <b>11</b> Cooling system  |
| <b>6</b> Electrical cabinets | <b>12</b> Rear Structure  |

## Nacelle Dimensions

The design and dimensions of the nacelle are preliminary and may be subject to changes during the development phases of the product.

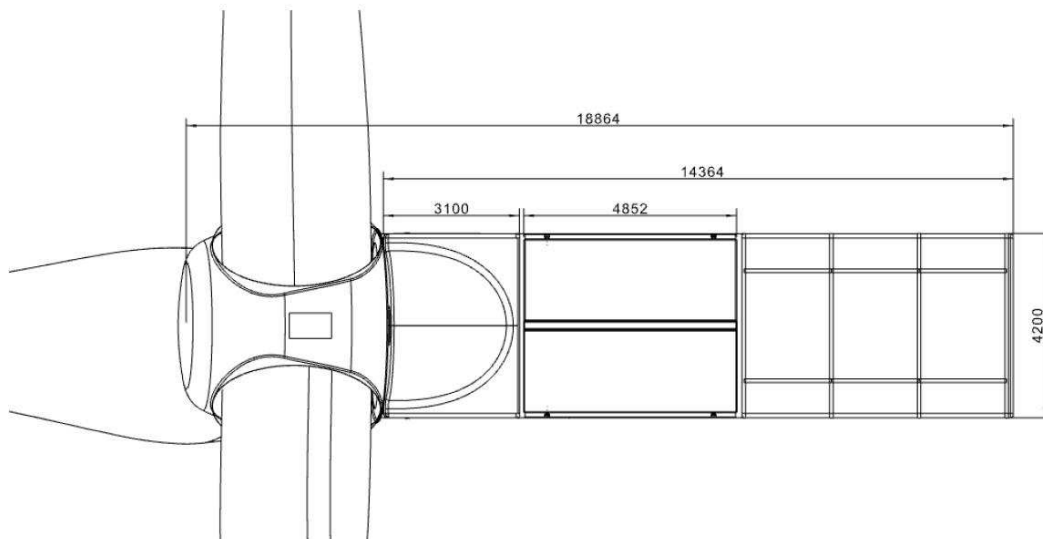
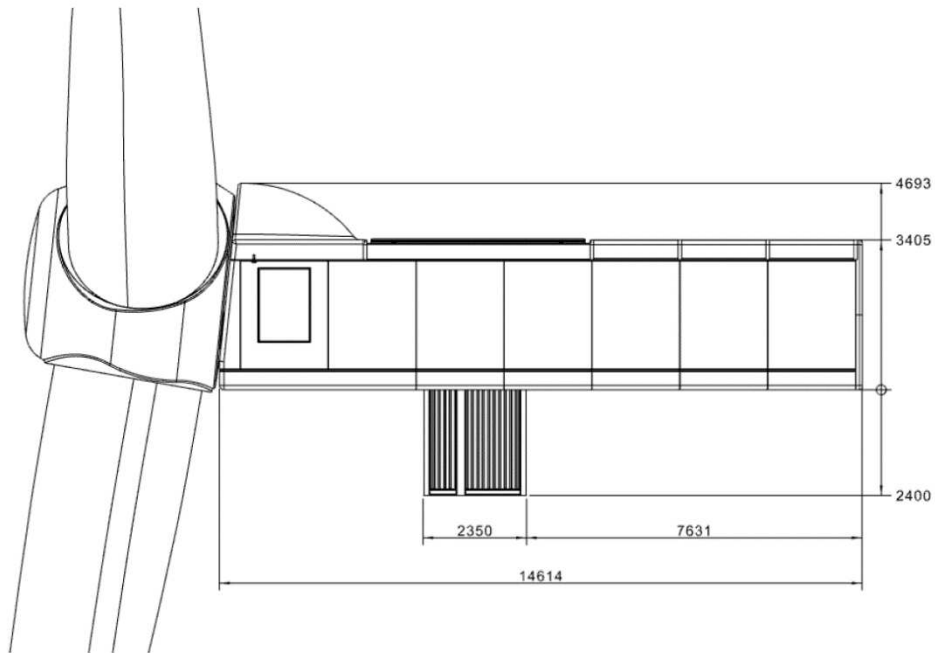

Dimensions in millimeter.

## Elevation Drawing

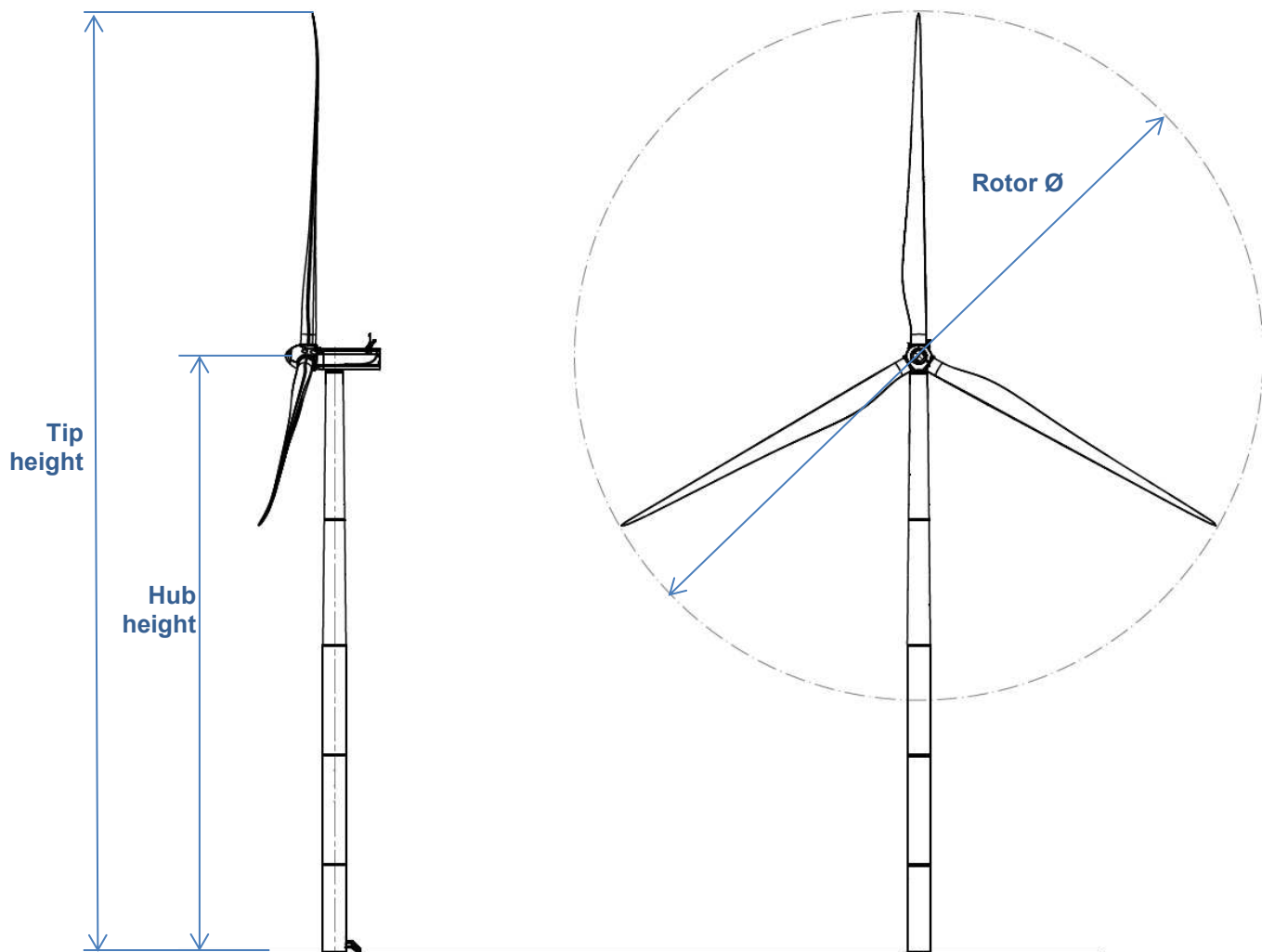

Tip height	185m, 200m, 220m, 250m, and site specific
Hub height	100m, 115m, 135m, 165m, and site specific
Rotor diameter	170m

# Blade Drawing

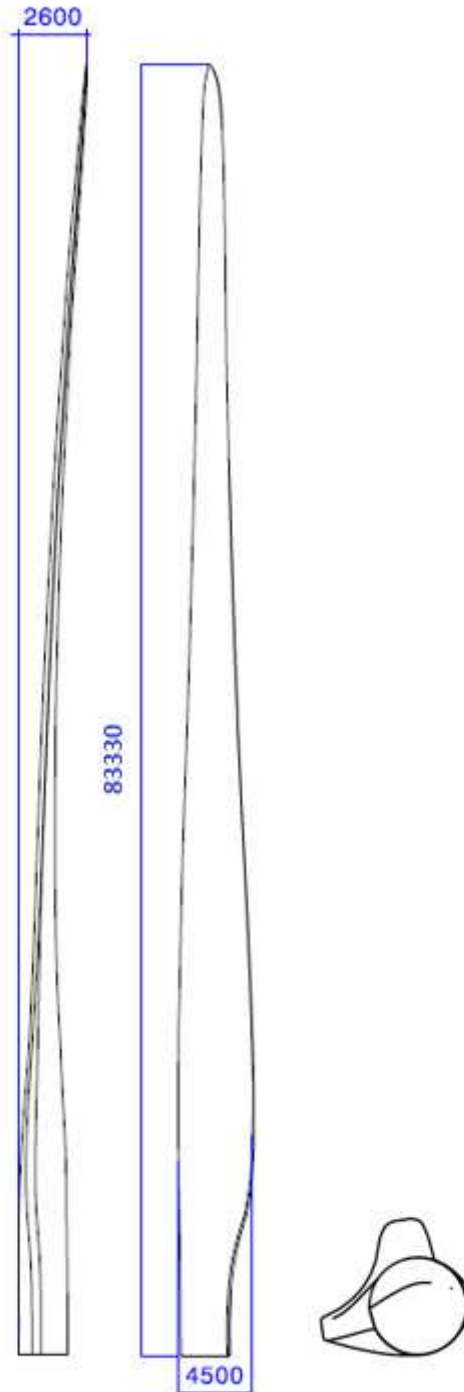

Dimensions in millimeters.

# Design Climatic Conditions

The design climatic conditions are the boundary conditions at which the turbine can be applied without supplementary design review. Applications of the wind turbine in more severe conditions may be possible, depending upon the overall circumstances. A project site-specific review requires that the Employer complete the “Project Climatic Conditions” form.

All references made to standards such as the IEC and ISO are further specified in the document “Codes and Standards”. The design lifetime presented in the below table only applies to the fatigue load analysis performed in accordance with the presented IEC code. The term design lifetime and the use thereof do not constitute any express and/or implied warranty for actual lifetime and/or against failures on the wind turbines. Please see document for “design lifetime of wind turbine components” for more information.

Subject	ID	Issue	Unit	Value	
<b>0. Design lifetime</b>	0.0	Design lifetime definition	-	IEC 61400-1 <sup>1</sup>	
	0.1	Design lifetime	years	20	25
<b>1. Wind, operation</b>	1.1	Wind definitions	-	IEC 61400-1	
	1.2	IEC class	-	IIIA	IIIB
	1.3	Mean air density, $\rho$	kg/m <sup>3</sup>	1.225	1.225
	1.4	Mean wind speed, $V_{ave}$	m/s	7.5	7.5
	1.5	Weibull scale parameter, A	m/s	8.46	8.46
	1.6	Weibull shape parameter, k	-	2	2
	1.7	Wind shear exponent, $\alpha$	-	0.20	0.20
	1.8	Reference turbulence intensity at 15 m/s, $I_{ref}$	-	0.16	0.14
	1.9	Standard deviation of wind direction	Deg	8	8
	1.10	Maximum flow inclination	Deg	8	8
	1.11	Minimum turbine spacing, in rows	D	3	3
	1.12	Minimum turbine spacing, between rows	D	5	5
<b>2. Wind, extreme</b>	2.1	Wind definitions	-	IEC 61400-1	
	2.2	Air density, $\rho$	kg/m <sup>3</sup>	1.225	
	2.3	Reference wind speed average over 10 min at hub height, $V_{ref}$	m/s	37.5	
	2.4	Maximum 3 s gust in hub height, $V_{e50}$	m/s	52.5	
	2.5	Maximum hub height power law index, $\alpha$	-	0.11	
	2.6	Storm turbulence	-	N/A	
<b>3. Temperature</b>	3.1	Temperature definitions	-	IEC 61400-1	
	3.2	Minimum temperature at 2 m, stand-still, $T_{min, s}$	Deg.C	-30	
	3.3	Minimum temperature at 2 m, operation, $T_{min, o}$	Deg.C	-20	
	3.4	Maximum temperature at 2 m, operation, $T_{max, o}$	Deg.C	40 <sup>2</sup>	
	3.5	Maximum temperature at 2 m, stand-still, $T_{max, s}$	Deg.C	50	
<b>4. Corrosion</b>	4.1	Atmospheric-corrosivity category definitions	-	ISO 12944-2	
	4.2	Internal nacelle environment (corrosivity category)	-	C3-H	
	4.3	Exterior environment (corrosivity category)	-	C3-H	
<b>5. Lightning</b>	5.1	Lightning definitions	-	IEC61400-24:2010	
	5.2	Lightning protection level (LPL)	-	LPL 1	
<b>6. Dust</b>	6.1	Dust definitions	-	IEC 60721-3-4:1995	
	6.2	Working environmental conditions	mg/m <sup>3</sup>	Average Dust Concentration (95% time) → 0.05 mg/m3	

<sup>1</sup> All mentioning of IEC 61400-1 refers to IEC 61400-1:2018 Ed4.

<sup>2</sup> Maximum power output may be limited after an extended period of operation with a power output close to nominal power. The limitation depends on air temperature and air density as further described in the High Temperature Ride Through specification.

Subject	ID	Issue	Unit	Value
	6.3	Concentration of particles	mg/m <sup>3</sup>	Peak Dust Concentration (95% time) → 0.5 mg/m <sup>3</sup>
<b>7. Hail</b>	7.1	Maximum hail diameter	mm	20
	7.2	Maximum hail falling speed	m/s	20
<b>8. Ice</b>	8.1	Ice definitions	-	-
	8.2	Ice conditions	Days/yr	7
<b>9. Solar radiation</b>	9.1	Solar radiation definitions	-	IEC 61400-1
	9.2	Solar radiation intensity	W/m <sup>2</sup>	1000
<b>10. Humidity</b>	10.1	Humidity definition	-	IEC 61400-1
	10.2	Relative humidity	%	Up to 95
<b>11. Obstacles</b>	11.1	If the height of obstacles within 500m of any turbine location height exceeds 1/3 of (H – D/2) where H is the hub height and D is the rotor diameter then restrictions may apply. Please contact Siemens Gamesa Renewable Energy for information on the maximum allowable obstacle height with respect to the site and the turbine type.		
<b>12. Precipitation<sup>3</sup></b>	12.1	Annual precipitation	mm/yr	1100

<sup>3</sup> The specified maximum precipitation considers standard liquid Leading Edge Protection. For sites with higher annual precipitation and/or longer lifetime, it is recommended to consider optional reinforced Leading Edge Protection.

# Standard Power Curve, Operational mode 1

Air density 1.225 kg/m<sup>3</sup>

Validity range:

<b>Wind Shear (10min average)</b>	≤ 0.3
<b>Turbulence intensity TI [%] for bin i</b>	$5\% \frac{(0.75v_i + 5.6)}{v_i} < TI_i < 12\% \frac{(0.75v_i + 5.6)}{v_i}$
<b>Terrain</b>	Not complex according to IEC 61400-12-1
<b>Upflow β [°]</b>	-2° ≤ β ≤ +2°
<b>Grid frequency [Hz]</b>	± 0.5 Hz

Other considerations: Clean rotor blades, undisturbed air flow, turbine operated within nominal limits according to the Electrical Specification.

Next table shows the electrical power [kW] as a function of the wind speed [m/s] horizontal referred to the hub height, averaged in ten minutes, for air density = 1.225 kg/m<sup>3</sup>. The power curve does not include losses in the transformer and high voltage cables. The power curve is for the standard version of the turbine.

SG 6.0-170 Rev 0, Mode 1	
Wind Speed [m/s]	Power [kW]
3.0	89
3.5	176
4.0	325
4.5	520
5.0	756
5.5	1039
6.0	1375
6.5	1772
7.0	2232
7.5	2760
8.0	3350
8.5	3976
9.0	4582
9.5	5097
10.0	5476
10.5	5720
11.0	5861
11.5	5934
12.0	5970
12.5	5987
13.0	5994
13.5	5998
14.0	5999
14.5	6000
15.0	6000
15.5	6000
16.0	6000
16.5	6000
17.0	6000

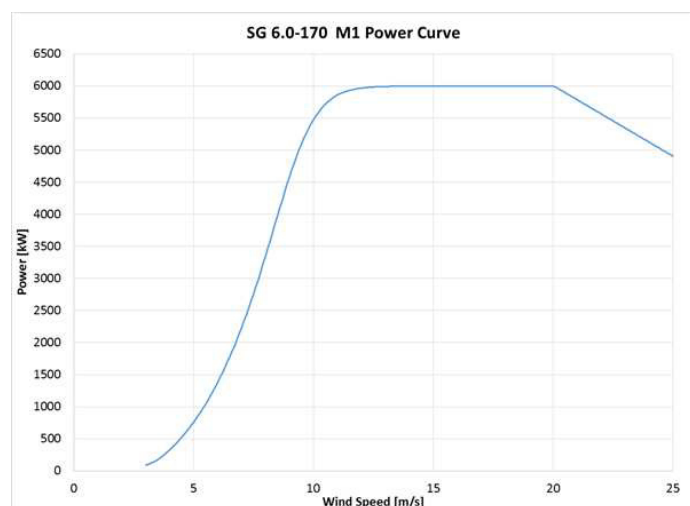



17.5	6000
18.0	6000
18.5	6000
19.0	6000
19.5	6000
20.0	6000
20.5	5898
21.0	5788
21.5	5678
22.0	5568
22.5	5458
23.0	5348
23.5	5237
24.0	5128
24.5	5017
25.0	4907

The annual energy production data for different annual mean wind speeds in hub height are calculated from the above power curve assuming a Weibull wind speed distribution, 100 percent availability, and no reductions due to array losses, grid losses, or other external factors affecting the production.

<b>AEP [MWh]</b>		<b>Annual Average Wind Speed [m/s] at Hub Height</b>										
		<b>5.0</b>	<b>5.5</b>	<b>6.0</b>	<b>6.5</b>	<b>7.0</b>	<b>7.5</b>	<b>8.0</b>	<b>8.5</b>	<b>9.0</b>	<b>9.5</b>	<b>10.0</b>
<b>Weibull K</b>	<b>1.5</b>	12456	14777	16985	19045	20932	22633	24143	25463	26597	27556	28349
	<b>2.0</b>	11420	14213	16981	19646	22160	24492	26628	28557	30276	31783	33079
	<b>2.5</b>	10324	13350	16477	19574	22546	25330	27893	30223	32319	34188	35836

Annual Production [MWh] SG 6.0-170 Rev 0, Mode 1 wind turbine for the standard version, as a function of the annual mean wind speed at hub height, and for different Weibull parameters. Air density 1.225 kg/m<sup>3</sup>

# Standard Ct Curve, Operational mode 1

Air density 1.225 kg/m<sup>3</sup>

Validity range:

<b>Wind Shear (10min average)</b>	≤ 0.3
<b>Turbulence intensity TI [%] for bin i</b>	$5\% \frac{(0.75v_i + 5.6)}{v_i} < TI_i < 12\% \frac{(0.75v_i + 5.6)}{v_i}$
<b>Terrain</b>	Not complex according to IEC 61400-12-1
<b>Upflow β [°]</b>	-2° ≤ β ≤ +2°
<b>Grid frequency [Hz]</b>	± 0.5 Hz

Other considerations: Clean rotor blades, undisturbed air flow, turbine operated within nominal limits according to the Electrical Specification.

The thrust coefficient Ct is used for the calculation of the wind speed deficit in the wake of a wind turbine.

Ct is defined by the following expression:

$$C_t = F / (0.5 \cdot ad \cdot w^2 \cdot A)$$

where

F = Rotor force [N]

ad = Air density [kg/m<sup>3</sup>]

w = Wind speed [m/s]

A = Swept area of rotor [m<sup>2</sup>]

SG 6.0-170 Rev 0, Mode 1	
Wind Speed [m/s]	C <sub>T</sub> [-]
3.0	0.914
3.5	0.859
4.0	0.841
4.5	0.830
5.0	0.821
5.5	0.816
6.0	0.814
6.5	0.813
7.0	0.813
7.5	0.811
8.0	0.803
8.5	0.783
9.0	0.742
9.5	0.679
10.0	0.602
10.5	0.523
11.0	0.450
11.5	0.387
12.0	0.334
12.5	0.291
13.0	0.256
13.5	0.227
14.0	0.202
14.5	0.181

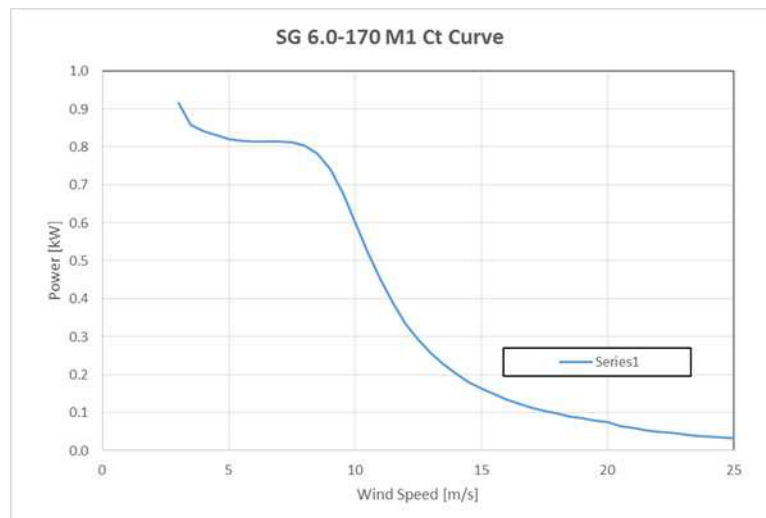

---

15.0	0.163
15.5	0.148
16.0	0.134
16.5	0.123
17.0	0.113
17.5	0.104
18.0	0.097
18.5	0.090
19.0	0.084
19.5	0.079
20.0	0.075
20.5	0.064
21.0	0.059
21.5	0.054
22.0	0.050
22.5	0.046
23.0	0.043
23.5	0.039
24.0	0.037
24.5	0.034
25.0	0.032

# Power Curve, Air density, Operational mode 1

Air density 1.225 kg/m<sup>3</sup>

Validity range:

<b>Wind Shear (10min average)</b>	≤ 0.3
<b>Turbulence intensity TI [%] for bin i</b>	$5\% \frac{(0.75v_i + 5.6)}{v_i} < TI_i < 12\% \frac{(0.75v_i + 5.6)}{v_i}$
<b>Terrain</b>	Not complex according to IEC 61400-12-1
<b>Upflow β [°]</b>	-2° ≤ β ≤ +2°
<b>Grid frequency [Hz]</b>	± 0.5 Hz

Other considerations: Clean rotor blades, undisturbed air flow, turbine operated within nominal limits according to the Electrical Specification.

Next table shows the electrical power as a function of wind speed in hub height, averaged in ten minutes, for air density from 1.06 to 1.27 kg/m<sup>3</sup>. The power curve does not include losses in the transformer and high voltage cables.

<b>P [kW]</b>	<b>Air Density [kg/m<sup>3</sup>]</b>								
	<b>1.225</b>	<b>1.06</b>	<b>1.09</b>	<b>1.12</b>	<b>1.15</b>	<b>1.18</b>	<b>1.21</b>	<b>1.24</b>	<b>1.27</b>
<b>Wind Speed [m/s]</b>									
3.0	89	75	77	80	82	85	87	90	93
3.5	176	143	149	155	161	167	173	179	185
4.0	325	269	279	289	300	310	320	330	341
4.5	520	437	452	467	482	497	512	527	543
5.0	756	642	663	684	704	725	746	767	787
5.5	1039	887	915	942	970	998	1025	1053	1080
6.0	1375	1178	1214	1250	1286	1322	1357	1393	1429
6.5	1772	1521	1567	1612	1658	1703	1749	1794	1840
7.0	2232	1920	1977	2034	2091	2147	2204	2261	2317
7.5	2760	2378	2448	2517	2587	2656	2726	2795	2864
8.0	3350	2893	2976	3060	3143	3226	3309	3391	3473
8.5	3976	3451	3549	3646	3742	3837	3930	4022	4112
9.0	4582	4024	4133	4239	4342	4441	4536	4627	4714
9.5	5097	4570	4680	4784	4881	4973	5057	5135	5207
10.0	5476	5042	5140	5230	5310	5382	5447	5504	5556
10.5	5720	5407	5483	5551	5608	5658	5701	5738	5770
11.0	5861	5659	5712	5756	5793	5824	5850	5871	5889
11.5	5934	5816	5849	5876	5897	5914	5928	5940	5949
12.0	5970	5906	5925	5940	5951	5960	5967	5973	5977
12.5	5987	5954	5964	5972	5977	5982	5985	5988	5990
13.0	5994	5978	5983	5987	5990	5992	5994	5995	5996
13.5	5998	5990	5992	5994	5995	5996	5997	5998	5998
14.0	5999	5995	5996	5997	5998	5998	5999	5999	5999
14.5	6000	5998	5998	5999	5999	5999	5999	6000	6000
15.0	6000	5999	5999	5999	6000	6000	6000	6000	6000
15.5	6000	6000	6000	6000	6000	6000	6000	6000	6000
16.0	6000	6000	6000	6000	6000	6000	6000	6000	6000
16.5	6000	6000	6000	6000	6000	6000	6000	6000	6000
17.0	6000	6000	6000	6000	6000	6000	6000	6000	6000

17.5	6000	6000	6000	6000	6000	6000	6000	6000	6000
18.0	6000	6000	6000	6000	6000	6000	6000	6000	6000
18.5	6000	6000	6000	6000	6000	6000	6000	6000	6000
19.0	6000	6000	6000	6000	6000	6000	6000	6000	6000
19.5	6000	6000	6000	6000	6000	6000	6000	6000	6000
20.0	6000	6000	6000	6000	6000	6000	6000	6000	6000
20.5	5898	5898	5898	5898	5898	5898	5898	5898	5898
21.0	5788	5788	5788	5788	5788	5788	5788	5788	5788
21.5	5678	5678	5678	5678	5678	5678	5678	5678	5678
22.0	5568	5568	5568	5568	5568	5568	5568	5568	5568
22.5	5458	5458	5458	5458	5458	5458	5458	5458	5458
23.0	5348	5348	5348	5348	5348	5348	5348	5348	5348
23.5	5237	5237	5237	5237	5237	5237	5237	5237	5237
24.0	5128	5128	5128	5128	5128	5128	5128	5128	5128
24.5	5017	5017	5017	5017	5017	5017	5017	5017	5017
25.0	4907	4907	4907	4907	4907	4907	4907	4907	4907

The annual energy production data for different annual mean wind speeds in hub height are calculated from the above power curve assuming a Rayleigh wind speed distribution, 100 percent availability, and no reductions due to array losses, grid losses, or other external factors affecting the production.

AEP [MWh] @ k=2		Annual Average Wind Speed [m/s] at Hub Height										
		5.0	5.5	6.0	6.5	7.0	7.5	8.0	8.5	9.0	9.5	10.0
<b>Density [kg/m<sup>3</sup>]</b>	<b>1.06</b>	10099	12714	15354	17940	20415	22742	24896	26862	28630	30193	31551
	<b>1.09</b>	10350	13002	15670	18274	20759	23089	25241	27201	28961	30514	31861
	<b>1.12</b>	10596	13283	15976	18597	21090	23423	25572	27526	29277	30820	32155
	<b>1.15</b>	10837	13556	16273	18908	21409	23742	25889	27836	29578	31111	32434
	<b>1.18</b>	11073	13824	16562	19210	21717	24051	26193	28134	29866	31389	32701
	<b>1.21</b>	11306	14085	16843	19503	22015	24348	26486	28419	30143	31655	32956
	<b>1.225</b>	11420	14213	16981	19646	22160	24492	26628	28557	30276	31783	33079
	<b>1.24</b>	11534	14341	17117	19788	22303	24635	26768	28694	30408	31910	33200
	<b>1.27</b>	11758	14590	17384	20063	22582	24912	27040	28958	30662	32154	33434

Annual Production [MWh] SG 6.0-170 wind turbine for the Mode 1 standard version, as a function of the annual mean wind speed at hub height and for different air densities considering a Rayleigh wind speed distribution.

## Ct Curve, Air Density, Operational mode 1

Air density 1.225 kg/m<sup>3</sup>

Validity range:

<b>Wind Shear (10min average)</b>	≤ 0.3
<b>Turbulence intensity TI [%] for bin i</b>	$5\% \frac{(0.75v_i + 5.6)}{v_i} < TI_i < 12\% \frac{(0.75v_i + 5.6)}{v_i}$
<b>Terrain</b>	Not complex according to IEC 61400-12-1
<b>Upflow β [°]</b>	-2° ≤ β ≤ +2°
<b>Grid frequency [Hz]</b>	± 0.5 Hz

Other considerations: Clean rotor blades, undisturbed air flow, turbine operated within nominal limits according to the Electrical Specification.

The thrust coefficient Ct is used for the calculation of the wind speed deficit in the wake of a wind turbine.

Ct is defined by the following expression:

$$C_t = F / (0.5 * ad * w^2 * A)$$

where

F = Rotor force [N]

ad = Air density [kg/m<sup>3</sup>]

w = Wind speed [m/s]

A = Swept area of rotor [m<sup>2</sup>]

<b>C<sub>T</sub> [-]</b>	<b>Air Density [kg/m3]</b>								
	<b>1.225</b>	<b>1.06</b>	<b>1.09</b>	<b>1.12</b>	<b>1.15</b>	<b>1.18</b>	<b>1.21</b>	<b>1.24</b>	<b>1.27</b>
<b>Wind Speed [m/s]</b>									
3.0	0.914	0.914	0.914	0.914	0.914	0.914	0.914	0.914	0.914
3.5	0.859	0.859	0.859	0.859	0.859	0.859	0.859	0.859	0.859
4.0	0.841	0.841	0.841	0.841	0.841	0.841	0.841	0.841	0.841
4.5	0.830	0.830	0.830	0.830	0.830	0.830	0.830	0.830	0.830
5.0	0.821	0.821	0.821	0.821	0.821	0.821	0.821	0.821	0.821
5.5	0.816	0.816	0.816	0.816	0.816	0.816	0.816	0.816	0.816
6.0	0.814	0.814	0.814	0.814	0.814	0.814	0.814	0.814	0.814
6.5	0.813	0.813	0.813	0.813	0.813	0.813	0.813	0.813	0.813
7.0	0.813	0.813	0.813	0.813	0.813	0.813	0.813	0.813	0.813
7.5	0.811	0.811	0.811	0.811	0.811	0.811	0.811	0.811	0.811
8.0	0.803	0.804	0.804	0.804	0.804	0.804	0.804	0.803	0.803
8.5	0.783	0.787	0.787	0.787	0.786	0.785	0.784	0.782	0.780
9.0	0.742	0.756	0.755	0.753	0.751	0.748	0.744	0.740	0.734
9.5	0.679	0.709	0.706	0.701	0.696	0.690	0.683	0.675	0.666
10.0	0.602	0.649	0.643	0.635	0.627	0.618	0.608	0.597	0.586
10.5	0.523	0.581	0.572	0.562	0.551	0.540	0.529	0.517	0.505
11.0	0.450	0.512	0.501	0.490	0.479	0.467	0.456	0.444	0.433
11.5	0.387	0.447	0.436	0.425	0.414	0.403	0.392	0.382	0.372
12.0	0.334	0.390	0.379	0.368	0.358	0.348	0.339	0.330	0.322
12.5	0.291	0.340	0.330	0.321	0.312	0.304	0.295	0.288	0.280
13.0	0.256	0.299	0.290	0.282	0.274	0.266	0.259	0.253	0.246

13.5	0.227	0.264	0.256	0.249	0.242	0.236	0.229	0.224	0.218
14.0	0.202	0.234	0.228	0.221	0.215	0.210	0.204	0.199	0.195
14.5	0.181	0.210	0.204	0.198	0.193	0.188	0.183	0.179	0.174
15.0	0.163	0.188	0.183	0.178	0.174	0.169	0.165	0.161	0.157
15.5	0.148	0.170	0.166	0.161	0.157	0.153	0.149	0.146	0.142
16.0	0.134	0.155	0.150	0.146	0.143	0.139	0.136	0.133	0.130
16.5	0.123	0.141	0.137	0.134	0.130	0.127	0.124	0.121	0.119
17.0	0.113	0.130	0.126	0.123	0.120	0.117	0.114	0.111	0.109
17.5	0.104	0.119	0.116	0.113	0.111	0.108	0.105	0.103	0.101
18.0	0.097	0.111	0.108	0.105	0.103	0.100	0.098	0.096	0.093
18.5	0.090	0.103	0.101	0.098	0.096	0.093	0.091	0.089	0.087
19.0	0.084	0.097	0.094	0.092	0.090	0.087	0.085	0.084	0.082
19.5	0.079	0.091	0.088	0.086	0.084	0.082	0.080	0.079	0.077
20.0	0.075	0.086	0.083	0.081	0.079	0.077	0.076	0.074	0.072
20.5	0.064	0.073	0.071	0.069	0.067	0.066	0.064	0.063	0.062
21.0	0.059	0.067	0.065	0.063	0.062	0.061	0.059	0.058	0.057
21.5	0.054	0.061	0.060	0.058	0.057	0.056	0.054	0.053	0.052
22.0	0.050	0.056	0.055	0.054	0.052	0.051	0.050	0.049	0.048
22.5	0.046	0.052	0.051	0.050	0.048	0.047	0.046	0.045	0.045
23.0	0.043	0.048	0.047	0.046	0.045	0.044	0.043	0.042	0.041
23.5	0.039	0.044	0.043	0.042	0.042	0.041	0.040	0.039	0.038
24.0	0.037	0.041	0.040	0.039	0.038	0.038	0.037	0.036	0.036
24.5	0.034	0.038	0.037	0.037	0.036	0.035	0.034	0.034	0.033
25.0	0.032	0.036	0.035	0.034	0.033	0.033	0.032	0.031	0.031



# Standard Acoustic Emission, Operational Mode 1

## Sound Power Level ( $L_{WA}$ ):

Sound Power Level warranted according to IEC 61400-11 ed. 3.1 is given in table below.

A measurement uncertainty margin corresponding to 1.5 dB must be considered when demonstrating compliance with given Sound Power Level.

SG 6.0-170	
Wind Speed [m/s]	LW [dB(A)]
3.0	92.0
3.5	92.0
4.0	92.0
4.5	92.2
5.0	94.5
5.5	96.5
6.0	98.4
6.5	100.2
7.0	101.8
7.5	103.3
8.0	104.7
8.5	105.5
9.0	105.5
9.5	105.5
10.0	105.5
10.5	105.5
11.0	105.5
11.5	105.5
12.0	105.5
12.5	105.5
13.0	105.5
13.5	105.5
14.0	105.5
14.5	105.5
15.0	105.5
15.5	105.5
16.0	105.5
16.5	105.5
17.0	105.5
17.5	105.5
18.0	105.5
18.5	105.5
19.0	105.5
19.5	105.5

20.0	105.5
20.5	105.5
21.0	105.5
21.5	105.5
22.0	105.5
22.5	105.5
23.0	105.5
23.5	105.5
24.0	105.5
24.5	105.5
25.0	105.5

Sound Power Level included in the present document correspond to the wind turbine configuration equipped with noise reduction add-ons attached to the blade.

## Noise Reduction System (NRS) operational modes

The Noise Reduction System NRS is an optional module available with the basic SCADA configuration and it therefore requires the presence of a SGRE SCADA system to work.

The purpose of this system is to limit the noise emitted by any of the functioning turbines and thereby comply with local regulations regarding noise emissions. This allows wind farms to be located close to urban areas, limiting the environmental impact that they imply.

Noise control is achieved through reducing the active power and rotational speed of the wind turbine. This reduction is dependent on the wind speed:

The task of the Noise Reduction System is to control the noise settings of each turbine to the most appropriate level at all times, in order to keep the noise emissions within the limits allowed.

In order to do this, the SCADA control has to consider the wind speed of each turbine, its direction, and a configured schedule/calendar.

There are 7 low noise modes available, besides the full operation one. Noise levels corresponding to each mode are the following:

<b>Mode:</b>	<b>M2</b>	<b>M3</b>	<b>M4</b>	<b>M5</b>	<b>M6</b>	<b>M7</b>
<b>Sound Power Level [dB(A)]</b>	104.5	103.0	102.0	101.0	100.0	99.0

Sound Power Level included in the present document correspond to the wind turbine configuration equipped with noise reduction add-ons attached to the blade.

Depending on the type of tower selected, some of the low noise modes defined above may not be compatible. Low noise modes compatibility vs tower designs will be analyzed upon request.

Next table presents the power production as a function of the horizontal wind speed measured at hub height for different noise reduction mode settings.

P [kW]	Low Noise Operation Mode					
Wind Speed [m/s]	M2	M3	M4	M5	M6	M7
3.0	89	88	89	89	89	89
3.5	176	175	176	176	176	176
4.0	325	325	325	325	325	325
4.5	520	519	520	520	520	520
5.0	756	756	756	756	756	756
5.5	1038	1038	1038	1038	1038	1038
6.0	1373	1373	1373	1373	1372	1369
6.5	1768	1768	1768	1764	1754	1740
7.0	2227	2222	2218	2202	2167	2125
7.5	2749	2722	2708	2660	2582	2494
8.0	3316	3238	3207	3109	2976	2817
8.5	3893	3733	3677	3519	3328	3073
9.0	4430	4171	4087	3871	3629	3260
9.5	4884	4528	4417	4160	3876	3384
10.0	5231	4795	4665	4385	4073	3463
10.5	5470	4979	4840	4553	4224	3514
11.0	5621	5096	4955	4673	4335	3547
11.5	5708	5164	5028	4753	4410	3568
12.0	5754	5202	5070	4804	4458	3582
12.5	5778	5221	5094	4834	4487	3590
13.0	5790	5231	5107	4851	4503	3595
13.5	5795	5236	5114	4861	4511	3597
14.0	5798	5238	5117	4865	4516	3599
14.5	5799	5239	5119	4868	4518	3599
15.0	5800	5240	5119	4869	4519	3600
15.5	5800	5240	5120	4869	4520	3600
16.0	5800	5240	5120	4870	4520	3600
16.5	5800	5240	5120	4870	4520	3600
17.0	5800	5240	5120	4870	4520	3600
17.5	5800	5240	5120	4870	4520	3600
18.0	5800	5240	5120	4870	4520	3600
18.5	5800	5240	5120	4870	4520	3600
19.0	5800	5240	5120	4870	4520	3600
19.5	5800	5240	5120	4870	4520	3600
20.0	5800	5240	5120	4870	4520	3600
20.5	5721	5208	5105	4870	4520	3600
21.0	5637	5172	5081	4870	4520	3600
21.5	5553	5137	5057	4870	4520	3600
22.0	5469	5101	5033	4870	4520	3600
22.5	5385	5066	5009	4870	4520	3600
23.0	5301	5030	4985	4870	4520	3600
23.5	5217	4995	4961	4870	4520	3600
24.0	5134	4959	4936	4870	4520	3600
24.5	5051	4924	4912	4870	4520	3600
25.0	4967	4888	4888	4870	4520	3600

Next table presents the Ct as a function of the horizontal wind speed measured at hub height for different noise reduction mode settings. The calculated Ct curve data are valid for clean rotor blades, substantially horizontal, undisturbed air flow, normal turbulence intensity and normal wind shear.

Ct [ - ] Wind Speed [m/s]	Low Noise Operation Mode					
	M2	M3	M4	M5	M6	M7
3.0	0.953	0.963	0.953	0.953	0.953	0.953
3.5	0.880	0.886	0.880	0.880	0.880	0.880
4.0	0.847	0.850	0.847	0.847	0.847	0.847
4.5	0.828	0.829	0.828	0.828	0.828	0.828
5.0	0.824	0.824	0.824	0.824	0.824	0.824
5.5	0.828	0.828	0.828	0.828	0.827	0.825
6.0	0.833	0.833	0.832	0.830	0.824	0.815
6.5	0.836	0.833	0.830	0.822	0.803	0.784
7.0	0.835	0.822	0.815	0.795	0.762	0.732
7.5	0.825	0.795	0.782	0.750	0.706	0.666
8.0	0.799	0.750	0.734	0.691	0.641	0.593
8.5	0.754	0.691	0.674	0.626	0.575	0.519
9.0	0.694	0.625	0.606	0.559	0.510	0.448
9.5	0.625	0.556	0.538	0.494	0.451	0.385
10.0	0.553	0.489	0.472	0.434	0.396	0.330
10.5	0.484	0.427	0.412	0.381	0.348	0.285
11.0	0.420	0.371	0.359	0.334	0.306	0.247
11.5	0.365	0.323	0.313	0.293	0.270	0.215
12.0	0.318	0.283	0.274	0.258	0.238	0.189
12.5	0.278	0.248	0.241	0.228	0.210	0.167
13.0	0.245	0.219	0.213	0.202	0.186	0.148
13.5	0.217	0.195	0.190	0.180	0.166	0.132
14.0	0.194	0.174	0.170	0.161	0.149	0.119
14.5	0.174	0.156	0.152	0.145	0.134	0.107
15.0	0.157	0.141	0.138	0.131	0.121	0.097
15.5	0.142	0.128	0.125	0.118	0.110	0.088
16.0	0.129	0.116	0.114	0.108	0.100	0.081
16.5	0.118	0.106	0.104	0.099	0.092	0.074
17.0	0.109	0.098	0.096	0.091	0.084	0.068
17.5	0.100	0.091	0.088	0.084	0.078	0.063
18.0	0.093	0.084	0.082	0.078	0.073	0.059
18.5	0.087	0.078	0.077	0.073	0.068	0.055
19.0	0.081	0.073	0.072	0.068	0.064	0.052
19.5	0.076	0.069	0.068	0.064	0.060	0.049
20.0	0.072	0.065	0.064	0.061	0.056	0.046
20.5	0.062	0.056	0.055	0.053	0.049	0.040
21.0	0.057	0.052	0.052	0.049	0.046	0.038
21.5	0.053	0.049	0.048	0.046	0.043	0.036
22.0	0.049	0.046	0.045	0.044	0.041	0.034
22.5	0.045	0.043	0.042	0.041	0.038	0.032
23.0	0.042	0.040	0.040	0.039	0.036	0.030
23.5	0.039	0.038	0.037	0.037	0.034	0.029
24.0	0.037	0.035	0.035	0.035	0.033	0.027
24.5	0.034	0.033	0.033	0.033	0.031	0.026
25.0	0.032	0.032	0.032	0.031	0.029	0.025

The table below contains the noise levels as a function of the horizontal wind speed measured at hub height for different noise reduction mode settings.

Noise values included in the present document correspond to the wind turbine configuration equipped with noise reduction add-ons attached to the blade.

Sound Power [dB(A)]	Low Noise Operation Mode					
Wind Speed [m/s]	M2	M3	M4	M5	M6	M7
3.0	92.0	92.0	92.0	92.0	92.0	92.0
4.0	92.0	92.0	92.0	92.0	92.0	92.0
5.0	94.5	94.5	94.5	94.5	94.5	94.5
6.0	98.4	98.4	98.4	98.4	98.4	98.4
7.0	101.8	101.8	101.8	101.0	100.0	99.0
8.0	104.5	103.0	102.0	101.0	100.0	99.0
9.0	104.5	103.0	102.0	101.0	100.0	99.0
10.0	104.5	103.0	102.0	101.0	100.0	99.0
11.0	104.5	103.0	102.0	101.0	100.0	99.0
12.0	104.5	103.0	102.0	101.0	100.0	99.0
13.0	104.5	103.0	102.0	101.0	100.0	99.0
Up to cut-out	104.5	103.0	102.0	101.0	100.0	99.0

Sound Power Level included in the present document correspond to the wind turbine configuration equipped with noise reduction add-ons attached to the blade.

# Electrical Specifications

## Nominal output and grid conditions

Nominal power .....	6000 kW
Nominal voltage .....	690 V
Power factor correction .....	Frequency converter control
Power factor range.....	0.9 capacitive to 0.9 inductive at nominal balanced voltage

## Generator

Type .....	DFIG Asynchronous
Maximum power.....	6150 kW

Nominal speed .....	1120 rpm-6p (50Hz) 1344 rpm-6p (60Hz)
---------------------	--

## Generator Protection

Insulation class .....	Stator F/H Rotor F/H
Winding temperatures .....	6 Pt 100 sensors
Bearing temperatures.....	3 Pt 100
Slip Rings	1 Pt 100
Grounding brush.....	On side no coupling

## Generator Cooling

Cooling system .....	Air cooling
Internal ventilation .....	Air
Control parameter .....	Winding, Air, Bearings temperatures

## Frequency Converter

Operation .....	4Q B2B Partial Load
Switching .....	PWM
Switching freq., grid side...	2.5 kHz
Cooling.....	Liquid/Air

## Main Circuit Protection

Short circuit protection .....	Circuit breaker
Surge arrester .....	varistors

## Peak Power Levels

10 min average .....	Limited to nominal
----------------------	--------------------

## Grid Requirements

Nominal grid frequency.....	50 or 60 Hz
Minimum voltage.....	85 % of nominal
Maximum voltage.....	113 % of nominal
Minimum frequency .....	94 % of nominal
Maximum frequency .....	106 % of nominal
Maximum voltage imbalance (negative sequence of component voltage).....	≤5 %
Max short circuit level at controller's grid	
Terminals (690 V) .....	67 kA

## Power Consumption from Grid (approximately)

At stand-by, No yawing.....	10 kW
At stand-by, yawing .....	41 kW

## Controller back-up

UPS Controller system .....	Online UPS, Li battery
Back-up time.....	1 min
Back-up time Scada.....	24 h

## Transformer Requirements

Transformer impedance requirement.....	8.0 % - 10.5%
Secondary voltage .....	690 V
Vector group .....	Dyn 11 or Dyn 1 (star point earthed)

## Earthing Requirements

Earthing system .....	Acc. to IEC62305-3 ED 1.0:2006
Foundation reinforcement..	Must be connected to earth electrodes
Foundation terminals .....	Acc. to SGRE Standard
HV connection .....	HV cable shield shall be connected to earthing system

**All data are subject to tolerances in accordance with IEC.**

# Simplified Single Line Diagram

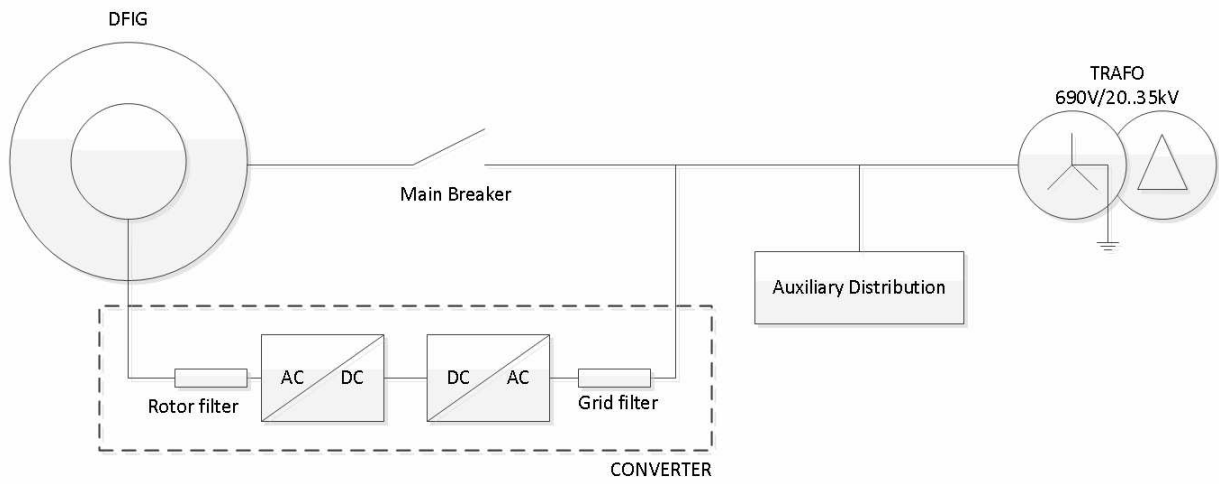

# Transformer Specifications ECO 30 kV\*

## Transformer

Type .....	Liquid type
Nominal power .....	7200 kVA at nominal voltage +/-10 %
Nominal voltage .....	33/0.69 kV
Frequency .....	50 Hz
Transformer impedance .....	10.6%
Loss (P <sub>0</sub> /P <sub>n120°C</sub> ).....	3.5/113.5 kW
Vector group .....	Dyn11
Offload tap changer .....	+/- 2 x 2.5%
Standard .....	IEC 60076 ECO Design Directive

## Transformer Cooling

Cooling type.....	KFWF
Liquid inside transformer...	K-class liquid
Cooling liquid at heat exchanger .....	Glysantin

## Transformer Monitoring

Top oil temperature.....	PT100 sensor
Oil level monitoring sensor...	Digital input
Overpressure relay.....	Digital input

## Transformer Earthing

Star point .....	The star point of the transformer must be connected to earth
------------------	--

**All data are subject to tolerances in accordance with IEC.**

**\*Example for an ECO 34.5 kV transformer. For other Medium Voltage transformers, consult with SGRE**



---

# Switchgear Specifications

The switchgear will be chosen as factory-assembled, type-tested, and maintenance-free medium-voltage switchgear with single-busbar system. The device will be metal-enclosed, metal-clad, gas-isolated, and conforms to the stipulations of IEC 62271-200.

The switchgear vessel of the gas-insulated switchgear is classified according to IEC as a “sealed pressure system”. It is gas-tight for life. The switchgear vessel accommodates the busbar system and switching device (such as vacuum circuit breaker, three-position switch disconnecting and earthing).

The vessel is filled with sulphur hexafluoride (SF<sub>6</sub>) at the factory. This gas is non-toxic, chemically inert, and features a high dielectric strength. Gas work on site is not required, and even in operation it is not necessary to check the gas condition or refill, the vessel is designed for being gas tight for life.

To monitor the gas density, every switchgear vessel is equipped with a ready-for-service indicator at the operating front. This is a mechanical red/green indicator, self-monitoring and independent of temperature and variations of the ambient air pressure.

MV cables connected to the grid cable- and circuit-breaker feeders are connected via cast-resin bushings leading into the switchgear vessel. The bushings are designed as outside-cone system type “C” M16 bolted 630 A connections according to EN 50181. The compartment is accessible from the front. A mechanical interlock ensures that the cable compartment cover can only be removed when the three-position switch is in the earthed position.

The circuit-breaker operates based on vacuum switching technology. The vacuum interrupter unit is installed in the switchgear vessel together with the three-position switch and is thus protected from environmental influences. The operating mechanism of the circuit-breaker is located outside the vessel. Both, the interrupters and the operating mechanisms, are maintenance-free.

Padlock facilities are provided to lock the switchgear from operation in disconnect open and close position, earth switch open and close position, and circuit breaker open position, to prevent improper operation of the equipment.

Capacitive Voltage detection systems are installed both in the grid cable and the circuit breaker feeders. Pluggable indicators can be plugged at the switchgear front to show the voltage status.

The switchgear is equipped with an over-current protection relay with the functions over current, short circuit and earth fault protection. The relay ensures that the transformer is disconnected if a fault occurs in the transformer or the medium voltage installation in the wind turbine. The relay is adjustable to obtain selectivity between low voltage main breaker and the circuit breaker in the substation.

The protection relay is a self-powered overcurrent protection relay that does not require external auxiliary voltage supply. It imports its power supply from current transformers, that are already mounted on the bushings inside the circuit breaker panel and is therefore ideal for wind turbine applications.

Trip signals from the transformer auxiliary protection and wind turbine controller can also disconnect the switchgear.

The switchgear consists of two or more feeders<sup>4</sup>; one circuit breaker feeder for the wind turbine transformer also with earthing switch and one or more grid cable feeders<sup>5</sup> with load break switch and earthing switch.

The switchgear can be operated local at the front or by use of portable remote control (circuit breaker only) connected to a control box at the wind turbine entrance level.

---

<sup>4</sup> Up to four feeders.

<sup>5</sup> SGRE to be contacted for possible feeder configurations of circuit breaker and grid feeder combinations.

The switchgear is located below the tower structure. The main transformer, LV switchgear and converters are located on the nacelle level above the tower.

Grid cables, from substation and/or between the turbines, must be installed at the bushings in the grid cable feeder cubicles of the switchgear. These bushings are the interface/grid connection point of the turbine. It is possible to connect grid cables in parallel by installing the cables on top of each other. Depending on the cable termination kit, up to three grid cable sets can be connected in this cable compartment.

The transformer cables are installed at the bottom of the circuit breaker feeder. The cable compartment is accessible from the front. A mechanical interlock ensures that the cable compartment cover can only be removed when the three-position switch is in the earthed position.

Optionally, the switchgear can be delivered with surge arresters installed in between the switchgear and wind turbine transformer on the outgoing bushings of the circuit breaker feeder.

## Technical Data for Switchgear

### Switchgear

Make	TBD
Type	TBD
Rated voltage	10,5-36 kV
Operating voltage	10,5-35 kV (Um 40,5kV)
Rated current	630 A
Short time withstand current	20 kA/1s
Peak withstand current	50 kA
Power frequency withstand voltage	70 kV
Lightning withstand voltage	170 kV
Insulating medium	SF <sub>6</sub>
Switching medium	Vacuum
Consist of	2/3/4 panels
Grid cable feeder	Load break switch
Circuit breaker feeder	Circuit breaker
Degree of protection, vessel	IP65
Internal arc classification IAC:	A FLR 20 kA 1s
Pressure relief	Upwards
Standard	IEC 62271
Temperature range	-25°C to +45°C

### Grid cable feeder

Rated current, Cubicle	630 A
Rated current, load breaker	630 A
Short time withstand current	20 kA/1s
Short circuit making current	50 kA/1s
Three position switch	Closed, open, earthed
Switch mechanism	Spring operated
Control	Local
Voltage detection system	Capacitive

### Circuit breaker feeder

Rated current, Cubicle	630 A
Rated current circuit breaker	630 A
Short time withstand current	20 kA/1s
Short circuit making current	50 kA/1s
Short circuit breaking current	20 kA/1s
Three position switch	Closed, open, earthed
Switch mechanism	Spring operated
Tripping mechanism	Stored energy

### Control

Coil for external trip	24 V DC
Voltage detection system	Capacitive

### Protection

Over-current relay	Self-powered
Functions	50/51 50N/51N
Power supply	Integrated CT supply

### Interface- MV Cables

Grid cable feeder	630 A bushings type C M16 Max 3 feeder cables
Cable entry	From bottom
Cable clamp size (cable outer diameter) <sup>6</sup>	26 - 38mm 36 - 52mm 50 - 75mm
Circuit breaker feeder	630 A bushings type C M16
Cable entry	From bottom
<b>Interface to turbine control</b>	
Breaker status	1 NO contact
SF6 supervision	1 NO contact
External trip	24 V DC

**Siemens Gamesa and its affiliates reserve the right to change the above specifications without prior notice. All data are subject to tolerances in accordance with IEC.**

<sup>6</sup> Cable clamps are not part of switchgear delivery.

## Preliminary Foundation Loads

Detailed information about foundation loads will be available upon request.

## Tower Dimensions

SG 6.0-170 is offered with a an extensive tower portfolio ranging from 100m-165m. All the towers are designed in compliance with local logistics requirements.

Information about catalogue tower heights will be available upon request.

## Foundation Design

Detailed information about foundation loads will be available upon request

# Preliminary Grid Performance Specification, 50 Hz

## General

This document describes the grid performance of the SG 6.0-170, 50 Hz wind turbine. Siemens Gamesa Renewable Energy (SGRE) will provide wind turbine technical data for the developer to use in the design of the wind power plant and the evaluation of requirements compliance. The developer will be responsible for the evaluation and ensuring that the requirements are met for the wind power plant.

The capabilities described in this document are based on the assumption that the electrical network is designed to be compatible with operation of the wind turbine. SGRE will provide a document with guidance to perform an assessment of the network's compatibility.

## Fault Ride Through (FRT) Capability

The wind turbine is capable of operating when voltage transient events occur on the interconnecting transmission system above and below the standard voltage lower limits and time slot according to **Figure 1**. Lower voltage limits for SG 6.0-170, 50 Hz wind turbine in the range of 0-70 seconds. The nominal voltage is 690 V (i.e. 1 p.u.).

This performance assumes that the installed amount of wind turbines is in the right proportion to the strength of the grid, which means that the short circuit ratio ( $S_k/S_n$ ) and the X/R ratio of the grid at the wind turbine transformer terminals must be adequate.

Evaluation of the wind turbine's fault ride through capability in a specific system must be based on simulation studies using the specific network model and a dynamic wind turbine model provided by SGRE in PSS/E. This model is a reduced order model, suitable for balanced simulations with time steps between 4-10 ms.

The standard voltage limits for the SG 6.0-170, 50 Hz wind turbine are presented in **Figure 1**. Lower voltage limits for SG 6.0-170, 50 Hz wind turbine in the range of 0-70 seconds. The nominal voltage is 690 V (i.e. 1 p.u.).

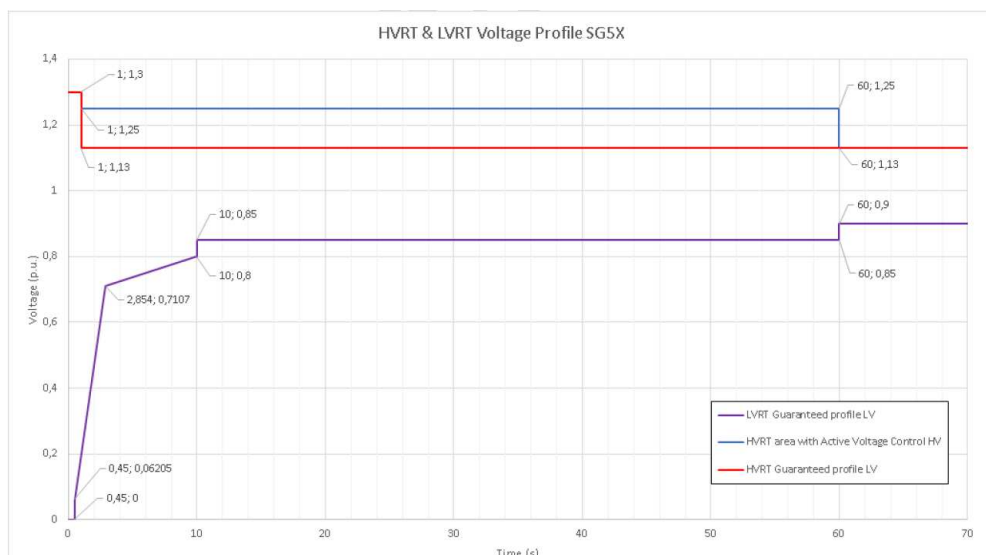

**Figure 1.** Lower voltage limits for SG 6.0-170, 50 Hz wind turbine in the range of 0-70 seconds. The nominal voltage is 690 V (i.e. 1 p.u.).

**Power Factor (Reactive Power) Capability**

The wind turbine is able to operate in a wide power factor range at the low voltage side of the wind turbine transformer. See the Reactive Power capability chapter for more details. The control mode for the wind turbine is with reactive power set-points.

**Supervisory Control and Data Acquisition (SCADA) Capability**

The SGRE SCADA system has the capability to transmit and receive instructions from the transmission system provider for system reliability purposes depending on the configuration of the SCADA system. The project specific SCADA requirements must be specified in detail for design purposes.

**Frequency Capability**

The wind turbine is able to operate in the frequency range between 47 Hz and 53 Hz.

**Voltage Capability**

The voltage operation range for the wind turbine is between 85% and 113% of nominal voltage at the low voltage side of the wind turbine transformer. The voltage can be up to 130% for 60ms. The wind turbine's target voltage shall stay between 95% and 105% in order to support the best possible performance by staying within the operation limits.

**Flicker and Harmonics**

Flicker and Harmonics values will be provided in the power quality measurement report extract in accordance with IEC 61400-21 Edition 2.

**Reactive Power -Voltage Control**

The power plant controller can operate in four different modes:

- Q Control – In this mode reactive power is controlled at the point of interconnection, according to a reactive power reference
- V Control – Voltage is directly controlled at the point of interconnection, according to a voltage reference
- V-Q static – Voltage is controlled at the point of interconnection, by means of a pre-defined voltage – reactive power characteristic
- Power factor (cosphi) control – Power factor is controlled at the point of interconnection, according to a power factor reference

The SCADA system receives feedback/measured values from the Point Of Interconnection depending on the control mode it is operating. The wind power plant controller then compares the measured values against the target levels and calculates the reactive power reference. Finally, reactive power references are distributed to each individual wind turbine. The wind turbine's controller responds to the latest reference from the SCADA system and will generate the required reactive power accordingly from the wind turbine.

**Frequency Control**

The frequency control is managed by the SCADA system together with the wind turbine controller. The wind power plant frequency control is carried out by the SCADA system which distributes active power set-points to each individual wind turbine, to the controllers. The wind turbine controller responds to the latest reference from the SCADA system and will maintain this active power locally.

**All data are subject to tolerances in accordance with IEC.**

# Preliminary Grid Performance Specification, 60 Hz

## General

This document describes the grid performance of the SG 6.0-170, 60 Hz wind turbine. Siemens Gamesa Renewable Energy (SGRE) will provide wind turbine technical data for the developer to use in the design of the wind power plant and the evaluation of requirements compliance. The developer will be responsible for the evaluation and ensuring that the requirements are met for the wind power plant.

The capabilities described in this document are based on the assumption that the electrical network is designed to be compatible with operation of the wind turbine. SGRE will provide a document with guidance to perform an assessment of the network's compatibility.

## Fault Ride Through (FRT) Capability

The wind turbine is capable of operating when voltage transient events occur on the interconnecting transmission system above and below the standard voltage lower limits and time slot according to **Figure 2**. Lower voltage limits for SG 6.0-170, 60 Hz wind turbine in the range of 0-70 seconds. The nominal voltage is 690 V (i.e. 1 p.u.).

This performance assumes that the installed amount of wind turbines is in the right proportion to the strength of the grid, which means that the short circuit ratio ( $S_k/S_n$ ) and the X/R ratio of the grid at the wind turbine transformer terminals must be adequate.

Evaluation of the wind turbine's fault ride through capability in a specific system must be based on simulation studies using the specific network model and a dynamic wind turbine model provided by SGRE in PSS/E. This model is a reduced order model, suitable for balanced simulations with time steps between 4-10 ms.

The standard voltage limits for the SG 6.0-170, 60 Hz wind turbine are presented in **Figure 2**. Lower voltage limits for SG 6.0-170, 60 Hz wind turbine in the range of 0-70 seconds. The nominal voltage is 690 V (i.e. 1 p.u.).

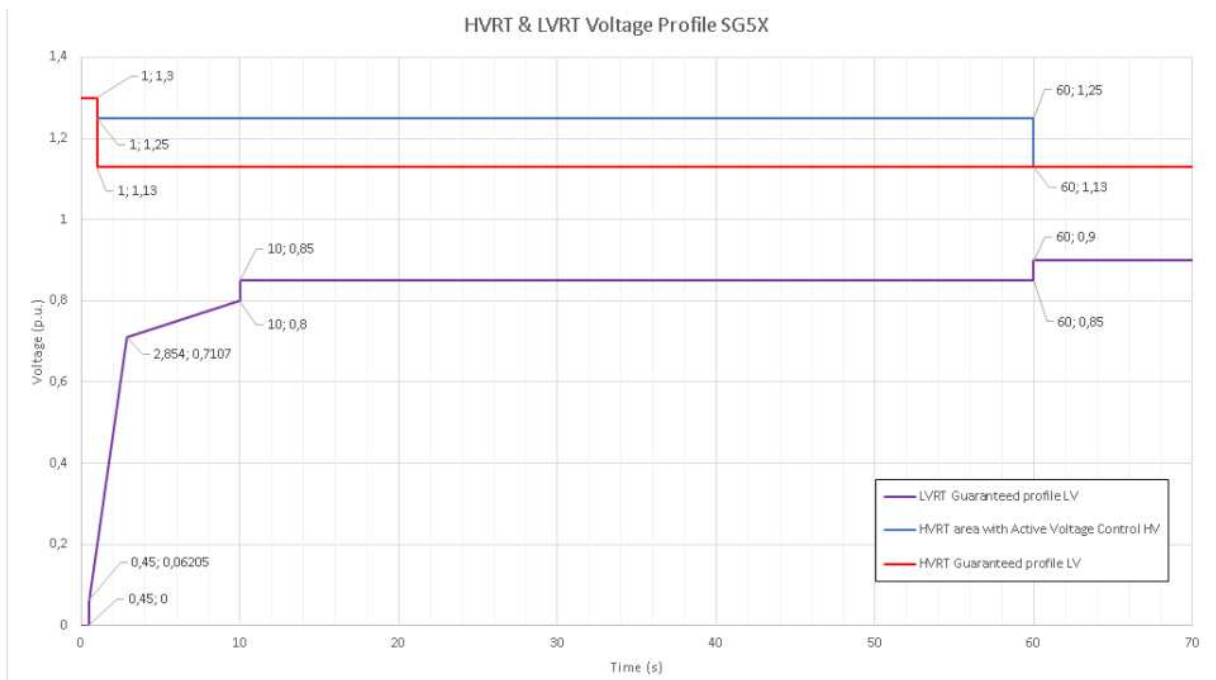

**Figure 2.** Lower voltage limits for SG 6.0-170, 60 Hz wind turbine in the range of 0-70 seconds. The nominal voltage is 690 V (i.e. 1 p.u.).

**Power Factor (Reactive Power) Capability**

The wind turbine is able to operate in a wide power factor range at the low voltage side of the wind turbine transformer. See the Reactive Power capability chapter for more details. The control mode for the wind turbine is with reactive power set-points

**Supervisory Control and Data Acquisition (SCADA) Capability**

The SGRE SCADA system has the capability to transmit and receive instructions from the transmission system provider for system reliability purposes depending on the configuration of the SCADA system. The project specific SCADA requirements must be specified in detail for design purposes.

**Frequency Capability**

The wind turbine is able to operate in the frequency range between 56.4 Hz and 63.6 Hz.

**Voltage Capability**

The voltage operation range for the wind turbine is between 85% and 113% of nominal voltage at the low voltage side of the wind turbine transformer. The voltage can be up to 130% for 60ms. The wind turbine's target voltage shall stay between 95% and 105% in order to support the best possible performance by staying within the operation limits

**Flicker and Harmonics**

Flicker and Harmonics values will be provided in the power quality measurement report extract in accordance with IEC 61400-21 Edition 2.

**Reactive Power -Voltage Control**

The power plant controller can operate in four different modes:

- Q Control – In this mode reactive power is controlled at the point of interconnection, according to a reactive power reference
- V Control – Voltage is directly controlled at the point of interconnection, according to a voltage reference
- V-Q static – Voltage is controlled at the point of interconnection, by means of a pre-defined voltage – reactive power characteristic
- Power factor (cosphi) control – Power factor is controlled at the point of interconnection, according to a power factor reference

The SCADA system receives feedback/measured values from the Point Of Interconnection depending on the control mode it is operating. The wind power plant controller then compares the measured values against the target levels and calculates the reactive power reference. Finally, reactive power references are distributed to each individual wind turbine. The wind turbine's controller responds to the latest reference from the SCADA system and will generate the required reactive power accordingly from the wind turbine.

**Frequency Control**

The frequency control is managed by the SCADA system together with the wind turbine controller. The wind power plant frequency control is carried out by the SCADA system which distributes active power set-points to each individual wind turbine, to the controllers. The wind turbine controller responds to the latest reference from the SCADA system and will maintain this active power locally.

**All data are subject to tolerances in accordance with IEC.**

# Reactive Power Capability, 50 Hz

## General

This document describes the reactive power capability of SG 6.0-170, 50 Hz wind turbines during active power production. SG 6.0-170 wind turbines are equipped with a B2B Partial load frequency converter which allows the wind turbine to operate in a wide power factor range.

The maximum amount of Reactive Power to be generated or consumed depends on a wide range of parameters, some of them not possible to consider in a general way as they are fully dependent on the site and grid conditions.

Between others, the Reactive Power Capability at a given Operating Conditions depends on existing Active Power, internal temperature of WTG components, external ambient temperature, Grid conditions (voltage level, frequency level, etc) and impact, thermally, in high inertial systems. So, the required operation time in worse conditions is also a parameter to be considered.

Online maximum capabilities estimation is executed by the Reactive Power Controller algorithm, in order to provide the possibility of maximizing the Capabilities in favorable grid and site conditions.

## Reactive Power Capability Curves

The estimated maximum reactive power capability for the wind turbine at the LV side of the wind turbine transformer will be presented in the following Figures.

Figure 1 and 2 show the reactive power capability depending on the generated Active Power at LV terminals, at various voltages between 0.85 p.u. and 1.12 p.u. at the LV terminals. The reference external temperature is set to maximum. Capabilities when reducing ambient temperatures increase.

Between voltages of +112% and +113%, as well as between 85% and 86%, Reactive Power Controller enters in Voltage Saturation Mode and will not allow an amount of Reactive Power generation or consumption that would cause a trip due to over or under voltage protections, caused by the own operation of the turbine. These levels are possible to be set.

Figure 3 includes reactive power capability at no wind operating conditions (QwP0).

The SCADA can send voltage references to the wind turbine in the range of 0.92 p.u. to 1.08 p.u. The wind power plant should be designed to maintain the wind turbine voltage references between 0.95 p.u. and 1.05 p.u. during steady state operation.

The tables and figures assume that the phase voltages are balanced, and that the grid operational frequency and component values are nominal. Unbalanced voltages will decrease the reactive power capability. Component tolerances were not considered in determining curve parameters. Instead, the curves and data are subject to an overall tolerance of  $\pm 5\%$  of the rated power.

The reactive power capability presented in this document is the net capability and accounts for the contribution from the wind turbine auxiliary system, the reactors and the existing filters.

The reactive power capability described is valid while operating the wind turbine within the limits specified in the Design Climatic Conditions.



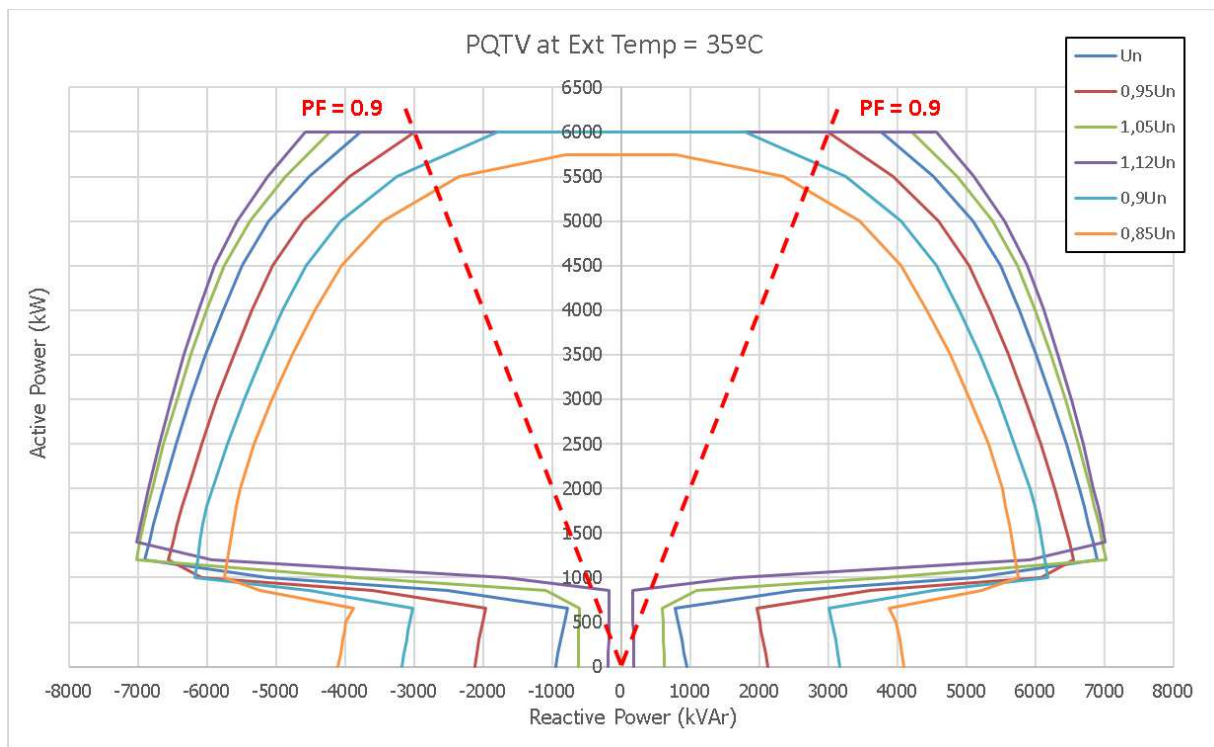

**Figure 1:** Reactive power capability curves, 50 Hz Wind Turbine, at LV terminals. 35°C External Ambient Temperature

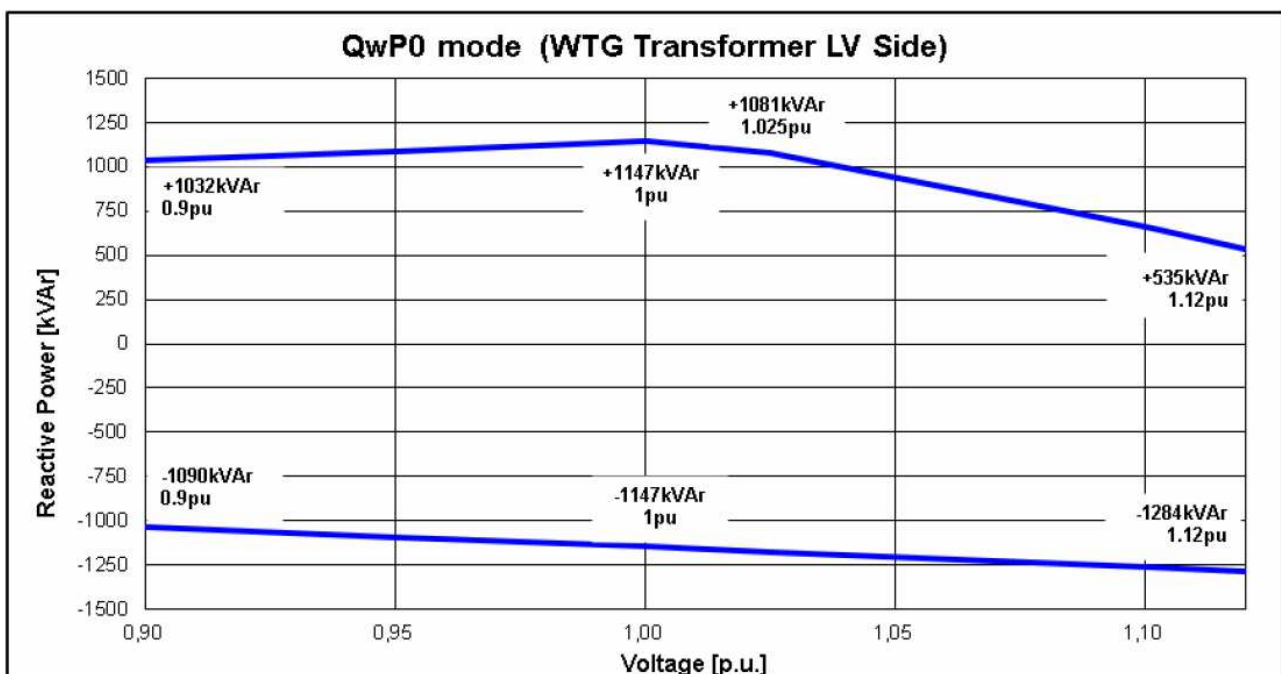

**Figure 3:** Reactive power capability at no wind (QwP0)

All data are subject to tolerances in accordance with IEC.

# Reactive Power Capability, 60 Hz

## General

This document describes the reactive power capability of SG 6.0-170, 60 Hz wind turbines during active power production. SG 6.0-170 wind turbines are equipped with a B2B Partial load frequency converter which allows the wind turbine to operate in a wide power factor range.

The maximum amount of Reactive Power to be generated or consumed depends on a wide range of parameters, some of them not possible to consider in a general way as they are fully dependent on the site and grid conditions.

Between others, the Reactive Power Capability at a given Operating Conditions depends on existing Active Power, internal temperature of WTG components, external ambient temperature, Grid conditions (voltage level, frequency level, etc) and impact, thermally, in high inertial systems. So, the required operation time in worse conditions is also a parameter to be considered.

Online maximum capabilities estimation is executed by the Reactive Power Controller algorithm, in order to provide the possibility of maximizing the Capabilities in favorable grid and site conditions.

## Reactive Power Capability Curves

The estimated maximum reactive power capability for the wind turbine at the LV side of the wind turbine transformer will be presented in the following Figures.

Figure 1 and 2 show the reactive power capability depending on the generated Active Power at LV terminals, at various voltages between 0.85 p.u. and 1.12 p.u. at the LV terminals. The reference external temperature is set to maximum. Capabilities when reducing ambient temperatures increase.

Between voltages of +112% and +113%, as well as between 85% and 86%, Reactive Power Controller enters in Voltage Saturation Mode and will not allow an amount of Reactive Power generation or consumption that would cause a trip due to over or under voltage protections, caused by the own operation of the turbine. These levels are possible to be set.

Figure 3 includes reactive power capability at no wind operating conditions (QwP0).

The SCADA can send voltage references to the wind turbine in the range of 0.92 p.u. to 1.08 p.u. The wind power plant should be designed to maintain the wind turbine voltage references between 0.95 p.u. and 1.05 p.u. during steady state operation.

The tables and figures assume that the phase voltages are balanced, and that the grid operational frequency and component values are nominal. Unbalanced voltages will decrease the reactive power capability. Component tolerances were not considered in determining curve parameters. Instead, the curves and data are subject to an overall tolerance of  $\pm 5\%$  of the rated power.

The reactive power capability presented in this document is the net capability and accounts for the contribution from the wind turbine auxiliary system, the reactors and the existing filters.

The reactive power capability described is valid while operating the wind turbine within the limits specified in the Design Climatic Conditions.

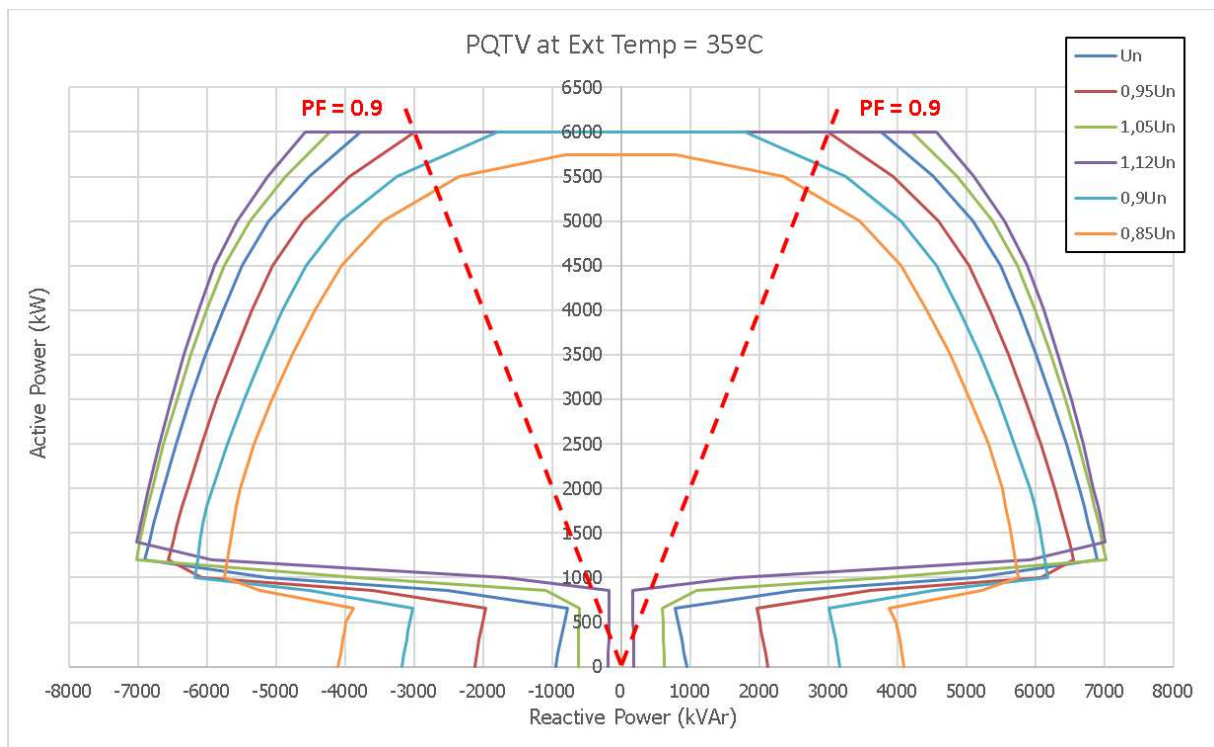

**Figure 1:** Reactive power capability curves, 60 Hz Wind Turbine, at LV terminals. 35°C External Ambient Temperature

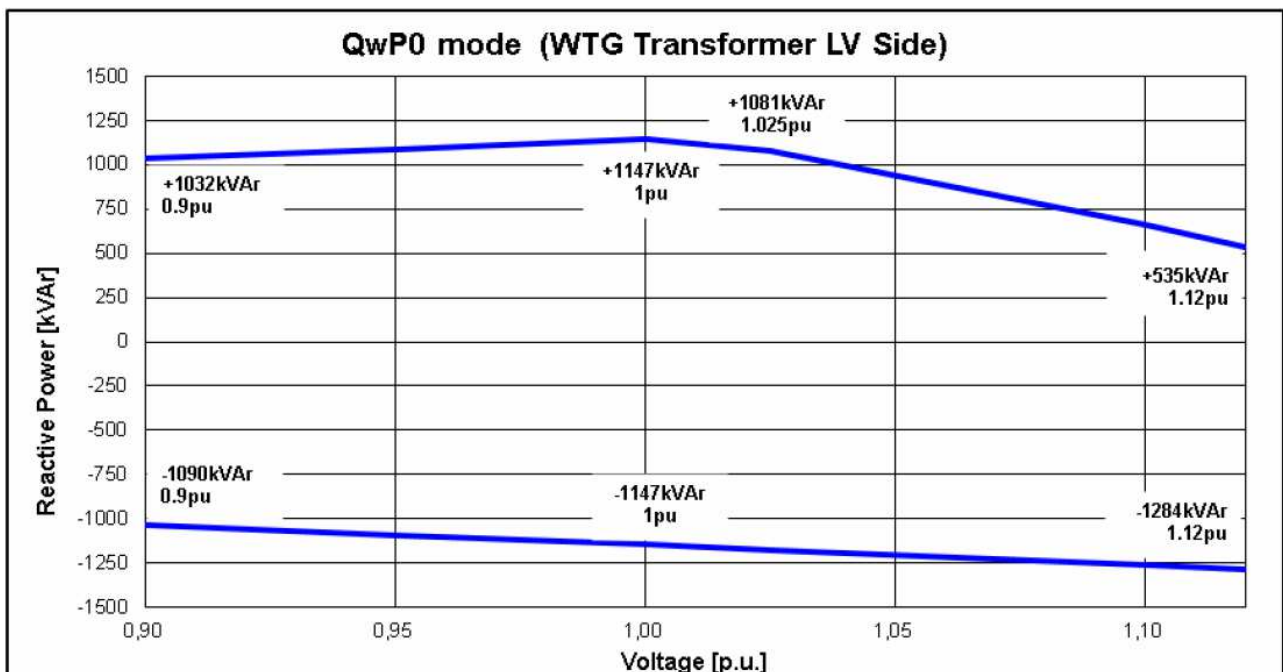

**Figure 3:** Reactive power capability at no wind (QwP0)

# SCADA, System Description

## Introduction

This is a general description of the SGRE SCADA System.

The SGRE SCADA system is a system for supervision, data acquisition, control, and reporting for wind farm performance.

## Main features

The SCADA system has the following main features:

- On-line supervision and control accessible via Internet.
- Data acquisition and storage of data in a historical database.
- Local storage of data at wind turbines if communication is interrupted and transferred to historical database when possible.
- System access from anywhere using a standard web browser. No special client software or licenses are required.
- Users are assigned individual user names and passwords, and the administrator can assign a user level to each user name for added security.
- Email function can be configured for fast alarm response for both turbine and substation alarms.
- Interface to park pilot functions for enhanced control of the wind farm and for remote regulation, e.g. MW / Voltage / Frequency / Ramp rate.
- Power curve plots and efficiency calculations with pressure and temperature correction (pressure and temperature correction available only if SGRE MET system supplied).
- Condition monitoring integrated with the turbine controller using designated server.
- Ethernet-based system with compatible interfaces (OPC XML / IEC 60870-5-104 / Modbus TCP).
- Virus Protection Solution.
- Back-up & restore.

## Wind turbine hardware

Components within the wind turbine are monitored and controlled by the individual local wind turbine controller (STC). The STC can operate the turbine independently of the SCADA system, and turbine operation can continue autonomously in case of, e.g. damage to communication cables.

A turbine interface computer (STIC) placed at the tower base handles the interface between the STC and the central SCADA server. Data recorded in the turbine is stored here temporary. In the event that communication to the central server is temporarily interrupted data is kept in the STIC and transferred to the SCADA server when possible. The STIC is considered part of the wind turbine.

## Communication network in wind farm

The communication network in the wind farm must be established with optical fibers. The optimum network design is typically a function of the wind farm layout. Once the layout is selected, SGRE will define the minimum requirements for the network design.

The supply, installation, and termination of the communication network are carried out by the Employer.

## SCADA server panel

The central SCADA server panel supplied by SGRE is normally placed at the wind farm substation or control building.

The server panel comprises amongst others:

- The server is configured with standard disk redundancy (RAID) to ensure continuous operation in case of disk failure. Network equipment. This includes all necessary switches and media converters.

- UPS back up to ensure safe shut down of servers in case of power outage.

For large sites or as option a virtualized SCADA solution can be supplied.

On the SCADA server the data is presented online as a web-service and simultaneously stored in an SQL database. From this SQL database numerous reports can be generated.

Employer “client” connection to the SCADA system establishing via the internet through a point to point TCP/IP VPN-connection.

### **Grid measuring station**

The SCADA system includes a GMS located in one / more GMS panels or in the SCADA server panel. Normally the GMS is placed at the wind farm substation or control building.

The heart of the GMS is a PQ meter and the HPPP. The HPPP/GMS can be scaled to almost any arrangement of the grid connection. The HPPP/GMS requires voltage and current signals from VT's and CT's fitted at the wind farm PCC to enable its control functions.

The GMS interfaces to the SGRE SCADA servers and turbines are via a LAN network.

The HPPP can on request be supplied in a high availability (HA) setup with a redundant server cluster configuration.

Note: In small SGRE SCADA systems (typically <10 turbines) and if the small SGRE SCADA system is placed in a turbine the GMS components (HPPP / GMS) may be arranged otherwise.

### **Signal exchange**

Online signal exchange and communications with third party systems such as substation control systems, remote control systems, and/or maintenance systems is possible from both the module and/or the SGRE SCADA server panel. For communication with third party equipment a Modbus TCP, IEC 60870-5-104, and OPC XML compatible interfaces are available as an option.

### **SGRE SCADA software**

The normal SGRE SCADA user interface presents online and historical data. The screen displays can be adjusted to meet individual customer requirements.

Historical data are stored in an MS SQL database as statistical values and can be presented directly on the screen or exported for processing in MS Access or Excel via a ODBC connection.

The SGRE SCADA software also serves as user interface to the HPPP functions.

### **Virus protection solution**

A virus protection solution can be offered as a part of the Service Agreement(SA). An anti-virus client software will in that case be installed on all MS-Windows based components at the SCADA system and the WTGs.

The virus protection solution is based on a third party anti-virus product. Updates to the anti-virus client software and pattern files are automatically distributed from central SGRE based servers.

### **Back-up & restore**

For recovery of a defect SCADA system or component, the SGRE SCADA system provides back-up of configuration files and basic production data files. Both configuration and selected production data are backed up automatically on a regular time basis for major components. The back-up files are stored both locally on the site servers and remotely on SGRE back-up storage servers.

## Codes and Standards

The wind turbine is designed and certified with an external certification body according to:

- 1) Operational Document: OD-501, Type Certification Scheme
- 2) OD501-T01 Type Certificate & Provisional Type Certificate template Wind Turbine
- 3) IEC 61400-22:2010 Ed.1, Wind turbines – Part 22: Conformity testing and certification
- 4) EN 61400-1:2018, Ed.4, Wind turbine generator systems Part 1: Safety requirements, (IEC 61400-1:2005, modified)
- 5) IEC 61400-1:2018 Ed.4 Wind turbines –. Part 1: Design requirements
- 6) DIBt - Richtlinie für Windenergieanlagen - Oktober 2012, korrigierte Fassung März 2015
- 7) IEC 61400-11:2006, Wind turbine generator systems Part 11: Acoustic noise measurement techniques
- 8) IEC 61400-12:2005, Ed.1, Wind Turbine Generator Systems Part 12: Wind turbines power performance testing
- 9) IEC 61400-13: 2015 Wind Turbine Generator Systems - Part 13: Measurement Of Mechanical Loads
- 10) IEC 61400-23 Ed. 1.0 EN :2014 Wind turbines - Part 23: Full-scale structural testing of rotor blades
- 11) VDI 2230 Blatt 1, 2016, Bolt calculation
- 12) ISO 898-1:2013 Mechanical properties of fasteners made of carbon steel and alloy steel -- Part 1: Bolts, screws and studs with specified property classes -- Coarse thread and fine pitch thread
- 13) EN 10029:2010, Hot rolled steel plates 3 mm thick or above - Tolerances on dimensions, shape and mass
- 14) DS/EN 10083:2008, Quenched and tempered steels - Part 1: Technical delivery conditions for special steels (Main shaft)
- 15) DS/EN 1563:2012, Founding - Spheroidal graphite cast irons
- 16) DS/EN 10025-1:2004, Hot rolled products of structural steels - Part 1: General technical delivery conditions
- 17) DS/EN 10025-2:2006, Hot rolled products of structural steels - Part 2: Technical delivery conditions for non-alloy structural steels
- 18) DS/EN 10025-3:2004, Hot rolled products of structural steels - Part 3: Technical delivery conditions for normalized/normalized rolled weldable fine grain structural steels
- 19) EN 1993-1-8:2005/AC:2009: Eurocode 3: Design of steel structures
- 20) EN 1999 Design of aluminium structures
- 21) ISO/TS 16281:2008 Rolling bearings - Methods for calculating the modified reference rating life for universally loaded bearings
- 22) DIN ISO 281 Rolling bearings - Dynamic load ratings and rating life - Life modification factor aDIN and calculation of the modified rating life
- 23) DIN ISO 76:2006 Rolling bearings - Static load ratings
- 24) ISO/TS 16281:2008 + Cor. 1:2009 Rolling bearings - Methods for calculating the modified reference rating life for universally loaded bearings
- 25) DNV-DS-J102:2010 Design and Manufacture of Wind Turbine Blades, Offshore and Onshore Wind Turbines
- 26) OD-501-2ed.1.0 Conformity Assessment and Certification of wind turbine gearboxes by RECB

- 
- 27) [IEC 61400-4:2012](#) Wind turbines -- Part 4: Design requirements for wind turbine gearboxes
  - 28) EN 61000-6-2:2005 Electromagnetic compatibility (EMC) - Part 6-2: Generic standards – Immunity for industrial environments
  - 29) EN 61000-6-4:2007 Electromagnetic compatibility (EMC) - Part 6-4: Generic standards - Emission standard for industrial environments
  - 30) EN 60204-1:2006 (+correct 2010) Safety of machinery - Electrical equipment of machines - Part 1: General requirements
  - 31) EN 61439-1:2014 Low-voltage switchgear and control gear assemblies. General rules
  - 32) EN 61439-2:2011 Low-voltage switchgear and control gear assemblies. Power switchgear and control gear assemblies
  - 33) [IEC 61400-24 Ed. 1.0](#) (2010) Wind turbines - Part 24: Lightning protection
  - 34) DS/EN 60076 – 16:2018 – Power transformers - Part 16: Transformers for wind turbine applications
  - 35) IEC 61400-21:2008 Wind turbine generator systems - Part 21: Measurement and assessment of power quality characteristics of grid connected wind turbines
  - 36) Low Voltage Directive 2014/35/EU
  - 37) EMC Directive 2014/30/EU
  - 38) EN 61000-6-2:2005 Electromagnetic compatibility (EMC) - Part 6-2: Generic standards – Immunity for industrial environments
  - 39) ISO 9001:2015 Quality management systems – Requirements 2004/108/EF EMC Directive

---

## Other Performance Features

Siemens Gamesa Renewable Energy (SGRE) offers the following optional performance features for SG 6.0-170 that can optimize your wind farm by boosting performance, enhancing environmental agility, supporting compliance with legal regulation, and supporting grid stability.

### **High Temperature Derated operational mode (also known as Power Derating due to component temperature)**

Ventilation and cooling systems are designed to allow the WTG operation at rated power up to a certain external nominal temperature and a certain altitude. For sites located beyond 1000m above the sea level, the air density reduction affects the turbine components ventilation capacity, reducing the maximum operational temperature at rated power. However, this maximum ambient temperature can be extended by reducing the delivered power.

Considering the individual components requirements in temperatures at different altitude levels, and their dissipated heat at different power limits, several curves power-temperature will be generated. These curves will define the envelopes inside which SG 6.0-170 could operate assuring the integrity of all components.

The control system, considering the defined turbine type, will dynamically adjust the maximum allowed power as a function of component temperature.

### **Ice Detection System**

A default IDS is included in SG 6.0-170. This system is required in order to prevent the turbine operating under non desirable ice conditions that could represent an out-of-design situation with risk for the turbine integrity or H&S.

The default IDS can be improved by application of additional features, described as follows:

- Ice on nacelle sensor (optional kit). Additional sensor is installed to detect ice on nacelle.
- Improved ice on blade detection algorithm (optional, only available when blade de-icing system is installed). It requires additional hardware. It is a more complex ice detection algorithm defined based on ice probability calculation, and it is a valuable complement for improving the blade de-icing system performance.

### **Noise Reduction System**

The Noise Reduction System NRS is an optional module available with the basic SCADA configuration and it therefore requires the existence of a SGRE SCADA system to work.

The purpose of this system is to limit the noise emitted by any of the functioning turbines and thereby comply with local regulations regarding noise emissions. This allows wind farms to be located close to urban areas, limiting the environmental impact that they imply.

### **Bat Protection System**

To support the installation of wind turbines in areas that constitute a natural habitat for bats, SGRE has developed a Bat Protection System. Bats are usually more active at certain times of the night and at certain times of the year, depending on the local habitat and/or migration routes. The purpose of the SGRE Bat Protection System is to monitor the local environmental conditions in order to reduce the risk of impact on bats.

Specific environmental conditions can be monitored by means of dedicated additional sensors: temperature, light, humidity and rainfall. If conditions for the existence of bats are met, the Bat Protection System tool will



request the wind turbines to be paused. As soon as one of the conditions is no longer met, the affected wind turbine will return to its initial status prior to receiving the pause order from the tool, depending on the configured hysteresis values.

The tool does not require all the sensors associated with the conditions to be installed and, depending on each site, the sensors needed will be configured. If there is no sensor for a specific environmental variable, condition is configured as fulfilled.

Additionally, Bat Protection System can be configured to be triggered depending on calendar (day/time), wind speed range or wind direction.

### **Bird Detection System**

The Bird Detection System is a stand-alone system that monitors the wind farm's surrounding air space and detects flying birds in real time. At the same time, it is capable of handling real-time actions related to bird detection, such as warning and deterring birds at risk of colliding with the wind turbines or automatic shutdown of the selected wind turbines.