

DIST.PROG. : 0+000.000
SCALA 1:100

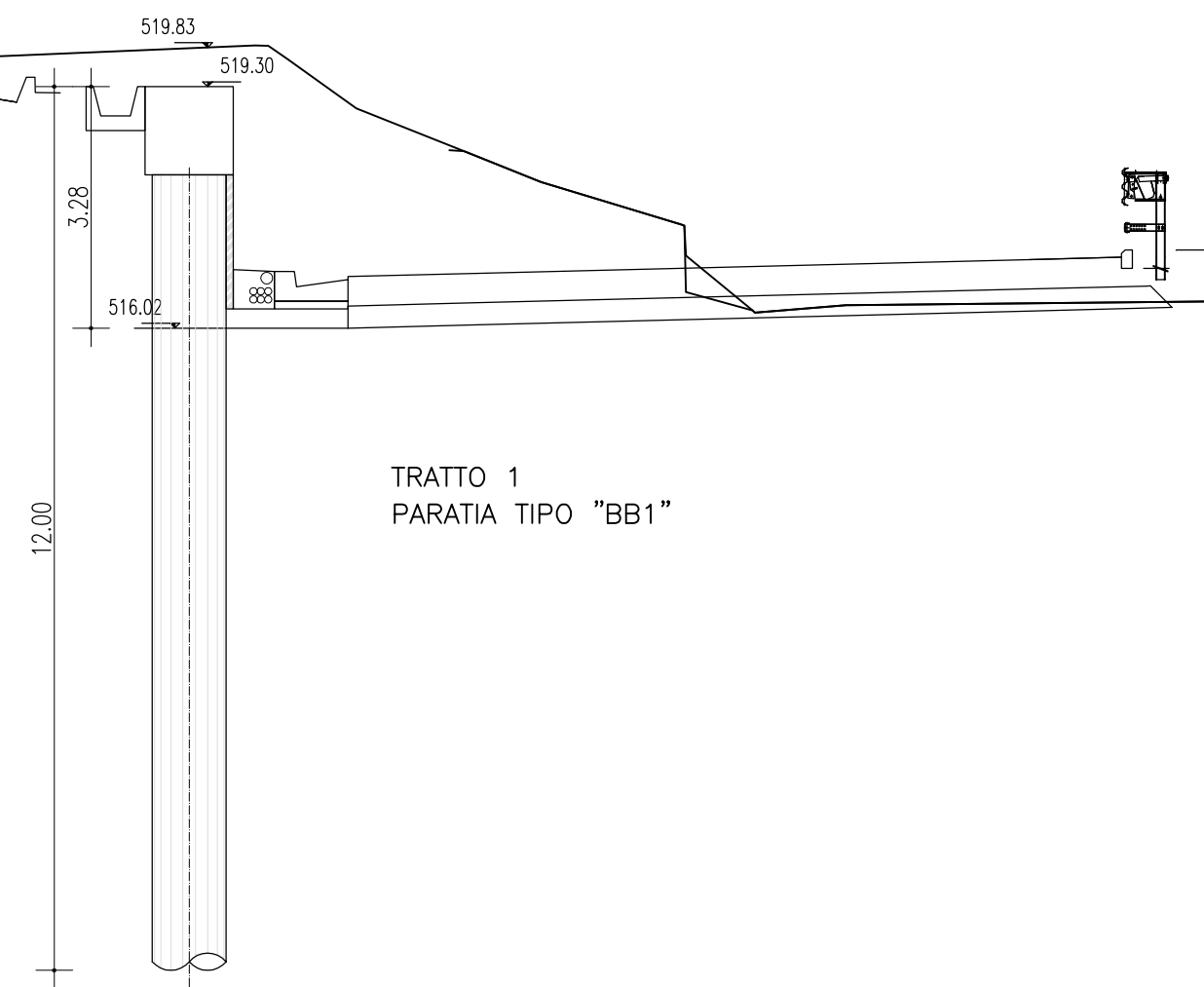

TRATTO 1
PARATIA TIPO "BB1"

DIST.PROG. : 0+010.000
SCALA 1:100

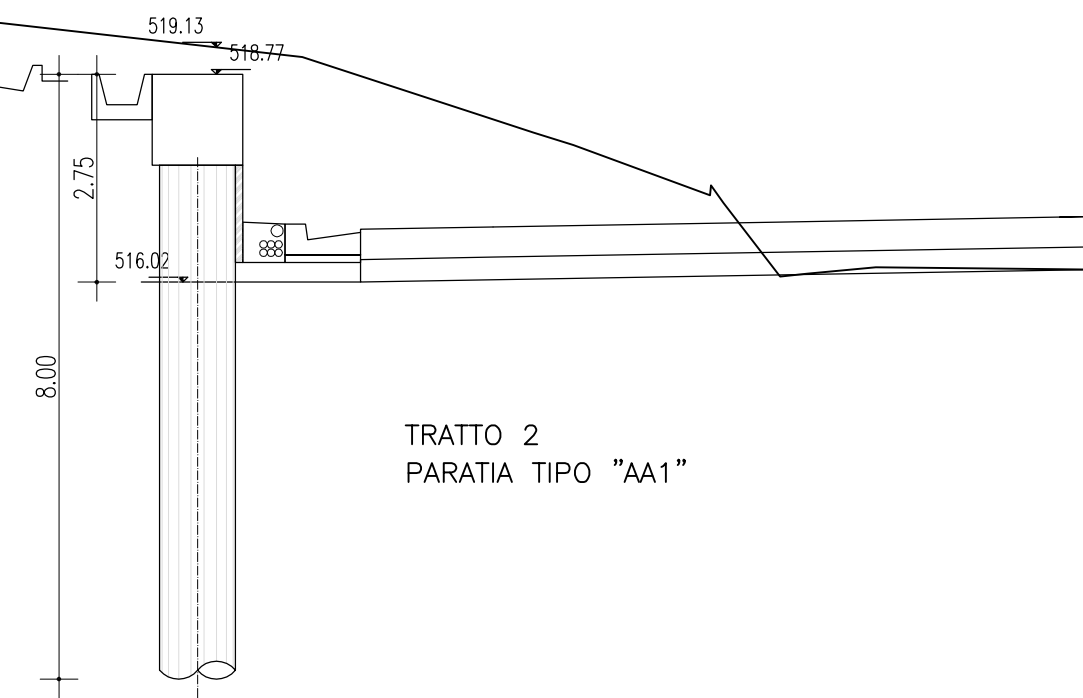

TRATTO 2
PARATIA TIPO "AA1"

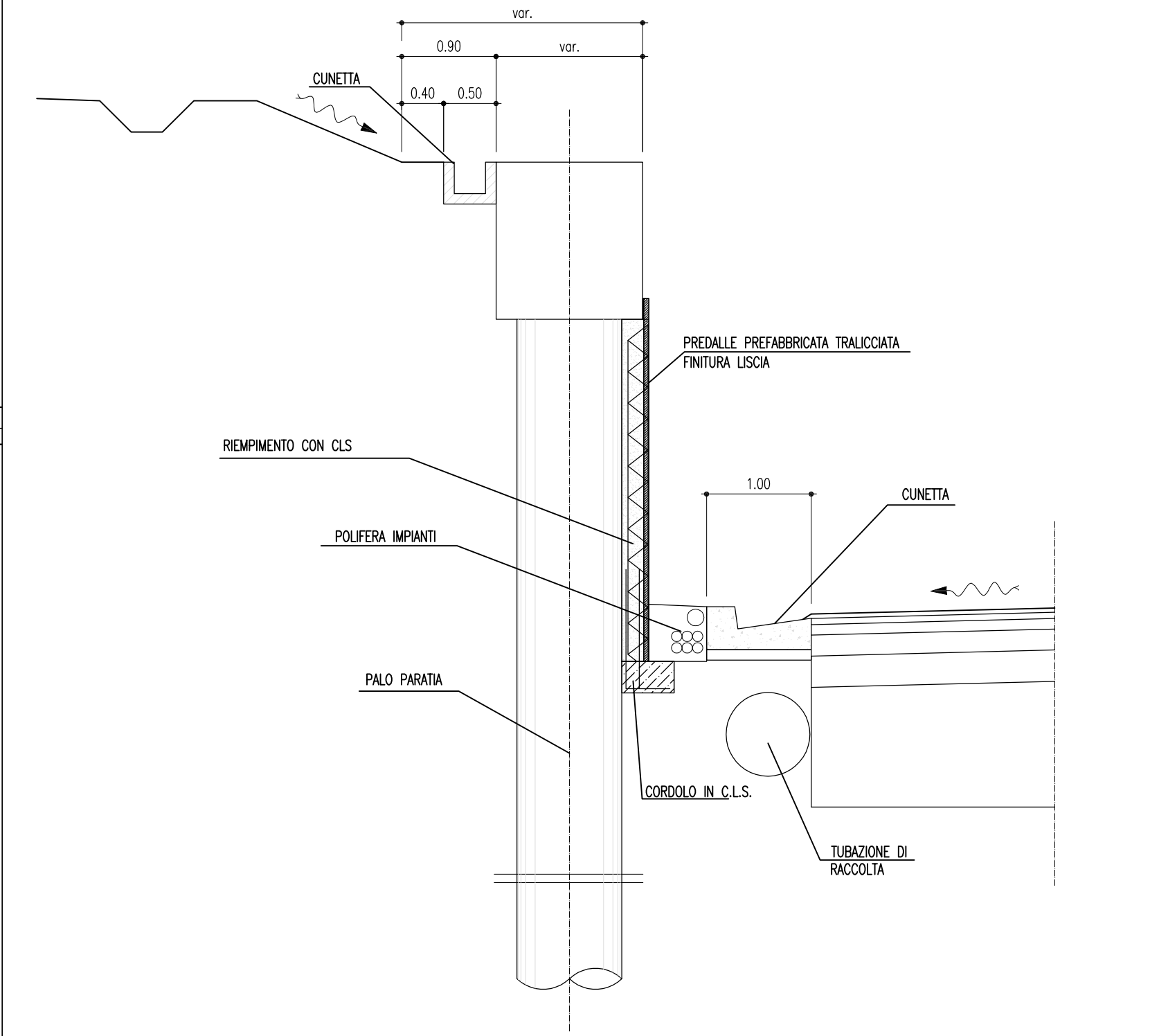

DIST.PROG. : 0+002.756
SCALA 1:100

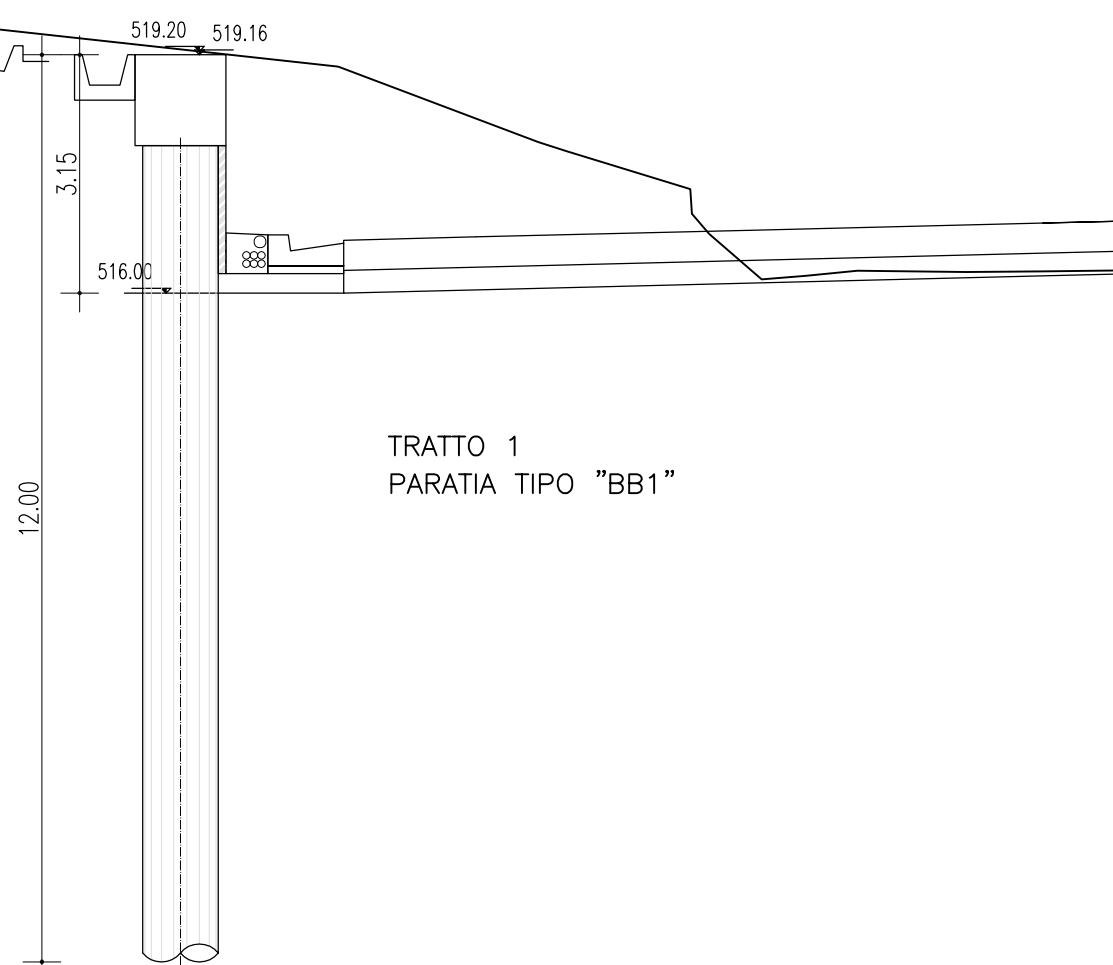

TRATTO 1
PARATIA TIPO "BB1"

DIST.PROG. : 0+015.000
SCALA 1:100

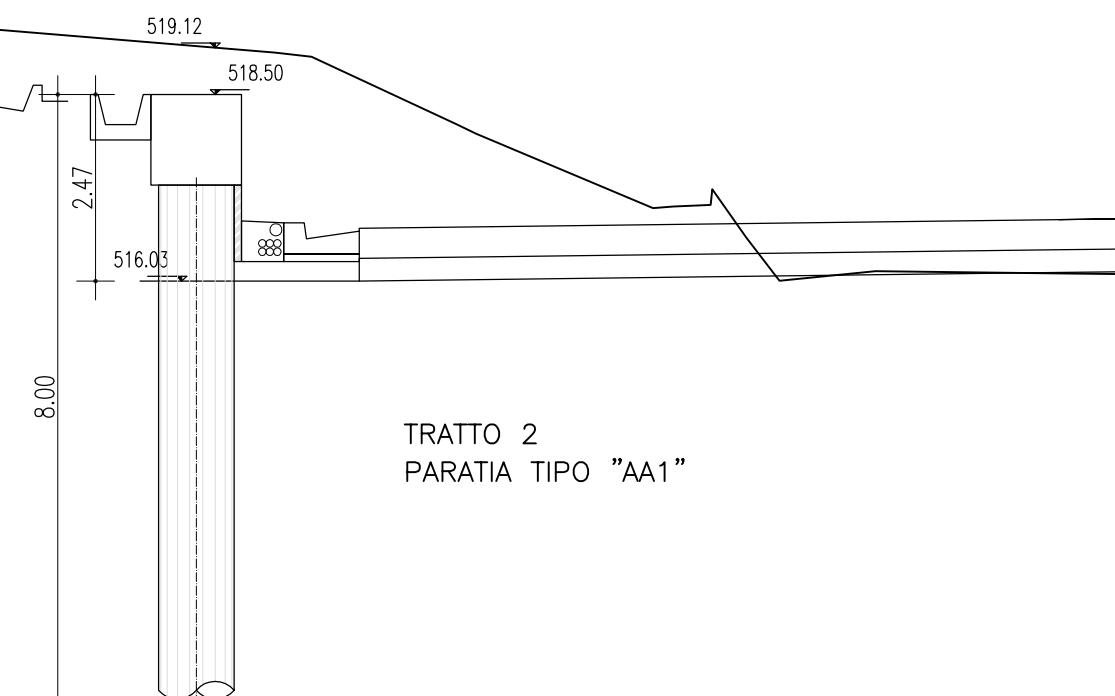

TRATTO 2
PARATIA TIPO "AA1"

DIST.PROG. : 0+005.000
SCALA 1:100

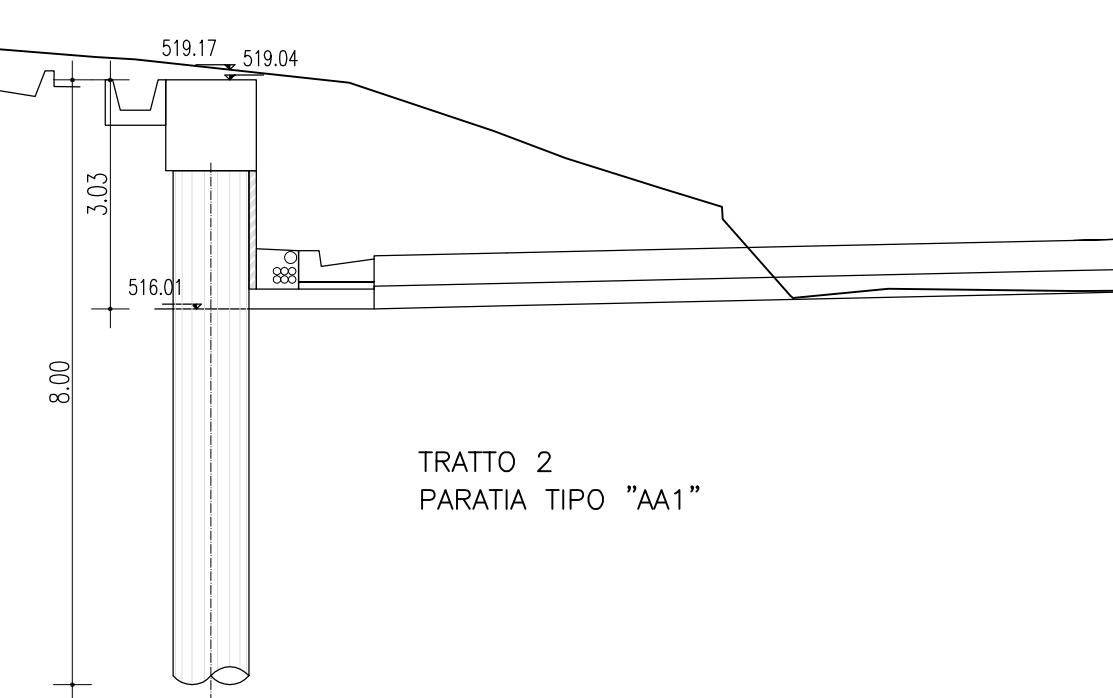

TRATTO 2
PARATIA TIPO "AA1"

DIST.PROG. : 0+020.000
SCALA 1:100

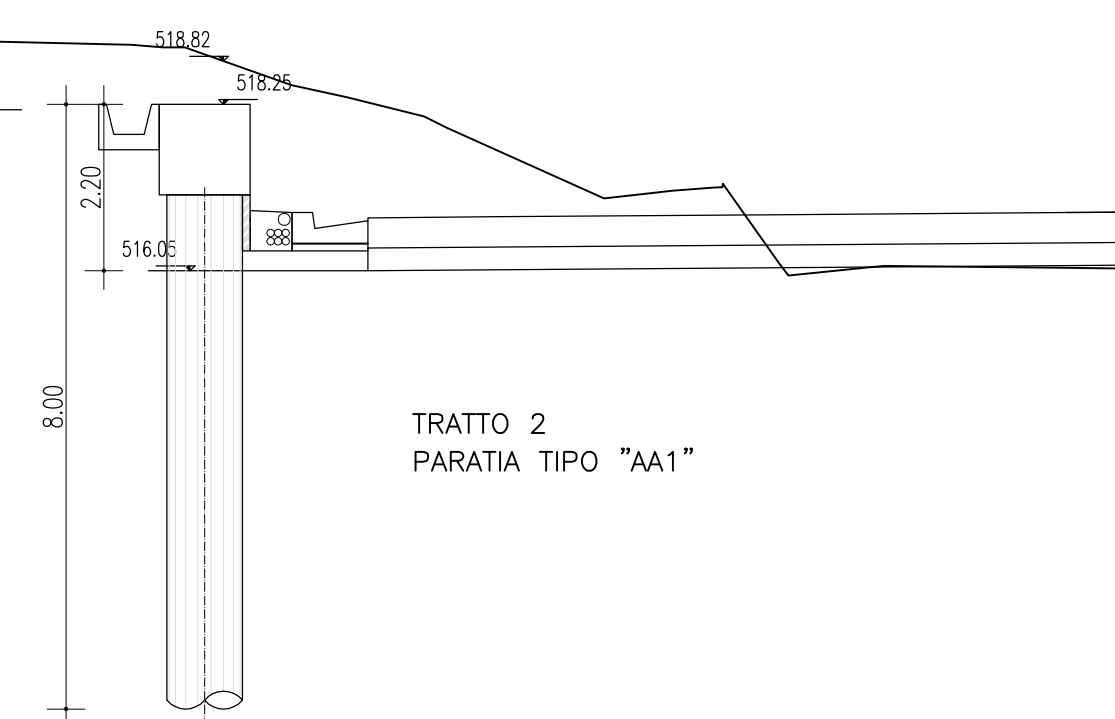

TRATTO 2
PARATIA TIPO "AA1"



ANAS S.p.A.
DIREZIONE CENTRALE PROGRAMMAZIONE PROGETTAZIONE

PA 12/09
CORRIDOIO PLURIMODALE TIRRENICO - NORD EUROPA
ITINERARIO AGRIGENTO - CALTANISSETTA - A19
S.S. N° 640 "DI PORTO EMPEDOCLE"
AMMODERNAMENTO E ADEGUAMENTO ALLA CAT. B DEL D.M. 5.11.2001
Dal km 44+000 allo svincolo con l'A19

PROGETTO ESECUTIVO

Contraente Generale: 

OPERE D'ARTE MINORI
MURI IN C.A.
MP.01 - Paratia di pali in opera 20,70 mt - da 0-000.60 a 0+020.10 -
Sezioni trasversali

Codice Unico Progetto (CUP) : F91B0900070001					
Codice Elaborato:					
PA12_09 - E 0 2 4 T R 2 0 1 M U 0 1 6 W A 0 0 2 A Scale: 1:100					
F					
E					
D					
C					
B					
A	Aprile 2011	EMISSIONE		M. LITI	P. PAGLINI
REV.	DATA	DESCRIZIONE	REDATTO	VERIFICATO	APPROVATO
Responsabile del procedimento: Ing. MAURIZIO ARAMINI					

Il Progettista:



Il Consulente Specialista:



Il Geologo:



Il Coordinatore per la sicurezza in fase di progetto:



Direttore dei lavori:

