

SEZIONE N.B2

PROG. 1226.75
QP = 42.16

ml 21.50 da sez.n. B1 ← → ml 18.60 a sez.n. B3

MOVIMENTI DI TERRA	
R1 =mq	36.89
R =mq	36.89
S =mq	0.00
SCOTICO	
Sc =ml	34.37
BONIFICA	
Bf =mq	17.18
STRATO ANTICAPILLARE	
Sa =mq	10.31
GEOTESSILE	
Gt =ml	36.37
PAVIMENTAZIONE	
Pv =ml	19.02

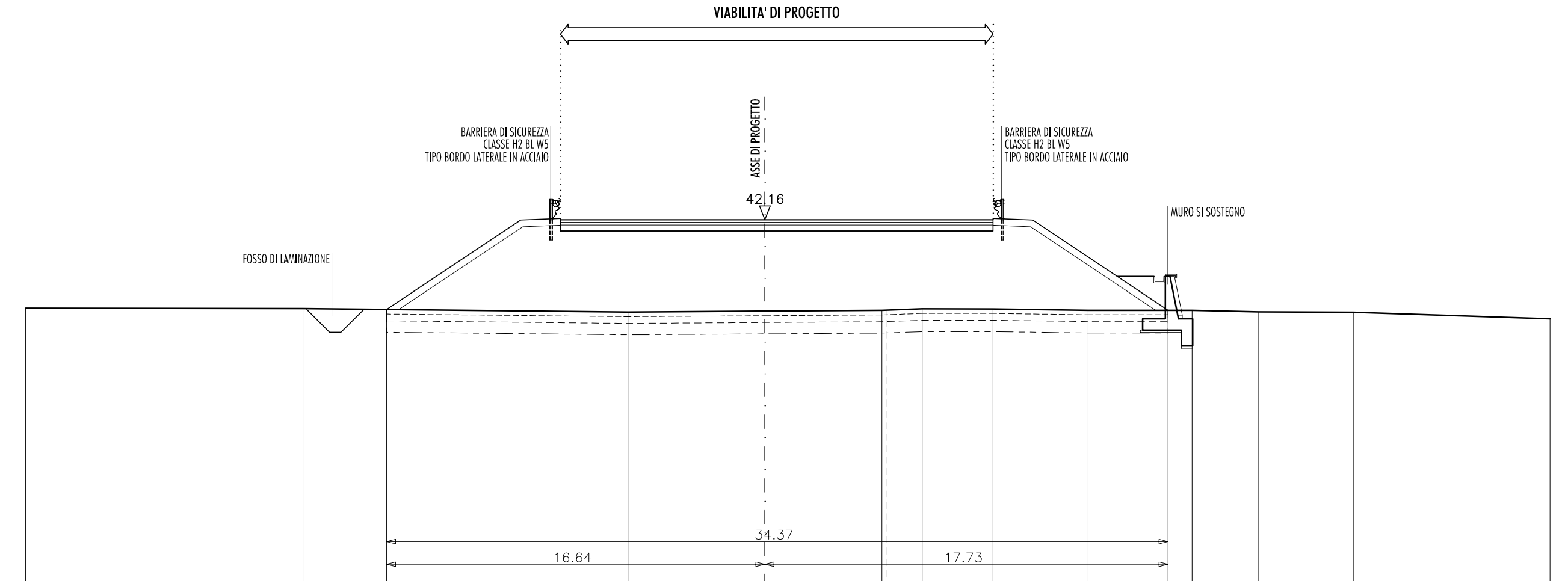
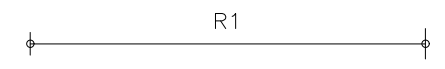

TERRENO	QUOTE	38.27		38.25		38.09	38.13	38.17	38.23	38.23	38.17	38.17	38.11	38.09	37.80
	DIST. PARZ.		12.21		14.29		6.02	5.15	1.77	3.12	4.18	4.57	2.91	4.18	8.66
PAVIMENTAZIONE	QUOTE						42.16	42.16		42.16					
	DIST. PARZ.					8.99		10.03							
PROGETTO	QUOTE		38.21	42.14	42.21	41.66	41.66	41.66	42.21	42.14	38.17				
	DIST. PARZ.			5.90	1.75	8.99		10.03	1.75	5.95					

SEZIONE N.B3

PROG. 1245.35
QP = 42.26

ml 18.60 da sez.n. B2 ← → ml 20.00 a sez.n. B4

MOVIMENTI DI TERRA	
R1 =mq	74.54
R =mq	74.54
S =mq	0.00
SCOTICO	
Sc =ml	38.80
BONIFICA	
Bf =mq	19.40
STRATO ANTICAPILLARE	
Sa =mq	11.64
GEOTESSILE	
Gt =ml	40.80
PAVIMENTAZIONE	
Pv =ml	10.46

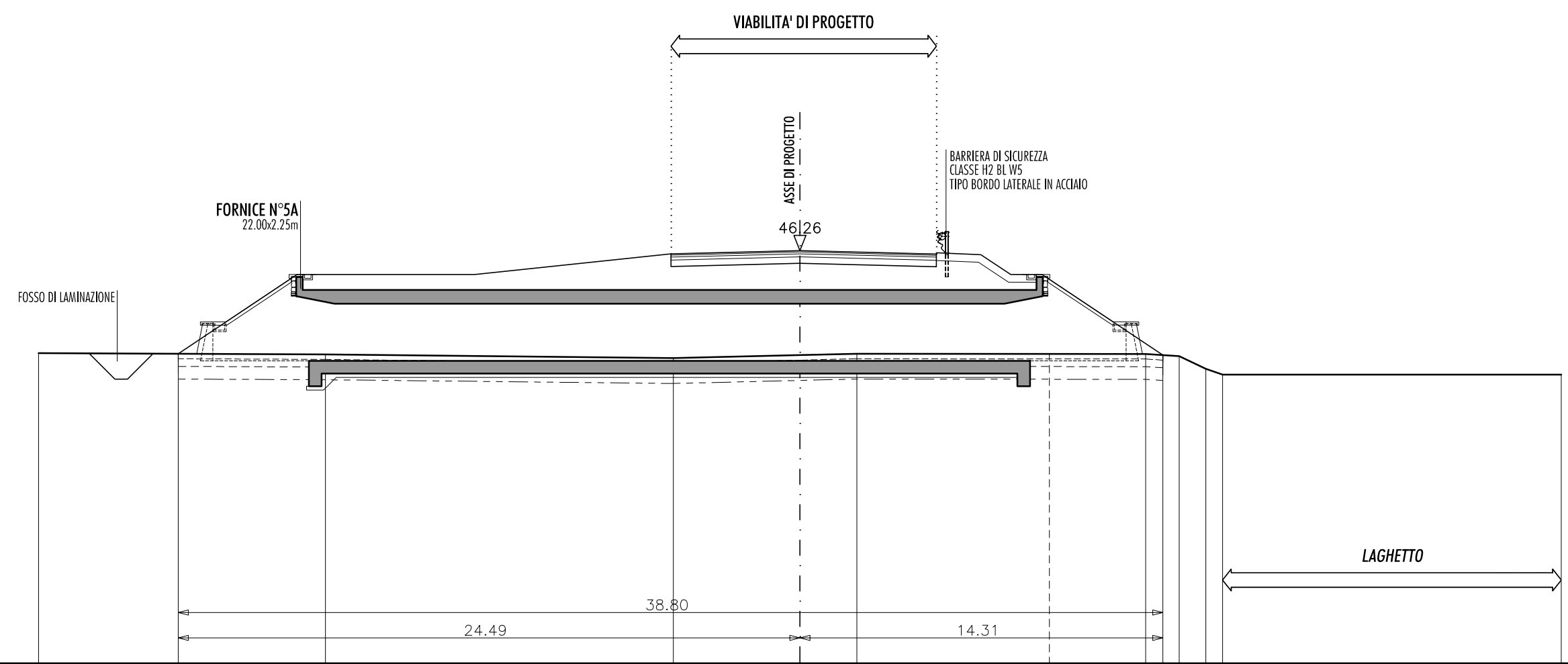
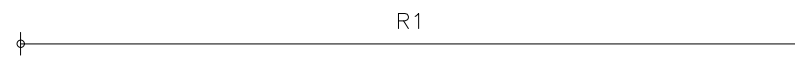

TERRENO	QUOTE	38.22		38.17		38.03		38.15		38.20		38.19	38.10	37.60	37.38		37.38
	DIST. PARZ.		11.31		13.70		4.99	2.24		11.38		1.32	1.05	0.66		13.35	
PAVIMENTAZIONE	QUOTE					42.13		42.26		42.12							
	DIST. PARZ.						5.08		5.38								
PROGETTO	QUOTE	38.20	41.32	41.32		42.13	41.63	41.76		41.62	42.17	42.10	41.32	41.32		38.15	
	DIST. PARZ.		4.68	7.01		7.72		5.08		5.38	1.75	1.18	1.24		4.76		

SEZIONE N.B4

PROG. 1265.35
QP = 42.36

ml 20.00 da sez.n. B3 ← → ml 20.00 a sez.n. B5

MOVIMENTI DI TERRA	
R1=mq	117.69
R =mq	117.69
S =mq	0.00
SCOTICO	
Sc =ml	42.76
BONIFICA	
Bf =mq	21.38
STRATO ANTICAPILLARE	
Sa =mq	12.83
GEOTESSILE	
Gt =ml	44.76
PAVIMENTAZIONE	
Pv =ml	20.64

R1

VIABILITA' DI PROGETTO

BARRIERA DI SICUREZZA
CLASSE H2 BL W5
TIPO BORDO LATERALE IN ACCIAIO

FORNICE N°5A
22.00x2.25m

ASSE DI PROGETTO

42.36

BARRIERA DI SICUREZZA
CLASSE H2 BL W5
TIPO BORDO LATERALE IN ACCIAIO

MURO DI SOSTEGNO

27.00

TERRENO	QUOTE	38.22		38.07	38.16		38.18	37.92	37.90		38.23	38.26
	DIST. PARZ.		13.33	3.07		13.60	6.79	5.21		15.25	2.75	
PAVIMENTAZIONE	QUOTE				42.09		42.36		42.53			
	DIST. PARZ.					10.81	9.83					
PROGETTO	QUOTE	38.16	41.33	41.33	42.07	41.59	41.86	42.03	42.51		38.04	
	DIST. PARZ.	4.75	4.72	2.44	1.75	10.81	9.83	1.75	6.70			

SEZIONE N.B5

PROG. 1285.35
QP = 42.47

ml 20.00 da sez.n. B4 ← → ml 20.00 a sez.n. B6

MOVIMENTI DI TERRA	
R1=mq	135.85
<u>R</u> =mq	<u>135.85</u>
<u>S</u> =mq	<u>0.00</u>
SCOTICO	
Sc =ml	47.67
BONIFICA	
Bf =mq	23.83
STRATO ANTICAPILLARE	
Sa =mq	14.30
GEOTESSILE	
Gt =ml	49.67
PAVIMENTAZIONE	
Pv =ml	31.83

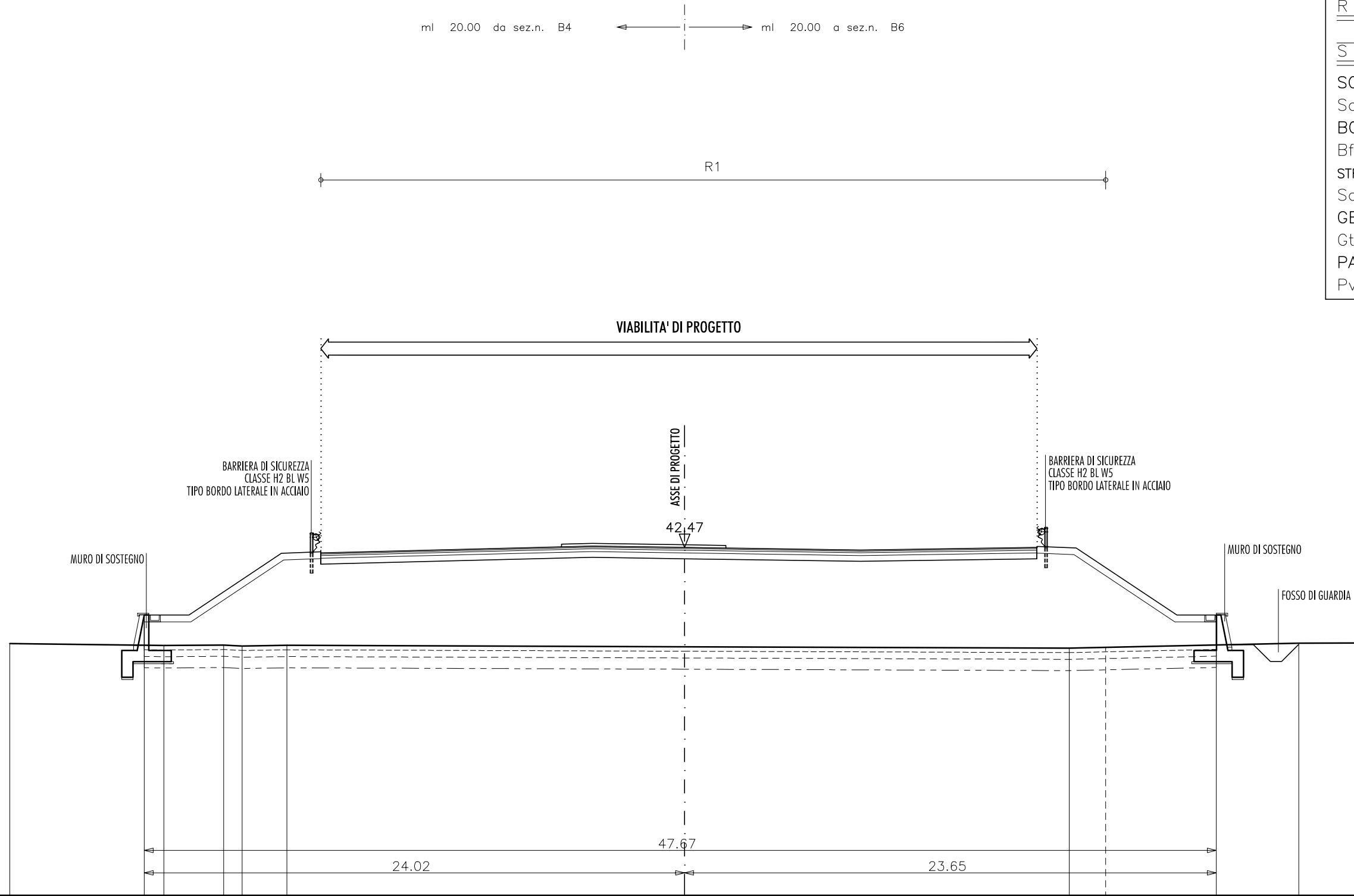

TERRENO	QUOTE	38.19		38.11	38.13	38.09	38.12		38.05		37.99		38.21	38.22					
	DIST. PARZ.		6.85		2.66	0.82	1.99		17.68		17.10		10.20		2.70				
PAVIMENTAZIONE	QUOTE						42.22		42.53	42.47		42.35		42.47					
	DIST. PARZ.						12.07		4.10	7.82		7.84		4.10					
PROGETTO	QUOTE		38.12	39.46		42.20	41.72		42.03	41.97		41.85		41.97	42.52	42.45	39.46	38.46	38.13
	DIST. PARZ.		1.99	4.11		1.75	12.07		4.10	7.82		7.84		1.75	4.48	1.76			

SEZIONE N.B8

PROG. 1345.35
QP = 42.78

ml 20.00 da sez.n. B7 ← → ml 20.00 a sez.n. B9

MOVIMENTI DI TERRA	
R1 = mq	140.82
<u>R = mq</u>	<u>140.82</u>
<u>S = mq</u>	<u>0.00</u>
SCOTICO	
Sc = ml	48.68
BONIFICA	
Bf = mq	24.34
STRATO ANTICAPILLARE	
Sa = mq	14.60
GEOTESSILE	
Gt = ml	50.68
PAVIMENTAZIONE	
Pv = ml	30.80

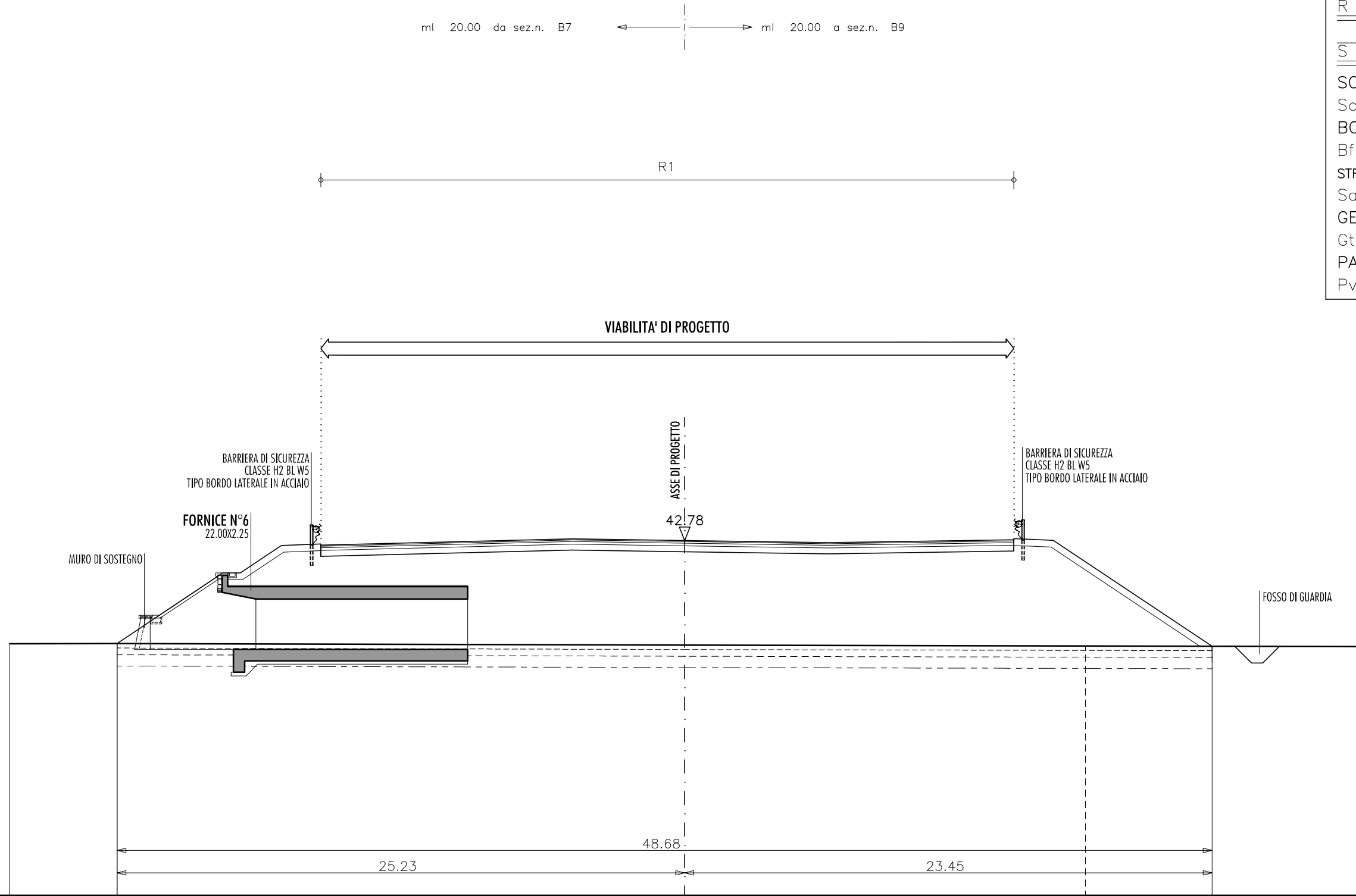

TERRENO	QUOTE	38.19	38.20		38.13								38.06	
	DIST. PARZ.	4.77	25.23		30.00									
PAVIMENTAZIONE	QUOTE		42.57	42.85	42.78	42.68	42.81							
	DIST. PARZ.		11.18	4.99	6.40	8.23								
PROGETTO	QUOTE	38.20	41.33	41.33	42.55	42.82	42.87	42.35	42.28	42.18	42.31	42.86	42.79	38.08
	DIST. PARZ.	4.70	0.78	1.83	1.75	11.18	4.99	6.40	8.23	1.75	7.06		38.08	

SEZIONE N.B11

PROG. 1405.35
QP = 43.09

ml 20.00 da sez.n. B10 ← → ml 20.00 a sez.n. B12

MOVIMENTI DI TERRA	
R1 =mq	55.65
R =mq	55.65
S =mq	0.00
SCOTICO	
Sc =ml	30.77
BONIFICA	
Bf =mq	15.39
STRATO ANTICAPILLARE	
Sa =mq	9.23
GEOTESSILE	
Gt =ml	32.77
PAVIMENTAZIONE	
Pv =ml	13.18

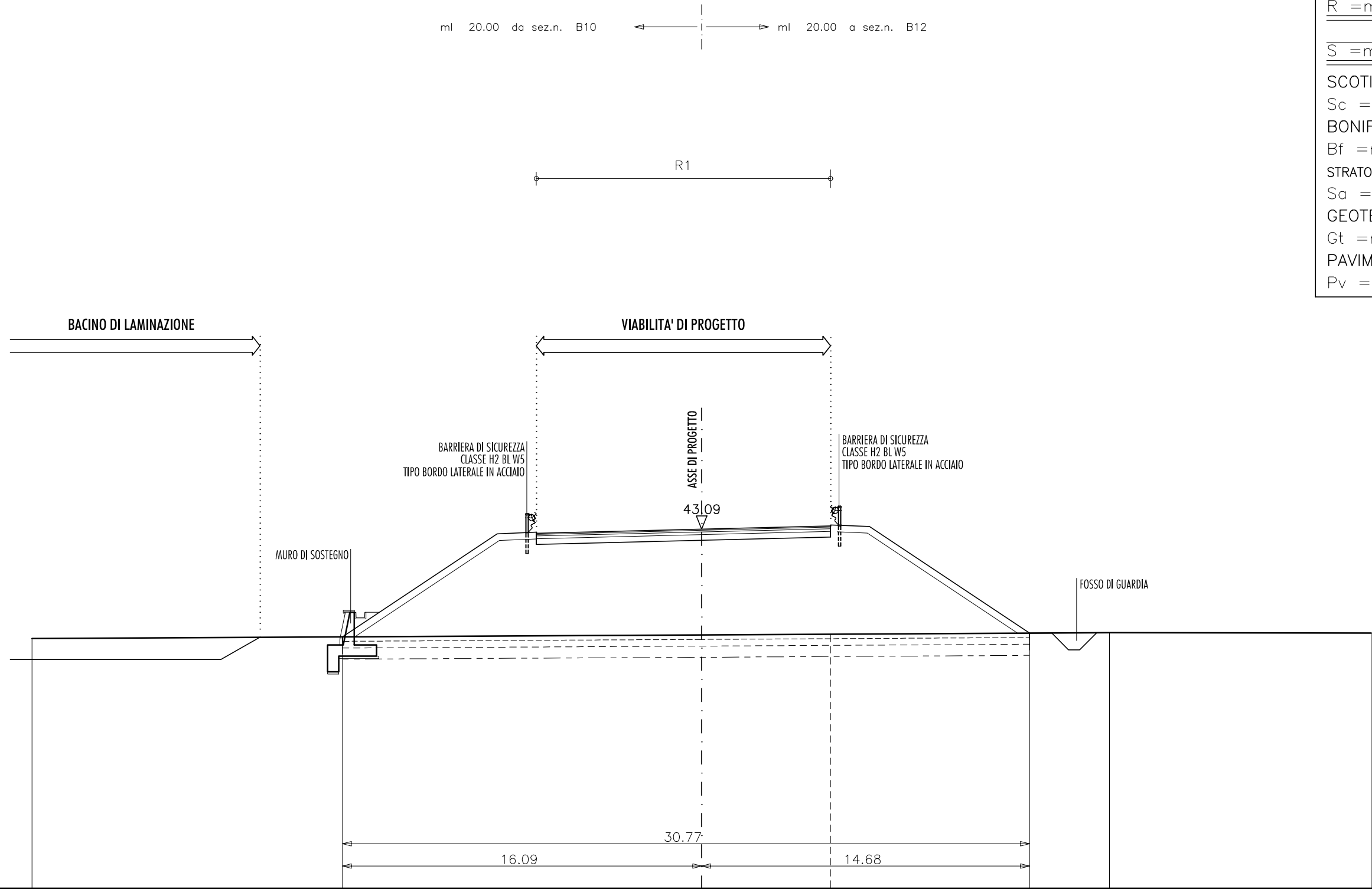

TERRENO	QUOTE	38.20			38.35			38.46		38.44
	DIST. PARZ.		30.00			18.27		11.73		
PAVIMENTAZIONE	QUOTE		42.91		43.09		43.24			
	DIST. PARZ.			7.41		5.77				
PROGETTO	QUOTE	38.27	42.89	42.96	42.94	42.59	42.74	43.29	43.22	38.44
	DIST. PARZ.		6.93	1.75	7.41	5.77	1.75	7.17		

SEZIONE N.B14

PROG. 1465.35
QP = 43.41

ml 20.00 da sez.n. B13 ← → ml 20.00 a sez.n. B15

MOVIMENTI DI TERRA	
R1 =mq	63.49
<u>R =mq</u>	<u>63.49</u>
S =mq	0.00
SCOTICO	
Sc =ml	32.74
BONIFICA	
Bf =mq	16.37
STRATO ANTICAPILLARE	
Sa =mq	9.82
GEOTESSILE	
Gt =ml	34.74
PAVIMENTAZIONE	
Pv =ml	14.02

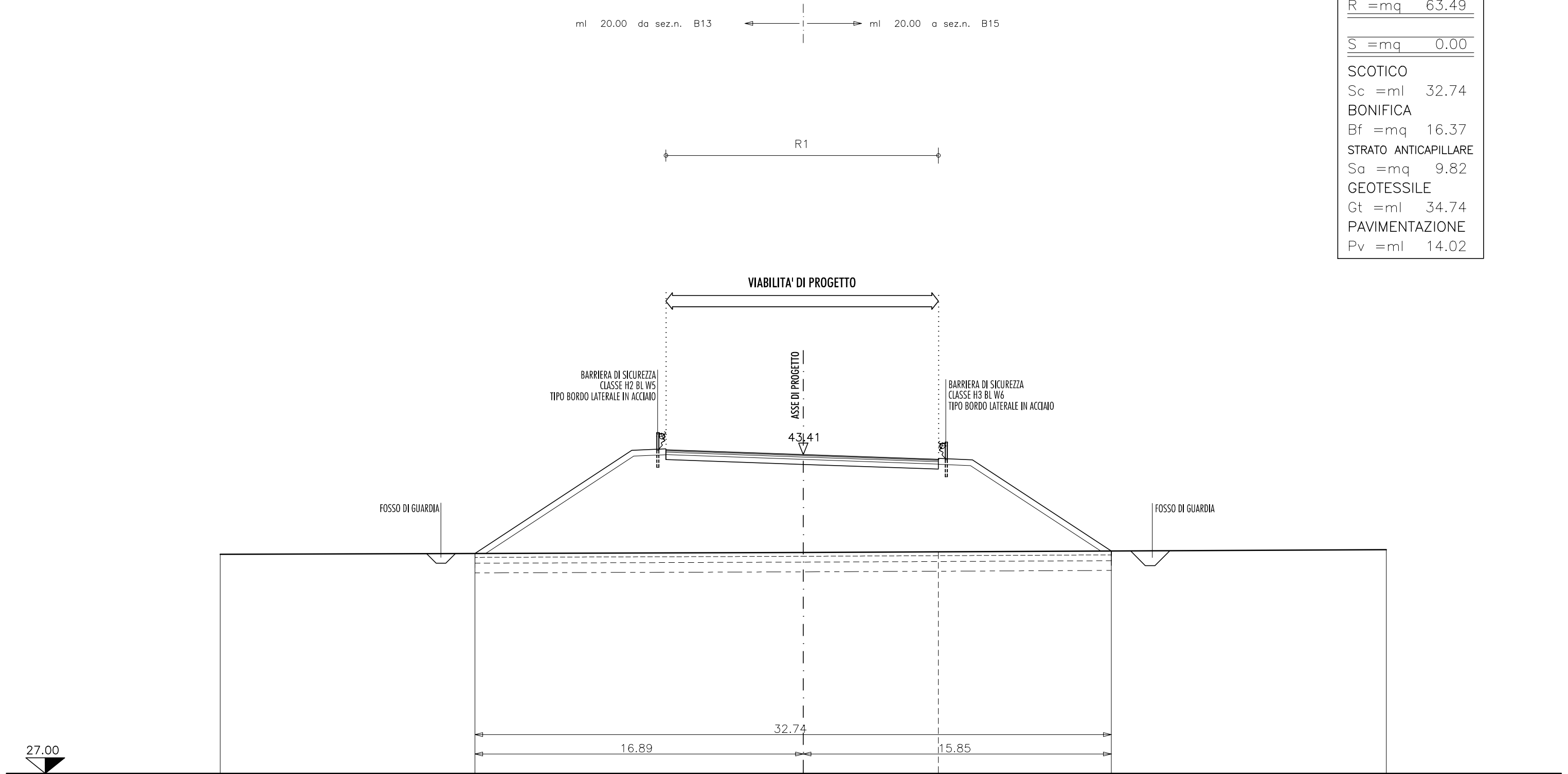

TERRENO	QUOTE	38.28			38.38				38.51	
	DIST. PARZ.		30.00			30.00				
PAVIMENTAZIONE	QUOTE		43.65	43.41	43.16					
	DIST. PARZ.			7.07	6.95					
PROGETTO	QUOTE	38.32	43.63	43.70	43.15	42.91	42.66	43.21	43.14	38.45
	DIST. PARZ.		8.07	1.75	7.07		6.95	1.75	7.15	

SEZIONE N.B15

PROG. 1485.35
QP = 43.59

ml 20.00 da sez.n. B14 ← → ml 14.40 a sez.n. SP1..

MOVIMENTI DI TERRA	
R1 =mq	54.29
R =mq	54.29
S =mq	0.00
SCOTICO	
Sc =ml	30.79
BONIFICA	
Bf =mq	15.39
STRATO ANTICAPILLARE	
Sa =mq	9.24
GEOLESSILE	
Gt =ml	32.79
PAVIMENTAZIONE	
Pv =ml	11.63

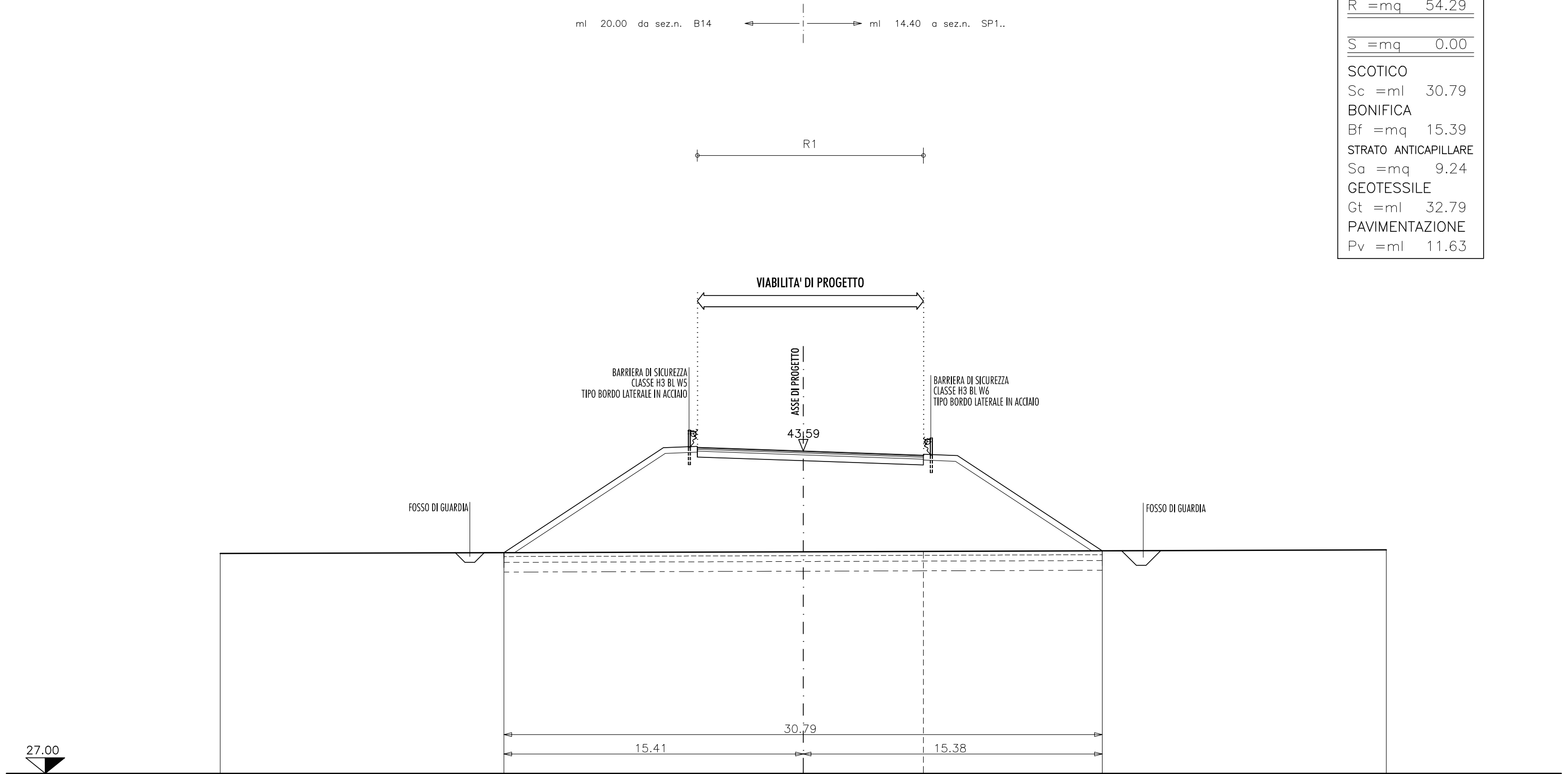

TERRENO	QUOTE	38.32			38.41				38.51
	DIST. PARZ.		30.00			30.00			
PAVIMENTAZIONE	QUOTE			43.78	43.59	43.38			
	DIST. PARZ.			5.45	6.18				
PROGETTO	QUOTE	38.36	43.76	43.88	43.88	43.73	43.36		38.46
	DIST. PARZ.		8.21	1.75	5.45	6.18	1.75	7.45	

SEZIONE N.SP1

PROG. 1499.75
QP = 43.89

ml 14.40 da sez.n. B15 ← → ml 5.60 a sez.n. B16

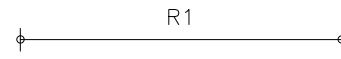

PONTE FIUME BACCHIGLIONE

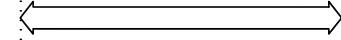

ASSE DI PROGETTO

43.89

PONTE SUL FIUME BACCHIGLIONE
SPALLA 1

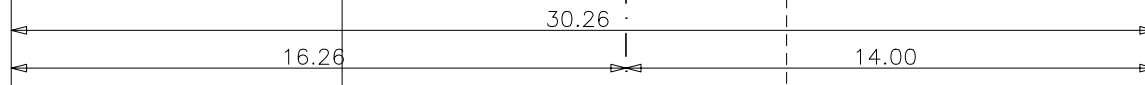

28.00

TERRENO	QUOTE	38.48	38.51	38.46	38.48	38.53						
	DIST. PARZ.	8.95	13.55	7.51	30.00							
PAVIMENTAZIONE	QUOTE			43.97	43.89	43.78						
	DIST. PARZ.			4.25	4.25							
PROGETTO	QUOTE	38.49	39.00	39.02	43.95	44.02	43.47	43.39	43.28	43.83	43.76	38.50
	DIST. PARZ.	0.76	2.00	7.50	1.75	4.25	4.25	1.75	8.00			

SEZIONE N.B16

PROG. 1505.35
QP = 44.03

ml 5.60 da sez.n. SP1.. ← → ml 20.00 a sez.n. B17

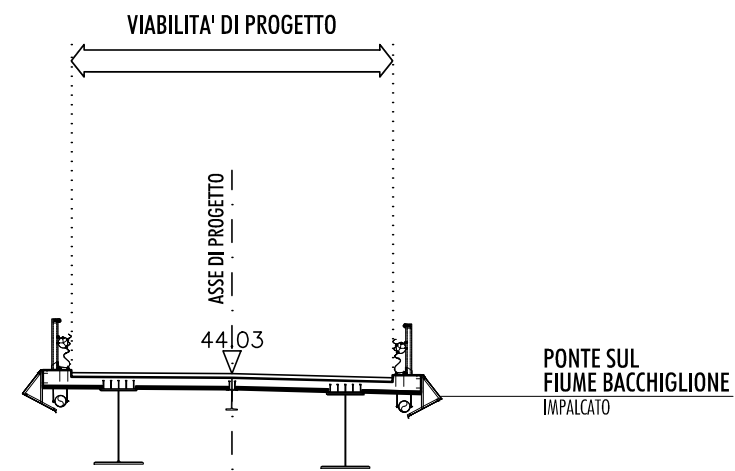

28.00

TERRENO	QUOTE	38.51	38.53	38.48	38.53
	DIST. PARZ.	6.97	23.03	30.00	
PAVIMENTAZIONE	QUOTE		44.06	44.03	43.93
	DIST. PARZ.		4.25	4.25	
PROGETTO	QUOTE		43.98	43.53	43.43
	DIST. PARZ.		1.75	4.25	1.75

SEZIONE N.B17

PROG. 1525.35
QP = 44.56

ml 20.00 da sez.n. B16 ← → ml 14.40 a sez.n. P1

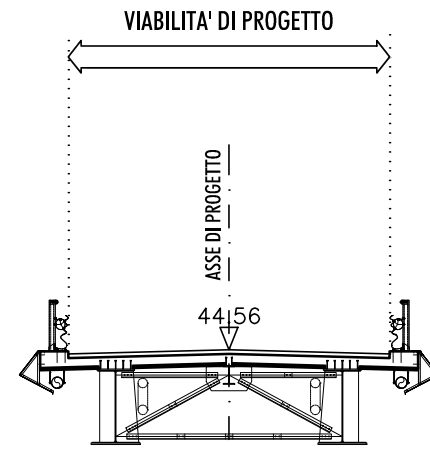

28.00

TERRENO	QUOTE	38.55		38.50		38.54
	DIST. PARZ.		30.00		30.00	
PAVIMENTAZIONE	QUOTE		44.45	44.56	44.45	
	DIST. PARZ.		4.25	4.25		
PROGETTO	QUOTE		44.50	44.06	43.95	44.50
	DIST. PARZ.		1.75	4.25	4.25	1.75

SEZIONE N.P1

PROG. 1539.75
QP = 44.91

ml 14.40 da sez.n. B17 ← → ml 5.60 a sez.n. B18

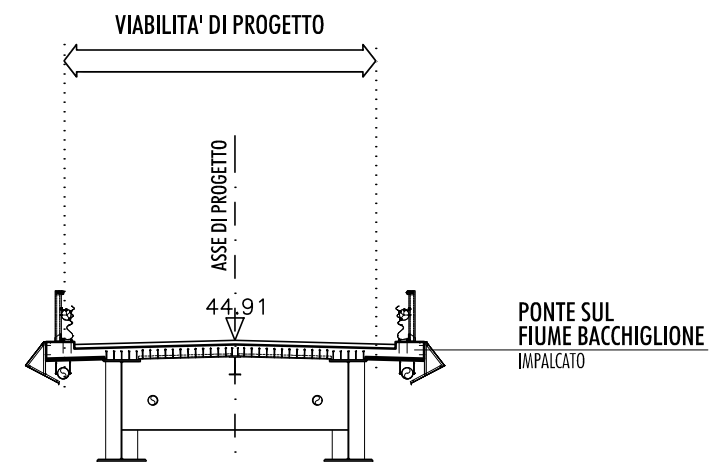

TERRENO	QUOTE	38.50	38.53	38.51	38.54	38.49
	DIST. PARZ.	9.22	20.78	25.26	4.74	
PAVIMENTAZIONE	QUOTE		44.81	44.91	44.81	
	DIST. PARZ.		4.25	4.25		
PROGETTO	QUOTE		44.86	44.41	44.31	44.86
	DIST. PARZ.		1.75	4.25	4.25	1.75

28.00

SEZIONE N.B18

PROG. 1545.35
QP = 45.01

ml 5.60 da sez.n. P1 ← → ml 20.00 a sez.n. B19

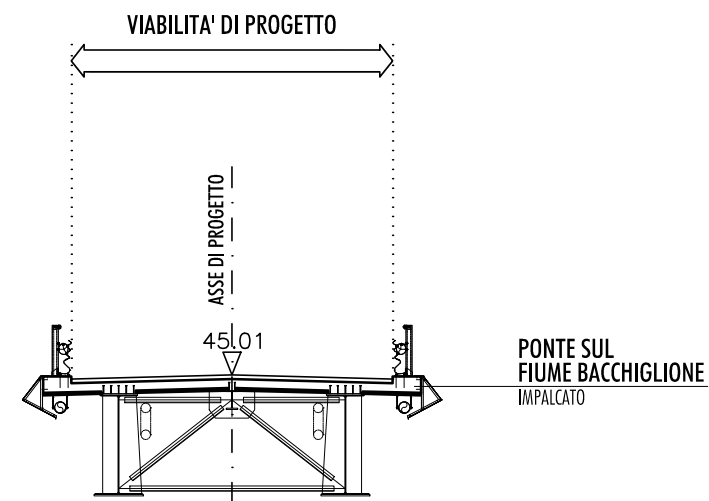

29.00

TERRENO	QUOTE	38.46	38.50	38.43	38.49	38.48	38.51	38.47	38.44
	DIST. PARZ.	4.14	4.42	14.10	7.34	13.97	13.14	2.89	
PAVIMENTAZIONE	QUOTE				44.90	45.01	44.90		
	DIST. PARZ.				4.25	4.25			
PROGETTO	QUOTE				44.95	44.51	44.51	44.95	
	DIST. PARZ.				1.75	4.25	4.25	1.75	

SEZIONE N.B19

PROG. 1565.35
QP = 45.06

ml 20.00 da sez.n. B18 ← → ml 20.00 a sez.n. B20

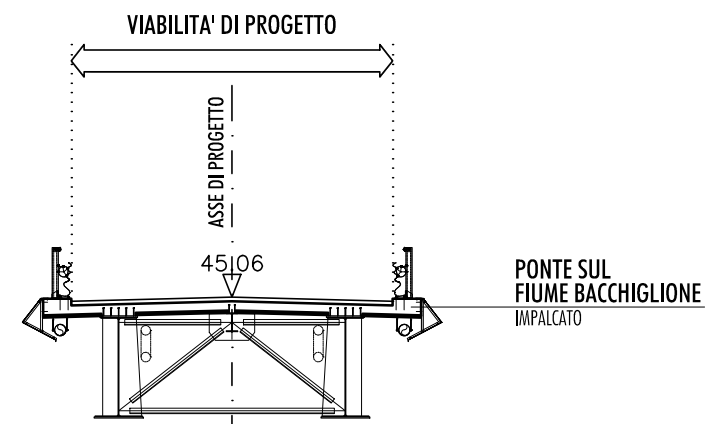

27.00

TERRENO	QUOTE	33.03		32.86	32.93	32.99	32.91	32.86	32.89		32.86
	DIST. PARZ.		19.75		3.66	6.55	3.97		25.56		
PAVIMENTAZIONE	QUOTE				44.95	45.06	44.95				
	DIST. PARZ.				4.25	4.25					
PROGETTO	QUOTE				45.00	44.95	44.56	44.45	45.00	45.00	
	DIST. PARZ.				1.75	4.25	4.25	1.75			

SEZIONE N.B20

PROG. 1585.35
QP = 44.69

ml 20.00 da sez.n. B19 ← → ml 8.40 a sez.n. SP2..

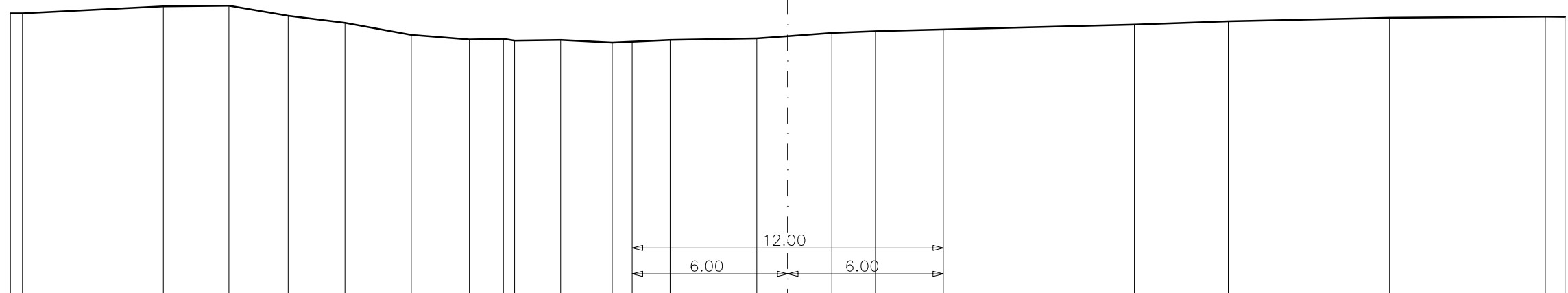
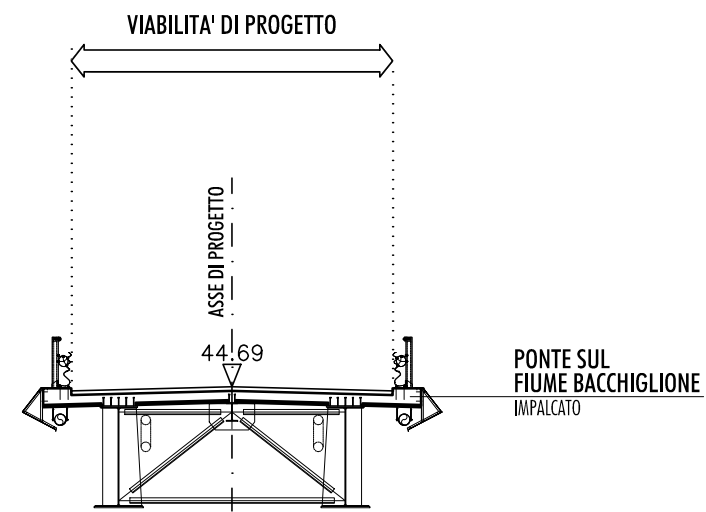

TERRENO	QUOTE	40.04 40.05		40.32	40.34	39.95	39.68	39.21	39.03	39.06 38.99	39.02	38.92	39.02	39.08	39.17	39.29	39.36		39.61	39.74		39.87		39.92 39.90
	DIST. PARZ.	0.47	5.44	2.53	2.28	2.19	2.56	2.25	1.31	0.43	1.78	1.99	2.23	3.34	1.20	1.70	1.68		9.99	3.62	6.22		6.01	0.77
PAVIMENTAZIONE	QUOTE												44.58		44.69		44.58							
	DIST. PARZ.													4.25		4.25								
PROGETTO	QUOTE											44.63	44.63 44.68		44.19		44.63 44.63	44.63						
	DIST. PARZ.											1.75	4.25		4.25		1.75							

SEZIONE N.SP2

PROG. 1593.75

QP = 44.41

ml 8.40 da sez.n. B20

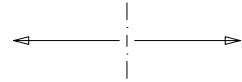

ml 11.60 a sez.n. B21

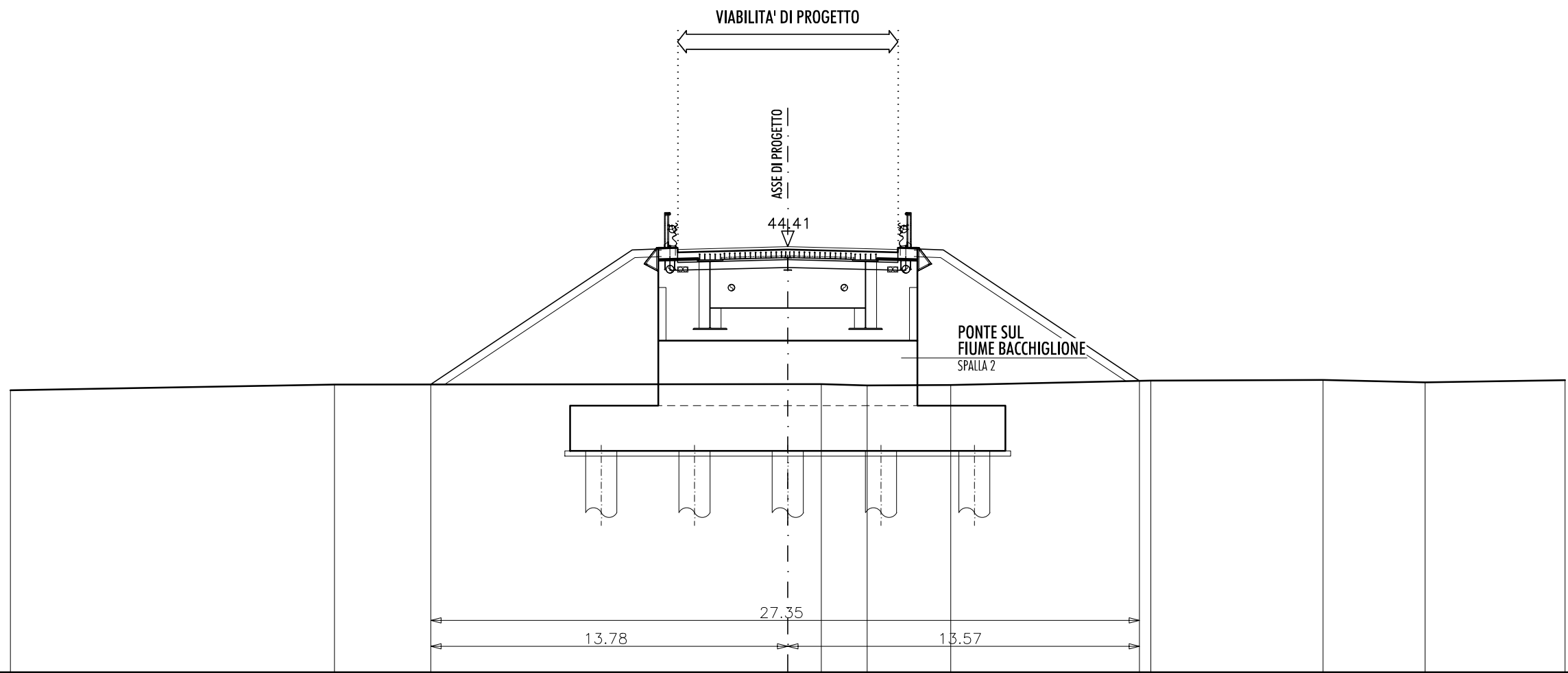

TERRENO	QUOTE	38.87	39.10	39.11	39.11	39.06	39.08	39.24	39.27	39.17	39.26
	DIST. PARZ.	12.51	17.49	1.29	1.77	3.23	7.72	6.65	3.93	5.41	
PAVIMENTAZIONE	QUOTE		44.30	44.41	44.30						
	DIST. PARZ.		4.25	4.25							
PROGETTO	QUOTE	39.10	44.28	43.80	44.35	44.28	39.24				
	DIST. PARZ.	7.78	1.75	4.25	4.25	1.75	7.57				