

ARMATURA FONDAZIONI PILA 2 SX
(SCALA 1 : 50)

Armatura inferiore zattera

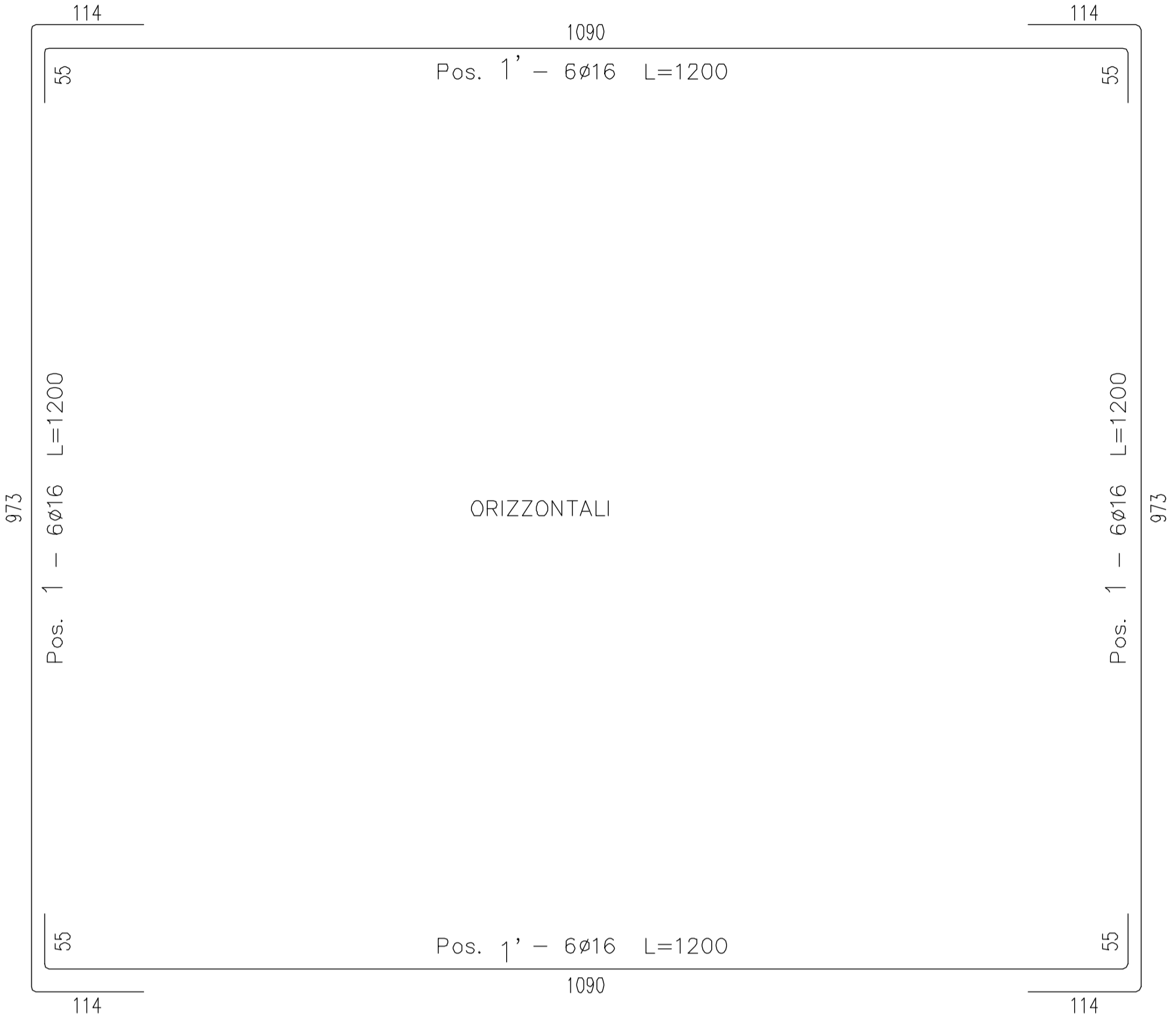

Armatura superiore zattera

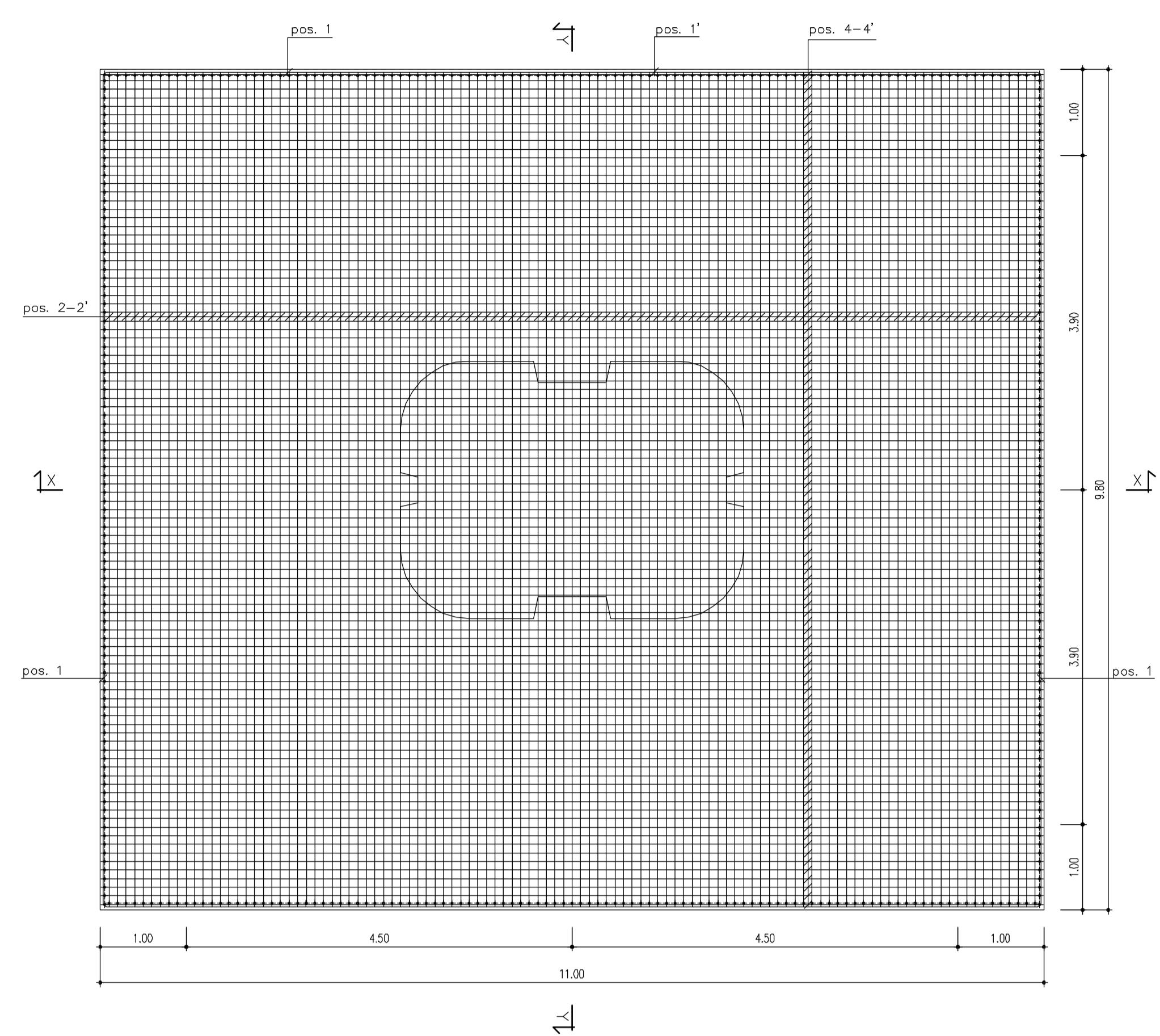
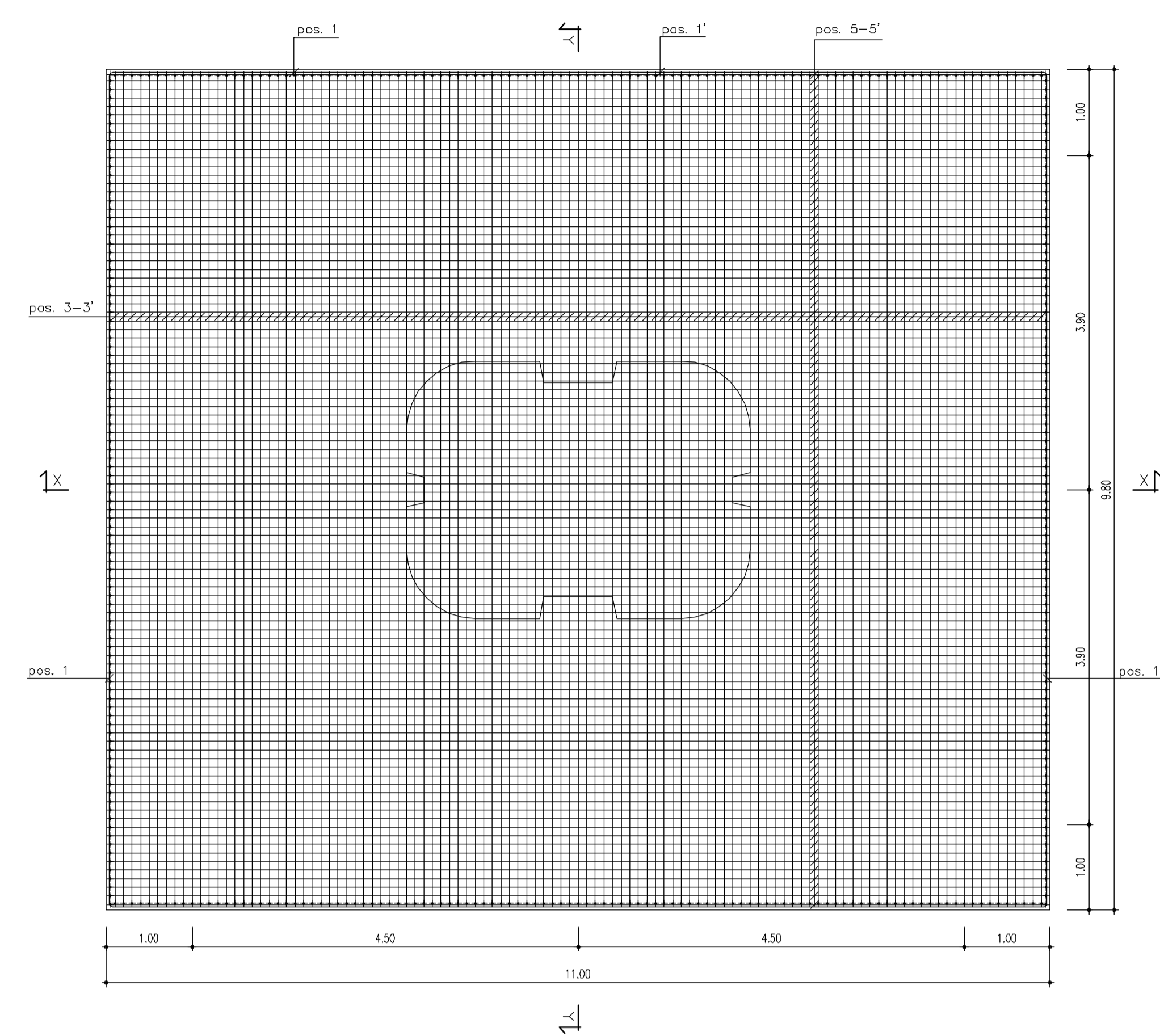

Sezione A-A

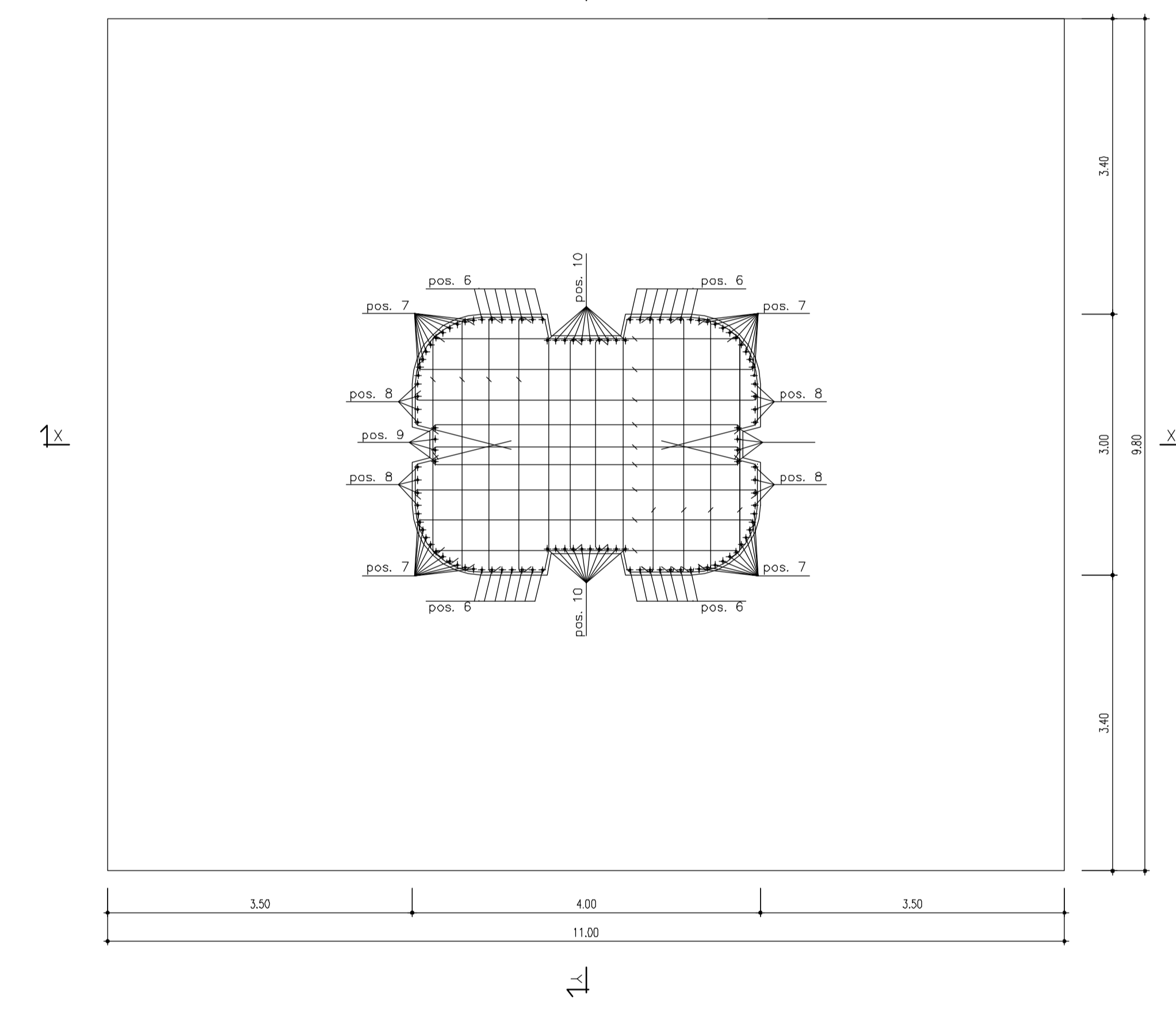

Sezione X-X

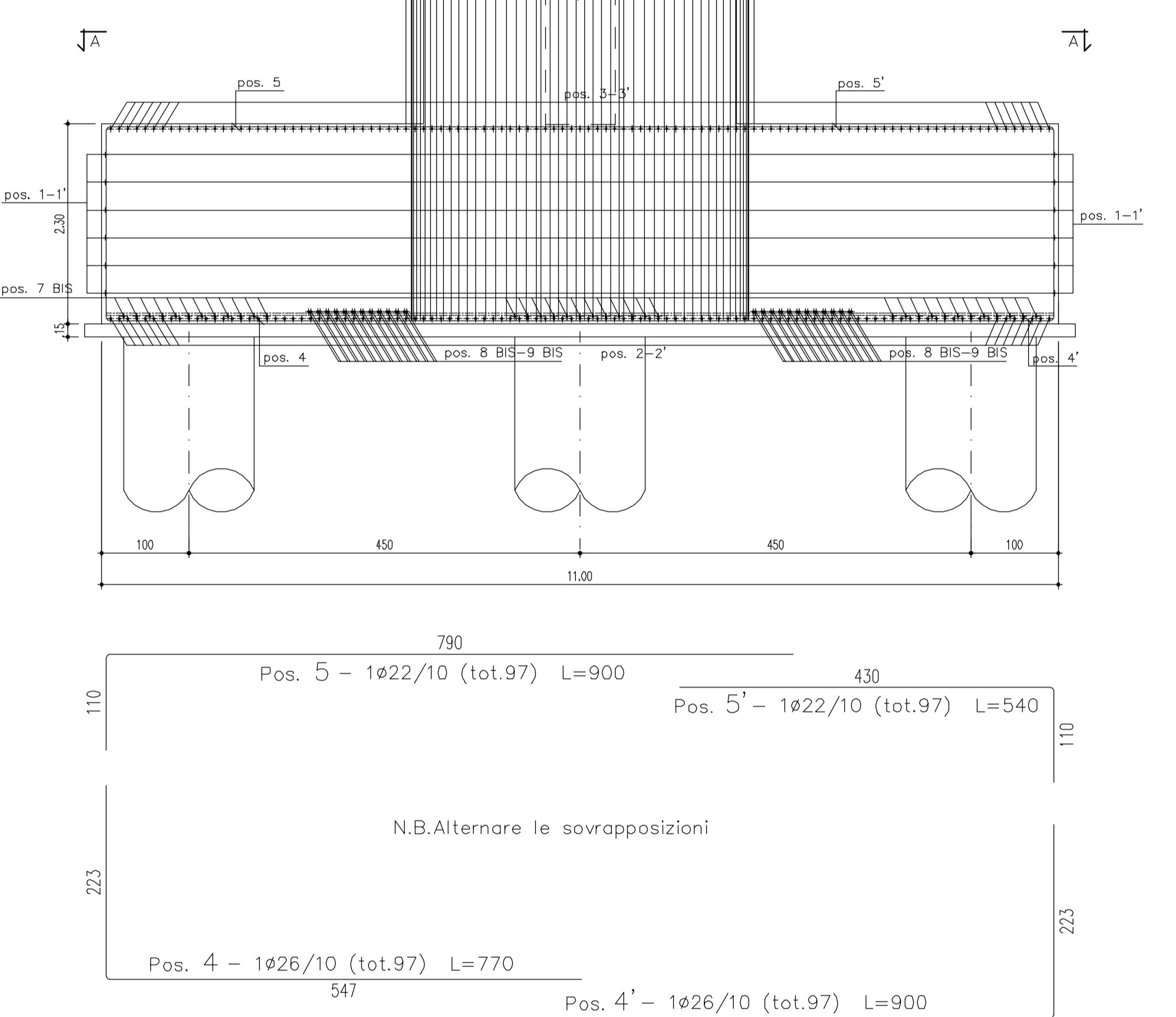

Sezione Y-Y

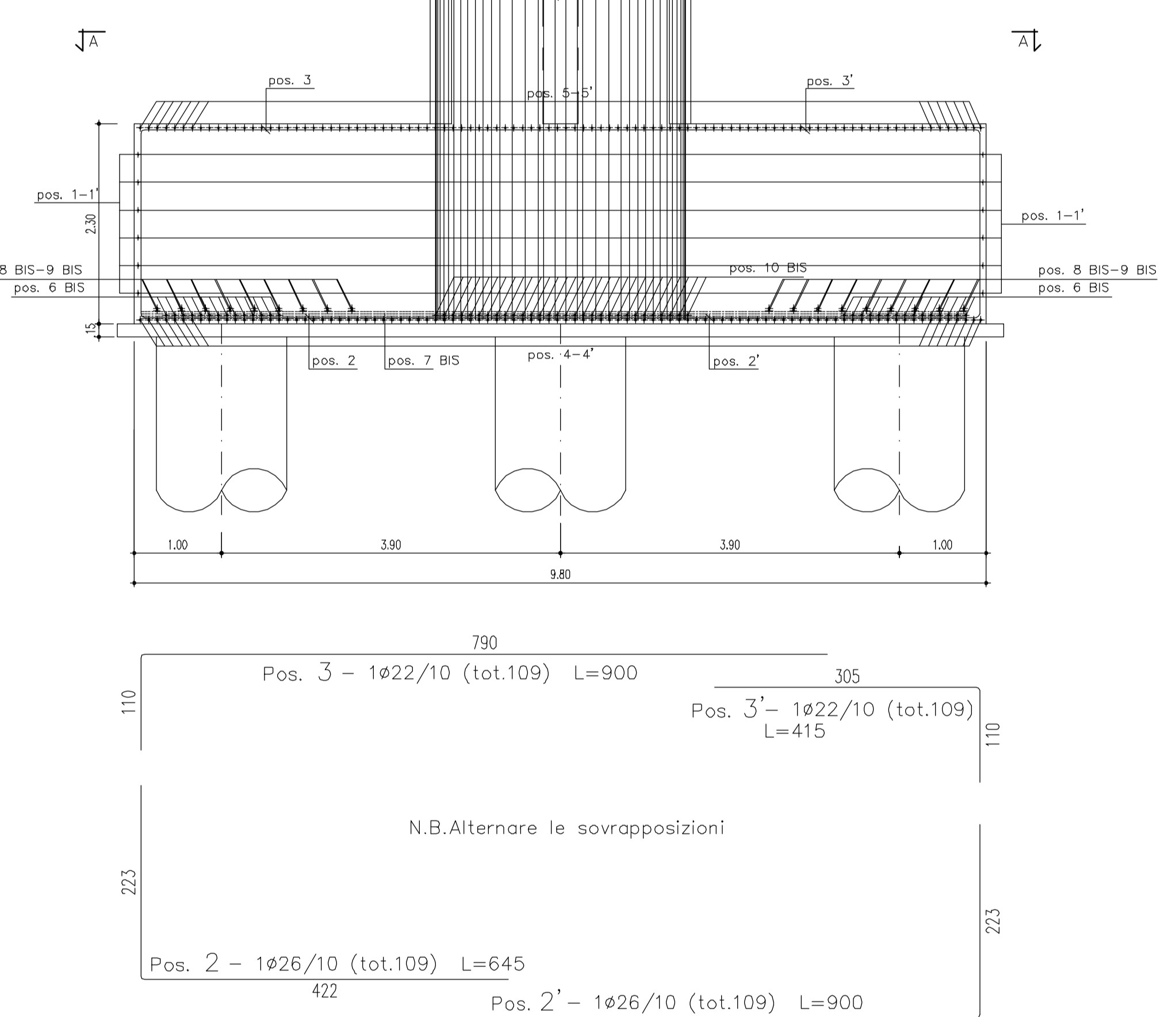

Armatura testa pali

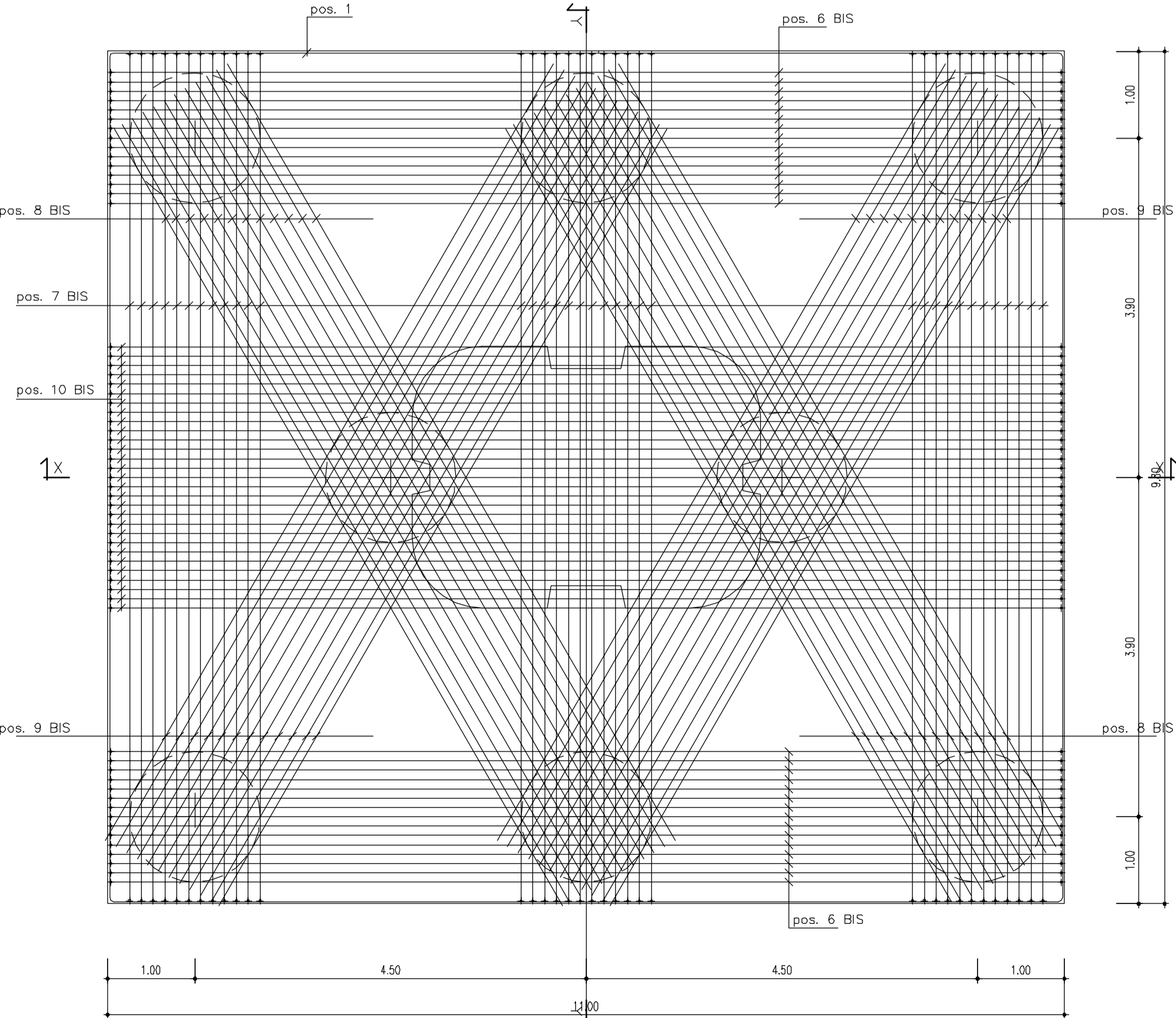

Sagoma	Pos.	φ (mm)	nb	A (cm)	B (cm)	L (m)	Ltot (m)
1	16	12	144	973	1700	144.00	144.00
1'	12	144	1000	12.00	144.00	144.00	144.00
2	26	109	233	422	6.45	703.00	703.00
2'	26	109	233	677	9.00	981.00	981.00
4	26	97	233	547	7.70	746.90	746.90
4'	26	97	233	677	9.00	873.00	873.00
5	22	109	110	790	9.00	981.00	981.00
5'	22	97	110	430	5.40	533.80	533.80
6	26	28	25	375	4.00	112.00	112.00
7	26	44	25	375	4.00	176.00	176.00
8	26	16	25	375	4.00	64.00	64.00
9	26	8	25	375	4.00	32.00	32.00
10	26	20	25	375	4.00	80.00	80.00
12	26	272	1000	12.00	3264.00	3264.00	3264.00
13	26	272	1000	12.00	3264.00	3264.00	3264.00
14	26	272	1000	12.00	3264.00	3264.00	3264.00
11	26	272	900	150	7.15	1944.8	1944.8
16	20	144			4.57	658.08	658.08

Spirale	Pos.	R (cm)	H (m)	np	φ (mm)	S (cm)	Ltot (m)	Note
1	15	70	35.00	8	12	20	6156.40	

φ (mm)	M/L (kg/m)	Ltot (m)	Mtot (kg)
16	1.578	288	454.46
20	2.466	658.08	1622.83
22	2.984	2830.15	8440.17
26	4.168	16688.75	61222.71
Tot.			71745.17

φ (mm)	M/L (kg/m)	Ltot (m)	Mtot (kg)
12	0.858	6156.40	5466.68

Massa totale acciaio : 77212.05 kg

Ultima posizione : 16

Armatura palo ø1500 L=38.00m

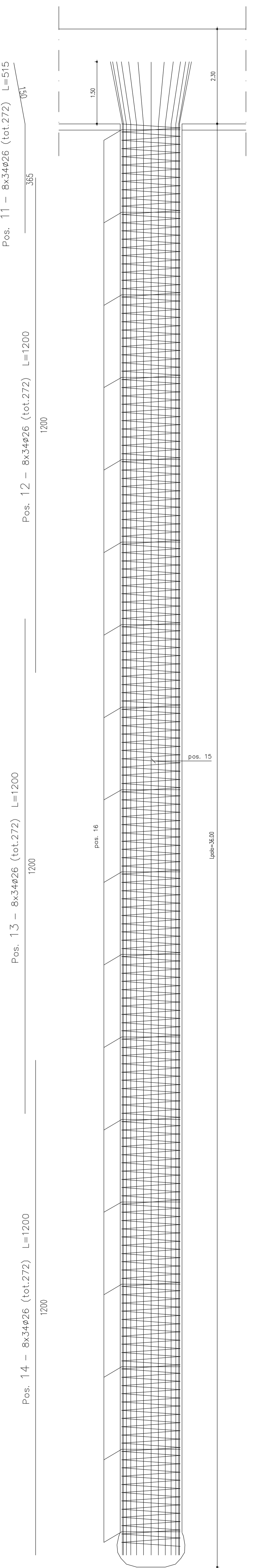

Sezione trasversale

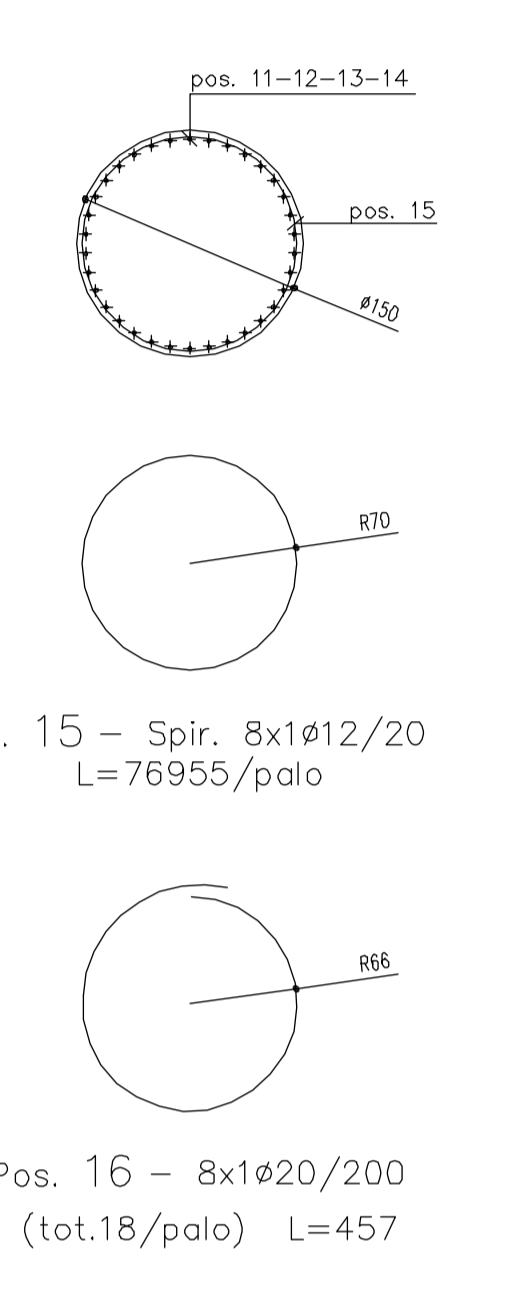

TRAVI PRINCIPALI E TRAVERSI	Quantità	Spessore	Spessore	Spessore
TRAVI PRINCIPALI	1	100	100	100
TRAVI TRAVERSI	1	100	100	100

CONGLOMERATO CEMENTIZIO	Quantità	Spessore	Spessore	Spessore
CONGLOMERATO CEMENTIZIO	1	100	100	100

ARMATURE PER C.A.	Quantità	Spessore	Spessore	Spessore
ARMATURE PER C.A.	1	100	100	100

ANAS S.p.A.
PA 12/09
CORRIDOIO PLURIMODALE TIRRENICO - NORD EUROPA
ITINERARIO AGRIGENTO - CALTANISSETTA - A19
S.S. N° 640 "DI PORTO EMPEDOCLE"
AMMODERNAMENTO E ADEGUAMENTO ALLA CAT. B DEL D.M. 5.11.2001
Dal km 44+000 allo svincolo con TA19

PROGETTO ESECUTIVO

Compagnia Generale: **Empedocle**

OPERE D'ARTE MAGGIORI
VIADOTTI

Viadotto Busta I
ARMATURA PILA 2 CARREGGIATA SX - FONDAZIONI

Codice Unico Progetto (CUP): F91B0900070001
Codice Elaborato: PA12_09-E | 149 | V | I | 20 | 6 | V | I | 0 | 6 | 9 | B | B | 0 | 4 | 4 | B | 150

REVISIONI:
A: 01/2011 EMISSIONE
B: 11/2011 Revisione a seguito di incontri con i committenti
C: 02/2011 EMISSIONE
D: 03/2011 EMISSIONE

PROGETTISTA: **EMPERO** VERBA
VERIFICATO: **VERBA**
AUTORIZZATO: **VERBA**