

ARMATURA PULVINO E BAGGIOLI PILA 3 SX TAV 2/2  
(SCALA 1 : 50)

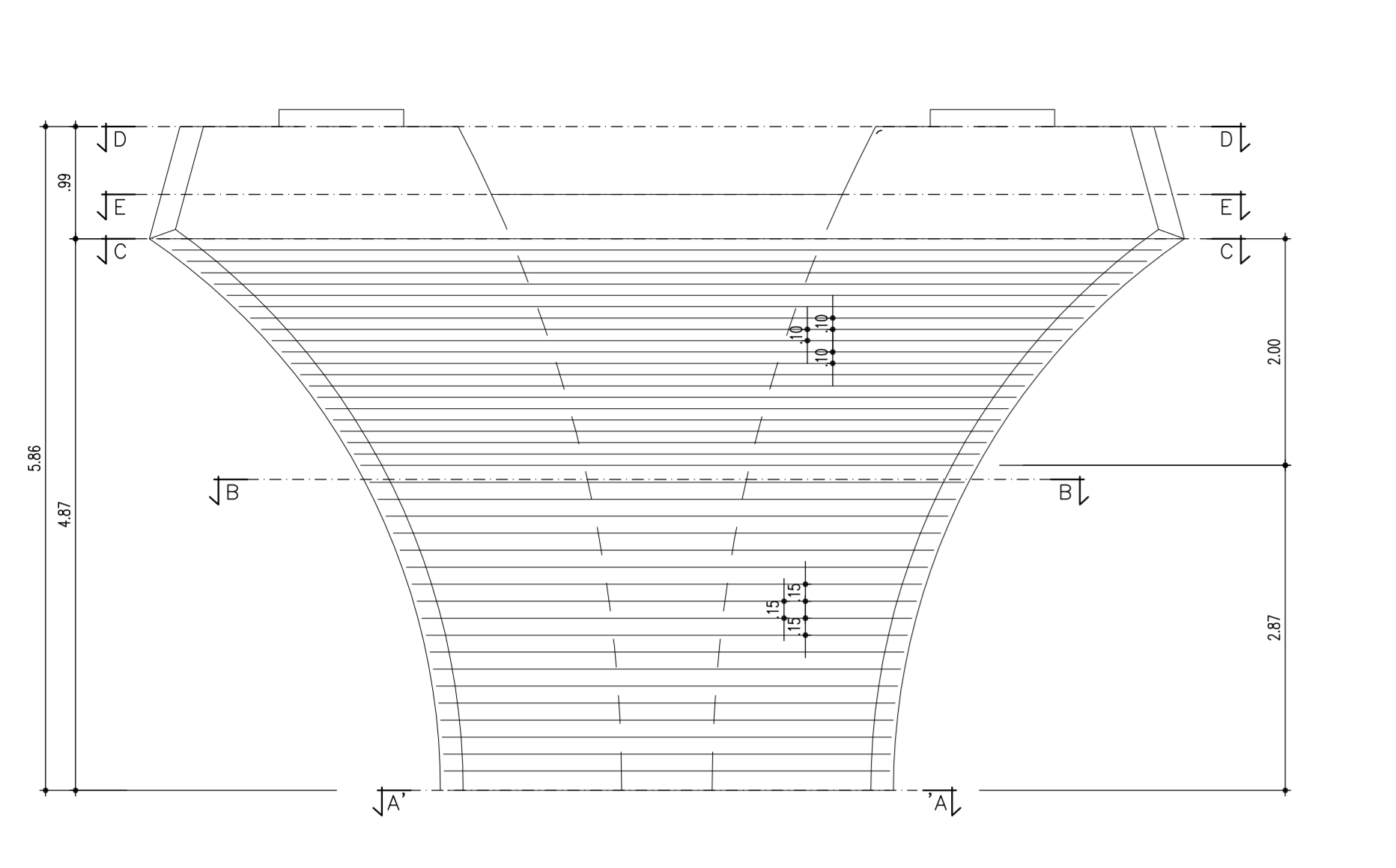

| Sagoma | Pos. | φ    | nb  | A    | B    | C    | D    | E    | L     | Ltot    |
|--------|------|------|-----|------|------|------|------|------|-------|---------|
|        |      | (mm) |     | (cm) | (cm) | (cm) | (cm) | (cm) | (cm)  | (m)     |
|        | 51   | 12   | 4   | 119  | 76   | 25   | 40   | 48   | 116   | 4.23    |
|        | 52   | 12   | 3   | 120  | 76   | 25   | 40   | 48   | 116   | 4.25    |
|        | 53   | 12   | 3   | 121  | 81   | 25   | 40   | 48   | 116   | 4.31    |
|        | 54   | 12   | 3   | 123  | 83   | 25   | 40   | 48   | 116   | 4.38    |
|        | 55   | 12   | 2   | 124  | 92   | 25   | 40   | 48   | 116   | 4.45    |
|        | 56   | 12   | 2   | 125  | 98   | 25   | 40   | 48   | 116   | 4.52    |
|        | 57   | 12   | 2   | 127  | 104  | 25   | 40   | 48   | 116   | 4.60    |
|        | 58   | 12   | 2   | 128  | 109  | 25   | 40   | 48   | 116   | 4.66    |
|        | 59   | 12   | 2   | 130  | 115  | 25   | 40   | 48   | 116   | 4.74    |
|        | 60   | 12   | 2   | 132  | 121  | 25   | 40   | 48   | 116   | 4.82    |
|        | 61   | 12   | 2   | 133  | 127  | 25   | 40   | 48   | 116   | 4.89    |
|        | 62   | 12   | 1   | 135  | 133  | 25   | 40   | 48   | 116   | 4.97    |
|        | 63   | 12   | 1   | 137  | 137  | 25   | 40   | 48   | 116   | 5.03    |
|        | 64   | 12   | 1   | 138  | 141  | 25   | 40   | 48   | 116   | 5.08    |
|        | 65   | 12   | 1   | 139  | 145  | 25   | 40   | 48   | 116   | 5.13    |
|        | 66   | 12   | 1   | 141  | 149  | 25   | 40   | 48   | 116   | 5.19    |
|        | 67   | 12   | 1   | 142  | 154  | 25   | 40   | 48   | 116   | 5.25    |
|        | 68   | 12   | 1   | 144  | 159  | 25   | 40   | 48   | 116   | 5.32    |
|        | 69   | 12   | 1   | 146  | 164  | 25   | 40   | 48   | 116   | 5.39    |
|        | 70   | 12   | 1   | 148  | 169  | 25   | 40   | 48   | 116   | 5.46    |
|        | 71   | 12   | 1   | 151  | 175  | 25   | 40   | 48   | 116   | 5.55    |
|        | 72   | 12   | 1   | 154  | 180  | 25   | 40   | 48   | 116   | 5.63    |
|        | 73   | 12   | 1   | 157  | 187  | 25   | 40   | 48   | 116   | 5.73    |
|        | 74   | 12   | 304 | 293  | 20   |      |      |      | 3.33  | 1012.32 |
|        | 74'  | 12   | 320 | 293  | 20   |      |      |      | 3.33  | 1056.60 |
|        | 75   | 12   | 85  | 285  | 20   |      |      |      | 2.83  | 285.00  |
|        | 75'  | 12   | 100 | 283  | 20   |      |      |      | 2.83  | 283.00  |
|        | 77   | 12   | 38  | 285  | 20   |      |      |      | 3.25  | 123.50  |
|        | 77'  | 12   | 40  | 285  | 20   |      |      |      | 3.25  | 130.00  |
|        | 78   | 12   | 38  | 285  | 20   |      |      |      | 3.05  | 115.90  |
|        | 78'  | 12   | 40  | 285  | 20   |      |      |      | 3.05  | 122.00  |
|        | 79   | 12   | 40  | 246  | 20   |      |      |      | 2.86  | 114.40  |
|        | 80   | 12   | 2   | 363  | 20   |      |      |      | 4.03  | 8.06    |
|        | 81   | 12   | 2   | 357  | 20   |      |      |      | 3.97  | 7.94    |
|        | 82   | 12   | 2   | 357  | 20   |      |      |      | 3.97  | 7.94    |
|        | 83   | 12   | 2   | 358  | 20   |      |      |      | 3.98  | 7.96    |
|        | 84   | 12   | 2   | 360  | 20   |      |      |      | 4.00  | 8.00    |
|        | 85   | 12   | 2   | 362  | 20   |      |      |      | 4.02  | 8.04    |
|        | 86   | 12   | 2   | 364  | 20   |      |      |      | 4.04  | 8.08    |
|        | 87   | 12   | 2   | 368  | 20   |      |      |      | 4.08  | 8.16    |
|        | 88   | 12   | 2   | 372  | 20   |      |      |      | 4.12  | 8.24    |
|        | 89   | 12   | 2   | 377  | 20   |      |      |      | 4.17  | 8.34    |
|        | 90   | 12   | 2   | 382  | 20   |      |      |      | 4.22  | 8.44    |
|        | 91   | 12   | 2   | 388  | 20   |      |      |      | 4.28  | 8.56    |
|        | 92   | 12   | 2   | 395  | 20   |      |      |      | 4.35  | 8.70    |
|        | 93   | 12   | 2   | 402  | 20   |      |      |      | 4.42  | 8.84    |
|        | 94   | 12   | 2   | 410  | 20   |      |      |      | 4.50  | 9.00    |
|        | 95   | 12   | 2   | 419  | 20   |      |      |      | 4.59  | 9.18    |
|        | 96   | 12   | 2   | 429  | 20   |      |      |      | 4.69  | 9.38    |
|        | 97   | 12   | 2   | 439  | 20   |      |      |      | 4.79  | 9.58    |
|        | 98   | 12   | 2   | 450  | 20   |      |      |      | 4.90  | 9.80    |
|        | 99   | 12   | 2   | 462  | 20   |      |      |      | 5.02  | 10.04   |
|        | 100  | 12   | 2   | 474  | 20   |      |      |      | 5.14  | 10.28   |
|        | 101  | 12   | 2   | 488  | 20   |      |      |      | 5.28  | 10.56   |
|        | 102  | 12   | 2   | 502  | 20   |      |      |      | 5.48  | 10.94   |
|        | 103  | 12   | 2   | 517  | 20   |      |      |      | 5.57  | 11.14   |
|        | 104  | 12   | 2   | 534  | 20   |      |      |      | 5.74  | 11.48   |
|        | 105  | 12   | 2   | 551  | 20   |      |      |      | 5.91  | 11.82   |
|        | 106  | 12   | 2   | 569  | 20   |      |      |      | 6.09  | 12.18   |
|        | 107  | 12   | 2   | 586  | 20   |      |      |      | 6.28  | 12.56   |
|        | 108  | 12   | 2   | 608  | 20   |      |      |      | 6.48  | 12.96   |
|        | 109  | 12   | 2   | 629  | 20   |      |      |      | 6.69  | 13.38   |
|        | 110  | 12   | 2   | 652  | 20   |      |      |      | 6.92  | 13.84   |
|        | 111  | 12   | 2   | 676  | 20   |      |      |      | 7.16  | 14.32   |
|        | 112  | 12   | 2   | 701  | 20   |      |      |      | 7.41  | 14.82   |
|        | 113  | 12   | 2   | 730  | 20   |      |      |      | 7.70  | 15.40   |
|        | 114  | 12   | 2   | 760  | 20   |      |      |      | 8.00  | 16.00   |
|        | 115  | 12   | 2   | 791  | 20   |      |      |      | 8.31  | 16.62   |
|        | 116  | 12   | 2   | 823  | 20   |      |      |      | 8.63  | 17.26   |
|        | 117  | 12   | 2   | 856  | 20   |      |      |      | 8.96  | 17.92   |
|        | 118  | 12   | 2   | 890  | 20   |      |      |      | 9.30  | 18.60   |
|        | 119  | 12   | 2   | 925  | 20   |      |      |      | 9.65  | 19.30   |
|        | 120  | 12   | 2   | 962  | 20   |      |      |      | 10.02 | 20.04   |
|        | 121  | 12   | 2   | 1000 | 20   |      |      |      | 10.40 | 20.80   |
|        | 122  | 12   | 2   | 1039 | 20   |      |      |      | 10.79 | 21.58   |
|        | 123  | 12   | 2   | 1080 | 20   |      |      |      | 11.19 | 22.38   |
|        | 124  | 12   | 2   | 1122 | 20   |      |      |      | 11.60 | 23.20   |
|        | 125  | 12   | 2   | 1166 | 20   |      |      |      | 12.02 | 24.04   |
|        | 126  | 12   | 2   | 1211 | 20   |      |      |      | 12.45 | 24.90   |
|        | 127  | 12   | 2   | 1258 | 20   |      |      |      | 12.89 | 25.78   |
|        | 128  | 12   | 2   | 1306 | 20   |      |      |      | 13.34 | 26.68   |
|        | 129  | 12   | 2   | 1356 | 20   |      |      |      | 13.80 | 27.60   |
|        | 130  | 12   | 2   | 1408 | 20   |      |      |      | 14.27 | 28.54   |
|        | 131  | 12   | 2   | 1461 | 20   |      |      |      | 14.75 | 29.50   |
|        | 132  | 12   | 2   | 1516 | 20   |      |      |      | 15.24 | 30.48   |
|        | 133  | 12   | 2   | 1573 | 20   |      |      |      | 15.74 | 31.48   |
|        | 134  | 12   | 2   | 1631 | 20   |      |      |      | 16.25 | 32.50   |
|        | 135  | 12   | 2   | 1691 | 20   |      |      |      | 16.77 | 33.54   |
|        | 136  | 12   | 2   | 1753 | 20   |      |      |      | 17.30 | 34.60   |
|        | 137  | 12   | 2   | 1816 | 20   |      |      |      | 17.84 | 35.68   |
|        | 138  | 12   | 2   | 1881 | 20   |      |      |      | 18.39 | 36.78   |
|        | 139  | 12   | 2   | 1948 | 20   |      |      |      | 18.95 | 37.90   |
|        | 140  | 12   | 2   | 2016 | 20   |      |      |      | 19.52 | 39.04   |
|        | 141  | 12   | 2   | 2086 | 20   |      |      |      | 20.10 | 40.20   |
|        | 142  | 12   | 2   | 2158 | 20   |      |      |      | 20.69 | 41.38   |
|        | 143  | 12   | 2   | 2231 | 20   |      |      |      | 21.29 | 42.58   |
|        | 144  | 12   | 2   | 2306 | 20   |      |      |      | 21.90 | 43.80   |
|        | 145  | 12   | 2   | 2383 | 20   |      |      |      | 22.52 | 45.04   |
|        | 146  | 12   | 2   | 2462 | 20   |      |      |      | 23.15 | 46.30   |
|        | 147  | 12   | 2   | 2543 | 20   |      |      |      | 23.79 | 47.58   |
|        | 148  | 12   | 2   | 2626 | 20   |      |      |      | 24.44 | 48.88   |
|        | 149  | 12   | 2   | 2711 | 20   |      |      |      | 25.10 | 50.20   |
|        | 150  | 12   | 2   | 2798 | 20   |      |      |      | 25.77 | 51.54   |
|        | 151  | 12   | 2   | 2887 | 20   |      |      |      | 26.45 | 52.90   |
|        | 152  | 12   | 2   | 2978 | 20   |      |      |      | 27.14 | 54.28   |
|        | 153  | 12   | 2   | 3071 | 20   |      |      |      | 27.84 | 55.68   |
|        | 154  | 12   | 2   | 3166 | 20   |      |      |      | 28.55 | 57.10   |
|        | 155  | 12   | 2   | 3263 | 20   |      |      |      | 29.27 | 58.54   |
|        | 156  | 12   | 2   | 3362 | 20   |      |      |      | 29.99 | 60.00   |
|        | 157  | 12   | 2   | 3463 | 20   |      |      |      | 30.72 | 61.48   |
|        | 158  | 12   | 2   | 3566 | 20   |      |      |      | 31.46 | 62.98   |
|        | 159  | 12   | 2   | 3671 | 20   |      |      |      | 32.21 | 64.50   |
|        | 160  | 12   | 2   | 3778 | 20   |      |      |      | 32.97 | 66.04   |
|        | 161  | 12   | 2   | 3887 | 20   |      |      |      | 33.74 | 67.60   |
|        | 162  | 12   | 2   | 3998 | 20   |      |      |      | 34.52 | 69.18   |
|        | 163  | 12   | 2   | 4111 | 20   |      |      |      | 35.31 | 70.78   |
|        | 164  | 12   | 2   | 4226 | 20   |      |      |      | 36.11 | 72.40   |
|        | 165  | 12   | 2   | 4343 | 20   |      |      |      | 36.92 | 74.04   |
|        | 166  | 12   | 2   | 4462 | 20   |      |      |      | 37.74 | 75.70   |
|        | 167  | 12   | 2   | 4583 | 20   |      |      |      | 38.57 | 77.38   |
|        | 168  | 12   | 2   | 4706 | 20   |      |      |      | 39.41 | 79.08   |
|        | 169  | 12   | 2   | 4831 | 20   |      |      |      | 40.26 | 80.80   |
|        | 170  | 12   | 2   | 4958 | 20   |      |      |      | 41.12 | 82.54   |
|        | 171  | 12   | 2   | 5087 | 20   |      |      |      | 41.99 | 84.30   |
|        | 172  | 12   | 2   | 5218 | 20   |      |      |      | 42.87 | 86.08   |
|        | 173  | 12   | 2   | 5351 | 20   |      |      |      | 43.76 | 87.88   |
|        | 174  | 12   | 2   | 5486 | 20   |      |      |      | 44.66 | 89.70   |
|        | 175  | 12   | 2   | 5623 | 20   |      |      |      | 45.57 | 91.54   |
|        | 176  | 12   | 2   | 5762 | 20   |      |      |      | 46.49 | 93.40   |
|        | 177  | 12   | 2   | 5903 | 20   |      |      |      | 47.42 | 95.28   |
|        | 178  | 12   | 2   | 6046 | 20   |      |      |      | 48.36 | 97.18   |
|        | 179  | 12   | 3   | 355  | 20   |      |      |      | 3.95  | 11.85   |
|        | 180  | 12   | 3   | 355  | 20   |      |      |      | 3.95  | 11.85   |
|        | 181  | 12   | 3   | 355  | 20   |      |      |      | 3.95  | 11.85   |
|        | 182  | 12   | 3   | 356  | 20   |      |      |      | 3.96  | 11.88   |
|        | 183  | 12   | 3   | 358  | 20   |      |      |      | 3.98  | 11.94   |
|        | 184  | 12   | 3   | 360  | 20   |      |      |      | 4.00  | 12.00   |
|        | 185  | 12   | 3   | 363  | 20   |      |      |      | 4.03  | 12.09   |
|        | 186  | 12   | 3   | 366  | 20   |      |      |      | 4.06  | 12.18   |
|        | 187  | 12   | 3   | 370  | 20   |      |      |      | 4.10  | 12.30   |
|        | 188  | 12   | 3   | 375  | 20   |      |      |      | 4.15  | 12.45   |
|        | 189  | 12   | 3   | 381  | 20   |      |      |      | 4.21  | 12.63   |

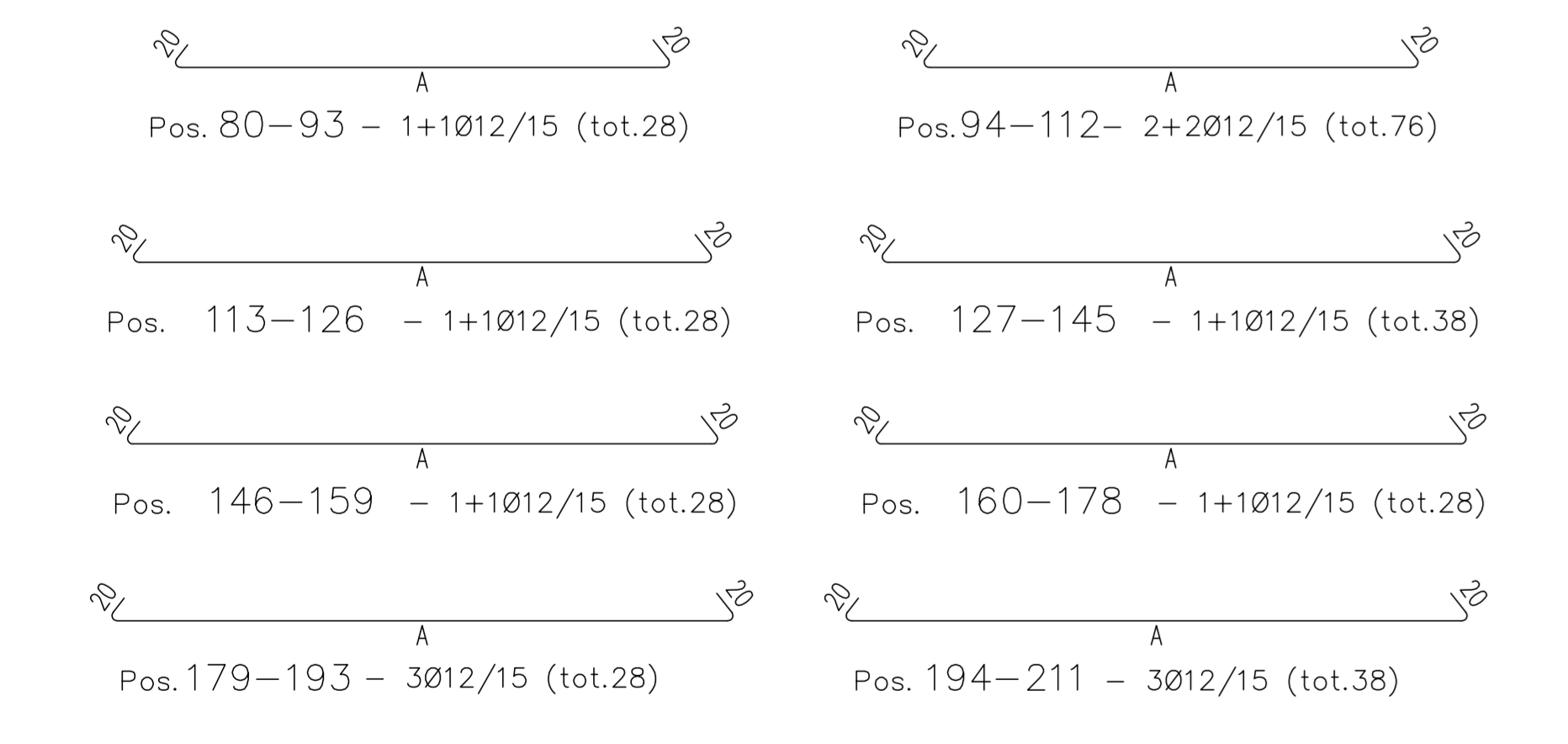
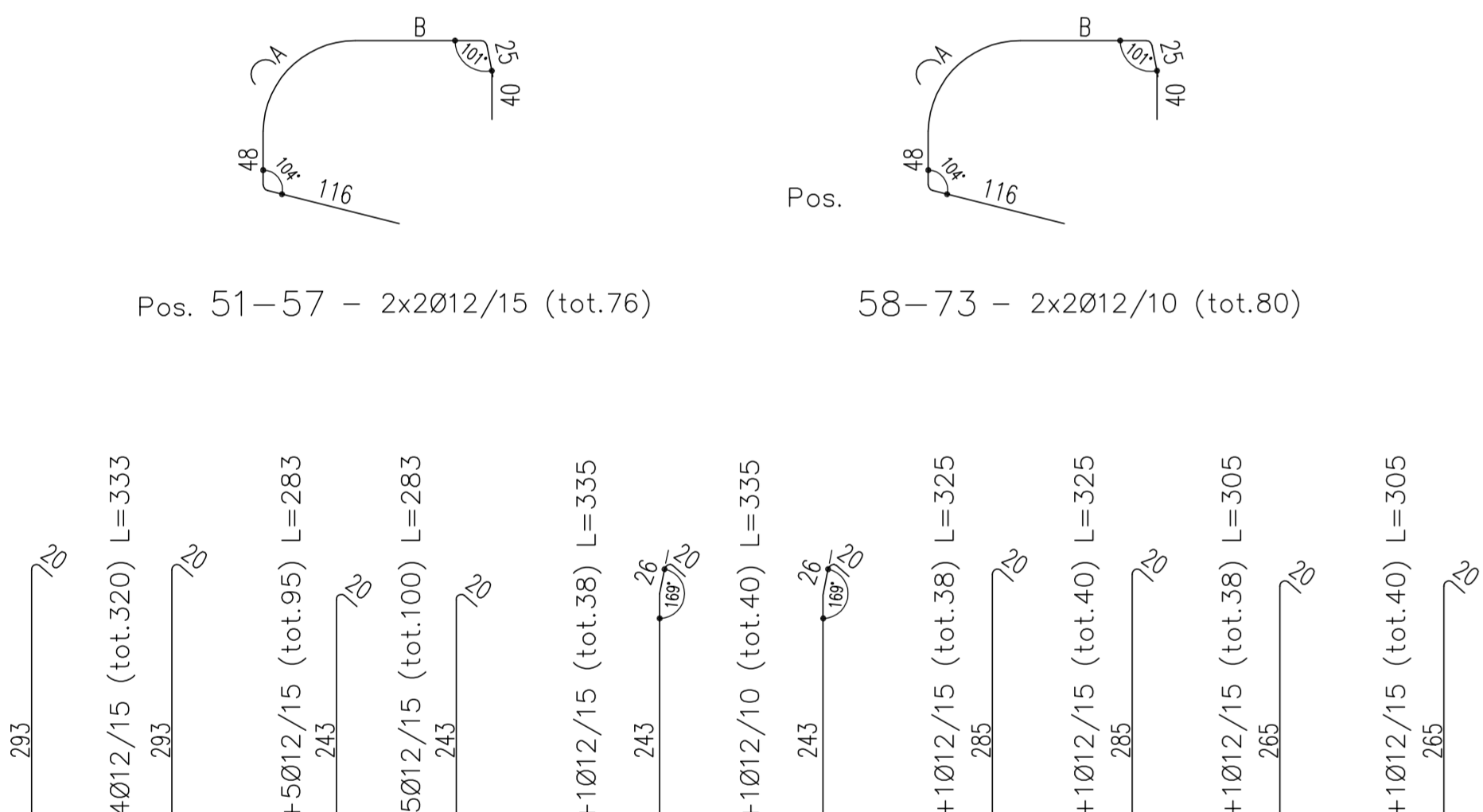
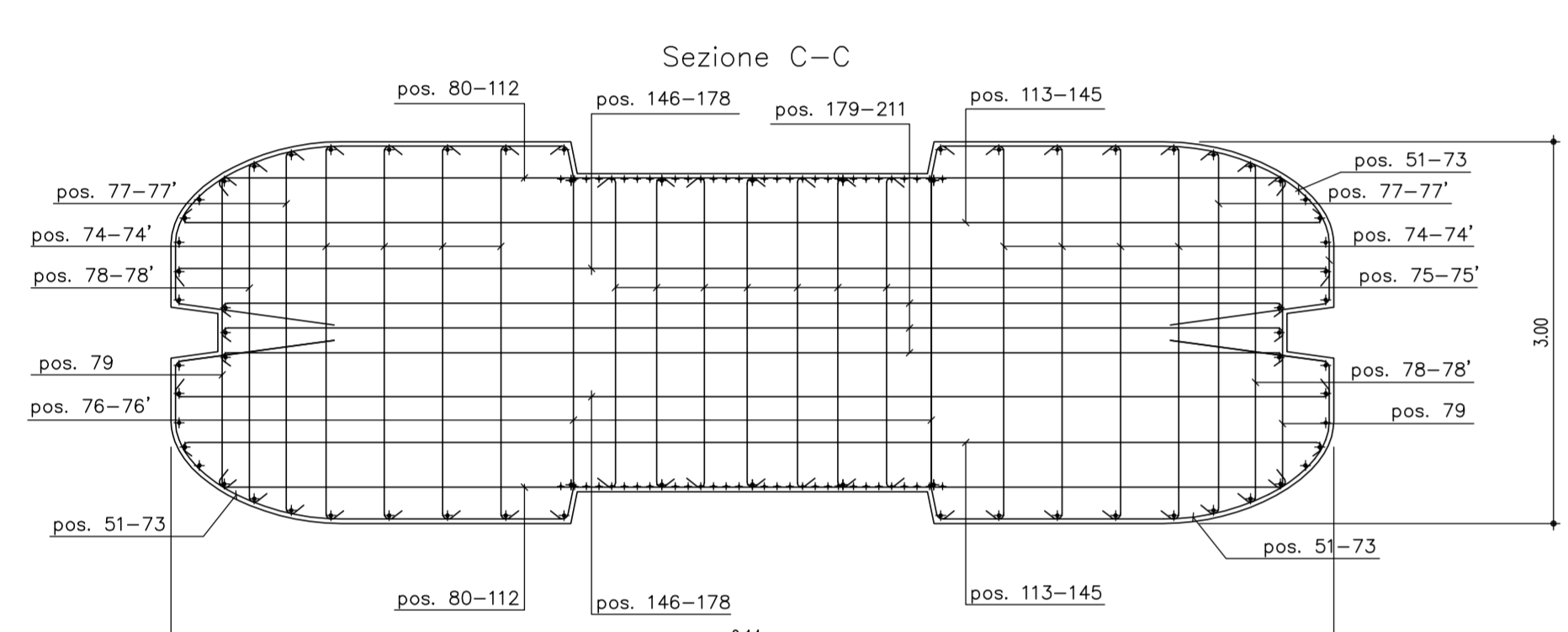
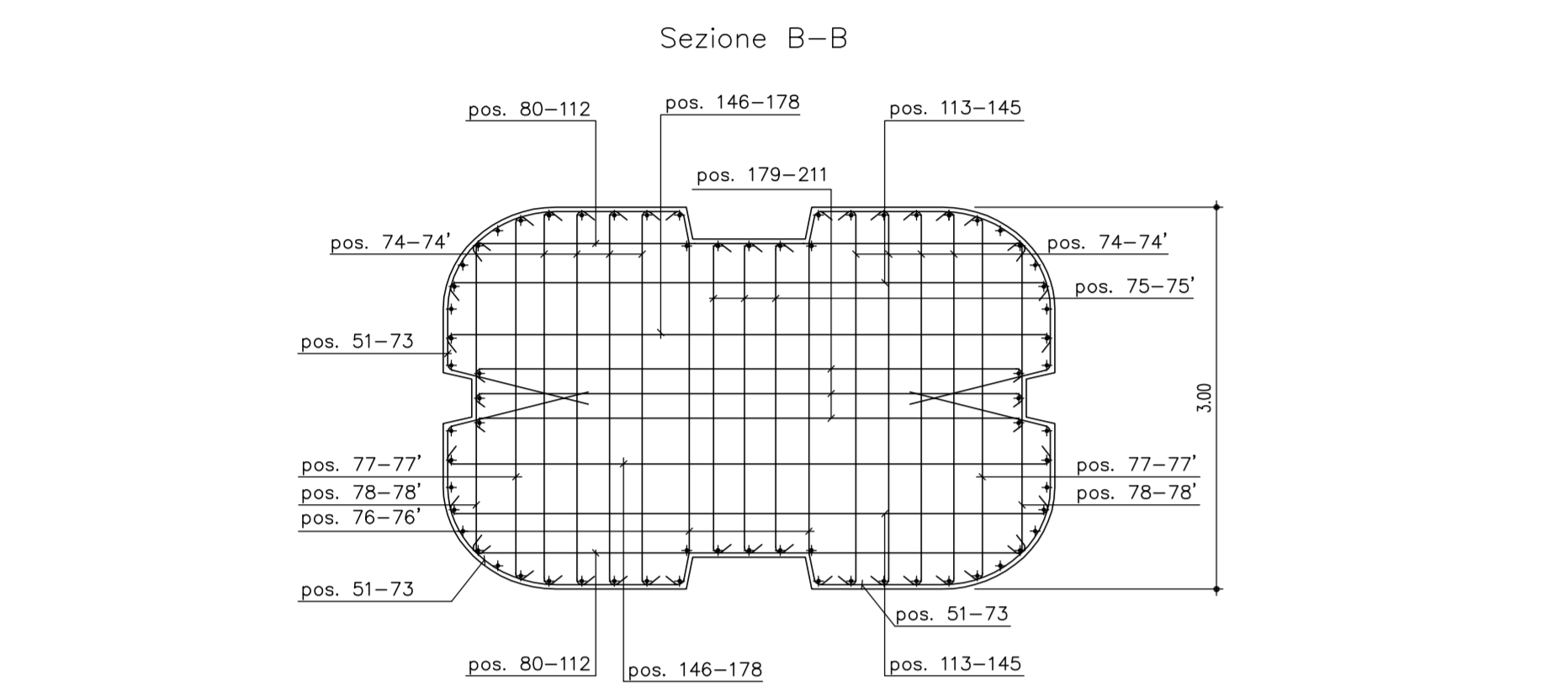

| Sagoma | Pos. | φ    | nb | A    | B    | C    | D    | E    | L    | Ltot  |
|--------|------|------|----|------|------|------|------|------|------|-------|
|        |      | (mm) |    | (cm) | (cm) | (cm) | (cm) | (cm) | (cm) | (m)   |
|        | 190  | 12   | 3  | 387  | 20   |      |      |      | 4.23 | 12.81 |
|        | 191  | 12   | 3  | 393  | 20   |      |      |      | 4.23 | 12.99 |
|        | 192  | 12   | 3  | 401  | 20   |      |      |      | 4.41 | 13.23 |
|        | 193  | 12   | 3  | 409  | 20   |      |      |      | 4.49 | 13.47 |
|        | 194  | 12   | 3  | 417  | 20   |      |      |      | 4.57 | 13.71 |
|        | 195  | 12   | 3  | 427  | 20   |      |      |      | 4.67 | 14.01 |
|        | 196  | 12   | 3  | 437  | 20   |      |      |      | 4.77 | 14.31 |