

PIANTA
Scala 1:200

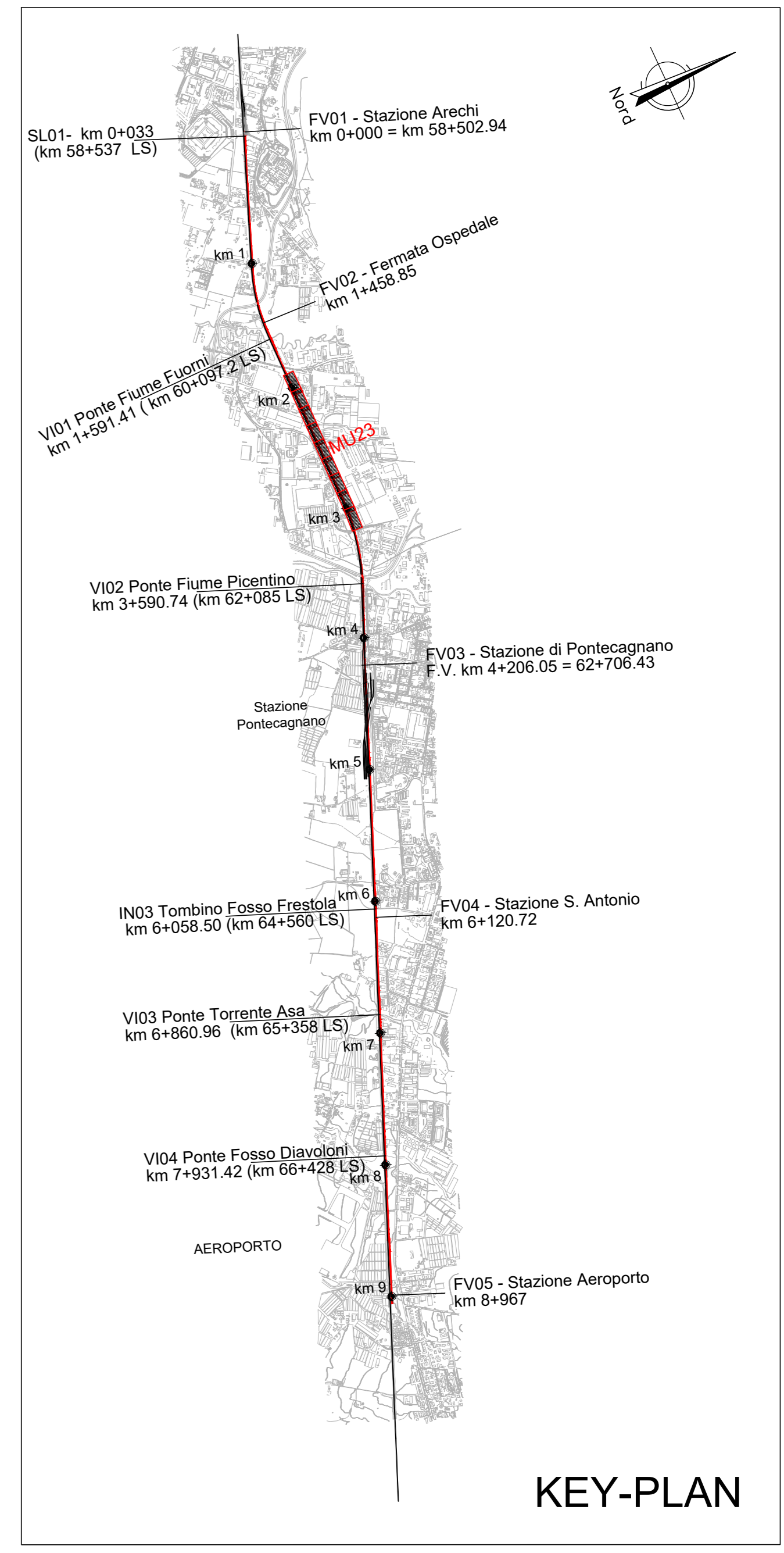
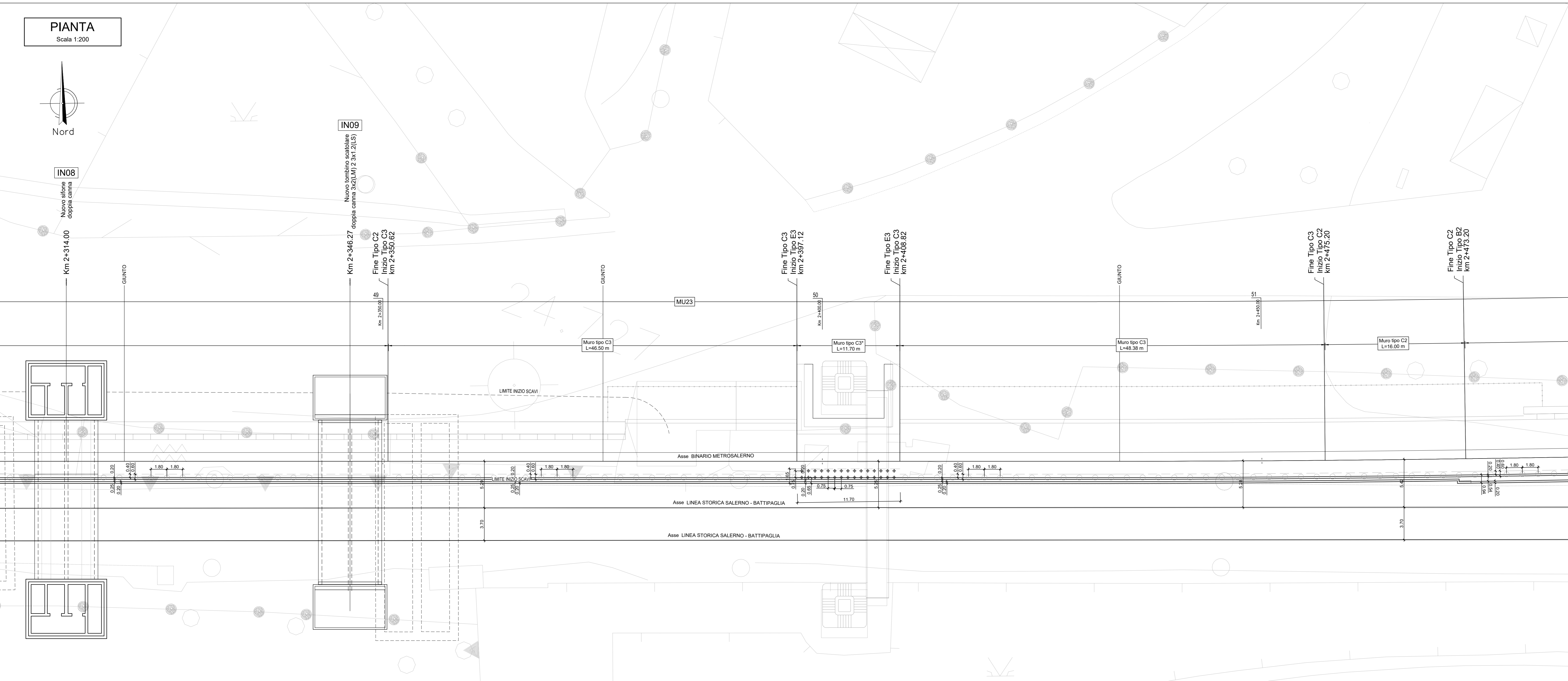
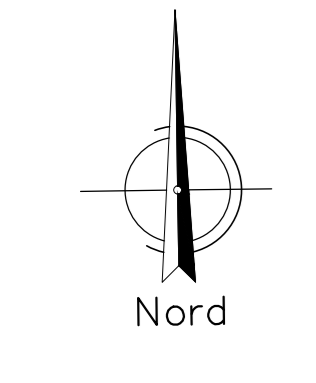

KEY-PLAN

Per tabella materiali e incidenza armature vedi elab. NN1X.0.0.D.78.CM.00.06.0.0.001

PROSPETTO
Scala 1:200

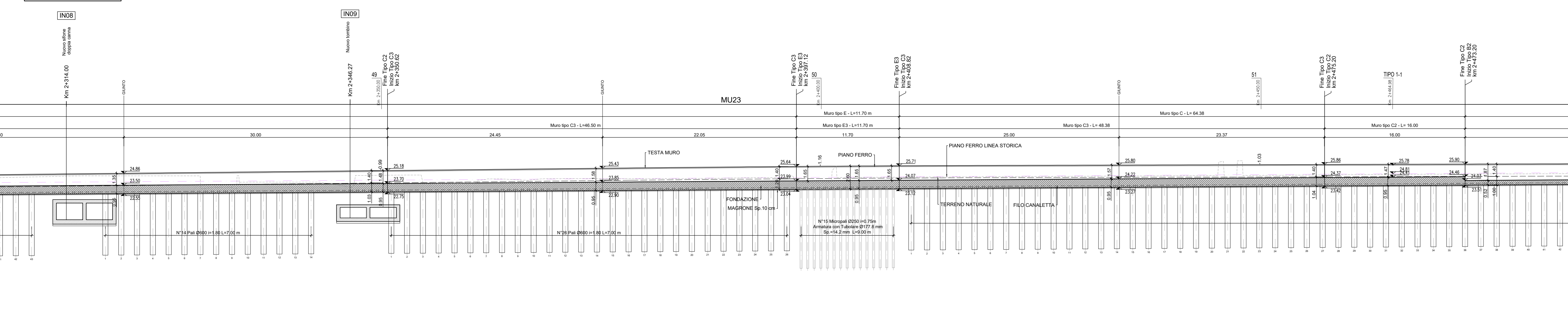

MU23

TIPO MURO	INIZIO PROG.	FINE PROG.	H1 - Min.	H1 - Max.	H2 - Min.	H2 - Max.	Htotal - Min.	Htotal - Max.
C1	km 1+896.16	km 2+233.32	0,36m	1,00m	-	-	1,31m	1,95m
C2	km 2+233.32	km 2+350.62	1,40m	1,40m	0,54m	1,03m	1,94m	2,43m
C3	km 2+350.62	km 2+397.12	1,40m	1,40m	1,03m	1,20m	2,43m	2,60m
E3	km 2+397.12	km 2+408.82	1,40m	1,40m	1,20m	1,20m	2,60m	2,60m
C3	km 2+408.82	km 2+475.20	1,40m	1,40m	1,04m	1,20m	2,44m	2,60m
C2	km 2+475.20	km 2+473.20	1,40m	1,40m	1,00m	1,04m	2,40m	2,44m
B2	km 2+473.20	km 2+551.66	1,40m	1,40m	0,73m	1,00m	2,13m	2,40m
A2	km 2+551.66	km 2+613.06	1,44m	1,60m	-	-	1,96m	2,12m
A1	km 2+613.06	km 2+957.48	0,97m	1,44m	-	-	1,49m	1,96m
B1	km 2+957.48	km 3+083.15	0,97m	1,02m	-	-	1,49m	1,54m
C1	km 3+083.15	km 3+170.20	0,48m	0,60m	-	-	1,43m	1,55m

MURI DI INTERBINARIO "TIPO C3"
SEZIONE 51 prop. 2+450.00
Scala 1:100

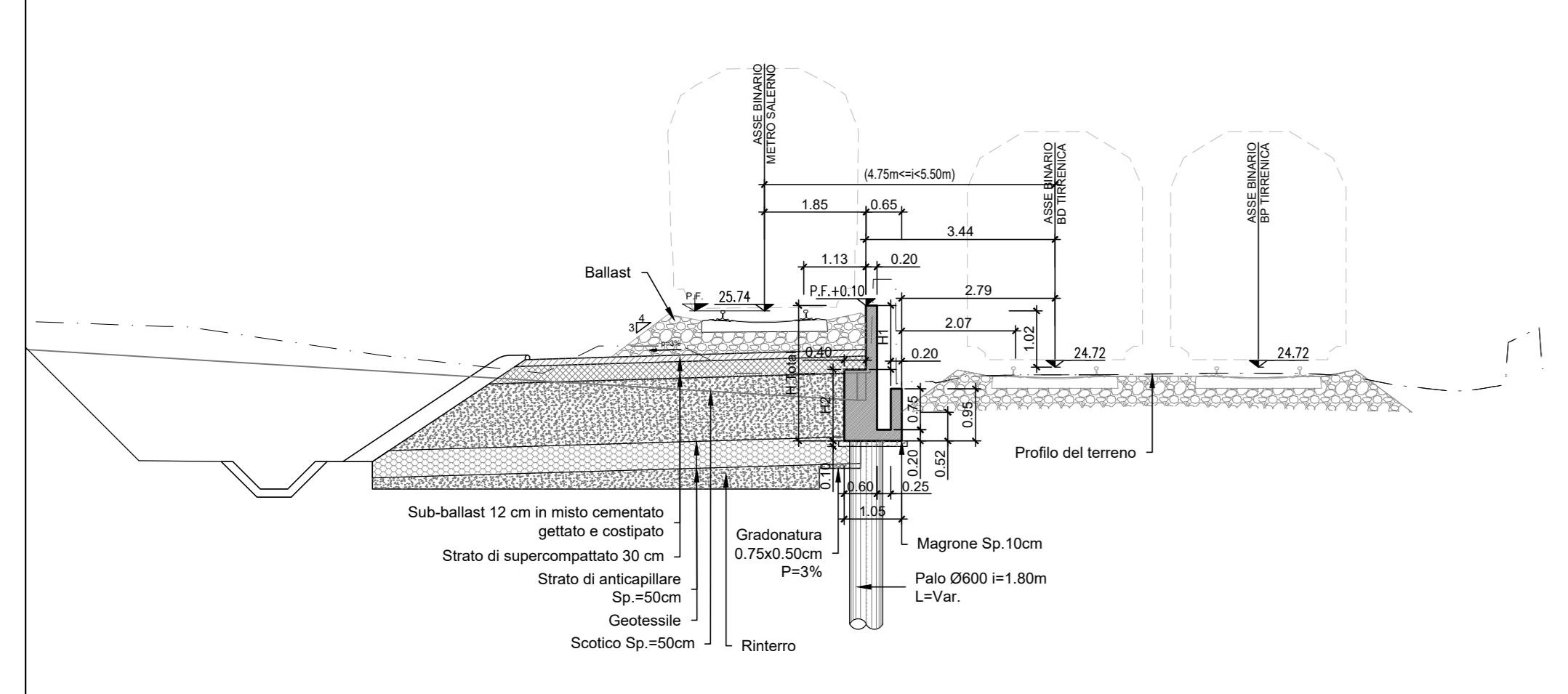

MURI DI INTERBINARIO "TIPO E3"
SEZIONE 50 prop. 2+400.00
Scala 1:100

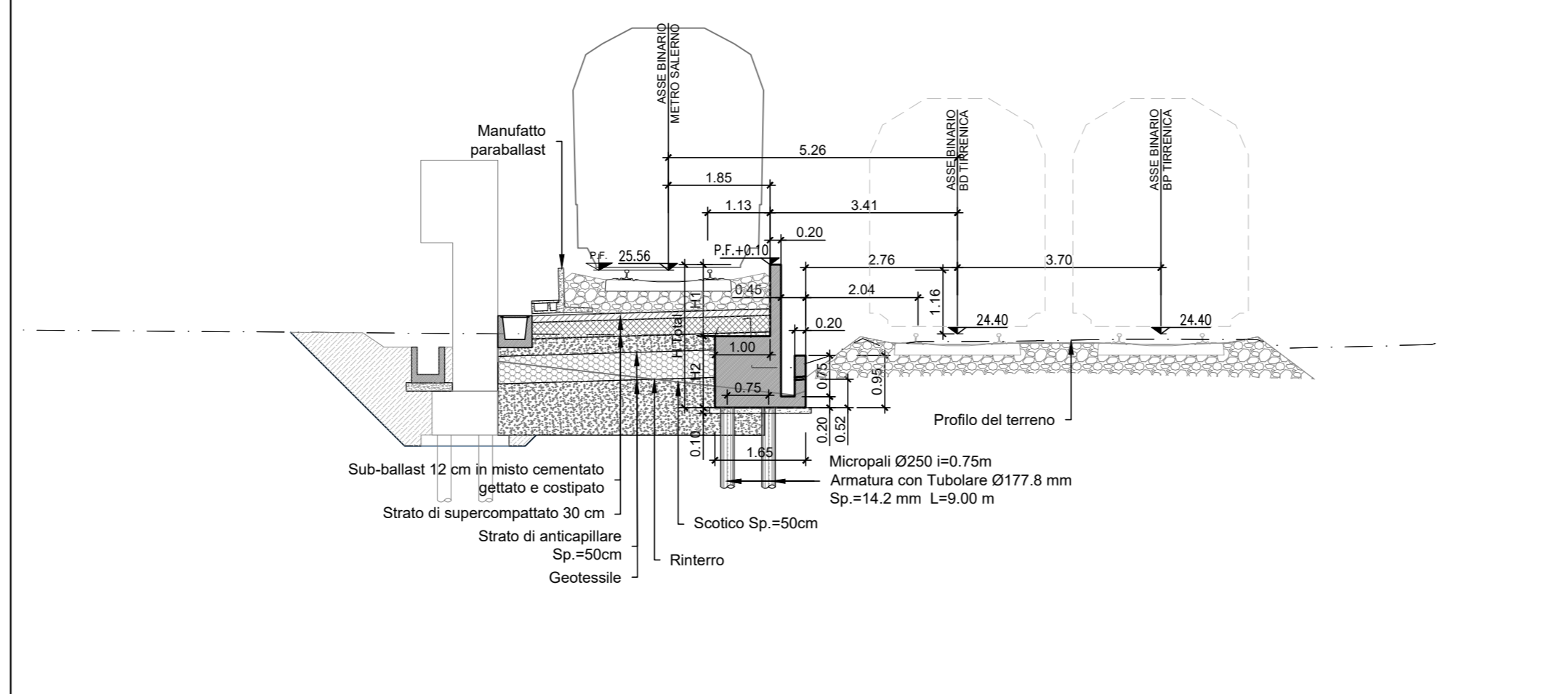

MURI DI INTERBINARIO "TIPO C2"
SEZIONE 48 prop. 2+300.00
Scala 1:100

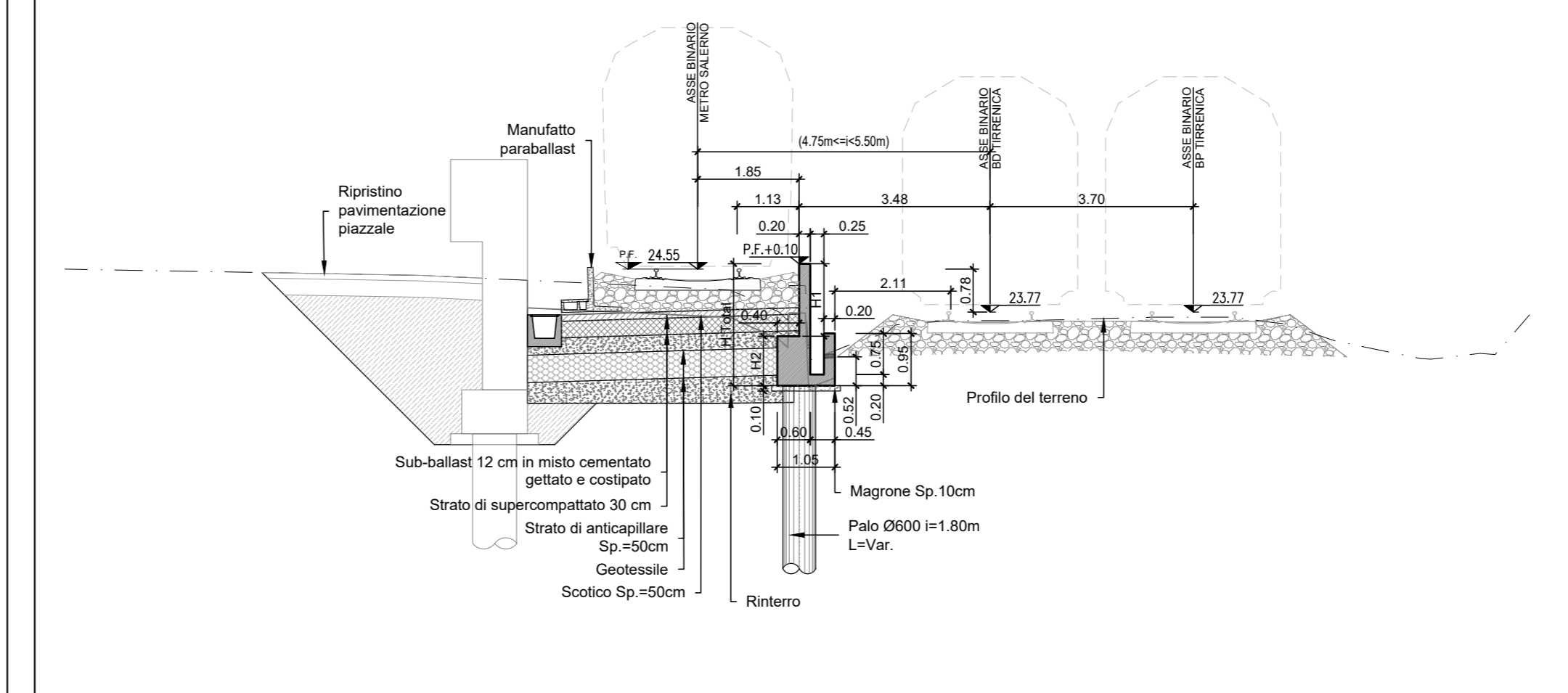

COMMITTENTE: **RFI** RETE FERROVIARIA ITALIANA GRUPPO FERROVIE DELLO STATO ITALIANE

PROGETTAZIONE: **ITALFER** GRUPPO FERROVIE DELLO STATO ITALIANE

U.O. INFRASTRUTTURE SUD

PROGETTO DEFINITIVO

LINEA SALERNO - PONTECAGNANO AEROPORTO
COMPLETAMENTO METROPOLITANA DI SALERNO
TRATTA ARECHI - PONTECAGNANO AEROPORTO
MURI DI INTERBINARIO
MU23 Muro di interbinario dal Km 1+896.09 al Km 3+170.12
Plano-profilo di progetto tav 4 di 9

SCALA: 1:200

Rev.	Descrizione	Redatto	Data	Verificato	Data	Approvato	Data	Autorizzato Data
A	Emissione Esecutiva	F. Scattolon	Set-2020	G. Romano	Set-2020	M. Di Biase	Set-2020	Gen-2021
B	Emissione Esecutiva	F. Scattolon	Set-2020	G. Romano	Set-2020	M. Di Biase	Set-2020	Gen-2021
C	Emissione Esecutiva	F. Scattolon	Gen-2021	G. Romano	Gen-2021	M. Di Biase	Gen-2021	Gen-2021

COMMESSA LOTTO FASE ENTE TIPO DOC. OPERA/DISCIPLINA PROGR. REV.

NN1X 00 D 78 P 9 MU2300 004 C

n. Elab.: _____