

PIANTA

Scala 1:200

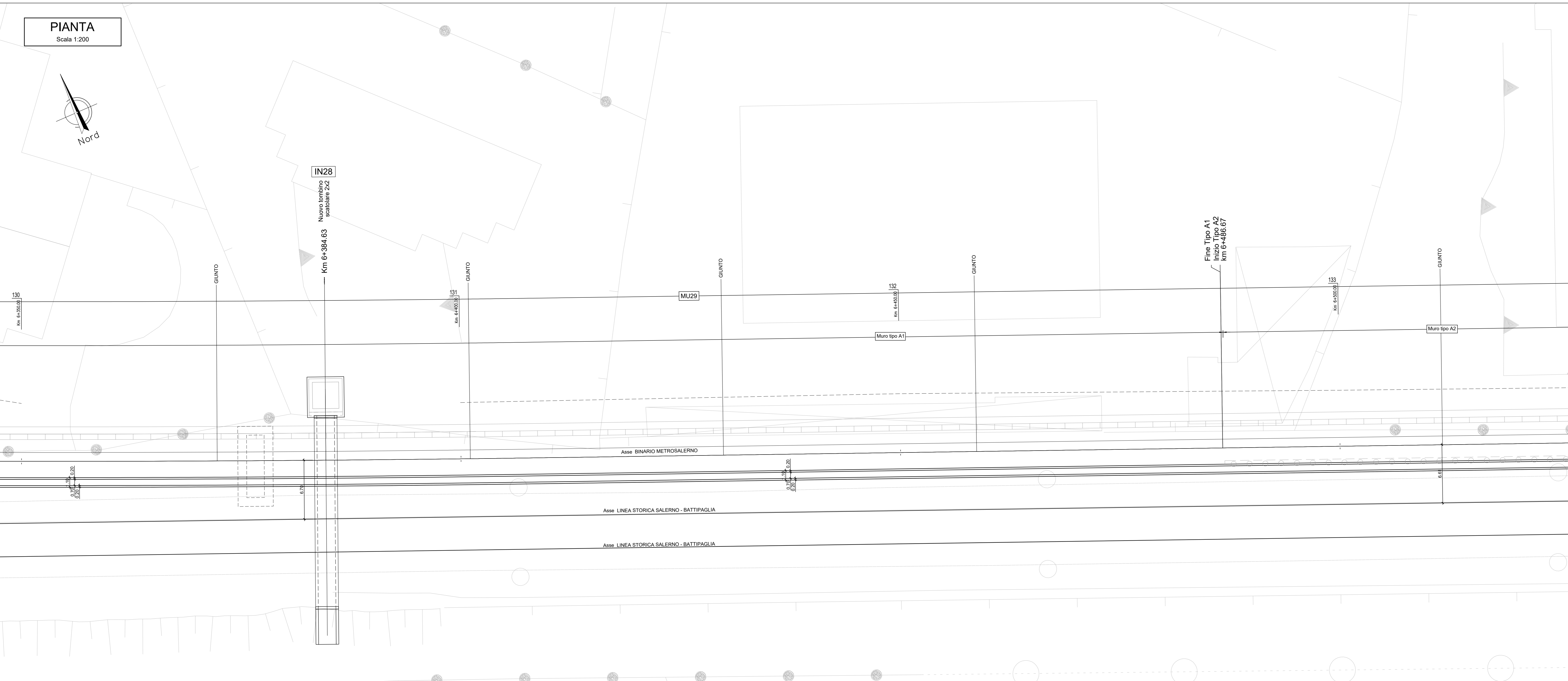
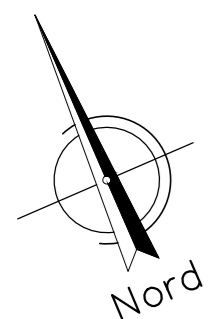

PROSPETTO

Scala 1:200

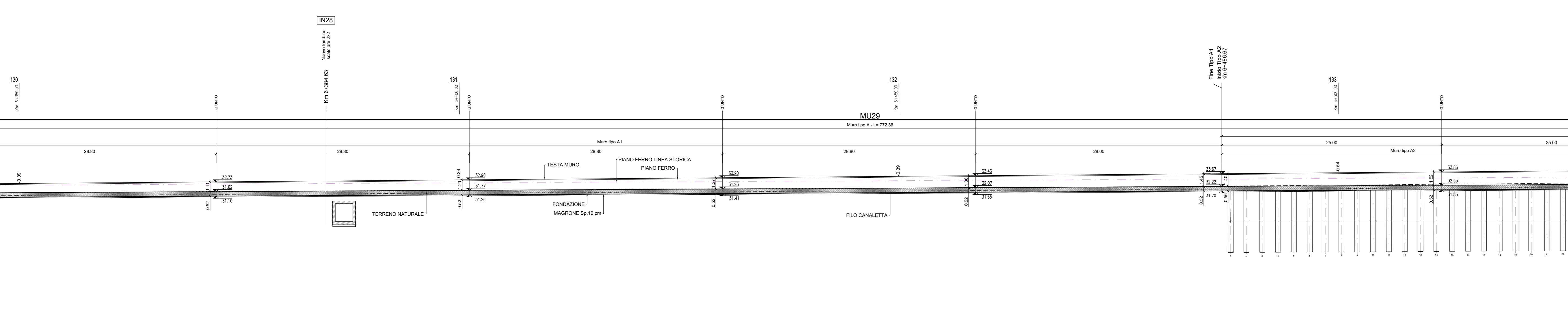

MURI DI INTERBINARIO "TIPO A1"

SEZIONE 130 prog. 6+350.00

Scala 1:100

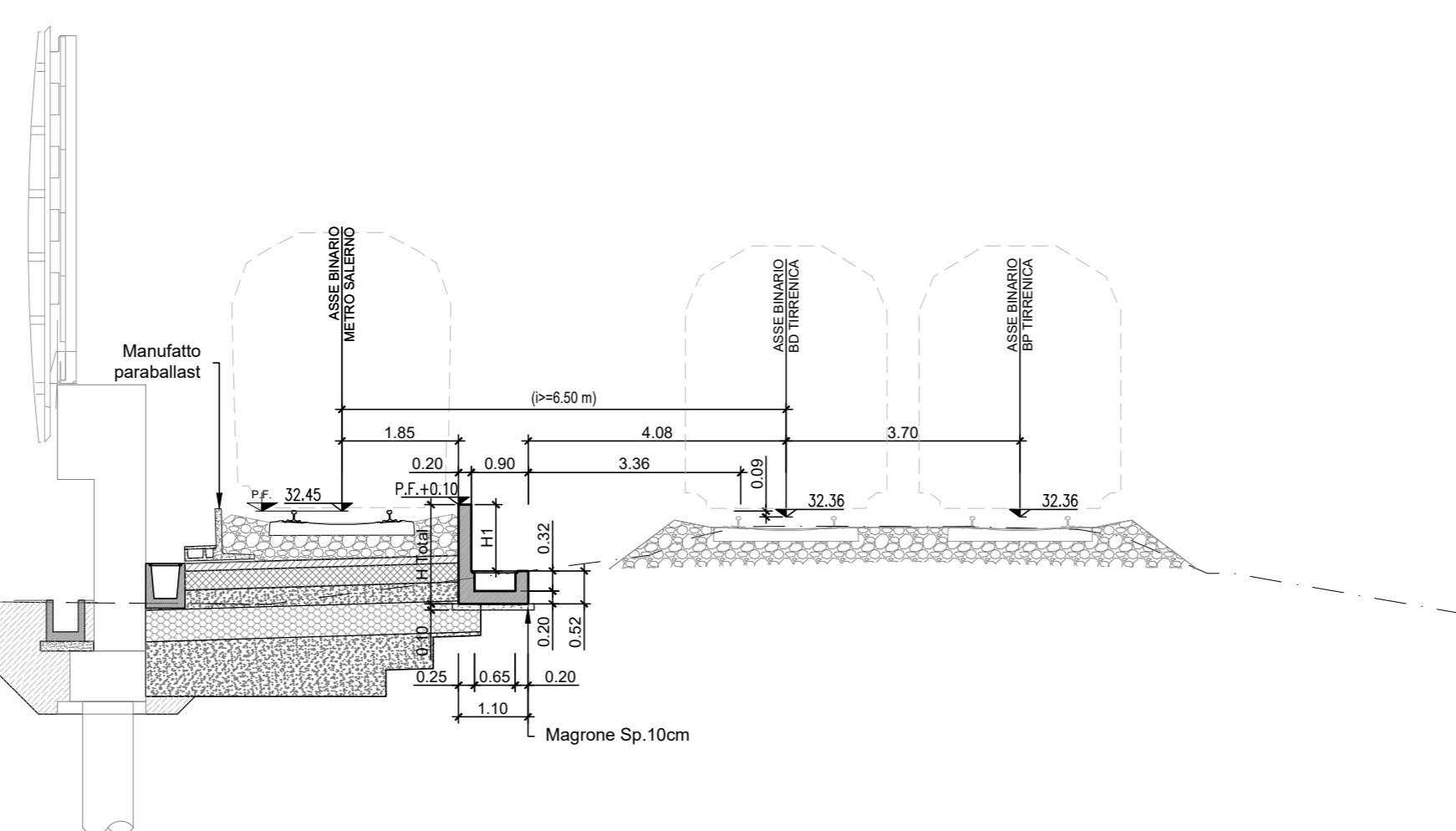

MURI DI INTERBINARIO "TIPO A2"

SEZIONE 133 prog. 6+500.00

Scala 1:100

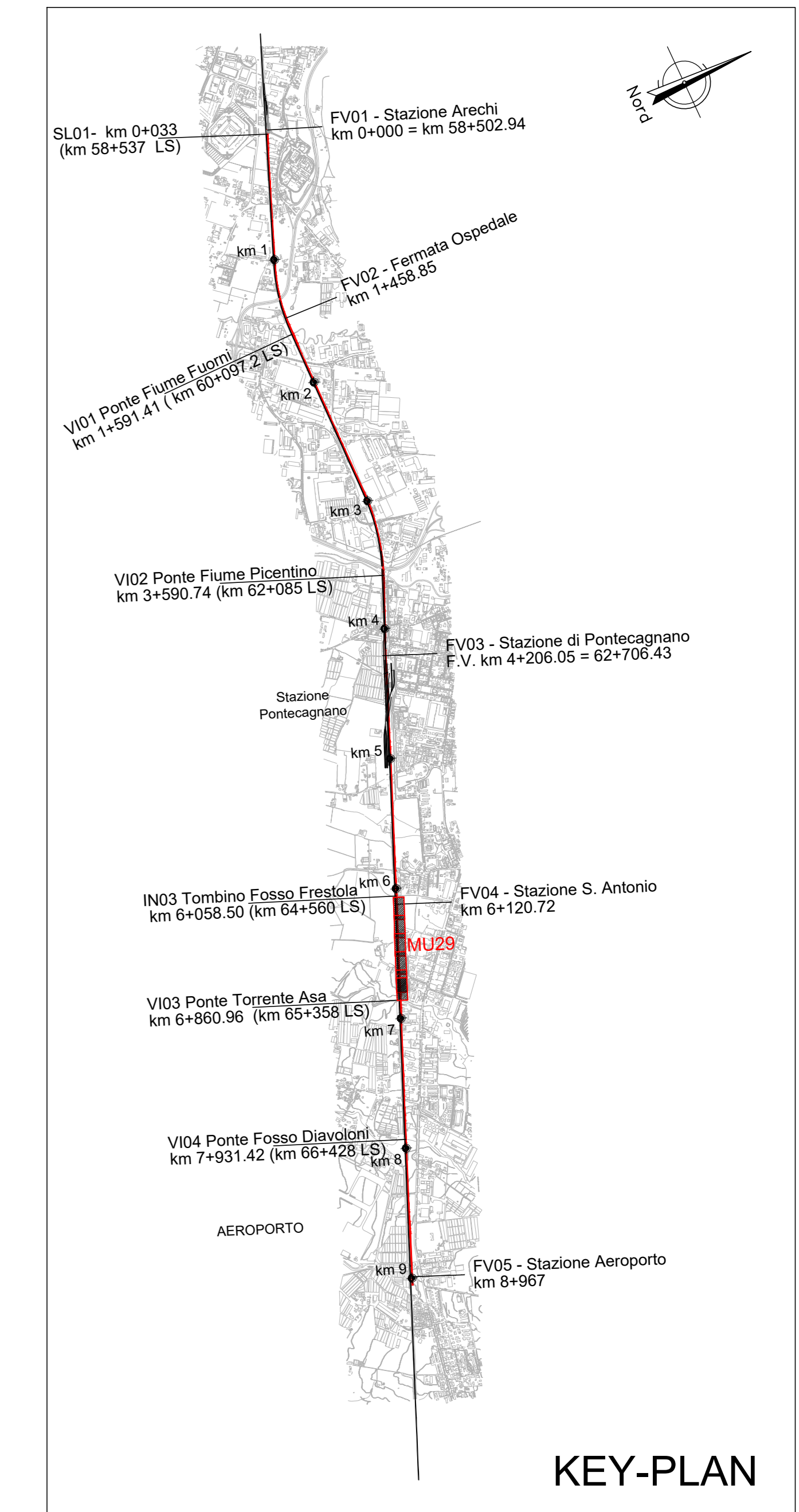
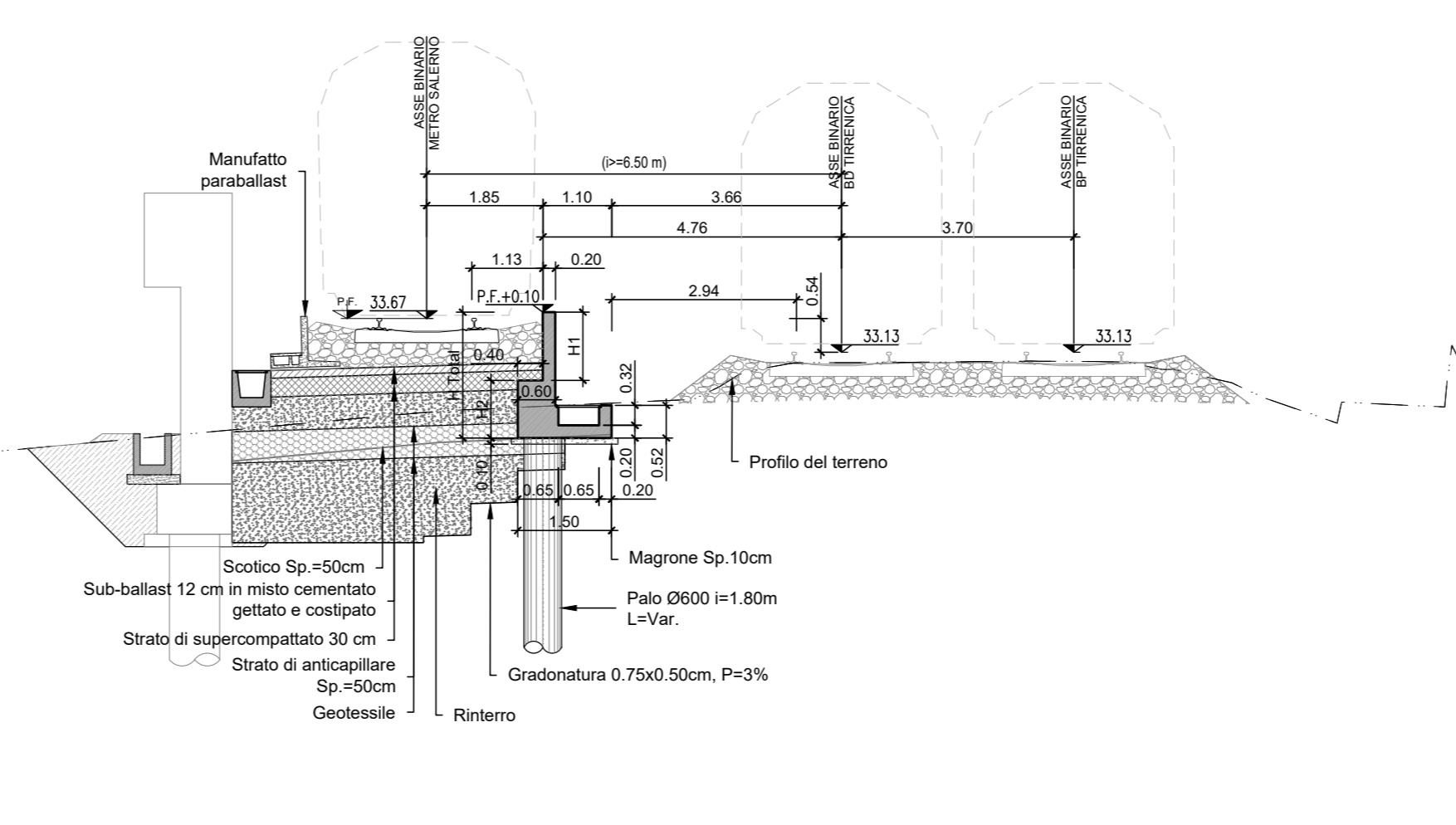

KEY-PLAN

Per tabella materiali e incidenza armature vedi elab. NN1X.0.0.D.78.CM.00.06.0.0.001

MU29

TIPO MURO	INIZIO PROG.	FINE PROG.	H1 - Min.	H1 - Max.	H2 - Min.	H2 - Max.	Htotal - Min.	Htotal - Max.
A2	km 6+060.48	km 6+140.70	1,40m	1,40m	0,64m	1,02m	2,04m	2,42m
A1	km 6+140.70	km 6+486.67	0,88m	1,52m	-	-	1,40m	2,04m
A2	km 6+486.67	km 6+699.11	1,40m	1,40m	0,56m	0,56m	1,96m	1,96m
A1	km 6+699.11	km 6+832.85	1,08m	1,45m	-	-	1,60m	1,97m

COMMITTENTE:

PROGETTAZIONE:

U.O. INFRASTRUTTURE SUD
PROGETTO DEFINITIVO
LINEA SALERNO - PONTECAGNANO AEROPORTO
COMPLETAMENTO METROPOLITANA DI SALERNO
TRATTA ARECHI - PONTECAGNANO AEROPORTO
 MURI DI INTERBINARIO
 MU29 Muro di interbinario dal Km 6+062.15 al Km 6+832.71
 Piano-profilo di progetto tav 3 di 6

SCALA:
1:200

Rev.	Descrizione	Redatto	Data	Verificato	Data	Approvato	Data	Autorizzato Data
A	Emissione Esecutiva	[Firma]	Set-2020	G. Romano	Set-2020	M. Di Stefano	Set-2020	01/04/2021
B	Emissione Esecutiva	[Firma]	08-2020	G. Romano	08-2020	M. Di Stefano	08-2020	08/2021
C	Emissione Esecutiva	[Firma]	Gen-2021	G. Romano	Gen-2021	M. Di Stefano	Gen-2021	01/04/2021

COMMESSA LOTTO FASE ENTE TIPO DOC. OPERA/DISCIPLINA Progr. REV.
 NN1X 00 D 78 P9 MU2900 003 C

nn1x.0.0.d.78.p9.mu.29.0.0.003.c n. Elab.: