

TRAVE "TIPO A" L=63.1+63.85m scala (1:20)

TRAVE "TIPO B" L=61.87+62.69m scala (1:20)

TRAVE "TIPO C" L=61.85m scala (1:20)

TRAVE "TIPO D" L=30.30m scala (1:20)

TRAVE "TIPO E" L=31.80m scala (1:20)

TIPOLOGIA CONCII

A	B	C	D
Bs	300	300	300
h	50	50	50
Tw	800	800	800
Bs	200	200	200
h	50	50	50
Tw	600	600	600
Bs	100	100	100
h	50	50	50
Tw	400	400	400

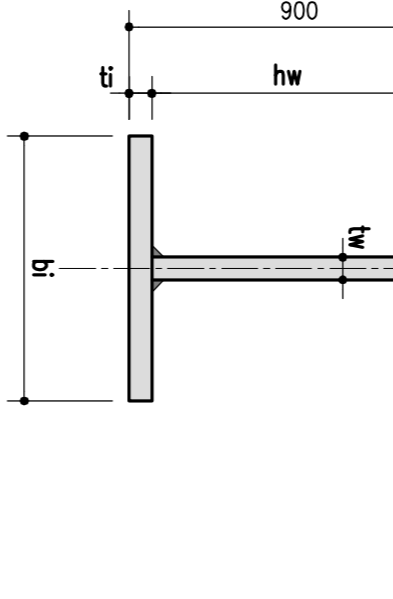

TIPOLOGIA CONCII

A	B	C	D
Bs	600	600	600
h	50	50	50
Tw	1300	1300	1300
Bs	200	200	200
h	50	50	50
Tw	800	800	800
Bs	100	100	100
h	50	50	50
Tw	400	400	400

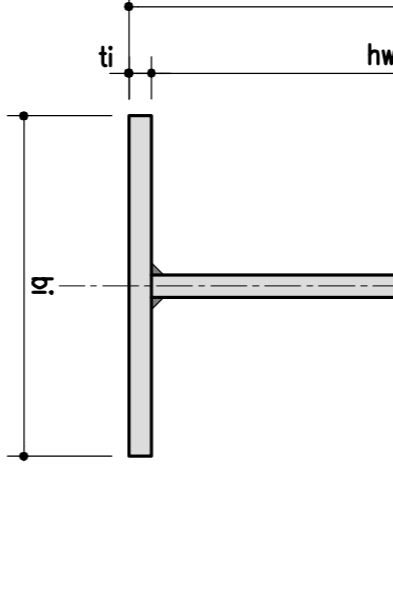

TIPOLOGIA CONCII

A	B	C	D
Bs	600	600	600
h	50	50	50
Tw	1300	1300	1300
Bs	200	200	200
h	50	50	50
Tw	800	800	800
Bs	100	100	100
h	50	50	50
Tw	400	400	400

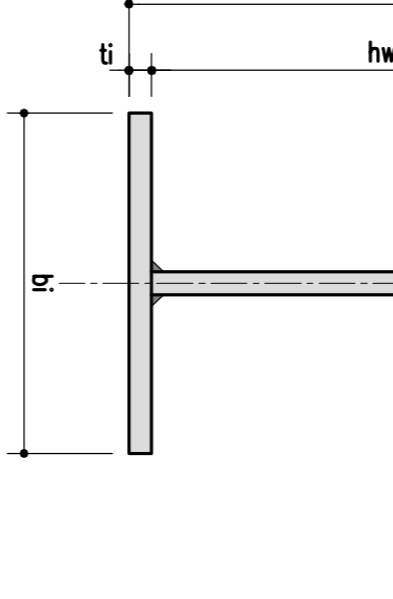

TIPOLOGIA CONCII

A	B	C	D
Bs	500	500	500
h	50	50	50
Tw	1100	1100	1100
Bs	200	200	200
h	50	50	50
Tw	600	600	600
Bs	100	100	100
h	50	50	50
Tw	300	300	300

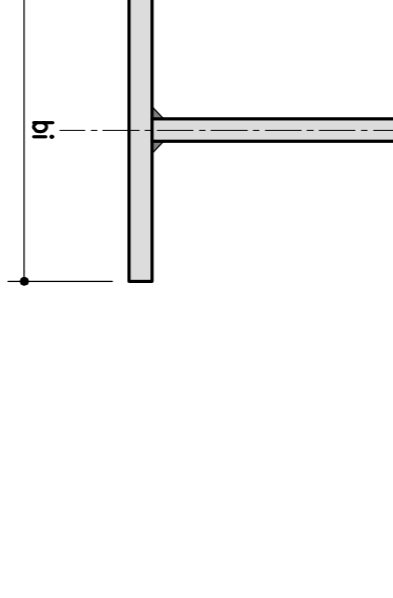

TIPOLOGIA CONCII

A	B	C	D
Bs	500	500	500
h	50	50	50
Tw	1100	1100	1100
Bs	200	200	200
h	50	50	50
Tw	600	600	600
Bs	100	100	100
h	50	50	50
Tw	300	300	300

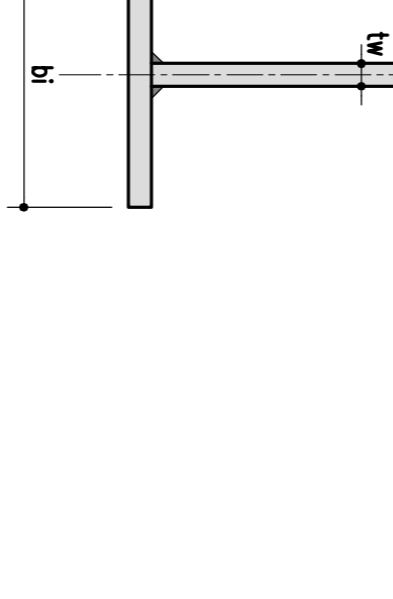

SEZIONE B-B scala (1:50)

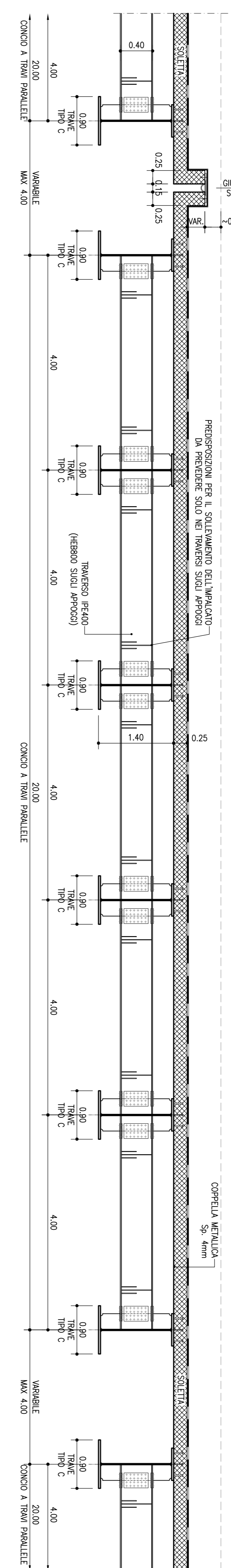

SEZIONE C-C scala (1:50)

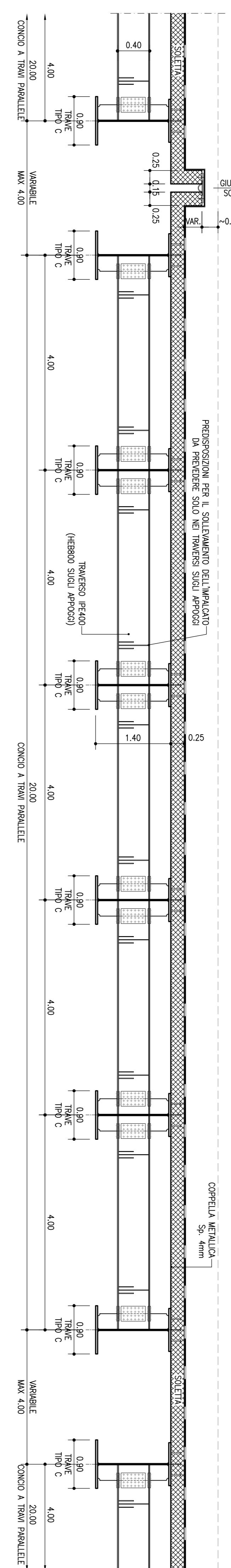

SEZIONE D-D scala (1:50)

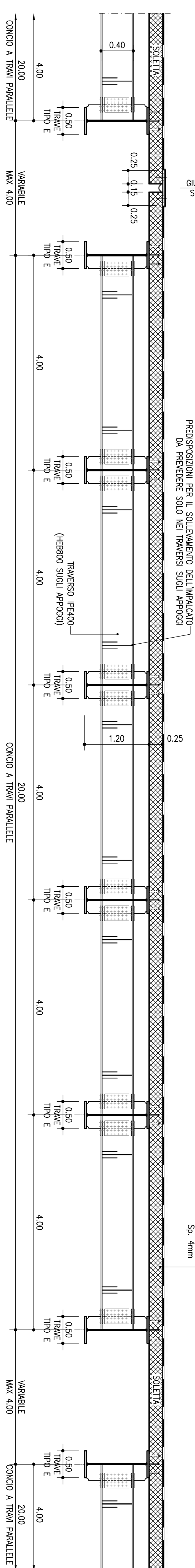

SEZIONE A-A (ZONA SPALTO) scala (1:50)

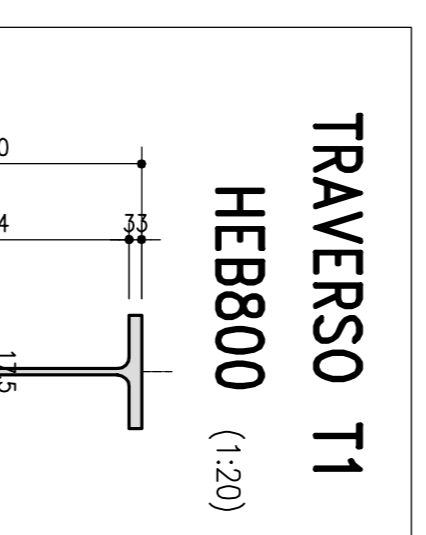
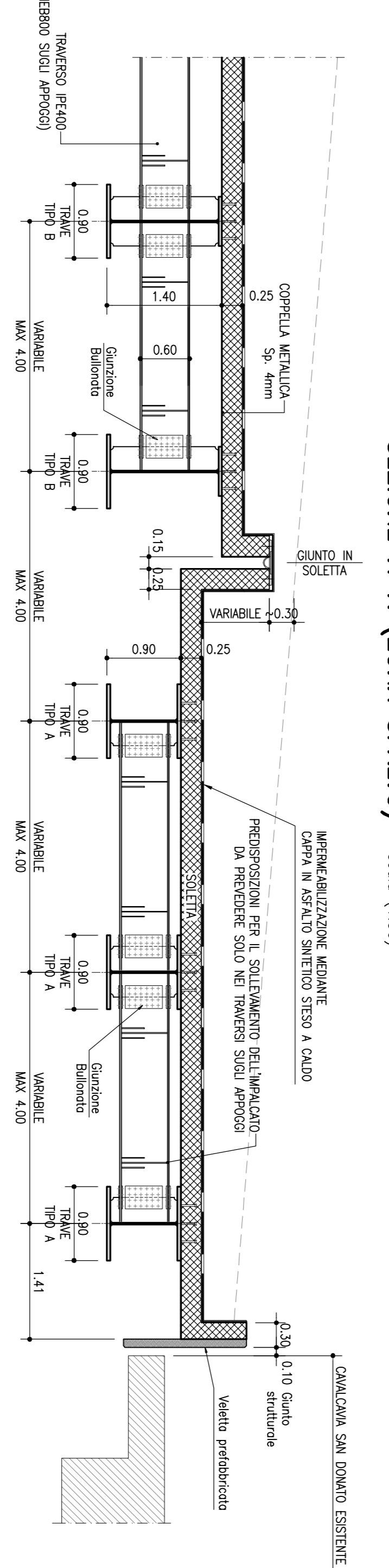

TRAVERSO T1 HE8B800 (1:20)

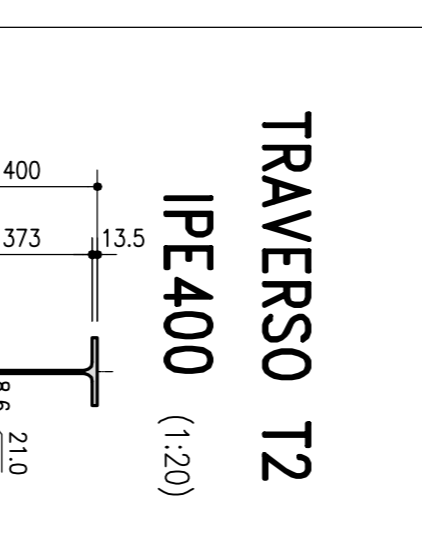

TRAVERSO T2 IPE400 (1:20)

NOTE:
- Questo tipo di travessa è stata scelta in base alle caratteristiche tecniche e di resistenza del tipo di travessa IPE 400, con sezione IPE 400, con sezione IPE 400.

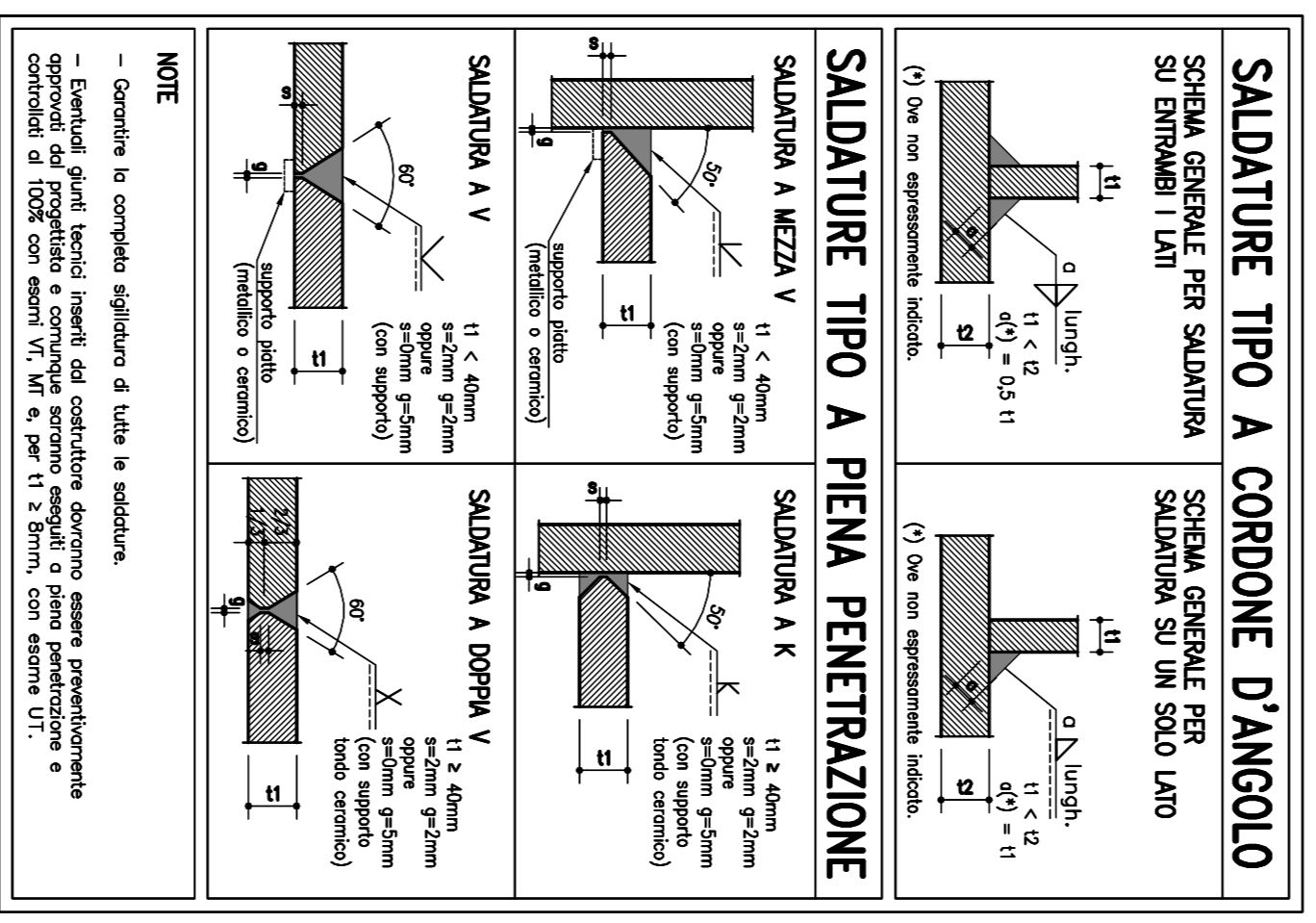

NOTA BENE:
L'INTERNO IMPALCATO IN CARPENTERIA METALLICA VERBA, TRATTATO CON SPECIFICA VERNICE INTIMESCENTE.

NOTA:
PER IL GETTO DELLA SOLETTA SI PREVEDE L'UTILIZZO DI COPPELE METALLICHE PREARMATE A PERDEE DI TIPO COMMERCIALE, DOMINE DI MARCHIADA C.E.

autostrade per italia

AUTOSTRADA A14 / TANGENZIALE
GALLERIA ARTIFICIALE FONICA - SAN DONNINO
DISEGNI STRUTTURALI DI INSIEME

IMPALCATO METALLICO - CARPENTERIA - TAN. 4/2

PROGETTO	REDAZIONE	VERIFICA	APPRVAZIONE
ING. RICCARDO BIANCHI	ING. RICCARDO BIANCHI	ING. RICCARDO BIANCHI	ING. RICCARDO BIANCHI

spca
SOCIETA PER AZIONI
Via S. Maria Nuova, 100 - 41012 Parma (PR)
Tel. +39 0521 231111 - Fax +39 0521 231112
www.spca.it

consorzio per italia
Via S. Maria Nuova, 100 - 41012 Parma (PR)
Tel. +39 0521 231111 - Fax +39 0521 231112
www.conorzio-per-italia.it

VERBA
Via S. Maria Nuova, 100 - 41012 Parma (PR)
Tel. +39 0521 231111 - Fax +39 0521 231112
www.verba.it

ING. RICCARDO BIANCHI
Via S. Maria Nuova, 100 - 41012 Parma (PR)
Tel. +39 0521 231111 - Fax +39 0521 231112
www.riccardo-bianchi.it