

S.S.131 DI "CARLO FELICE"
Adeguamento e messa in sicurezza della S.S.131
Risoluzione dei nodi critici 2° stralcio
dal km 108+300 al km 158+000

PROGETTO ESECUTIVO

CA284

R.T.I. di PROGETTAZIONE:

Mandataria



**PRO
ITER**
Progetto
Infrastrutture
Territorio s.r.l.

Via G.B. Sammartini n°5
20125 - Milano
Tel. 02 6787911
email: mail@proiter.it

Mandante



Via Artemide n°3
92100 Agrigento
Tel. 0922 421007
email: deltaingegneria@pec.it

PROGETTISTI:

Ing. Riccardo Formichi - Pro Iter srl (Integratore prestazioni specialistiche)
Ordine Ing. di Milano n. 18045

Ing. Nicola D'Alessandro - Delta Ingegneria srl
Ordine Ing. di Agrigento n. A995

IL GEOLOGO

Dott. Geol. Massimo Mezzanatica - Pro Iter srl
Albo Geol. Lombardia n. A762

COORDINATORE PER LA SICUREZZA IN FASE DI PROGETTAZIONE

Ing. Diego Ceccherelli
Ordine Ing. di Milano n. 15813

VISTO: IL RESP. DEL PROCEDIMENTO

Dott. Ing. Salvatore Frasca

PROTOCOLLO

DATA



PROGETTO STRADALE

Adeguamento svincolo esistente di Campeda al Km 152.00

Sezioni trasversali rampe B, D, rotatoria Campeda e rampa uscita SS131

CODICE PROGETTO

PROGETTO LIV. PROG. N. PROG.

LOPLSQ E 1901

NOME FILE

V11PS00TRASZ01C

CODICE ELAB. V11PS00TRASZ01

REVISIONE

SCALA

C

1:200

REV.	DESCRIZIONE	DATA	REDATTO	VERIFICATO	APPROVATO
D					
C	REVISIONE PER ISTRUTTORIA, VERIFICA E CONTROLLI D.LGS. 35/11	Agosto 2020	Ing.D. D'ALESSANDRO	Ing. M. CARLINO	Ing.N. D'ALESSANDRO
B	Emissione	Marzo 2020	Ing.D. D'ALESSANDRO	Ing. M. CARLINO	Ing.N. D'ALESSANDRO
A	Emissione per controlli D.LGS. 35/2011	Novembre 2019	Ing.D. D'ALESSANDRO	Ing. M. CARLINO	Ing.N. D'ALESSANDRO

V11

Svincolo Campeda al km 152+000

RAMPA – B

SCAVI E BONIFICHE	
STERRO	3,694 m ²
SCOTICO	2,629 m
RILEVATI	
RILEVATO	1,178 m ²
TERRENO VEGETALE	3,128 m
SOVRASTRUTTURA STRADALE	
STRATI LEGATI	6,000 m
STRATO DI FONDAZIONE	1,819 m ²
MANUFATTI	
CANALETTA	0,209 m ²

SEZIONE N.: 2
 QT. PROGETTO: 659,269
 DIST.PROG.: 25,000
 DIST.PREC.: 25,000
 DIST.SUCC.: 2,190

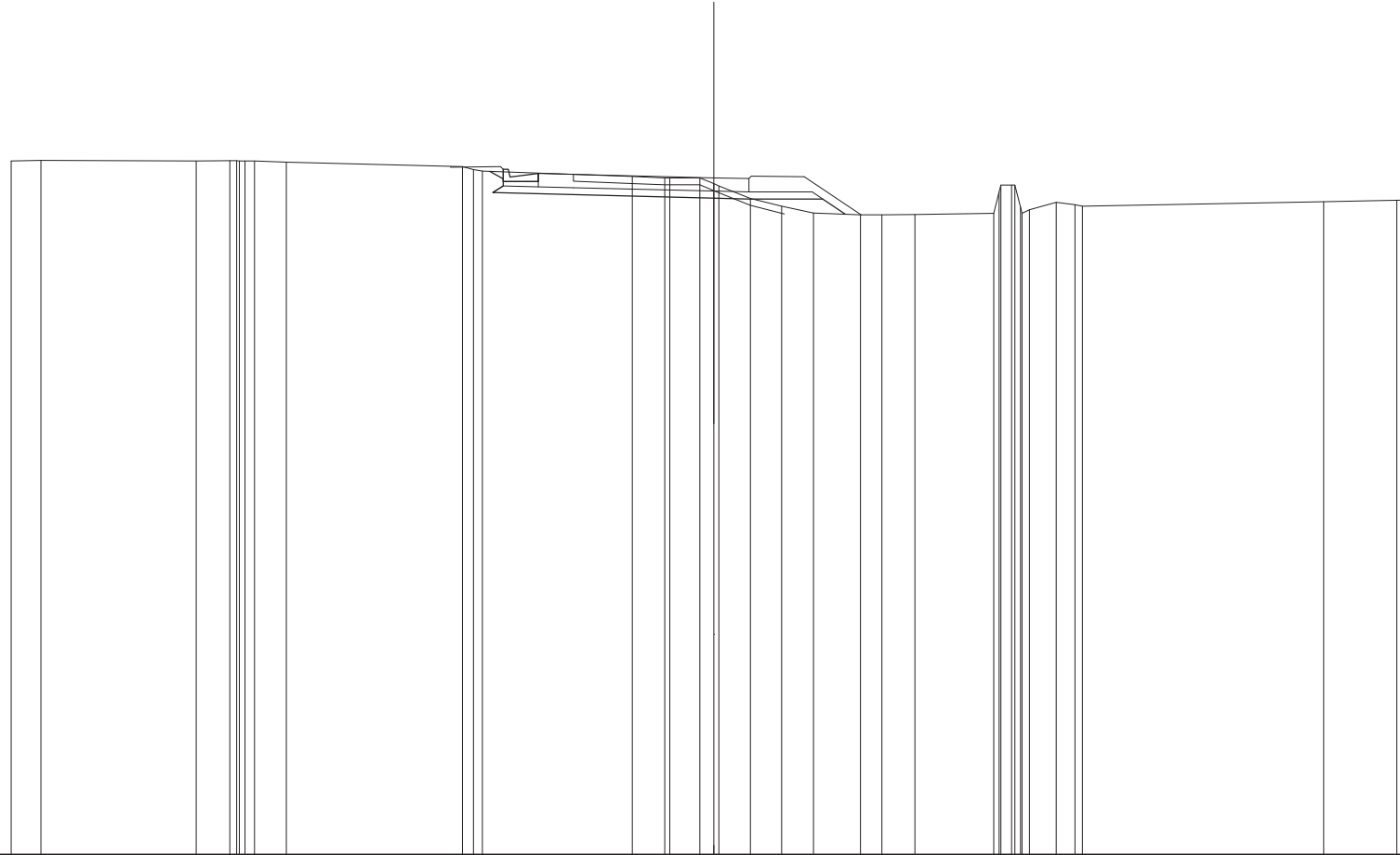

SCALA 1:200

QT.RIF. 640,000

QUOTE TERRENO	659,747 659,761	659,750 659,752 659,752 659,751 659,747 659,716	659,584 659,505 659,462	659,308 659,268 659,268 659,267 659,100 659,040 659,662 659,461 659,265	659,218 659,213 659,224	659,260 659,865 659,060 659,061 659,439 659,361 659,359 659,570 659,500 659,460	659,589	659,629 659,635			
DIST.PARZIALI TERRENO	0,848	4,415	0,866 0,904	5,015	4,269	0,820 0,862 0,398 0,899 0,887 0,904	1,343 0,811 0,835	2,249	0,783 0,832	6,868	2,083 0,558
QUOTE PROGETTO			659,455 659,846 659,038 659,238	659,789		659,689 659,664 659,664 659,233					
DIST.PARZIALI PROGETTO			2,000	4,000	1,000	2,100	0,848				
QUOTE PAVIMENTATO			659,013 659,383 659,369		659,269 659,664 659,244						
DIST.PARZIALI PAVIMENTATO			1,000	4,000	1,000						

SCAVI E BONIFICHE	
STERRO	3,723 m ²
SCOTICO	2,617 m
RILEVATI	
RILEVATO	1,160 m ²
TERRENO VEGETALE	3,128 m
SOVRASTRUTTURA STRADALE	
STRATI LEGATI	6,000 m
STRATO DI FONDAZIONE	1,819 m ²
MANUFATTI	
CANALETTA	0,209 m ²

SEZIONE N.: 3
 QT. PROGETTO: 659,312
 DIST.PROG.: 27,190
 DIST.PREC.: 2,190
 DIST.SUCC.: 22,810

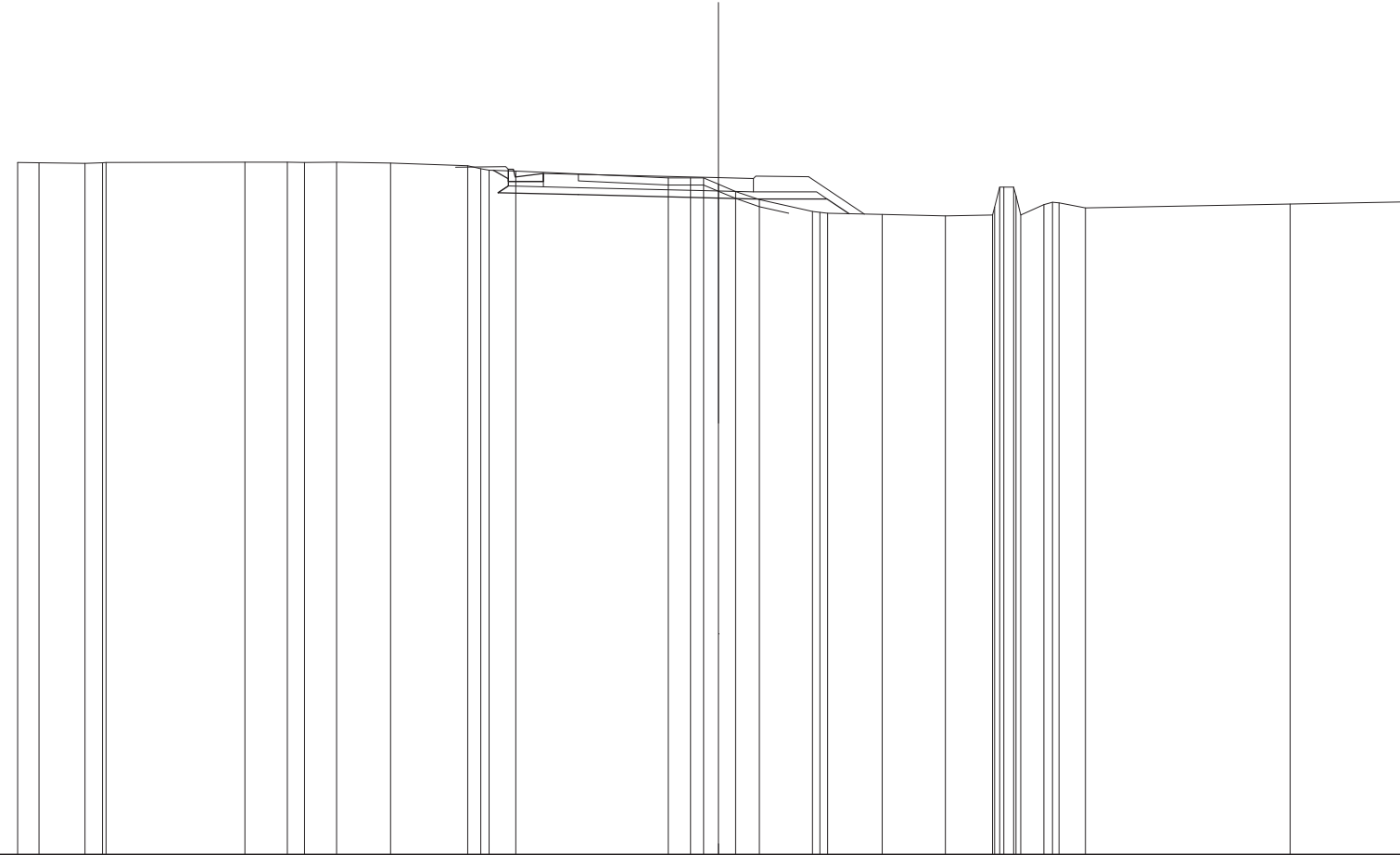

SCALA 1:200

QT.RIF. 640,000

QUOTE TERRENO	659,746 659,741 659,724 659,740 659,748	659,768	659,760 659,761 659,754	659,729	659,651 659,589 659,530 659,501	659,307 659,307 659,126 659,921 659,698	659,348 659,325 659,298	659,296	659,226	659,248 659,480 659,048 659,048 659,802 659,248 659,548 659,616 659,592 659,450	659,562	659,624 659,630
DIST.PARZIALI TERRENO	0,610 1,309 0,499	3,982	1,212 0,487 0,918	1,538 2,200	0,770	4,351	0,635 0,428 0,487 0,684	1,513	1,563 1,799 1,348	0,680 0,754	5,842	3,188 0,499
QUOTE PROGETTO					659,525 659,887 659,079 659,279	659,830	659,732 659,707	659,707 659,285				
DIST.PARZIALI PROGETTO					2,000	4,000	1,000 2,100	0,632				
QUOTE PAVIMENTATO					659,055 659,435 659,410		659,312 659,907 659,287					
DIST.PARZIALI PAVIMENTATO					1,000	4,000	1,000					

SCAVI E BONIFICHE	
STERRO	1,213 m ²
SCAVO A GRADONI	6,713 m
RILEVATI	
RILEVATO	0,483 m ²
TERRENO VEGETALE	1,599 m
SOVRASTRUTTURA STRADALE	
STRATI LEGATI	4,479 m
STRATO DI FONDAZIONE	1,286 m ²

SEZIONE N.: 12
 QT. PROGETTO: 660,314
 DIST.PROG.: 225,000
 DIST.PREC.: 25,000
 DIST.SUCC.: 25,000

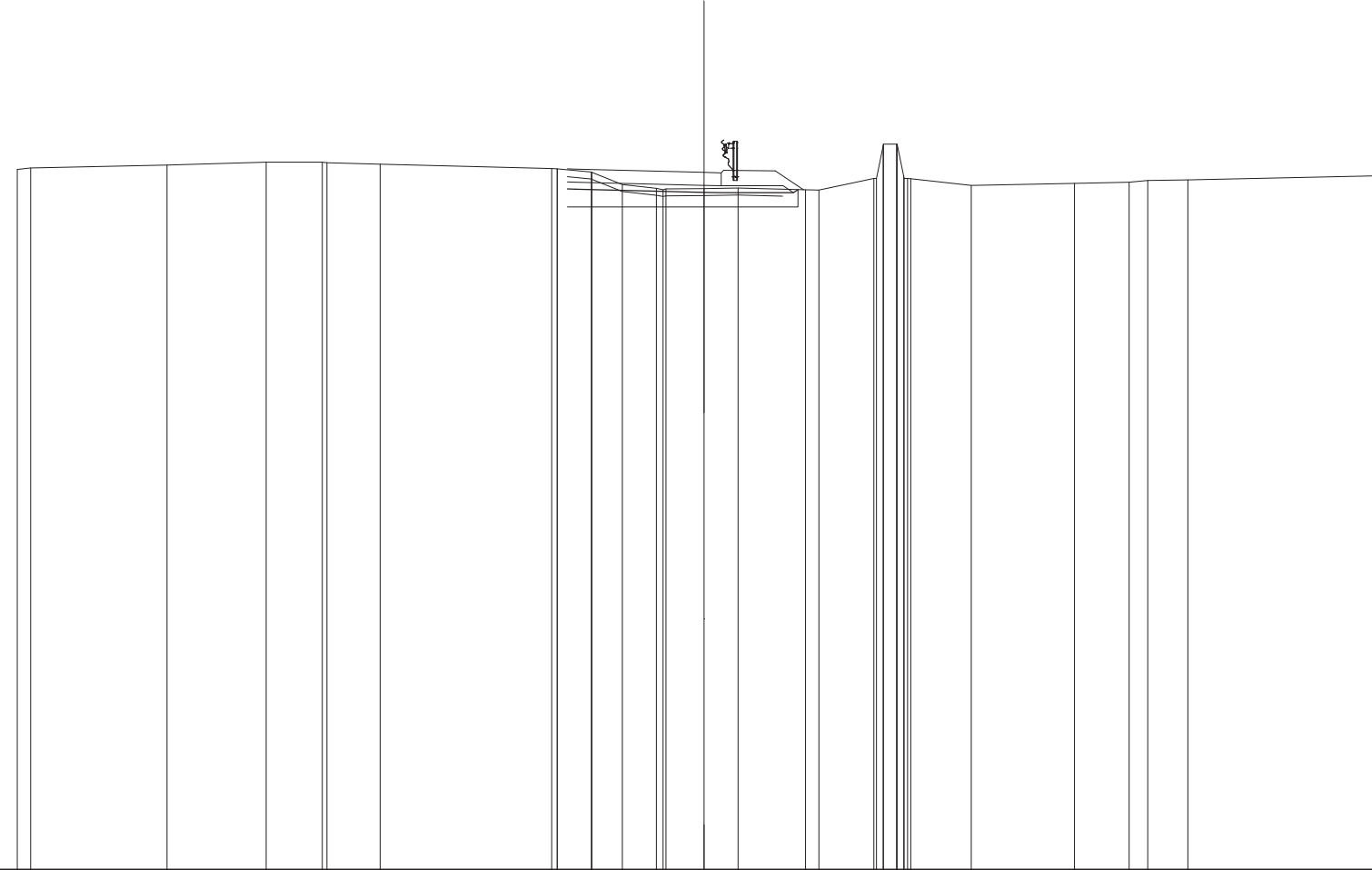

SCALA 1:200

QT.RIF. 640,000

QUOTE TERRENO	660,403 660,441	660,530	660,608	660,608 660,593	660,551	4,996	660,423 660,420 660,420 660,320 660,318 660,315 659,955 659,848 659,809 659,823 659,841 659,863	659,805 659,799	660,141 660,137 661,084 661,136 661,136 660,190 660,196 660,198 660,198 659,931	659,985	660,029 660,075	660,081	660,219
DIST.PARZIALI TERRENO	3,968	2,890	1,634	1,548	4,996	0,884 0,881 0,888 1,110 0,888	1,964	0,389 1,599	1,764	3,002	1,588	0,547 1,108	5,912
QUOTE PROGETTO						659,833 659,828	659,734 659,721	659,721 659,811					
DIST.PARZIALI PROGETTO						3,750	0,600	2,100					
QUOTE PAVIMENTATO						660,413 660,408	660,314 659,921 660,301						
DIST.PARZIALI PAVIMENTATO						3,750	0,600						

SCAVI E BONIFICHE	
STERRO	1,354 m ²
SCOTICO	0,122 m
SCAVO A GRADONI	5,629 m
RILEVATI	
RILEVATO	0,329 m ²
TERRENO VEGETALE	1,599 m
SOVRASTRUTTURA STRADALE	
STRATI LEGATI	4,026 m
STRATO DI FONDAZIONE	1,195 m ²

SEZIONE N.: 13
 QT. PROGETTO: 660,409
 DIST.PROG.: 250,000
 DIST.PREC.: 25,000
 DIST.SUCC.: 4,377



SCALA 1:200

QT.RIF. 640,000

QUOTE TERRENO	660,462 660,512 660,536	660,663 660,672 660,672	660,672 660,663	660,575	660,523 660,487 660,423	660,187 660,128	659,955 659,927 659,927 659,927	659,962	660,077	660,036 660,306 661,036 661,036 660,305 660,036 660,015 659,862	659,938	659,893	659,923 659,931
DIST.PARZIALI TERRENO	0,488	5,783	1,088 1,749	0,423 4,019	2,332	0,654 0,611 1,177	0,648 0,622	1,302 2,442	1,032	0,541 2,010	3,687	4,057	2,839 0,688
QUOTE PROGETTO					659,917		659,829 659,817	659,817 660,007					
DIST.PARZIALI PROGETTO						3,526	0,500	2,100					
QUOTE PAVIMENTATO					660,487		660,409 660,017 660,387						
DIST.PARZIALI PAVIMENTATO						3,526	0,500						

SCAVI E BONIFICHE	
STERRO	1,060 m ²
SCAVO A GRADONI	6,149 m
RILEVATI	
RILEVATO	0,561 m ²
TERRENO VEGETALE	1,599 m
SOVRASTRUTTURA STRADALE	
STRATI LEGATI	3,917 m
STRATO DI FONDAZIONE	1,173 m ²

SEZIONE N.: 14
 QT. PROGETTO: 660,426
 DIST.PROG.: 254,377
 DIST.PREC.: 4,377
 DIST.SUCC.: 20,623

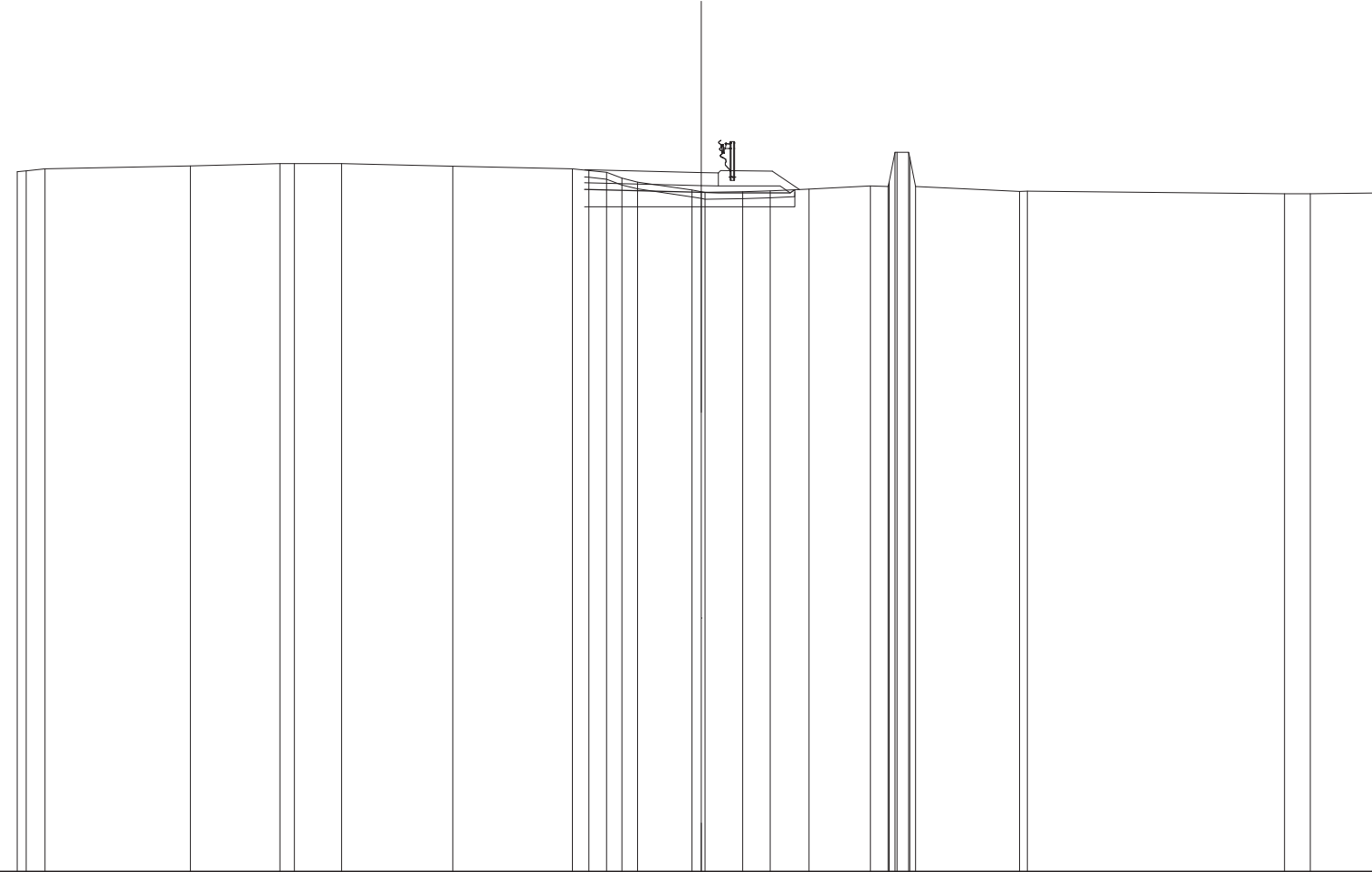

SCALA 1:200

QT.RIF. 640,000

QUOTE TERRENO	660,453 660,478 660,534	660,620	660,663 660,663	660,664	660,613	660,533 660,485 660,433 660,261 660,149	659,915 659,868 659,850 659,866 659,888 659,941	660,033 660,016 660,016 661,015 661,015 660,867 660,015	659,878 659,864	659,804 659,810	659,832		
DIST.PARZIALI TERRENO	0,557	4,247	2,618	0,426 1,376	3,256	3,494	0,460 0,521 0,448 0,463 1,593	1,104 0,802 1,132	1,798	0,519	3,045	7,522	0,757 2,191
QUOTE PROGETTO						659,931	659,846 659,833	659,833 659,921					
DIST.PARZIALI PROGETTO						3,417	0,500 2,100						
QUOTE PAVIMENTATO						660,511	660,426 660,033 660,413						
DIST.PARZIALI PAVIMENTATO						3,417	0,500						

SCAVI E BONIFICHE	
STERRO	0,563 m ²
SCOTICO	3,841 m
SCAVO A GRADONI	5,387 m
RILEVATI	
RILEVATO	1,494 m ²
TERRENO VEGETALE	1,599 m
SOVRASTRUTTURA STRADALE	
STRATI LEGATI	2,920 m
STRATO DI FONDAZIONE	0,974 m ²

SEZIONE N.: 15
 QT. PROGETTO: 660,492
 DIST.PROG.: 275,000
 DIST.PREC.: 20,623
 DIST.SUCC.: 25,000

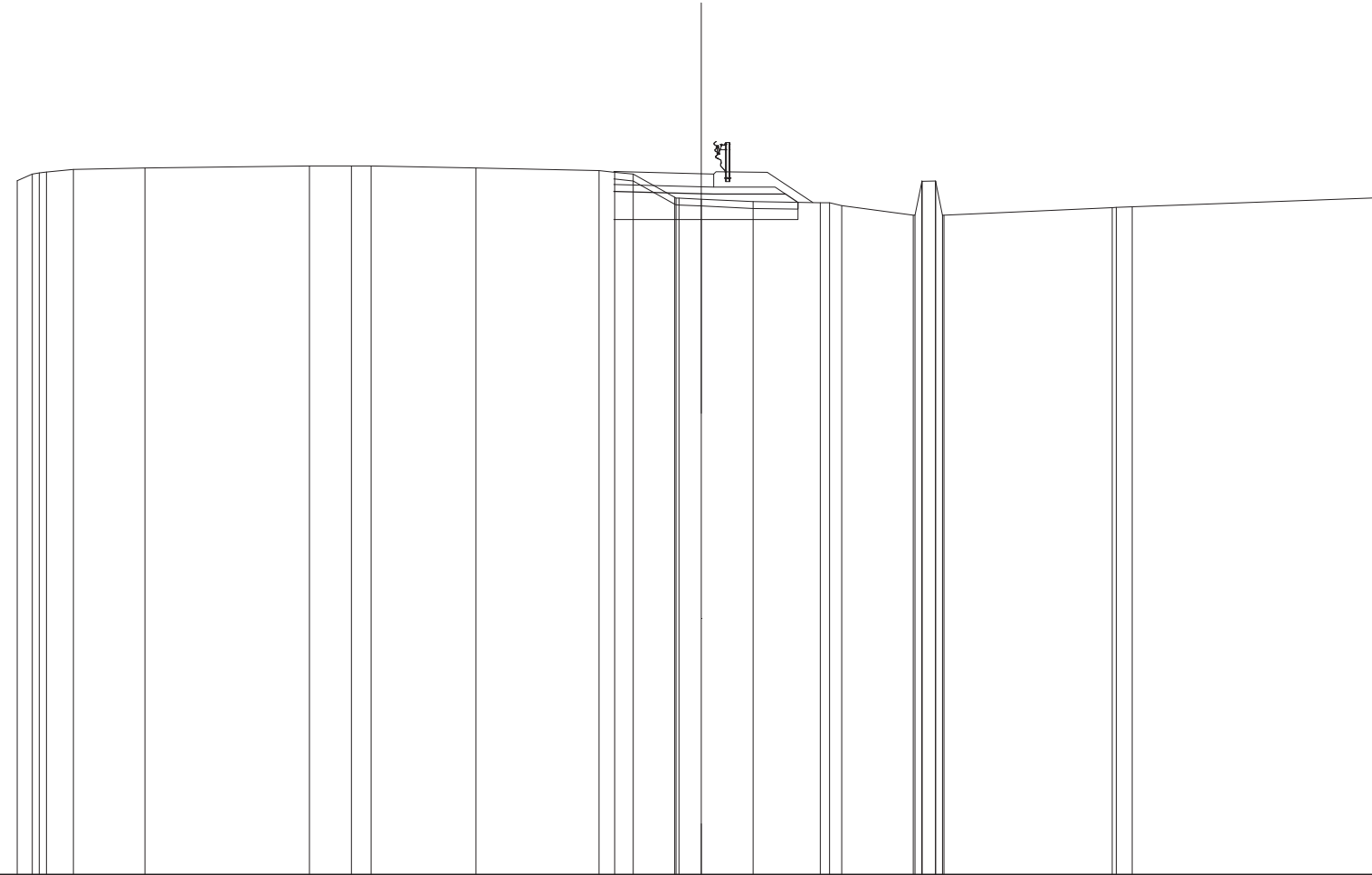

SCALA 1:200

QT.RIF. 640,000

QUOTE TERRENO	660,292 660,481 660,520 660,541 660,621	660,665	660,721 660,721 660,721	660,665	660,563 660,537 660,483	659,807 659,785 659,762 659,750	659,676	659,649 659,644 659,565	659,284 659,278 660,278 660,278 660,277 660,277 660,277	659,504 659,512 659,531	659,798			
DIST.PARZIALI TERRENO	0,439 0,792	2,090	4,808	1,231 0,572	3,069	3,596	0,480 0,542 1,214	0,666 1,511	1,967	2,090	0,400	4,914	0,472	7,397
QUOTE PROGETTO						659,976		659,912 659,903	659,903 659,658					
DIST.PARZIALI PROGETTO							2,557	2,100						
QUOTE PAVIMENTATO						660,566		660,482 660,413 660,483						
DIST.PARZIALI PAVIMENTATO							2,557							

SCAVI E BONIFICHE	
STERRO	0,544 m ²
SCOTICO	2,760 m
SCAVO A GRADONI	4,349 m
RILEVATI	
RILEVATO	1,432 m ²
TERRENO VEGETALE	1,599 m
SOVRASTRUTTURA STRADALE	
STRATI LEGATI	1,710 m
STRATO DI FONDAZIONE	0,732 m ²

SEZIONE N.: 16
 QT. PROGETTO: 660,572
 DIST.PROG.: 300,000
 DIST.PREC.: 25,000
 DIST.SUCC.: 25,000

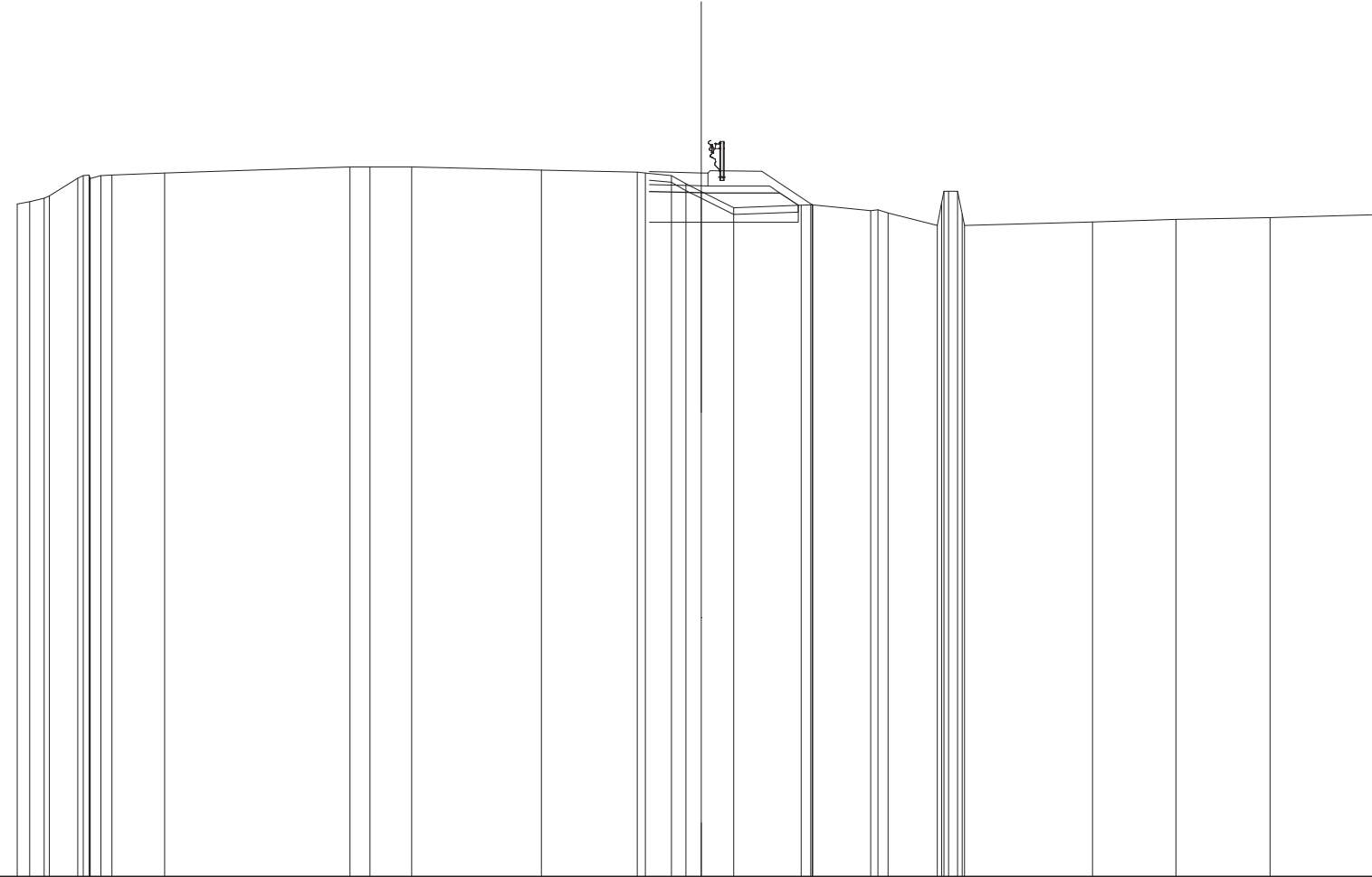

SCALA 1:200

QT.RIF. 640,000

QUOTE TERRENO	659,661 659,726 659,830 659,900 660,413 660,494 660,505 660,438 660,406 660,493 660,512 660,568	660,745 660,745 660,746	660,653	660,596 660,572	660,496 660,254 660,028	660,566	659,631 659,634 659,644 659,638	659,468 659,497 659,386	659,088 659,706 660,038 660,038 660,038 659,368 659,038	659,141	659,217	659,268	659,368	
DIST.PARZIALI TERRENO	0,429 0,630	1,540	5,417	0,588 1,216	3,792	2,804	0,762 0,432 0,451 0,944	1,974	1,694	1,434	3,742	2,440	2,751	3,369
QUOTE PROGETTO							660,030 660,982 660,987	660,987 660,628						
DIST.PARZIALI PROGETTO							1,514	2,100	0,539					
QUOTE PAVIMENTATO							660,810 660,572 660,712 660,567							
DIST.PARZIALI PAVIMENTATO							1,514							

V11

Svincolo Campeda al km 152+000

RAMPA – D

SCAVI E BONIFICHE	
STERRO	4,846 m ²
RILEVATI	
RILEVATO	0,069 m ²
TERRENO VEGETALE	1,599 m
SOVRASTRUTTURA STRADALE	
STRATI LEGATI	5,999 m
STRATO DI FONDAZIONE	1,819 m ²
MANUFATTI	
CANALETTA	0,208 m ²

SEZIONE N.: 2
 QT. PROGETTO: 659,355
 DIST.PROG.: 17,164
 DIST.PREC.: 17,164
 DIST.SUCC.: 7,836

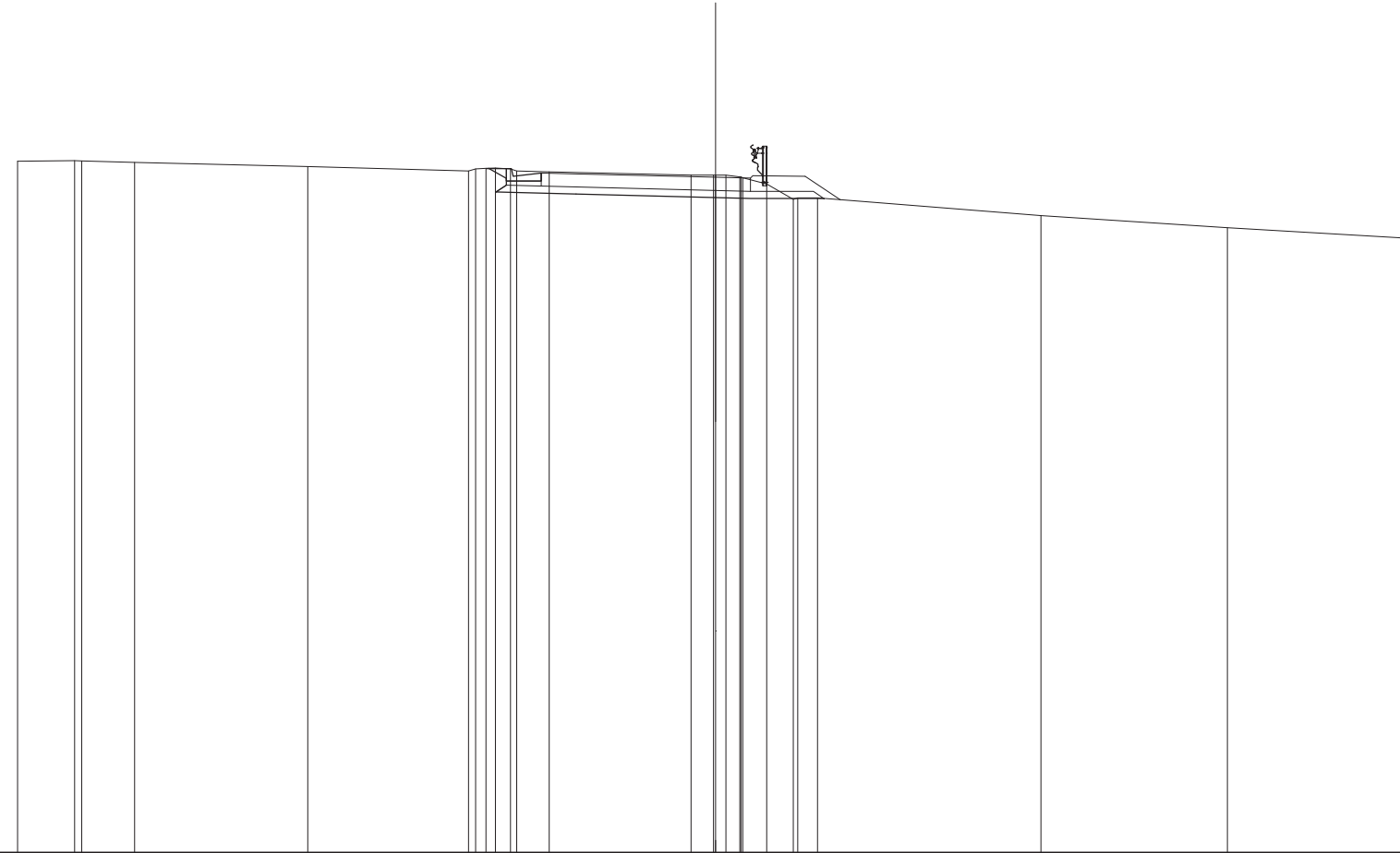

SCALA 1:200

QT.RIF. 640,000

QUOTE TERRENO	659,812	659,830 659,822	659,783	659,668	659,534 659,598 659,612 659,595 659,537 659,511	659,420	659,420 659,420 659,366 659,365 659,337 659,165 659,719 659,763 659,761	658,260	657,906	657,615 657,601
DIST.PARZIALI TERRENO	1,634	1,516	4,964	4,802	4,061	0,648	0,394 0,688 0,766 0,587	6,396	5,350	5,078
QUOTE PROGETTO					659,600 659,614 659,932 659,125 659,625 659,600 659,875	658,775	658,750	658,750 658,747		
DIST.PARZIALI PROGETTO					2,000	4,000	0,989	2,100		
QUOTE PAVIMENTATO					659,100 659,480 659,455	659,355	659,330 659,950			
DIST.PARZIALI PAVIMENTATO					1,000	4,000	0,989			

SCAVI E BONIFICHE	
STERRO	4,343 m ²
RILEVATI	
RILEVATO	0,020 m ²
TERRENO VEGETALE	1,599 m
SOVRASTRUTTURA STRADALE	
STRATI LEGATI	5,729 m
STRATO DI FONDAZIONE	1,536 m ²

SEZIONE N.: 3
 QT. PROGETTO: 659,384
 DIST.PROG.: 25,000
 DIST.PREC.: 7,836
 DIST.SUCC.: 9,329

SCALA 1:200

QT.RIF. 640,000

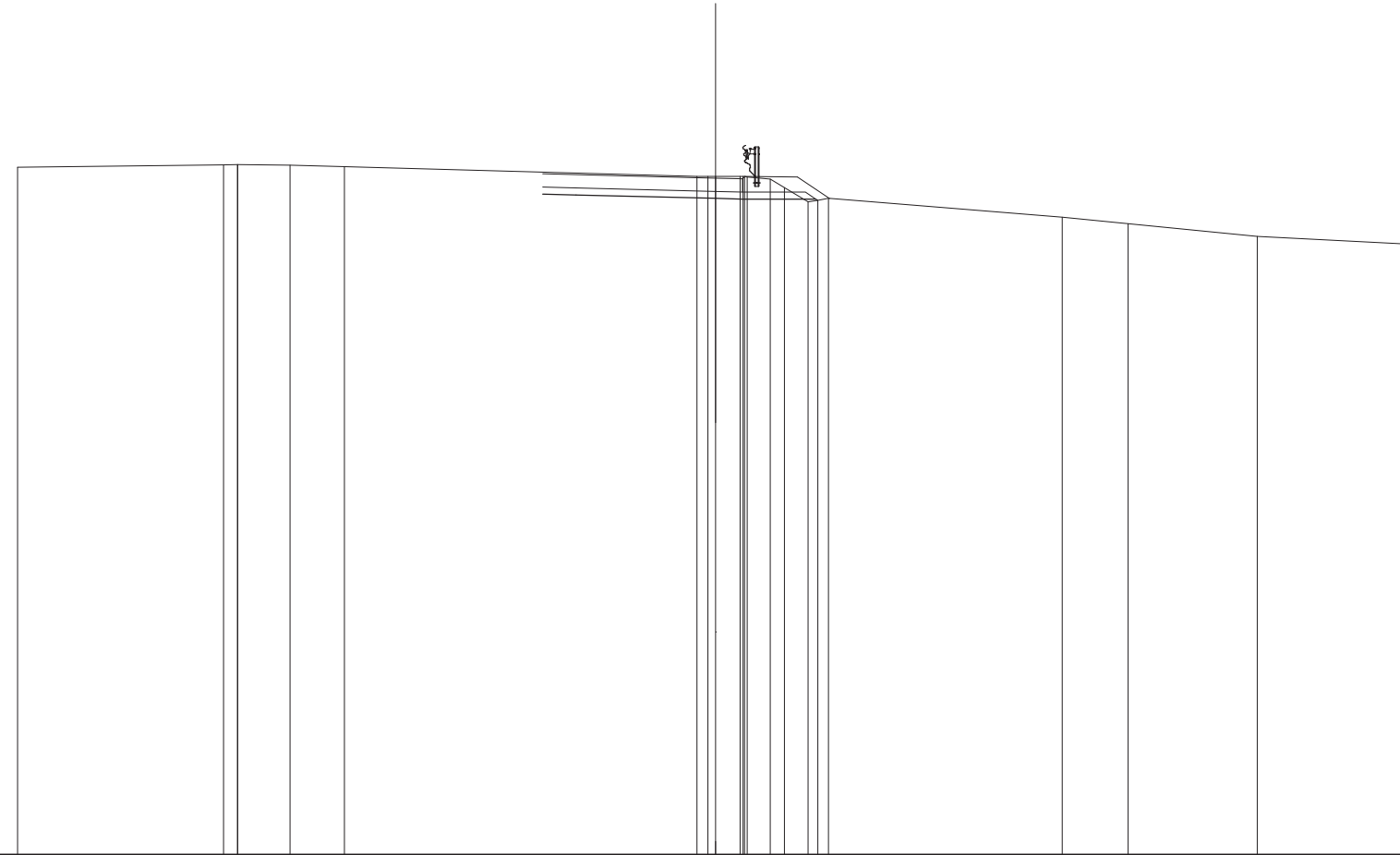

QUOTE TERRENO	659,686	659,767 659,772 659,772	659,757	659,712	659,438 659,432 659,432 659,432 659,421 659,384 659,716 659,730 659,805	656,267	656,078	657,714	657,487
DIST.PARZIALI TERRENO	5,903	0,387 1,496	1,558	10,101	0,704 0,682 0,488 0,674	6,703	1,882	3,702	4,480
QUOTE PROGETTO					658,928 658,904				
DIST.PARZIALI PROGETTO					0,968 4,000				
QUOTE PAVIMENTATO					659,508 659,484				
DIST.PARZIALI PAVIMENTATO					0,968 4,000				

SCAVI E BONIFICHE	
STERRO	3,020 m ²
SCOTICO	0,812 m
BONIFICA	0,425 m ²
RILEVATI	
RILEVATO	0,755 m ²
TERRENO VEGETALE	1,599 m
SOVRASTRUTTURA STRADALE	
STRATI LEGATI	4,000 m
STRATO DI FONDAZIONE	1,190 m ²

SEZIONE N.: 4
 QT. PROGETTO: 659,406
 DIST.PROG.: 34,329
 DIST.PREC.: 9,329
 DIST.SUCC.: 15,671

SCALA 1:200

QT.RIF. 640,000

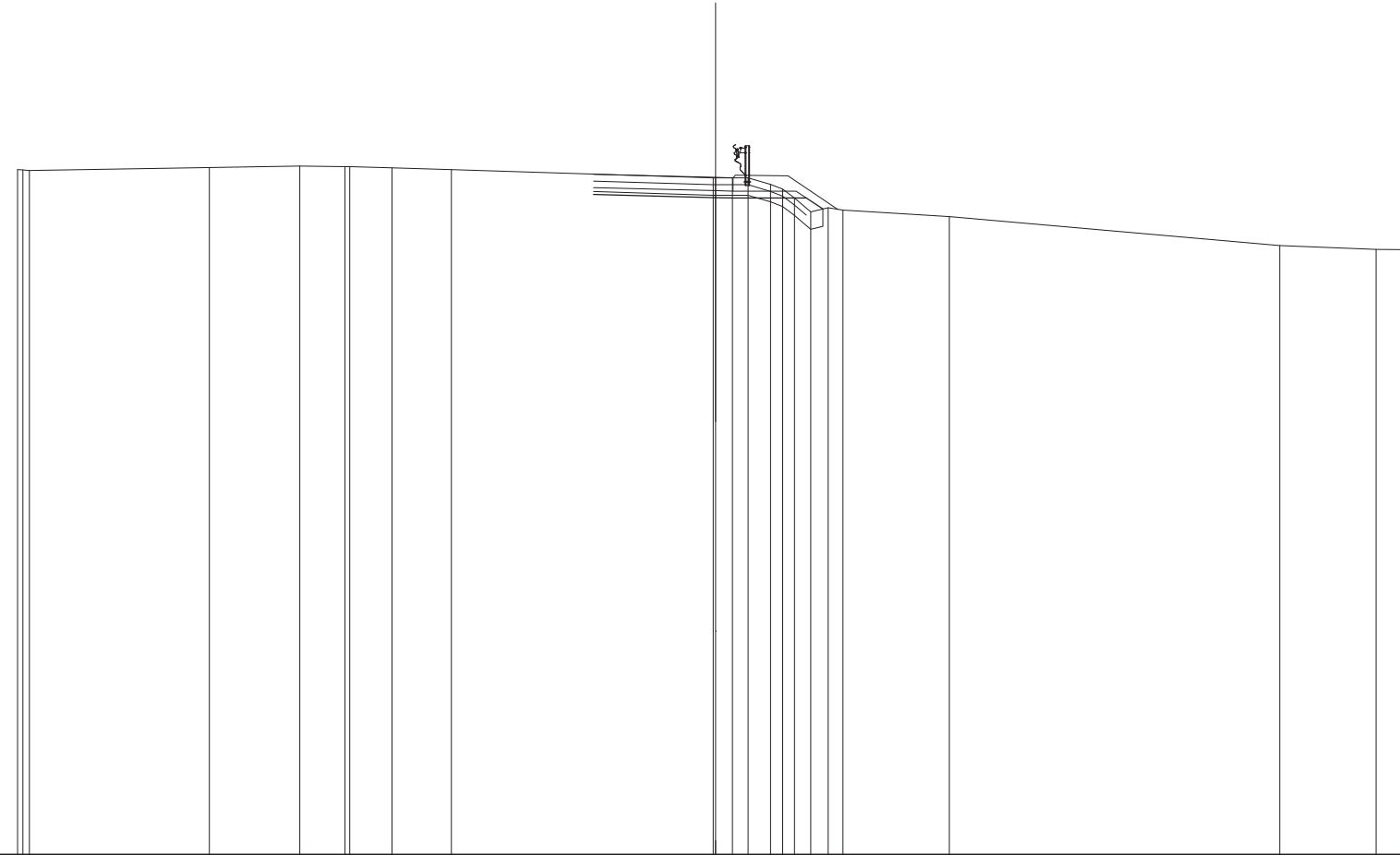

QUOTE TERRENO		659,628 659,617 659,607		659,691		659,729	659,713 659,712	659,690	659,627		659,395 659,395 659,395 659,395 659,202 659,089 659,814 659,420 659,537 659,465		658,279		657,450	657,343 657,331
DIST.PARZIALI TERRENO		5,157		2,590	1,300	1,206	1,700		7,503		0,483 0,450 0,638		3,045		9,469	2,764 1,072
QUOTE PROGETTO									658,914		658,826 658,814					
DIST.PARZIALI PROGETTO									3,500		0,500 2,100					
QUOTE PAVIMENTATO									659,494		659,406 659,014 659,394					
DIST.PARZIALI PAVIMENTATO									3,500		0,500					

SCAVI E BONIFICHE	
STERRO	3,456 m ²
SCAVO A GRADONI	5,892 m
RILEVATI	
RILEVATO	0,198 m ²
TERRENO VEGETALE	1,599 m
SOVRASTRUTTURA STRADALE	
STRATI LEGATI	4,235 m
STRATO DI FONDAZIONE	1,237 m ²

SEZIONE N.: 6
 QT. PROGETTO: 659,165
 DIST.PROG.: 75,000
 DIST.PREC.: 25,000
 DIST.SUCC.: 25,000

SCALA 1:200

QT.RIF. 640,000

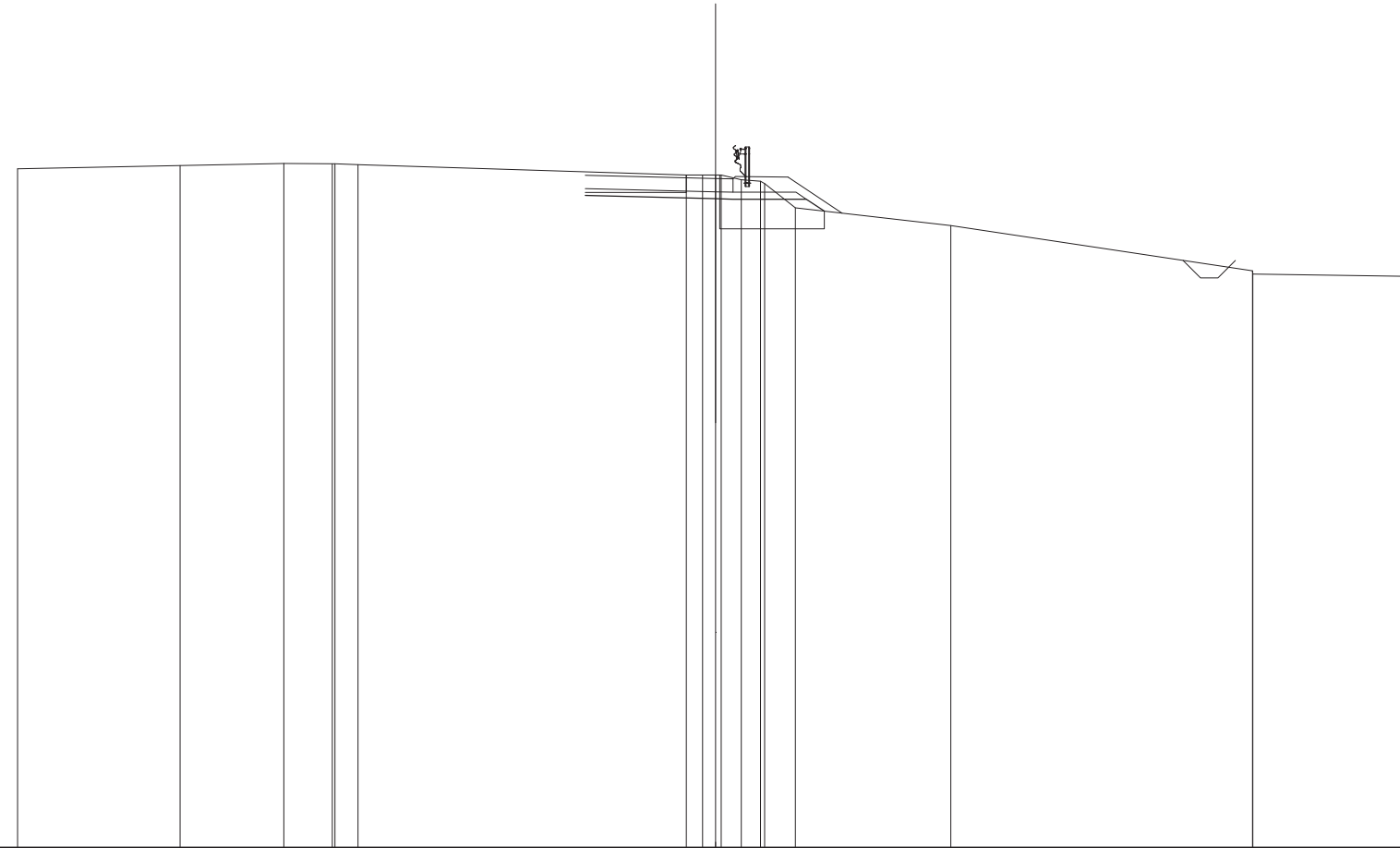

QUOTE TERRENO	659,440	659,539	659,598	659,585 659,588 659,585	659,288 659,288 659,288 659,128 659,091 659,018 656,321	657,818	656,516 656,423	656,363	
DIST.PARZIALI TERRENO	4,655	2,969	1,391	0,657	9,407	0,471 0,582 0,544 0,886	4,457	8,644	4,603
QUOTE PROGETTO					658,678		658,585 658,572		658,572 658,228
DIST.PARZIALI PROGETTO					3,735		0,500	2,100	0,516
QUOTE PAVIMENTATO					659,258		659,165 658,772 658,152		
DIST.PARZIALI PAVIMENTATO					3,735		0,500		

SCAVI E BONIFICHE	
STERRO	3,289 m ²
SCAVO A GRADONI	5,788 m
RILEVATI	
RILEVATO	0,002 m ²
TERRENO VEGETALE	1,599 m
SOVRASTRUTTURA STRADALE	
STRATI LEGATI	4,233 m
STRATO DI FONDAZIONE	1,237 m ²

SEZIONE N.: 7
 QT. PROGETTO: 659,163
 DIST.PROG.: 100,000
 DIST.PREC.: 25,000
 DIST.SUCC.: 25,000

SCALA 1:200

QT.RIF. 640,000

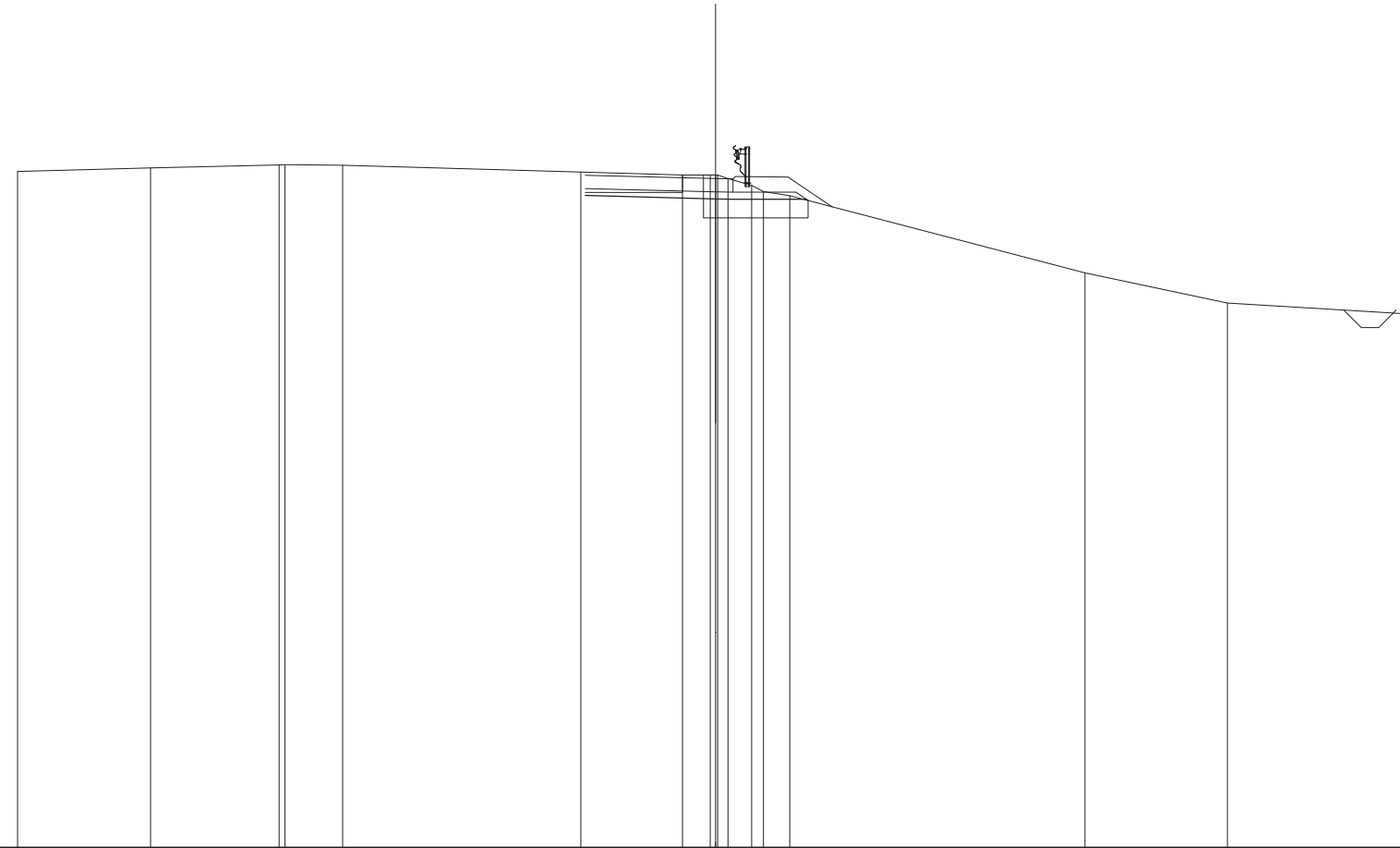

QUOTE TERRENO	659,370	659,472	659,557 659,569	659,548	659,353	659,261	659,261 659,261 659,166 659,966 659,788 659,673	659,465	659,600	659,277
DIST.PARZIALI TERRENO	3,806	3,683	1,650	6,830	2,916	0,798 0,684 0,761	8,464	4,080	5,333	
QUOTE PROGETTO					659,676	659,583 659,570	659,570 659,534			
DIST.PARZIALI PROGETTO					3,733	0,600 2,100				
QUOTE PAVIMENTATO					659,256	659,163 659,770 659,150				
DIST.PARZIALI PAVIMENTATO					3,733	0,600				

SCAVI E BONIFICHE	
STERRO	0,640 m ²
SCOTICO	7,965 m
SCAVO A GRADONI	10,040 m
RILEVATI	
RILEVATO	7,192 m ²
TERRENO VEGETALE	1,599 m
SOVRASTRUTTURA STRADALE	
STRATI LEGATI	2,136 m
STRATO DI FONDAZIONE	0,817 m ²

SEZIONE N.: 11
 QT. PROGETTO: 659,144
 DIST.PROG.: 175,000
 DIST.PREC.: 21,450
 DIST.SUCC.: 23,677

SCALA 1:200

QT.RIF. 640,000

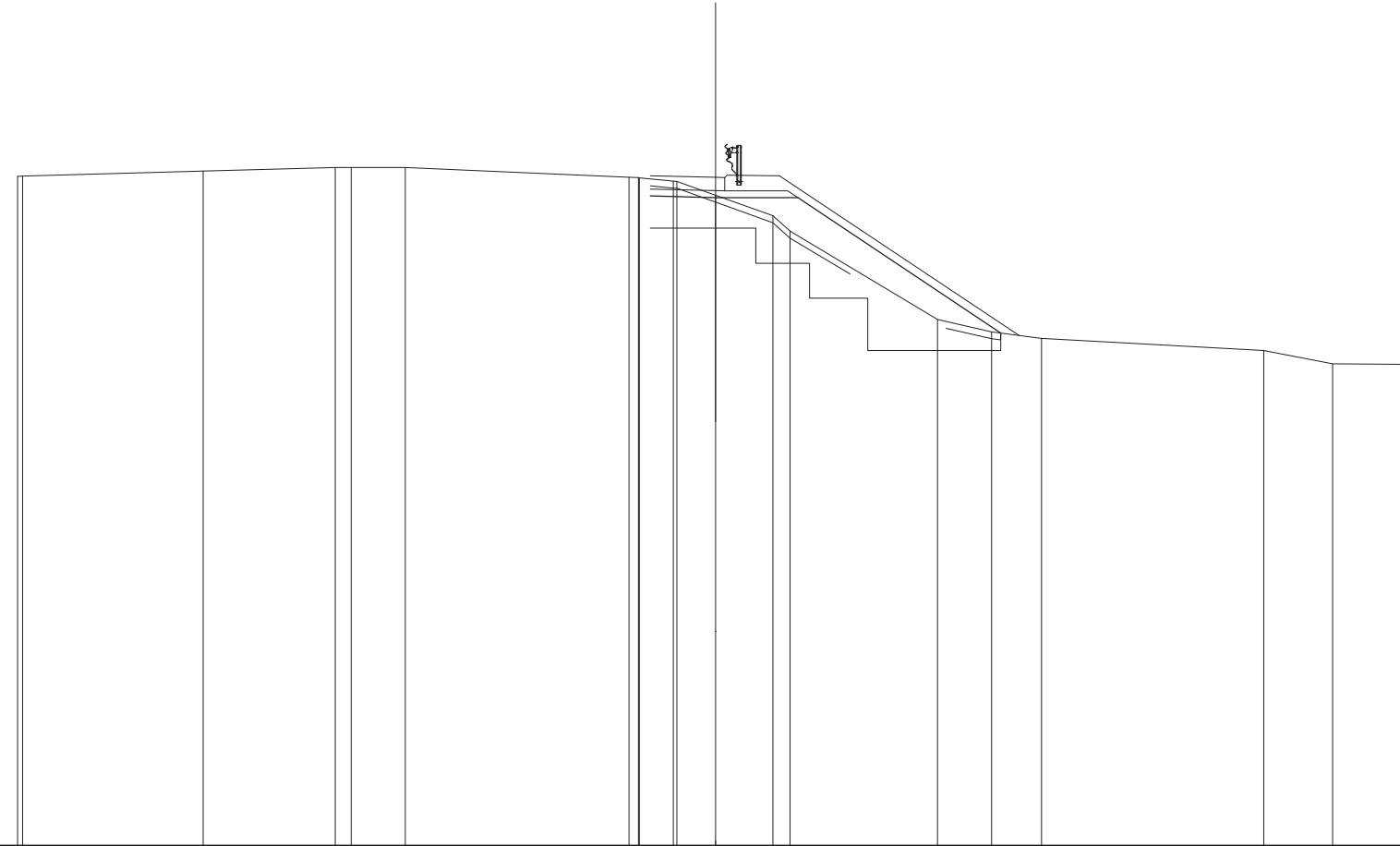

QUOTE TERRENO	659,169 659,183	659,325	659,427 659,427	659,427	659,144 659,135 659,132 659,034 659,030 658,632	658,043 657,603	655,074	654,720 654,532	654,187 653,799	653,784
DIST.PARZIALI TERRENO	5,172	3,782	0,480 1,548	6,410	0,977 1,108	1,640 0,482	4,229	1,545 1,432	6,373	1,971 2,318
QUOTE PROGETTO					658,611 658,564 658,556	658,558		654,686		
DIST.PARZIALI PROGETTO					1,874	2,100	5,805			
QUOTE PAVIMENTATO					659,191 659,144 659,138					
DIST.PARZIALI PAVIMENTATO					1,874					

V11

Svincolo Campeda al km 152+000

RAMPA – USCITA SS 131

SCAVI E BONIFICHE	
STERRO	2,855 m ²
BONIFICA	3,911 m ²
RILEVATI	
RILEVATO	4,332 m ²
TERRENO VEGETALE	3,212 m
SOVRASTRUTTURA STRADALE	
STRATO DI USURA	11,166 m
STRATO DI FONDAZIONE	2,695 m ²

SEZIONE N.: 2
 QT. PROGETTO: 658,873
 DIST.PROG.: 10,000
 DIST.PREC.: 10,000
 DIST.SUCC.: 7,842

SCALA 1:200

QT.RIF. 645,000

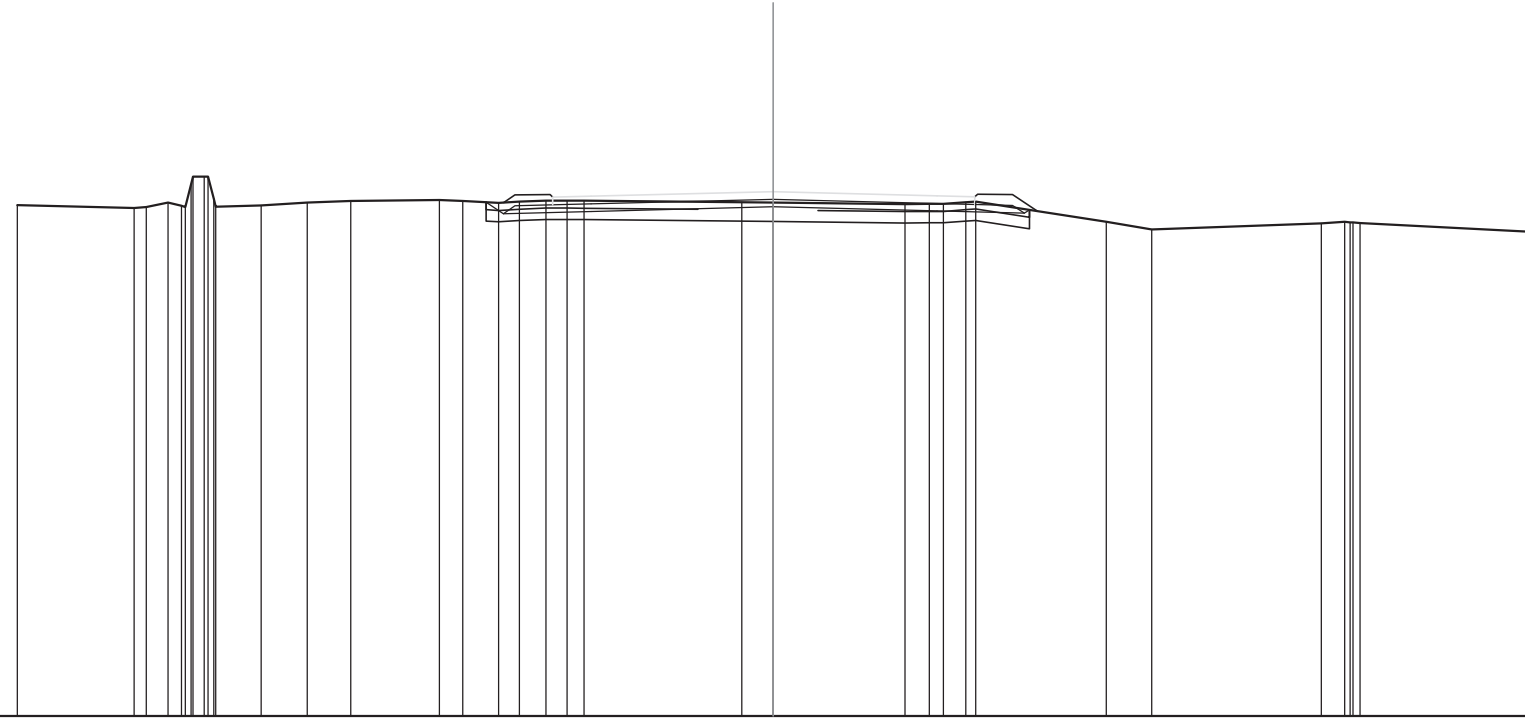

QUOTE TERRENO	658,518	658,439 658,472 658,566 658,591 658,471 659,071 659,271 659,272 659,273 658,686 658,473 658,590 658,590 658,631	658,659 658,630 658,579 658,610 658,641 658,640 658,638	658,599 658,589	658,547 658,551 658,552 658,597 658,614	658,080 657,873	658,039 658,080 658,059 658,060 658,041	657,813
DIST.PARZIALI TERRENO	3,097	0,570 1,205 1,213 1,152	0,617 0,944 0,555 0,704 0,555 0,450	4,179	0,824 3,491	1,205	4,486	0,620 4,467
QUOTE PROGETTO			658,596 658,294	658,473	658,364	658,307 658,395		
DIST.PARZIALI PROGETTO			0,453 2,322	4,817	4,338	2,312		
QUOTE PAVIMENTATO			658,527 658,727	658,752	658,873	658,764 658,539 658,739		
DIST.PARZIALI PAVIMENTATO			1,010	4,817	4,338	1,000		

SCAVI E BONIFICHE	
STERRO	0,155 m ²
RILEVATI	
RILEVATO	0,793 m ²
TERRENO VEGETALE	4,217 m
SOVRASTRUTTURA STRADALE	
STRATO DI USURA	2,000 m
STRATO DI FONDAZIONE	0,862 m ²

SEZIONE N.: 6
 QT. PROGETTO: 658,845
 DIST.PROG.: 40,000
 DIST.PREC.: 10,000
 DIST.SUCC.: 10,000

SCALA 1:200

QT.RIF. 640,000

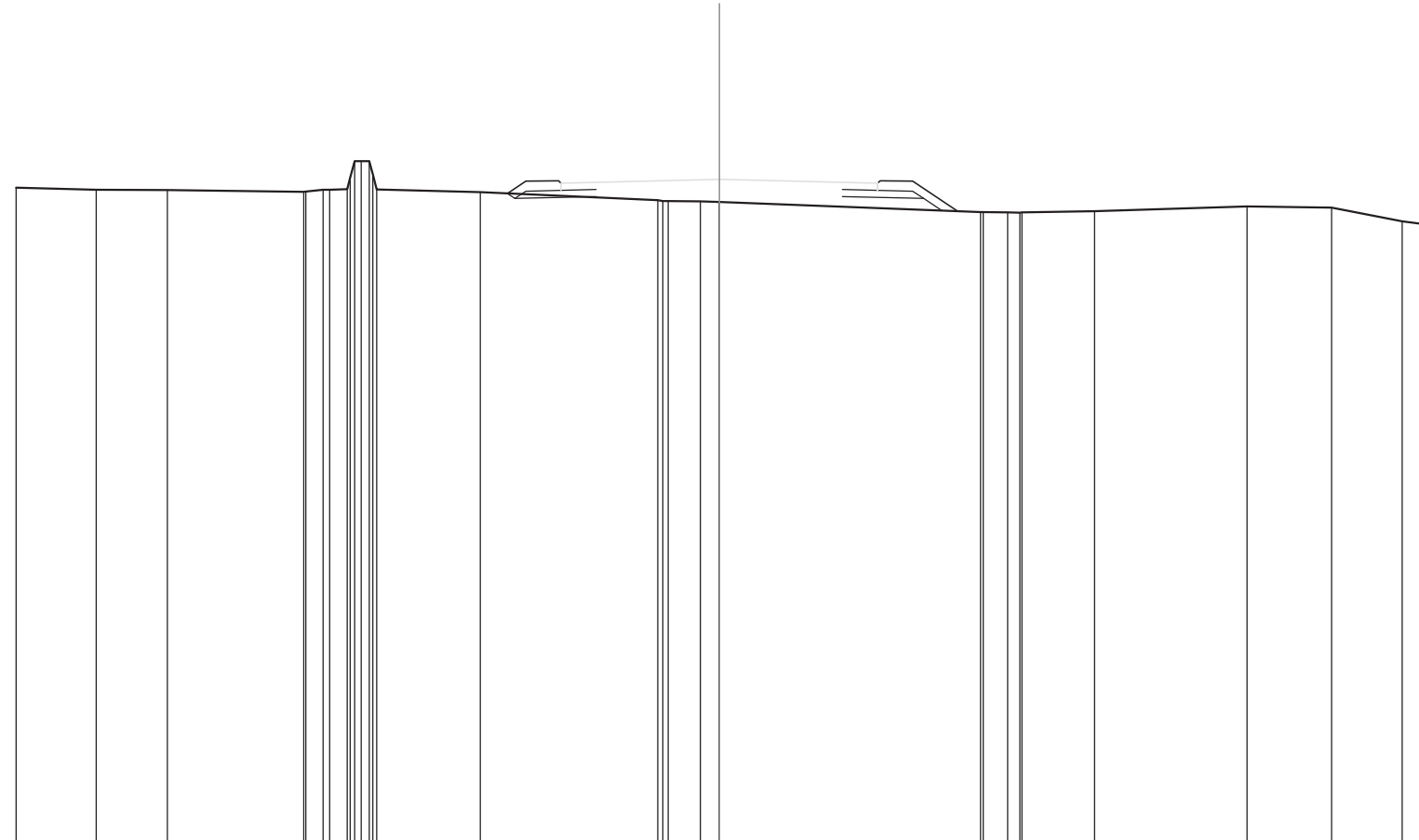

QUOTE TERRENO	658,607	658,547	658,543	658,491 658,488 658,549 658,564 658,900 659,363 659,360 658,989 658,559	658,484	658,256 658,228 658,227 658,223 658,205 658,205	657,915 657,914 657,905 657,900 657,903	657,940	658,073	658,039	657,652 657,572			
DIST.PARZIALI TERRENO	2,281	2,021	3,884	0,492 0,500	2,942	5,052	0,913 0,537	7,424	0,684	2,063	4,339	2,406	2,001	0,588
QUOTE PROGETTO						658,449 658,300	658,357				658,357	658,300 657,957		
DIST.PARZIALI PROGETTO						2,312	7,000	2,312	0,513					
QUOTE PAVIMENTATO						658,732 658,532	658,845	658,532 658,732						
DIST.PARZIALI PAVIMENTATO							4,500	4,500						

V11

Svincolo Campeda al km 152+000

ROTATORIA CAMPEDA

SCAVI E BONIFICHE	
SCOTICO	22,983 m
BONIFICA	4,597 m ²
RILEVATI	
RILEVATO	36,750 m ²
TERRENO VEGETALE	15,766 m
SOVRASTRUTTURA STRADALE	
STRATO DI USURA	8,000 m
STRATO DI FONDAZIONE	2,074 m ²

SEZIONE N.: 1
 QT. PROGETTO: 659,126
 DIST.PROG.: 0,000
 DIST.SUCC.: 1,001

SCALA 1:200

QT.RIF. 645,000

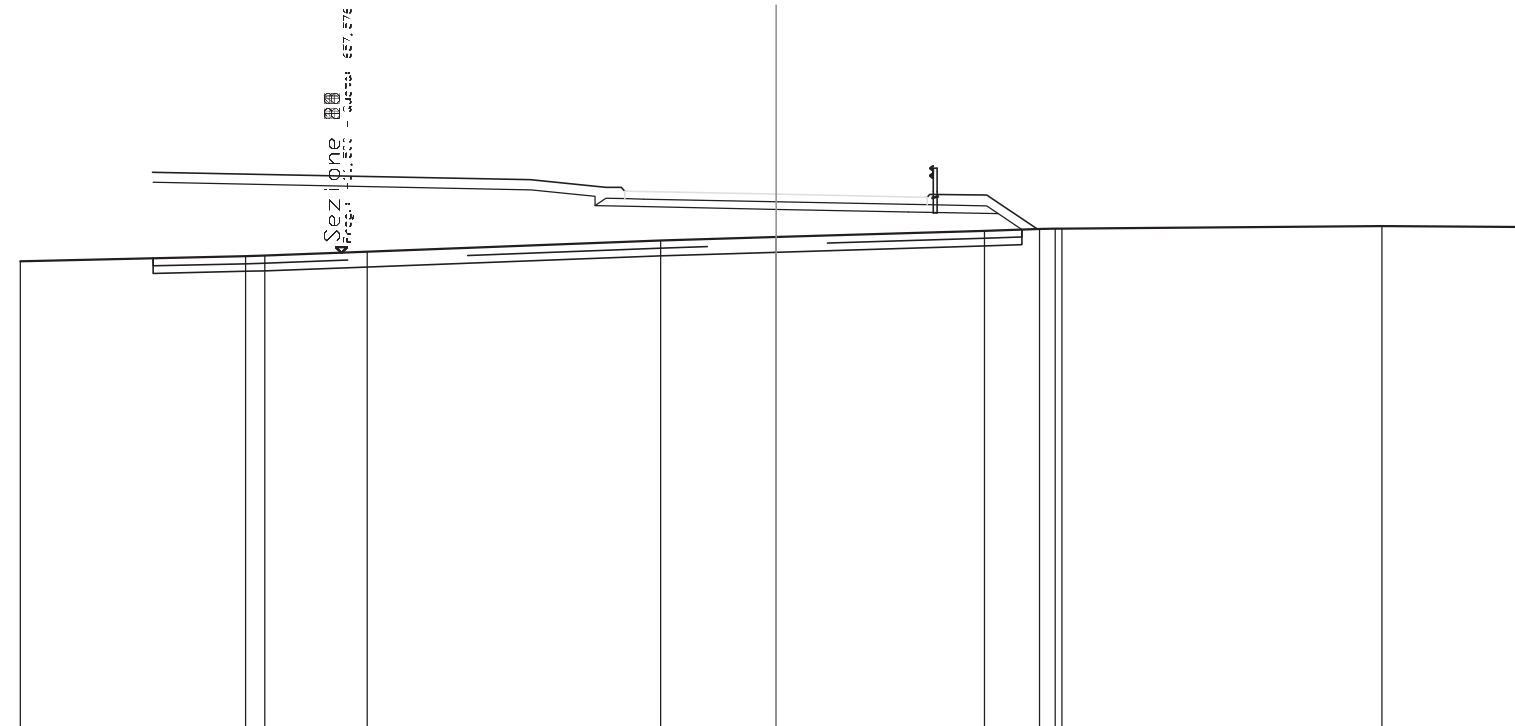

QUOTE TERRENO	657,353	657,486	657,500	657,602	657,898	657,991	658,159	658,208	658,211	658,215	658,278	658,259
DIST.PARZIALI TERRENO	5,966	0,506	2,706	7,763	3,059	5,514	1,456	0,418	8,472	3,967		
QUOTE PROGETTO	659,440	659,240	658,822	659,071	658,796	658,726	658,656	658,609	658,192			
DIST.PARZIALI PROGETTO	10,000	1,688	1,291	3,500	3,500	2,379	0,624					
QUOTE PAVIMENTATO		659,006	659,206	659,196	659,126	659,056	658,846	659,046				
DIST.PARZIALI PAVIMENTATO		0,500	3,500	3,500		0,500						

SCAVI E BONIFICHE	
SCOTICO	22,905 m
BONIFICA	4,581 m ²
RILEVATI	
RILEVATO	36,383 m ²
TERRENO VEGETALE	15,679 m
SOVRASTRUTTURA STRADALE	
STRATO DI USURA	8,000 m
STRATO DI FONDAZIONE	2,074 m ²

SEZIONE N.: 2
 QT. PROGETTO: 659,126
 DIST.PROG.: 1,001
 DIST.PREC.: 1,001
 DIST.SUCC.: 1,742

SCALA 1:200

QT.RIF. 645,000

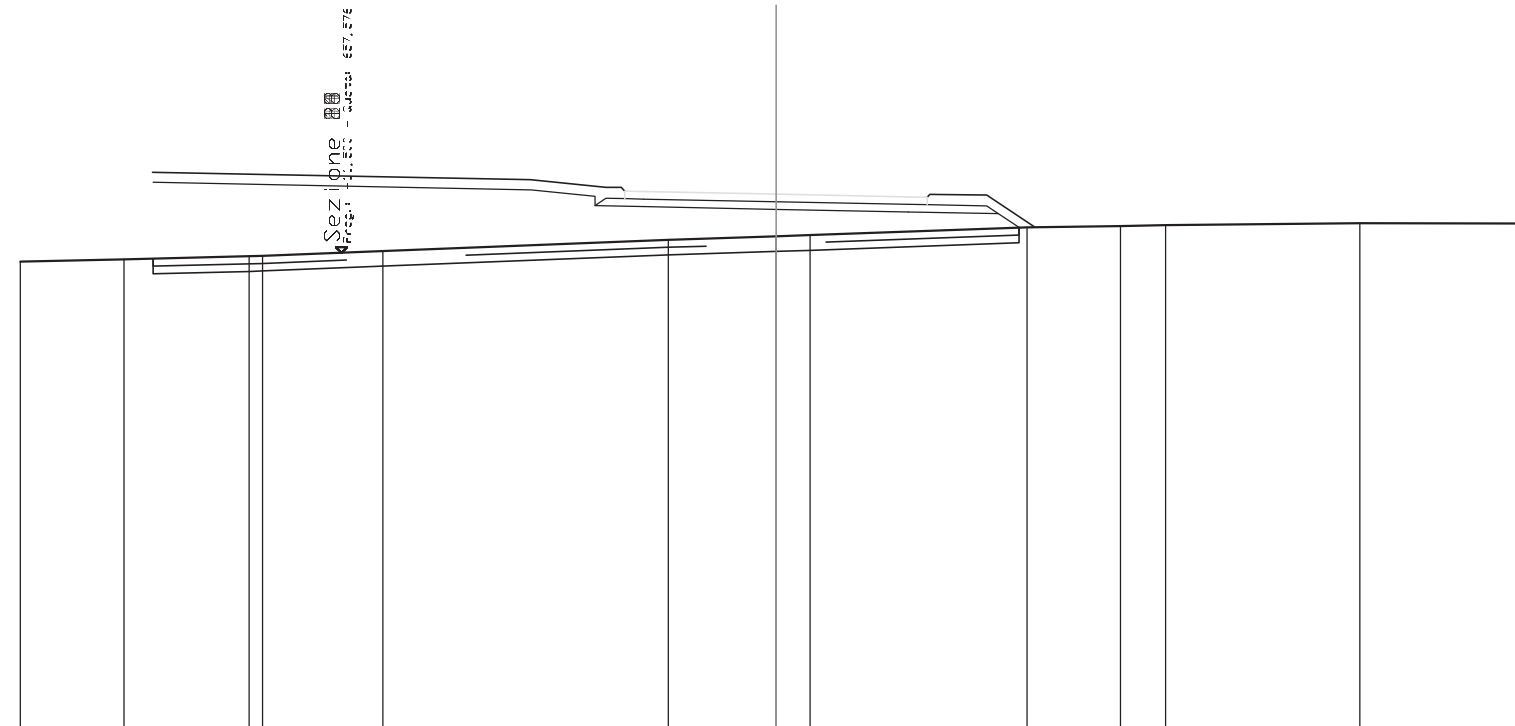

QUOTE TERRENO	657,346	657,403	657,483 657,494	657,620	657,920	658,012 658,041	658,252	658,279 658,306	658,361	658,352	
DIST.PARZIALI TERRENO	2,749	3,309	3,188	7,551	2,849	0,895	5,748	2,469	1,198	5,137	4,554
QUOTE PROGETTO		659,440		659,240	659,822 659,071	659,796	659,726	659,656	659,609 659,244		
DIST.PARZIALI PROGETTO			10,000	1,688	1,291	3,500	3,500	2,379	0,547		
QUOTE PAVIMENTATO					659,006 659,206 659,196		659,126		659,056 659,046 659,046		
DIST.PARZIALI PAVIMENTATO					0,500	3,500	3,500		0,500		

SCAVI E BONIFICHE	
SCOTICO	22,788 m
BONIFICA	4,558 m ²
RILEVATI	
RILEVATO	35,735 m ²
TERRENO VEGETALE	15,540 m
SOVRASTRUTTURA STRADALE	
STRATO DI USURA	8,000 m
STRATO DI FONDAZIONE	2,074 m ²

SEZIONE N.: 3
 QT. PROGETTO: 659,126
 DIST.PROG.: 2,743
 DIST.PREC.: 1,742
 DIST.SUCC.: 2,314

SCALA 1:200

QT.RIF. 645,000

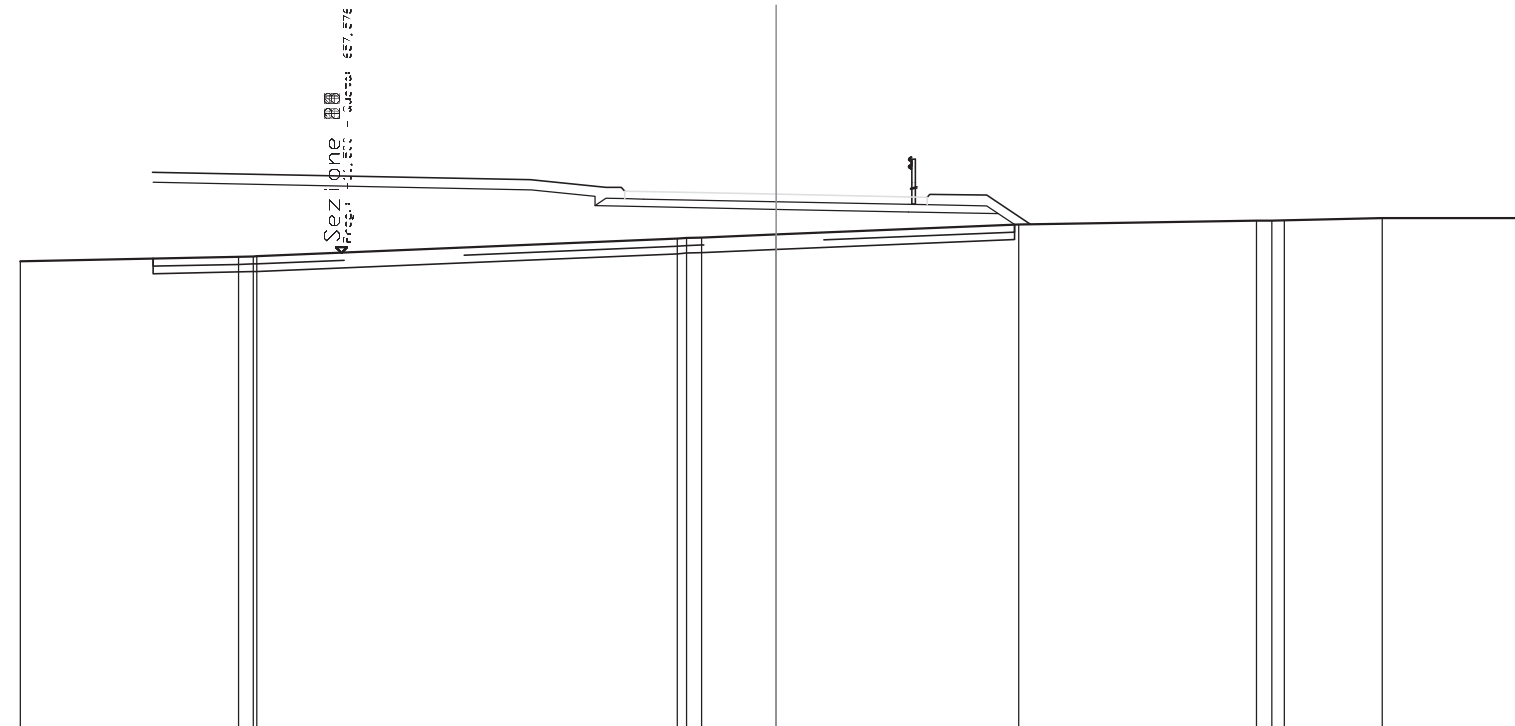

QUOTE TERRENO	657,352	657,469 657,479 657,482	657,949 657,969 657,980	658,062	658,327	658,422 658,426 658,431	658,491	658,492
DIST.PARZIALI TERRENO	5,778	11,130	0,402 1,969	6,416	6,292	0,411 2,595	3,960	
QUOTE PROGETTO	659,440	659,240	658,822 659,071 658,796	658,726	658,656	658,609 658,322		
DIST.PARZIALI PROGETTO	10,000	1,688 1,291	3,500	3,500	2,379	0,430		
QUOTE PAVIMENTATO		659,006 659,206 659,196	659,126	659,056 658,846 659,046				
DIST.PARZIALI PAVIMENTATO		0,500 3,500	3,500	0,500				

SCAVI E BONIFICHE	
SCOTICO	22,671 m
BONIFICA	4,534 m ²
RILEVATI	
RILEVATO	34,946 m ²
TERRENO VEGETALE	15,383 m
SOVRASTRUTTURA STRADALE	
STRATO DI USURA	8,000 m
STRATO DI FONDAZIONE	2,074 m ²

SEZIONE N.: 4
 QT. PROGETTO: 659,126
 DIST.PROG.: 5,057
 DIST.PREC.: 2,314
 DIST.SUCC.: 3,423

SCALA 1:200

QT.RIF. 645,000

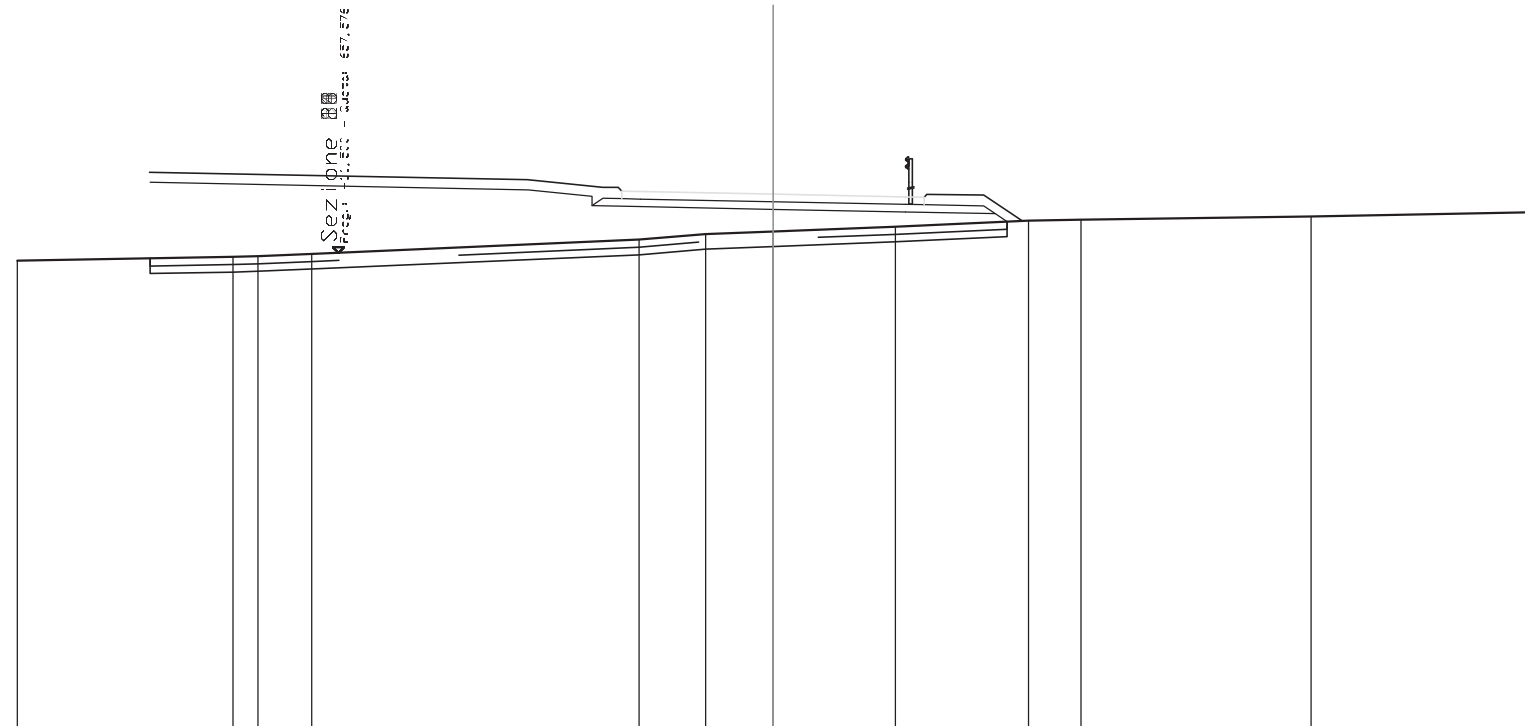

QUOTE TERRENO	657,365	657,466	657,484	657,546	657,923	658,072	658,140	658,264	658,426	658,454	658,539	658,644
DIST.PARZIALI TERRENO	5,707	0,667	1,416	8,665	1,759	1,787	3,237	3,522	1,387	6,091	5,764	
QUOTE PROGETTO	659,440	659,240	658,822	659,071	658,796	658,726	658,656	658,609	658,400			
DIST.PARZIALI PROGETTO	10,000	1,688	1,291	3,500	3,500	2,379						
QUOTE PAVIMENTATO		659,006	659,206	659,196	659,126	659,056	658,846	659,046				
DIST.PARZIALI PAVIMENTATO		0,500	3,500	3,500	0,500							

SCAVI E BONIFICHE	
SCOTICO	22,504 m
BONIFICA	4,501 m ²
RILEVATI	
RILEVATO	33,889 m ²
TERRENO VEGETALE	15,202 m
SOVRASTRUTTURA STRADALE	
STRATO DI USURA	8,000 m
STRATO DI FONDAZIONE	2,074 m ²

SEZIONE N.: 5
 QT. PROGETTO: 659,126
 DIST.PROG.: 8,480
 DIST.PREC.: 3,423
 DIST.SUCC.: 0,911

SCALA 1:200

QT.RIF. 645,000

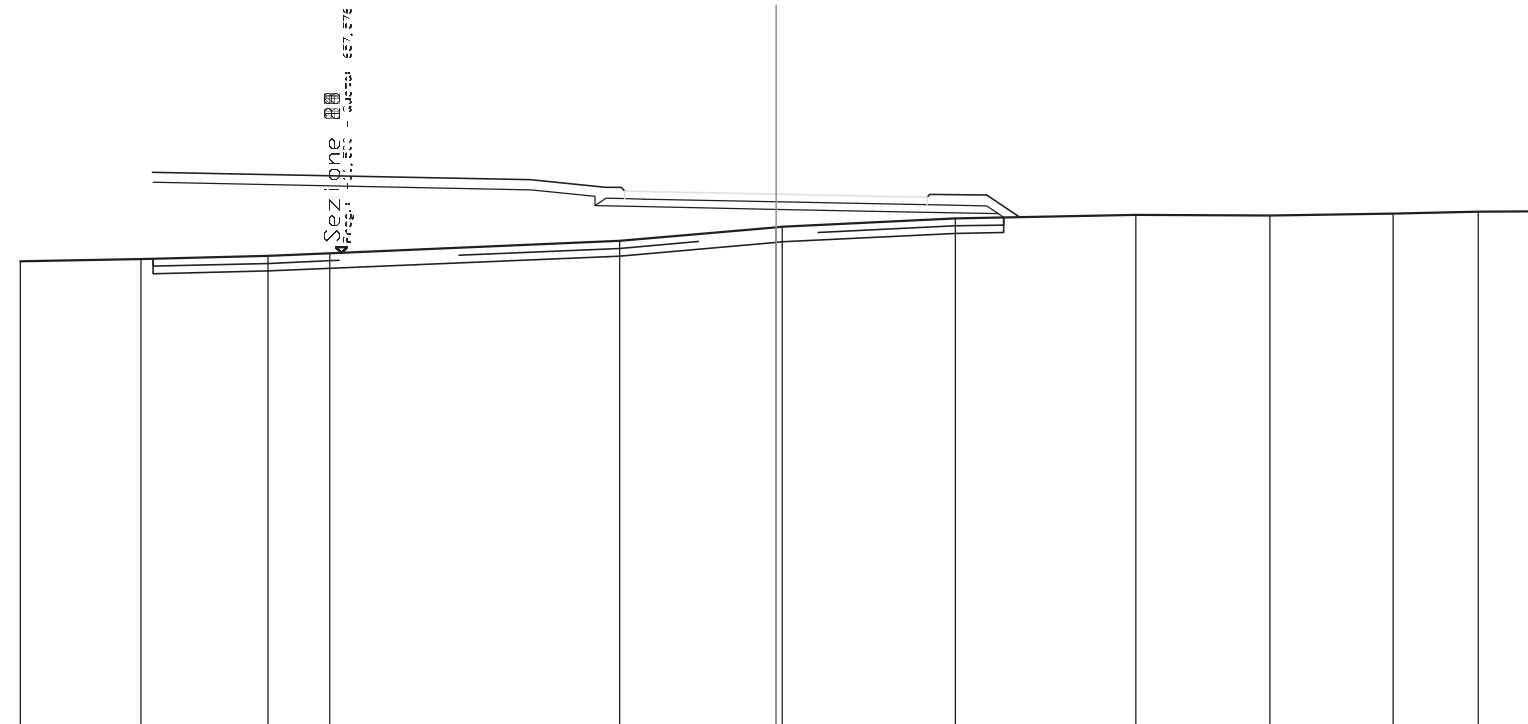

QUOTE TERRENO	657,349	657,412	657,494	657,563	657,890	658,251	658,266	658,488	658,576	658,562	658,614	658,664	658,670
DIST.PARZIALI TERRENO	3,193	3,365	1,633	7,672	4,137	4,581	4,768	3,555	3,255	2,248	1,426		
QUOTE PROGETTO		659,440			659,240	658,822	659,071	658,796	659,726	658,656	658,609	658,511	
DIST.PARZIALI PROGETTO			10,000		1,688	1,291	3,500	3,500	2,379				
QUOTE PAVIMENTATO					659,006	659,206	659,196		659,126	659,056	658,846	659,046	
DIST.PARZIALI PAVIMENTATO					0,500	3,500		3,500	0,500				

SCAVI E BONIFICHE	
SCOTICO	22,501 m
BONIFICA	4,500 m ²
RILEVATI	
RILEVATO	33,815 m ²
TERRENO VEGETALE	15,218 m
SOVRASTRUTTURA STRADALE	
STRATO DI USURA	8,000 m
STRATO DI FONDAZIONE	2,074 m ²

SEZIONE N.: 7
 QT. PROGETTO: 659,126
 DIST.PROG.: 10,448
 DIST.PREC.: 1,057
 DIST.SUCC.: 4,034

SCALA 1:200

QT.RIF. 645,000

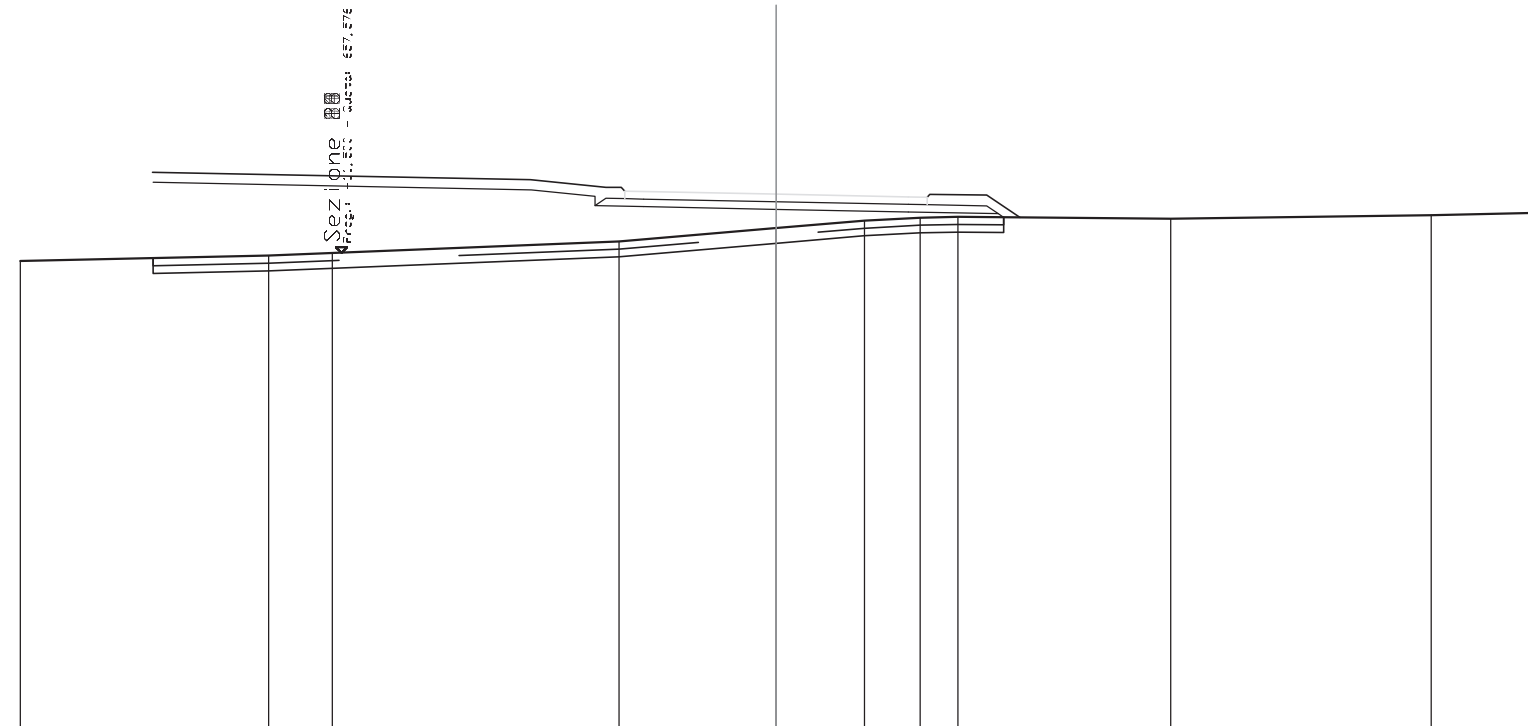

QUOTE TERRENO	657,355	657,500	657,567	657,873	658,227	658,426	658,503	658,524	658,477	658,573	658,626
DIST.PARZIALI TERRENO	6,577	1,683	7,580	4,159	2,336	1,473	1,004	5,632	6,884	2,671	
QUOTE PROGETTO	659,440	659,240	658,822	659,071	658,796	658,726	658,656	658,609	658,514		
DIST.PARZIALI PROGETTO	10,000	1,688	1,291	3,500	3,500	2,379					
QUOTE PAVIMENTATO			659,006	659,206	659,196	659,126	659,056	658,946	659,046		
DIST.PARZIALI PAVIMENTATO			0,500	3,500	3,500	0,500					

SCAVI E BONIFICHE	
SCOTICO	22,898 m
BONIFICA	4,580 m ²
RILEVATI	
RILEVATO	36,812 m ²
TERRENO VEGETALE	21,640 m
SOVRASTRUTTURA STRADALE	
STRATO DI USURA	10,619 m
STRATO DI FONDAZIONE	3,321 m ²

SEZIONE N.: 8
 QT. PROGETTO: 659,126
 DIST.PROG.: 14,482
 DIST.PREC.: 4,034
 DIST.SUCC.: 3,582

SCALA 1:200

QT.RIF. 645,000

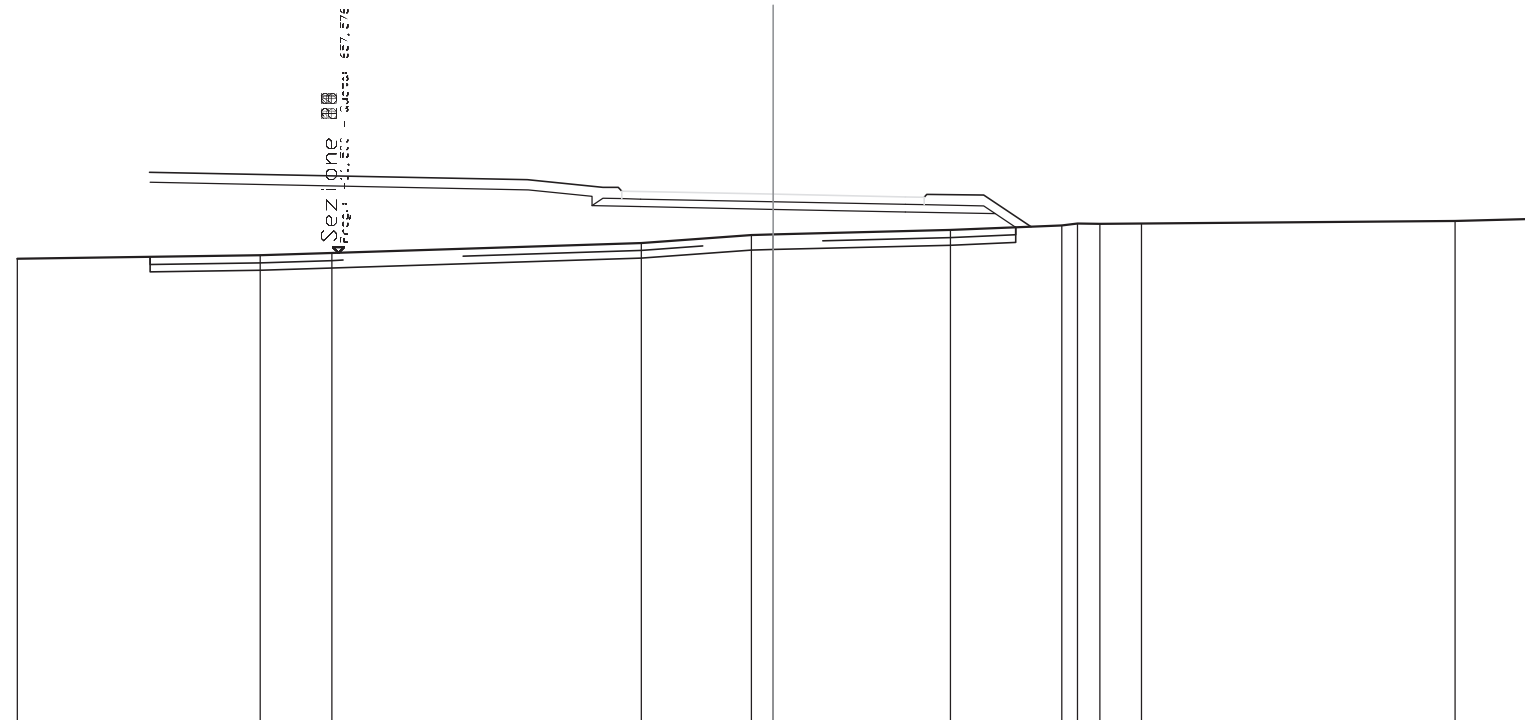

QUOTE TERRENO	657,415	657,511	657,571		657,834	658,047	658,061		658,177	658,300	658,349	658,340	658,352		658,420	658,464
DIST.PARZIALI TERRENO	6,432	1,892		8,192	2,908	0,576		4,693	2,947	0,413	0,586	1,100		8,297	1,954	
QUOTE PROGETTO	659,440			659,240	658,822	659,071	658,796	658,726	658,656	658,609	658,249					
DIST.PARZIALI PROGETTO		10,000		1,688	1,291	3,500	3,500	2,379	0,539							
QUOTE PAVIMENTATO				659,006	659,206	659,196		659,126	659,056	658,846	659,046					
DIST.PARZIALI PAVIMENTATO				0,500	3,500		3,500	0,500								

SCAVI E BONIFICHE	
SCOTICO	24,426 m
BONIFICA	4,885 m ²
RILEVATI	
RILEVATO	45,566 m ²
TERRENO VEGETALE	32,905 m
SOVRASTRUTTURA STRADALE	
STRATO DI USURA	8,000 m
STRATO DI FONDAZIONE	2,074 m ²

SEZIONE N.: 15
 QT. PROGETTO: 659,126
 DIST.PROG.: 31,469
 DIST.PREC.: 5,789
 DIST.SUCC.: 2,406

SCALA 1:200

QT.RIF. 645,000

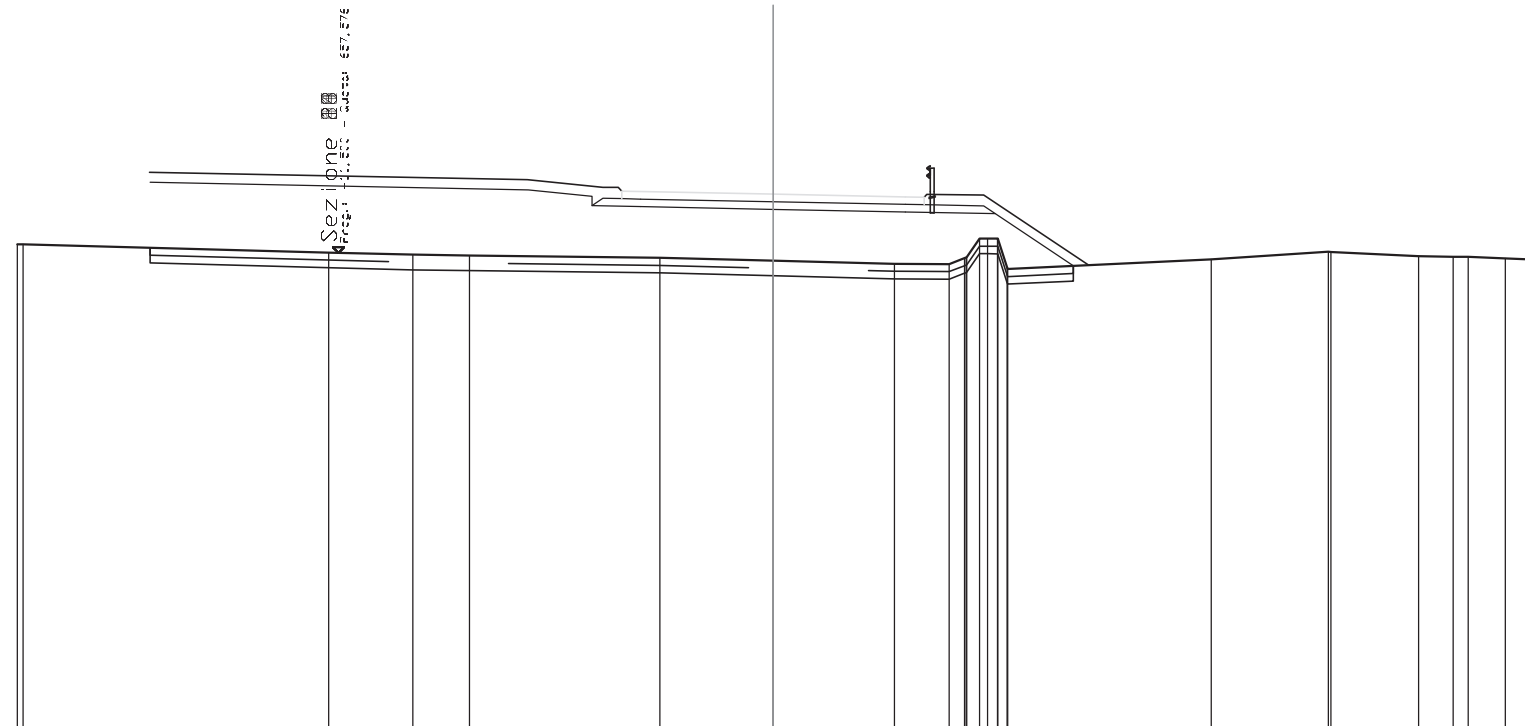

QUOTE TERRENO	657,803 657,800		657,583	657,525	657,502		657,444	657,368	657,287	657,277 657,435 657,450 657,461 657,951 657,950 657,948 657,947 657,187 657,146	657,404	657,603 657,600	657,486 657,472 657,467	657,427 657,397	
DIST.PARZIALI TERRENO		8,088	2,223	1,502	5,036		2,996	3,213	1,450	0,406		5,384	3,106	2,313	0,914 0,405 0,981 0,625
QUOTE PROGETTO		659,440			659,240		658,822 659,071	658,796	658,726	658,656	658,609	657,230			
DIST.PARZIALI PROGETTO			10,000		1,688	1,291	3,500	3,500	2,379	2,068					
QUOTE PAVIMENTATO					659,006 659,206 659,196		659,126		659,056 658,846 659,046						
DIST.PARZIALI PAVIMENTATO					0,500	3,500	3,500		0,500						

SCAVI E BONIFICHE	
SCOTICO	24,485 m
BONIFICA	4,897 m ²
RILEVATI	
RILEVATO	46,773 m ²
TERRENO VEGETALE	38,202 m
SOVRASTRUTTURA STRADALE	
STRATO DI USURA	8,000 m
STRATO DI FONDAZIONE	2,074 m ²

SEZIONE N.: 16
 QT. PROGETTO: 659,126
 DIST.PROG.: 33,875
 DIST.PREC.: 2,406
 DIST.SUCC.: 2,051

SCALA 1:200

QT.RIF. 645,000

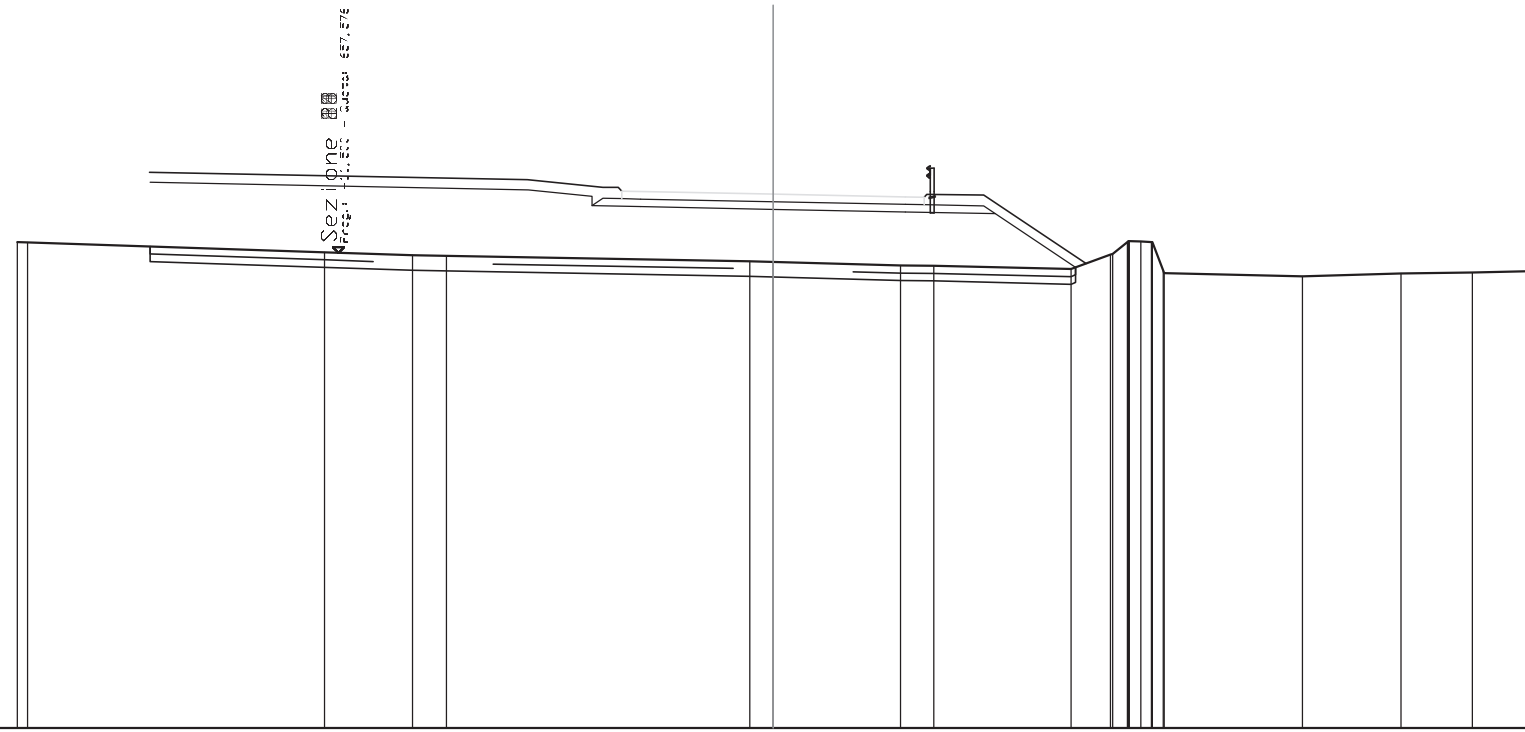

QUOTE TERRENO	657,857 657,850		657,589	657,512 657,493		657,352 657,335	657,240 657,231	657,145	657,531 657,529 657,528 657,527 657,526 657,525 657,524 657,523 657,522 657,521 657,520 657,519 657,518 657,517 657,516 657,515 657,514 657,513 657,512 657,511 657,510 657,509 657,508 657,507 657,506 657,505 657,504 657,503	656,953	657,025	657,056	657,089		
DIST.PARZIALI TERRENO		7,852	2,327	0,898	8,027	0,618	3,376	0,874	3,632	1,040	0,393	3,657	2,609	1,885	1,498
QUOTE PROGETTO		659,440			659,240	658,822 659,071	658,726	658,656	658,609	657,191					
DIST.PARZIALI PROGETTO			10,000		1,688	1,291	3,500	3,500	2,379	2,126					
QUOTE PAVIMENTATO					659,006 659,206 659,196		659,126	659,056 658,846 659,046							
DIST.PARZIALI PAVIMENTATO					0,500	3,500	3,500	0,500							

SCAVI E BONIFICHE	
SCOTICO	24,593 m
BONIFICA	4,919 m ²
RILEVATI	
RILEVATO	47,304 m ²
TERRENO VEGETALE	17,743 m
SOVRASTRUTTURA STRADALE	
STRATO DI USURA	8,000 m
STRATO DI FONDAZIONE	2,074 m ²

SEZIONE N.: 17
 QT. PROGETTO: 659,126
 DIST.PROG.: 35,926
 DIST.PREC.: 2,051
 DIST.SUCC.: 0,202

SCALA 1:200

QT.RIF. 640,000

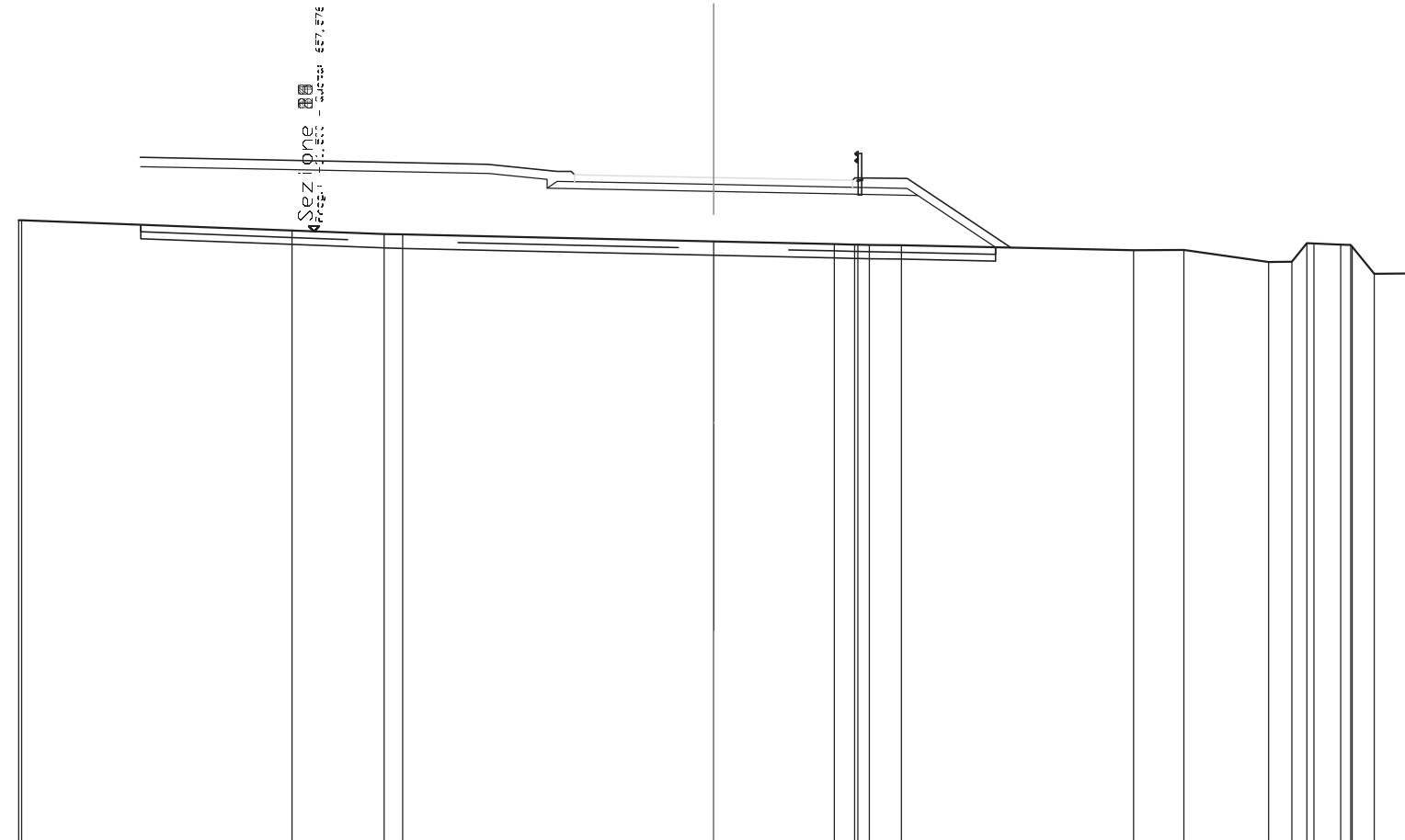

QUOTE TERRENO	657,886 657,894	657,600	657,501 657,487	657,291	657,214 657,197 657,196 657,187	657,176	657,035	657,044	656,691 656,700 657,236 657,227	657,191 657,182 657,132 656,359	656,362
DIST.PARZIALI TERRENO	7,778	2,648	0,538	8,944	3,475	0,585 0,924	6,685	1,448	2,433	0,669 0,431 0,771	0,635 0,993
QUOTE PROGETTO	659,440	659,240	658,822 659,071	658,796	658,726	658,656	658,609	657,118			
DIST.PARZIALI PROGETTO	10,000	1,688	1,291	3,500	3,500	2,379	2,234				
QUOTE PAVIMENTATO			659,006 659,206 659,196	659,126		659,056 658,846 659,046					
DIST.PARZIALI PAVIMENTATO			0,500	3,500	3,500	0,500					

SCAVI E BONIFICHE	
SCOTICO	24,609 m
BONIFICA	4,922 m ²
RILEVATI	
RILEVATO	47,385 m ²
TERRENO VEGETALE	17,763 m
SOVRASTRUTTURA STRADALE	
STRATO DI USURA	8,000 m
STRATO DI FONDAZIONE	2,074 m ²

SEZIONE N.: 18
 QT. PROGETTO: 659,126
 DIST.PROG.: 36,128
 DIST.PREC.: 0,202
 DIST.SUCC.: 2,257

SCALA 1:200

QT.RIF. 640,000

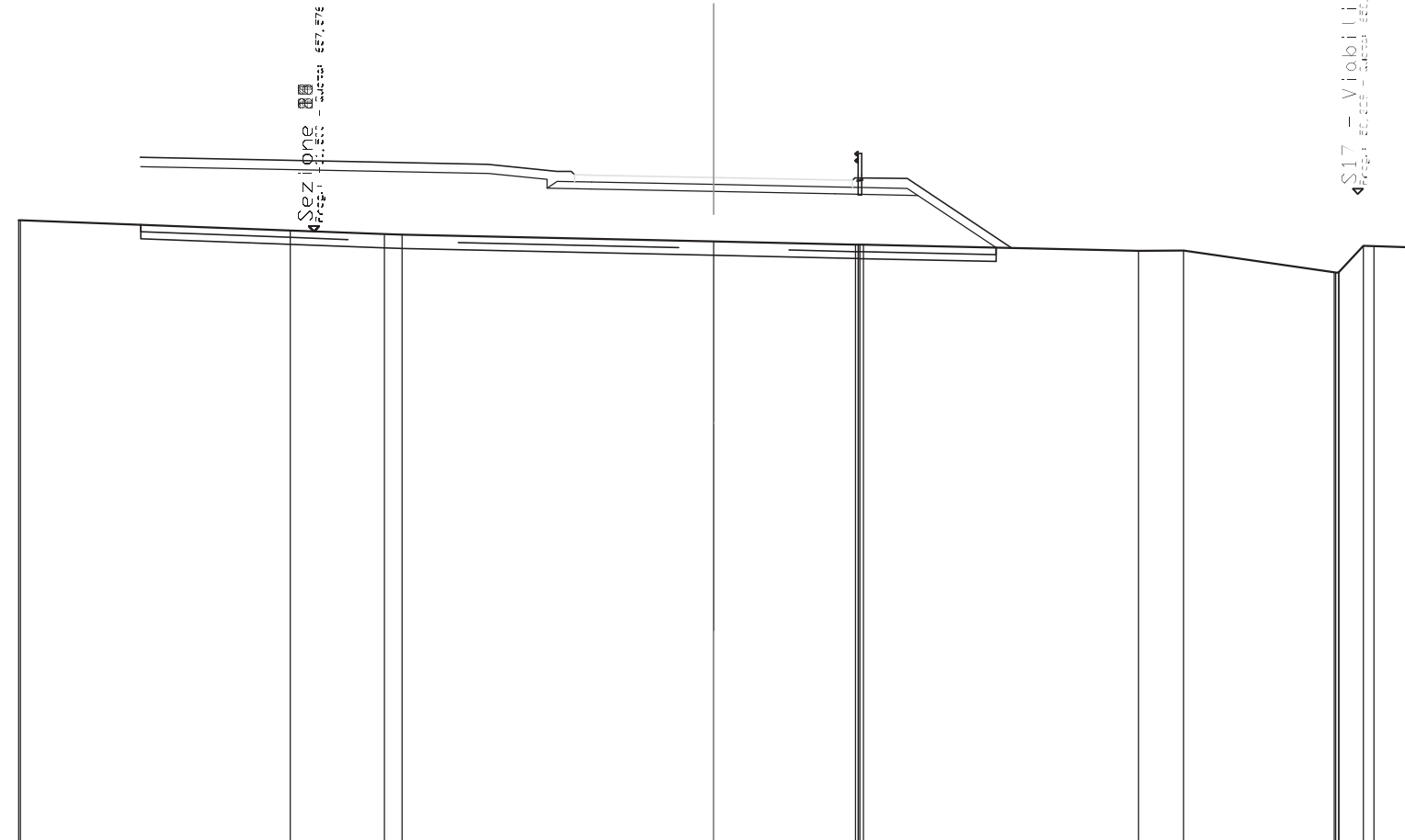

QUOTE TERRENO	657,900 657,898	657,602	657,500 657,486	657,286	657,195 657,193 657,192 657,191 657,190	657,019	657,026	656,305 656,302 656,300 656,300 656,404 657,164 657,154 657,120	
DIST.PARZIALI TERRENO	7,763	2,706	0,506	8,966	4,083	7,916	1,293	4,336	
QUOTE PROGETTO	659,440			659,240	658,822 659,071	658,726	658,656	658,609	657,108
DIST.PARZIALI PROGETTO		10,000		1,688	1,291	3,500	3,500	2,379	2,250
QUOTE PAVIMENTATO					659,006 659,206 659,196	659,126	659,056 658,846 659,046		
DIST.PARZIALI PAVIMENTATO					0,500	3,500	3,500	0,500	

SCAVI E BONIFICHE	
SCOTICO	24,649 m
BONIFICA	4,930 m ²
RILEVATI	
RILEVATO	47,415 m ²
TERRENO VEGETALE	26,660 m
SOVRASTRUTTURA STRADALE	
STRATO DI USURA	8,000 m
STRATO DI FONDAZIONE	2,074 m ²

SEZIONE N.: 19
 QT. PROGETTO: 659,126
 DIST.PROG.: 38,385
 DIST.PREC.: 2,257
 DIST.SUCC.: 10,621

SCALA 1:200

QT.RIF. 645,000

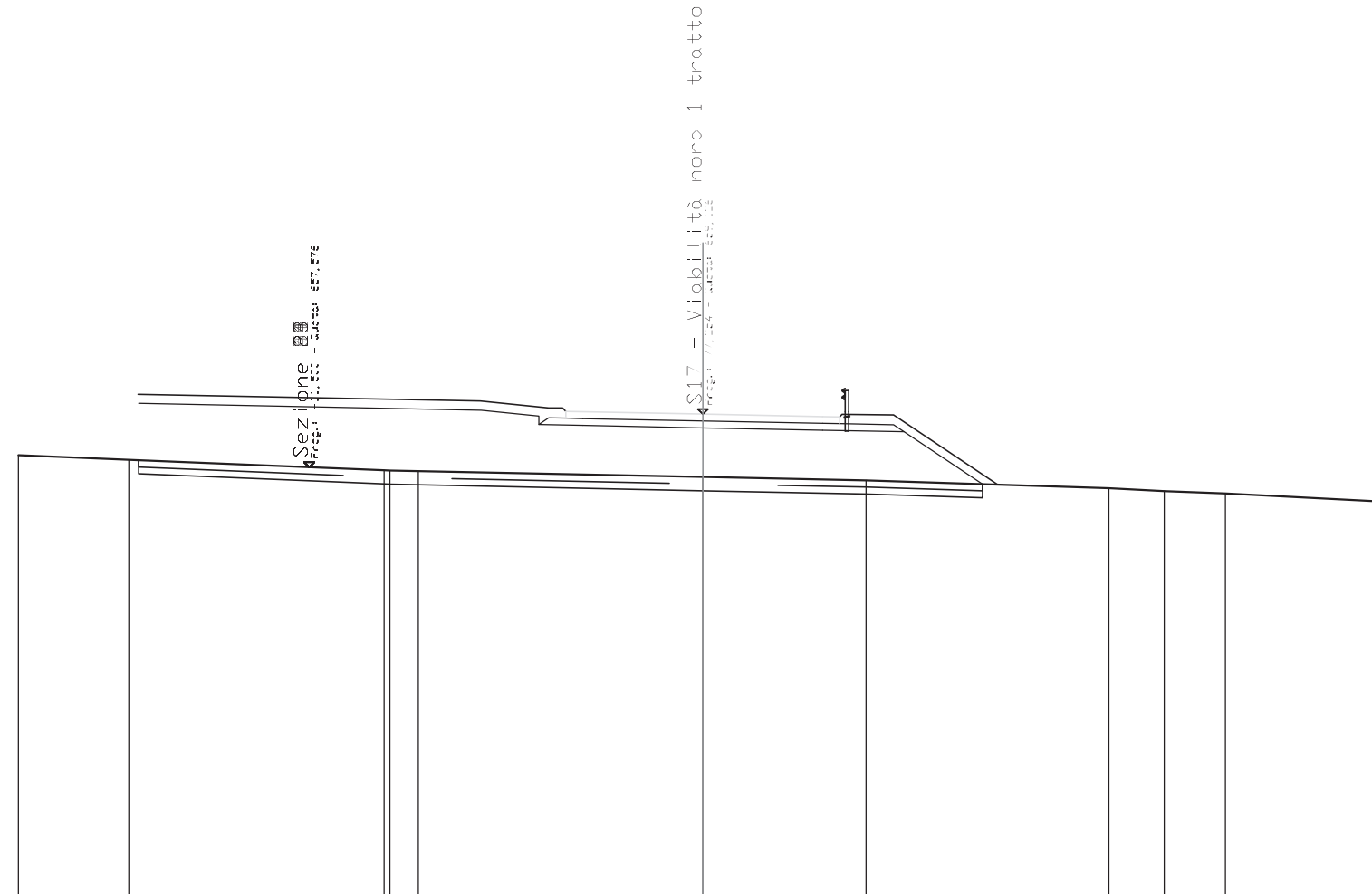

QUOTE TERRENO	657,929	657,795	657,486 657,480 657,459	657,288	657,191	656,961	656,879	656,810	656,563
DIST.PARZIALI TERRENO	3,232	7,460	0,824	8,317	4,765	7,101	1,612	1,794	4,729
QUOTE PROGETTO	659,440	659,240	658,822 659,071 658,796	658,726	658,656	658,609	657,081		
DIST.PARZIALI PROGETTO	10,000	1,688	1,291	3,500	3,500	2,379	2,291		
QUOTE PAVIMENTATO			659,006 659,206 659,196	659,126	659,056 658,846 659,046				
DIST.PARZIALI PAVIMENTATO			0,500	3,500	3,500	0,500			

SCAVI E BONIFICHE	
SCOTICO	24,640 m
BONIFICA	4,928 m ²
RILEVATI	
RILEVATO	47,096 m ²
TERRENO VEGETALE	17,810 m
SOVRASTRUTTURA STRADALE	
STRATO DI USURA	8,000 m
STRATO DI FONDAZIONE	2,074 m ²

SEZIONE N.: 20
 QT. PROGETTO: 659,126
 DIST.PROG.: 49,006
 DIST.PREC.: 10,621
 DIST.SUCC.: 3,765

SCALA 1:200

QT.RIF. 645,000

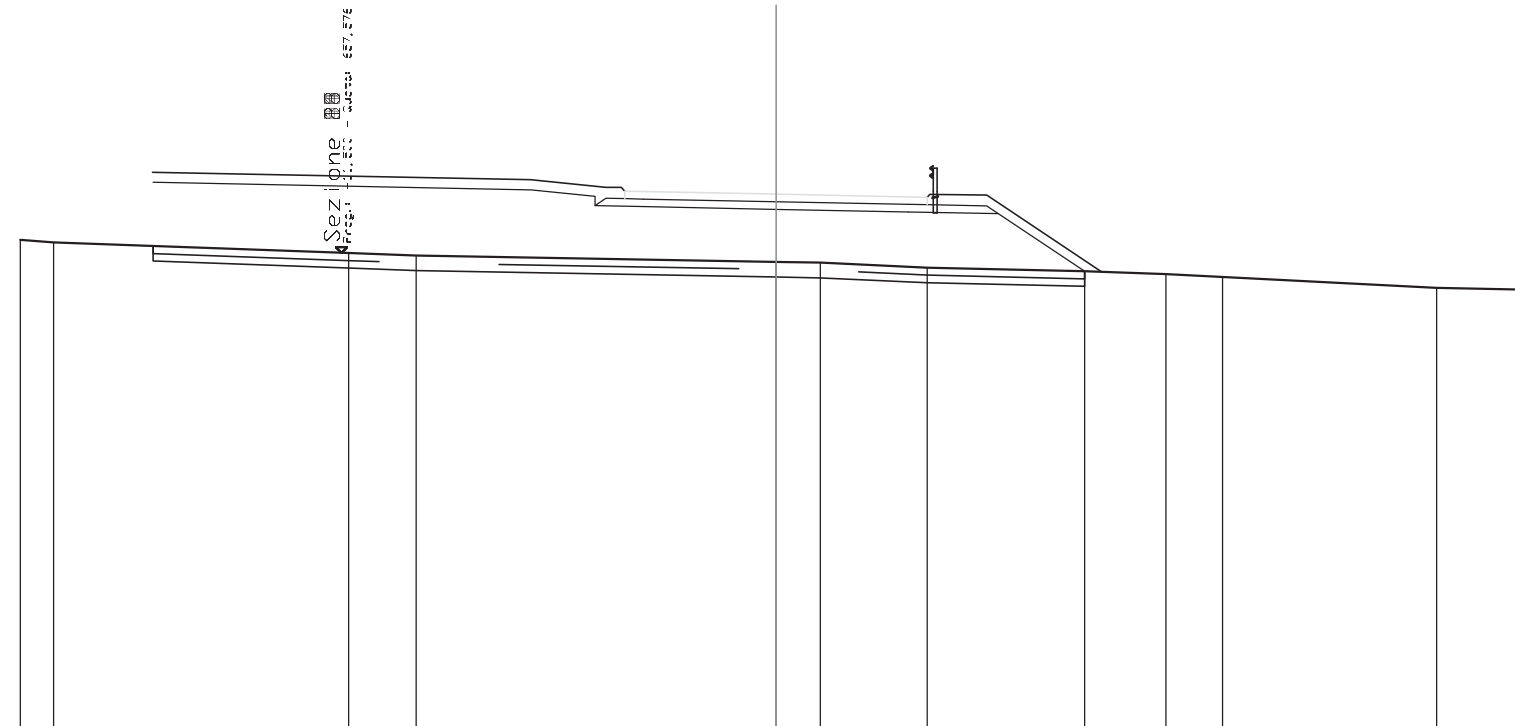

QUOTE TERRENO	657,920	657,850		657,569	657,506		657,335	657,314	657,185	657,087	657,015	656,932	656,648	656,593			
DIST.PARZIALI TERRENO	0,881		7,813		1,784		9,522		1,169		2,825		4,167	2,151	1,498	5,664	2,526
QUOTE PROGETTO			659,440				659,240	658,822	659,071	658,796	658,726	658,656	658,609	657,087			
DIST.PARZIALI PROGETTO					10,000		1,688	1,291	3,500	3,500	2,379	2,281					
QUOTE PAVIMENTATO							659,006	659,206	659,196	659,126	659,056	658,846	659,046				
DIST.PARZIALI PAVIMENTATO							0,500	3,500		3,500	0,500						

SCAVI E BONIFICHE	
SCOTICO	24,656 m
BONIFICA	4,931 m ²
RILEVATI	
RILEVATO	46,676 m ²
TERRENO VEGETALE	17,820 m
SOVRASTRUTTURA STRADALE	
STRATO DI USURA	8,000 m
STRATO DI FONDAZIONE	2,074 m ²

SEZIONE N.: 21
 QT. PROGETTO: 659,126
 DIST.PROG.: 52,771
 DIST.PREC.: 3,765
 DIST.SUCC.: 1,421

SCALA 1:200

QT.RIF. 645,000

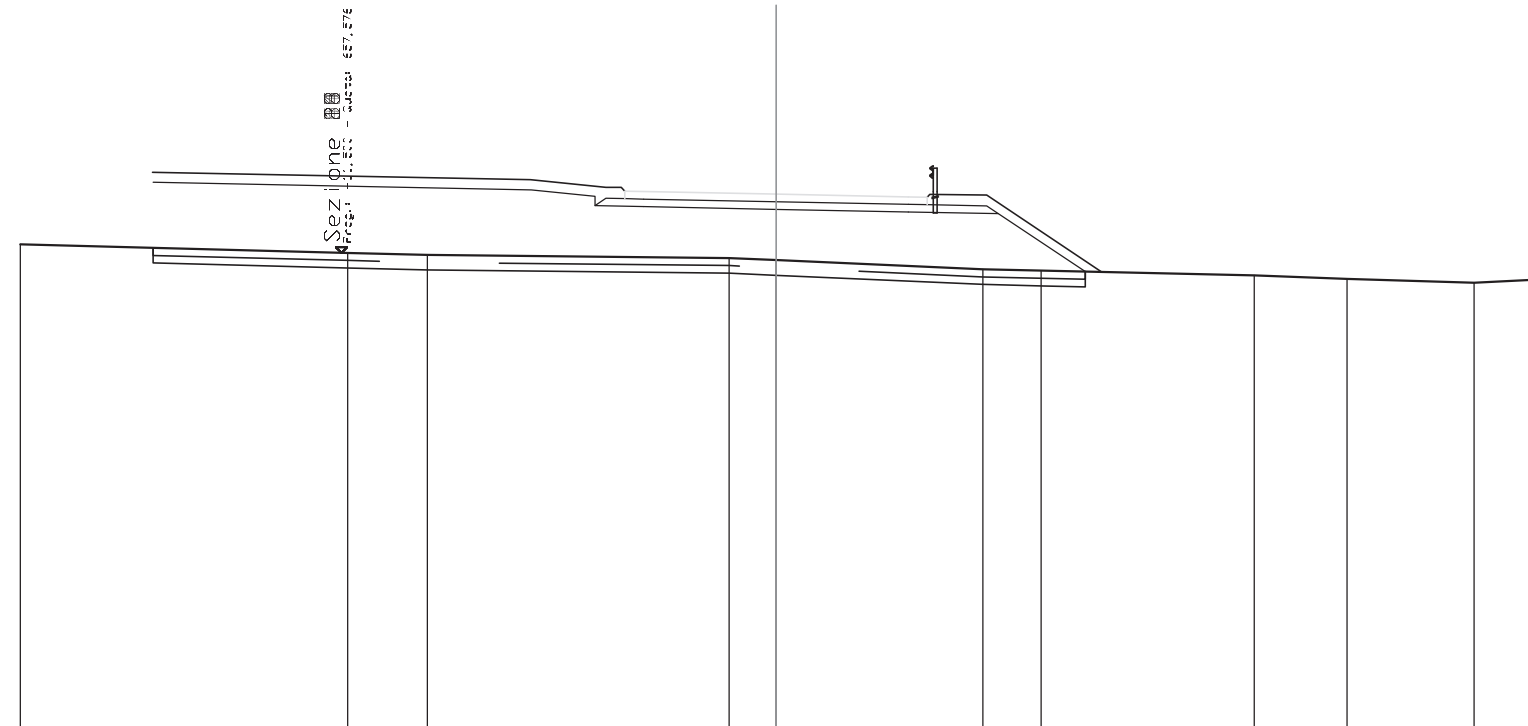

QUOTE TERRENO	657,798	657,572	657,519	657,436	657,381	657,139	657,102	656,978	656,884	656,784	656,862
DIST.PARZIALI TERRENO	8,661	2,116	7,978	1,246	5,474	1,540	5,636	2,455	3,362	1,532	
QUOTE PROGETTO	659,440	659,240	658,822	659,071	658,796	658,726	658,656	658,609	657,076		
DIST.PARZIALI PROGETTO	10,000	1,688	1,291	3,500	3,500	2,379	2,298				
QUOTE PAVIMENTATO		659,006	659,206	659,196	659,126	659,056	658,846	659,046			
DIST.PARZIALI PAVIMENTATO		0,500	3,500	3,500	0,500						

SCAVI E BONIFICHE	
SCOTICO	24,605 m
BONIFICA	4,921 m ²
RILEVATI	
RILEVATO	46,311 m ²
TERRENO VEGETALE	17,756 m
SOVRASTRUTTURA STRADALE	
STRATO DI USURA	8,000 m
STRATO DI FONDAZIONE	2,074 m ²

SEZIONE N.: 22
 QT. PROGETTO: 659,126
 DIST.PROG.: 54,192
 DIST.PREC.: 1,421
 DIST.SUCC.: 5,808

SCALA 1:200

QT.RIF. 645,000

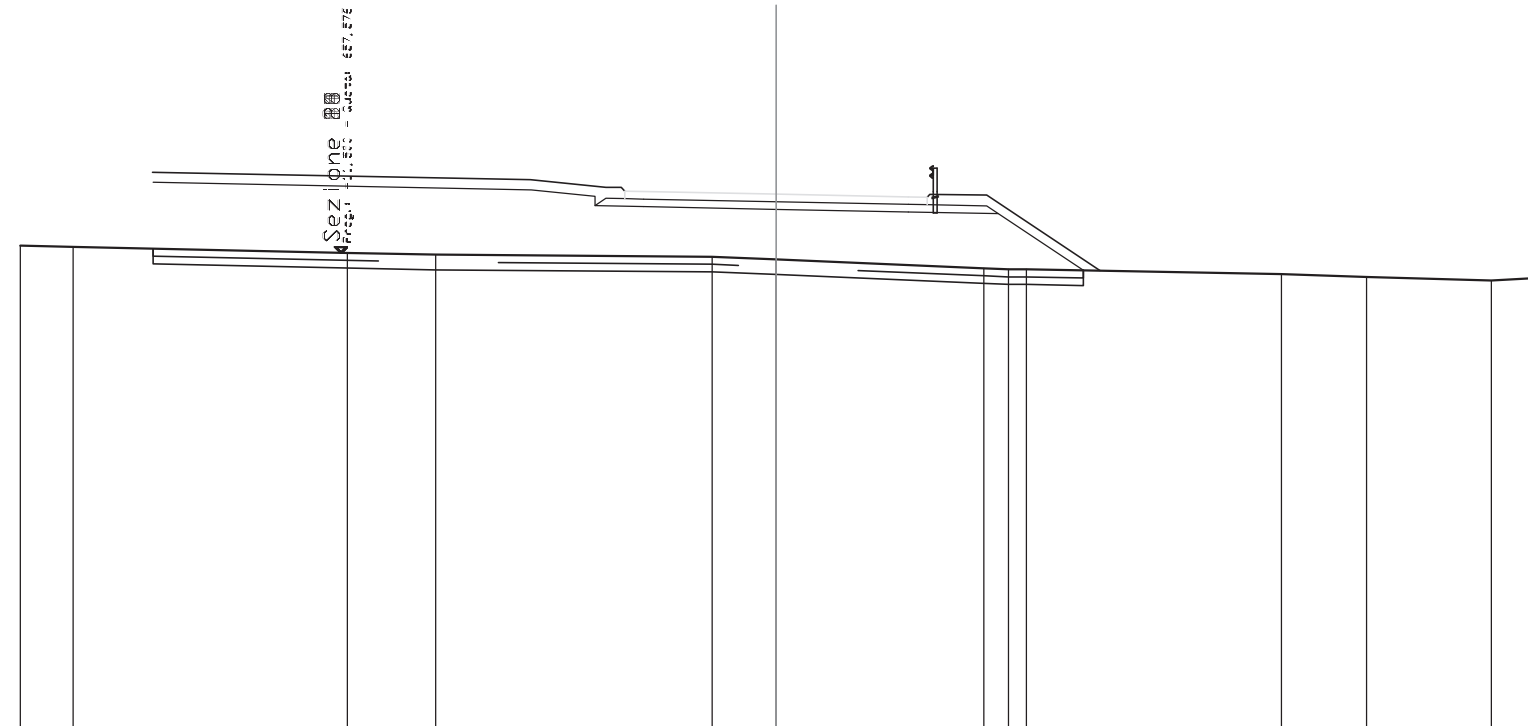

QUOTE TERRENO	657,764	657,730		657,573	657,524		657,473	657,401		657,167	657,140	657,139		657,010	656,934		656,845	656,901		
DIST.PARZIALI TERRENO	1,400		7,255		2,336		7,321		1,688		5,497	0,649	0,474		6,754		2,249		3,299	1,078
QUOTE PROGETTO			659,440				659,240	658,822	659,071	658,796		658,726		658,656	658,609		657,110			
DIST.PARZIALI PROGETTO					10,000		1,688	1,291		3,500		3,500		2,379	2,247					
QUOTE PAVIMENTATO							659,006	659,206	659,196		659,126		659,056	658,846	659,046					
DIST.PARZIALI PAVIMENTATO							0,500		3,500		3,500		0,500							

SCAVI E BONIFICHE	
SCOTICO	24,185 m
BONIFICA	4,837 m ²
RILEVATI	
RILEVATO	43,791 m ²
TERRENO VEGETALE	17,227 m
SOVRASTRUTTURA STRADALE	
STRATO DI USURA	8,000 m
STRATO DI FONDAZIONE	2,074 m ²

SEZIONE N.: 23
 QT. PROGETTO: 659,126
 DIST.PROG.: 60,000
 DIST.PREC.: 5,808
 DIST.SUCC.: 3,395

SCALA 1:200

QT.RIF. 645,000

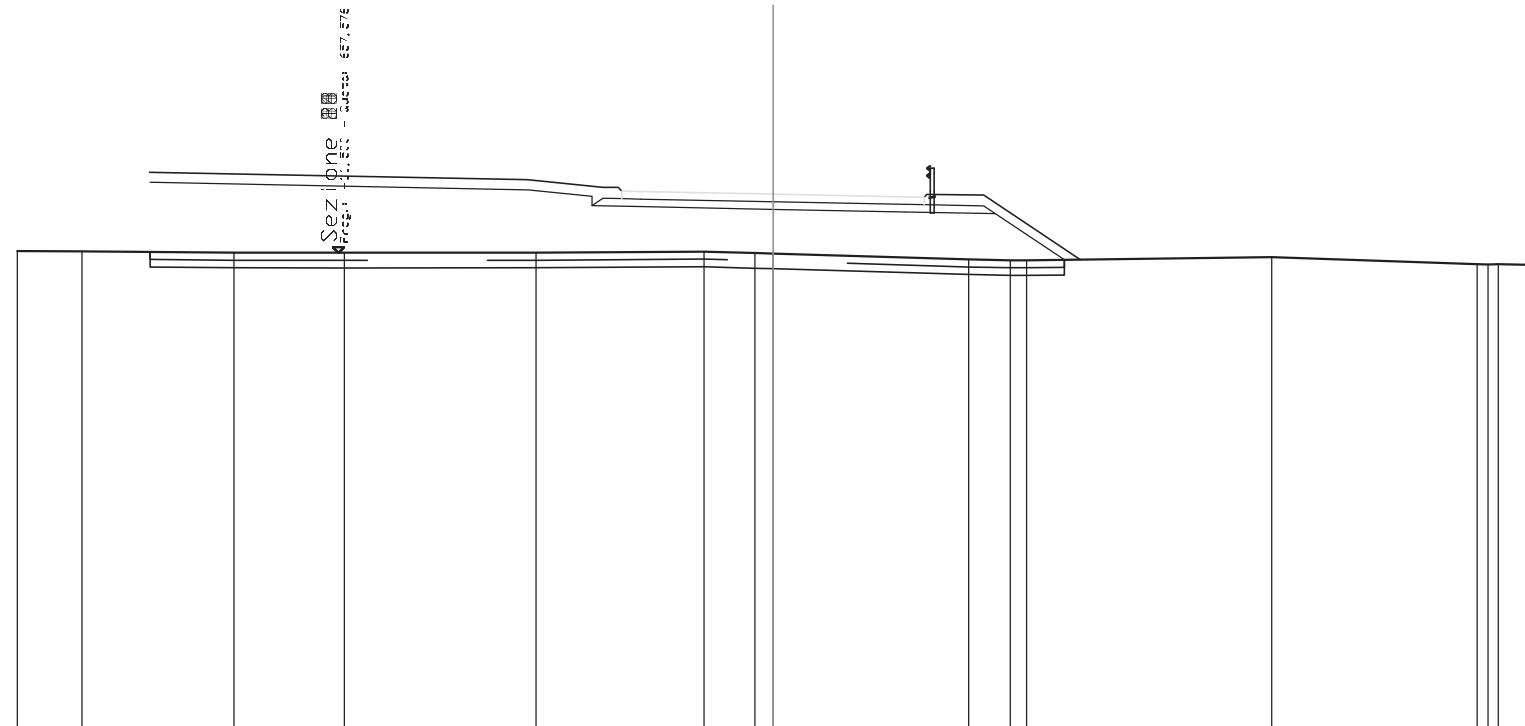

QUOTE TERRENO	657,617	657,613	657,578	657,576	657,577	657,607	657,568	657,554	657,402	657,380	657,378	657,458	657,276	657,267	657,270	657,260
DIST.PARZIALI TERRENO	1,717	4,019	2,921	5,071	4,443	1,346	0,482	5,174	1,106	0,432	6,480	5,434	0,810	0,810	0,810	0,810
QUOTE PROGETTO		659,440			659,240	658,822	659,071	658,796	658,726	658,656	658,609	657,390				
DIST.PARZIALI PROGETTO			10,000		1,688	1,291	3,500	3,500	2,379	1,827						
QUOTE PAVIMENTATO						659,006	659,206	659,196	659,126	659,056	658,846	659,046				
DIST.PARZIALI PAVIMENTATO						0,500	3,500	3,500	0,500							

SCAVI E BONIFICHE	
SCOTICO	23,670 m
BONIFICA	4,734 m ²
RILEVATI	
RILEVATO	40,994 m ²
TERRENO VEGETALE	16,618 m
SOVRASTRUTTURA STRADALE	
STRATO DI USURA	8,000 m
STRATO DI FONDAZIONE	2,074 m ²

SEZIONE N.: 24
 QT. PROGETTO: 659,126
 DIST.PROG.: 63,395
 DIST.PREC.: 3,395
 DIST.SUCC.: 2,599

SCALA 1:200

QT.RIF. 645,000

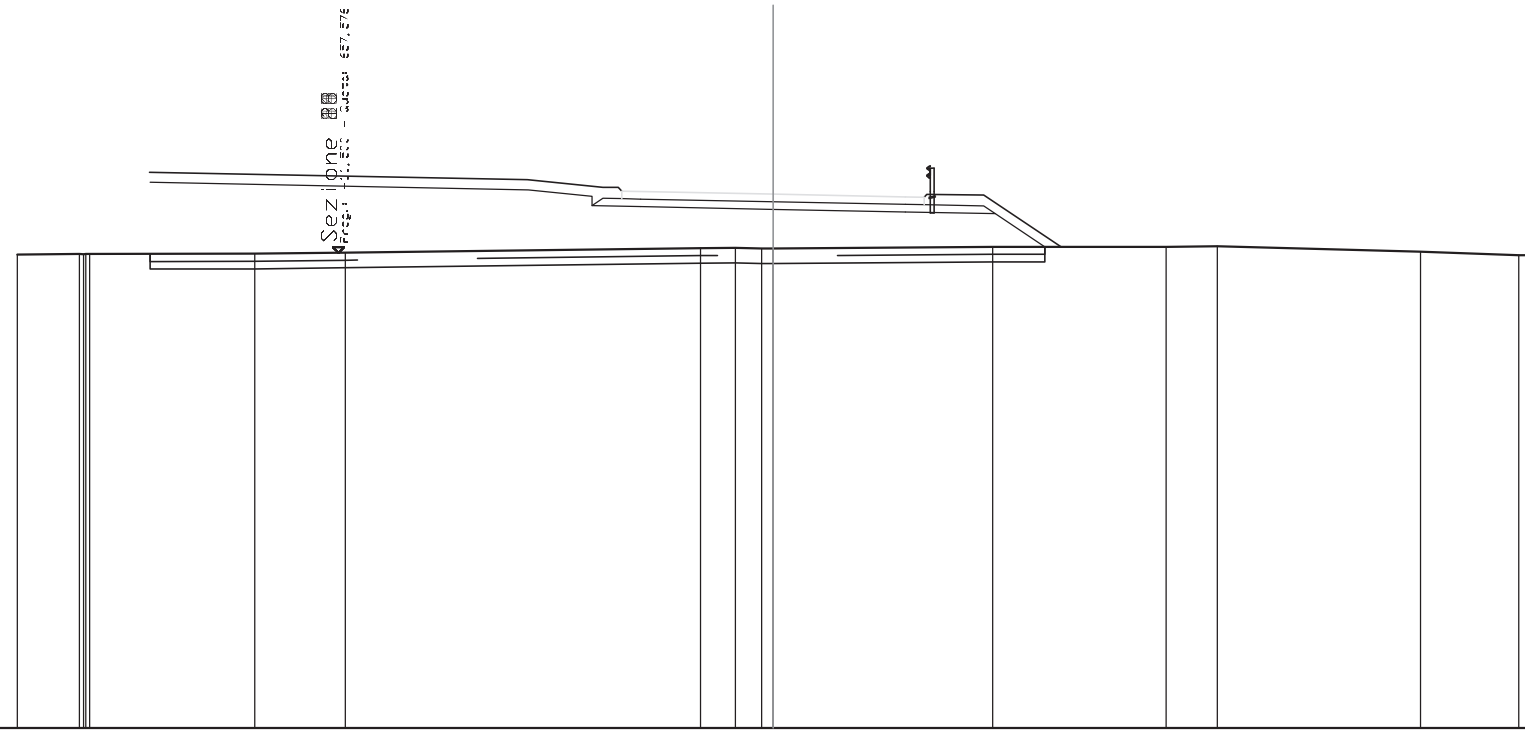

QUOTE TERRENO	657,531	657,541 657,540 657,541 657,541	657,549	657,579		657,699	657,705	657,688 657,690	657,734	657,732	657,750	657,608	657,513 657,513
DIST.PARZIALI TERRENO	1,644	4,373	2,393	9,400		0,922	0,693	5,812	4,588	1,356	5,372	2,603	
QUOTE PROGETTO		659,440			659,240	658,822 659,071	658,796	658,726	658,656	658,609	657,734		
DIST.PARZIALI PROGETTO			10,000	1,688	1,291	3,500	3,500	2,379	1,312				
QUOTE PAVIMENTATO						659,006 659,206 659,196		659,126	659,056 658,846 659,046				
DIST.PARZIALI PAVIMENTATO						0,500	3,500	3,500	0,500				

SCAVI E BONIFICHE	
SCOTICO	23,556 m
BONIFICA	4,711 m ²
RILEVATI	
RILEVATO	39,966 m ²
TERRENO VEGETALE	16,471 m
SOVRASTRUTTURA STRADALE	
STRATO DI USURA	8,000 m
STRATO DI FONDAZIONE	2,074 m ²

SEZIONE N.: 25
 QT. PROGETTO: 659,126
 DIST.PROG.: 65,994
 DIST.PREC.: 2,599
 DIST.SUCC.: 5,108

SCALA 1:200

QT.RIF. 645,000

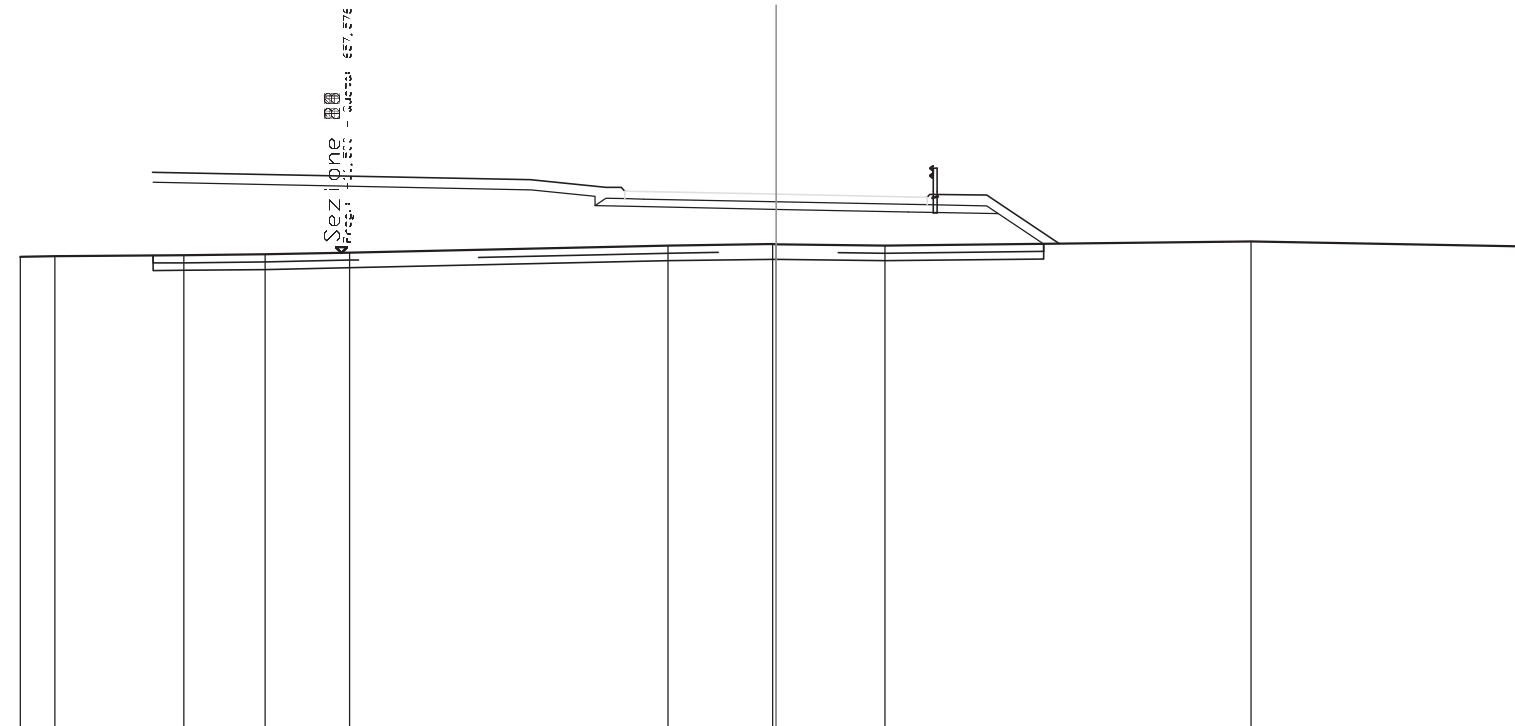

QUOTE TERRENO	657,466	657,487	657,512	657,533	657,581	657,765	657,804	657,803	657,763	657,872	657,743	
DIST.PARZIALI TERRENO	0,920	3,411	2,148	2,239	8,422	2,770	2,876	9,688	7,435			
QUOTE PROGETTO		659,440			659,240	659,822	659,071	659,796	659,726	659,656	659,609	657,810
DIST.PARZIALI PROGETTO			10,000		1,688	1,291	3,500	3,500	2,379	1,197		
QUOTE PAVIMENTATO					659,006	659,206	659,196	659,126	659,056	659,046		
DIST.PARZIALI PAVIMENTATO					0,500	3,500	3,500	0,500				

SCAVI E BONIFICHE	
SCOTICO	23,093 m
BONIFICA	4,619 m ²
RILEVATI	
RILEVATO	37,177 m ²
TERRENO VEGETALE	15,917 m
SOVRASTRUTTURA STRADALE	
STRATO DI USURA	8,000 m
STRATO DI FONDAZIONE	2,074 m ²

SEZIONE N.: 26
 QT. PROGETTO: 659,126
 DIST.PROG.: 71,102
 DIST.PREC.: 5,108
 DIST.SUCC.: 1,155

SCALA 1:200

QT.RIF. 645,000

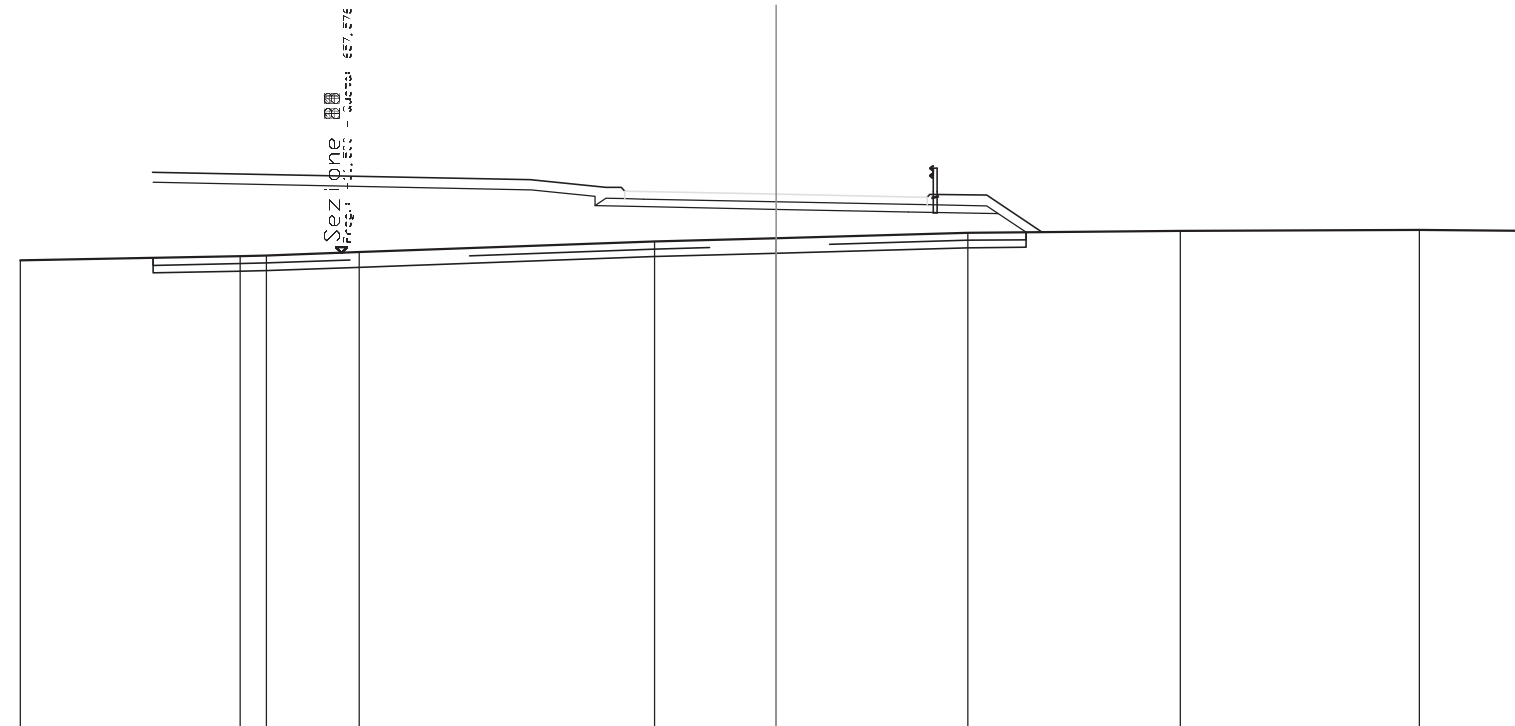

QUOTE TERRENO	657,373	657,489	657,506	657,593	657,873	657,963	658,106	658,154	658,178	658,153
DIST.PARZIALI TERRENO	5,824	0,694	2,455	7,815	3,212	5,076	5,622	6,320	2,983	
QUOTE PROGETTO	659,440	659,240	658,822	659,071	658,796	658,726	658,656	658,609	658,119	
DIST.PARZIALI PROGETTO	10,000	1,688	1,291	3,500	3,500	2,379	0,735			
QUOTE PAVIMENTATO		659,006	659,206	659,196	659,126	659,056	658,846	659,046		
DIST.PARZIALI PAVIMENTATO		0,500	3,500	3,500	0,500					

SCAVI E BONIFICHE	
SCOTICO	22,983 m
BONIFICA	4,597 m ²
RILEVATI	
RILEVATO	36,750 m ²
TERRENO VEGETALE	15,766 m
SOVRASTRUTTURA STRADALE	
STRATO DI USURA	8,000 m
STRATO DI FONDAZIONE	2,074 m ²

SEZIONE N.: 27
 QT. PROGETTO: 659,126
 DIST.PROG.: 72,257
 DIST.PREC.: 1,155

SCALA 1:200

QT.RIF. 645,000

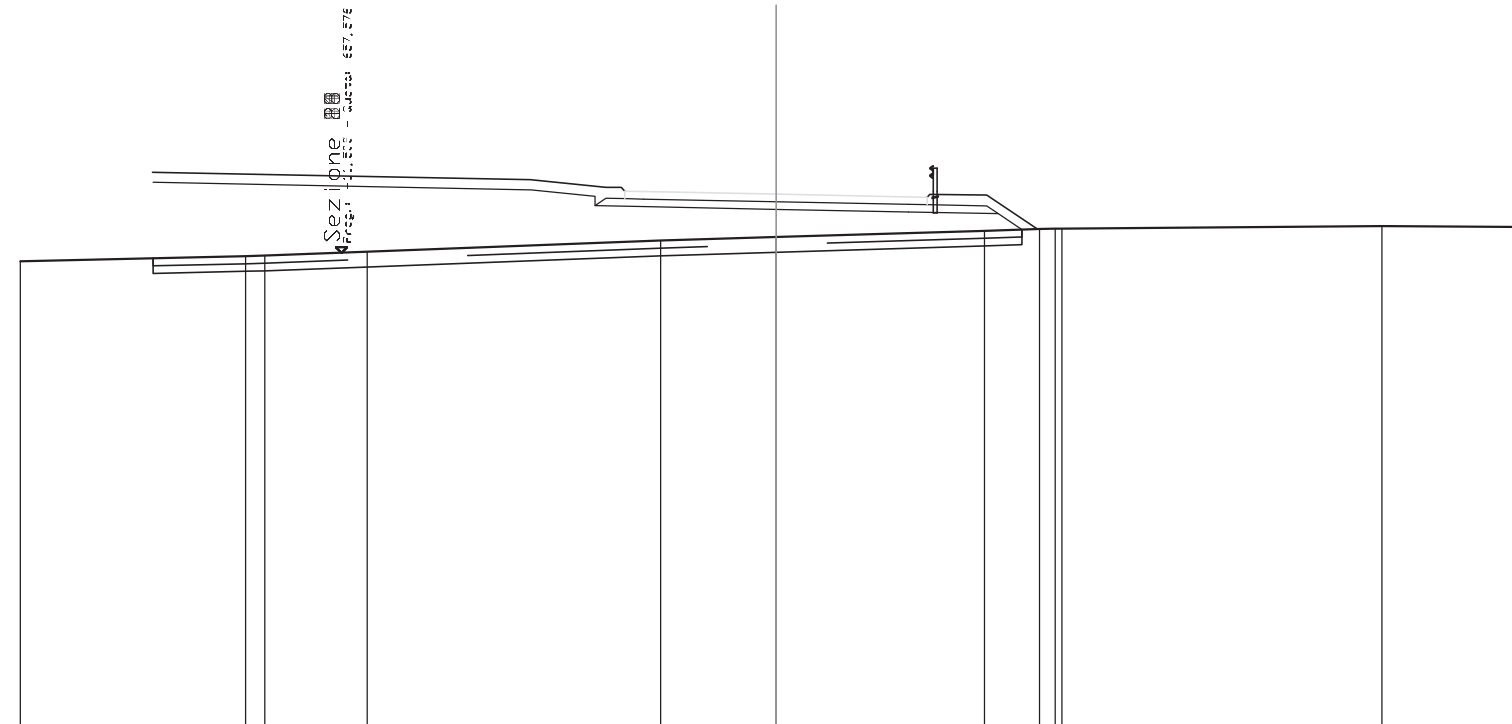

QUOTE TERRENO	657,353	657,486	657,500	657,602	657,898	657,991	658,159	658,208	658,211	658,215	658,278	658,259
DIST.PARZIALI TERRENO	5,966	0,506	2,706	7,763	3,059	5,514	1,456	0,418	8,472	3,967		
QUOTE PROGETTO	659,440	659,240	658,822	659,071	658,796	658,726	658,656	658,609	658,192			
DIST.PARZIALI PROGETTO	10,000	1,688	1,291	3,500	3,500	2,379	0,624					
QUOTE PAVIMENTATO		659,006	659,206	659,196	659,126	659,056	658,846	659,046				
DIST.PARZIALI PAVIMENTATO		0,500	3,500	3,500		0,500						