

**S.S.131 DI "CARLO FELICE"**  
Adeguamento e messa in sicurezza della S.S.131  
Risoluzione dei nodi critici 2° stralcio  
dal km 108+300 al km 158+000

**PROGETTO ESECUTIVO**

CA284

R.T.I. di PROGETTAZIONE:

Mandataria



**PRO  
ITER**  
Progetto  
Infrastrutture  
Territorio s.r.l.

Via G.B. Sammartini n°5  
20125 - Milano  
Tel. 02 6787911  
email: mail@proiter.it

Mandante



Via Artemide n°3  
92100 Agrigento  
Tel. 0922 421007  
email: deltaingegneria@pec.it

PROGETTISTI:

Ing. Riccardo Formichi - Pro Iter srl (Integratore prestazioni specialistiche)  
Ordine Ing. di Milano n. 18045

Ing. Nicola D'Alessandro - Delta Ingegneria srl  
Ordine Ing. di Agrigento n. A995

IL GEOLOGO

Dott. Geol. Massimo Mezzanatica - Pro Iter srl  
Albo Geol. Lombardia n. A762

COORDINATORE PER LA SICUREZZA IN FASE DI PROGETTAZIONE

Ing. Diego Ceccherelli  
Ordine Ing. di Milano n. 15813

VISTO: IL RESP. DEL PROCEDIMENTO

Dott. Ing. Salvatore Frasca

PROTOCOLLO

DATA



**PROGETTO STRADALE**

Risoluzione accessi C. S. dal Km 123+500 al Km 125+260

Sezioni trasversali

CODICE PROGETTO

PROGETTO LIV. PROG. N. PROG.

LOPLSQ E 1901

NOME FILE

S04PS00TRASZ01\_C

CODICE  
ELAB.

S04PS00TRASZ01

REVISIONE

SCALA

C

varie

REV.	DESCRIZIONE	DATA	REDATTO	VERIFICATO	APPROVATO
D					
C	REVISIONE PER ISTRUTTORIA, VERIFICA E CONTROLLI D.LGS. 35/11	Agosto 2020	Ing.D. D'ALESSANDRO	Ing. M. CARLINO	Ing.N. D'ALESSANDRO
B	Emissione	Marzo 2020	Ing.D. D'ALESSANDRO	Ing. M. CARLINO	Ing.N. D'ALESSANDRO
A	Emissione per controlli D.LGS. 35/2011	Novembre 2019	Ing.D. D'ALESSANDRO	Ing. M. CARLINO	Ing.N. D'ALESSANDRO

SCAVI E BONIFICHE	
STERRO	2,658 m <sup>3</sup>
RILEVATI	
TERRENO VEGETALE	3,244 m
SOVRASTRUTTURA STRADALE	
STRATI LEGATI	7,000 m
STRATO DI FONDAZIONE	1,425 m <sup>3</sup>

SEZIONE N. : 1  
 QT. PROGETTO: 308,925  
 DIST. PRG. : 0,000  
 DIST. SUCC. : 6,480

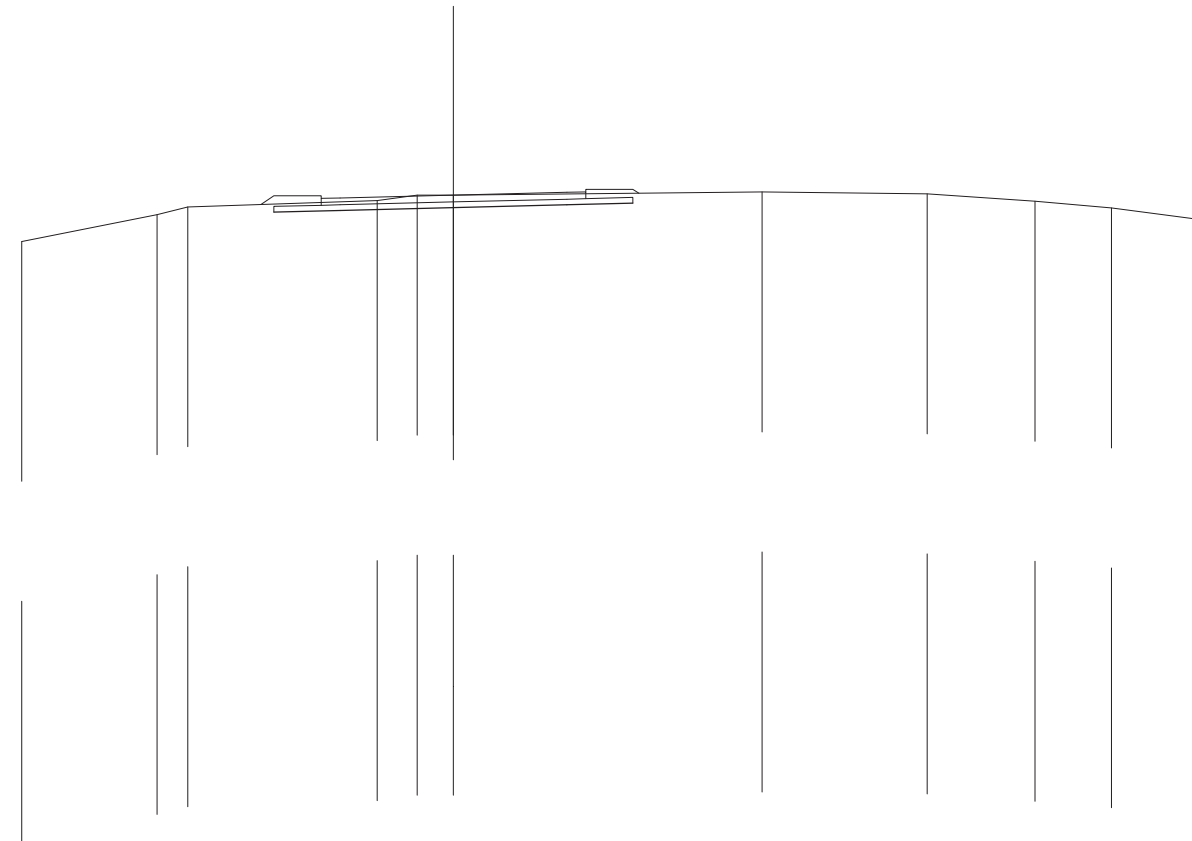

SCALA 1:200

QT. RIF. 290,000

QUOTE TERRENO		307,702		308,412	308,616		308,781	308,923	308,925		309,007		308,962	308,761	308,590	308,249
DIST. PARZIALI TERRENO			3,579	0,815		5,009	1,062	0,957		8,165		4,374	2,850	2,024	2,588	
QUOTE PROGETTO						308,476	308,520		308,595		308,670	308,713				
DIST. PARZIALI PROGETTO							1,750	3,000		3,000	1,750					
QUOTE PAVIMENTATO							308,657	308,837	308,850	308,925		309,000	308,832	309,012		
DIST. PARZIALI PAVIMENTATO							0,500	3,000		3,000	0,500					



SCAVI E BONIFICHE	
SCOTICO	12,235 m
BONIFICA	3,670 m
RILEVATI	
RILEVATO	16,119 m
TERRENO VEGETALE	6,769 m
SOVRASTRUTTURA STRADALE	
STRATI LEGATI	7,000 m
STRATO DI FONDAZIONE	1,459 m

SEZIONE N. : 3  
 QT. PROGETTO: 308,802  
 DIST. PROG. : 31,480  
 DIST. PREC. : 25,000  
 DIST. SUCC. : 25,000

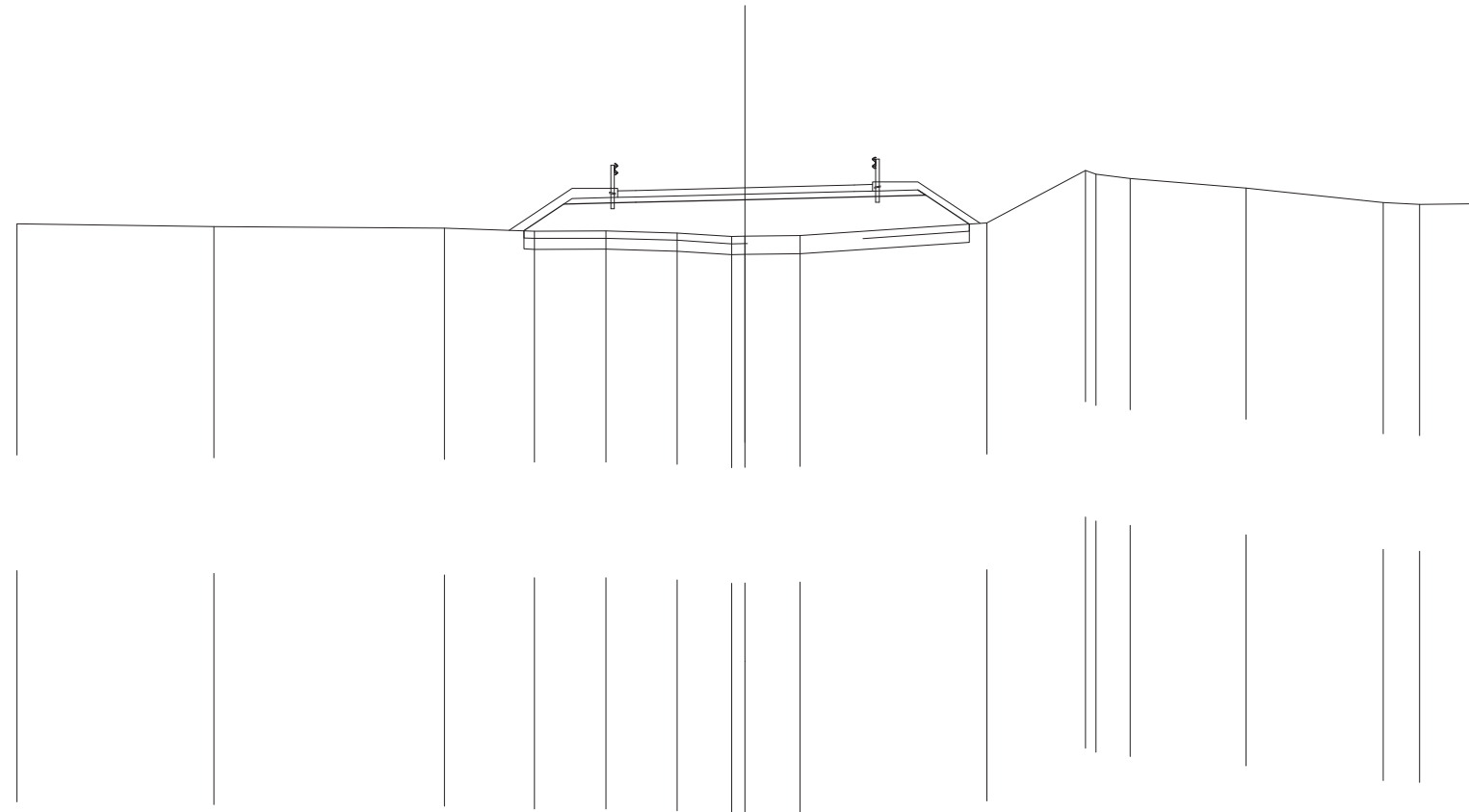

SCALA 1:200

QT. RIF. 290,000

QUOTE TERRENO	307,804	307,734	307,688	307,609	307,612	307,556	307,460 307,466	307,490	307,834	309,276 309,169	309,055	308,793	308,391	308,340	308,356
DIST. PARZIALI TERRENO	5,407	6,337	2,467	1,968	1,960	1,497	1,515	5,129	2,706	0,945	3,178	3,773	1,001	1,464	
QUOTE PROGETTO				307,618	308,347	308,397	308,472	308,547	308,740 308,596	307,801					
DIST. PARZIALI PROGETTO				1,093	1,984	3,000	3,000	1,750	1,192						
QUOTE PAVIMENTATO				308,534 308,714 308,727			308,802	308,877 308,709 308,889							
DIST. PARZIALI PAVIMENTATO				0,500	3,000	3,000	0,500								



SCAVI E BONIFICHE	
SCOTICO	11,312 m
BONIFICA	4,525 m
RILEVATI	
RILEVATO	13,720 m
TERRENO VEGETALE	5,693 m
SOVRASTRUTTURA STRADALE	
STRATI LEGATI	7,000 m
STRATO DI FONDAZIONE	1,459 m

SEZIONE N. : 5  
 QT. PROGETTO: 308,909  
 DIST. PRG. : 81,480  
 DIST. PREC. : 25,000  
 DIST. SUCC. : 25,000

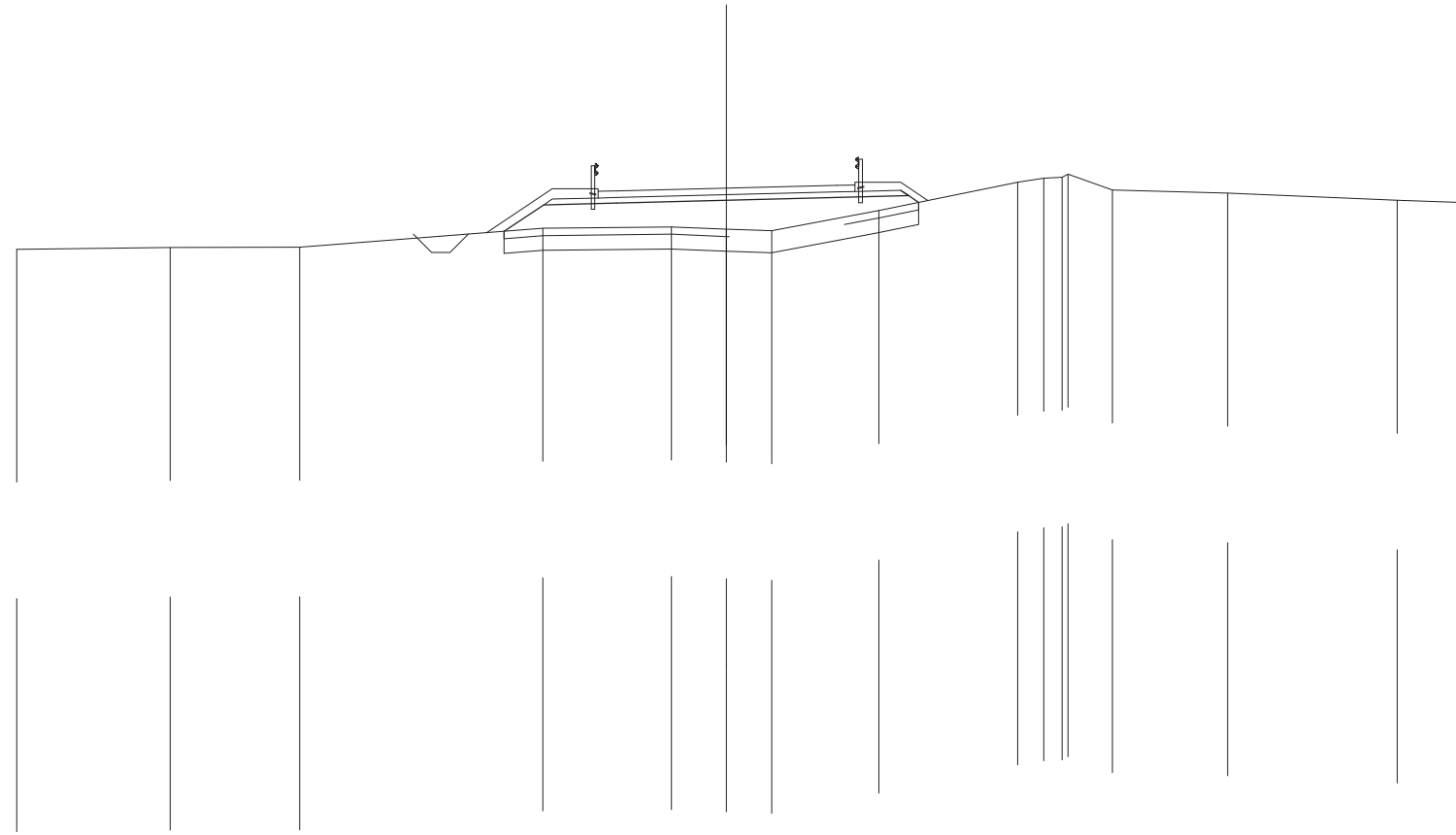

SCALA 1:200

QT. RIF. 290,000

QUOTE TERRENO	307,245	307,290	307,298	307,813	307,852	307,792	307,747	308,298	309,070	309,179	309,203	309,288	308,856	308,773	308,575	308,517
DIST. PARZIALI TERRENO	4,187	3,523	6,632	3,510	1,499	1,234	2,922	3,787	0,706	0,502	1,208	3,144	4,622	1,715		
QUOTE PROGETTO				307,730	308,454	308,504	308,579	308,654	308,848	308,703	308,519					
DIST. PARZIALI PROGETTO				1,086	1,984	3,000	3,000	1,750								
QUOTE PAVIMENTATO						308,641	308,909	308,984	308,816	308,956						
DIST. PARZIALI PAVIMENTATO						0,500	3,000	3,000	0,500							



SCAVI E BONIFICHE	
SCOTICO	10,855 m
BONIFICA	4,342 m
RILEVATI	
RILEVATO	12,697 m
TERRENO VEGETALE	5,068 m
SOVRASTRUTTURA STRADALE	
STRATI LEGATI	7,000 m
STRATO DI FONDAZIONE	1,459 m

SEZIONE N. : 7  
 QT. PROGETTO: 309,016  
 DIST. PROG. : 131,479  
 DIST. PREC. : 25,000  
 DIST. SUCC. : 25,000

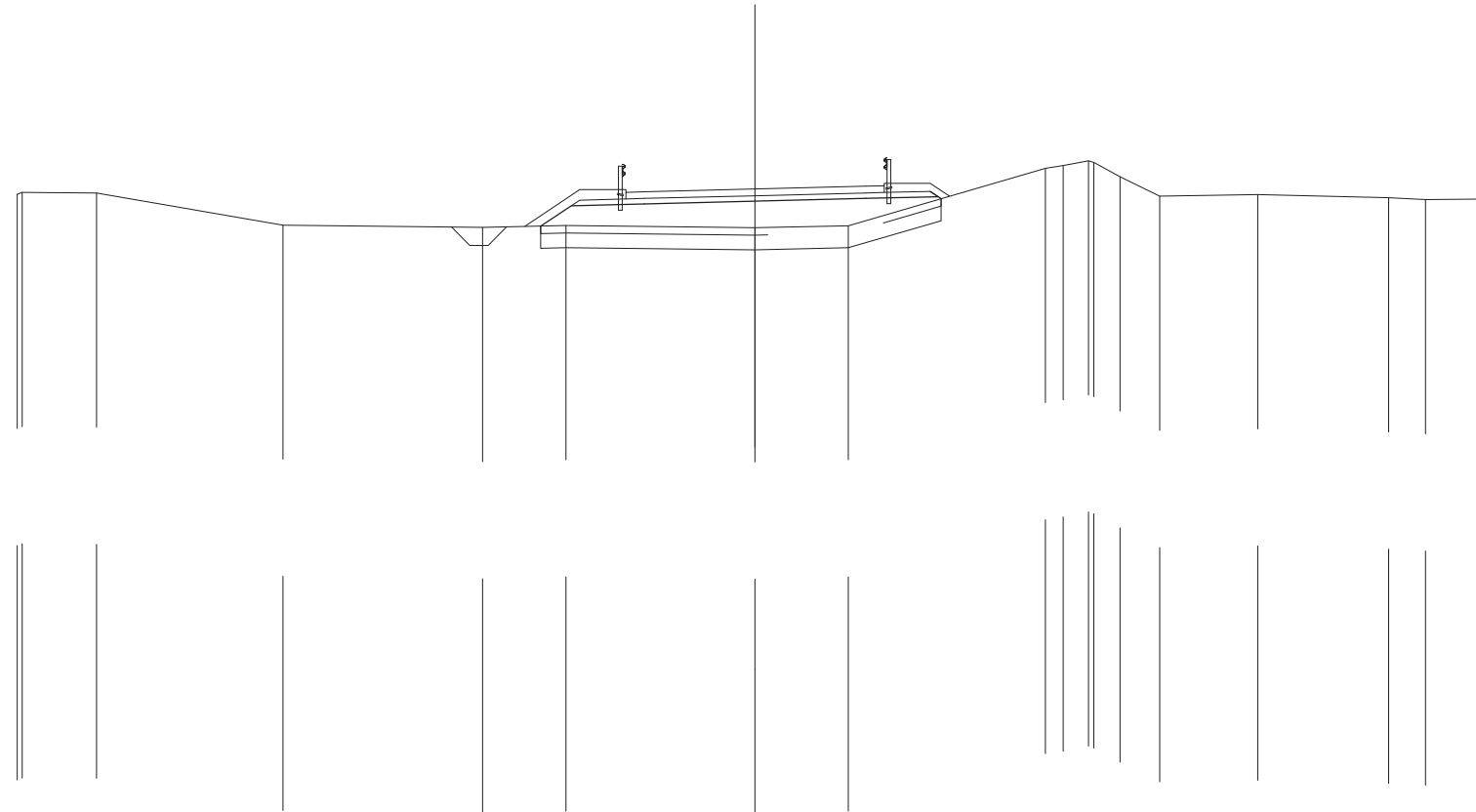

SCALA 1:200

QT. RIF. 290,000

QUOTE TERRENO	308,871 308,922	308,911	308,041	307,976	308,027	307,968	308,024	309,580 309,651	309,784 309,740	309,352	308,822	308,863	308,780 308,730	308,747
DIST. PARZIALI TERRENO	2,014	5,059	5,411	2,256	5,128	2,532	5,338	0,487 0,682	0,707	1,079	2,656	3,549	1,001	1,821
QUOTE PROGETTO					308,012 308,562	308,611	308,686	308,761	308,955 308,810 308,757					
DIST. PARZIALI PROGETTO					0,824	1,984	3,000	3,000	1,750					
QUOTE PAVIMENTATO						308,749 308,929 308,941	309,016	309,091 308,924 309,104						
DIST. PARZIALI PAVIMENTATO						0,500	3,000	3,000	0,500					













SCAVI E BONIFICHE	
SCOTICO	11,372 m
BONIFICA	4,549 m
RILEVATI	
RILEVATO	12,702 m
TERRENO VEGETALE	5,673 m
SOVRASTRUTTURA STRADALE	
STRATI LEGATI	7,000 m
STRATO DI FONDAZIONE	1,459 m

SEZIONE N. : 13  
 QT. PROGETTO: 309,338  
 DIST. PRG. : 281,479  
 DIST. PREC. : 25,000  
 DIST. SUCC. : 25,000

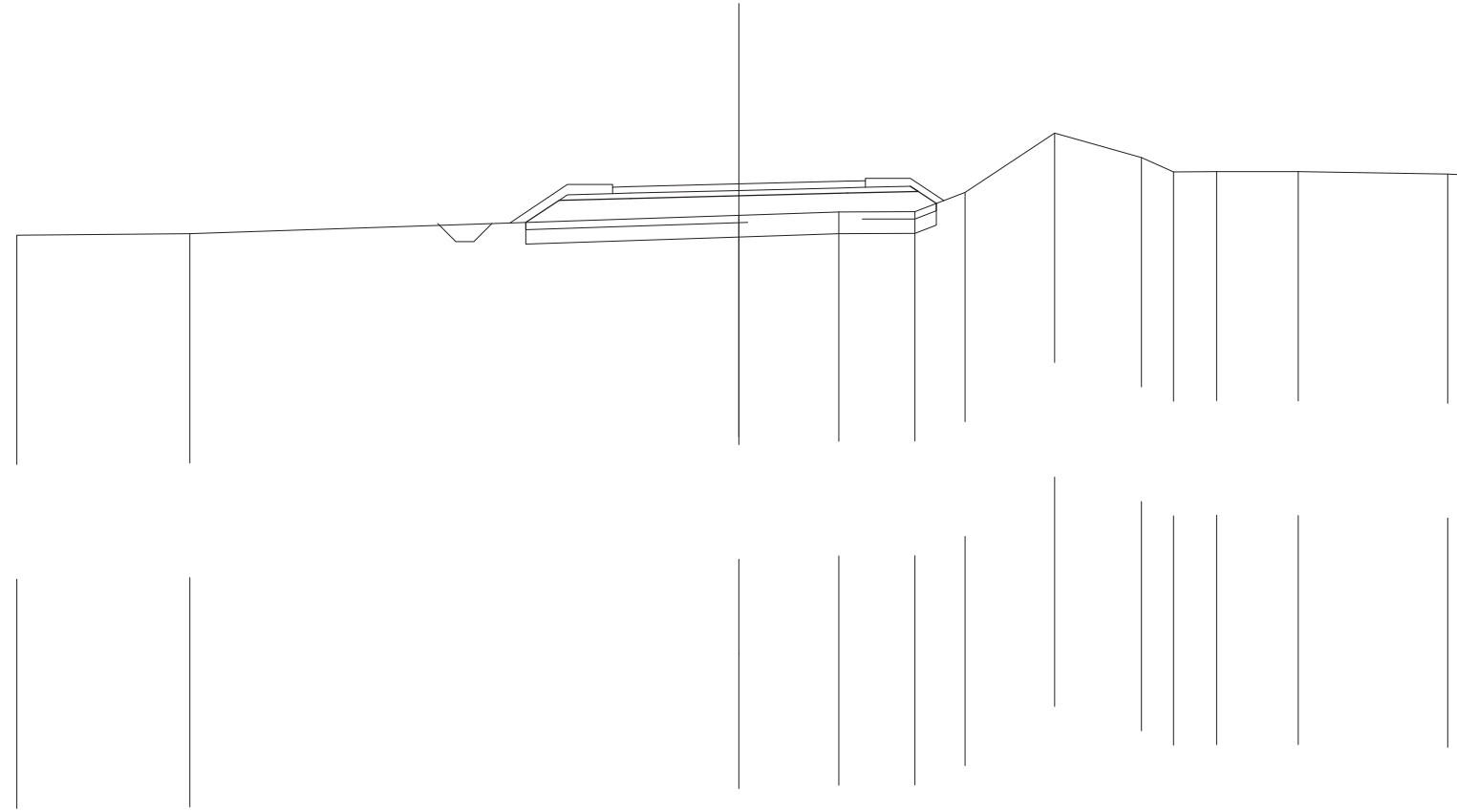

SCALA 1:200

QT. RIF. 290,000

QUOTE TERRENO		307,916	307,959		308,468	308,562	308,567	309,105	310,744	310,071	309,667	309,683	309,682	309,611	309,593
DIST. PARZIALI TERRENO		4,789		15,211		2,768	2,105	1,389	2,479	2,407	0,888	1,199	2,261	4,140	
QUOTE PROGETTO					308,270	308,884	308,933	309,008	309,083	309,277	309,132	308,796			
DIST. PARZIALI PROGETTO					0,920	1,984	3,000	3,000	1,750	0,502					
QUOTE PAVIMENTATO							309,071	309,338	309,413	309,426	309,246				
DIST. PARZIALI PAVIMENTATO							0,500	3,000	3,000	0,500					



SCAVI E BONIFICHE	
SCOTICO	11,971 m
BONIFICA	3,591 m
RILEVATI	
RILEVATO	13,828 m
TERRENO VEGETALE	6,315 m
SOVRASTRUTTURA STRADALE	
STRATI LEGATI	7,000 m
STRATO DI FONDAZIONE	1,459 m

SEZIONE N. : 15  
 QT. PROGETTO: 309,423  
 DIST. PRG. : 320,898  
 DIST. PREC. : 14,419  
 DIST. SUCC. : 10,581

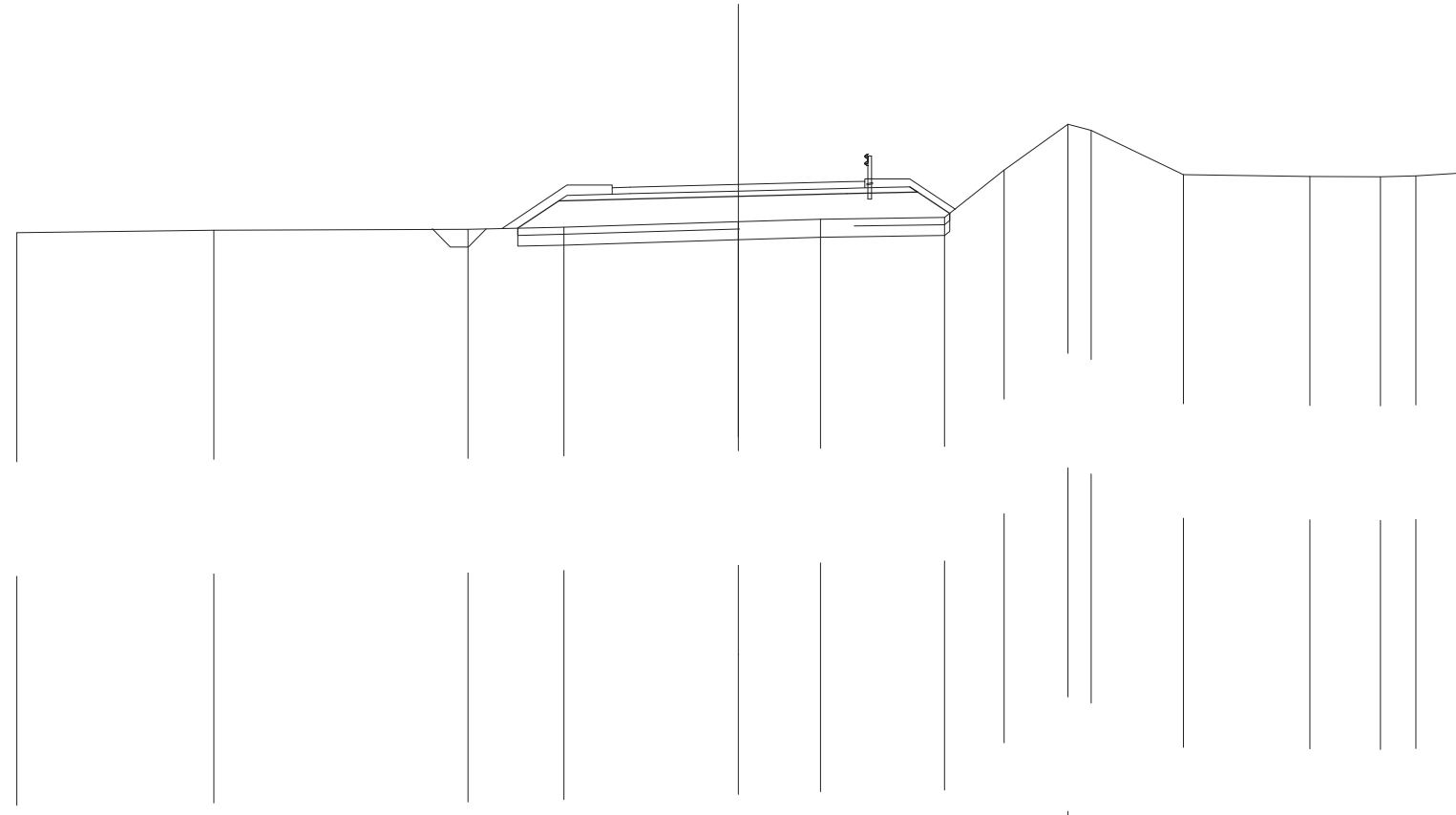

SCALA 1:200

QT. RIF. 290,000

QUOTE TERRENO	308,084	308,154	308,182	308,243	308,390	308,463	308,511	309,823	311,090	310,923	309,698	309,649	309,637	309,664	309,742
DIST. PARZIALI TERRENO	5,456	7,048	2,655	4,841	2,277	3,438	1,649	1,772	0,641	2,556	3,509	1,955	0,988	1,217	
QUOTE PROGETTO			308,214	308,968	309,018	309,093	309,168	309,262	309,217	308,624					
DIST. PARZIALI PROGETTO			1,131	1,984	3,000	3,000	1,750	0,889							
QUOTE PAVIMENTATO				309,335	309,155	309,348	309,423	309,498	309,530	309,510					
DIST. PARZIALI PAVIMENTATO				0,500	3,000	3,000	0,500								





SCAVI E BONIFICHE	
SCOTICO	11,271 m
BONIFICA	4,508 m
RILEVATI	
RILEVATO	12,514 m
TERRENO VEGETALE	5,623 m
SOVRASTRUTTURA STRADALE	
STRATI LEGATI	7,000 m
STRATO DI FONDAZIONE	1,459 m

SEZIONE N. : 17  
 QT. PROGETTO: 309,492  
 DIST. PRG. : 353,105  
 DIST. PREC. : 21,627  
 DIST. SUCC. : 30,697

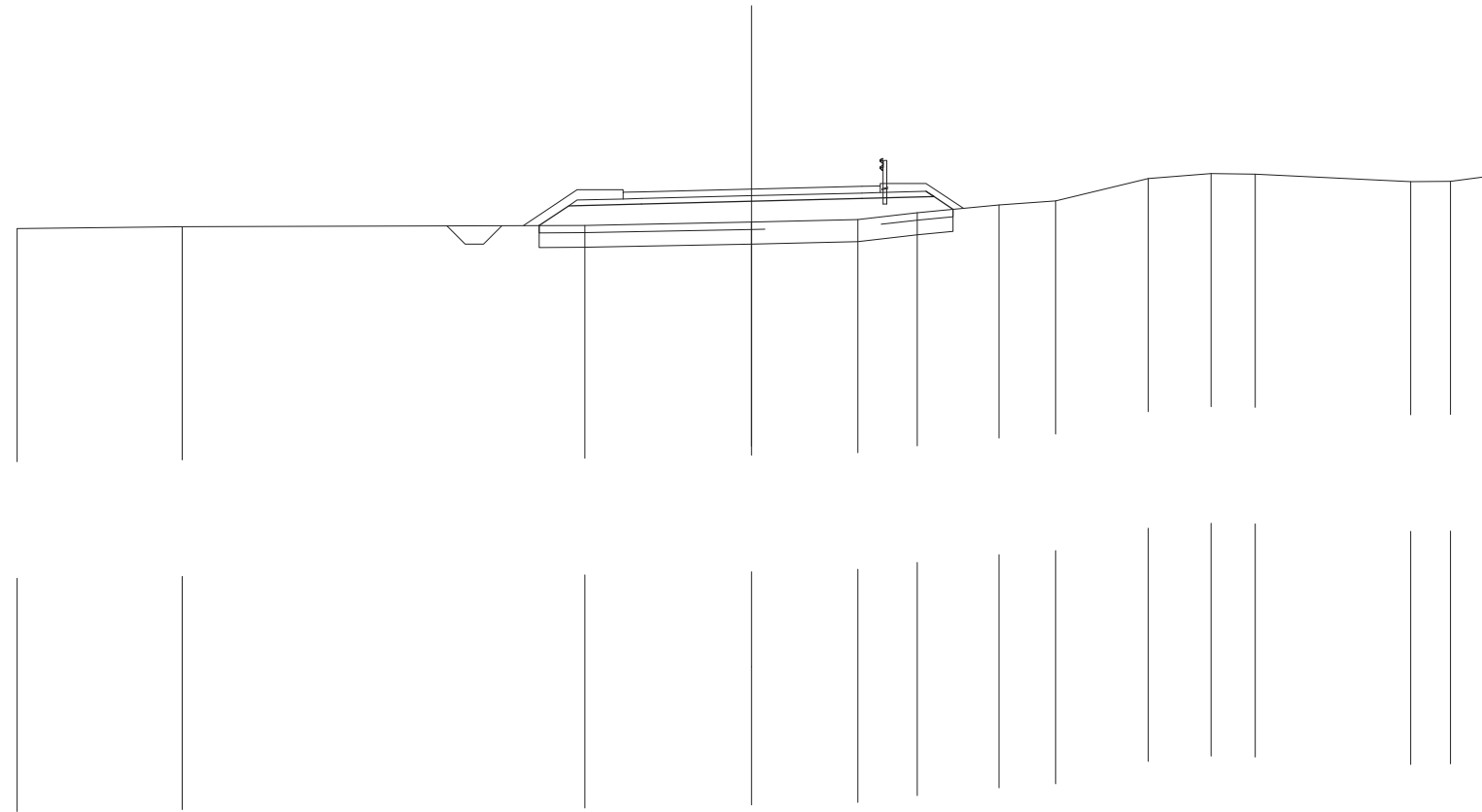

SCALA 1:200

QT. RIF. 290,000

QUOTE TERRENO	308,414	308,466	308,507	308,596	308,659	308,849	309,061	309,168	309,779	309,919	309,898	309,696	309,707	309,833
DIST. PARZIALI TERRENO	4,492	10,970	4,538	2,895	1,614	2,226	1,543	2,525	1,714	1,202	4,230	1,082	0,969	
QUOTE PROGETTO			308,502 309,038	309,087	309,162	309,237	309,431 309,387 308,942							
DIST. PARZIALI PROGETTO			0,803 1,984	3,000	3,000	1,750	0,517							
QUOTE PAVIMENTATO				309,225 309,405 309,417	309,492	309,567 309,400 309,580								
DIST. PARZIALI PAVIMENTATO				0,500 3,000	3,000	0,500								



















SCAVI E BONIFICHE	
STERRO	0,835 m <sup>3</sup>
SCOTICO	0,303 m
BONIFICA	2,985 m <sup>3</sup>
RILEVATI	
RILEVATO	4,124 m <sup>3</sup>
TERRENO VEGETALE	3,499 m
SOVRASTRUTTURA STRADALE	
STRATI LEGATI	7,000 m
STRATO DI FONDAZIONE	1,459 m <sup>3</sup>

SEZIONE N. : 26  
 QT. PROGETTO: 314,300  
 DIST. PRG. : 562,072  
 DIST. PREC. : 18,209  
 DIST. SUCC. : 18,595

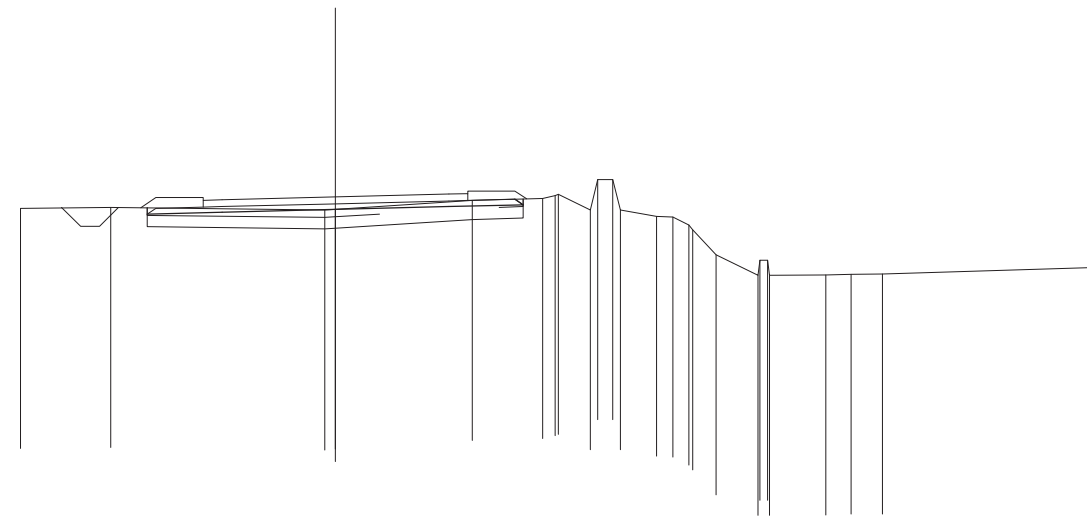

SCALA 1:200

QT. RIF. 300,000

QUOTE TERRENO		314,000	314,025		313,958 313,978	314,205	314,261 314,334 314,373 313,959 314,759 314,759 313,959 313,790 313,771 313,560 313,731 312,770	312,227 312,227 312,227 312,234 312,257 312,260		312,432
DIST. PARZIALI TERRENO		2,386	5,664		3,621	1,866	0,846 0,400 0,952 0,434 0,425 0,621 1,109	1,495 0,669 0,832	5,524	
QUOTE PROGETTO			313,846	313,895	313,970	314,045	314,239 314,694			
DIST. PARZIALI PROGETTO			1,984	3,000	3,000	1,750				
QUOTE PAVIMENTATO			314,213 314,225		314,300	314,375 314,388				
DIST. PARZIALI PAVIMENTATO			0,500 3,000		3,000	0,500				









SCAVI E BONIFICHE	
SCOTICO	10,698 m
BONIFICA	3,209 m
RILEVATI	
RILEVATO	8,856 m
TERRENO VEGETALE	4,947 m
SOVRASTRUTTURA STRADALE	
STRATI LEGATI	7,000 m
STRATO DI FONDAZIONE	1,459 m

SEZIONE N.: 31  
 QT. PROGETTO: 315,511  
 DIST. PRG.: 668,125  
 DIST. PREC.: 24,448  
 DIST. SUCC.: 24,454

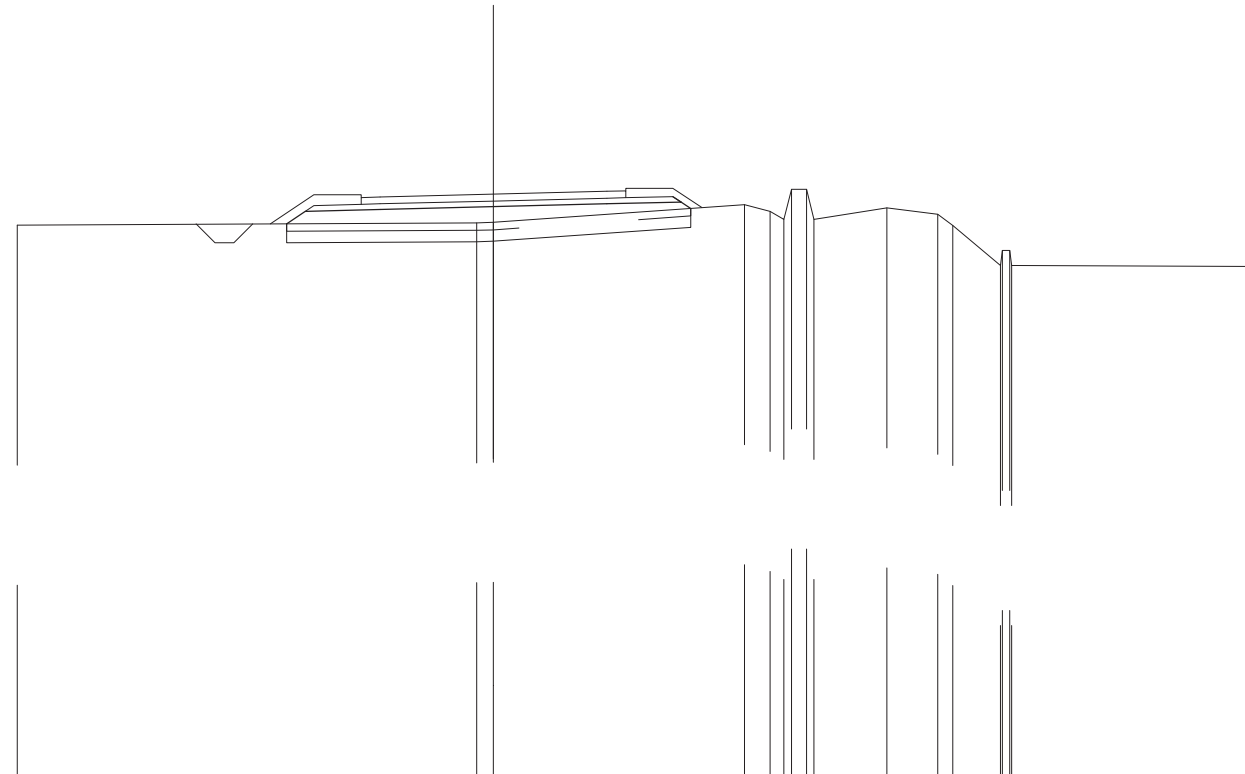

SCALA 1:200

QT. RIF. 300,000

QUOTE TERRENO		314,691		314,754 314,764		315,236 315,055 314,844 315,644 315,644 314,844	315,152	314,980 314,680	313,621 314,021 313,621	313,602
DIST. PARZIALI TERRENO			12,158	0,442	6,644	0,679 0,400 1,930	1,347	0,396 1,260	6,281	
QUOTE PROGETTO				314,728 315,056		315,106	315,181	315,256	315,450 315,305 315,135	
DIST. PARZIALI PROGETTO				0,492	1,984	3,000	3,000	1,750		
QUOTE PAVIMENTATO				315,243 315,423 315,436		315,511	315,586 315,598 315,418			
DIST. PARZIALI PAVIMENTATO				0,500	3,000	3,000	0,500			

















SCAVI E BONIFICHE	
STERRO	0,048m <sup>3</sup>
SCOTICO	9,933m
BONIFICA	3,078m <sup>3</sup>
RILEVATI	
RILEVATO	8,041m <sup>3</sup>
TERRENO VEGETALE	4,105m
SOVRASTRUTTURA STRADALE	
STRATI LEGATI	7,000m
STRATO DI FONDAZIONE	1,459m <sup>3</sup>

SEZIONE N. : 39  
 QT. PROGETTO: 318,185  
 DIST. PRG. : 840,186  
 DIST. PREC. : 25,000  
 DIST. SUCC. : 25,000

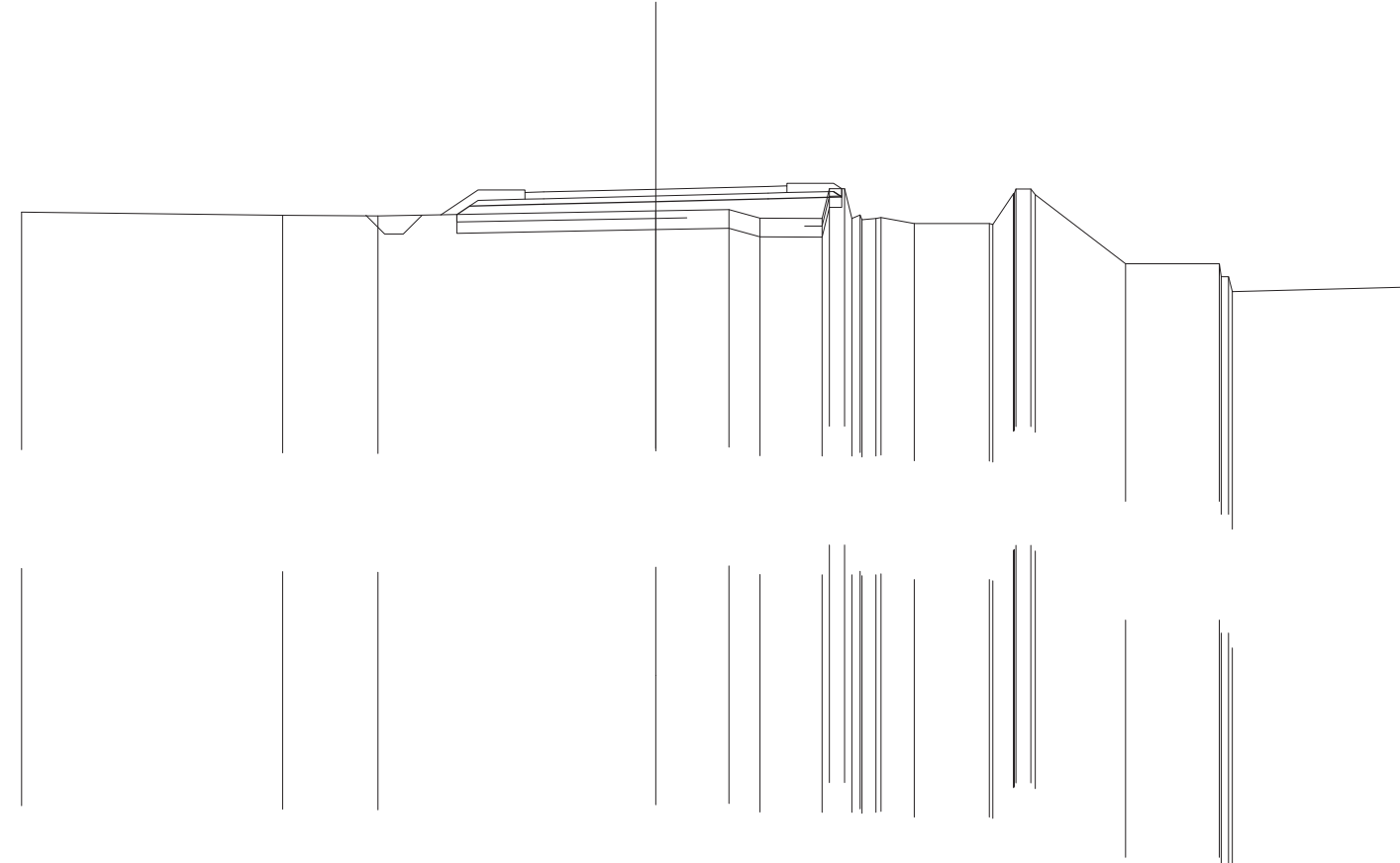

SCALA 1:200

QT. RIF. 300,000

QUOTE TERRENO	317,573	317,484	317,468	317,602	317,637	317,412	317,399	317,262	316,193	315,193	315,564
DIST. PARZIALI TERRENO	6,979	2,546	7,432	1,953	0,828	1,659	0,400	0,553	2,418	2,501	4,591
QUOTE PROGETTO			317,506	317,855	317,930	319,123	317,979	318,092	318,036		
DIST. PARZIALI PROGETTO			1,984	3,000	3,000	1,750					
QUOTE PAVIMENTATO			317,917	318,185	318,260	318,272					
DIST. PARZIALI PAVIMENTATO			0,500	3,000	3,000	0,500					







SCAVI E BONIFICHE	
STERRO	1,101 m <sup>3</sup>
SCOTICO	0,672 m <sup>3</sup>
BONIFICA	2,833 m <sup>3</sup>
RILEVATI	
RILEVATO	3,770 m <sup>3</sup>
TERRENO VEGETALE	4,041 m <sup>3</sup>
SOVRASTRUTTURA STRADALE	
STRATI LEGATI	6,500 m <sup>3</sup>
STRATO DI FONDAZIONE	1,366 m <sup>3</sup>

SEZIONE N. : 42  
 QT. PROGETTO: 317,713  
 DIST. PRG. : 915,186  
 DIST. PREC. : 25,000  
 DIST. SUCC. : 25,000

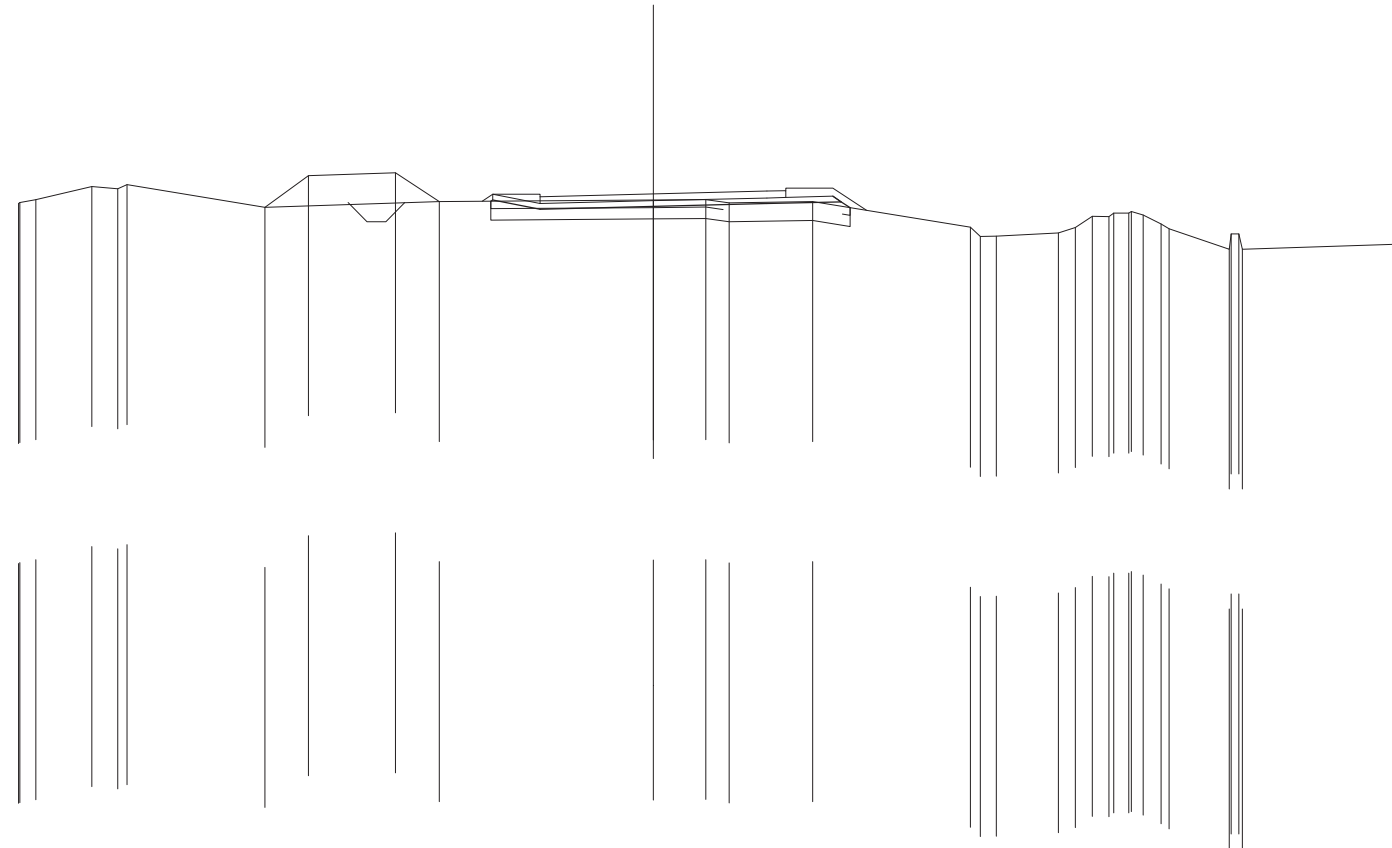

SCALA 1:200

QT. RIF. 300,000

QUOTE TERRENO	317,464 317,483 317,564	317,908 317,852 317,962	317,359	318,198	318,275	317,513	317,554	317,565 317,477	317,511	316,822 316,836 316,596	316,684 316,823 317,121 317,114 317,503 317,248 317,155 316,922 316,792	316,254 316,254 316,254	316,394	
DIST. PARZIALI TERRENO	0,424 1,483	0,687	3,647	1,153	2,307	1,153	5,671	1,387 0,616	2,213	4,175	0,417 1,644	0,447 0,456 0,436 0,400 0,479	1,594	4,409
QUOTE PROGETTO	317,523 317,558	317,308					317,383		317,458	317,652 317,507 317,351				
DIST. PARZIALI PROGETTO	1,250	3,000					3,000		1,750					
QUOTE PAVIMENTATO	317,638 317,458						317,713		317,788 317,621 317,801					
DIST. PARZIALI PAVIMENTATO	3,000						3,000		0,500					



SCAVI E BONIFICHE	
SCOTICO	10,717m
BONIFICA	3,215m
RILEVATI	
RILEVATO	10,091m
TERRENO VEGETALE	4,909m
SOVRASTRUTTURA STRADALE	
STRATI LEGATI	7,000m
STRATO DI FONDAZIONE	1,459m

SEZIONE N. : 44  
 QT. PROGETTO: 317,289  
 DIST. PRG. : 965,185  
 DIST. PREC. : 25,000  
 DIST. SUCC. : 25,000

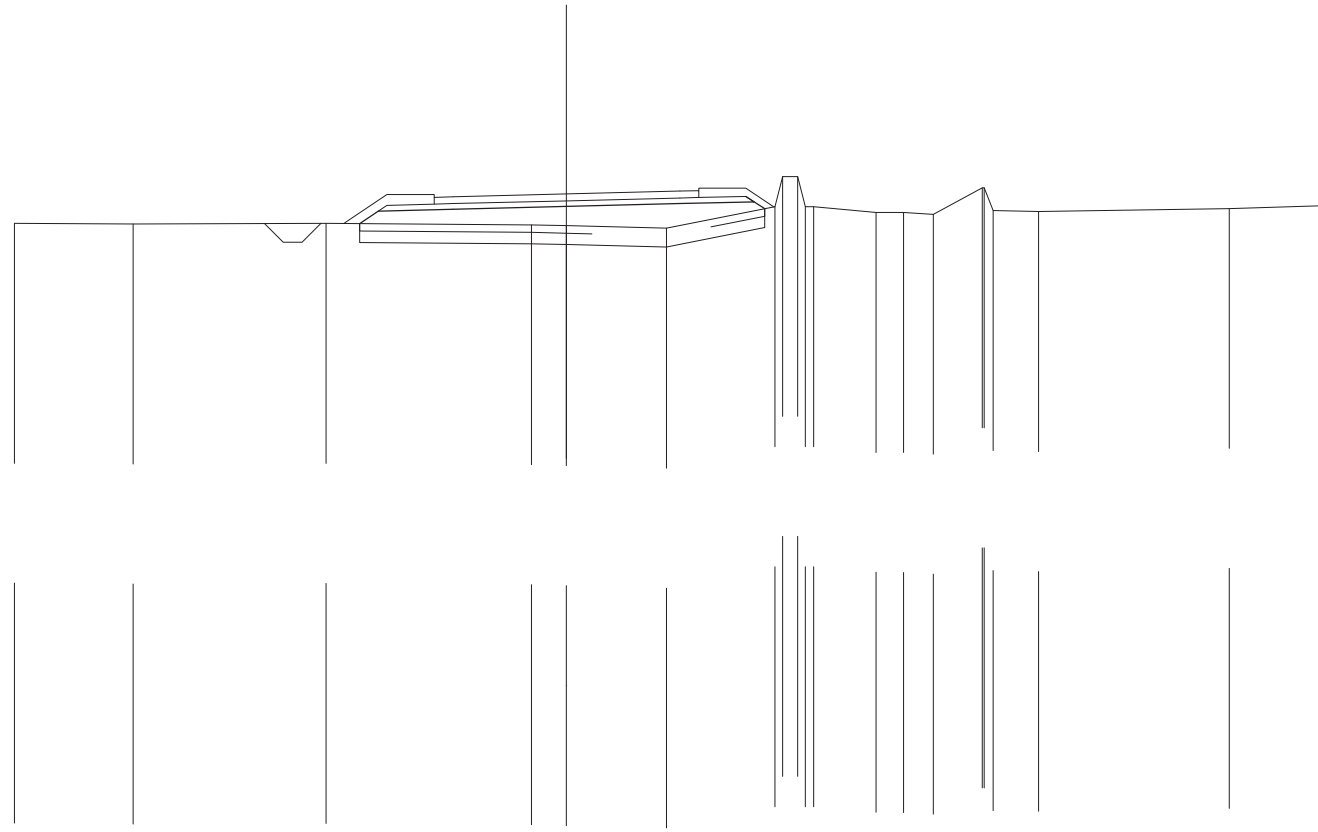

SCALA 1:200

QT. RIF. 300,000

QUOTE TERRENO	316,516	316,493	316,514	316,474	316,452	316,388	316,952	316,803	316,802	316,754	317,452	316,906	316,979
DIST. PARZIALI TERRENO	3,140	5,103	5,439	0,925	2,650	2,869	0,400	1,650	0,730	0,793	1,295	5,051	2,453
QUOTE PROGETTO			316,508 316,834	316,884	316,959	317,034	317,288 317,688 316,898						
DIST. PARZIALI PROGETTO			0,490	1,984	3,000	3,000	1,750						
QUOTE PAVIMENTATO			317,021 317,201 317,214	317,289	317,364 317,196 317,376								
DIST. PARZIALI PAVIMENTATO			0,500	3,000	3,000	0,500							

















SCAVI E BONIFICHE	
STERRO	0,000 m <sup>3</sup>
SCOTICO	10,004 m
BONIFICA	3,019 m <sup>3</sup>
RILEVATI	
RILEVATO	6,302 m <sup>3</sup>
TERRENO VEGETALE	4,082 m
SOVRASTRUTTURA STRADALE	
STRATI LEGATI	7,000 m
STRATO DI FONDAZIONE	1,459 m <sup>3</sup>

SEZIONE N. : 52  
 QT. PROGETTO: 316,420  
 DIST. PRG. : 1114,617  
 DIST. PREC. : 21,388  
 DIST. SUCC. : 25,000

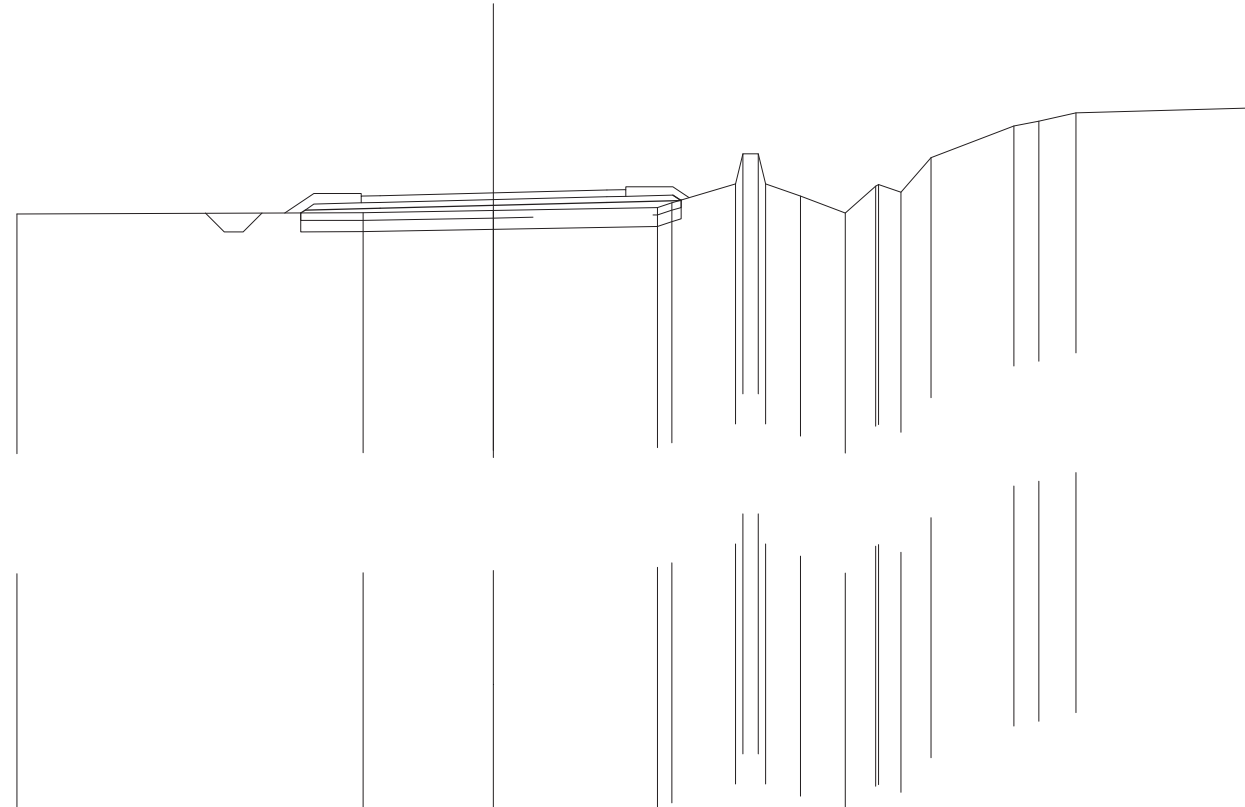

SCALA 1:200

QT. RIF. 300,000

QUOTE TERRENO		315,864		315,895		315,954		316,023	316,158	316,653	316,884		318,187		318,662
DIST. PARZIALI TERRENO			9,162		3,453		4,344		1,666	0,401	0,586	0,799	2,192	0,661	4,582
QUOTE PROGETTO				315,882	316,015	316,090	316,165	316,359							
DIST. PARZIALI PROGETTO				1,984	3,000	3,000	1,750								
QUOTE PAVIMENTATO				316,153	316,345	316,420	316,495	316,508							
DIST. PARZIALI PAVIMENTATO				0,500	3,000	3,000	0,500								



SCAVI E BONIFICHE	
STERRO	0,594 m <sup>3</sup>
SCOTICO	8,760 m
BONIFICA	2,853 m <sup>3</sup>
RILEVATI	
RILEVATO	7,354 m <sup>3</sup>
TERRENO VEGETALE	3,529 m
SOVRASTRUTTURA STRADALE	
STRATI LEGATI	7,000 m
STRATO DI FONDAZIONE	1,459 m <sup>3</sup>

SEZIONE N. : 54  
 QT. PROGETTO: 316,399  
 DIST. PROG. : 1164,617  
 DIST. PREC. : 25,000  
 DIST. SUCC. : 25,000

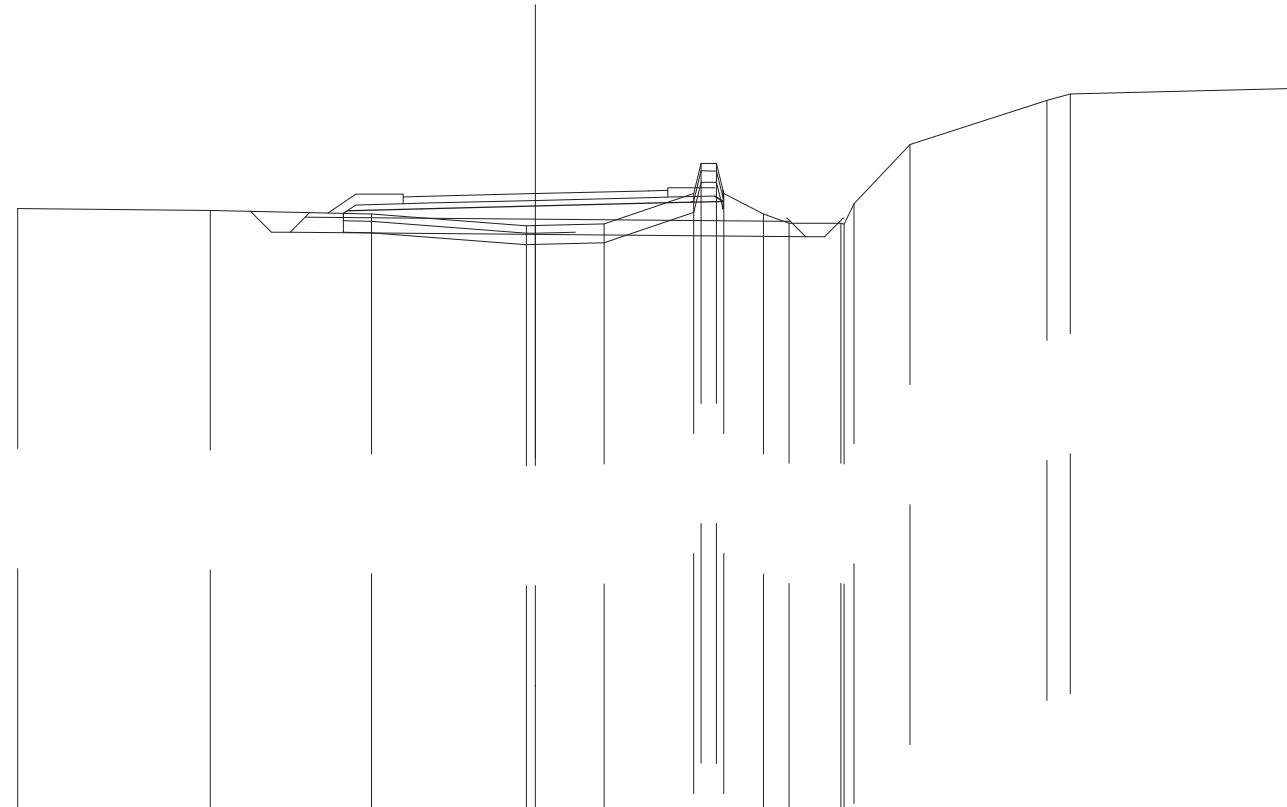

SCALA 1:200

QT. RIF. 300,000

QUOTE TERRENO	316,006	315,957	315,863	315,550 315,555	315,599	315,401 317,201 317,199 316,398	315,859 315,613	315,612 315,593 316,134	317,699	318,867 319,040	319,178
DIST. PARZIALI TERRENO	5,101	4,263	4,102	1,820	2,366	0,402 1,050 0,674	1,374	1,488	3,621	0,615	5,847
QUOTE PROGETTO			315,880 315,945	315,994	316,069	316,144	316,338 316,194				
DIST. PARZIALI PROGETTO			1,984	3,000	3,000	1,750					
QUOTE PAVIMENTATO			316,312 316,132 316,324	316,399	316,474 316,307 316,487						
DIST. PARZIALI PAVIMENTATO			0,500	3,000	3,000	0,500					

SCAVI E BONIFICHE	
STERRO	2,078 m <sup>3</sup>
SCOTICO	1,434 m
BONIFICA	2,443 m <sup>3</sup>
RILEVATI	
RILEVATO	3,282 m <sup>3</sup>
TERRENO VEGETALE	2,499 m
SOVRASTRUTTURA STRADALE	
STRATI LEGATI	7,000 m
STRATO DI FONDAZIONE	1,255 m <sup>3</sup>

SEZIONE N. : 55  
 QT. PROGETTO: 316,832  
 DIST. PRG. : 1189,617  
 DIST. PREC. : 25,000  
 DIST. SUCC. : 25,000

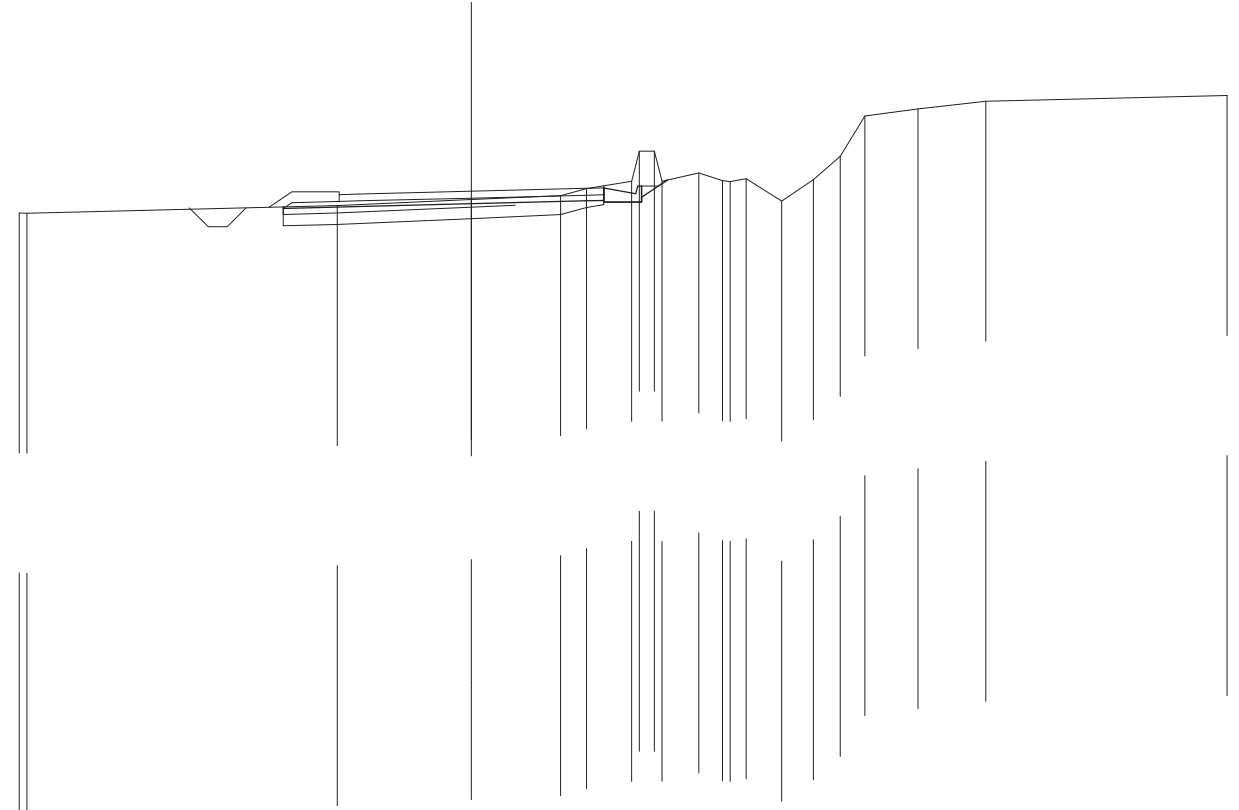

SCALA 1:200

QT. RIF. 300,000

QUOTE TERRENO	316,256 316,256	316,455	316,610	316,715 316,904	317,094 317,894 317,894 317,094	317,315 317,111 317,022 317,164	316,571 317,136 317,753 318,828	319,015 319,215	319,368	
DIST. PARZIALI TERRENO	8,219	3,549	2,362	0,688 1,191	0,400 0,975	0,629 0,419 0,937	0,845 0,708 0,654	1,401	1,802	6,382
QUOTE PROGETTO	316,378	316,427	316,502	316,577 316,550 316,520	316,550 316,570	316,550 316,670 317,127				
DIST. PARZIALI PROGETTO	1,984	3,000	3,000	0,300 0,850	0,686					
QUOTE PAVIMENTATO	316,565 316,745 316,757	316,832	316,907 316,740 316,920							
DIST. PARZIALI PAVIMENTATO	0,500	3,000	3,000	0,500						









SCAVI E BONIFICHE	
STERRO	3,416 m <sup>3</sup>
RILEVATI	
TERRENO VEGETALE	2,061 m
SOVRASTRUTTURA STRADALE	
STRATI LEGATI	7,000 m
STRATO DI FONDAZIONE	1,050 m <sup>3</sup>

SEZIONE N. : 59  
 QT. PROGETTO: 318,750  
 DIST. PROG. : 1277,591  
 DIST. PREC. : 12,975  
 DIST. SUCC. : 12,032

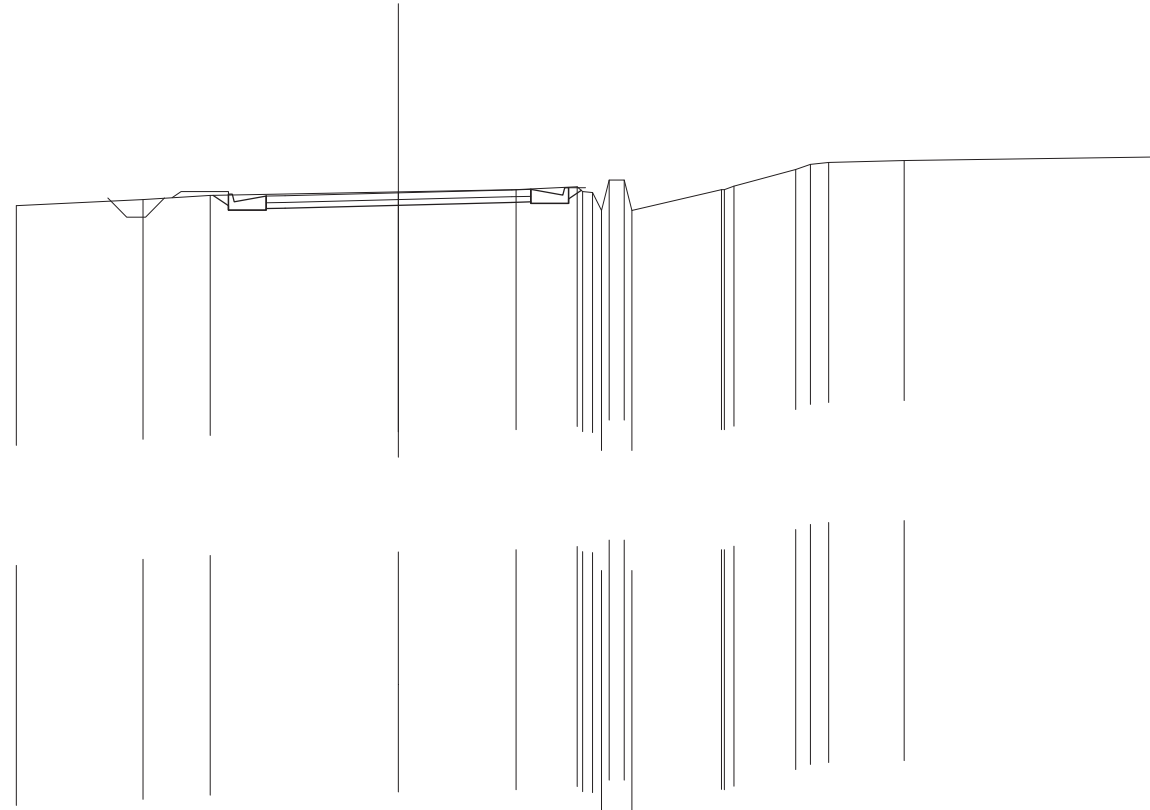

SCALA 1:200

QT. RIF. 300,000

QUOTE TERRENO	318,413	318,574	318,682	318,773	318,830	318,913	318,973	318,984	318,835	319,366	319,604	319,700
DIST. PARZIALI TERRENO	3,347	1,779	4,983	3,114	1,616	0,400	2,377	1,635	0,392	2,001	6,615	
QUOTE PROGETTO			318,684 318,292 318,412 318,712 318,523 318,625 318,645	318,420		318,425 318,507 318,837 318,467 318,887 318,467 318,587 318,814						
DIST. PARZIALI PROGETTO			0,407 0,850 0,500 3,000	3,000	0,500 0,850							
QUOTE PAVIMENTATO			318,482 318,662 318,675	318,750	318,825 318,837 318,857							
DIST. PARZIALI PAVIMENTATO			0,500 3,000	3,000	0,500							

SCAVI E BONIFICHE	
STERRO	0,449 m <sup>3</sup>
SCOTICO	5,048 m
BONIFICA	2,874 m <sup>3</sup>
RILEVATI	
RILEVATO	4,497 m <sup>3</sup>
TERRENO VEGETALE	3,994 m
SOVRASTRUTTURA STRADALE	
STRATI LEGATI	7,000 m
STRATO DI FONDAZIONE	1,443 m <sup>3</sup>

SEZIONE N. : 60  
 QT. PROGETTO: 319,012  
 DIST. PRG. : 1289,623  
 DIST. PREC. : 12,032  
 DIST. SUCC. : 15,934

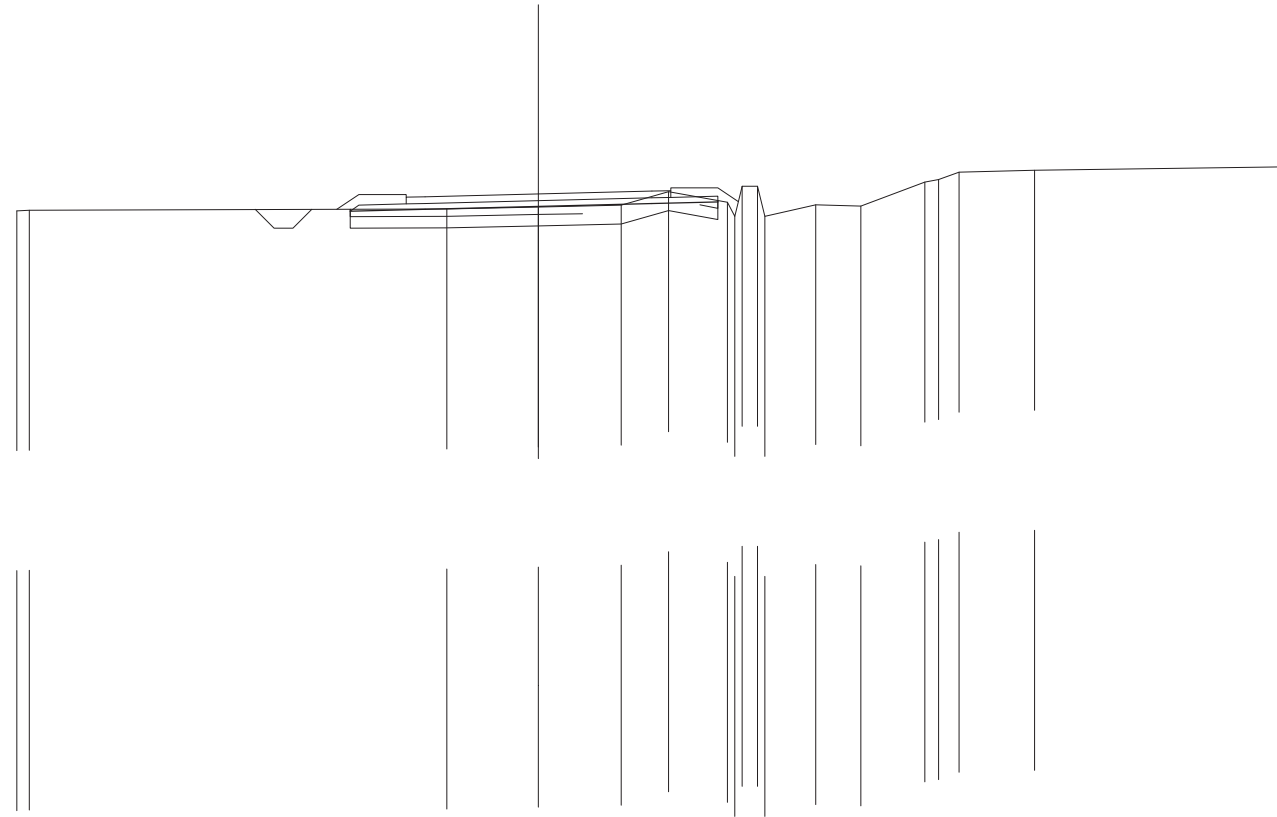

SCALA 1:200

QT. RIF. 300,000

QUOTE TERRENO	318,565 318,581		318,614	318,665	318,711	319,071	318,788 318,414 319,214 319,214 318,414	318,727	318,693	319,326 319,388 319,584	319,634	319,730
DIST. PARZIALI TERRENO		11,051	2,426	2,191	1,250	1,562	0,400 1,347	1,190	1,693	0,544 2,001	6,866	
QUOTE PROGETTO		318,557	318,607	318,682	318,757	318,801						
DIST. PARZIALI PROGETTO		1,984	3,000	3,000	1,750							
QUOTE PAVIMENTATO		318,924 318,744 318,937	319,012	319,087 318,919 319,099								
DIST. PARZIALI PAVIMENTATO		0,500	3,000	3,000	0,500							

SCAVI E BONIFICHE	
STERRO	0,077 m <sup>3</sup>
SCOTICO	7,255 m
BONIFICA	3,114 m <sup>3</sup>
RILEVATI	
RILEVATO	5,663 m <sup>3</sup>
TERRENO VEGETALE	4,280 m
SOVRASTRUTTURA STRADALE	
STRATI LEGATI	7,000 m
STRATO DI FONDAZIONE	1,459 m <sup>3</sup>

SEZIONE N. : 61  
 QT. PROGETTO: 319,354  
 DIST. PRG. : 1305,557  
 DIST. PREC. : 15,934  
 DIST. SUCC. : 28,118

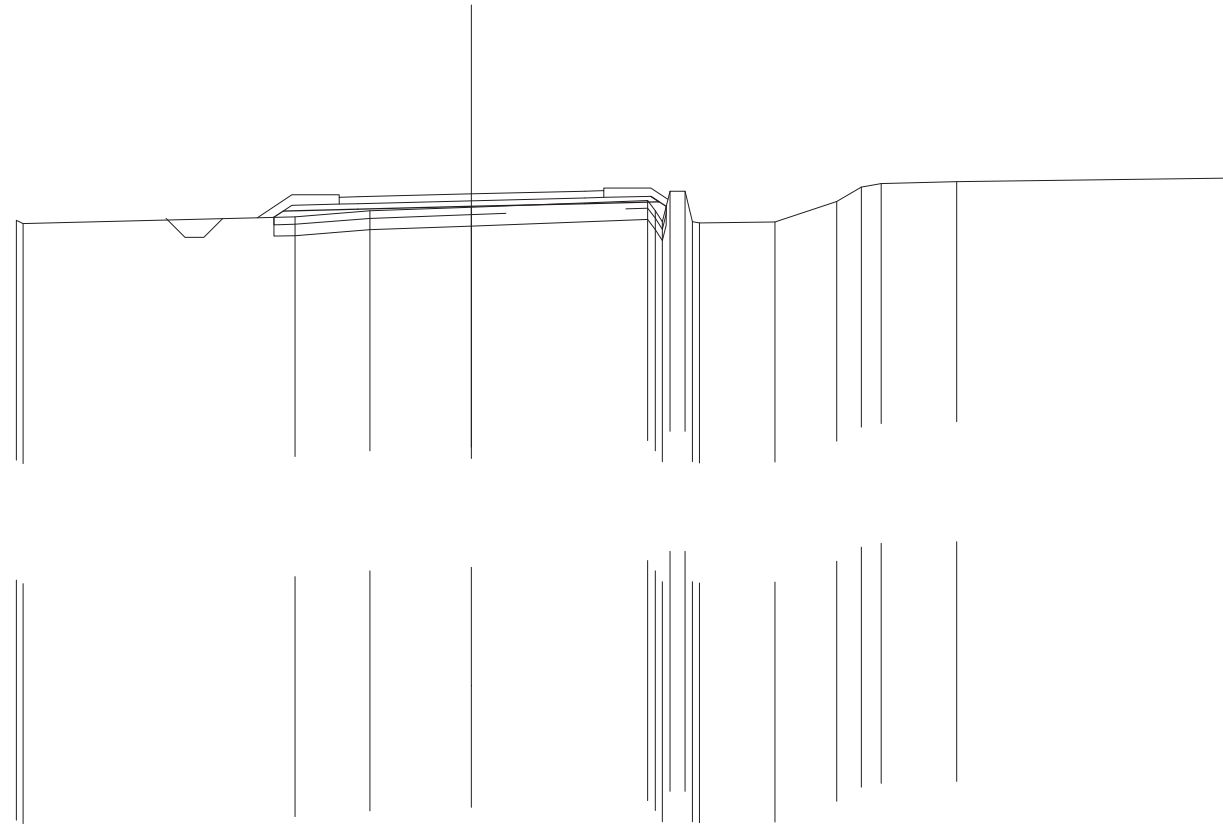

SCALA 1:200

QT. RIF. 300,000

QUOTE TERRENO	318,658 318,568		318,752	318,905	319,004		319,179 318,912 318,621 319,421 319,422 318,590	318,611		319,159 319,536 319,632	319,682	319,775
DIST. PARZIALI TERRENO		7,193	1,982	2,689	4,660	0,400	1,997	1,640	0,650	0,526	2,001	7,154
QUOTE PROGETTO			318,738 318,699	318,949	319,024		319,293 319,148 319,024					
DIST. PARZIALI PROGETTO			1,984	3,000	3,000	1,750						
QUOTE PAVIMENTATO				319,087 319,267 319,279	319,354		319,429 319,262 319,442					
DIST. PARZIALI PAVIMENTATO				0,500	3,000	3,000	0,500					













SCAVI E BONIFICHE	
STERRO	0,771 m <sup>3</sup>
SCOTICO	4,645 m
BONIFICA	2,875 m <sup>3</sup>
RILEVATI	
RILEVATO	5,029 m <sup>3</sup>
TERRENO VEGETALE	4,480 m
SOVRASTRUTTURA STRADALE	
STRATI LEGATI	7,000 m
STRATO DI FONDAZIONE	1,459 m <sup>3</sup>

SEZIONE N. : 67  
 QT. PROGETTO: 320,858  
 DIST. PRG. : 1465,329  
 DIST. PREC. : 25,000  
 DIST. SUCC. : 13,302

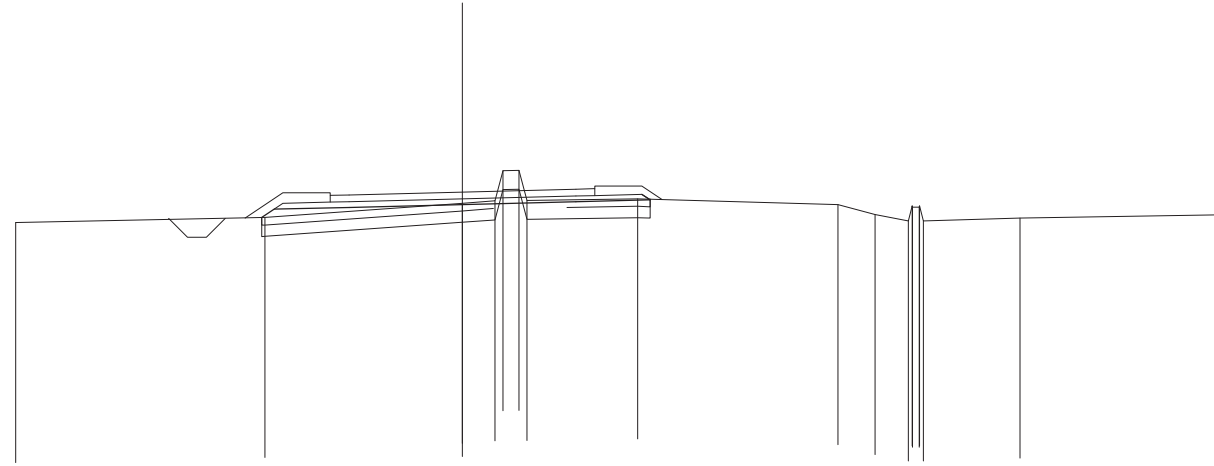

SCALA 1:200

QT. RIF. 310,000

QUOTE TERRENO	320,051	320,185	320,560	320,680	320,526	320,262	320,093	320,166	320,259
DIST. PARZIALI TERRENO	6,594	5,229	0,863	2,930	5,302	0,979	2,556	5,244	
QUOTE PROGETTO		320,183 320,404	320,453	320,528	320,603	320,797 320,653			
DIST. PARZIALI PROGETTO		1,984	3,000	3,000	1,750				
QUOTE PAVIMENTATO		320,591 320,771 320,783	320,858	320,933 320,946 320,766					
DIST. PARZIALI PAVIMENTATO		0,500	3,000	3,000	0,500				

SCAVI E BONIFICHE	
STERRO	5,227 m <sup>3</sup>
RILEVATI	
TERRENO VEGETALE	0,450 m
SOVRASTRUTTURA STRADALE	
STRATI LEGATI	7,000 m
STRATO DI FONDAZIONE	1,050 m <sup>3</sup>

SEZIONE N. : 68  
 QT. PROGETTO: 321,068  
 DIST. PROG. : 1478,631  
 DIST. PREC. : 13,302  
 DIST. SUCC. : 21,547

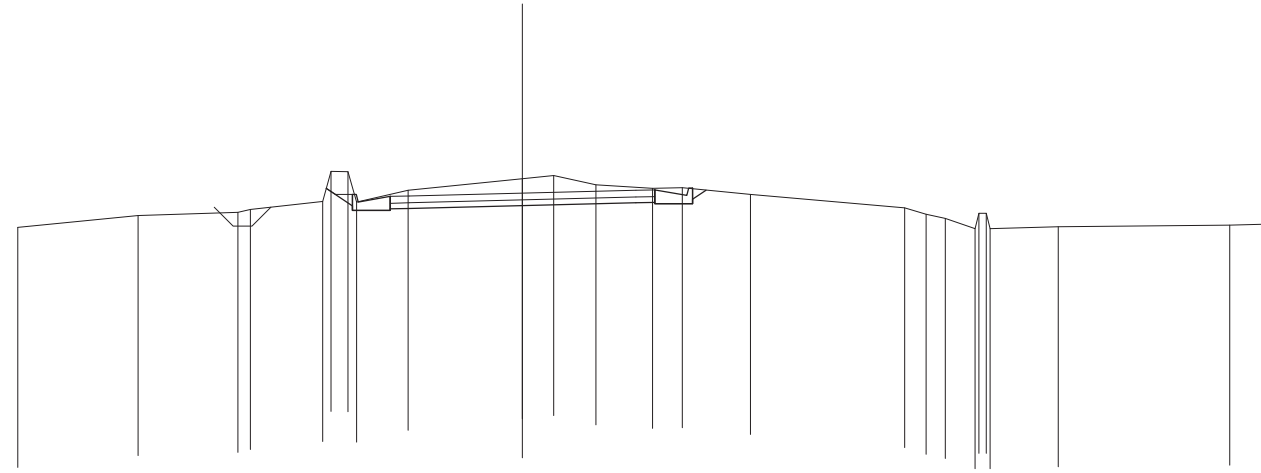

SCALA 1:200

QT. RIF. 310,000

QUOTE TERRENO	320,159	320,471	320,559 320,634	320,844 321,641 321,635 320,832	321,143	321,451 321,536	321,289	321,192 321,208	321,033	320,682 320,512 320,401	320,131 320,531 320,131	320,181	320,222 320,254
DIST. PARZIALI TERRENO	3,183	2,644	1,912	0,451 0,731 1,031 1,363	3,026	0,832 1,117	1,494	0,790	1,803	4,084	0,560 0,509 0,788	1,801	4,540 1,281
QUOTE PROGETTO				321,192 320,611 320,731 321,031 320,611 320,651 320,981 320,663	320,738		320,913 320,909 320,159 320,826 320,786 321,206 320,906 321,147						
DIST. PARZIALI PROGETTO				0,691 0,850 0,500	3,000	3,000	0,500 0,850						
QUOTE PAVIMENTATO				320,801 320,981 320,993	321,068		321,143 320,976 321,156						
DIST. PARZIALI PAVIMENTATO				0,500	3,000	3,000	0,500						





SCAVI E BONIFICHE	
SCOTICO	11,319 m
BONIFICA	3,396 m
RILEVATI	
RILEVATO	10,599 m
TERRENO VEGETALE	5,741 m
SOVRASTRUTTURA STRADALE	
STRATI LEGATI	7,000 m
STRATO DI FONDAZIONE	1,459 m

SEZIONE N. : 71  
 QT. PROGETTO: 322,024  
 DIST. PRG. : 1539,786  
 DIST. PREC. : 18,196  
 DIST. SUCC. : 25,000

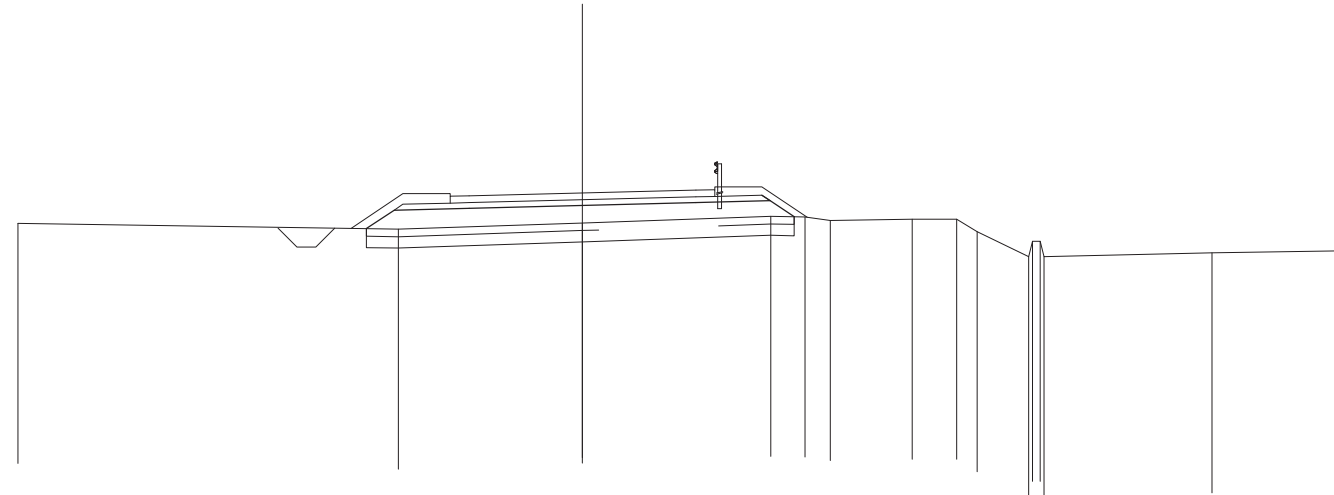

SCALA 1:200

QT. RIF. 310,000

QUOTE TERRENO	321,221	321,068	321,230	321,405	321,389	321,293	321,333	321,332	321,000	320,342	320,742	320,342	320,441	320,495
DIST. PARZIALI TERRENO	10,070	4,873	4,981	0,910	0,670	2,162	1,182	0,542	1,366	4,452	3,334			
QUOTE PROGETTO		321,081	321,569	321,619	321,694	321,769	321,962	321,818	321,394					
DIST. PARZIALI PROGETTO		0,732	1,984	3,000	3,000	1,750	0,636							
QUOTE PAVIMENTATO			321,756	321,936	321,949	322,024	322,099	322,111	321,931					
DIST. PARZIALI PAVIMENTATO			0,500	3,000	3,000	0,500								





SCAVI E BONIFICHE	
SCOTICO	12,707 m
BONIFICA	3,812 m
RILEVATI	
RILEVATO	15,461 m
TERRENO VEGETALE	7,047 m
SOVRASTRUTTURA STRADALE	
STRATI LEGATI	7,000 m
STRATO DI FONDAZIONE	1,459 m

SEZIONE N. : 73  
 QT. PROGETTO: 322,173  
 DIST. PROG. : 1589,786  
 DIST. PREC. : 25,000  
 DIST. SUCC. : 25,000

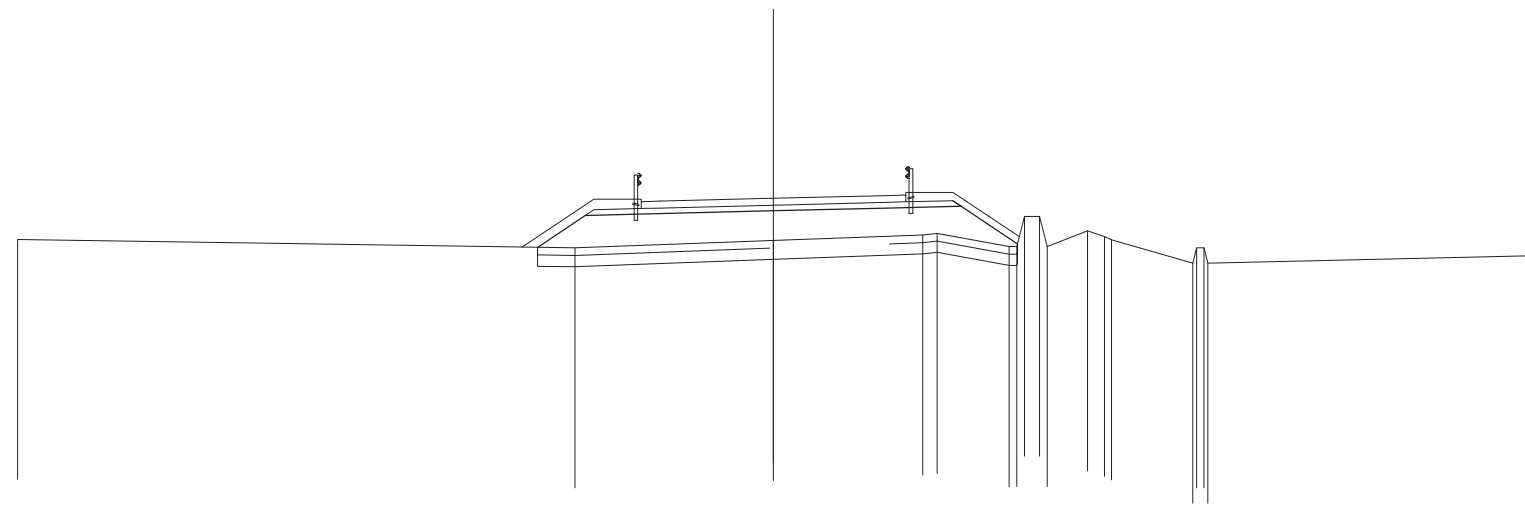

SCALA 1:200

QT. RIF. 310,000

QUOTE TERRENO	321,089	320,861	321,061	321,201 321,245	320,898 320,898 321,058 320,898 321,309 321,155 321,078	320,461 320,881 320,461	320,654
DIST. PARZIALI TERRENO	14,749	5,251	3,951	1,897	0,400 1,067 0,454	2,149	8,501
QUOTE PROGETTO	320,877	321,718	321,768	321,843	321,918	322,112 321,967	320,970
DIST. PARZIALI PROGETTO	1,262	1,984	3,000	3,000	1,750	1,495	
QUOTE PAVIMENTATO		321,905 322,085 322,098	322,173	322,248 322,260 322,080			
DIST. PARZIALI PAVIMENTATO		0,500	3,000	3,000	0,500		





SCAVI E BONIFICHE	
STERRO	0,001m <sup>3</sup>
SCOTICO	10,771m
BONIFICA	3,275m <sup>3</sup>
RILEVATI	
RILEVATO	12,709m <sup>3</sup>
TERRENO VEGETALE	5,931m
SOVRASTRUTTURA STRADALE	
STRATI LEGATI	7,000m
STRATO DI FONDAZIONE	1,459m <sup>3</sup>

SEZIONE N. : 76  
 QT. PROGETTO: 321,755  
 DIST. PRG. : 1655,486  
 DIST. PREC. : 20,132  
 DIST. SUCC. : 20,276

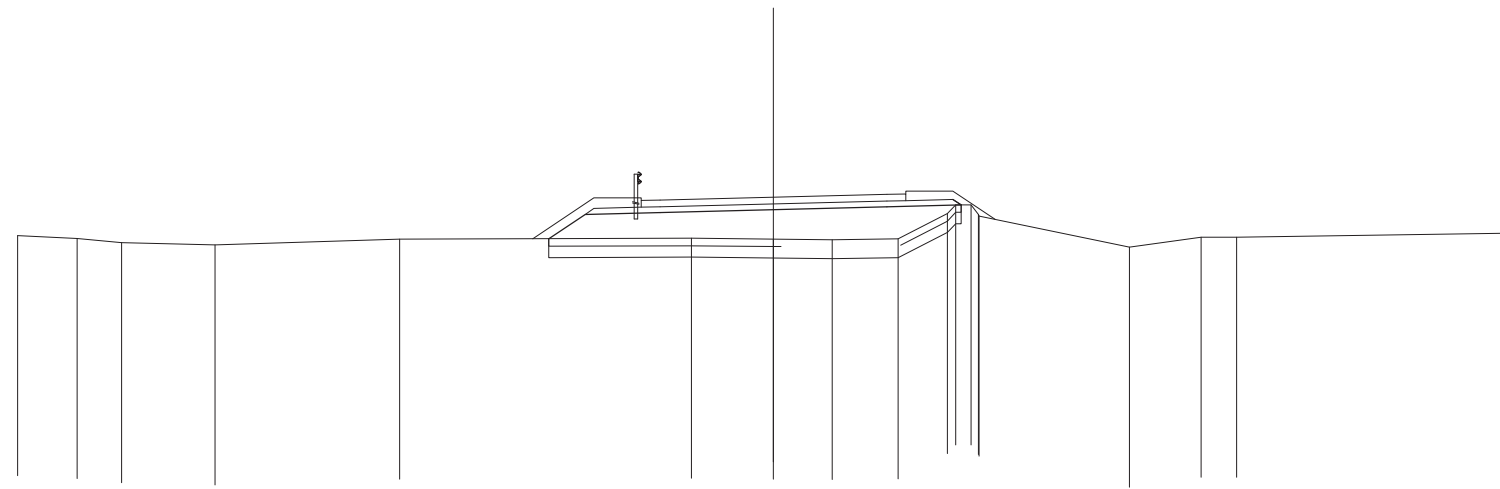

SCALA 1:200

QT. RIF. 310,000

QUOTE TERRENO	320,740	320,661	320,552	320,494	320,640	320,671	320,648	320,631	320,649	321,321	321,553	321,299	321,257	320,428	320,696	320,696	320,804
DIST. PARZIALI TERRENO	1,572	1,178	2,472	4,888	7,722	2,168	1,556	1,745	1,308	0,400	3,978	1,905	0,939	7,455			
QUOTE PROGETTO					320,656	321,300	321,350	321,425	321,500	321,693	321,549						
DIST. PARZIALI PROGETTO					0,966	1,984	3,000	3,000	1,750								
QUOTE PAVIMENTATO						321,667	321,487	321,680	321,755	321,830	321,662	321,842					
DIST. PARZIALI PAVIMENTATO						0,500	3,000	3,000	0,500								

SCAVI E BONIFICHE	
SCOTICO	11,524 m
BONIFICA	3,457 m
RILEVATI	
RILEVATO	13,391 m
TERRENO VEGETALE	6,126 m
SOVRASTRUTTURA STRADALE	
STRATI LEGATI	7,000 m
STRATO DI FONDAZIONE	1,459 m

SEZIONE N. : 77  
 QT. PROGETTO: 321,626  
 DIST. PROG. : 1675,761  
 DIST. PREC. : 20,276  
 DIST. SUCC. : 14,514

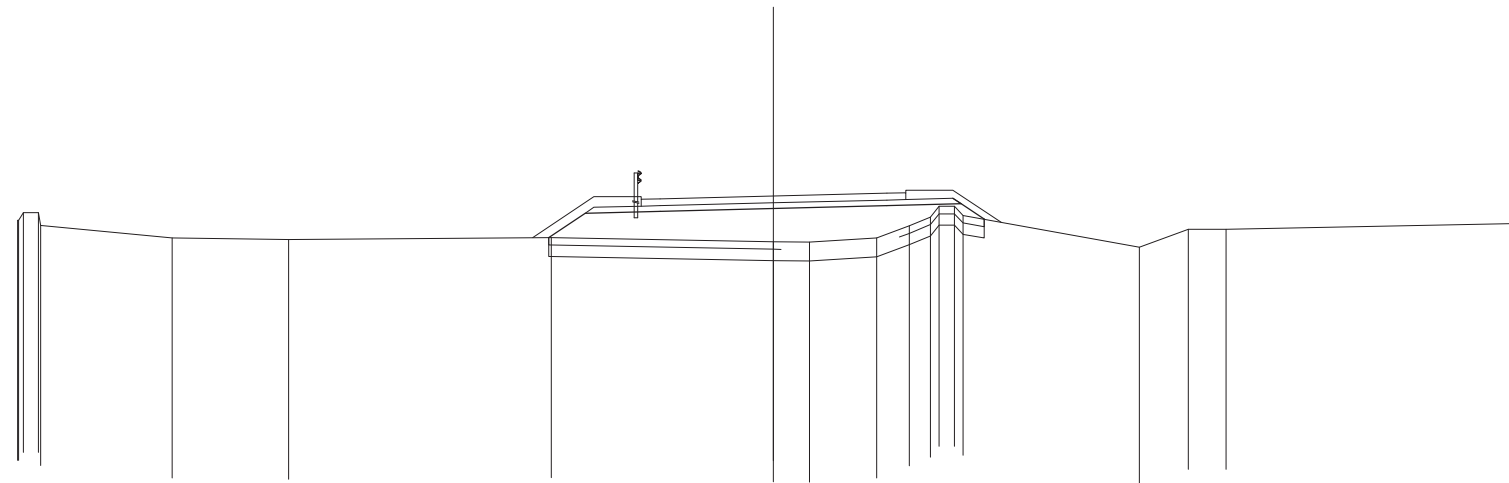

SCALA 1:200

QT. RIF. 310,000

QUOTE TERRENO	320,981 320,981 320,981 320,848	320,518	320,478	320,529	320,418 320,410	320,515 320,835 321,070 321,353 321,420 321,114	320,270	320,743	320,743	320,899
DIST. PARZIALI TERRENO	0,400 3,484	3,077	6,955	5,879	0,956 1,776	0,861 0,564 0,400	4,663	1,298	1,000	7,686
QUOTE PROGETTO				320,528 321,171	321,296	321,371 321,564 321,420 321,013				
DIST. PARZIALI PROGETTO				0,964 1,984	3,000	3,000 1,750				
QUOTE PAVIMENTATO					321,626	321,701 321,533 321,713				
DIST. PARZIALI PAVIMENTATO					0,500 3,000	3,000				



SCAVI E BONIFICHE	
SCOTICO	11,884 m
BONIFICA	3,565 m
RILEVATI	
RILEVATO	11,604 m
TERRENO VEGETALE	6,275 m
SOVRASTRUTTURA STRADALE	
STRATI LEGATI	7,000 m
STRATO DI FONDAZIONE	1,459 m

SEZIONE N. : 79  
 QT. PROGETTO: 321,392  
 DIST. PROG. : 1715,275  
 DIST. PREC. : 25,000  
 DIST. SUCC. : 25,000

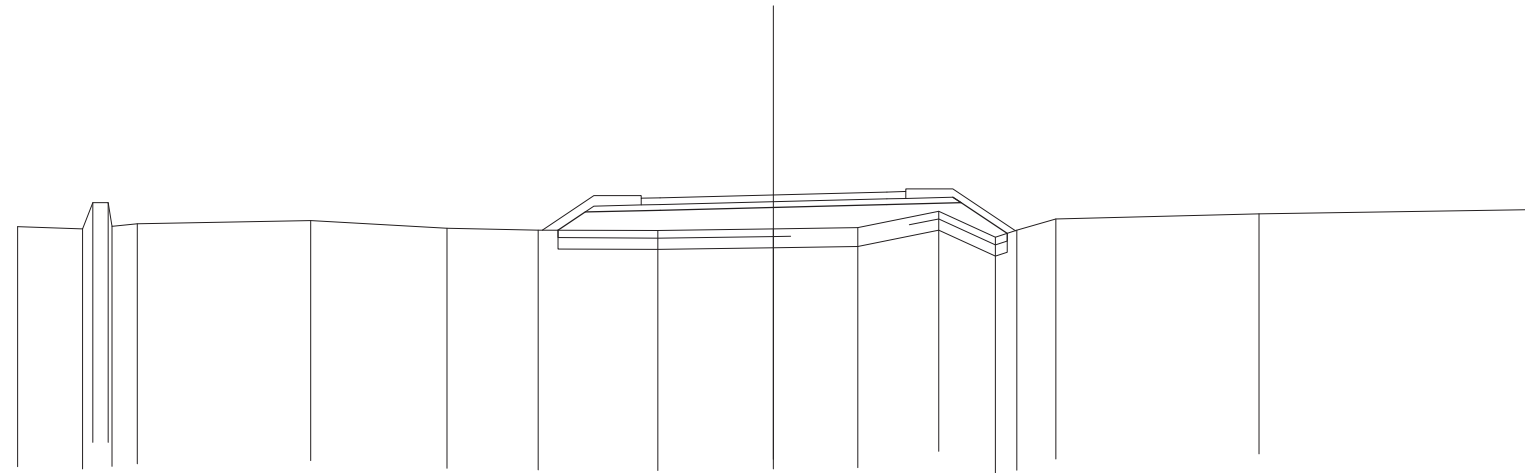

SCALA 1:200

QT. RIF. 310,000

QUOTE TERRENO	320,550	320,495	320,708	320,507	320,462	320,450	320,492	320,524	320,956	320,271	320,457	320,754	320,891	320,997
DIST. PARZIALI TERRENO	1,720	0,400	4,588	3,610	2,408	3,170	3,058	2,234	2,141	1,499	0,570	1,029	5,377	7,145
QUOTE PROGETTO						320,460	320,937			321,137				
DIST. PARZIALI PROGETTO						0,715	1,984	3,000	3,000	1,750	1,219			
QUOTE PAVIMENTATO						321,124	321,304	321,317	321,392	321,467	321,479	321,299		
DIST. PARZIALI PAVIMENTATO						0,500	3,000	3,000	3,000	0,500				



SCAVI E BONIFICHE	
SCOTICO	11,182 m
BONIFICA	3,355 m <sup>3</sup>
RILEVATI	
RILEVATO	11,554 m <sup>3</sup>
TERRENO VEGETALE	5,671 m
SOVRASTRUTTURA STRADALE	
STRATI LEGATI	7,000 m
STRATO DI FONDAZIONE	1,459 m <sup>3</sup>

SEZIONE N. : 80  
 QT. PROGETTO: 321,378  
 DIST. PRG. : 1740,275  
 DIST. PREC. : 25,000  
 DIST. SUCC. : 25,000

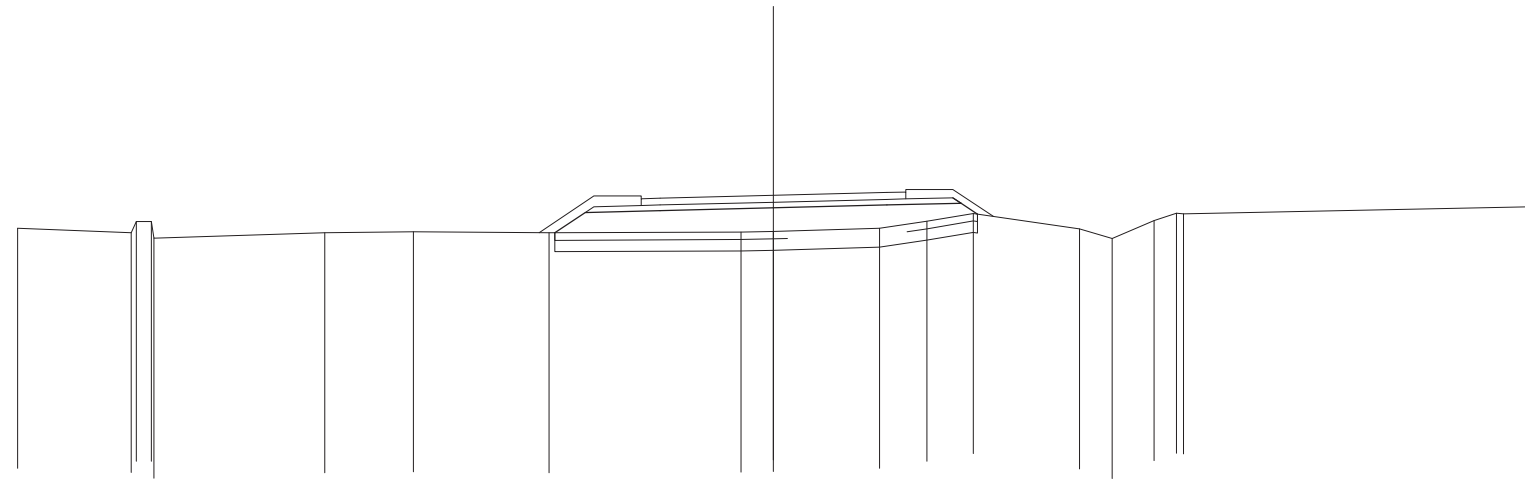

SCALA 1:200

QT. RIF. 310,000

QUOTE TERRENO	320,508	320,394 320,690 320,690 320,243	320,387	320,414	320,391	320,408 320,427	320,509	320,692	320,900	320,491 320,237	320,713 320,906 320,891	321,078			
DIST. PARZIALI TERRENO	3,005	0,401	4,523	2,351	3,591	5,076	0,859	2,811	1,250	1,225	2,813	0,869	1,108	0,592	9,143
QUOTE PROGETTO						320,391 320,924	320,973	321,048	321,123	321,317 321,173 320,884					
DIST. PARZIALI PROGETTO						0,799	1,984	3,000	3,000	1,750	0,433				
QUOTE PAVIMENTATO							321,111 321,291 321,303	321,378	321,453 321,286 321,466						
DIST. PARZIALI PAVIMENTATO							0,500	3,000	3,000	0,500					

SCAVI E BONIFICHE	
SCOTICO	11,203m
BONIFICA	3,361m
RILEVATI	
RILEVATO	10,032m
TERRENO VEGETALE	5,653m
SOVRASTRUTTURA STRADALE	
STRATI LEGATI	7,008m
STRATO DI FONDAZIONE	1,460m

SEZIONE N. : 81  
 QT. PROGETTO: 321,372  
 DIST. PROG. : 1765,275  
 DIST. PREC. : 25,000  
 DIST. SUCC. : 24,800

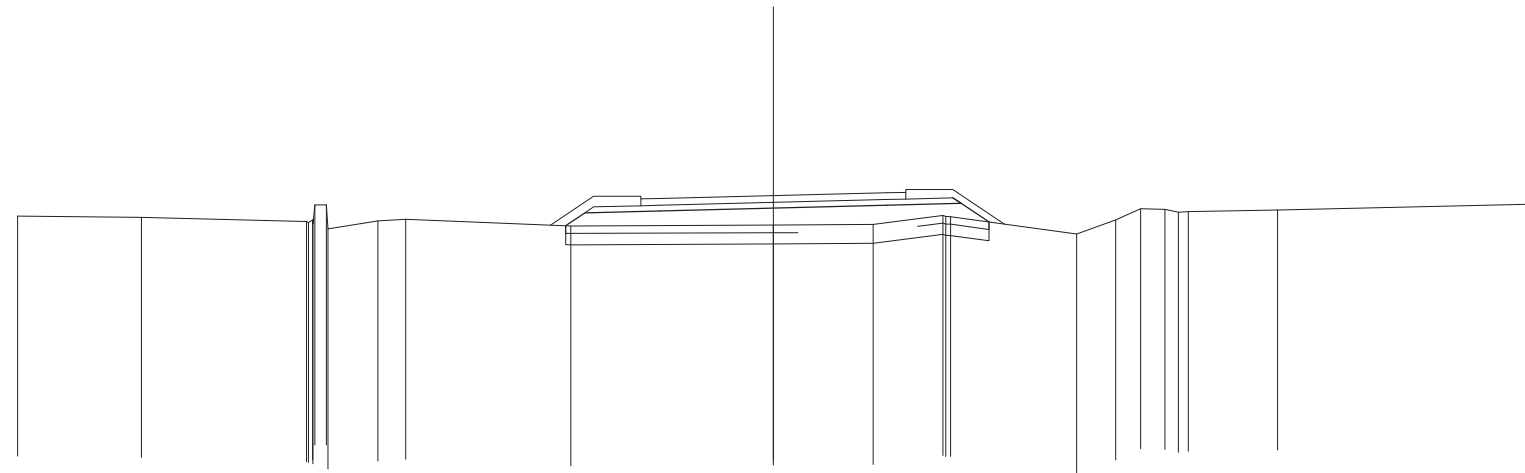

SCALA 1:200

QT. RIF. 310,000

QUOTE TERRENO		320,827	320,795	320,693 320,795 320,659 321,130 320,492 320,701 320,749	320,572	320,590	320,607	320,845 320,821 320,817	320,356	320,732	321,023 321,009 320,929 320,953	320,990	321,142
DIST. PARZIALI TERRENO		3,270	4,372	1,318 0,738	4,364	5,366	2,639	1,850	3,333	1,034	0,664 0,640	2,362	6,654
QUOTE PROGETTO						320,577 320,918	320,967	321,042	321,117	321,311 321,167 320,677			
DIST. PARZIALI PROGETTO						0,510	1,991	3,000	3,000	1,750	0,734		
QUOTE PAVIMENTATO							321,105 321,285 321,297	321,372	321,447 321,280 321,460				
DIST. PARZIALI PAVIMENTATO							0,508	3,000	3,000	0,500			





SCAVI E BONIFICHE	
SCOTICO	10,439m
BONIFICA	3,132m
RILEVATI	
RILEVATO	9,213m
TERRENO VEGETALE	4,595m
SOVRASTRUTTURA STRADALE	
STRATI LEGATI	7,000m
STRATO DI FONDAZIONE	1,459m

SEZIONE N. : 84  
 QT. PROGETTO: 321,354  
 DIST. PRG. : 1841,767  
 DIST. PREC. : 25,966  
 DIST. SUCC. : 12,426

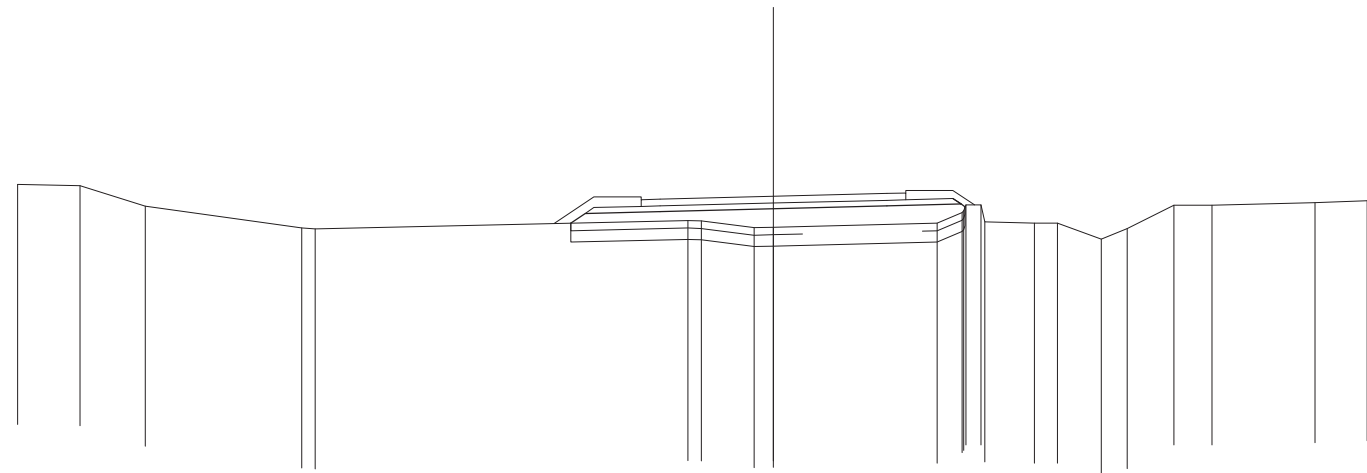

SCALA 1:200

QT. RIF. 310,000

QUOTE TERRENO	321,667	321,638	321,094	320,516 320,498	320,714 320,700	320,524 320,537	320,644 320,923 320,978 321,129 321,129 320,643 320,641 320,646	320,217 320,498	321,122 321,122	321,182 321,234 321,224		
DIST. PARZIALI TERRENO	1,645	1,730	4,140	9,864	1,402	0,510	4,331	0,662 0,400	1,312 0,612 1,158	0,688 1,239	1,001 2,728	1,381 0,422
QUOTE PROGETTO				320,645 320,899	320,949	321,024	321,099	321,293 321,148 321,077				
DIST. PARZIALI PROGETTO				1,984	3,000	3,000	1,750					
QUOTE PAVIMENTATO		321,087 321,267 321,279			321,354		321,429 321,442 321,262					
DIST. PARZIALI PAVIMENTATO		0,500	3,000		3,000		0,500					

SCAVI E BONIFICHE	
SCOTICO	10,595 m
BONIFICA	3,179 m
RILEVATI	
RILEVATO	9,436 m
TERRENO VEGETALE	4,673 m
SOVRASTRUTTURA STRADALE	
STRATI LEGATI	7,000 m
STRATO DI FONDAZIONE	1,459 m

SEZIONE N. : 85  
 QT. PROGETTO: 321,351  
 DIST. PROG. : 1854,193  
 DIST. PREC. : 12,426  
 DIST. SUCC. : 13,564

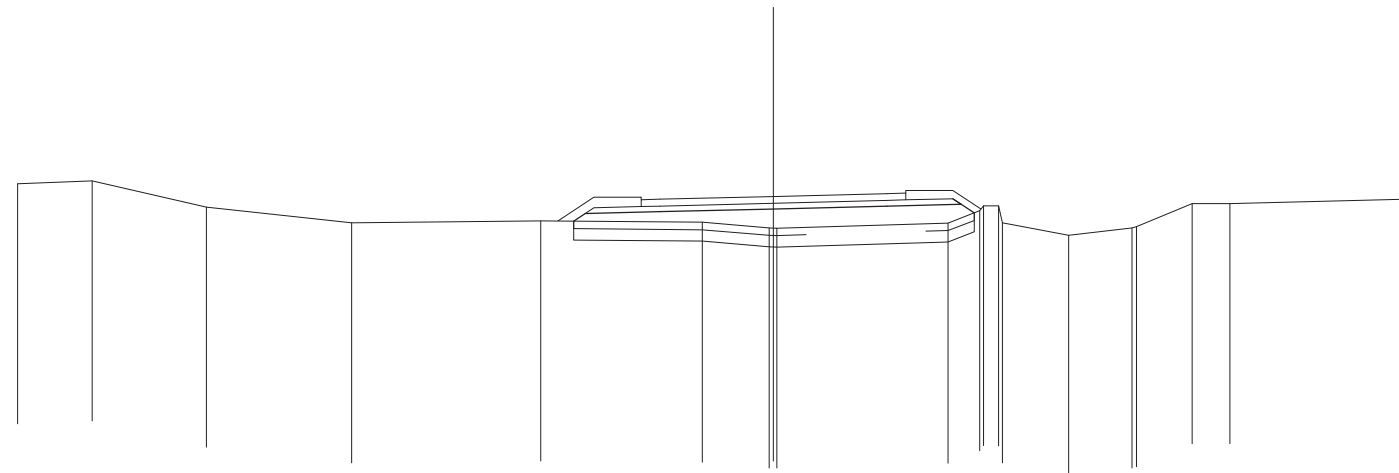

SCALA 1:200

QT. RIF. 310,000

QUOTE TERRENO	321,683	321,764	321,068	320,651	320,705	320,669	320,519 320,513	320,648	320,320	320,521 320,551	321,160	321,160	321,282
DIST. PARZIALI TERRENO	1,966	3,028	3,846	5,005	4,276	1,768	4,535	0,835	1,750	1,680	1,473	1,001	4,733
QUOTE PROGETTO					320,697 320,896	320,946	321,021	321,096	321,290 321,149 320,914				
DIST. PARZIALI PROGETTO					1,984	3,000	3,000	1,750					
QUOTE PAVIMENTATO						321,084 321,264 321,276	321,351	321,426 321,539 321,439					
DIST. PARZIALI PAVIMENTATO						0,500	3,000	3,000	0,500				

SCAVI E BONIFICHE	
SCOTICO	10,592 m
BONIFICA	3,178 m
RILEVATI	
RILEVATO	9,783 m
TERRENO VEGETALE	4,674 m
SOVRASTRUTTURA STRADALE	
STRATI LEGATI	7,000 m
STRATO DI FONDAZIONE	1,459 m

SEZIONE N. : 86  
 QT. PROGETTO: 321,348  
 DIST. PRG. : 1867,757  
 DIST. PREC. : 13,564  
 DIST. SUCC. : 26,010

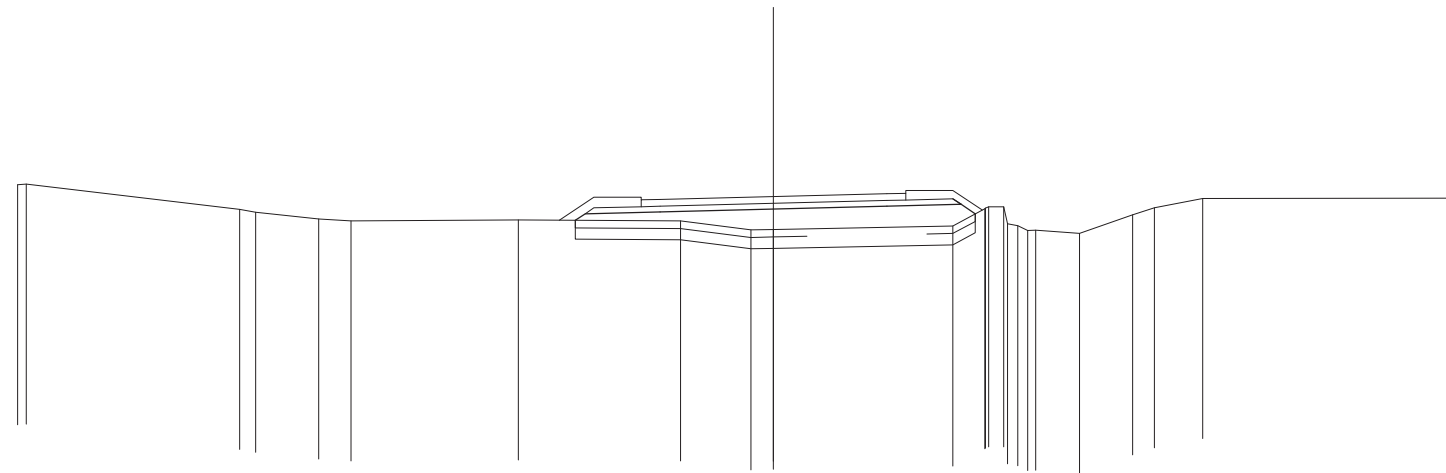

SCALA 1:200

QT. RIF. 310,000

QUOTE TERRENO	321,661 321,673	321,007 320,930	320,751 320,703	320,726	320,700	320,465 320,479	320,569 321,024 321,045 321,079 320,529 320,576 320,450 320,371	320,863 321,048 321,299	321,303	
DIST. PARZIALI TERRENO	5,652	0,424 1,667	0,857	4,426	4,294	1,857 0,599	4,746	0,848 0,400	1,165 1,398 0,582 1,278	6,642
QUOTE PROGETTO				320,717 320,693	320,943	321,018	321,093	321,287 321,142 320,896		
DIST. PARZIALI PROGETTO				1,984	3,000	3,000	1,750			
QUOTE PAVIMENTATO				321,080 321,260 321,273	321,348	321,423 321,535 321,435				
DIST. PARZIALI PAVIMENTATO				0,500	3,000	3,000	0,500			

SCAVI E BONIFICHE	
SCOTICO	10,643m
BONIFICA	3,193m
RILEVATI	
RILEVATO	9,265m
TERRENO VEGETALE	4,905m
SOVRASTRUTTURA STRADALE	
STRATI LEGATI	7,000m
STRATO DI FONDAZIONE	1,459m

SEZIONE N. : 87  
 QT. PROGETTO: 321,342  
 DIST. PRG. : 1893,768  
 DIST. PREC. : 26,010  
 DIST. SUCC. : 25,103

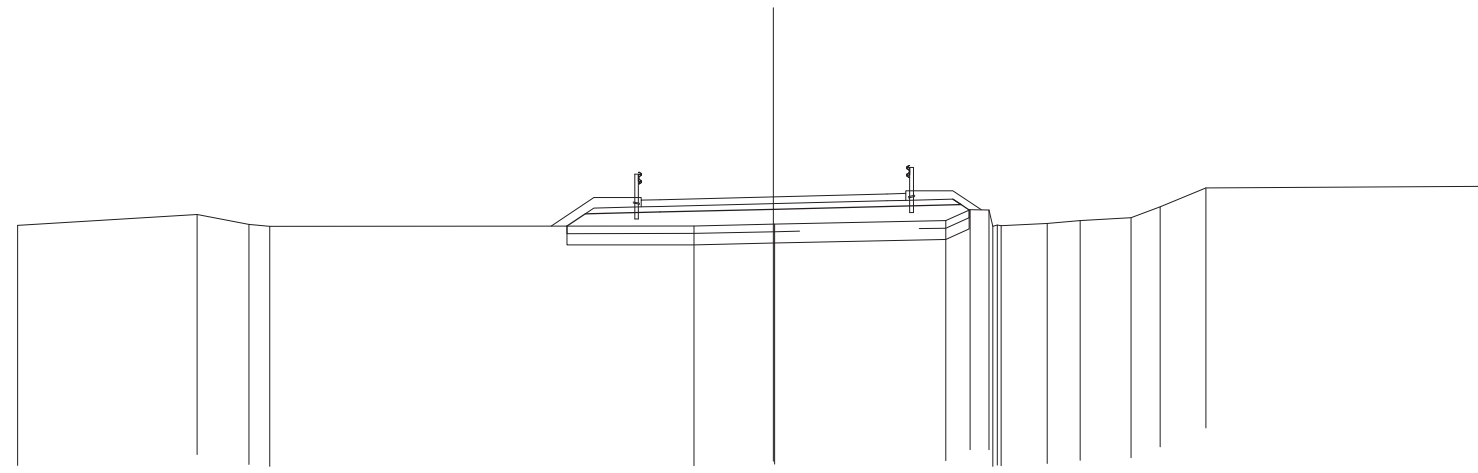

SCALA 1:200

QT. RIF. 310,000

QUOTE TERRENO	320,584	320,876	320,613	320,562	320,572	320,619	320,620	320,711	321,001	320,725	320,590	320,576	320,632	320,715	320,788	321,076	321,573	321,614
DIST. PARZIALI TERRENO	4,749	1,372	0,549		11,226	2,103	4,531	0,641	0,500	0,223	0,869	1,347	0,770	1,209	7,408			
QUOTE PROGETTO					320,569	320,887	320,937	321,012	321,087	321,280	321,130	320,992						
DIST. PARZIALI PROGETTO					0,477	1,984	3,000	3,000	1,750									
QUOTE PAVIMENTATO							321,074	321,342	321,417	321,254	321,267							
DIST. PARZIALI PAVIMENTATO							0,500	3,000	3,000	0,500								









SCAVI E BONIFICHE	
SCOTICO	11,583 m
BONIFICA	3,475 m
RILEVATI	
RILEVATO	11,492 m
TERRENO VEGETALE	6,055 m
SOVRASTRUTTURA STRADALE	
STRATI LEGATI	7,000 m
STRATO DI FONDAZIONE	1,459 m

SEZIONE N. : 91  
 QT. PROGETTO: 322,232  
 DIST. PRG. : 1999,376  
 DIST. PREC. : 24,389  
 DIST. SUCC. : 18,895

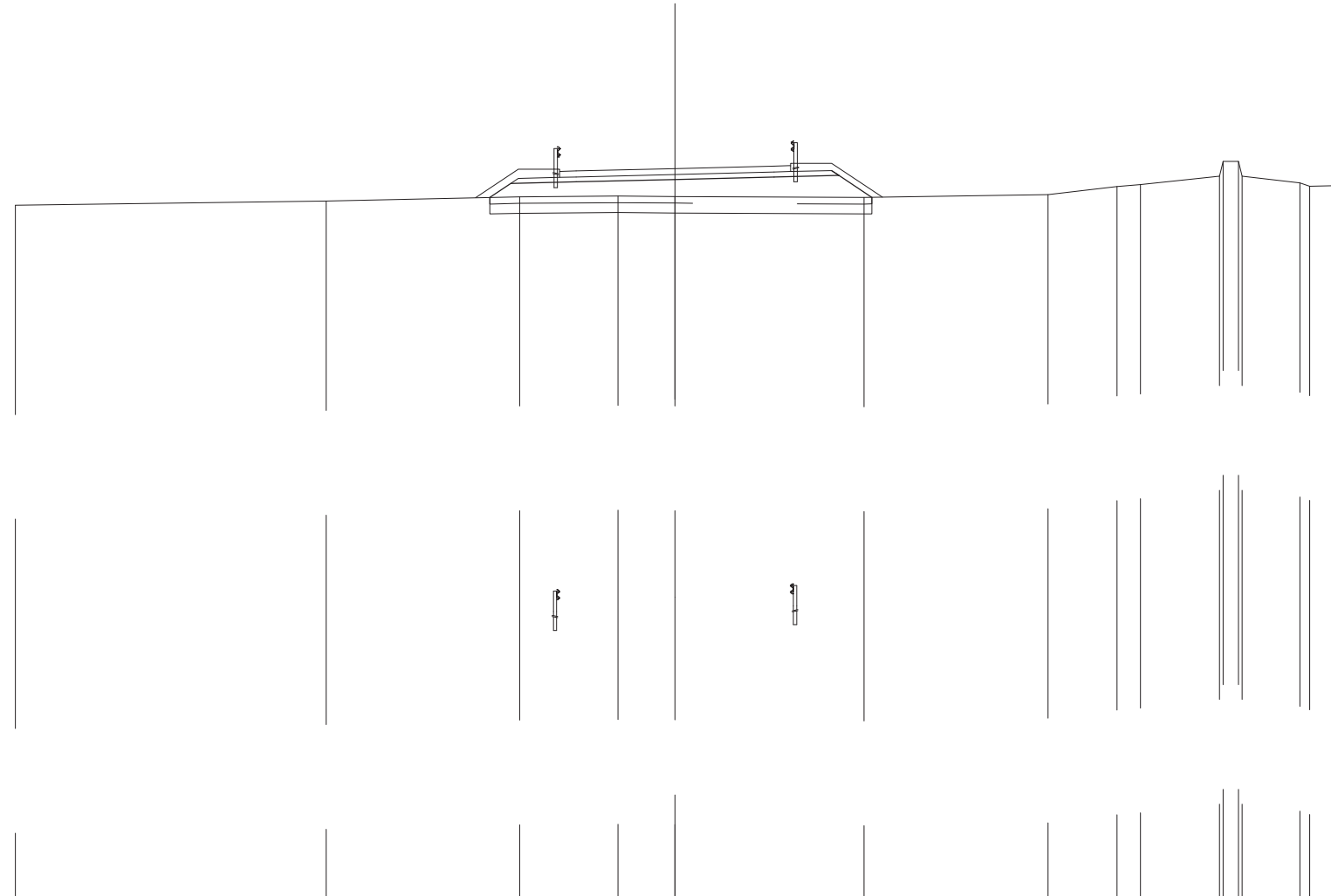

SCALA 1:200

QT. RIF. 300,000

QUOTE TERRENO	321,122	321,242	321,377	321,396	321,384	321,355	321,441	321,685	321,745	322,002	322,456	322,002	321,797	321,694	321,708
DIST. PARZIALI TERRENO	9,421	5,869	2,977	1,733	5,731	5,584	2,088	0,712	2,392	0,461	1,753	0,755			
QUOTE PROGETTO			321,356	321,778	321,827	321,902	321,977	322,171	322,026	321,359					
DIST. PARZIALI PROGETTO			0,632	1,984	3,000	3,000	1,750	1,001							
QUOTE PAVIMENTATO				322,145	321,965	322,232	322,307	322,140	322,320						
DIST. PARZIALI PAVIMENTATO				0,500	3,000	3,000	0,500								

SCAVI E BONIFICHE	
SCOTICO	11,052 m
BONIFICA	2,210 m
RILEVATI	
RILEVATO	8,296 m
TERRENO VEGETALE	5,412 m
SOVRASTRUTTURA STRADALE	
STRATI LEGATI	7,000 m
STRATO DI FONDAZIONE	1,459 m

SEZIONE N. : 92  
 QT. PROGETTO: 322,511  
 DIST. PROG. : 2018,270  
 DIST. PREC. : 18,895  
 DIST. SUCC. : 24,721

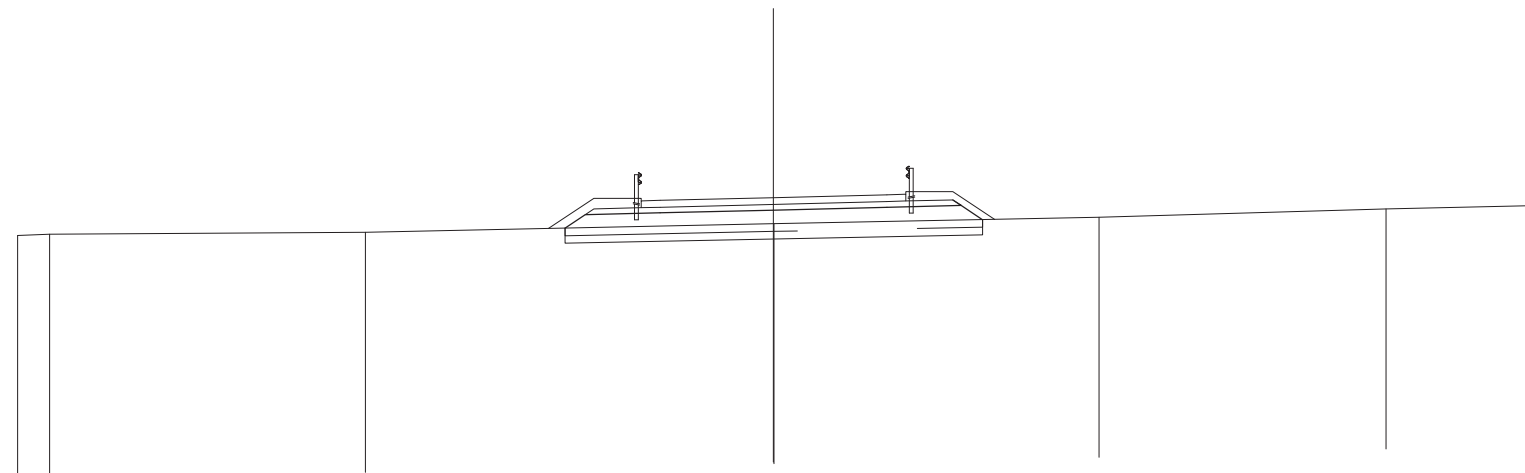

SCALA 1:200

QT. RIF. 310,000

QUOTE TERRENO	321,510	321,540	321,590	321,817	321,987	322,212	322,293
DIST. PARZIALI TERRENO	0,839	8,365	10,796	8,602	7,595	3,786	
QUOTE PROGETTO				321,701 322,057	322,106	322,181	322,256 322,450 322,305 321,928
DIST. PARZIALI PROGETTO				0,533 1,984	3,000	3,000	1,750 0,568
QUOTE PAVIMENTATO				322,244 322,424 322,436	322,511	322,586 322,419 322,599	
DIST. PARZIALI PAVIMENTATO				0,500 3,000	3,000	0,500	

SCAVI E BONIFICHE	
SCOTICO	10,308m
BONIFICA	2,062m
RILEVATI	
RILEVATO	5,418m
TERRENO VEGETALE	4,512m
SOVRASTRUTTURA STRADALE	
STRATI LEGATI	7,000m
STRATO DI FONDAZIONE	1,459m

SEZIONE N. : 93  
 QT. PROGETTO: 322,876  
 DIST. PROG. : 2042,992  
 DIST. PREC. : 24,721  
 DIST. SUCC. : 23,738

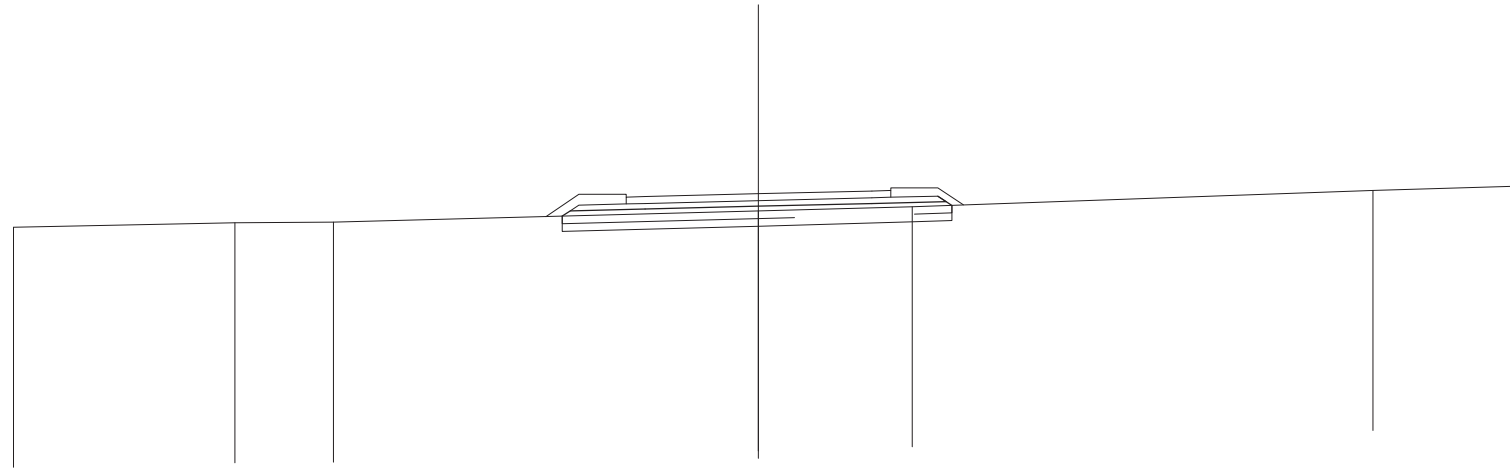

SCALA 1:200

QT. RIF. 310,000

QUOTE TERRENO	321,989	322,112	322,127		322,419	322,533		322,966	323,073
DIST. PARZIALI TERRENO		5,861	2,612	11,246		4,070	12,195		3,735
QUOTE PROGETTO					322,284 322,422	322,471	322,546	322,621	322,815 322,870 322,570
DIST. PARZIALI PROGETTO					1,984	3,000	3,000	1,750	
QUOTE PAVIMENTATO					322,789 322,609 322,801	322,876		322,951 322,784 322,964	
DIST. PARZIALI PAVIMENTATO					0,500	3,000	3,000	0,500	

SCAVI E BONIFICHE	
SCOTICO	11,073 m
BONIFICA	2,215 m
RILEVATI	
RILEVATO	8,315 m
TERRENO VEGETALE	5,432 m
SOVRASTRUTTURA STRADALE	
STRATI LEGATI	7,000 m
STRATO DI FONDAZIONE	1,459 m

SEZIONE N. : 94  
 QT. PROGETTO: 323,227  
 DIST. PRG. : 2066,730  
 DIST. PREC. : 23,738  
 DIST. SUCC. : 25,000

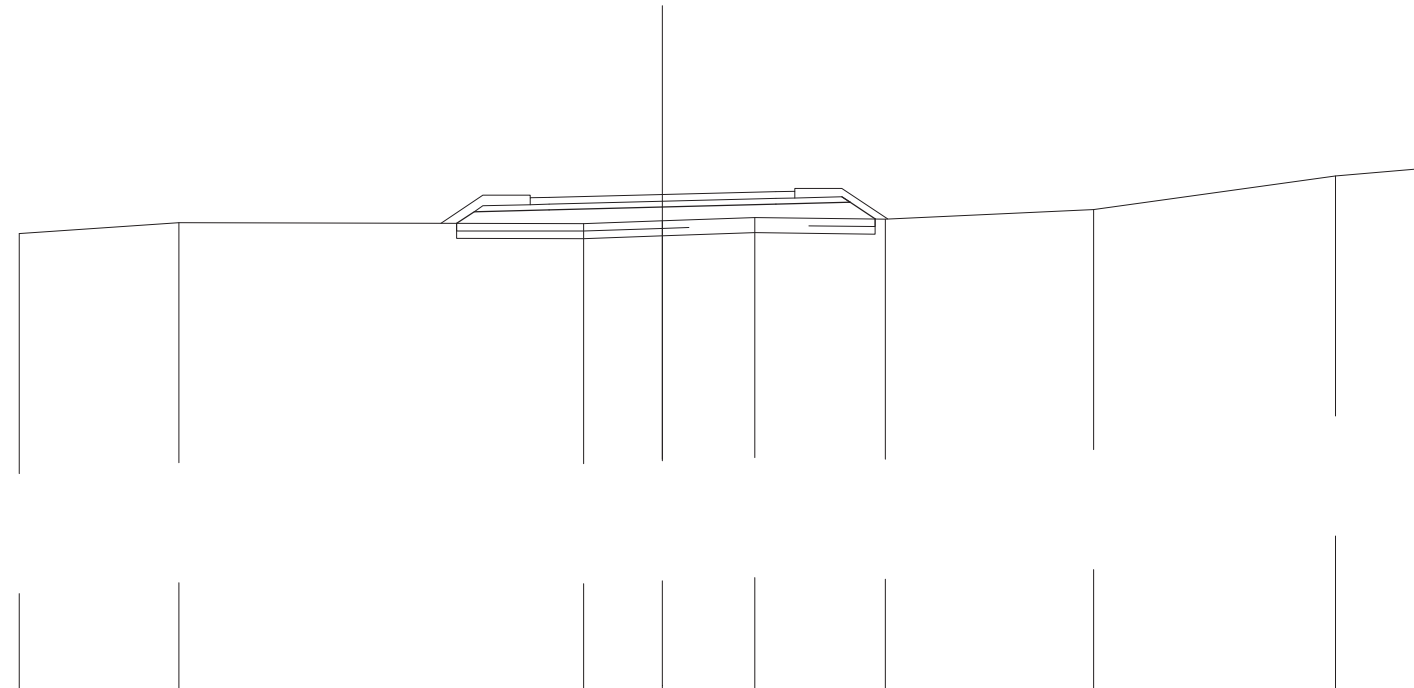

SCALA 1:200

QT. RIF. 310,000

QUOTE TERRENO		322,192	322,479		322,458	322,531	322,616	322,577	322,829	323,717	323,907
DIST. PARZIALI TERRENO		4,224	10,713		2,086	2,441	3,461	5,508	6,403	2,187	
QUOTE PROGETTO				322,464 322,772	322,822	322,897	322,972	323,166 323,021 322,580			
DIST. PARZIALI PROGETTO				0,462 1,984	3,000	3,000	1,750	0,661			
QUOTE PAVIMENTATO				322,959 323,139 323,152	323,227	323,302 323,134 323,314					
DIST. PARZIALI PAVIMENTATO				0,500 3,000	3,000	0,500					

SCAVI E BONIFICHE	
SCOTICO	10,605 m
BONIFICA	2,121 m
RILEVATI	
RILEVATO	6,890 m
TERRENO VEGETALE	4,857 m
SOVRASTRUTTURA STRADALE	
STRATI LEGATI	7,000 m
STRATO DI FONDAZIONE	1,459 m

SEZIONE N. : 95  
 QT. PROGETTO: 323,596  
 DIST. PRG. : 2091,730  
 DIST. PREC. : 25,000  
 DIST. SUCC. : 14,623

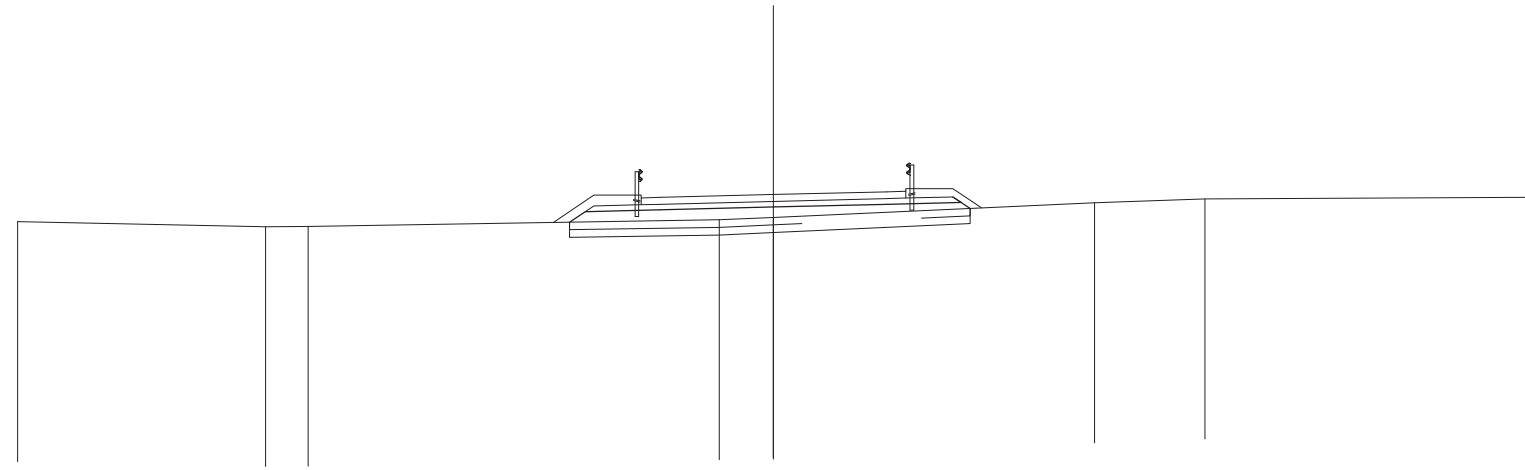

SCALA 1:200

QT. RIF. 310,000

QUOTE TERRENO		322,880		322,748	322,756				322,926	322,992				323,381		323,482			323,527			
DIST. PARZIALI TERRENO			6,563		1,123		10,879			1,435			8,499		2,918		8,583					
QUOTE PROGETTO									322,864	323,142			323,191				323,266		323,341	323,535	323,590	323,230
DIST. PARZIALI PROGETTO									0,415	1,984		3,000		3,000		1,750						
QUOTE PAVIMENTATO											323,509	323,329	323,521				323,596		323,671	323,504	323,684	
DIST. PARZIALI PAVIMENTATO											0,500		3,000		3,000				0,500			



SCAVI E BONIFICHE	
SCOTICO	11,961 m
BONIFICA	2,392 m
RILEVATI	
RILEVATO	13,075 m
TERRENO VEGETALE	6,466 m
SOVRASTRUTTURA STRADALE	
STRATI LEGATI	7,000 m
STRATO DI FONDAZIONE	1,459 m

SEZIONE N. : 96  
 QT. PROGETTO: 323,812  
 DIST. PROG. : 2106,353  
 DIST. PREC. : 14,623  
 DIST. SUCC. : 32,027

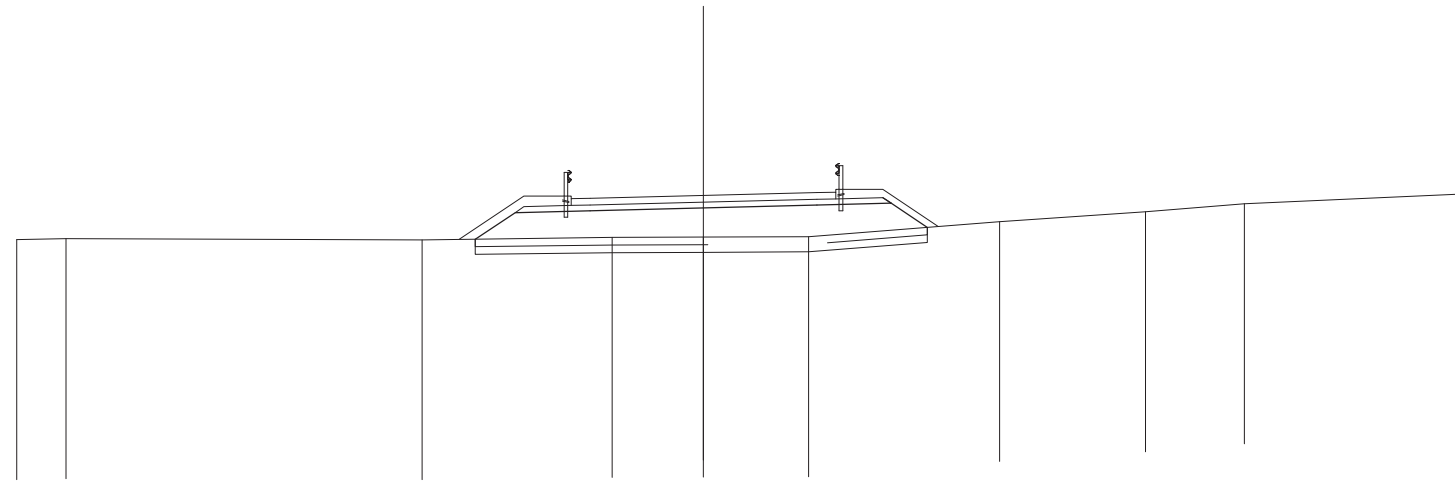

SCALA 1:200

QT. RIF. 310,000

QUOTE TERRENO		322,640	322,671		322,638	322,699	322,707	322,717		323,121	323,375	323,592		323,844
DIST. PARZIALI TERRENO		1,304		9,430		5,028	2,416	2,780		5,060	3,856	2,617		5,686
QUOTE PROGETTO						322,655	323,358	323,407		323,482	323,557	323,751	323,606	322,968
DIST. PARZIALI PROGETTO						1,053	1,984	3,000		3,000	1,750	0,957		
QUOTE PAVIMENTATO							323,545	323,725	323,737		323,812	323,887	323,720	323,900
DIST. PARZIALI PAVIMENTATO							0,500	3,000		3,000	0,500			

SCAVI E BONIFICHE	
SCOTICO	12,393 m
BONIFICA	2,479 m
RILEVATI	
RILEVATO	15,540 m
TERRENO VEGETALE	6,980 m
SOVRASTRUTTURA STRADALE	
STRATI LEGATI	7,000 m
STRATO DI FONDAZIONE	1,459 m

SEZIONE N. : 97  
 QT. PROGETTO: 324,285  
 DIST. PROG. : 2138,380  
 DIST. PREC. : 32,027  
 DIST. SUCC. : 20,891

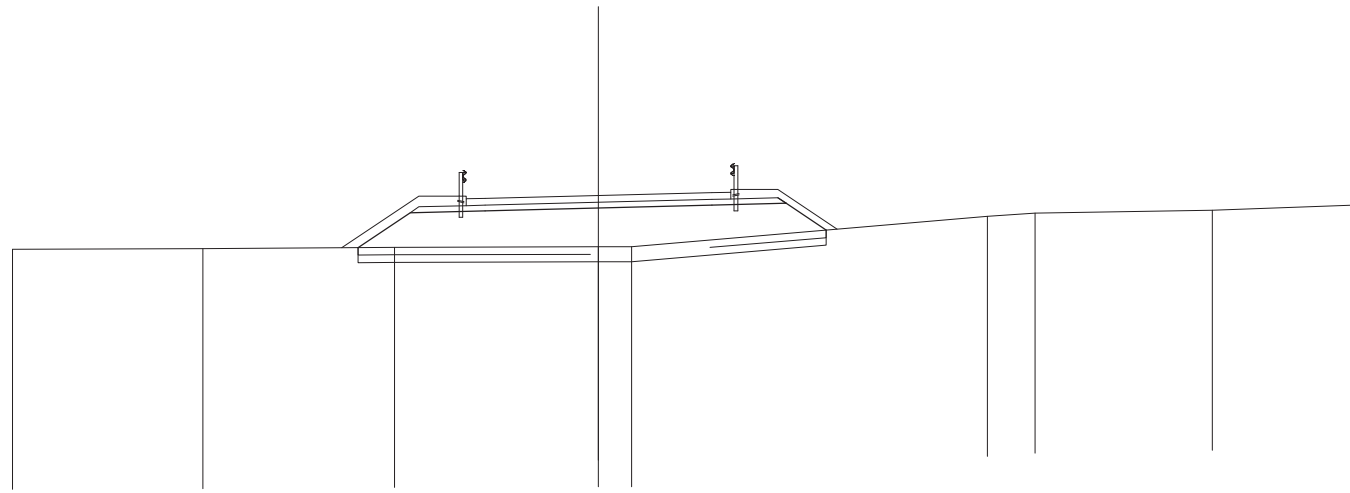

SCALA 1:200

QT. RIF. 310,000

QUOTE TERRENO		322,863		322,878		322,916		322,931		322,934		323,734		323,823		323,899		324,036
DIST. PARZIALI TERRENO			5,043		5,067		5,398		0,875		9,418		1,259		4,695		3,753	
QUOTE PROGETTO						322,909	323,831	323,880	323,955	324,030	324,224	324,075	323,372					
DIST. PARZIALI PROGETTO						1,282	1,984	3,000	3,000	1,750	1,061							
QUOTE PAVIMENTATO							324,018	324,198	324,285	324,360	324,193	324,373						
DIST. PARZIALI PAVIMENTATO							0,500	3,000	3,000	0,500								

SCAVI E BONIFICHE	
SCOTICO	13,082 m
BONIFICA	2,616 m
RILEVATI	
RILEVATO	17,867 m
TERRENO VEGETALE	7,826 m
SOVRASTRUTTURA STRADALE	
STRATI LEGATI	7,000 m
STRATO DI FONDAZIONE	1,459 m

SEZIONE N. : 98  
 QT. PROGETTO: 324,594  
 DIST. PROG. : 2159,271  
 DIST. PREC. : 20,891  
 DIST. SUCC. : 11,539

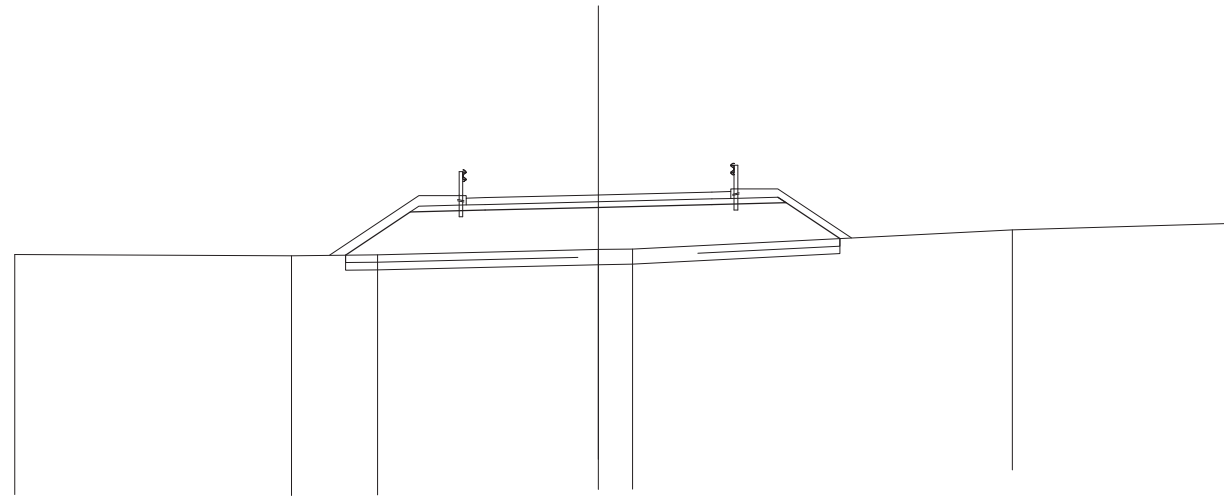

SCALA 1:200

QT. RIF. 310,000

QUOTE TERRENO	323,017	322,986	323,010	323,148	323,160	323,669	323,849
DIST. PARZIALI TERRENO	7,325	2,276	5,846	0,907	10,051	6,037	
QUOTE PROGETTO		323,001	324,139	324,264	324,339	324,532	323,438
DIST. PARZIALI PROGETTO		1,707	1,984	3,000	3,000	1,750	1,424
QUOTE PAVIMENTATO			324,506	324,594	324,669	324,501	324,681
DIST. PARZIALI PAVIMENTATO			0,500	3,000	3,000	0,500	





SCAVI E BONIFICHE	
SCOTICO	13,261 m
BONIFICA	2,652 m
RILEVATI	
RILEVATO	18,180 m
TERRENO VEGETALE	8,052 m
SOVRASTRUTTURA STRADALE	
STRATI LEGATI	7,000 m
STRATO DI FONDAZIONE	1,459 m

SEZIONE N. : 101  
 QT. PROGETTO: 325,268  
 DIST. PROG. : 2208,679  
 DIST. PREC. : 25,000  
 DIST. SUCC. : 25,413

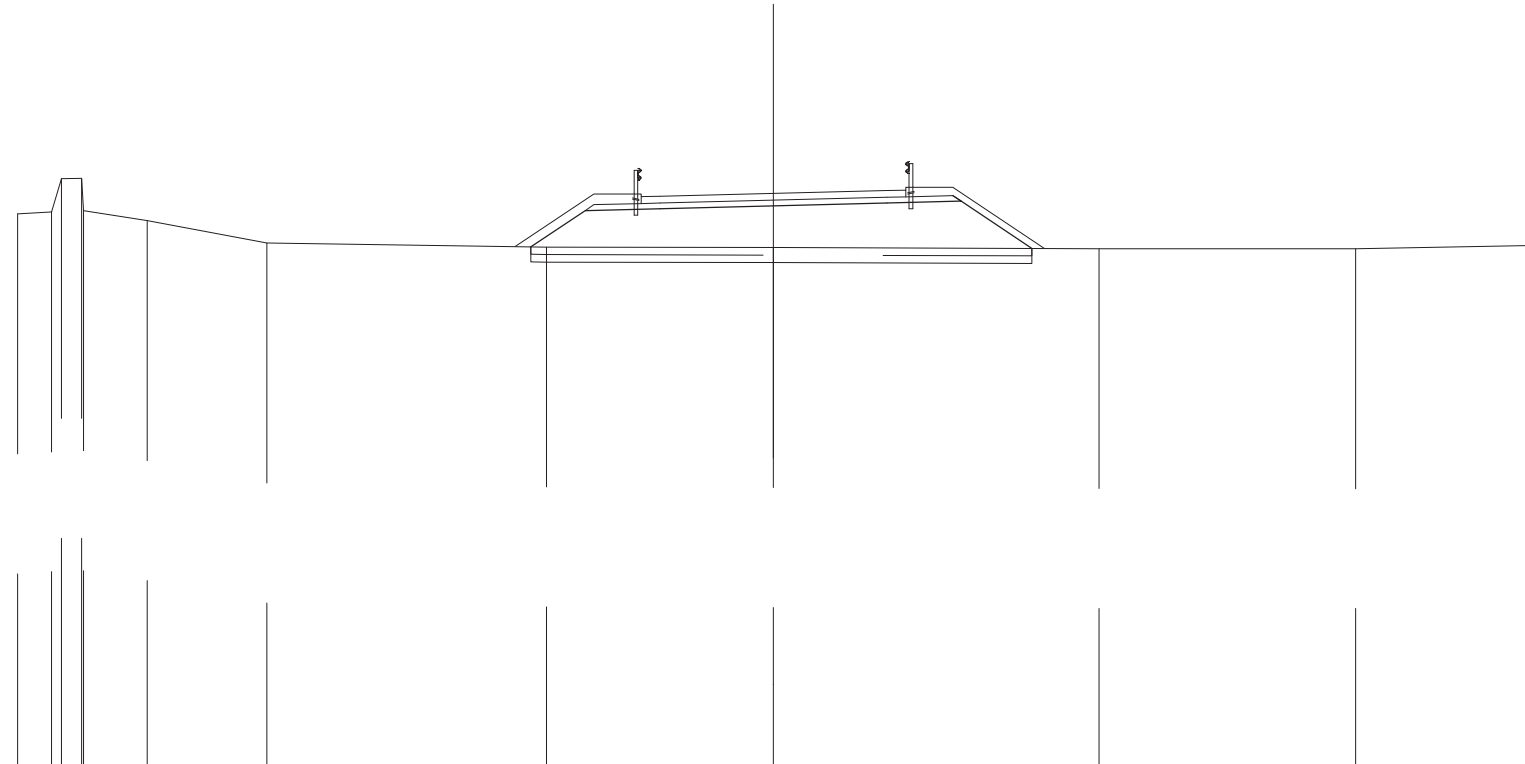

SCALA 1:200

QT. RIF. 310,000

QUOTE TERRENO	324,725	324,780	324,804	324,812	324,546	323,957	323,849	323,836	323,807	323,806	323,890		
DIST. PARZIALI TERRENO	0,890	0,529	1,686	3,167	7,398	6,008	8,615	6,795	4,590				
QUOTE PROGETTO						323,855	324,814	324,863	324,938	325,013	325,207	325,162	323,813
DIST. PARZIALI PROGETTO						1,437	1,984	3,000	3,000	1,750	1,873		
QUOTE PAVIMENTATO							325,181	325,001	325,268	325,343	325,176	325,356	
DIST. PARZIALI PAVIMENTATO							0,500	3,000	3,000	0,500			

SCAVI E BONIFICHE	
SCOTICO	12,608 m
BONIFICA	2,522 m
RILEVATI	
RILEVATO	15,436 m
TERRENO VEGETALE	7,189 m
SOVRASTRUTTURA STRADALE	
STRATI LEGATI	7,000 m
STRATO DI FONDAZIONE	1,459 m

SEZIONE N. : 102  
 QT. PROGETTO: 325,413  
 DIST. PROG. : 2234,092  
 DIST. PREC. : 25,413  
 DIST. SUCC. : 9,917

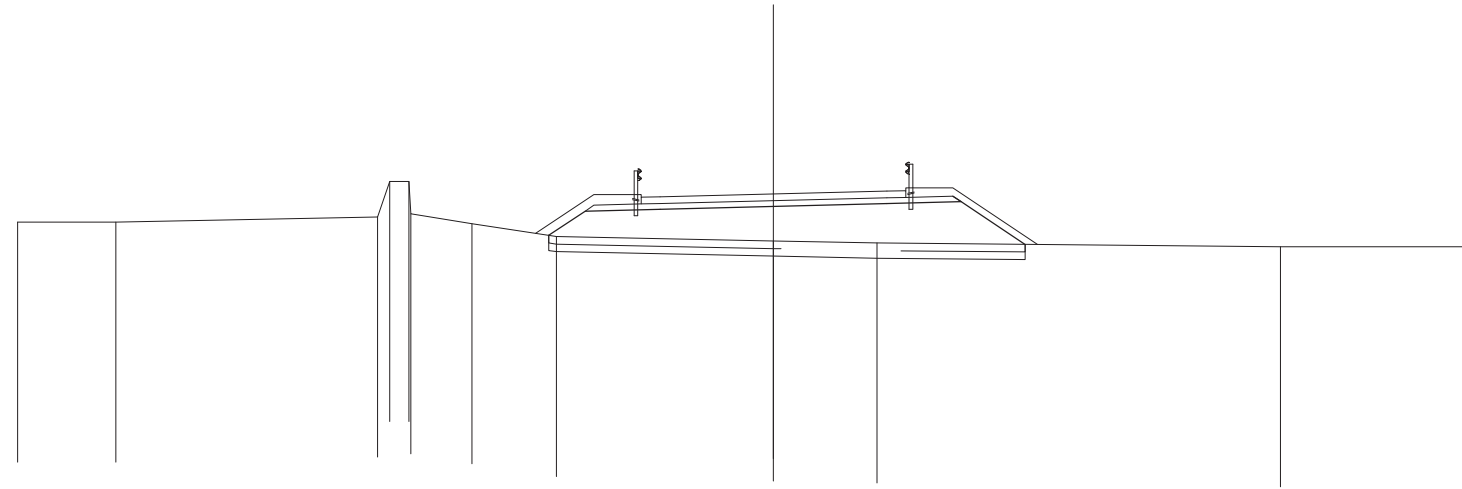

SCALA 1:200

QT. RIF. 310,000

QUOTE TERRENO		324,668	324,663	324,803	324,738	324,738	324,688	324,624	324,285	324,168	324,112	324,016	324,014
DIST. PARZIALI TERRENO		2,593	6,934	0,513	1,612	2,242	5,741	2,742	10,680	5,152			
QUOTE PROGETTO						324,316	324,958	325,008	325,083	325,158	325,352	325,207	324,077
DIST. PARZIALI PROGETTO						0,963	1,984	3,000	3,000	1,750	1,695		
QUOTE PAVIMENTATO							325,145	325,325	325,413	325,488	325,320	325,500	
DIST. PARZIALI PAVIMENTATO						0,500	3,000	3,000	0,500				

SCAVI E BONIFICHE	
SCOTICO	12,097 m
BONIFICA	2,419 m
RILEVATI	
RILEVATO	13,820 m
TERRENO VEGETALE	6,584 m
SOVRASTRUTTURA STRADALE	
STRATI LEGATI	7,000 m
STRATO DI FONDAZIONE	1,459 m

SEZIONE N. : 103  
 QT. PROGETTO: 325,448  
 DIST. PROG. : 2244,009  
 DIST. PREC. : 9,917  
 DIST. SUCC. : 9,910

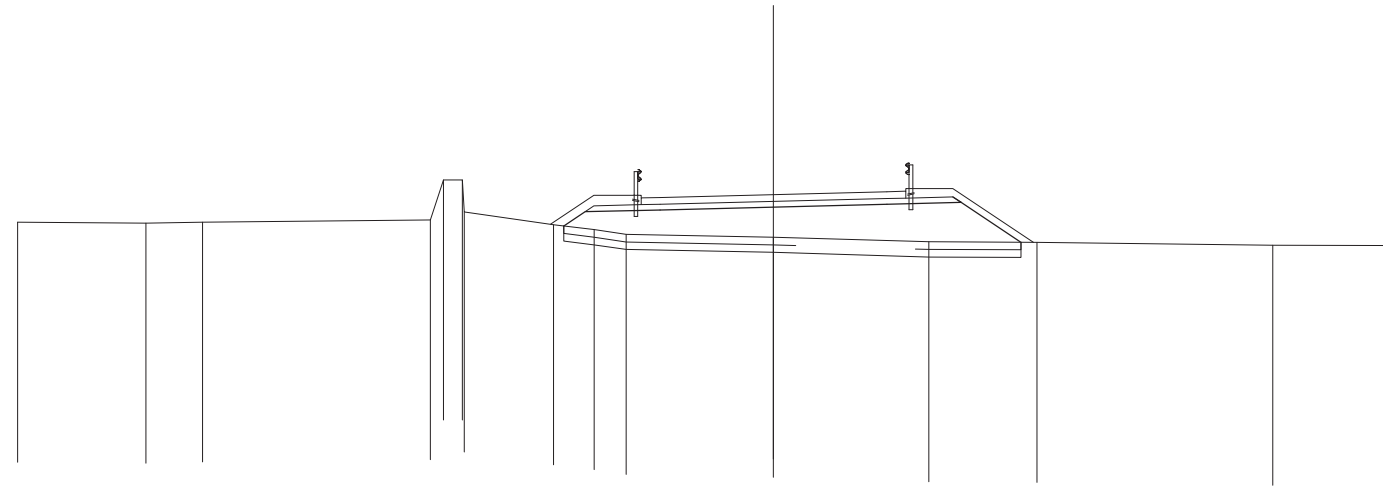

SCALA 1:200

QT. RIF. 310,000

QUOTE TERRENO	324,715	324,692	324,721	324,780	324,836	324,836	324,986	324,652	324,519	324,393	324,319	324,197	324,183	324,110	324,098
DIST. PARZIALI TERRENO	3,396	1,499	6,022	0,500	2,365	1,073	0,847	3,900	4,114	2,865	6,233	3,384			
QUOTE PROGETTO						324,618	324,993	325,043	325,118	325,193	325,387	325,242	324,185		
DIST. PARZIALI PROGETTO						0,563	1,984	3,000	3,000	1,750	1,584				
QUOTE PAVIMENTATO							325,180	325,360	325,373	325,448	325,523	325,335	325,335		
DIST. PARZIALI PAVIMENTATO							0,500	3,000	3,000	0,500					



SCAVI E BONIFICHE	
SCOTICO	12,315 m
BONIFICA	2,463 m
RILEVATI	
RILEVATO	14,087 m
TERRENO VEGETALE	6,851 m
SOVRASTRUTTURA STRADALE	
STRATI LEGATI	7,000 m
STRATO DI FONDAZIONE	1,459 m

SEZIONE N. : 104  
 QT. PROGETTO: 325,483  
 DIST. PROG. : 2253,918  
 DIST. PREC. : 9,910  
 DIST. SUCC. : 16,701

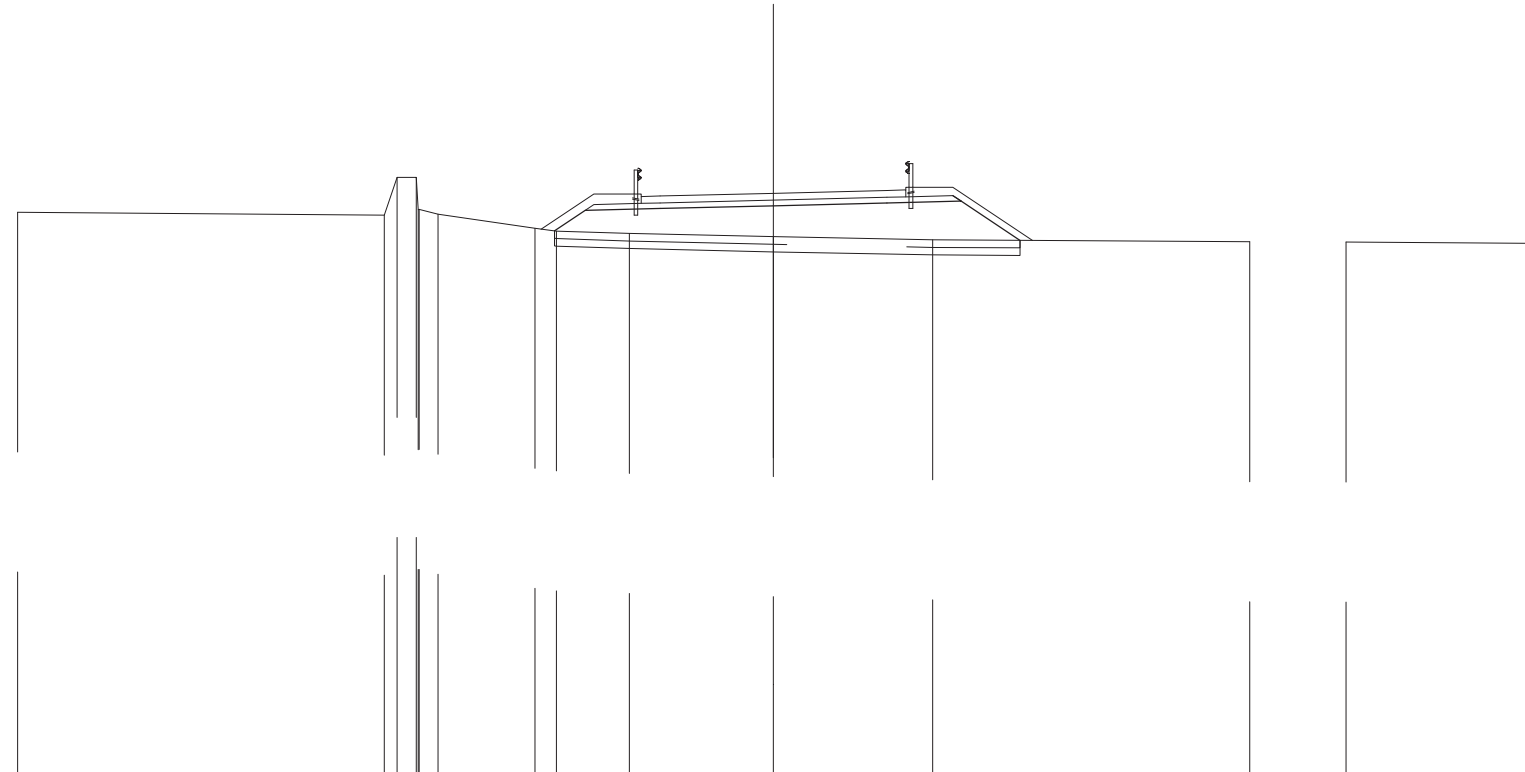

SCALA 1:200

QT. RIF. 310,000

QUOTE TERRENO	324,984	324,906	325,903	325,901	325,051	325,058	324,932	324,553	324,484	324,421	324,334	324,251	324,202	324,190	324,161
DIST. PARZIALI TERRENO	9,697	0,511	0,497	2,561	0,571	1,928	3,815	4,218	8,390	2,551	4,841				
QUOTE PROGETTO					324,490	325,028	325,078	325,153	325,228	325,422	325,277	324,238			
DIST. PARZIALI PROGETTO					0,807	1,984	3,000	3,000	1,750	1,558					
QUOTE PAVIMENTATO						325,395	325,215	325,408	325,558	325,390	325,570				
DIST. PARZIALI PAVIMENTATO						0,500	3,000	3,000	0,500						

SCAVI E BONIFICHE	
STERRO	0,489 m <sup>3</sup>
SCOTICO	6,653 m
BONIFICA	3,472 m <sup>3</sup>
RILEVATI	
RILEVATO	6,207 m <sup>3</sup>
TERRENO VEGETALE	5,076 m
SOVRASTRUTTURA STRADALE	
STRATI LEGATI	7,803 m
STRATO DI FONDAZIONE	1,375 m <sup>3</sup>

SEZIONE N. : 105  
 QT. PROGETTO: 325,542  
 DIST. PROG. : 2270,619  
 DIST. PREC. : 16,701  
 DIST. SUCC. : 6,793

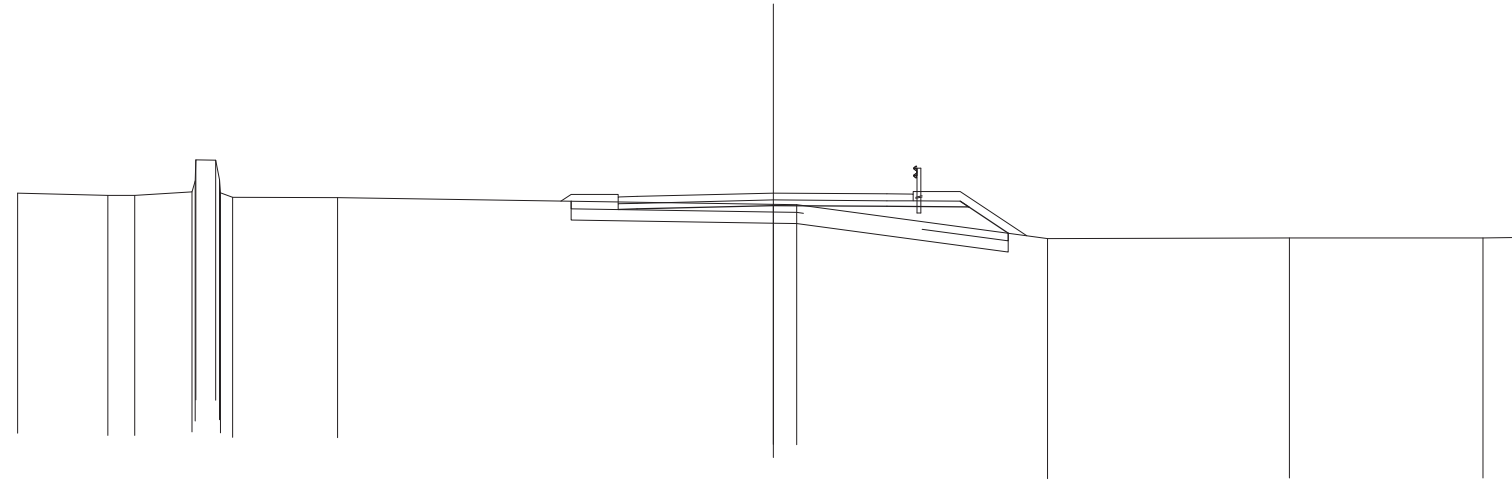

SCALA 1:200

QT. RIF. 310,000

QUOTE TERRENO	325,535	325,480	325,481	325,575	325,857	325,418	325,800	325,545	325,425	325,422	325,243	325,232	324,337	324,355	324,351	324,369
DIST. PARZIALI TERRENO	2,385	0,708	1,522	0,528	2,777	11,533	0,613	6,639	6,400	5,125	1,223					
QUOTE PROGETTO							325,109	325,121	325,212	325,189	325,324	325,173	324,477			
DIST. PARZIALI PROGETTO							0,500	3,608	3,000	1,945	1,043					
QUOTE PAVIMENTATO							325,259	325,431	325,542	325,519	325,334	325,514				
DIST. PARZIALI PAVIMENTATO							0,500	3,608	3,000	0,695						

SCAVI E BONIFICHE	
STERRO	3,753 m <sup>3</sup>
BONIFICA	0,861 m <sup>3</sup>
RILEVATI	
RILEVATO	0,861 m <sup>3</sup>
TERRENO VEGETALE	0,900 m
SOVRASTRUTTURA STRADALE	
STRATI LEGATI	7,000 m
STRATO DI FONDAZIONE	1,050 m <sup>3</sup>

SEZIONE N. : 106  
 QT. PROGETTO: 325,566  
 DIST. PRG. : 2277,412  
 DIST. PREC. : 6,793

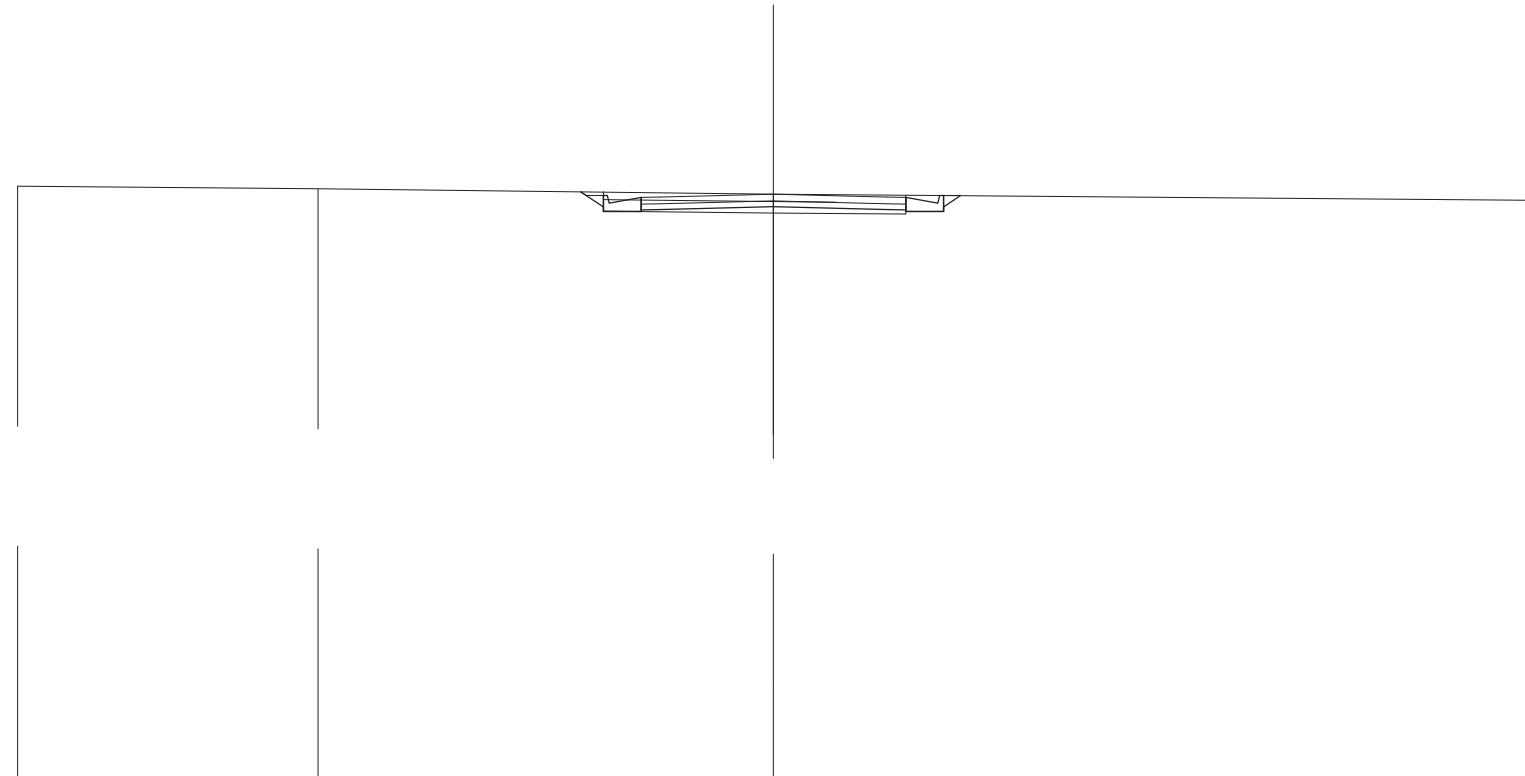

SCALA 1:200

QT. RIF. 310,000

QUOTE TERRENO	325,773	325,710	325,566	325,402
DIST. PARZIALI TERRENO	7,950	12,050	20,000	
QUOTE PROGETTO			325,236	
DIST. PARZIALI PROGETTO			3,000	
QUOTE PAVIMENTATO			325,566	
DIST. PARZIALI PAVIMENTATO			3,000	