

S.S.131 DI "CARLO FELICE"
Adeguamento e messa in sicurezza della S.S.131
Risoluzione dei nodi critici 2° stralcio
dal km 108+300 al km 158+000

PROGETTO ESECUTIVO

CA284

R.T.I. di PROGETTAZIONE:

Mandataria



**PRO
ITER**
Progetto
Infrastrutture
Territorio s.r.l.

Via G.B. Sammartini n°5
20125 - Milano
Tel. 02 6787911
email: mail@proiter.it

Mandante



Via Artemide n°3
92100 Agrigento
Tel. 0922 421007
email: deltaingegneria@pec.it

PROGETTISTI:

Ing. Riccardo Formichi - Pro Iter srl (Integratore prestazioni specialistiche)
Ordine Ing. di Milano n. 18045

Ing. Nicola D'Alessandro - Delta Ingegneria srl
Ordine Ing. di Agrigento n. A995

IL GEOLOGO

Dott. Geol. Massimo Mezzanatica - Pro Iter srl
Albo Geol. Lombardia n. A762

COORDINATORE PER LA SICUREZZA IN FASE DI PROGETTAZIONE

Ing. Diego Ceccherelli
Ordine Ing. di Milano n. 15813

VISTO: IL RESP. DEL PROCEDIMENTO

Dott. Ing. Salvatore Frasca

PROTOCOLLO

DATA



PROGETTO STRADALE
Risoluzione accesso C. S. al Km 139+930
Sezioni trasversali

CODICE PROGETTO

PROGETTO LIV. PROG. N. PROG.

LOPLSQ E 1901

NOME FILE

S09PS00TRASZ01_C

CODICE
ELAB.

S09PS00TRASZ01

REVISIONE

SCALA

C

varie

REV.	DESCRIZIONE	DATA	REDATTO	VERIFICATO	APPROVATO
D					
C	REVISIONE PER ISTRUTTORIA, VERIFICA E CONTROLLI D.LGS. 35/11	Agosto 2020	Ing.D. D'ALESSANDRO	Ing. M. CARLINO	Ing.N. D'ALESSANDRO
B	Emissione	Marzo 2020	Ing.D. D'ALESSANDRO	Ing. M. CARLINO	Ing.N. D'ALESSANDRO
A	Emissione per controlli D.LGS. 35/2011	Novembre 2019	Ing.D. D'ALESSANDRO	Ing. M. CARLINO	Ing.N. D'ALESSANDRO

SCAVI E BONIFICHE	
SCOTICO	12,310 m
BONIFICA	4,924 m ²
RILEVATI	
RILEVATO	18,764 m ²
TERRENO VEGETALE	6,432 m
SOVRASTRUTTURA STRADALE	
STRATI LEGATI	7,000 m
STRATO DI FONDAZIONE	1,459 m ²

SEZIONE N.: 7
 QT. PROGETTO: 438,636
 DIST.PROG.: 70,381
 DIST.PREC.: 8,857
 DIST.SUCC.: 9,619

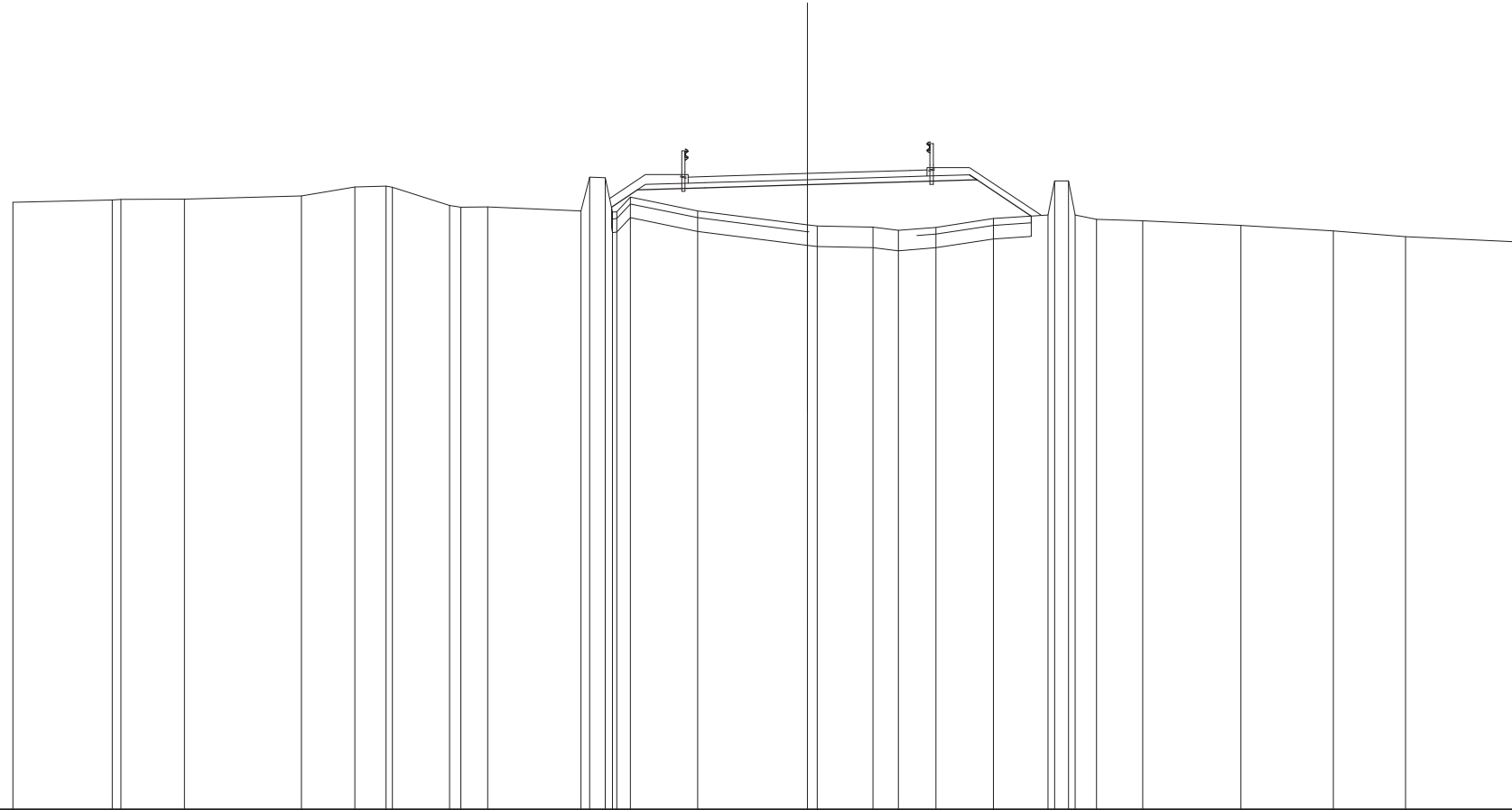

SCALA 1:200

QT.RIF. 420,000

QUOTE TERRENO	437,788	437,855 437,877	437,880	437,976	438,243	438,263 438,286	437,685 437,648	437,658	437,536 438,525 438,510 437,504 437,516 437,941	437,539	437,130 437,084	437,059 436,972	437,058	437,316	437,420 438,420 438,419 437,419 437,292	437,247	437,117	436,953	436,784	436,626	
DIST.PARZIALI TERRENO	2,909	1,866	3,426	1,569	0,918	1,877	0,781	2,731	0,455 0,406	1,971	3,218	1,640	0,741 1,103	1,680	1,599	0,402 0,622	1,355	2,876	2,716	2,118	3,439
QUOTE PROGETTO									437,648 438,156	438,216	438,306	438,386	438,598 438,455	437,389							
DIST.PARZIALI PROGETTO									0,761	1,985	3,000	3,000	1,750	1,598							
QUOTE PAVIMENTATO										438,351 438,531 438,546	438,636	438,726 438,591 438,741									
DIST.PARZIALI PAVIMENTATO										0,500	3,000	3,000	0,500								

SCAVI E BONIFICHE	
STERRO	0,506 m ²
SCOTICO	10,052 m
BONIFICA	4,883 m ²
RILEVATI	
RILEVATO	12,760 m ²
TERRENO VEGETALE	6,704 m
SOVRASTRUTTURA STRADALE	
STRATI LEGATI	7,000 m
STRATO DI FONDAZIONE	1,459 m ²

SEZIONE N.: 10
 QT. PROGETTO: 442,452
 DIST.PROG.: 111,586
 DIST.PREC.: 11,586
 DIST.SUCC.: 8,414

SCALA 1:200

QT.RIF. 430,000

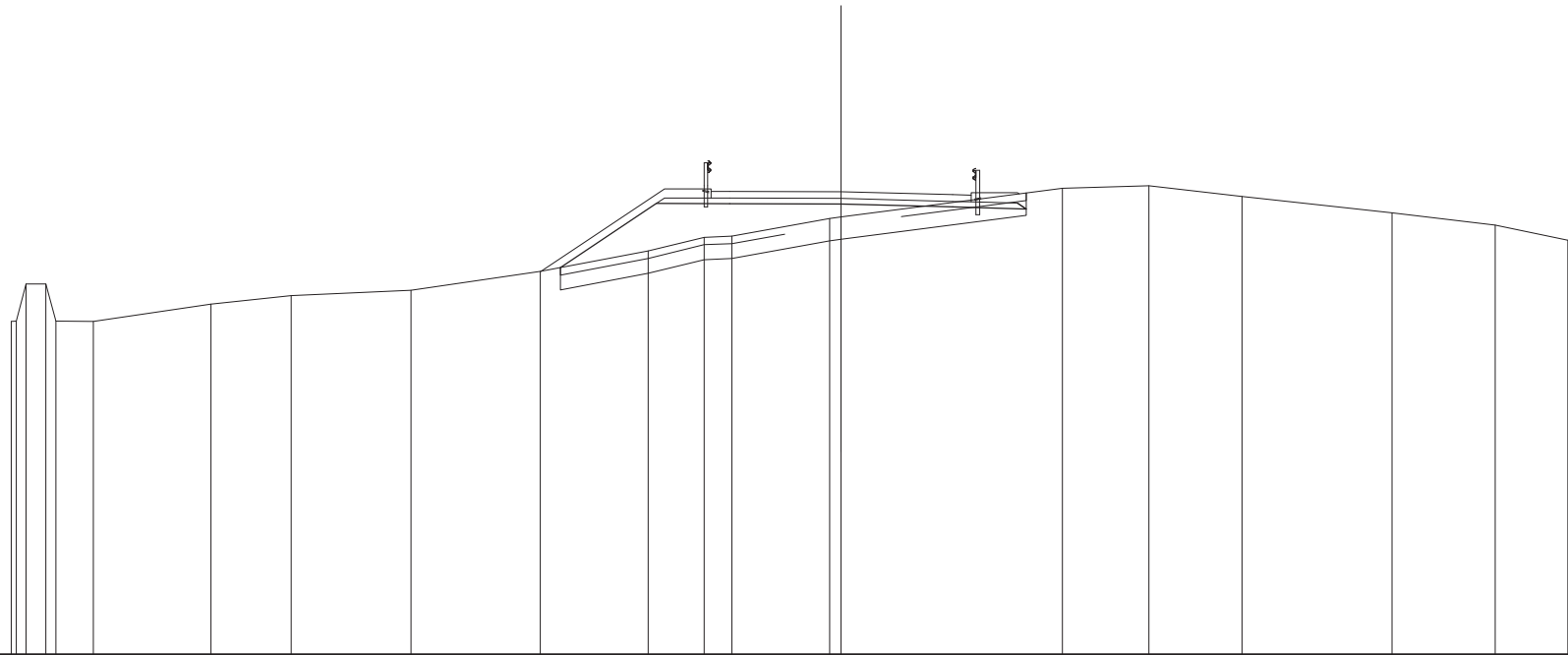

QUOTE TERRENO	438,958 438,968 438,970 438,971 438,980	438,422	438,656	438,788	440,305	440,856	441,223 441,253	441,727 441,767	442,541	442,605	442,317	441,880	441,548	441,141
DIST.PARZIALI TERRENO	0,636 1,008	3,167	2,160	3,224	3,480	2,907	1,506 0,743	2,636	5,962	2,326	2,506	4,041	2,780	1,954
QUOTE PROGETTO					440,407	442,131	442,127	442,122	442,039	442,141 441,965				
DIST.PARZIALI PROGETTO						2,585	1,974	3,000	3,000	1,750				
QUOTE PAVIMENTATO							442,278 442,458 442,457	442,452	442,369 442,176 442,356					
DIST.PARZIALI PAVIMENTATO							0,500	3,000	3,000	0,500				

SCAVI E BONIFICHE	
SCOTICO	11,822 m
BONIFICA	4,729 m ²
RILEVATI	
RILEVATO	12,572 m ²
TERRENO VEGETALE	6,383 m
SOVRASTRUTTURA STRADALE	
STRATI LEGATI	7,000 m
STRATO DI FONDAZIONE	1,459 m ²

SEZIONE N.: 11
 QT. PROGETTO: 443,171
 DIST.PROG.: 120,000
 DIST.PREC.: 8,414
 DIST.SUCC.: 20,000

SCALA 1:200

QT.RIF. 430,000

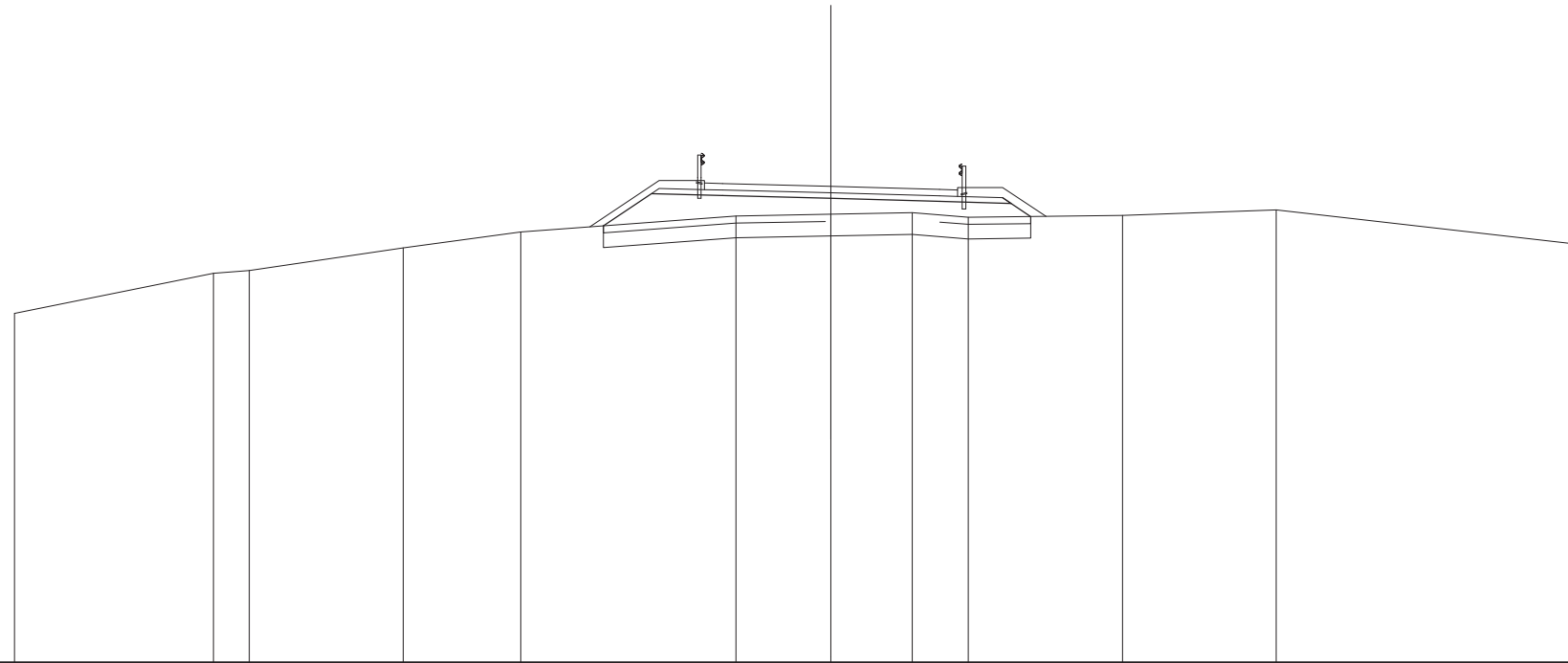

QUOTE TERRENO	439,662	440,761	440,842	441,486	441,909	442,349	442,396	442,436	442,315	442,361	442,518	441,567
DIST.PARZIALI TERRENO	5,499	0,984	4,255	3,253	5,953	2,628	2,250	1,550	4,268	4,254	8,174	
QUOTE PROGETTO						442,078	442,965	442,916	442,841	442,752	442,850	442,683
DIST.PARZIALI PROGETTO						1,330	1,967	3,000	3,000	1,750	0,540	
QUOTE PAVIMENTATO							443,078	443,258	443,246	443,171	443,082	442,987
DIST.PARZIALI PAVIMENTATO							0,500	3,000	3,000	0,500		

SCAVI E BONIFICHE	
SCOTICO	11,737 m
BONIFICA	4,695 m ²
RILEVATI	
RILEVATO	10,699 m ²
TERRENO VEGETALE	6,384 m
SOVRASTRUTTURA STRADALE	
STRATI LEGATI	7,000 m
STRATO DI FONDAZIONE	1,459 m ²

SEZIONE N.: 12
 QT. PROGETTO: 444,176
 DIST.PROG.: 140,000
 DIST.PREC.: 20,000
 DIST.SUCC.: 5,316

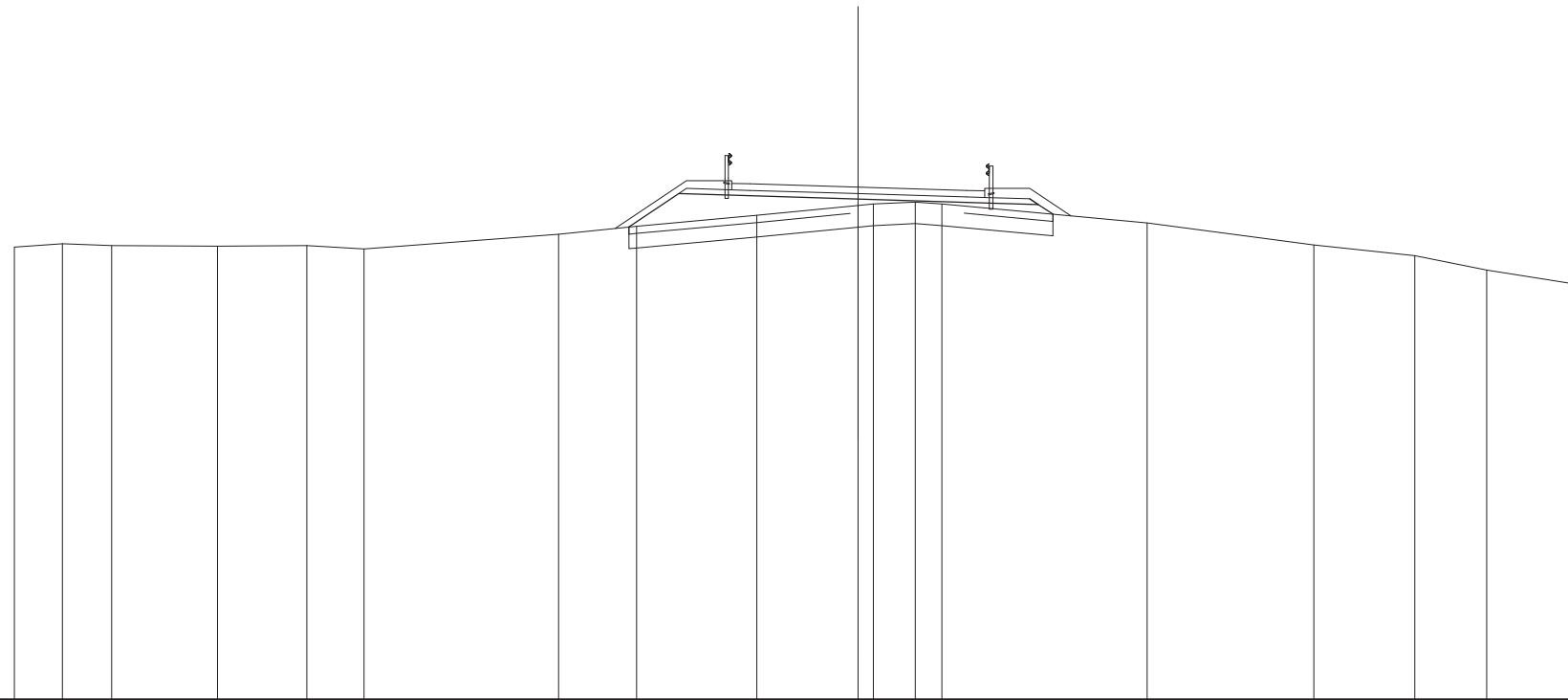

SCALA 1:200

QT.RIF. 430,000

QUOTE TERRENO	442,514	442,607	442,554	442,537	442,560	442,469	442,870	443,094	443,384	443,688	443,709	443,764	443,710	443,187	442,579	442,281	441,884	441,482
DIST.PARZIALI TERRENO	1,331	1,366	2,927	2,472	1,587	5,388	2,156	3,332	2,802	0,423	1,180	0,738	5,675	4,622	2,791	1,991	2,510	
QUOTE PROGETTO								443,072	443,995	443,936	443,846		443,756					
DIST.PARZIALI PROGETTO								1,383	1,965	3,000	3,000	1,750	0,403					
QUOTE PAVIMENTATO									444,101	444,281	444,266	444,176	444,086	443,891	444,071			
DIST.PARZIALI PAVIMENTATO									0,500	3,000	3,000	0,500						

SCAVI E BONIFICHE	
SCOTICO	11,572 m
BONIFICA	4,629 m ²
RILEVATI	
RILEVATO	10,733 m ²
TERRENO VEGETALE	6,156 m
SOVRASTRUTTURA STRADALE	
STRATI LEGATI	7,000 m
STRATO DI FONDAZIONE	1,459 m ²

SEZIONE N.: 13
 QT. PROGETTO: 444,274
 DIST.PROG.: 145,316
 DIST.PREC.: 5,316
 DIST.SUCC.: 14,684

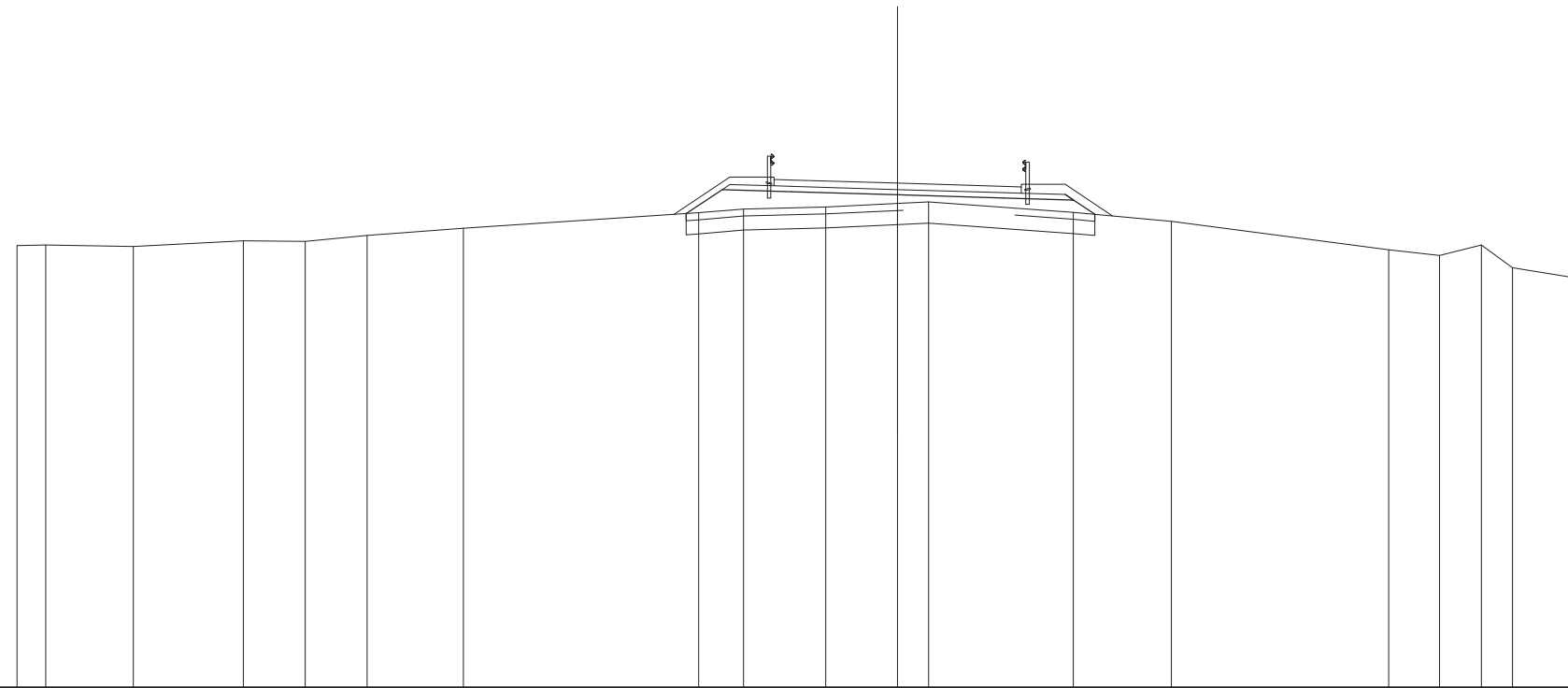

SCALA 1:200

QT.RIF. 430,000

QUOTE TERRENO	442,511	442,521	442,485	442,640	442,627	442,789	442,989	443,436	443,544	443,603	443,700	443,742	443,449	443,194	442,389	442,229	442,525	441,881	441,571
DIST.PARZIALI TERRENO	0,886	2,483	3,120	1,749	1,759	2,722	6,666	1,272	2,325	2,036	0,878	4,100	2,778	6,154	1,438	1,185	0,886	1,938	
QUOTE PROGETTO								443,413	444,093	444,034	443,944		443,854	443,952	443,795	443,384			
DIST.PARZIALI PROGETTO								1,020	1,965	3,000	3,000	1,750	0,802						
QUOTE PAVIMENTATO									444,189	444,379	444,364	444,274	444,184	443,989	444,189				
DIST.PARZIALI PAVIMENTATO									0,500	3,000	3,000	0,500							

SCAVI E BONIFICHE	
STERRO	0,334 m ²
SCOTICO	7,681 m
BONIFICA	4,353 m ²
RILEVATI	
RILEVATO	8,059 m ²
TERRENO VEGETALE	5,005 m
SOVRASTRUTTURA STRADALE	
STRATI LEGATI	7,000 m
STRATO DI FONDAZIONE	1,460 m ²

SEZIONE N.: 15
 QT. PROGETTO: 444,545
 DIST.PROG.: 172,713
 DIST.PREC.: 12,713
 DIST.SUCC.: 7,287

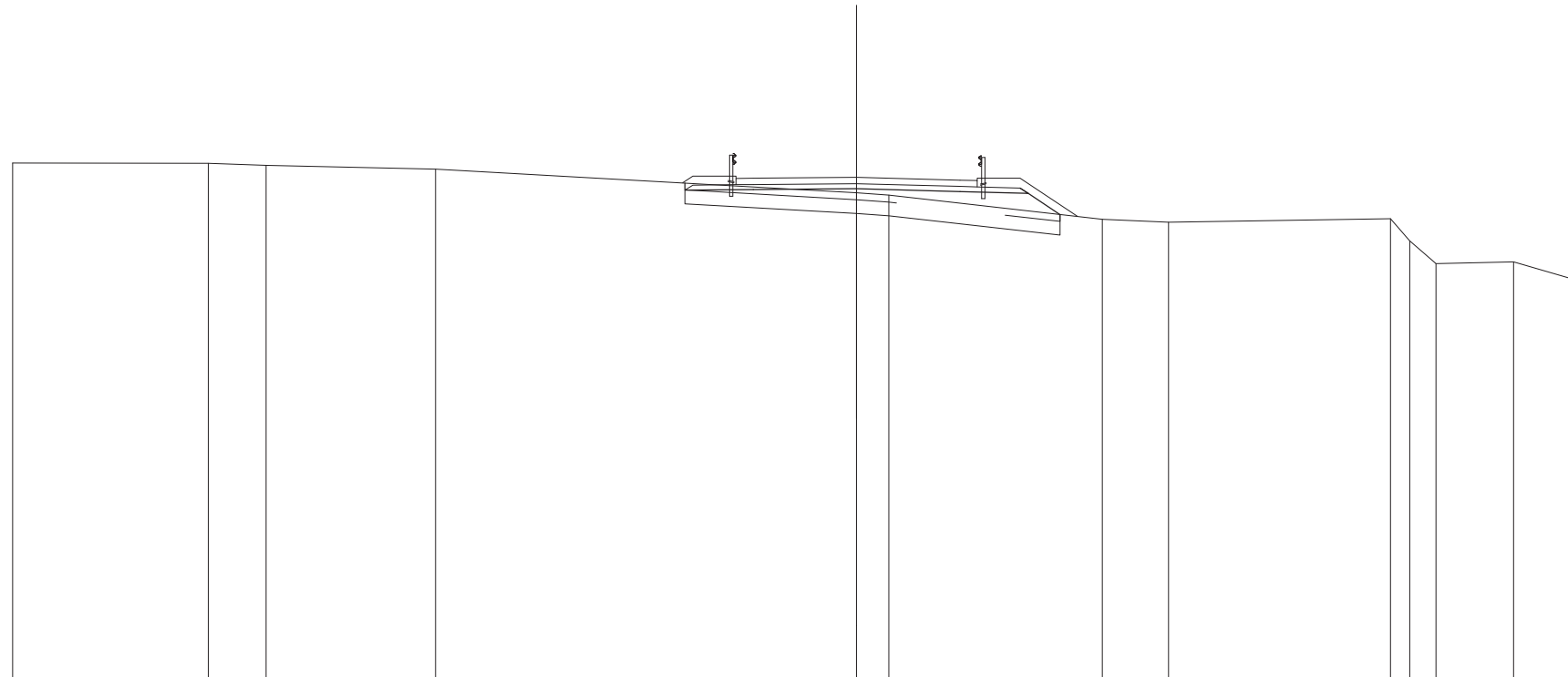

SCALA 1:200

QT.RIF. 430,000

QUOTE TERRENO	444,963	444,961	444,893	444,788	444,099	444,028	443,328	443,244	443,343	442,706	442,045	442,092	441,530
DIST.PARZIALI TERRENO	5,681	1,677	4,919	12,223	0,941	6,197	1,917	6,446	0,681	0,763	2,250	1,921	
QUOTE PROGETTO					444,171	444,189	444,215	444,135	444,239	444,083	443,488		
DIST.PARZIALI PROGETTO					1,978	3,000	3,000	1,750	0,622				
QUOTE PAVIMENTATO					444,334	444,514	444,519	444,545	444,465	444,772	444,452		
DIST.PARZIALI PAVIMENTATO					0,500	3,000	3,000	0,500					

SCAVI E BONIFICHE	
STERRO	0,205 m ²
SCOTICO	8,252 m
BONIFICA	4,112 m ²
RILEVATI	
RILEVATO	6,811 m ²
TERRENO VEGETALE	4,293 m
SOVRASTRUTTURA STRADALE	
STRATI LEGATI	7,000 m
STRATO DI FONDAZIONE	1,255 m ²

SEZIONE N.: 16
 QT. PROGETTO: 444,616
 DIST.PROG.: 180,000
 DIST.PREC.: 7,287
 DIST.SUCC.: 20,000

SCALA 1:200

QT.RIF. 430,000

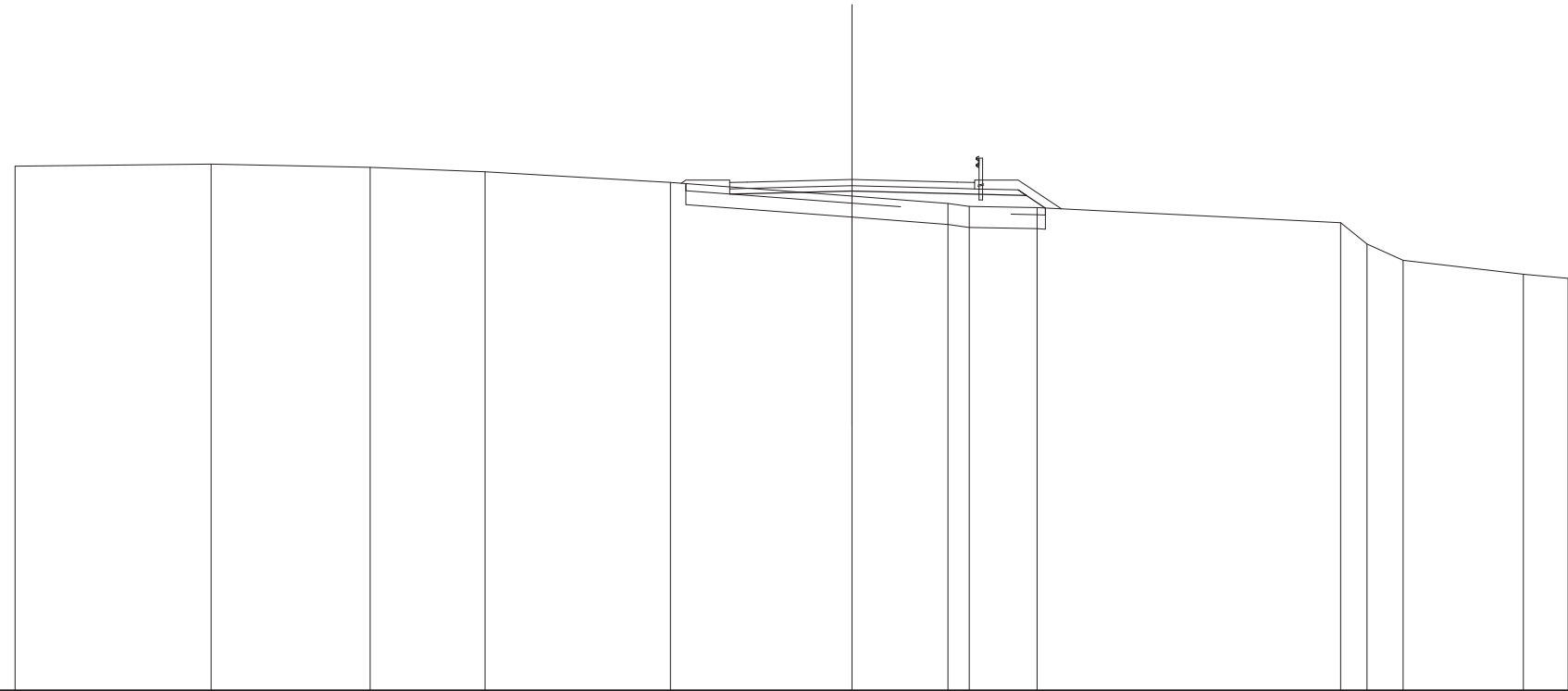

QUOTE TERRENO	445,000	445,059	444,961	444,835	444,528	444,139	443,931	443,848	443,809	443,379	442,769	442,300	441,903	441,790	441,740
DIST.PARZIALI TERRENO	5,808	4,544	3,281	5,302	5,196	2,743	0,807	1,941	8,675	0,761	1,027	3,438	1,279	0,389	
QUOTE PROGETTO						444,199	444,211	444,286	444,211	444,317	444,162	443,797			
DIST.PARZIALI PROGETTO						0,500	3,000	3,000	1,750	0,546					
QUOTE PAVIMENTATO						444,349	444,529	444,541	444,616	444,541	444,349	444,529			
DIST.PARZIALI PAVIMENTATO						0,500	3,000	3,000	0,500						

SCAVI E BONIFICHE	
STERRO	0,111 m ²
SCOTICO	8,672 m
BONIFICA	4,161 m ²
RILEVATI	
RILEVATO	7,864 m ²
TERRENO VEGETALE	4,518 m
SOVRASTRUTTURA STRADALE	
STRATI LEGATI	7,000 m
STRATO DI FONDAZIONE	1,460 m ²

SEZIONE N.: 17
 QT. PROGETTO: 444,813
 DIST.PROG.: 200,000
 DIST.PREC.: 20,000
 DIST.SUCC.: 20,000

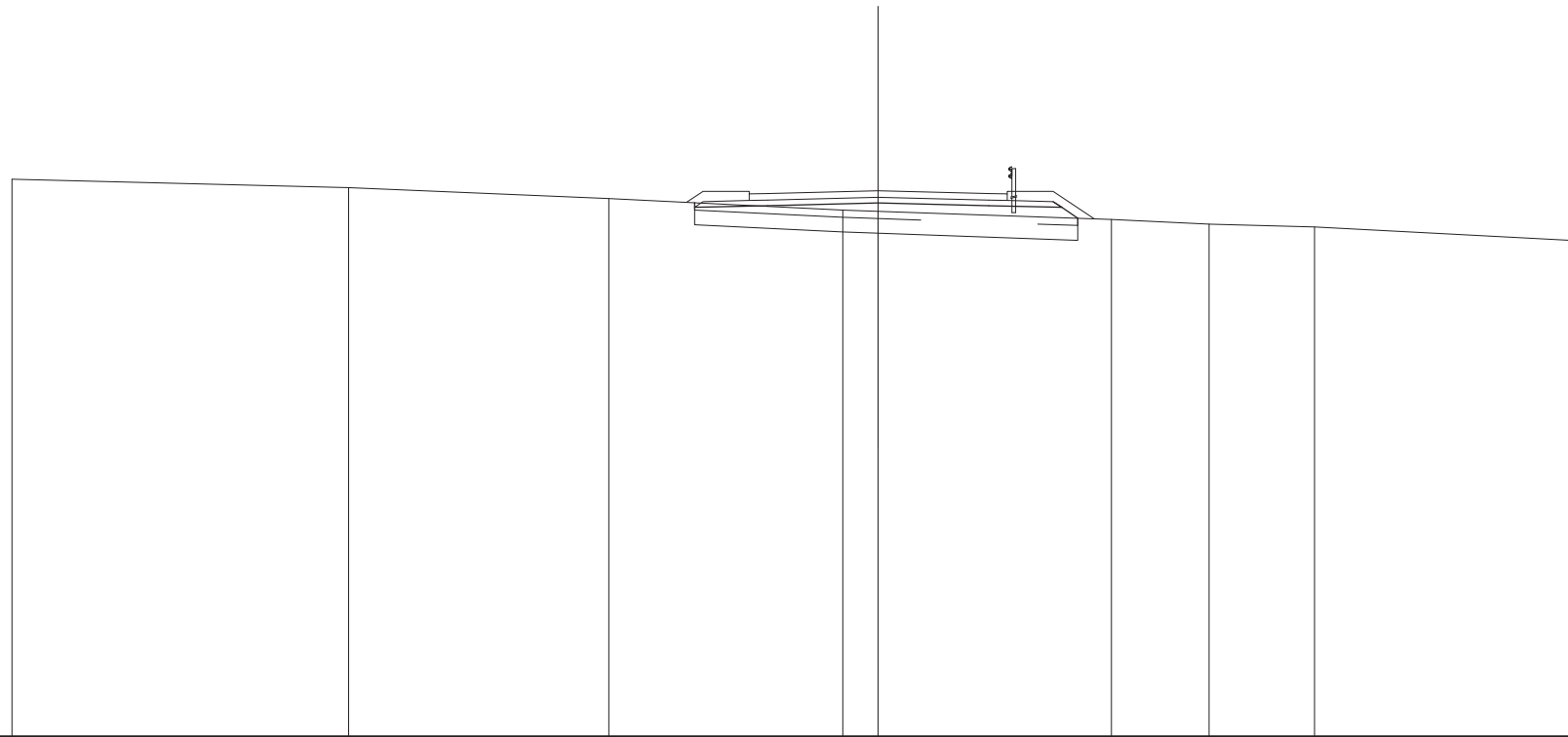

SCALA 1:200

QT.RIF. 430,000

QUOTE TERRENO	445,125	444,899	444,600	444,289	444,256	444,036	443,901	443,825	443,468	
DIST.PARZIALI TERRENO		9,135	7,059	6,357	0,957	6,334	2,651	2,860	6,953	
QUOTE PROGETTO				444,358	444,408	444,483	444,408	444,514	444,358	444,067
DIST.PARZIALI PROGETTO				1,984	3,000	3,000	1,750	0,638		
QUOTE PAVIMENTATO				444,545	444,725	444,738	444,813	444,738	444,545	444,725
DIST.PARZIALI PAVIMENTATO				0,600	3,000	3,000	0,600			

SCAVI E BONIFICHE	
SCOTICO	10,594 m
BONIFICA	4,238 m ²
RILEVATI	
RILEVATO	10,371 m ²
TERRENO VEGETALE	4,890 m
SOVRASTRUTTURA STRADALE	
STRATI LEGATI	7,000 m
STRATO DI FONDAZIONE	1,460 m ²

SEZIONE N.: 18
 QT. PROGETTO: 445,009
 DIST.PROG.: 220,000
 DIST.PREC.: 20,000
 DIST.SUCC.: 20,000

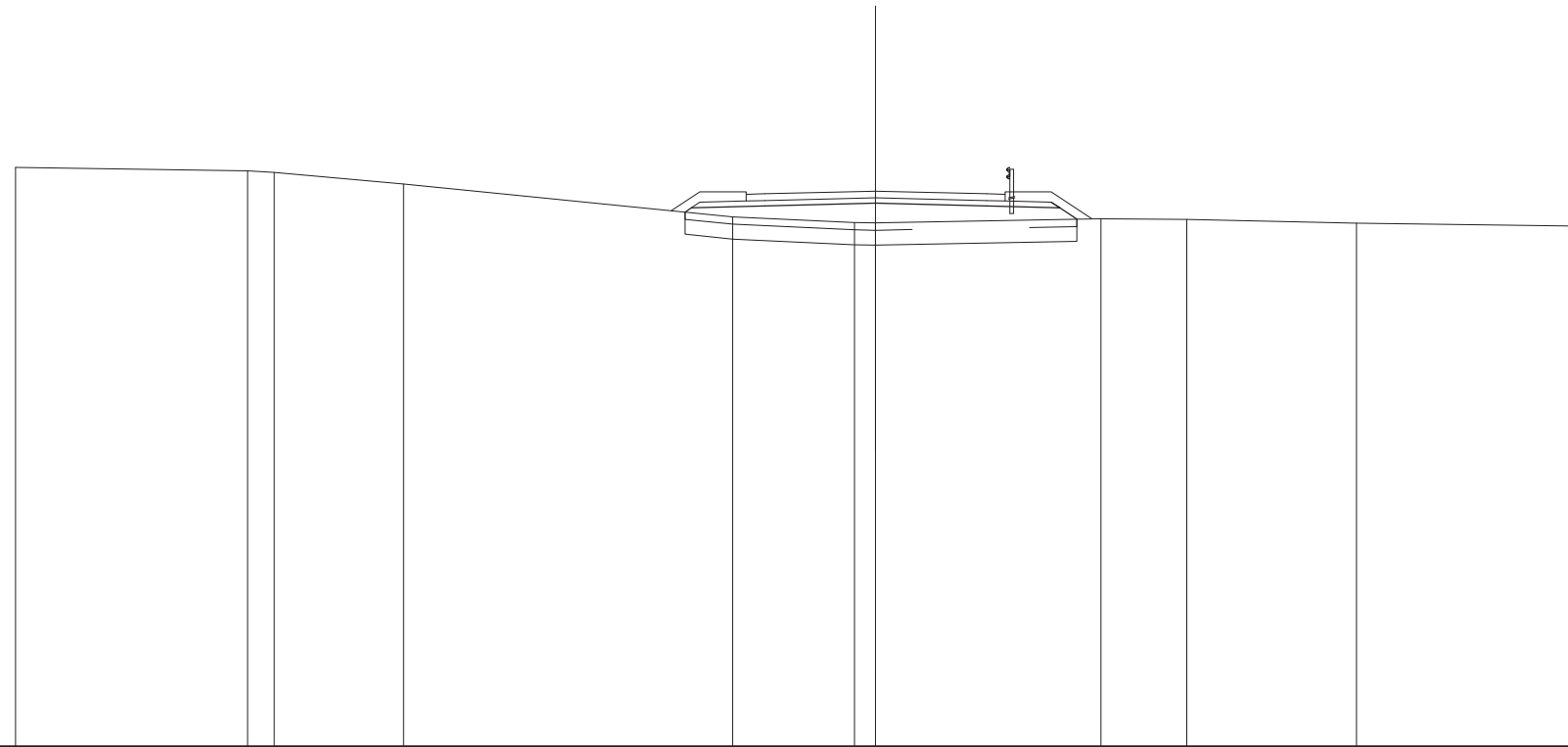

SCALA 1:200

QT.RIF. 430,000

QUOTE TERRENO	445,647	445,556 445,513	445,204	444,313	444,180 444,150	444,262	444,241	444,141	444,066
DIST.PARZIALI TERRENO	6,278	0,718 3,494	8,900	3,294	0,672 6,093	2,320	4,592	5,803	
QUOTE PROGETTO				444,442 444,555	444,604	444,679	444,604	444,711 444,555 444,250	
DIST.PARZIALI PROGETTO				1,984	3,000	3,000	1,750	0,467	
QUOTE PAVIMENTATO				444,742 444,922 444,894	445,009	444,934 444,742 444,922			
DIST.PARZIALI PAVIMENTATO				0,600	3,000	3,000	0,600		

SCAVI E BONIFICHE	
SCOTICO	13,015 m
BONIFICA	5,206 m ²
RILEVATI	
RILEVATO	18,086 m ²
TERRENO VEGETALE	7,738 m
SOVRASTRUTTURA STRADALE	
STRATI LEGATI	7,000 m
STRATO DI FONDAZIONE	1,459 m ²

SEZIONE N.: 23
 QT. PROGETTO: 443,675
 DIST.PROG.: 313,988
 DIST.PREC.: 13,988
 DIST.SUCC.: 6,012

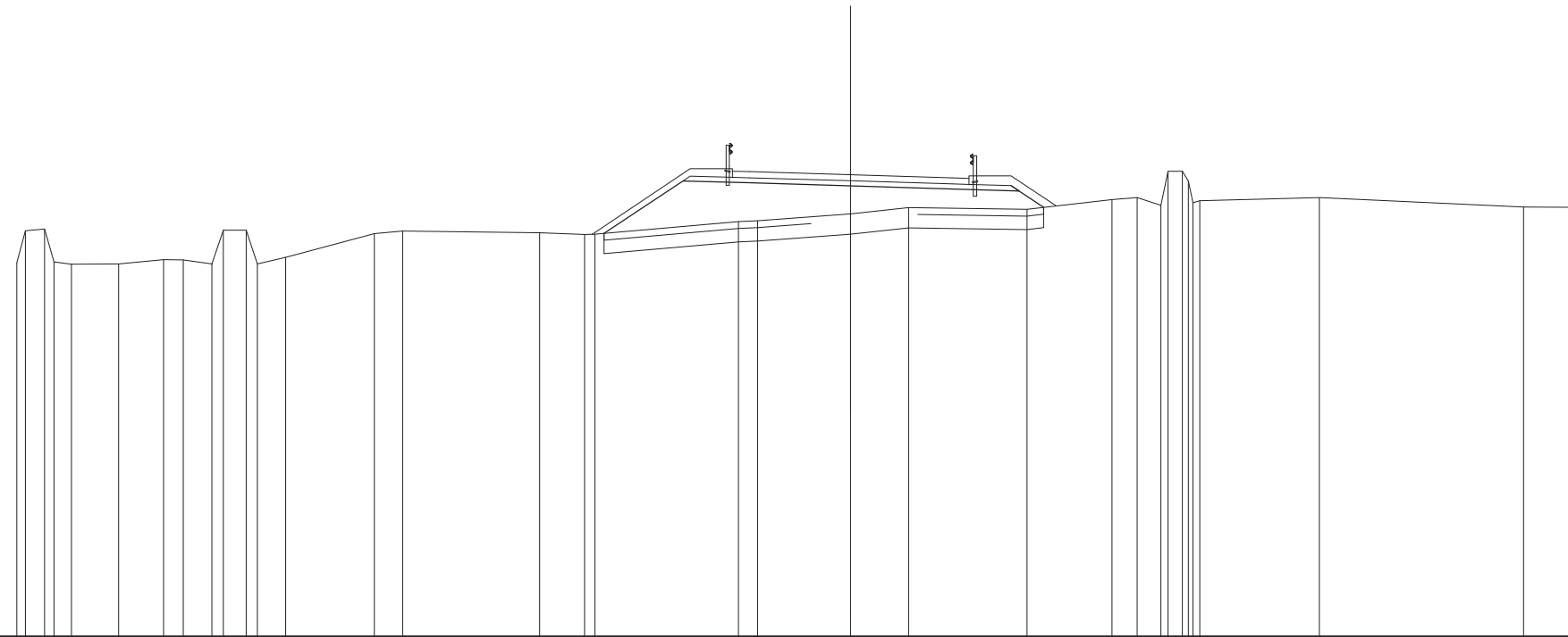

SCALA 1:200

QT.RIF. 430,000

QUOTE TERRENO	441,071 442,012 442,063 441,090 441,023	441,031	441,162 441,151 441,037 442,036 442,033 441,032 441,231	441,929 442,005	441,957	441,902 441,913	442,283 442,312	442,517	442,702	442,651	442,941 442,985 442,772 443,775 443,780 443,489 442,860 442,907	442,984	442,720	442,710		
DIST.PARZIALI TERRENO	0,588 0,517	1,398	1,333 0,577 0,851 0,674 0,639	2,623	0,639	4,054	1,328	4,253	0,590 2,758	1,713	3,512	2,512	0,748 0,701 0,434	3,544	6,049	1,499
QUOTE PROGETTO						441,937	443,494	443,435	443,345	443,255	443,352 443,195 442,708					
DIST.PARZIALI PROGETTO						2,334	1,965	3,000	3,000	1,750	0,790					
QUOTE PAVIMENTATO							443,600 443,780 443,765	443,675	443,585 443,390 443,570							
DIST.PARZIALI PAVIMENTATO							0,500	3,000	3,000	0,500						

SCAVI E BONIFICHE	
SCOTICO	12,393 m
BONIFICA	4,957 m ²
RILEVATI	
RILEVATO	19,650 m ²
TERRENO VEGETALE	7,218 m
SOVRASTRUTTURA STRADALE	
STRATI LEGATI	7,000 m
STRATO DI FONDAZIONE	1,460 m ²

SEZIONE N.: 36
 QT. PROGETTO: 434,941
 DIST.PROG.: 460,000
 DIST.PREC.: 20,000
 DIST.SUCC.: 20,000

SCALA 1:200

QT.RIF. 420,000

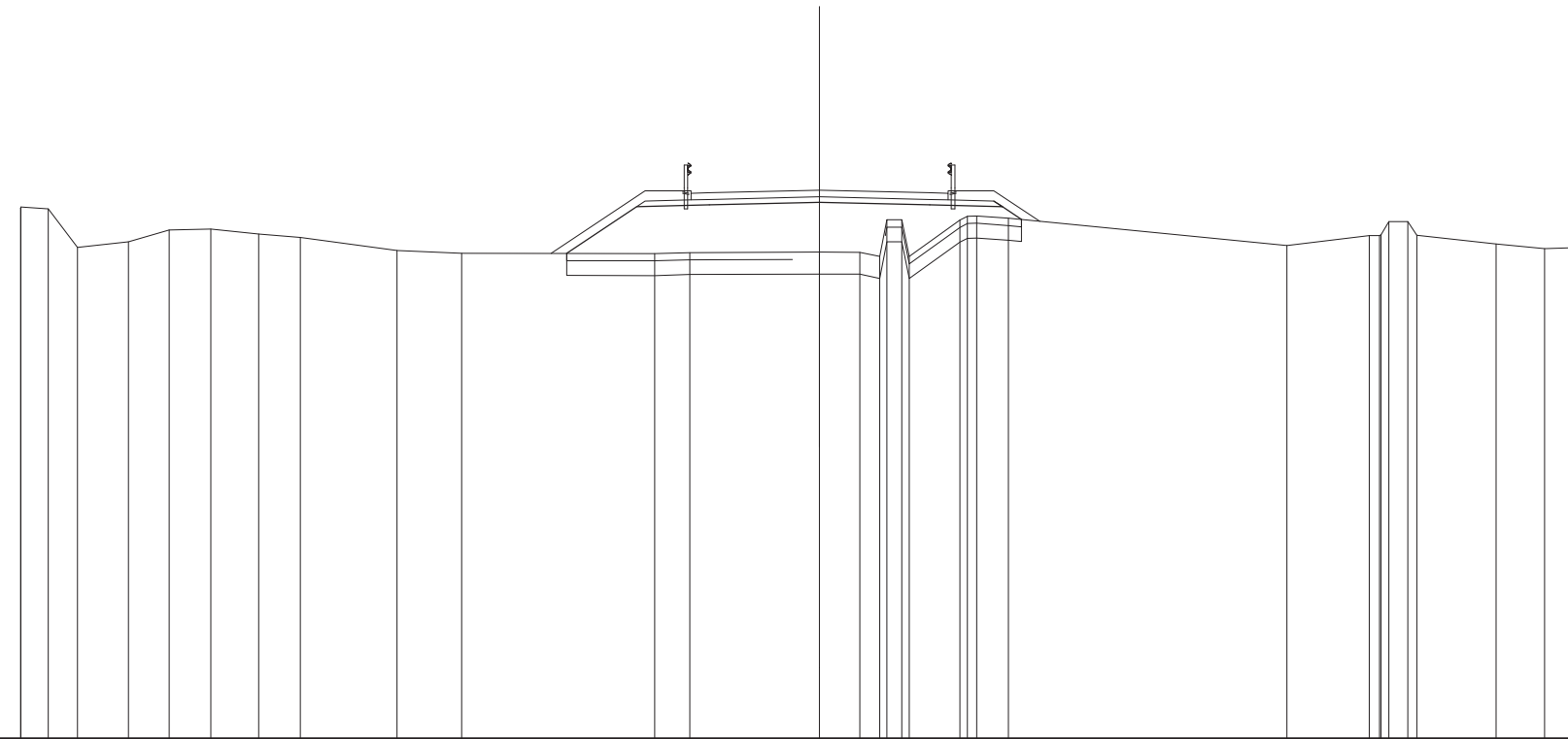

QUOTE TERRENO	434,448 434,461 434,461 433,377 433,529 433,866 433,882 433,746 433,662 433,291 433,219	433,211 433,239 433,253 433,247 433,135 434,134 434,132 433,130 434,122 434,229 434,236 434,175	433,427 433,701 433,701 433,729 434,083 434,061 433,711 433,474 433,344 433,378
DIST.PARZIALI TERRENO	0,743 0,796 1,389 1,108 1,140 1,302 1,132 2,637 1,762	5,257 0,866 3,533 1,100 0,638 0,403 1,380 0,884	7,591 2,242 0,512 2,154 1,327 1,072
QUOTE PROGETTO	433,215 434,486 434,536 434,611 434,536 434,642 434,486 434,139		
DIST.PARZIALI PROGETTO	1,906 1,984 3,000 3,000 1,750 0,620		
QUOTE PAVIMENTATO	434,673 434,653 434,666 434,941 434,666 434,673 434,653		
DIST.PARZIALI PAVIMENTATO	0,600 3,000 3,000 0,600		

SCAVI E BONIFICHE	
STERRO	0,042 m ²
SCOTICO	13,617 m
BONIFICA	5,447 m ²
RILEVATI	
RILEVATO	29,964 m ²
TERRENO VEGETALE	10,275 m
SOVRASTRUTTURA STRADALE	
STRATI LEGATI	7,000 m
STRATO DI FONDAZIONE	1,460 m ²

SEZIONE N.: 38
 QT. PROGETTO: 432,547
 DIST.PROG.: 500,000
 DIST.PREC.: 20,000
 DIST.SUCC.: 20,000

SCALA 1:200

QT.RIF. 420,000

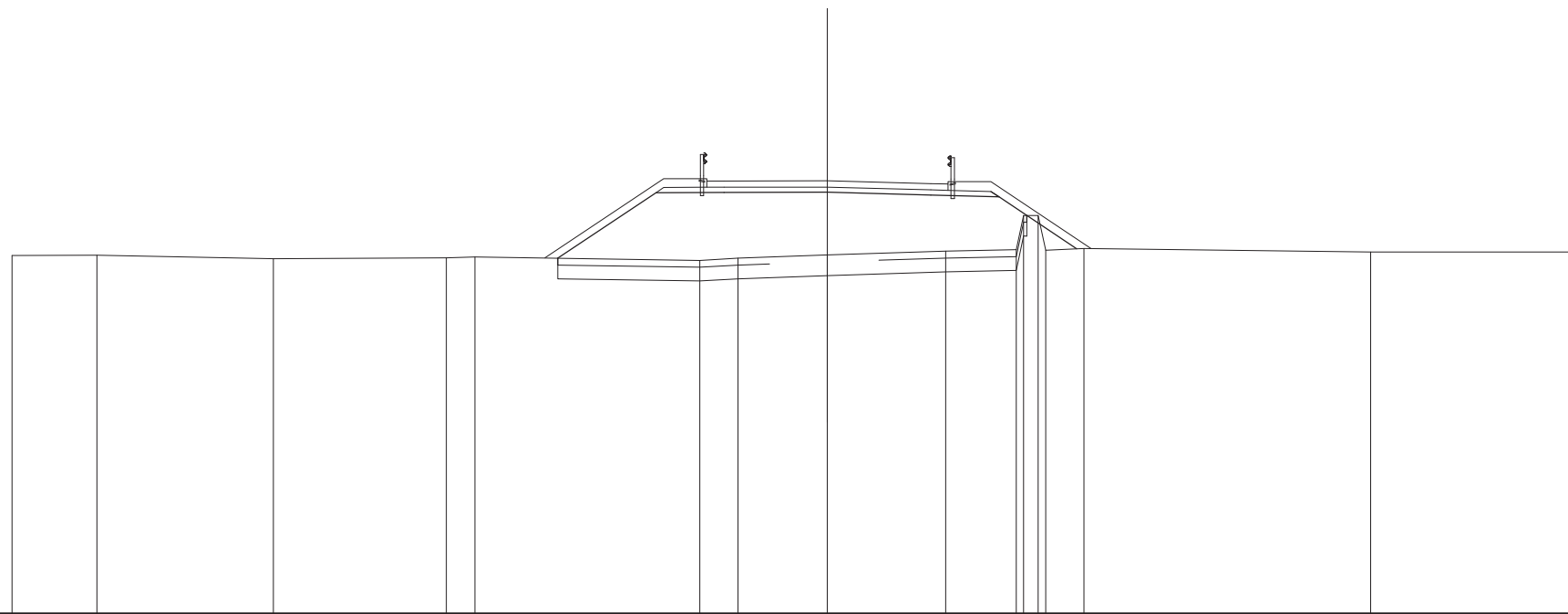

QUOTE TERRENO	430,381	430,388	430,282	430,311	430,341	430,242	430,305	430,395	430,508	430,549	430,546	430,540	430,537	430,588	430,486	430,485
DIST.PARZIALI TERRENO	2,471	5,120	5,024	0,831	6,527	1,107	2,594	3,435	2,046	0,428	1,114	8,323	6,086			
QUOTE PROGETTO						430,305	432,206	432,210	432,217	432,136	432,238	432,082	430,578			
DIST.PARZIALI PROGETTO						2,851	1,976	3,000	3,000	1,750	2,255					
QUOTE PAVIMENTATO							432,359	432,539	432,540	432,547	432,466	432,772	432,452			
DIST.PARZIALI PAVIMENTATO							0,500	3,000	3,000	0,500						

SCAVI E BONIFICHE	
SCOTICO	14,390 m
BONIFICA	5,756 m ²
RILEVATI	
RILEVATO	26,997 m ²
TERRENO VEGETALE	9,406 m
SOVRASTRUTTURA STRADALE	
STRATI LEGATI	7,000 m
STRATO DI FONDAZIONE	1,459 m ²

SEZIONE N.: 47
 QT. PROGETTO: 426,703
 DIST.PROG.: 600,000
 DIST.PREC.: 2,752
 DIST.SUCC.: 6,787

SCALA 1:200

QT.RIF. 410,000

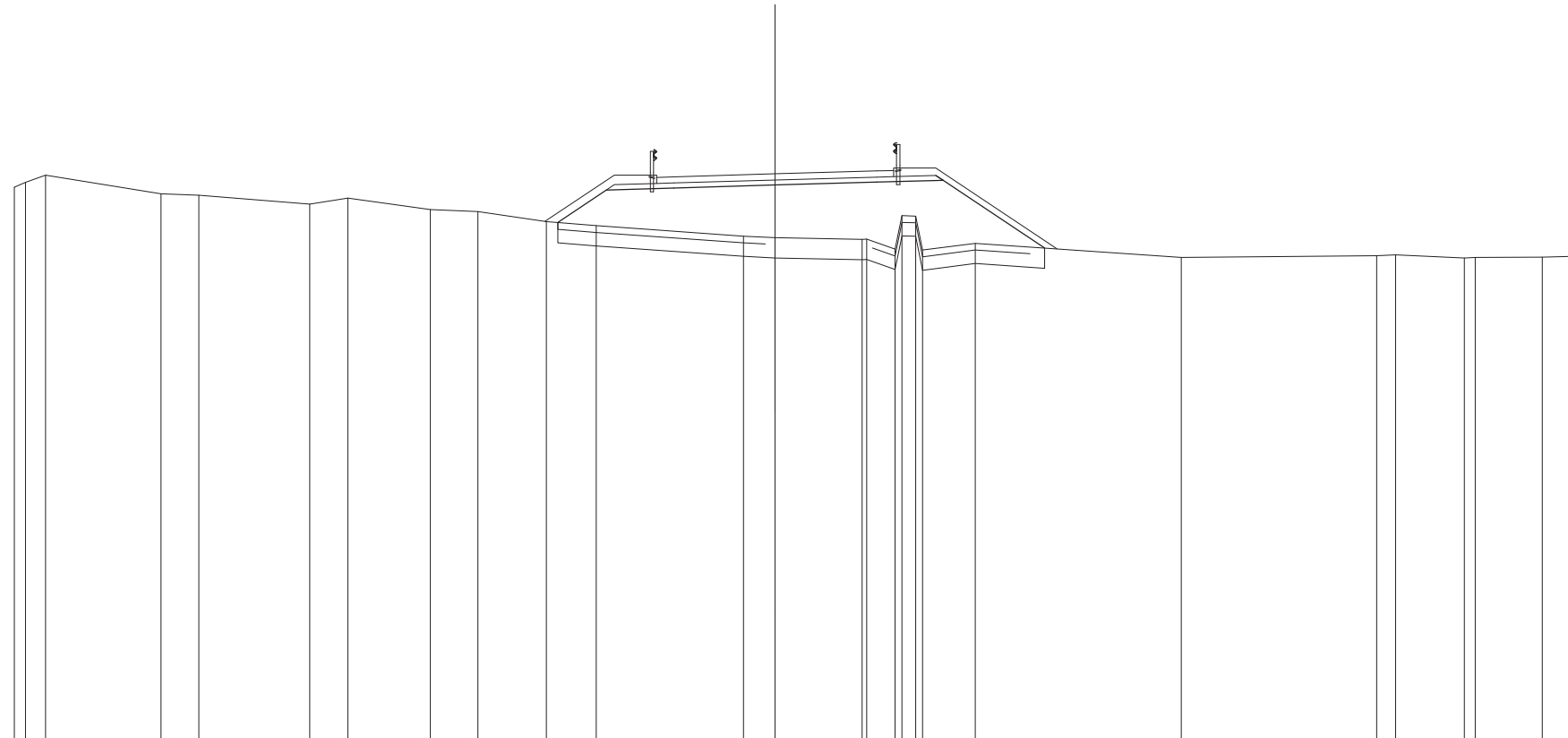

QUOTE TERRENO	426,313 426,457 426,664	426,114 426,071	425,813 425,985	425,650 425,582	425,295 425,176	424,864 424,816	424,705 424,775 424,478 425,471 424,482	424,653	424,232	424,285 424,308	424,215 424,233	424,247 424,273
DIST.PARZIALI TERRENO	0,588 3,412	1,117 3,274	1,194 2,436	1,402 2,026	1,475 4,350	0,698 2,571	0,640 0,408 1,552	6,089	5,777	0,698 2,028	1,982	0,978
QUOTE PROGETTO					425,268 426,225	426,284 426,373	426,459 426,515	424,511				
DIST.PARZIALI PROGETTO					1,435 1,985	3,000 3,000	1,750 3,004					
QUOTE PAVIMENTATO						426,419 426,599 426,614	426,703 426,789 426,823 426,803					
DIST.PARZIALI PAVIMENTATO						0,500 3,000	3,000	0,500				

SCAVI E BONIFICHE	
STERRO	6,663 m ²
RILEVATI	
TERRENO VEGETALE	0,900 m
SOVRASTRUTTURA STRADALE	
STRATI LEGATI	5,307 m
STRATO DI FONDAZIONE	0,796 m ²

SEZIONE N.: 57
 QT. PROGETTO: 416,302
 DIST.PROG.: 732,347
 DIST.PREC.: 8,078
 DIST.SUCC.: 4,222

SCALA 1:200

QT.RIF. 400,000

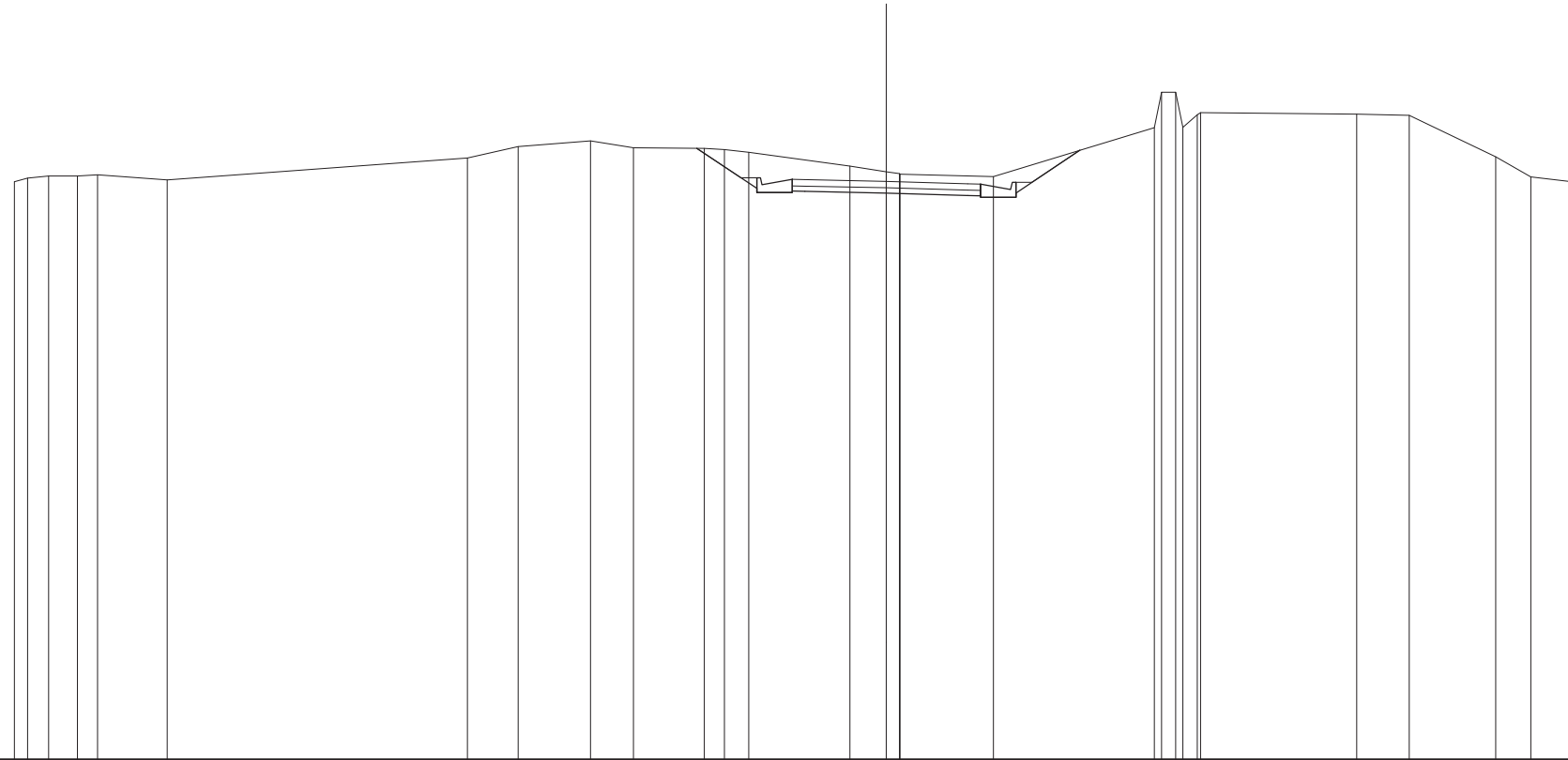

QUOTE TERRENO	416,290 416,301 416,464 416,451 416,490 416,345	416,962 417,285 417,447 417,248 417,234 417,201 417,123 416,732 416,571 416,519 416,507 416,440	417,816 417,817 418,820 417,821 418,181 418,240 418,197 418,163 416,999 416,431 416,288 416,280
DIST.PARZIALI TERRENO	0,693 0,812 0,588 1,966 8,463	1,437 2,037 1,212 1,999 0,582 0,688 2,854 1,023 2,631 4,546	0,400 0,409 4,401 1,488 2,432 0,992 1,160
QUOTE PROGETTO		417,235 415,986 416,106 416,406 415,986 415,989 418,028 418,356 416,019 415,972 415,905 415,854 416,224 415,894 415,854 415,974 416,274 417,179	
DIST.PARZIALI PROGETTO		1,693 0,660 2,295 2,295 0,660 1,806	
QUOTE PAVIMENTATO		416,176 416,366 416,349 416,302 416,235 416,044 416,224	
DIST.PARZIALI PAVIMENTATO		2,295 2,295	

