

**S.S.131 DI "CARLO FELICE"**  
Adeguamento e messa in sicurezza della S.S.131  
Risoluzione dei nodi critici 2° stralcio  
dal km 108+300 al km 158+000

**PROGETTO ESECUTIVO**

CA284

R.T.I. di PROGETTAZIONE:

Mandataria



**PRO  
ITER**  
Progetto  
Infrastrutture  
Territorio s.r.l.

Via G.B. Sammartini n°5  
20125 - Milano  
Tel. 02 6787911  
email: mail@proiter.it

Mandante



Via Artemide n°3  
92100 Agrigento  
Tel. 0922 421007  
email: deltaingegneria@pec.it

PROGETTISTI:

Ing. Riccardo Formichi - Pro Iter srl (Integratore prestazioni specialistiche)  
Ordine Ing. di Milano n. 18045

Ing. Nicola D'Alessandro - Delta Ingegneria srl  
Ordine Ing. di Agrigento n. A995

IL GEOLOGO

Dott. Geol. Massimo Mezzanatica - Pro Iter srl  
Albo Geol. Lombardia n. A762

COORDINATORE PER LA SICUREZZA IN FASE DI PROGETTAZIONE

Ing. Diego Ceccherelli  
Ordine Ing. di Milano n. 15813

VISTO: IL RESP. DEL PROCEDIMENTO

Dott. Ing. Salvatore Frasca

PROTOCOLLO

DATA



**PROGETTO STRADALE**  
Risoluzione accesso C. S. al Km 141+235  
Sezioni trasversali

CODICE PROGETTO

PROGETTO LIV. PROG. N. PROG.

LOPLSQ E 1901

NOME FILE

S11PS00TRASZ01\_C

CODICE  
ELAB.

S11PS00TRASZ01

REVISIONE

SCALA

C

varie

REV.	DESCRIZIONE	DATA	REDATTO	VERIFICATO	APPROVATO
D					
C	REVISIONE PER ISTRUTTORIA, VERIFICA E CONTROLLI D.LGS. 35/11	Agosto 2020	Ing.D. D'ALESSANDRO	Ing. M. CARLINO	Ing.N. D'ALESSANDRO
B	Emissione	Marzo 2020	Ing.D. D'ALESSANDRO	Ing. M. CARLINO	Ing.N. D'ALESSANDRO
A	Emissione per controlli D.LGS. 35/2011	Novembre 2019	Ing.D. D'ALESSANDRO	Ing. M. CARLINO	Ing.N. D'ALESSANDRO

<b>SCAVI E BONIFICHE</b>	
STERRO	3,895 m <sup>2</sup>
BONIFICA	0,804 m <sup>2</sup>
<b>RILEVATI</b>	
RILEVATO	0,804 m <sup>2</sup>
TERRENO VEGETALE	0,900 m
<b>SOVRASTRUTTURA STRADALE</b>	
STRATI LEGATI	7,000 m
STRATO DI FONDAZIONE	1,050 m <sup>2</sup>

SEZIONE N.: 1  
 QT. PROGETTO: 478,654  
 DIST.PROG.: 0,000  
 DIST.SUCC.: 27,500

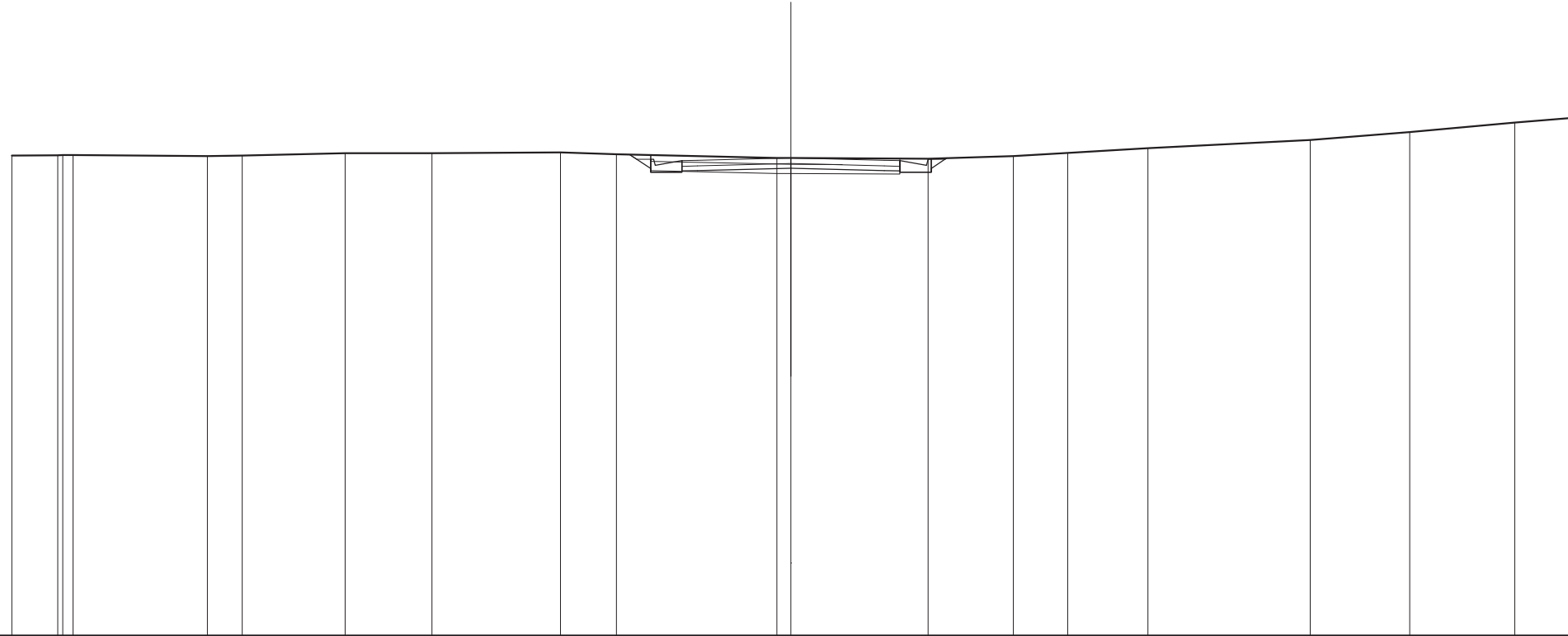

SCALA 1:200

QT.RIF. 463,336

QUOTE TERRENO	478,731	478,741 478,746 478,748	478,717	478,727	478,807	478,811	478,832	478,769	478,656 478,654	478,633	478,718	478,815	478,967	479,232	479,486	479,790	479,935
DIST.PARZIALI TERRENO	1,475	4,312	1,123	3,298	2,787	4,123	1,796	5,151	0,447	4,404	2,732	1,749	2,572	5,211	3,189	3,374	1,770
QUOTE PROGETTO								478,760 478,196 478,316 478,616 478,196 478,196 478,236 478,566 478,249	478,324	478,249 478,196 478,236 478,566 478,616 478,316 478,651							
DIST.PARZIALI PROGETTO								0,684 0,650 0,600	3,000	3,000	0,500 0,650 0,502						
QUOTE PAVIMENTATO								478,386 478,556 478,579	478,654	478,579 478,388 478,566							
DIST.PARZIALI PAVIMENTATO								0,500	3,000	3,000	0,500						



















SCAVI E BONIFICHE	
STERRO	1,963 m <sup>2</sup>
SCOTICO	9,555 m
BONIFICA	3,926 m <sup>2</sup>
RILEVATI	
RILEVATO	14,773 m <sup>2</sup>
TERRENO VEGETALE	5,105 m
SOVRASTRUTTURA STRADALE	
STRATI LEGATI	7,000 m
STRATO DI FONDAZIONE	1,255 m <sup>2</sup>

SEZIONE N.: 10  
 QT. PROGETTO: 476,533  
 DIST.PROG.: 148,016  
 DIST.PREC.: 14,252  
 DIST.SUCC.: 11,984

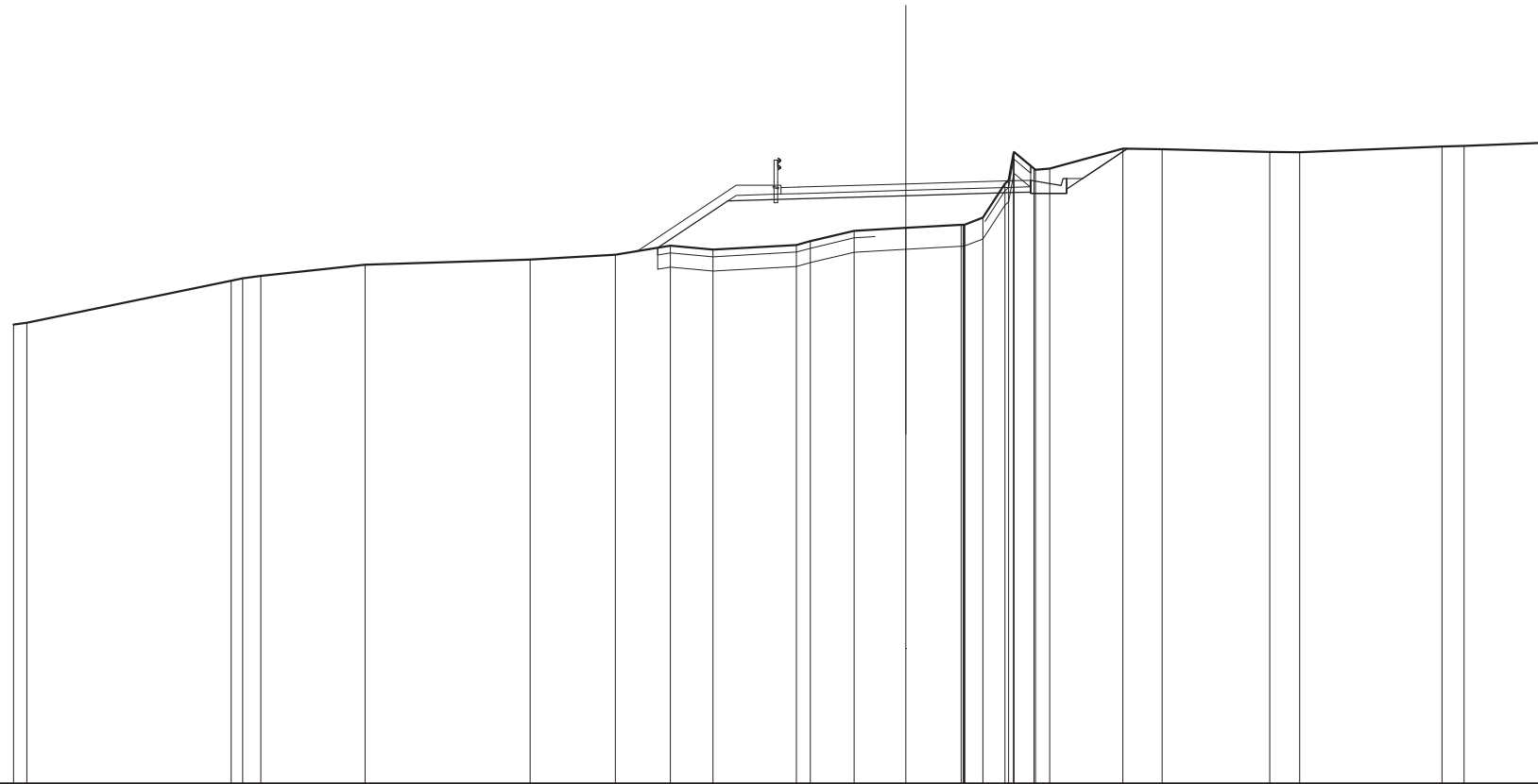

SCALA 1:200

QT.RIF. 459,740

QUOTE TERRENO	472,598 472,644	473,823 473,862 473,969	474,273	474,416	474,547	474,802	474,684	474,823 474,930	475,222	475,302	475,387 475,391 475,392 475,392 475,594 475,594 476,631 477,377 477,430 476,960 476,929 476,957 477,502 477,502	477,433 477,422	477,584 477,602	477,683 477,684		
DIST.PARZIALI TERRENO	5,719	0,616 2,919	4,624	2,388	1,541	1,194	2,336	0,392 1,224	1,449	1,547	0,609 0,615 0,664 0,401	2,046	1,100	3,019	0,634 3,987	0,623 2,165
QUOTE PROGETTO						474,743	476,054	476,113		476,203		476,292 476,287 476,307 476,307 476,287 476,987 476,387 477,524				
DIST.PARZIALI PROGETTO						1,965	1,985	3,000		3,000	0,600 0,660	1,704				
QUOTE PAVIMENTATO								476,248 476,428 476,443		476,533		476,622 476,457 476,637				
DIST.PARZIALI PAVIMENTATO								0,600	3,000	3,000	0,600					

<b>SCAVI E BONIFICHE</b>	
STERRO	2,778 m <sup>2</sup>
SCOTICO	10,484 m
BONIFICA	3,330 m <sup>2</sup>
<b>RILEVATI</b>	
RILEVATO	15,560 m <sup>2</sup>
TERRENO VEGETALE	5,882 m
<b>SOVRASTRUTTURA STRADALE</b>	
STRATI LEGATI	7,000 m
STRATO DI FONDAZIONE	1,255 m <sup>2</sup>

SEZIONE N.: 11  
 QT. PROGETTO: 476,316  
 DIST.PROG.: 160,000  
 DIST.PREC.: 11,984  
 DIST.SUCC.: 20,000

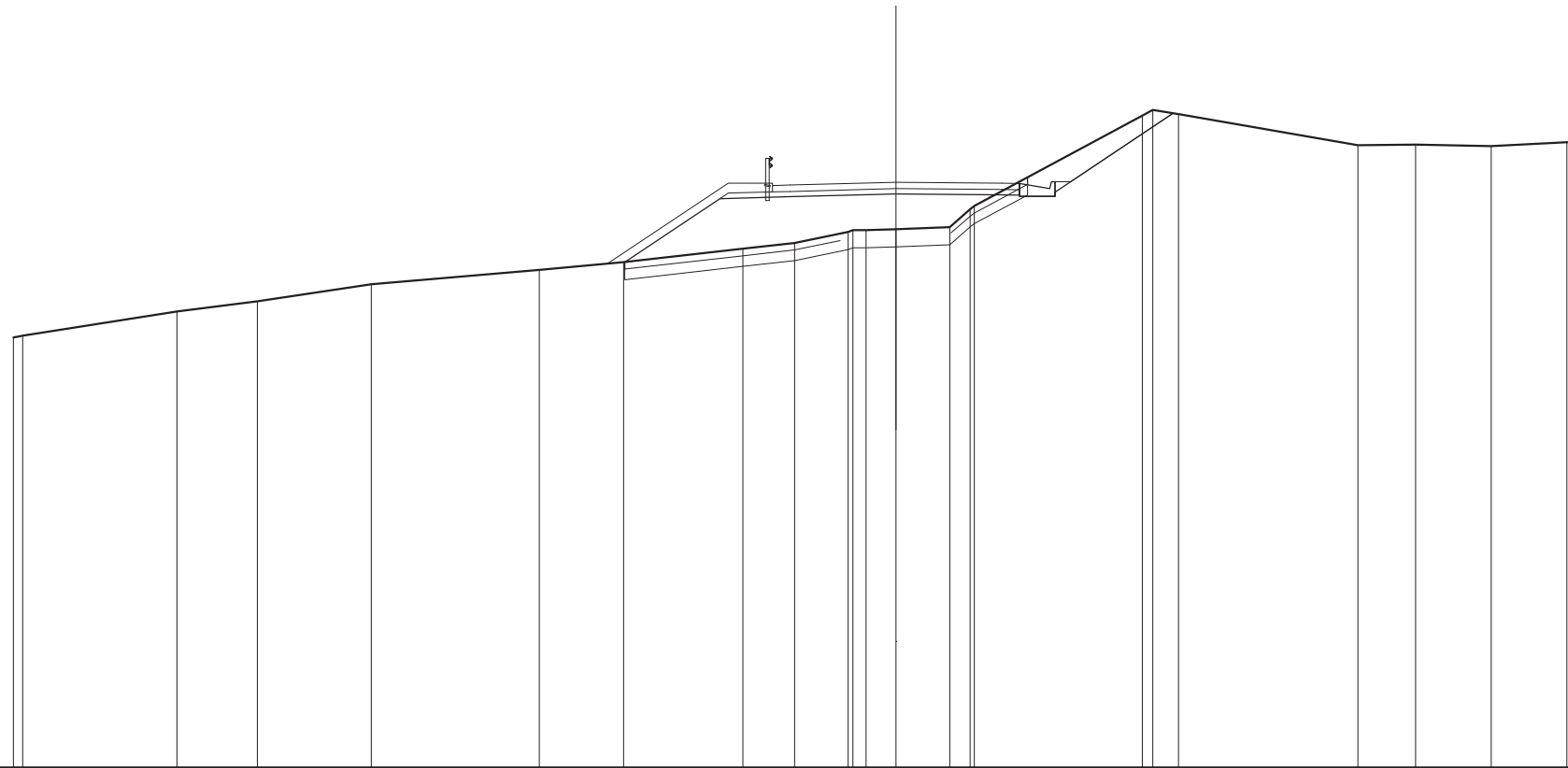

SCALA 1:200

QT.RIF. 459,744

QUOTE TERRENO	471,924 471,970	472,666	472,960	473,429	473,836	474,063	474,433	474,601	474,910 474,959 474,957	474,980	475,060 475,553 475,643	478,200 478,365	478,245	477,368	477,385	477,342	477,460 477,461	
DIST.PARZIALI TERRENO	4,376	2,280	3,224	4,758	2,385	3,376	1,470	1,513	0,846	1,519	0,580	4,760	0,728	5,083	1,631	2,141	2,150	0,400
QUOTE PROGETTO						474,057	475,854	475,907		475,986		475,959 475,914 475,954 476,104 476,284 475,914 476,034 476,034	478,270					
DIST.PARZIALI PROGETTO						2,694	1,984	3,000		3,000	0,600 0,660	3,352						
QUOTE PAVIMENTATO										476,043 476,223 476,237		476,316						
DIST.PARZIALI PAVIMENTATO								0,600	3,000		3,000	0,600						





<b>SCAVI E BONIFICHE</b>	
SCOTICO	13,161 m
BONIFICA	3,948 m <sup>2</sup>
<b>RILEVATI</b>	
RILEVATO	20,677 m <sup>2</sup>
TERRENO VEGETALE	7,759 m
<b>SOVRASTRUTTURA STRADALE</b>	
STRATI LEGATI	7,000 m
STRATO DI FONDAZIONE	1,459 m <sup>2</sup>

SEZIONE N.: 14  
 QT. PROGETTO: 478,298  
 DIST.PROG.: 226,761  
 DIST.PREC.: 26,761  
 DIST.SUCC.: 10,940

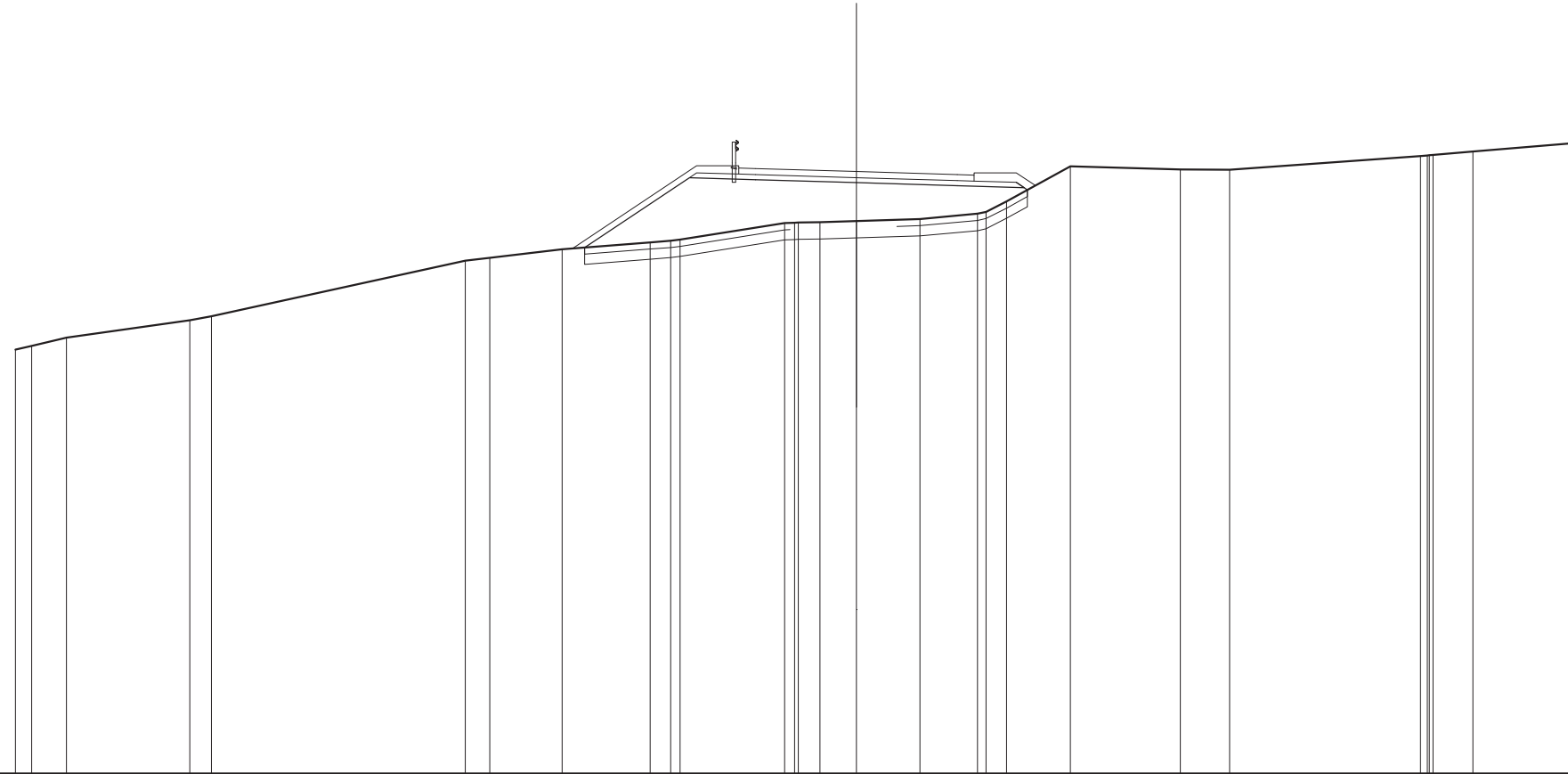

SCALA 1:200

QT.RIF. 460,417

QUOTE TERRENO	473,011 473,121 473,366	473,880 474,000	475,661 475,733	475,989	476,194 476,242 476,275	476,766 476,779 476,763 476,782	476,828	476,880	477,044 477,102 477,411	478,463	478,368 478,353	478,762 478,766 478,768 478,792	478,891	479,162
DIST.PARZIALI TERRENO	0,485 1,033	3,668	0,643	7,542	0,731 2,152	2,616	0,607 3,113	0,648 1,081	1,888 1,709	0,610 1,901	3,265 1,469	5,666	1,186 3,266	
QUOTE PROGETTO					476,041	476,117	476,058	477,968	477,878	477,975 477,818 477,752				
DIST.PARZIALI PROGETTO						3,111	1,965	3,000	3,000	1,750				
QUOTE PAVIMENTATO							478,223 478,403 478,368	478,298	478,208 478,013 478,193					
DIST.PARZIALI PAVIMENTATO							0,500	3,000	3,000	0,500				







<b>SCAVI E BONIFICHE</b>	
SCOTICO	11,892 m
BONIFICA	4,757 m <sup>2</sup>
<b>RILEVATI</b>	
RILEVATO	12,393 m <sup>2</sup>
TERRENO VEGETALE	5,762 m
<b>SOVRASTRUTTURA STRADALE</b>	
STRATI LEGATI	7,547 m
STRATO DI FONDAZIONE	1,541 m <sup>2</sup>

SEZIONE N.: 17  
 QT. PROGETTO: 481,139  
 DIST.PROG.: 269,445  
 DIST.PREC.: 20,805  
 DIST.SUCC.: 6,651

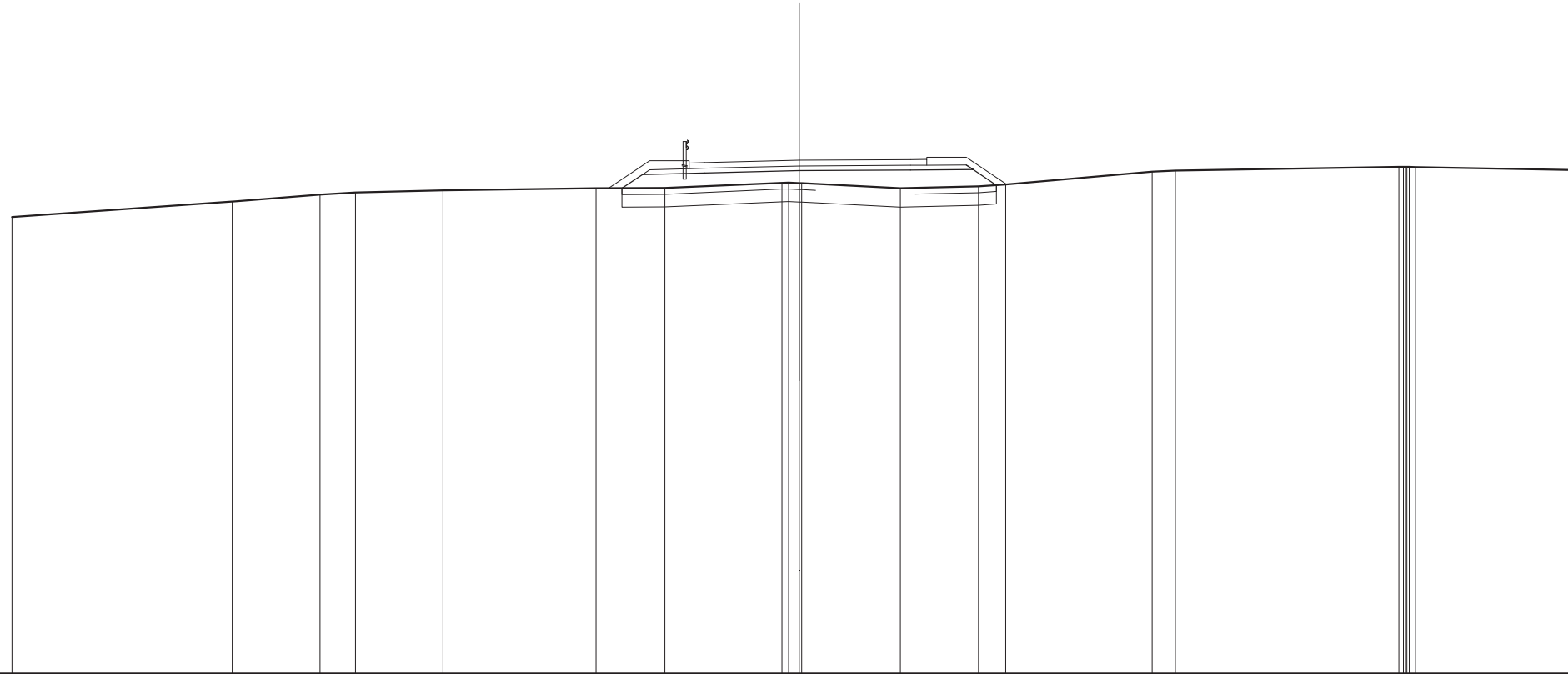

SCALA 1:200

QT.RIF. 464,858

QUOTE TERRENO	479,340	479,829 479,852	480,050	480,119	480,185	480,249	480,259	480,424 480,431 480,413 480,410	480,253	480,310 480,370	480,781 480,813	480,833 480,830 480,829 480,930 480,925	480,831	
DIST.PARZIALI TERRENO	6,994	2,766	1,128	2,779	4,854	2,185	3,721	3,135	2,482	0,881	4,652	0,737	7,090	5,086
QUOTE PROGETTO						480,252 480,685	480,734	480,809	480,831	480,992 480,844 480,350				
DIST.PARZIALI PROGETTO						0,848	1,984	3,000	3,533	1,764	0,740			
QUOTE PAVIMENTATO							481,052 480,872 481,064	481,139	481,161 480,985 481,165					
DIST.PARZIALI PAVIMENTATO							0,500	3,000	3,533	0,514				

<b>SCAVI E BONIFICHE</b>	
SCOTICO	27,353 m
BONIFICA	10,941 m <sup>2</sup>
<b>RILEVATI</b>	
RILEVATO	30,207 m <sup>2</sup>
TERRENO VEGETALE	5,905 m
<b>SOVRASTRUTTURA STRADALE</b>	
STRATI LEGATI	22,870 m
STRATO DI FONDAZIONE	3,839 m <sup>2</sup>

SEZIONE N.: 18  
 QT. PROGETTO: 481,410  
 DIST.PROG.: 276,097  
 DIST.PREC.: 6,651  
 DIST.SUCC.: 6,651

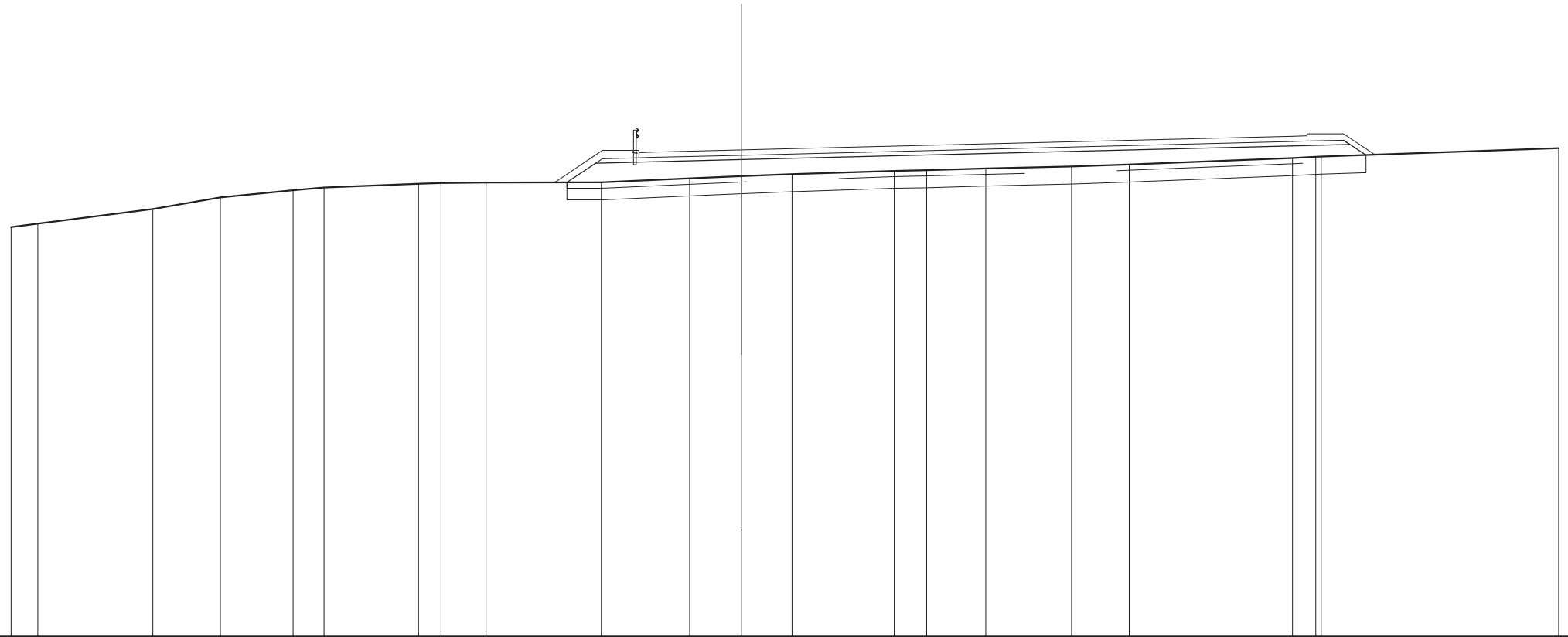

SCALA 1:200

QT.RIF. 464,756

QUOTE TERRENO	478,770	478,886		478,386	478,790	480,033	480,125		480,252	480,275	480,286		480,301		480,439	480,511	480,581		480,686	480,721	480,774		480,843	480,914		481,136	481,177	481,180		481,468
DIST.PARZIALI TERRENO	0,916	3,939	2,315	2,483	1,069	3,241	0,789	1,538	3,952	3,019	1,771	1,736	3,494	1,112	2,027	2,935	1,970	5,589	0,798						8,133					
QUOTE PROGETTO									480,299	480,955	481,004	481,080														481,551	481,745	481,600	481,234	
DIST.PARZIALI PROGETTO									0,663	1,984	3,008					18,863									1,750	0,549				
QUOTE PAVIMENTATO													481,142	481,322	481,354	481,410										481,581	481,744	481,584		
DIST.PARZIALI PAVIMENTATO													0,660	3,008		18,863									0,600					

<b>SCAVI E BONIFICHE</b>	
SCOTICO	11,515 m
BONIFICA	3,455 m <sup>2</sup>
<b>RILEVATI</b>	
RILEVATO	12,935 m <sup>2</sup>
TERRENO VEGETALE	6,602 m
<b>SOVRASTRUTTURA STRADALE</b>	
STRATI LEGATI	6,482 m
STRATO DI FONDAZIONE	1,381 m <sup>2</sup>

SEZIONE N.: 19  
 QT. PROGETTO: 481,617  
 DIST.PROG.: 282,748  
 DIST.PREC.: 6,651  
 DIST.SUCC.: 17,252

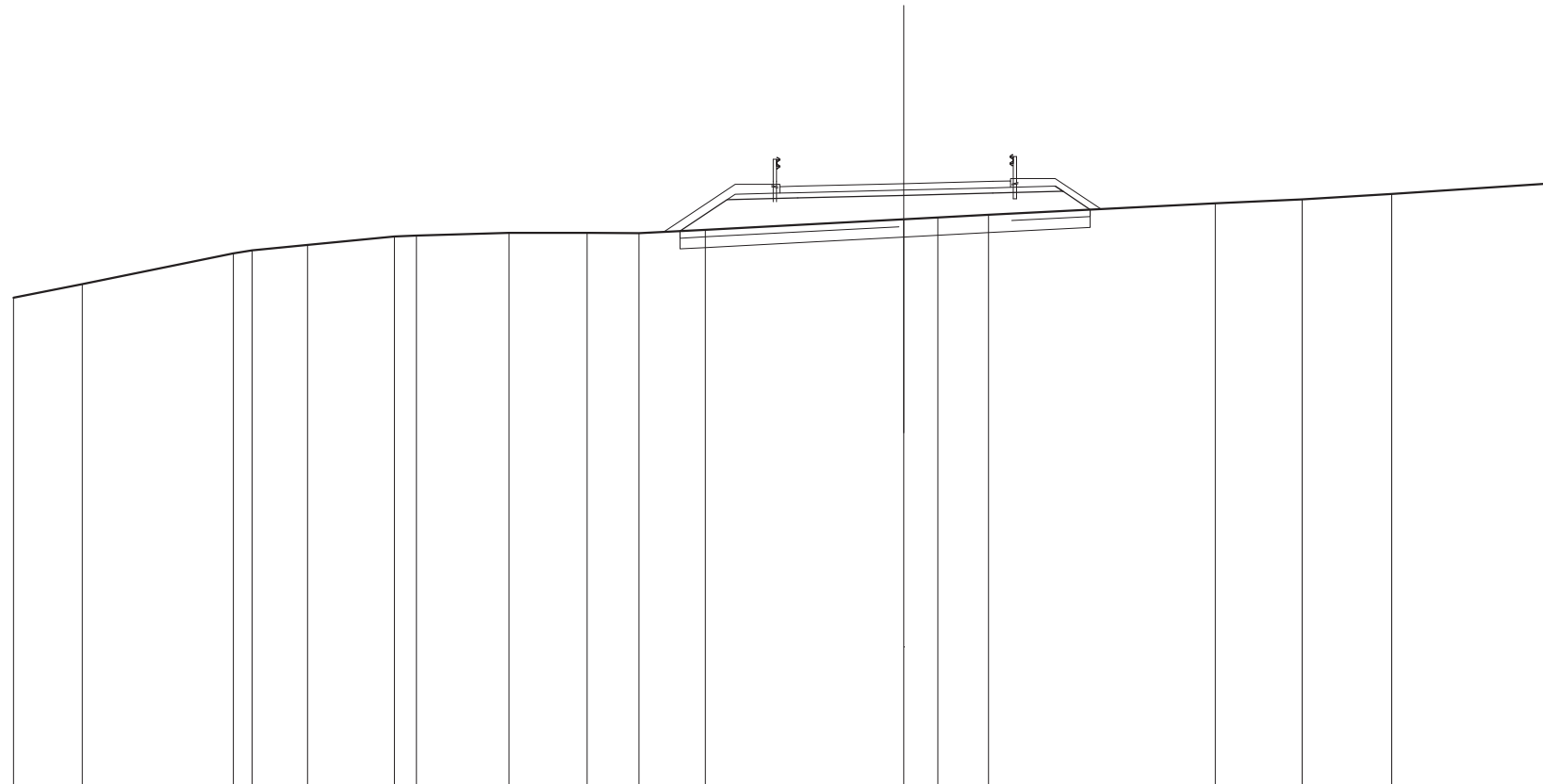

SCALA 1:200

QT.RIF. 464,720

QUOTE TERRENO	478,411	478,792	479,668	479,744	479,896	480,130	480,159	480,233	480,237	480,224	480,321	480,613	480,663	480,745	481,061	481,171	481,326	481,635
DIST.PARZIALI TERRENO	1,932	4,246	0,522	1,559	2,436	0,623	2,597	2,193	1,456	1,863	5,574	0,964	1,422	6,367	2,438	2,518	4,730	
QUOTE PROGETTO											480,284	481,162	481,212	481,287	481,349	481,543	481,398	480,887
DIST.PARZIALI PROGETTO											1,316	1,985	2,979	2,499	1,751	0,767		
QUOTE PAVIMENTATO											481,530	481,350	481,542	481,617	481,679	481,692	481,512	
DIST.PARZIALI PAVIMENTATO											0,502	2,979	2,499	0,501				

<b>SCAVI E BONIFICHE</b>	
SCOTICO	10,226 m
BONIFICA	4,090 m <sup>2</sup>
<b>RILEVATI</b>	
RILEVATO	14,408 m <sup>2</sup>
TERRENO VEGETALE	7,796 m
<b>SOVRASTRUTTURA STRADALE</b>	
STRATI LEGATI	4,000 m
STRATO DI FONDAZIONE	1,039 m <sup>2</sup>

SEZIONE N.: 20  
 QT. PROGETTO: 481,859  
 DIST.PROG.: 300,000  
 DIST.PREC.: 17,252  
 DIST.SUCC.: 10,347

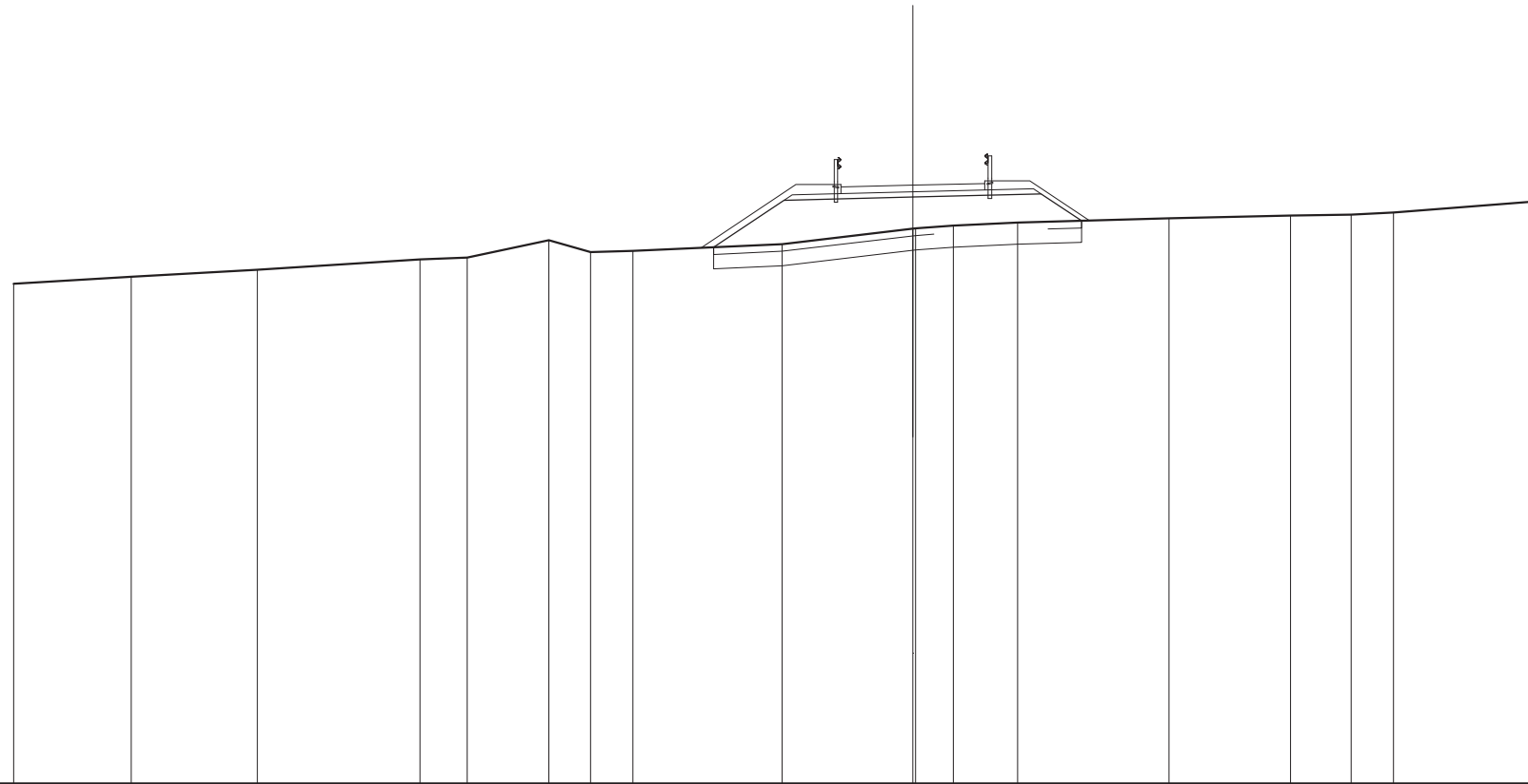

SCALA 1:200

QT.RIF. 465,223

QUOTE TERRENO	479,118	479,315	479,508	479,800	479,844	480,333	479,987	480,035	480,222	480,650	480,659	480,734	480,819	480,941	481,015	481,041	481,087	481,426
DIST.PARZIALI TERRENO	3,267	3,514	4,517	1,309	2,271	1,156	1,176	4,153	3,633	1,060	1,790	4,209	3,379	1,682	1,176	4,128		
QUOTE PROGETTO									480,136	481,439	481,529		481,618	480,870				
DIST.PARZIALI PROGETTO									1,954	3,584	3,567	1,121						
QUOTE PAVIMENTATO										481,629	481,809	481,859	481,909	481,729				
DIST.PARZIALI PAVIMENTATO										2,000	2,000							

<b>SCAVI E BONIFICHE</b>	
SCOTICO	10,298 m
BONIFICA	4,119 m <sup>2</sup>
<b>RILEVATI</b>	
RILEVATO	15,711 m <sup>2</sup>
TERRENO VEGETALE	7,855 m
<b>SOVRASTRUTTURA STRADALE</b>	
STRATI LEGATI	4,000 m
STRATO DI FONDAZIONE	1,039 m <sup>2</sup>

SEZIONE N.: 21  
 QT. PROGETTO: 481,800  
 DIST.PROG.: 310,347  
 DIST.PREC.: 10,347  
 DIST.SUCC.: 14,248

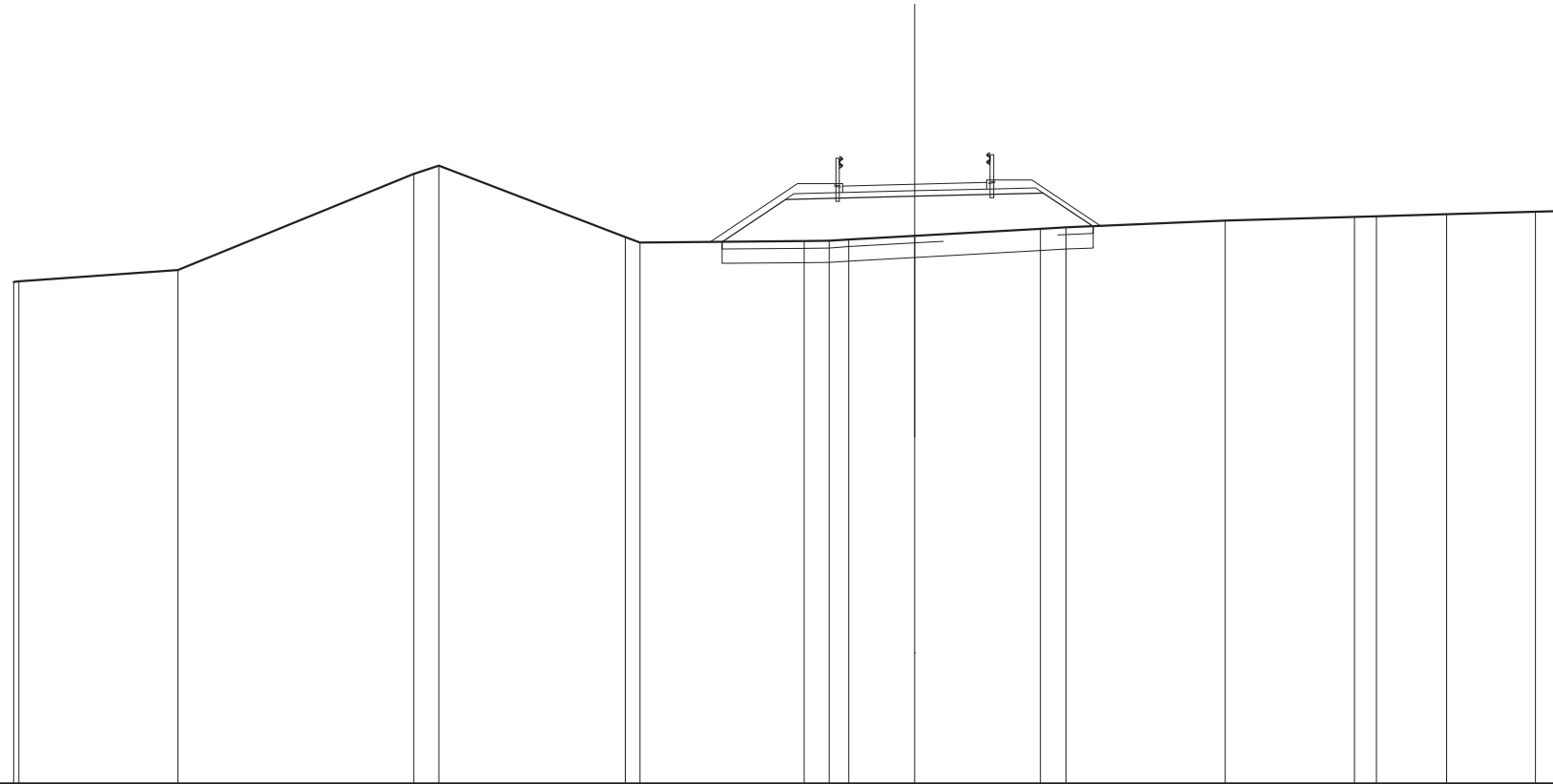

SCALA 1:200

QT.RIF. 465,179

QUOTE TERRENO	479,088 478,106	479,423	482,089 482,316	480,340 480,186	480,225 480,233 480,270	480,373	480,568 480,604	480,791	480,885 480,916	480,968	481,036 481,056					
DIST.PARZIALI TERRENO	4,410	6,553	0,688	5,173	0,412	4,553	0,681 0,540	1,833	3,489	0,708	4,416	3,590	0,611	1,942	2,471	0,615
QUOTE PROGETTO						480,205	481,381	481,470	481,560	480,636						
DIST.PARZIALI PROGETTO							1,763	3,584	3,567	1,385						
QUOTE PAVIMENTATO							481,570 481,750	481,800	481,670 481,850							
DIST.PARZIALI PAVIMENTATO								2,000	2,000							









<b>SCAVI E BONIFICHE</b>	
SCOTICO	9,664 m
BONIFICA	3,866 m <sup>2</sup>
<b>RILEVATI</b>	
RILEVATO	12,213 m <sup>2</sup>
TERRENO VEGETALE	7,124 m
<b>SOVRASTRUTTURA STRADALE</b>	
STRATI LEGATI	4,000 m
STRATO DI FONDAZIONE	1,039 m <sup>2</sup>

SEZIONE N.: 25  
 QT. PROGETTO: 478,175  
 DIST.PROG.: 380,000  
 DIST.PREC.: 20,000  
 DIST.SUCC.: 21,842

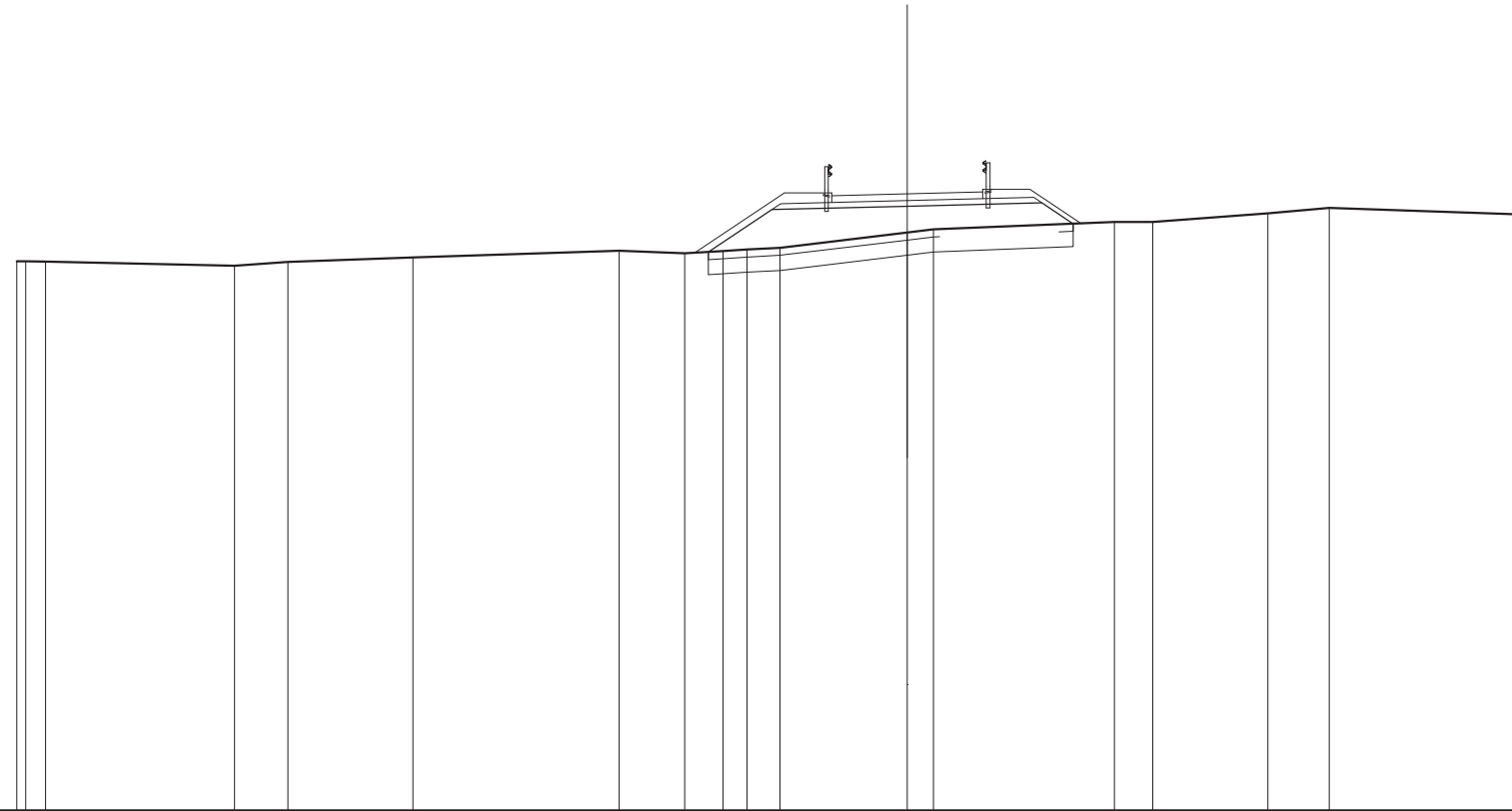

SCALA 1:200

QT.RIF. 461,838

QUOTE TERRENO	476,385 476,383 476,377		476,270	476,371	476,485		476,686	476,587	476,654 476,688 476,744	477,148 477,231		477,424 477,428	477,660	477,803		477,624
DIST.PARZIALI TERRENO	0,521	5,002	1,414	3,318		5,455	1,741	1,014 0,638 0,871	3,369	0,691	4,792	1,022	3,044	1,624	5,218	
QUOTE PROGETTO								476,632 477,755		477,845		477,934 477,380				
DIST.PARZIALI PROGETTO								1,683	3,584	3,567	0,630					
QUOTE PAVIMENTATO										477,945 478,125	478,175		478,045 478,225			
DIST.PARZIALI PAVIMENTATO										2,000	2,000					

<b>SCAVI E BONIFICHE</b>	
SCOTICO	8,745 m
BONIFICA	3,498 m <sup>2</sup>
<b>RILEVATI</b>	
RILEVATO	9,475 m <sup>2</sup>
TERRENO VEGETALE	6,003 m
<b>SOVRASTRUTTURA STRADALE</b>	
STRATI LEGATI	4,000 m
STRATO DI FONDAZIONE	1,039 m <sup>2</sup>

SEZIONE N.: 26  
 QT. PROGETTO: 476,726  
 DIST.PROG.: 401,842  
 DIST.PREC.: 21,842  
 DIST.SUCC.: 20,555

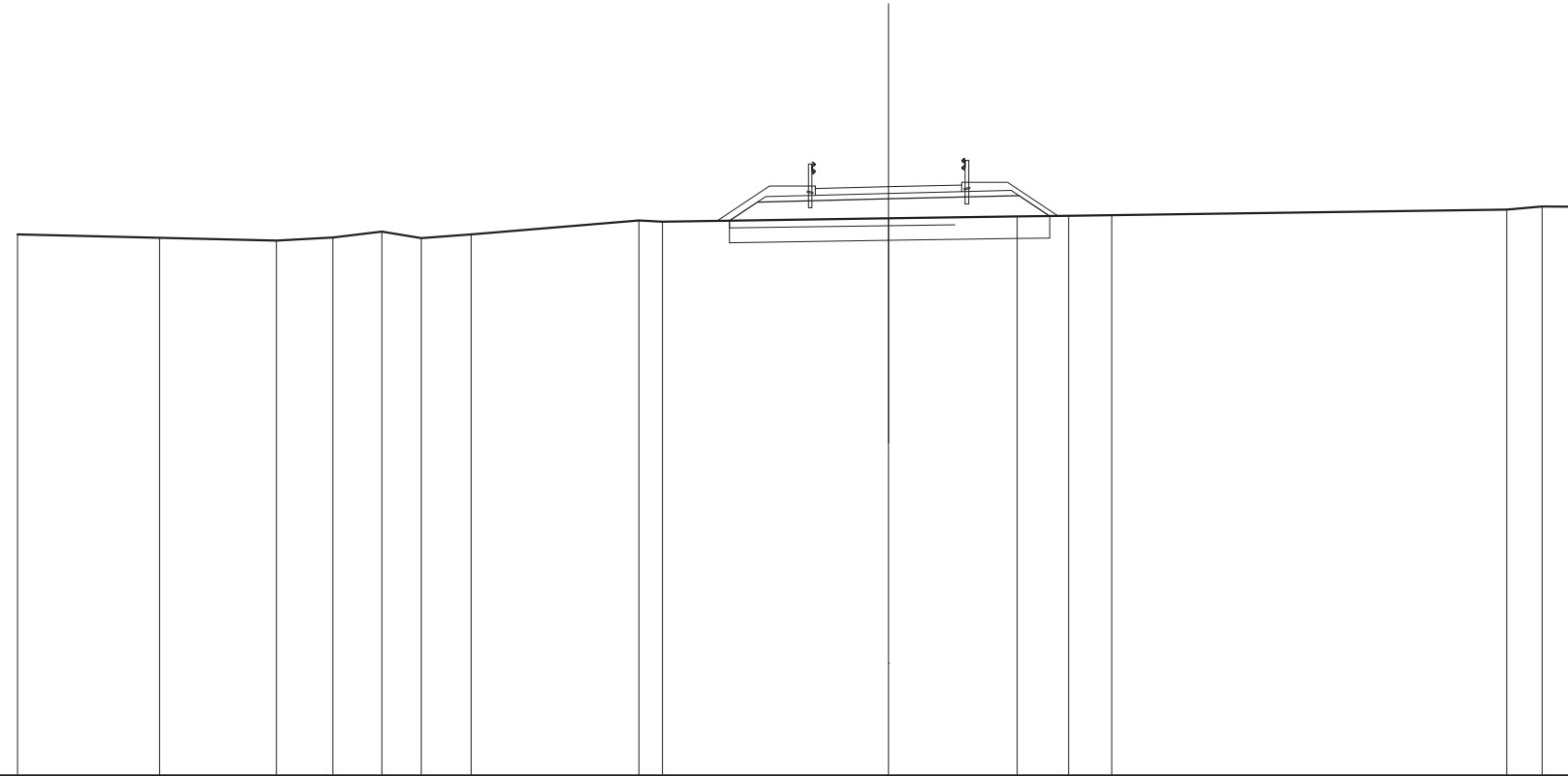

SCALA 1:200

QT.RIF. 460,650

QUOTE TERRENO	475,428	475,336	475,256	475,345	475,500	475,323	475,428	475,806	475,774	475,864	475,916	475,934	475,950	476,107	476,185	476,181
DIST.PARZIALI TERRENO	3,877	3,194	1,540	1,338	1,078	1,361	4,587	0,638	6,175	3,515	1,403	1,177	10,791	0,983	1,157	
QUOTE PROGETTO									475,801	475,396	476,486	475,927				
DIST.PARZIALI PROGETTO									0,798	3,584	3,567	0,837				
QUOTE PAVIMENTATO										476,496	476,726	476,596	476,776			
DIST.PARZIALI PAVIMENTATO										2,000	2,000					



<b>SCAVI E BONIFICHE</b>	
STERRO	0,481 m <sup>2</sup>
SCOTICO	1,686 m
BONIFICA	3,156 m <sup>2</sup>
<b>RILEVATI</b>	
RILEVATO	4,750 m <sup>2</sup>
TERRENO VEGETALE	5,490 m
<b>SOVRASTRUTTURA STRADALE</b>	
STRATI LEGATI	4,000 m
STRATO DI FONDAZIONE	1,039 m <sup>2</sup>

SEZIONE N.: 28  
 QT. PROGETTO: 474,001  
 DIST.PROG.: 442,952  
 DIST.PREC.: 20,555  
 DIST.SUCC.: 17,048

SCALA 1:200

QT.RIF. 457,368

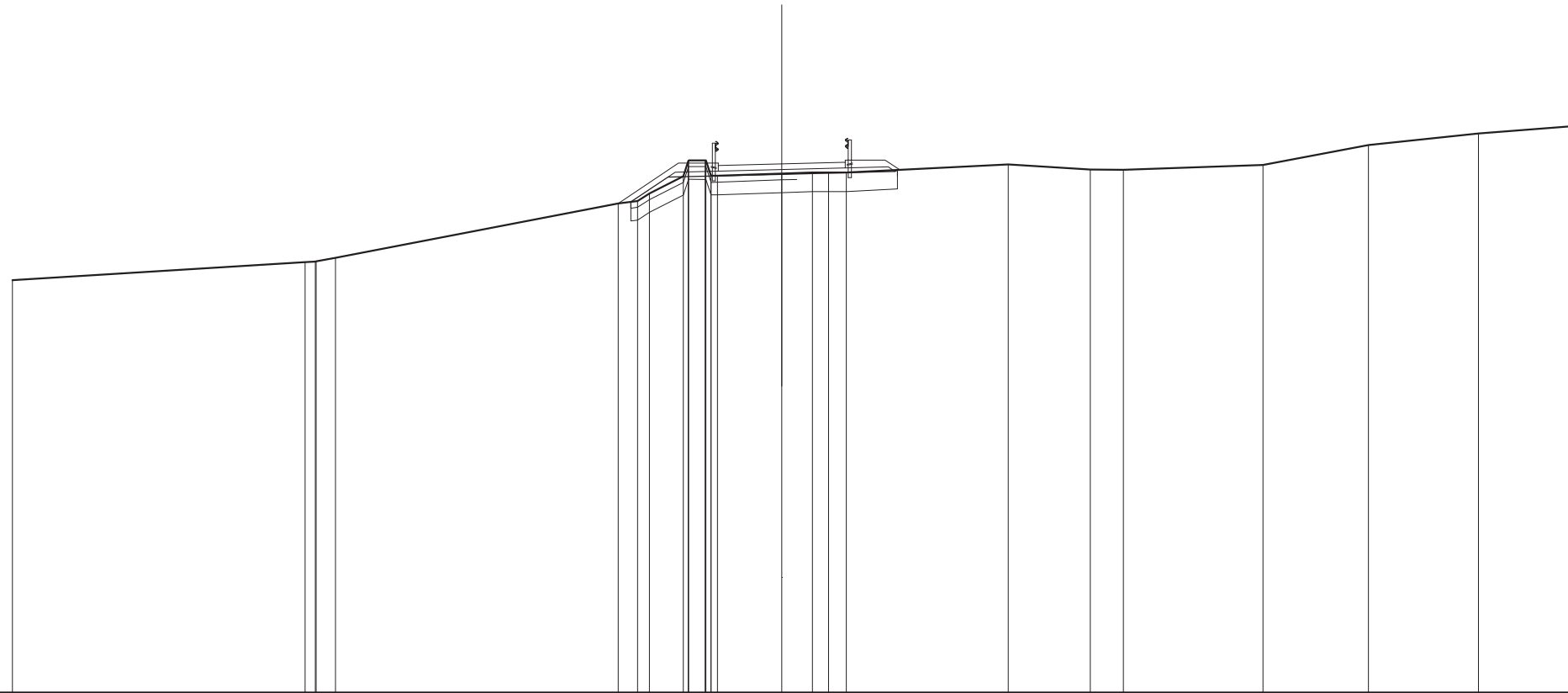

QUOTE TERRENO	470,339	470,904 470,924 470,929 471,045	472,750 472,832 473,071	473,612 474,012 474,111 474,111 473,626 473,611 473,627 473,685	473,728 473,724 473,727	473,963	473,821 473,814	473,965	474,583	474,965	475,197		
DIST.PARZIALI TERRENO	9,215	0,608	8,903	0,606 1,071 0,522	2,024	0,985 0,508 0,582	5,097	2,580	1,040	4,399	3,316	3,465	3,069
QUOTE PROGETTO			472,804 473,581	473,671	473,760 473,808								
DIST.PARZIALI PROGETTO			1,166	3,584	3,567								
QUOTE PAVIMENTATO				473,771 473,951	474,001	473,871 474,051							
DIST.PARZIALI PAVIMENTATO				2,000	2,000								



<b>SCAVI E BONIFICHE</b>	
SCOTICO	8,929 m
BONIFICA	3,572 m <sup>2</sup>
<b>RILEVATI</b>	
RILEVATO	9,858 m <sup>2</sup>
TERRENO VEGETALE	6,200 m
<b>SOVRASTRUTTURA STRADALE</b>	
STRATI LEGATI	4,000 m
STRATO DI FONDAZIONE	1,039 m <sup>2</sup>

SEZIONE N.: 30  
 QT. PROGETTO: 471,544  
 DIST.PROG.: 480,000  
 DIST.PREC.: 20,000  
 DIST.SUCC.: 20,000

SCALA 1:200

QT.RIF. 455,240

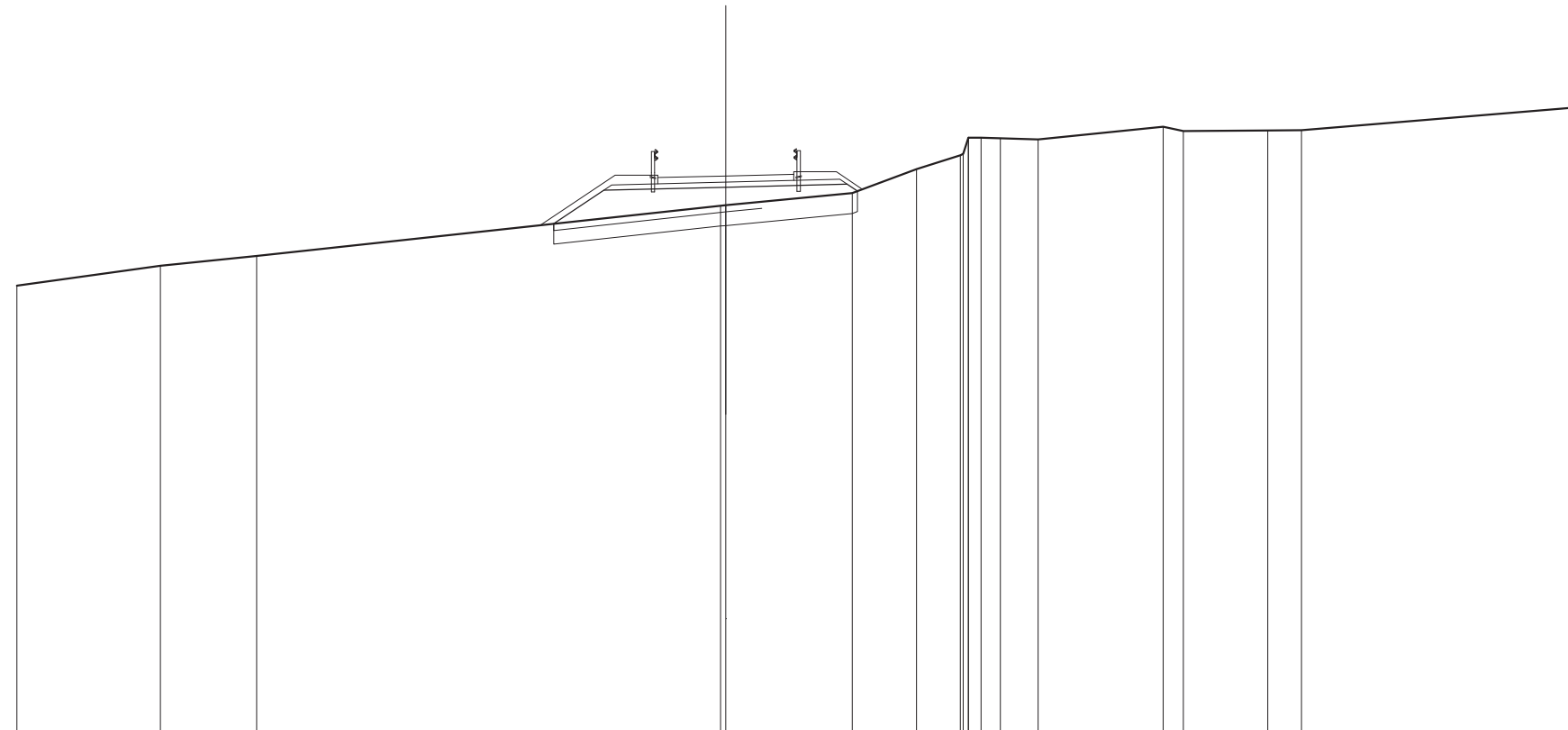

QUOTE TERRENO		468,325	468,909	468,196		470,672 470,667	471,042	471,743	472,153 472,191 472,663 472,663 472,664 472,651 472,616	472,986 472,857	472,876 472,883	473,555
DIST.PARZIALI TERRENO		4,215	2,832	13,629		3,715	1,890	1,290	0,570 1,106	3,672	0,686 2,479	0,686 8,079
QUOTE PROGETTO					470,141 471,125	471,214	471,303 471,100					
DIST.PARZIALI PROGETTO					1,474	3,584	3,567					
QUOTE PAVIMENTATO					471,314 471,494	471,544	471,414 471,594					
DIST.PARZIALI PAVIMENTATO					2,000	2,000						

<b>SCAVI E BONIFICHE</b>	
SCOTICO	10,160 m
BONIFICA	4,064 m <sup>2</sup>
<b>RILEVATI</b>	
RILEVATO	14,657 m <sup>2</sup>
TERRENO VEGETALE	7,721 m
<b>SOVRASTRUTTURA STRADALE</b>	
STRATI LEGATI	4,000 m
STRATO DI FONDAZIONE	1,039 m <sup>2</sup>

SEZIONE N.: 31  
 QT. PROGETTO: 470,218  
 DIST.PROG.: 500,000  
 DIST.PREC.: 20,000  
 DIST.SUCC.: 20,000

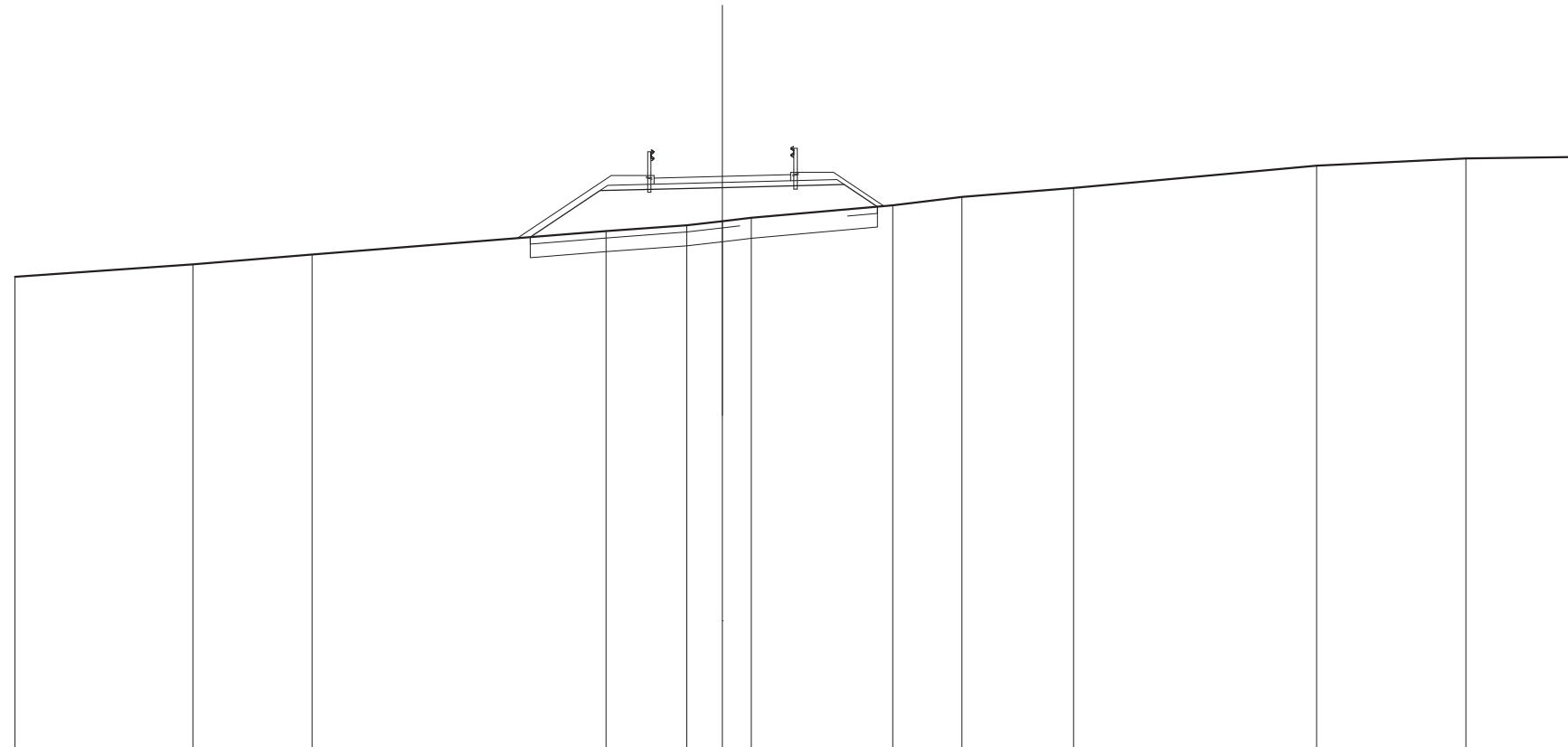

SCALA 1:200

QT.RIF. 453,483

QUOTE TERRENO		467,279		467,645		467,929		468,615	468,788	468,906	468,002		469,370	469,612	469,881		470,533	470,739	470,785
DIST.PARZIALI TERRENO			5,206		3,495		8,598		2,366	1,042	0,844		4,146	2,023	3,263		7,115	4,369	3,240
QUOTE PROGETTO								468,439	468,798		468,888		468,977	468,330					
DIST.PARZIALI PROGETTO								2,039	3,584		3,567		0,970						
QUOTE PAVIMENTATO									469,988	470,168	470,218		470,088	470,268					
DIST.PARZIALI PAVIMENTATO										2,000	2,000								





<b>SCAVI E BONIFICHE</b>	
STERRO	0,136 m <sup>2</sup>
SCOTICO	2,667 m
BONIFICA	2,896 m <sup>2</sup>
<b>RILEVATI</b>	
RILEVATO	4,268 m <sup>2</sup>
TERRENO VEGETALE	4,167 m
<b>SOVRASTRUTTURA STRADALE</b>	
STRATI LEGATI	4,000 m
STRATO DI FONDAZIONE	1,039 m <sup>2</sup>

SEZIONE N.: 33  
 QT. PROGETTO: 466,328  
 DIST.PROG.: 547,115  
 DIST.PREC.: 27,115  
 DIST.SUCC.: 7,707

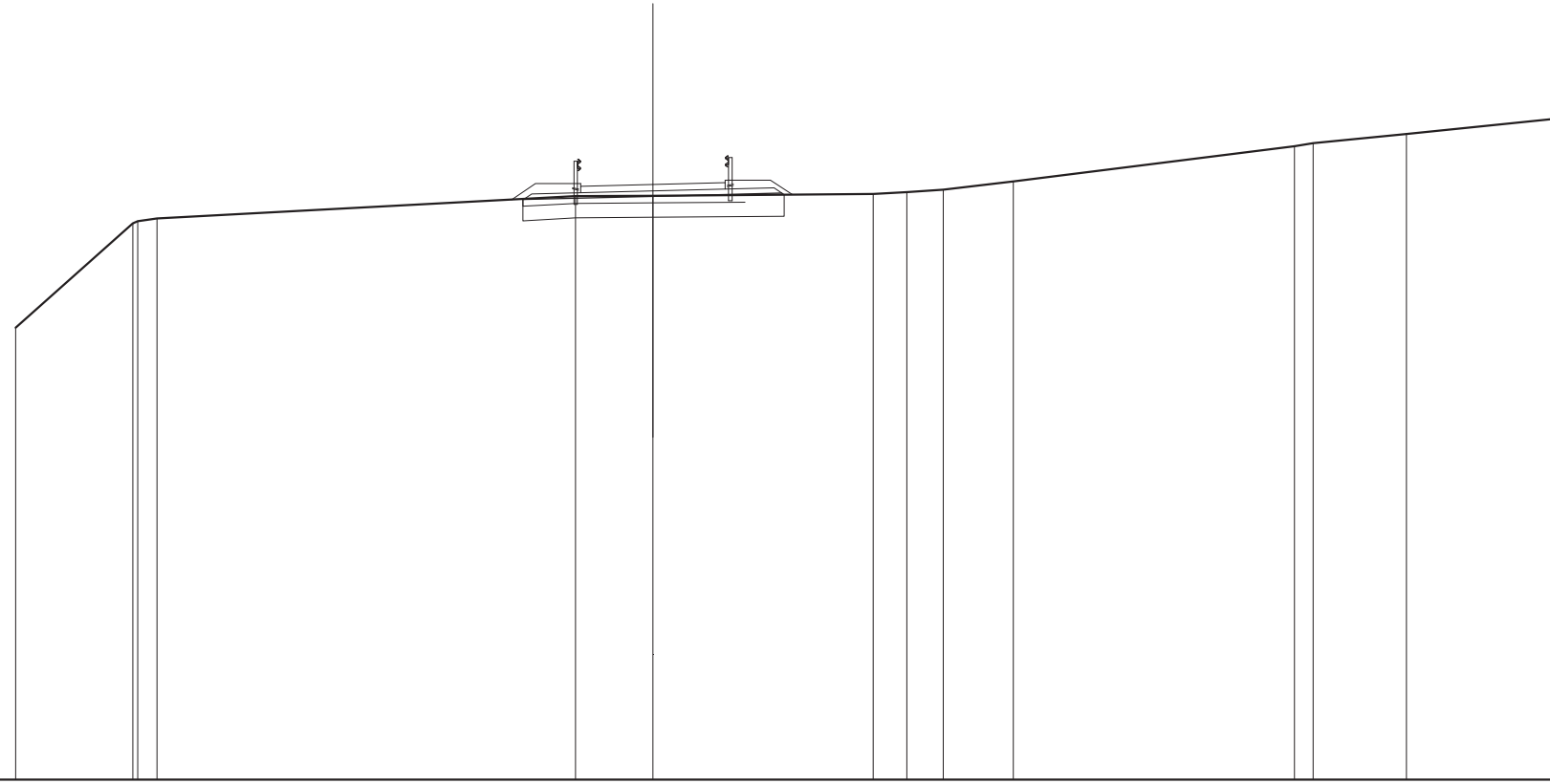

SCALA 1:200

QT.RIF. 449,855

QUOTE TERRENO	462,365	465,252 465,312 465,362	466,000	466,015	466,060	466,115	466,179	466,412	467,365 467,471	467,721	468,146	
DIST.PARZIALI TERRENO	3,242	0,551	11,583	2,147	6,095	0,828	1,009	1,938	7,783	0,519	2,579	4,148
QUOTE PROGETTO			465,922 465,908	465,988	466,087 466,042							
DIST.PARZIALI PROGETTO			3,584	3,567								
QUOTE PAVIMENTATO			466,098 466,278	466,328	466,198 466,378							
DIST.PARZIALI PAVIMENTATO			2,000	2,000								

<b>SCAVI E BONIFICHE</b>	
STERRO	2,067 m <sup>2</sup>
SCOTICO	3,971 m
BONIFICA	2,002 m <sup>2</sup>
<b>RILEVATI</b>	
RILEVATO	3,692 m <sup>2</sup>
TERRENO VEGETALE	4,350 m
<b>SOVRASTRUTTURA STRADALE</b>	
STRATI LEGATI	4,871 m
STRATO DI FONDAZIONE	0,951 m <sup>2</sup>

SEZIONE N.: 34  
 QT. PROGETTO: 465,473  
 DIST.PROG.: 554,822  
 DIST.PREC.: 7,707  
 DIST.SUCC.: 7,707

SCALA 1:200

QT.RIF. 449,138

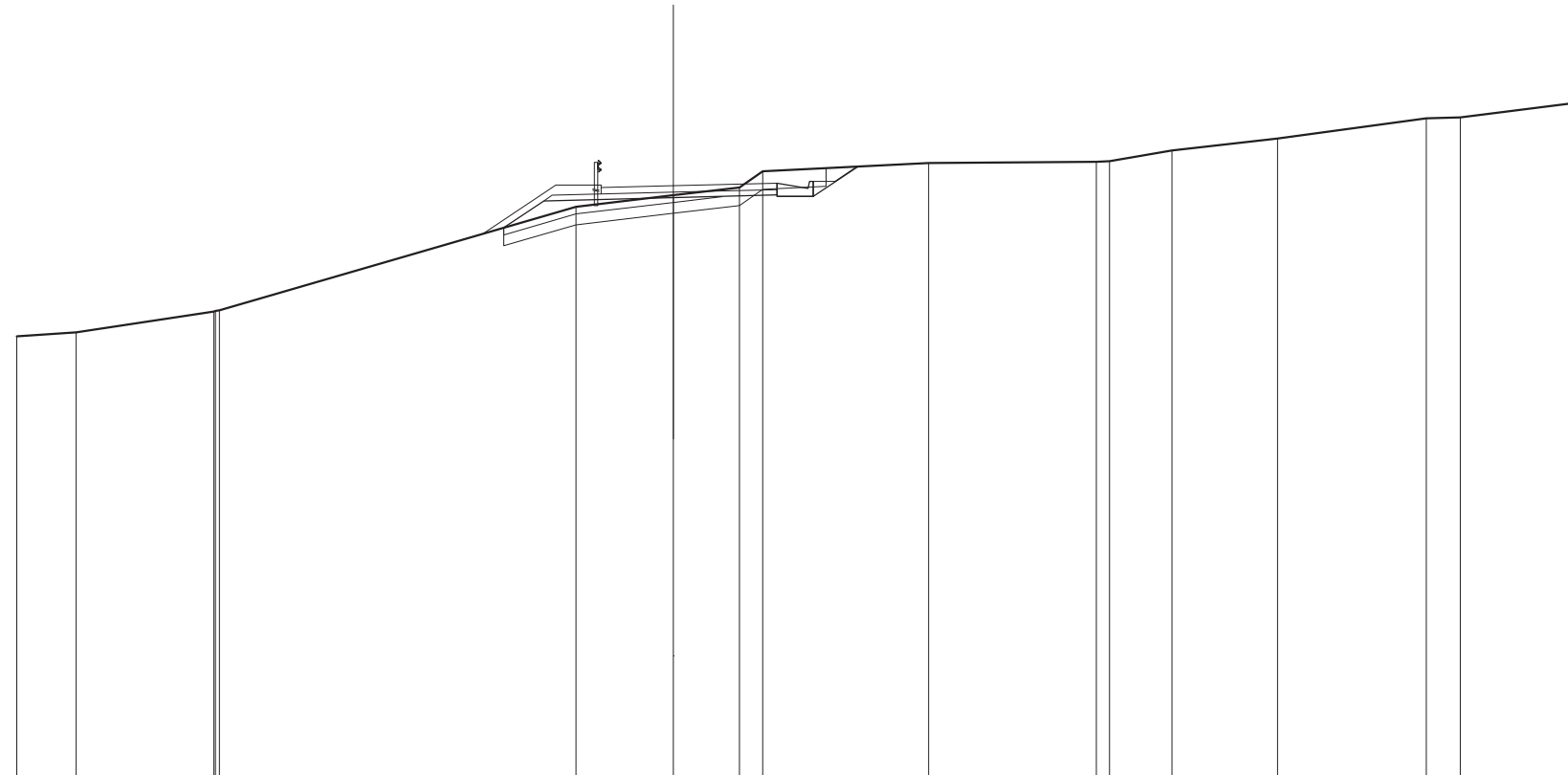

QUOTE TERRENO	461,308	461,420	461,989 462,008 462,027	464,882	465,210	465,428 465,867	466,087	466,131 466,150	466,449	466,780	467,331 467,362	467,788
DIST.PARZIALI TERRENO	1,644	3,815	9,866	2,696	1,831	0,643	4,584	4,643	1,727	2,922	4,117	0,846 3,226
QUOTE PROGETTO				464,312 465,053	465,143	465,174 465,214 465,544	465,174 465,174 465,584 465,989					
DIST.PARZIALI PROGETTO				1,112	3,584	2,871	0,880 1,288					
QUOTE PAVIMENTATO				465,243 465,423	465,473	465,364 465,544						
DIST.PARZIALI PAVIMENTATO				2,000	2,871							



