

SEZIONE A-A
Scala 1:50

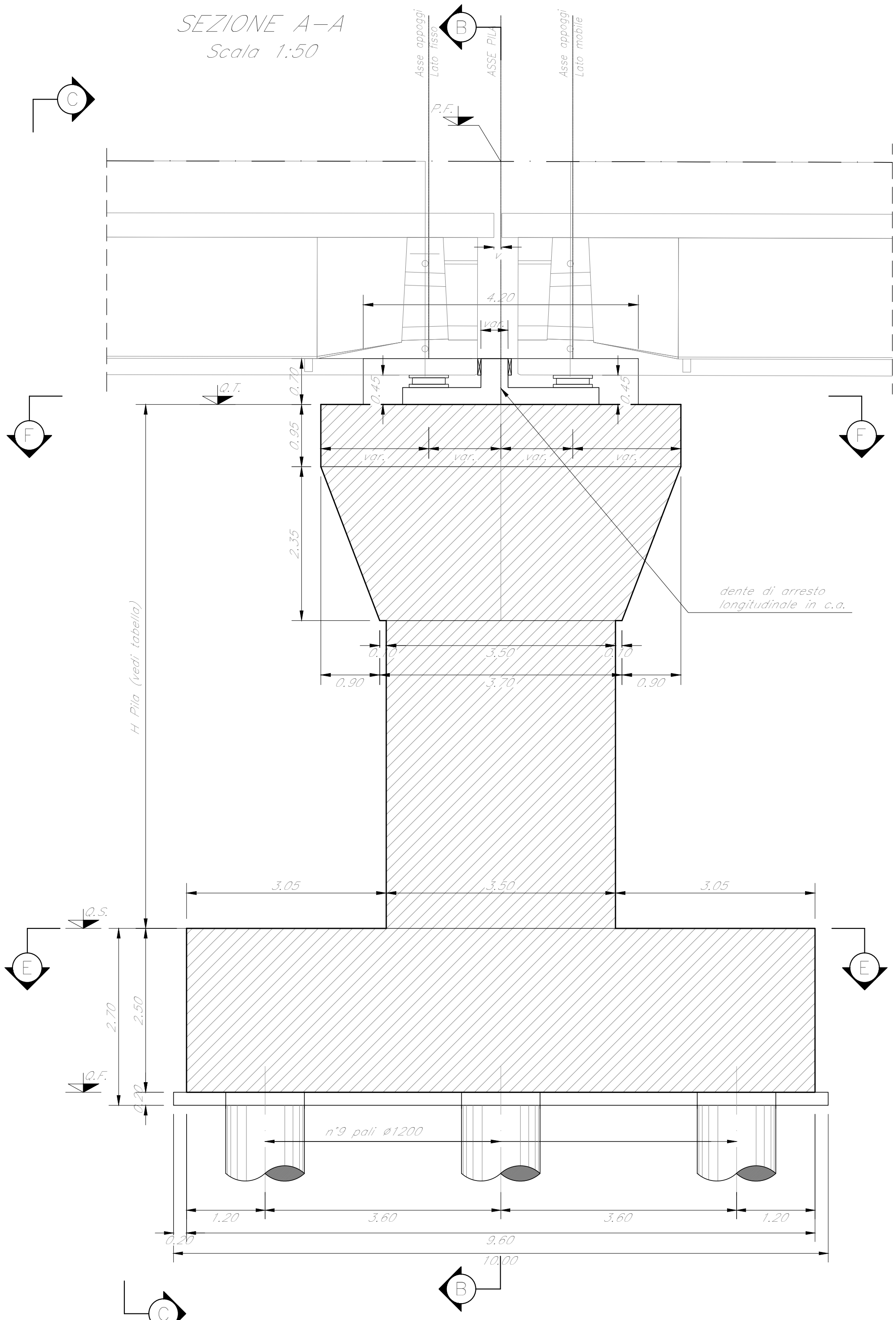

SEZIONE B-B
Scala 1:50

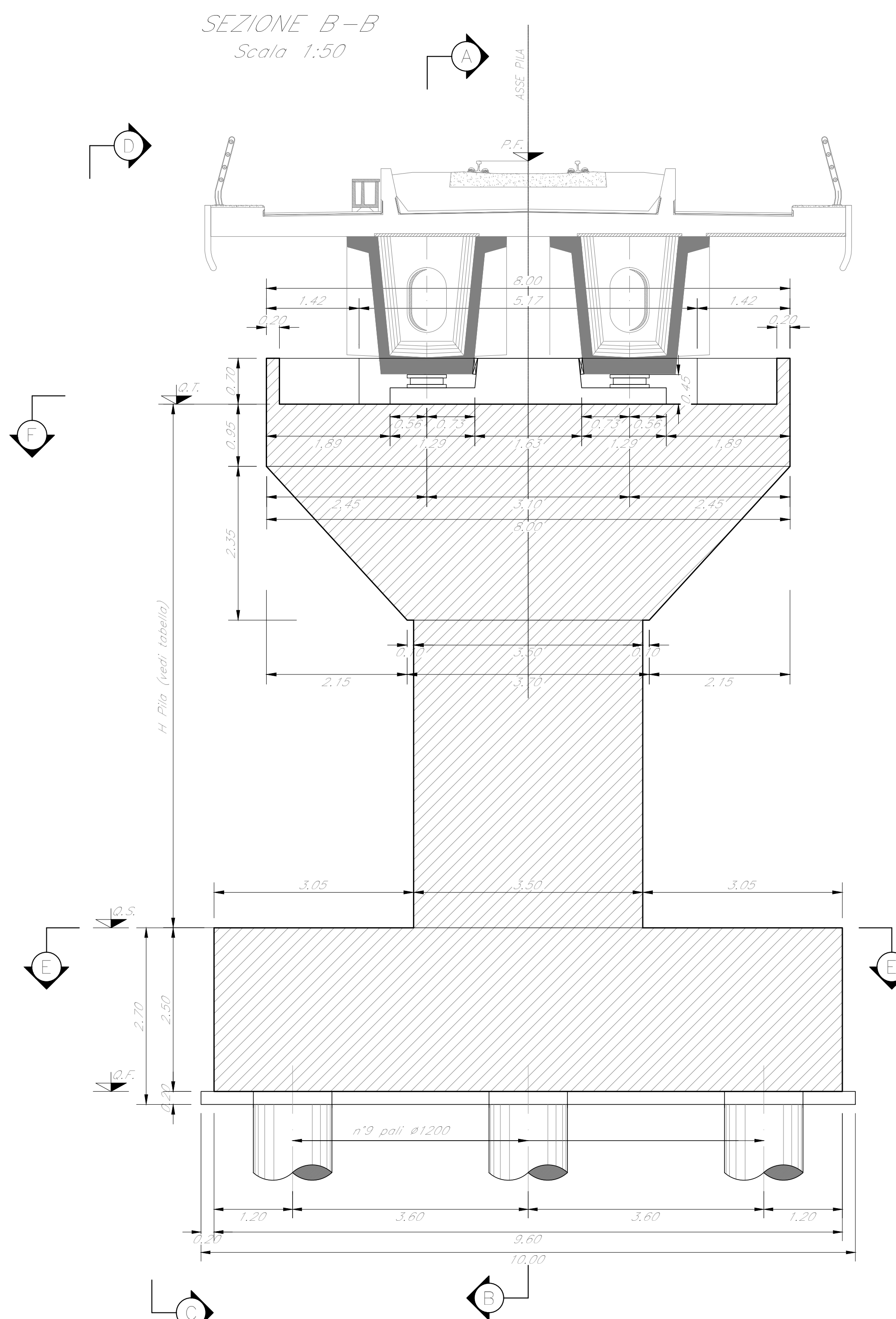

VISTA C-C
Scala 1:50

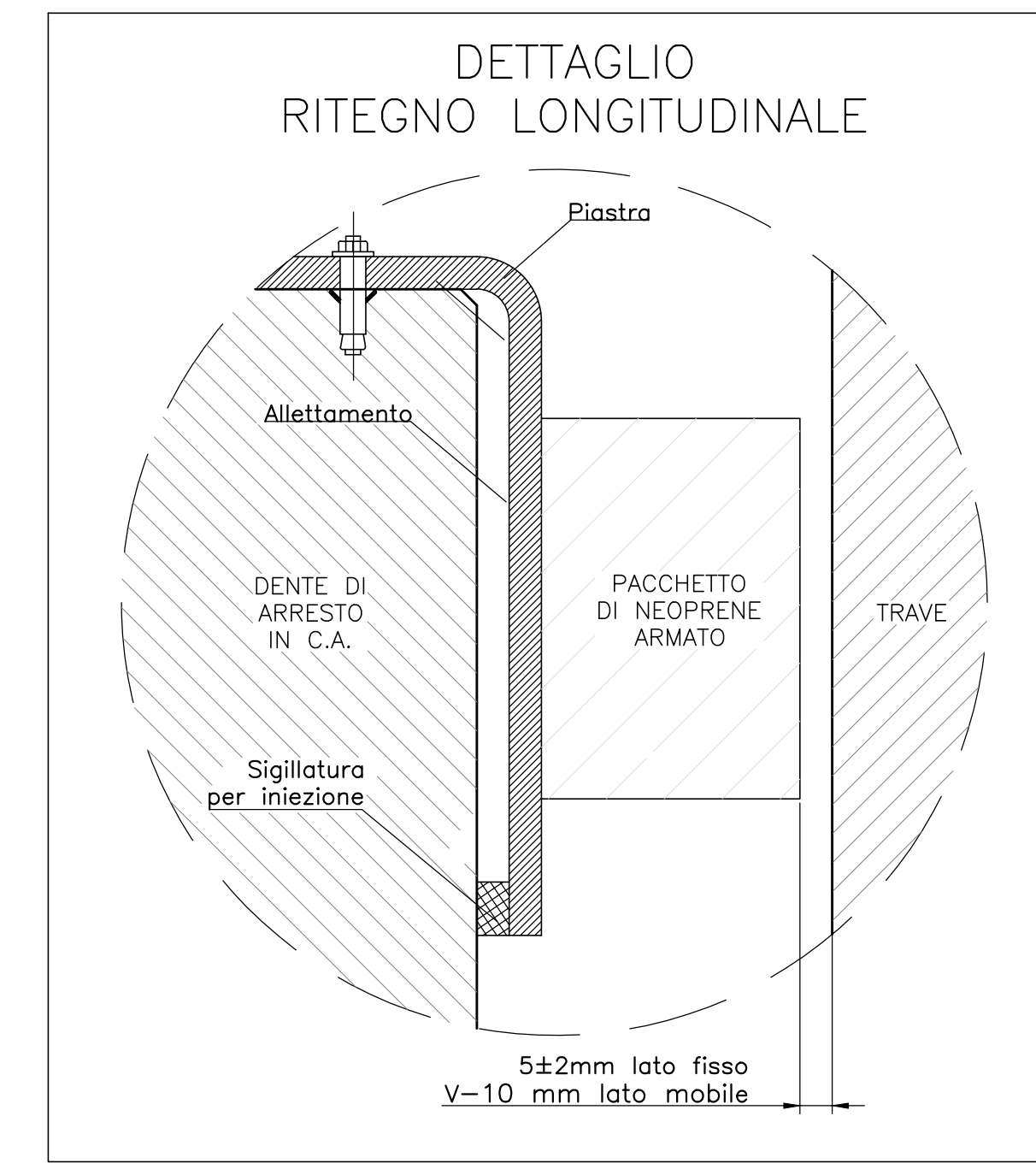
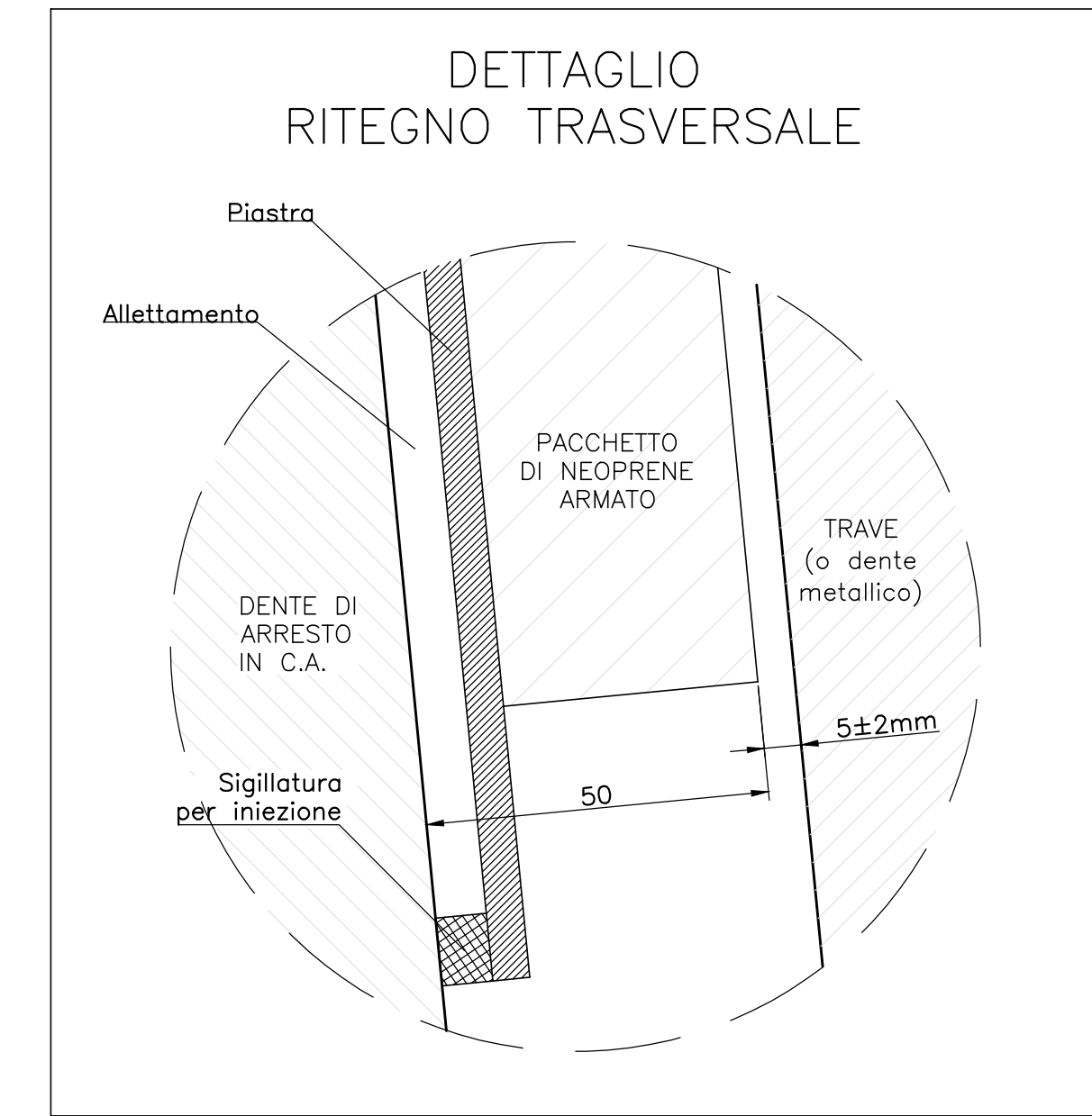
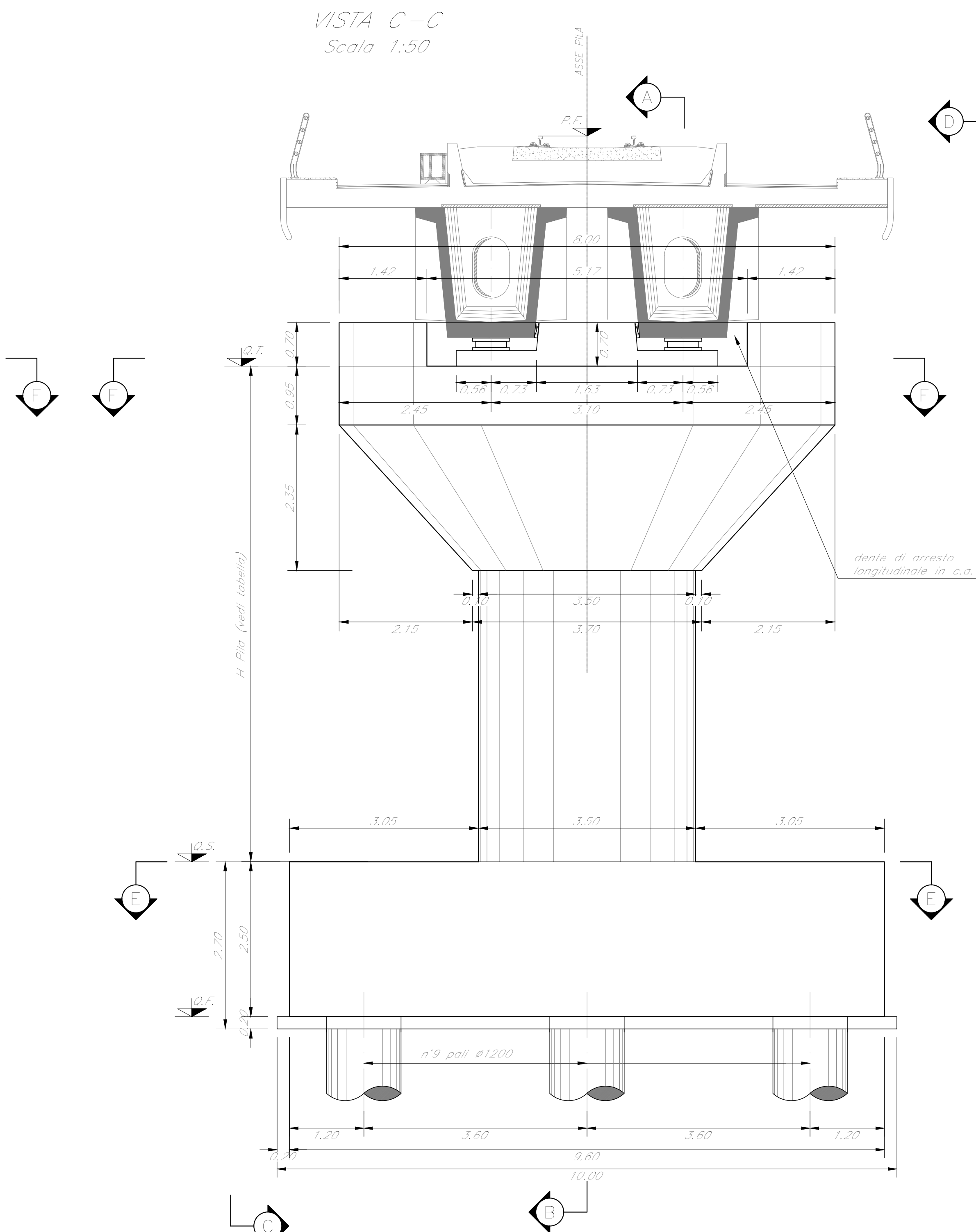

VISTA D-D
Scala 1:50

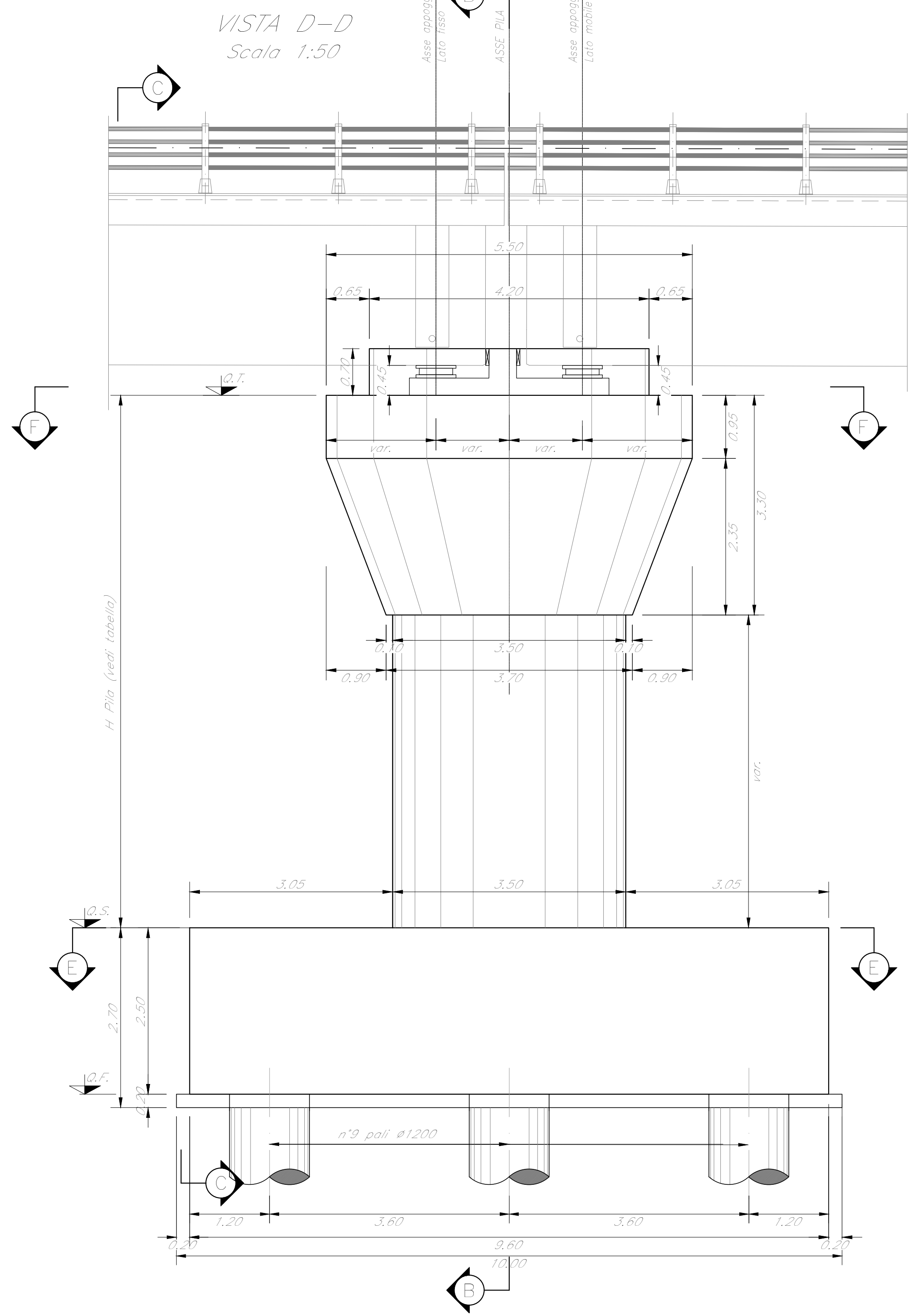

SEZIONE E-E
Scala 1:50



TABELLA PILE (m)

Pila	P.F.	Q.T.	Q.S.	Q.F.	H. Pila	H. Fusto	L. Pila
P6	+358,60	+354,03	+347,13	+344,63	7,80	4,50	24,00
P7	+358,48	+354,77	+346,47	+343,97	8,30	5,00	24,00
P8	+358,32	+354,61	+346,31	+343,81	6,80	5,00	24,00

NOTE:
1) Per la tabella materiali, note generali e incidenze fare riferimento al documento 753130009711000001 - Materiali e prescrizioni generali.
2) Varco v = 90 mm

COMMITTENTE: **RFI** RETE FERROVIARIA ITALIANA GRUPPO FERROVIE DELLO STATO ITALIANE

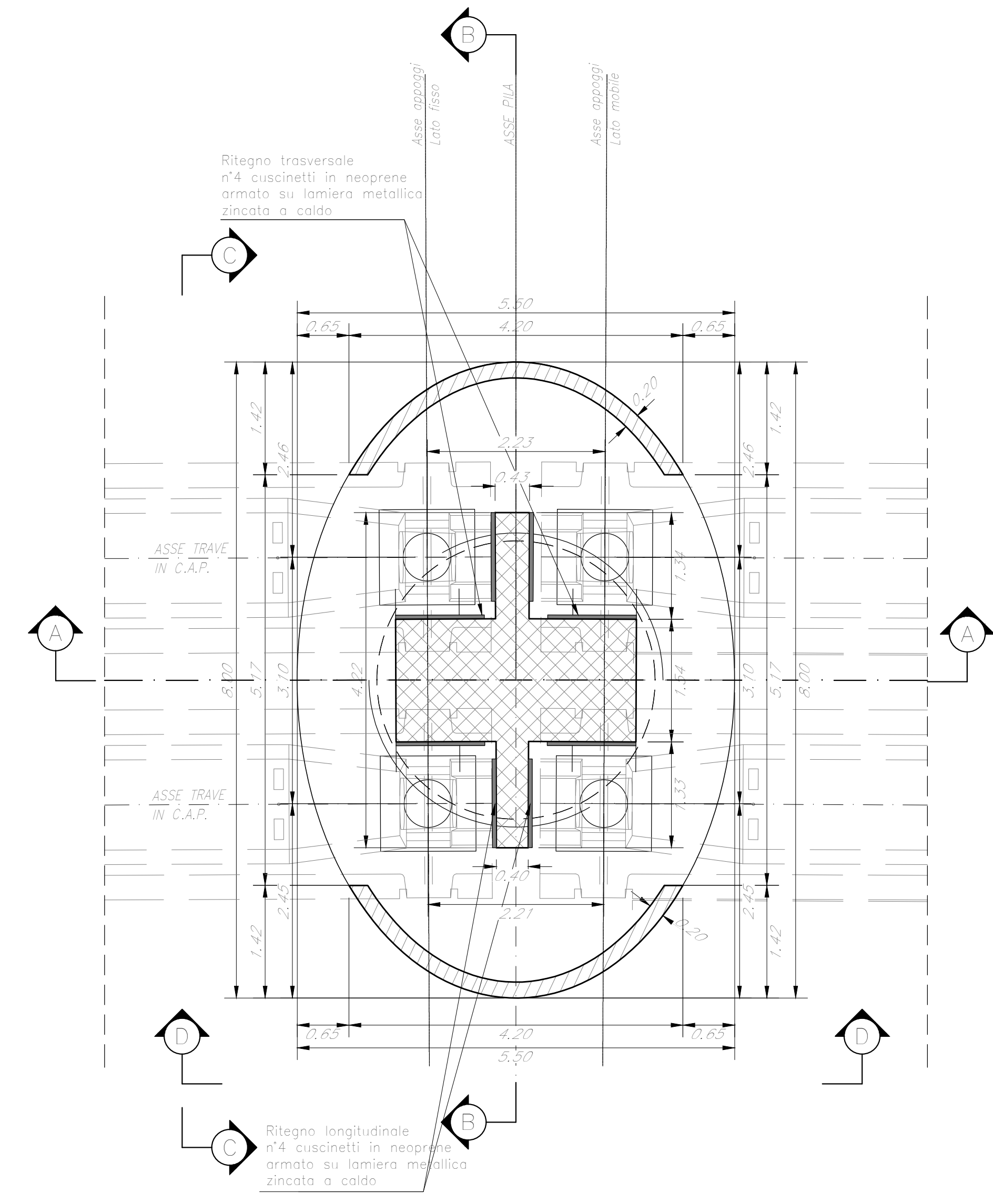
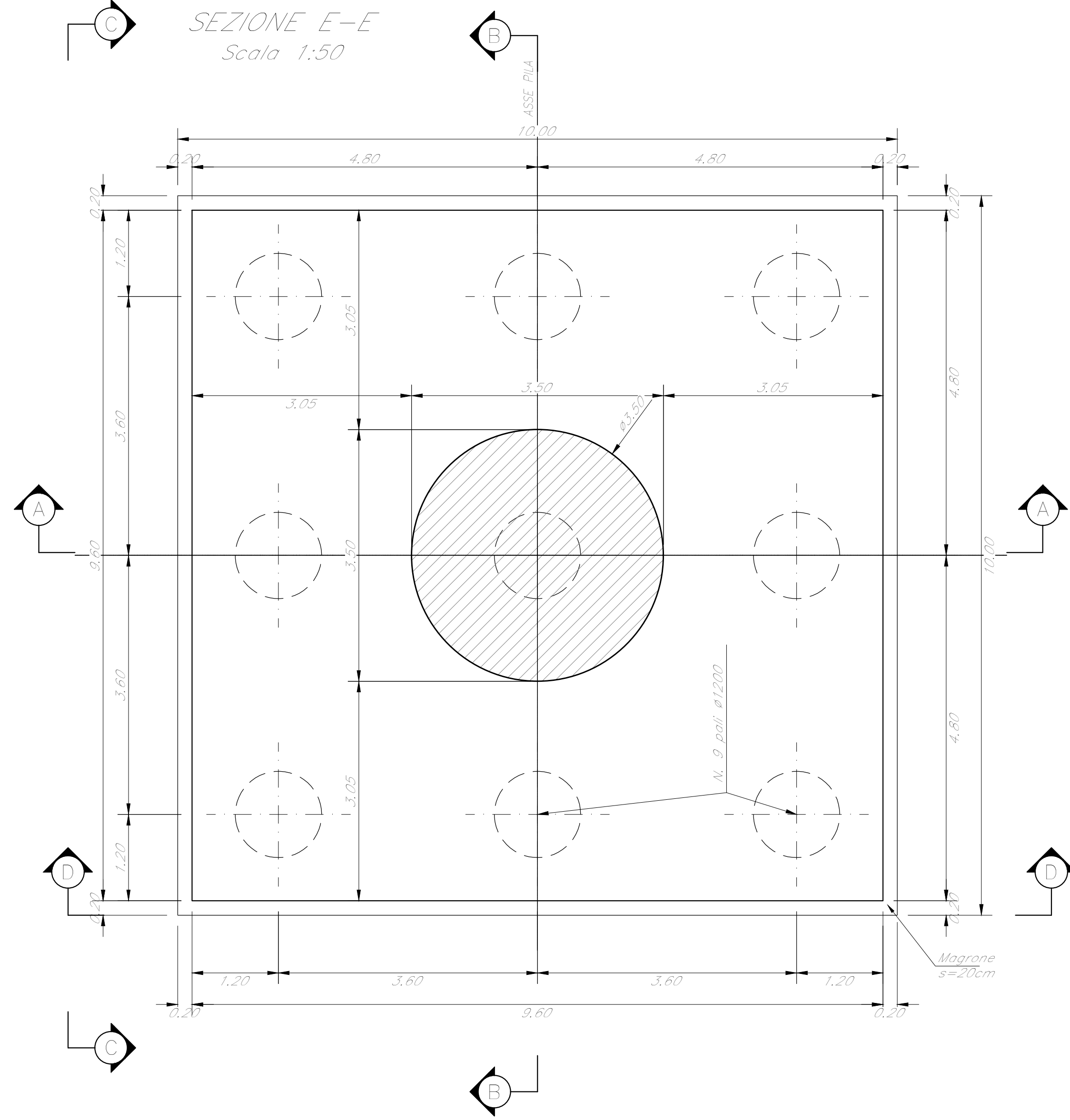
PROGETTAZIONE: **ITALFER** GRUPPO FERROVIE DELLO STATO ITALIANE

DIRETTRICE FERROVIARIA MESSINA - CATANIA - PALERMO
NUOVO COLLEGAMENTO PALERMO - CATANIA

U.O. OPERE CIVILI E GESTIONE DELLE VARIANTI

PROGETTO DEFINITIVO

TRATTA LERCARA DIR. - CALTANISSETTA XIRBI (LOTTO 3)

V112 - Viadotto ferroviario, Singolo Binario
Carpenteria Pila P6 - Pila P7 - Pila P8

SCALA:

Rev.	Descrizione	Redatto	Data	Verificato	Data	Approvato	Data	Autorizzato Data
A	Emissione esecutiva	G. Girardi	Gen 2020	A. Ferraro	Gen 2020	A. Santoro	Gen 2020	A. Viscio Mag 2020
B	Emissione esecutiva	G. Girardi	Feb 2020	A. Ferraro	Feb 2020	A. Santoro	Feb 2020	
C	1° app a consegna CIL/FP	G. Girardi	Mag 2020	A. Ferraro	Mag 2020	A. Santoro	Mag 2020	

File:RS3T300096ZV1120504C.dwg