

SEZIONE A-A
Scala 1:50

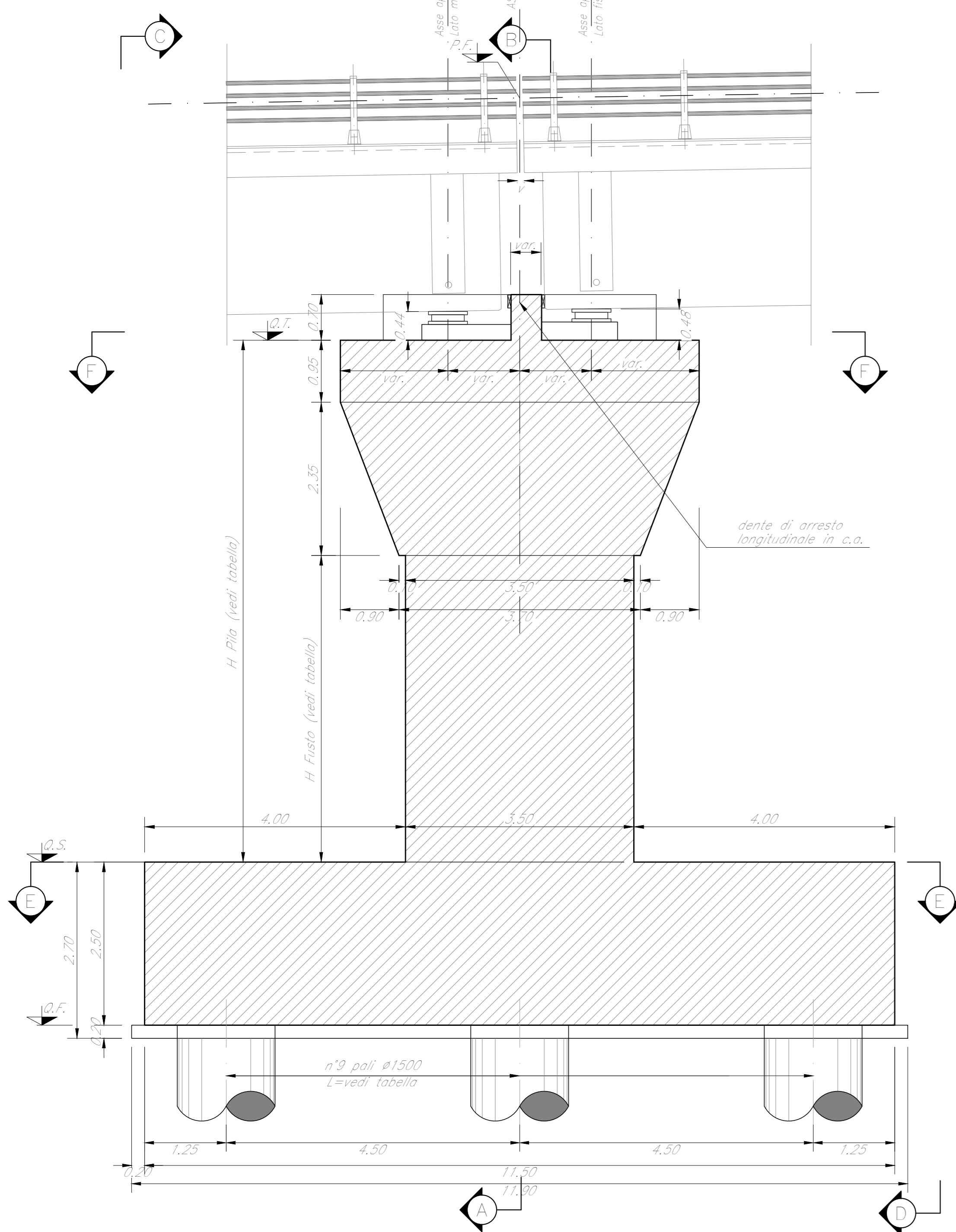

SEZIONE B-B
Scala 1:50

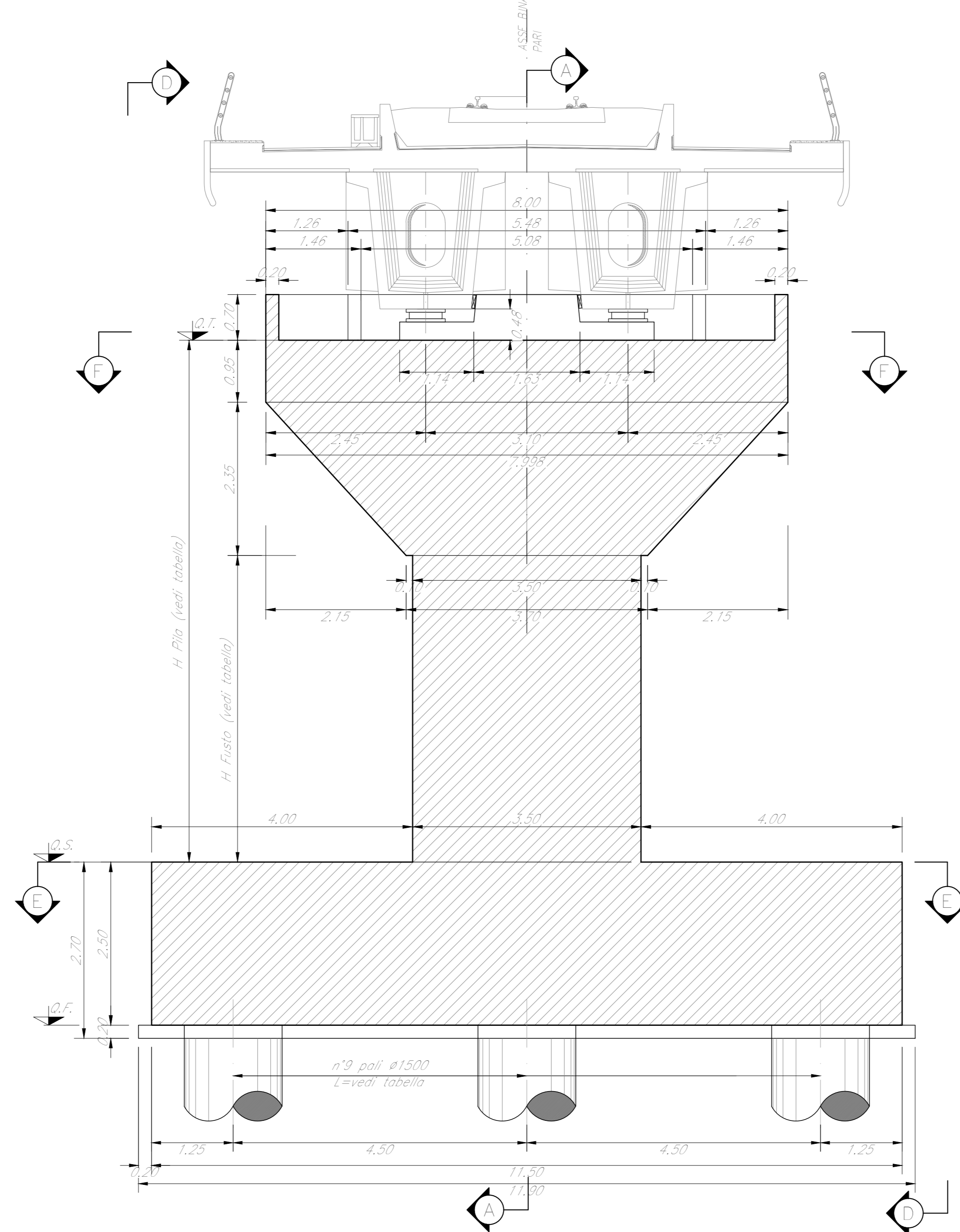

VISTA C-C
Scala 1:50

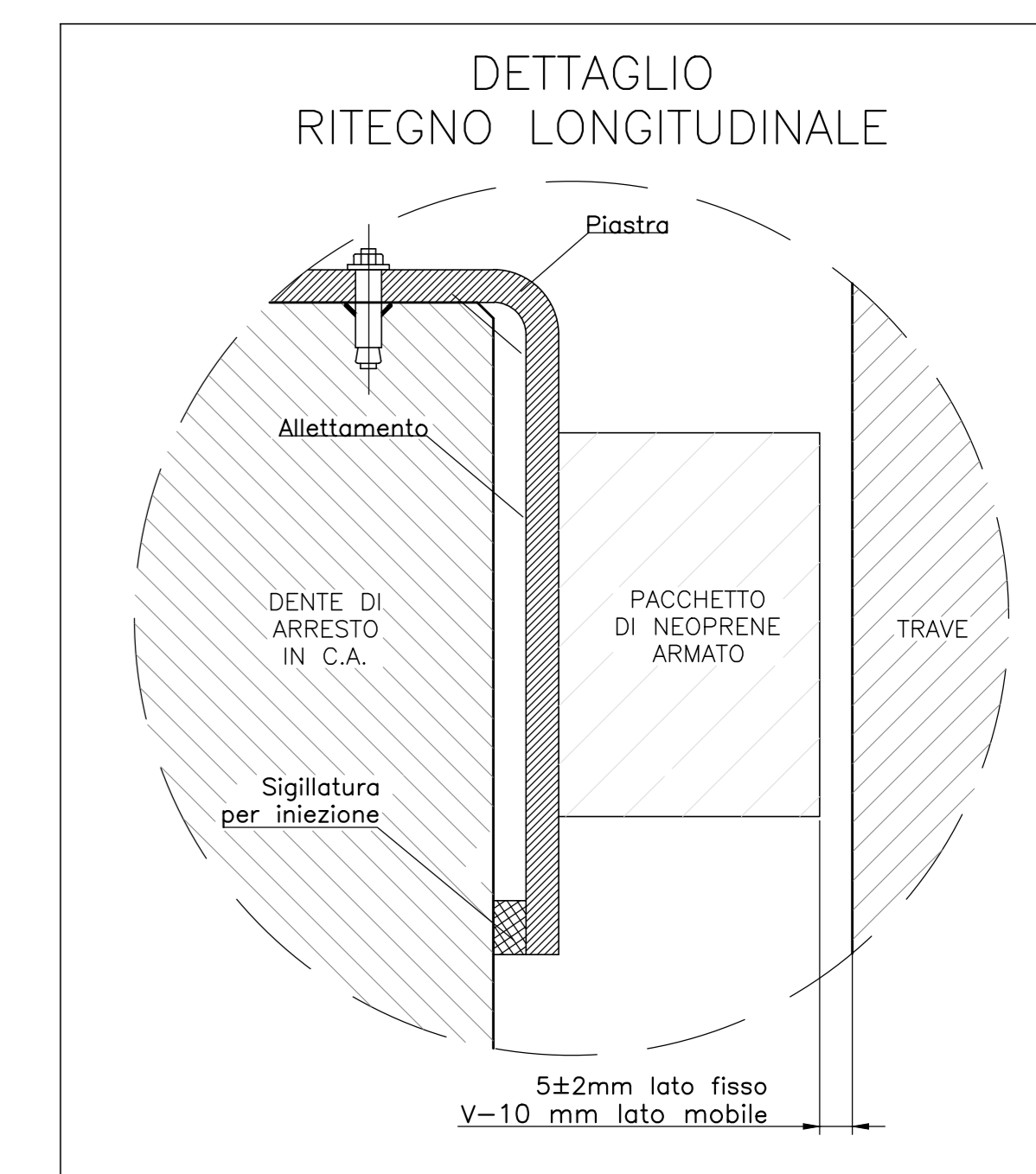
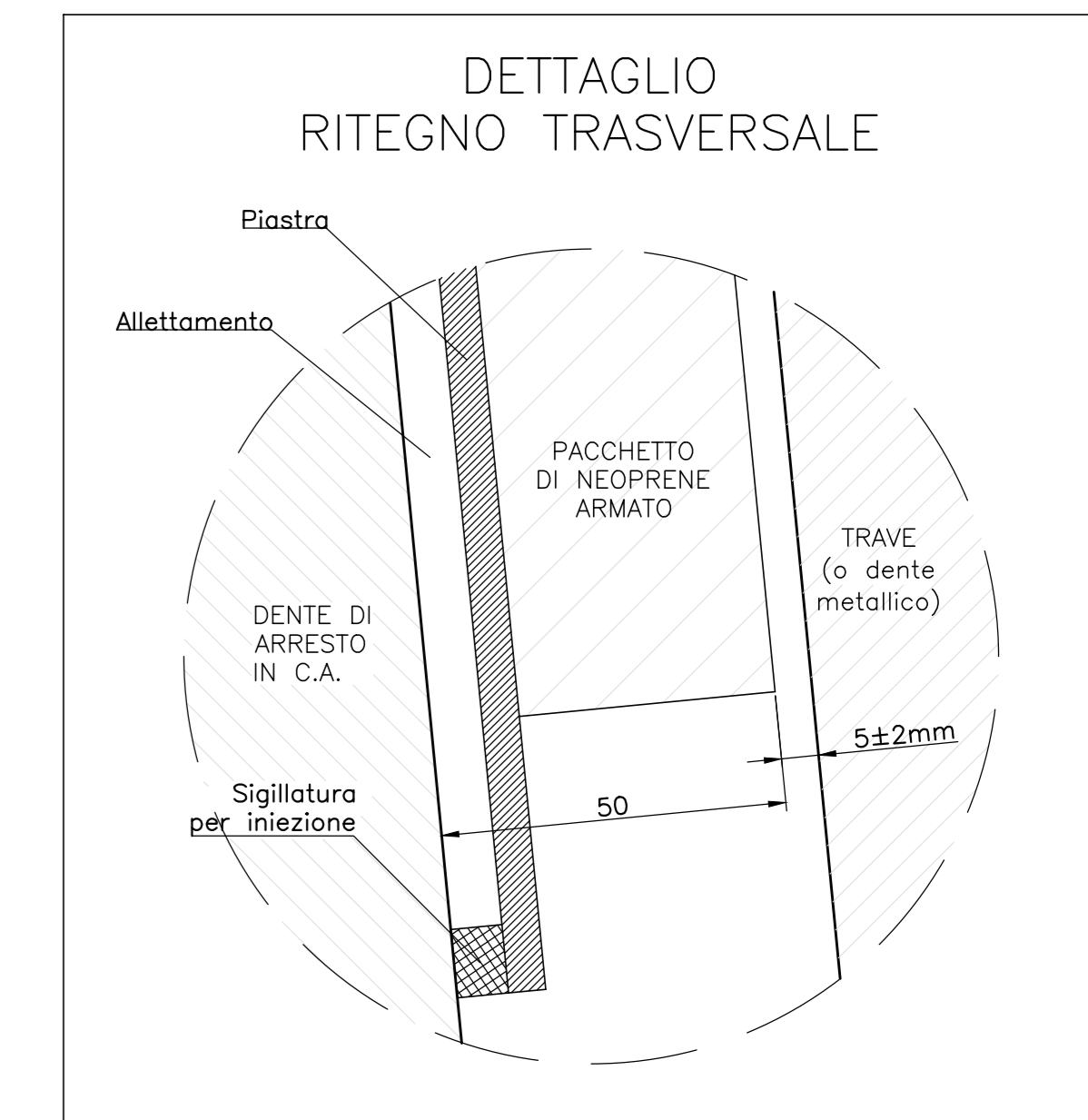
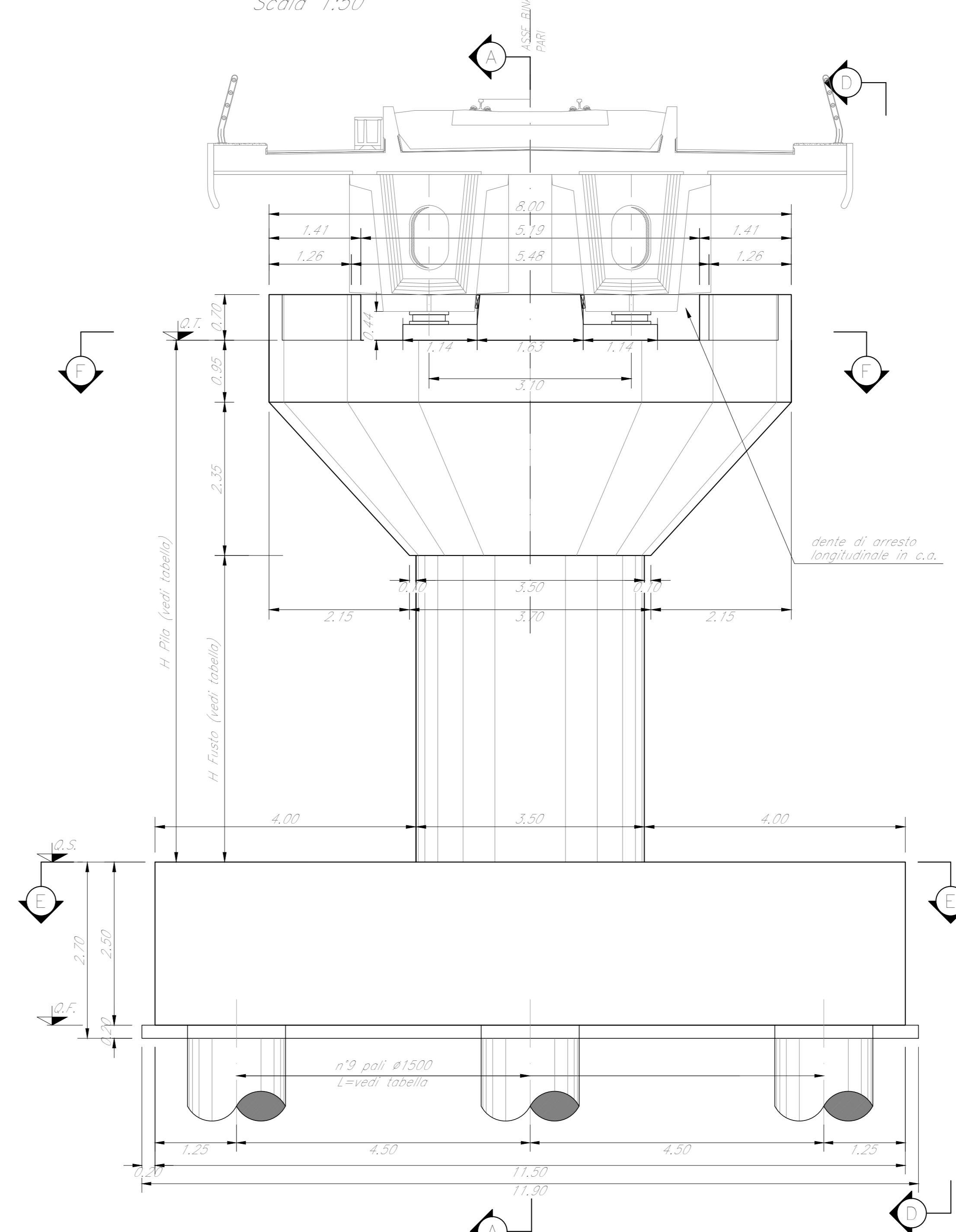

VISTA D-D
Scala 1:50

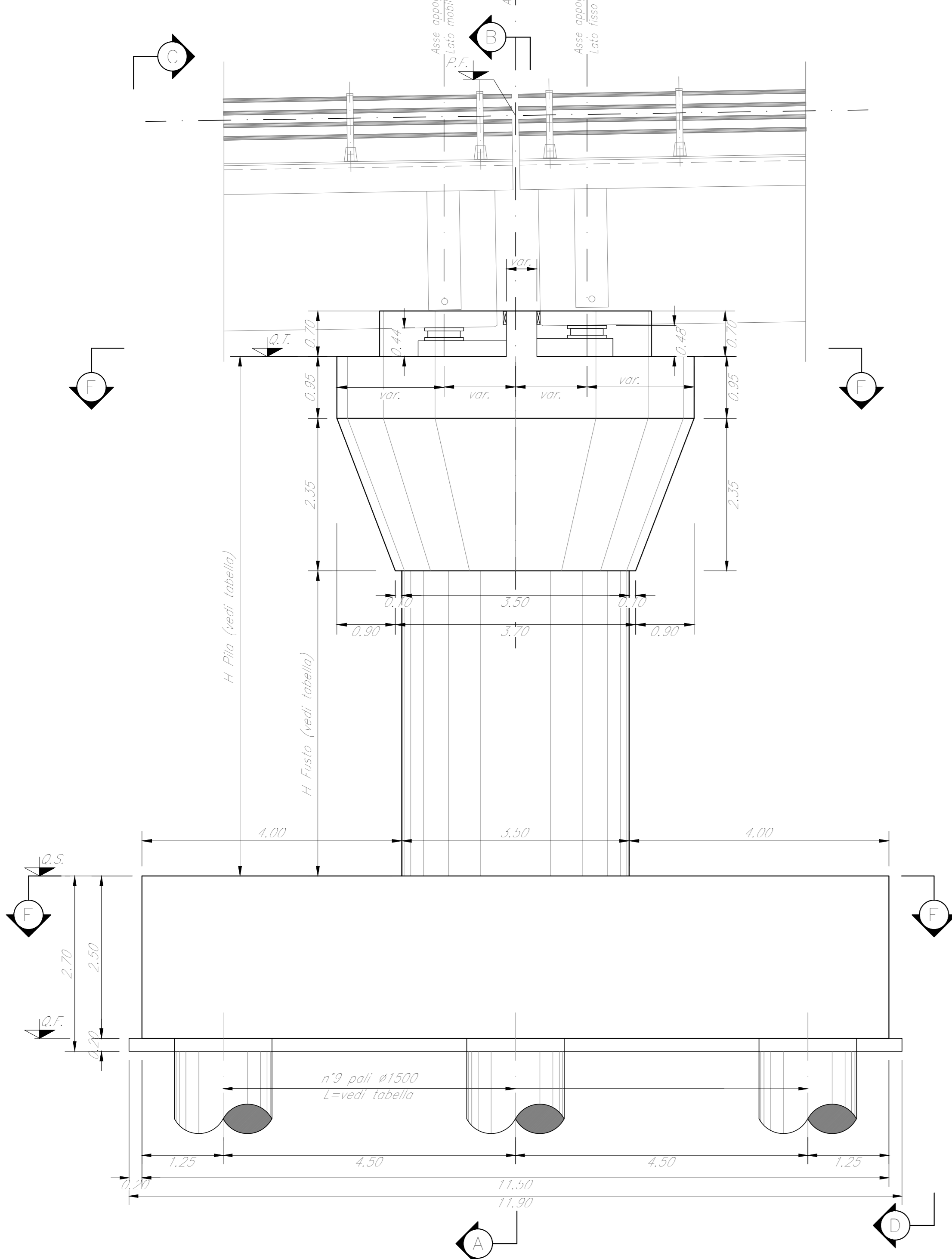

SEZIONE E-E
Scala 1:50

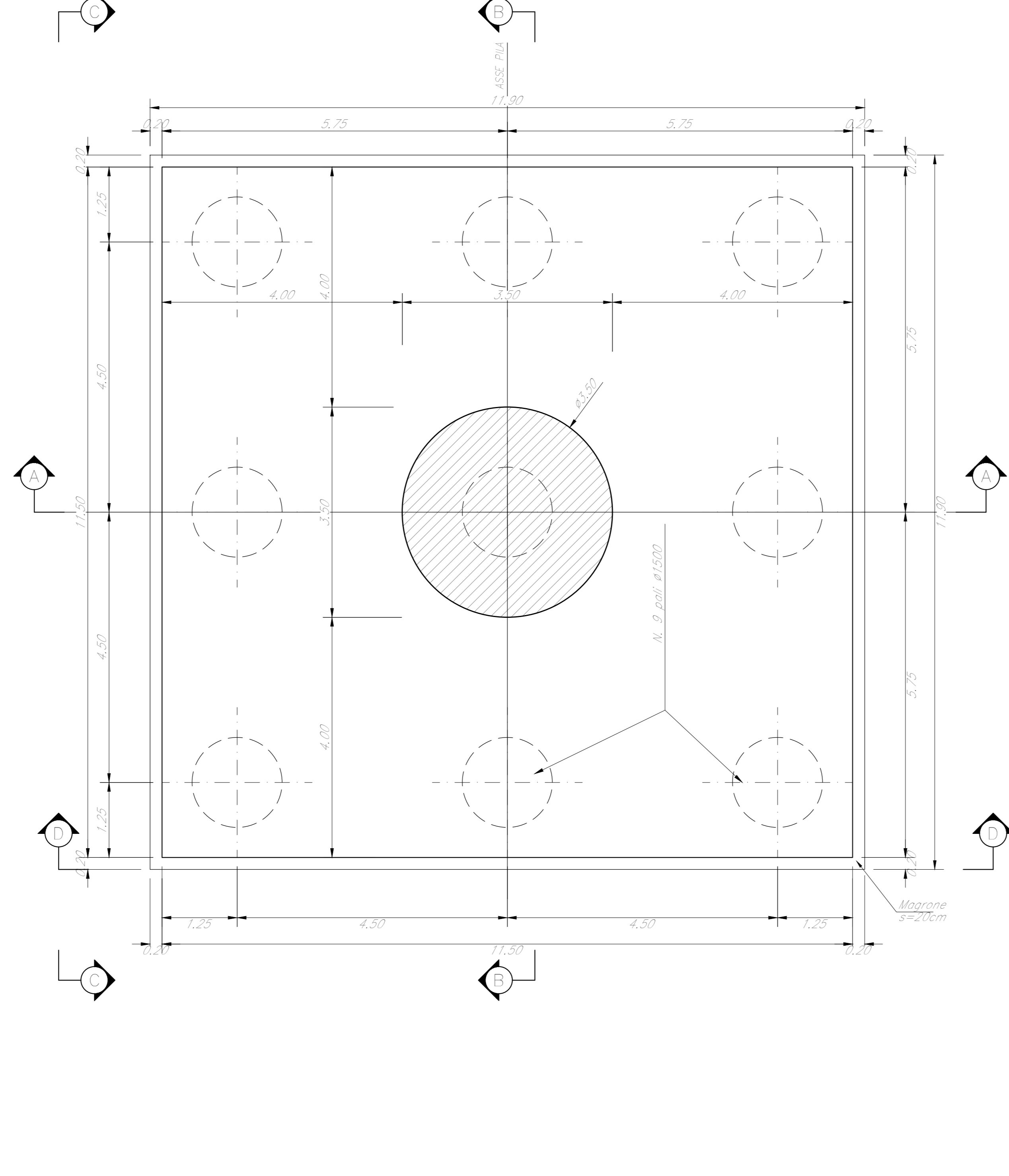

SEZIONE F-F
Scala 1:50



TABELLA PILE (m)

Pila	P.F.	Q.T.	Q.S.	Q.F.	H Fusto	H Pila	L Pila
P28	+335,42	+331,71	+313,92	+311,42	14,50	17,80	36,00
P29	+335,83	+332,12	+314,32	+311,82	14,50	17,80	36,00
P30	+336,23	+332,52	+314,72	+312,22	14,50	17,80	36,00

NOTE:
1) Per la tabella materiali, note generali e incidenze fare riferimento al documento RS3T30D09110000001 - Materiali e prescrizioni generali.
2) v = 90 mm

COMMITTEE: **RFI** RETE FERROVIARIA ITALIANA GRUPPO FERROVIE DELLO STATO ITALIANE

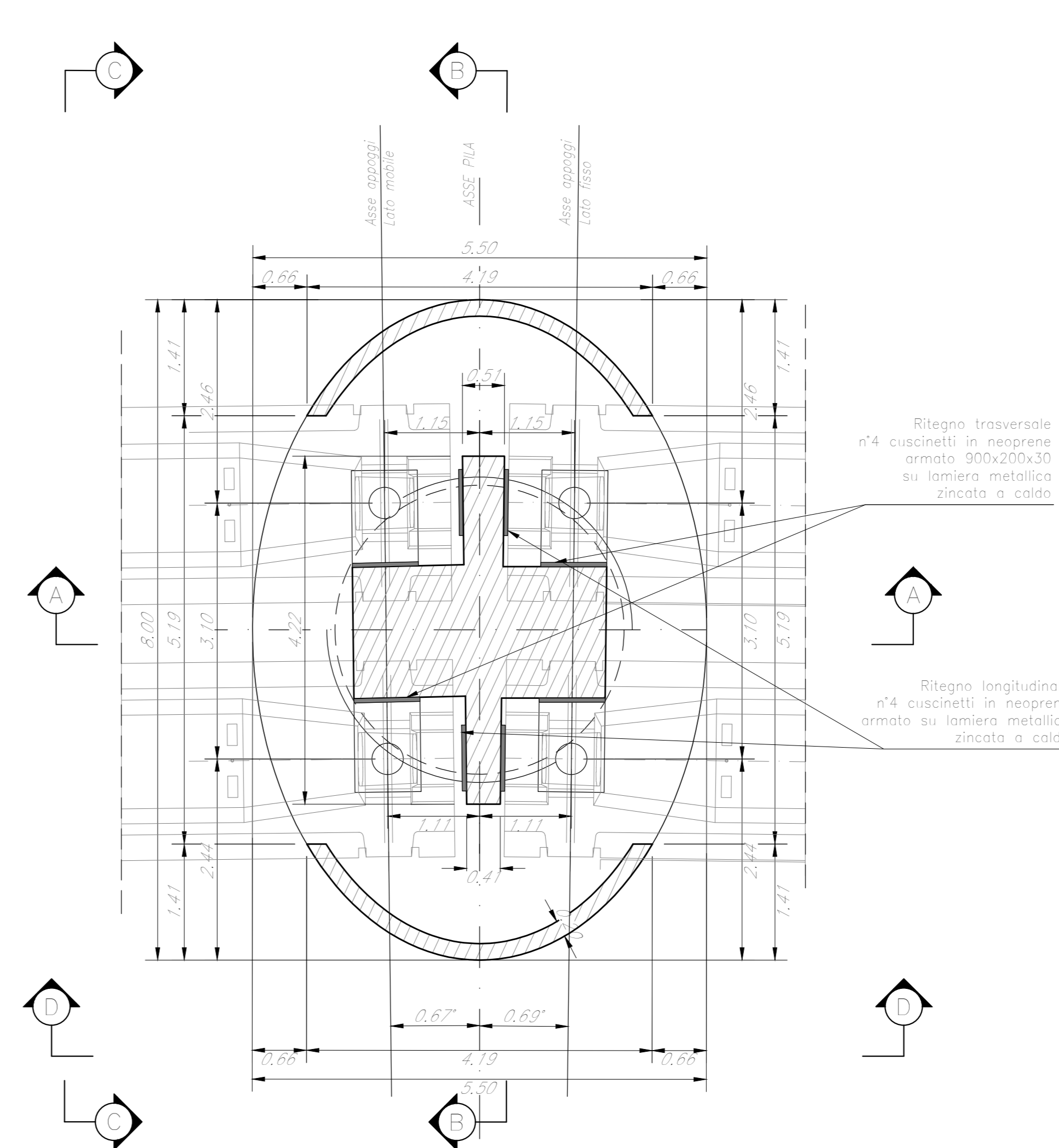
PROGETTAZIONE: **ITALFERR** GRUPPO FERROVIE DELLO STATO ITALIANE

DIRETTRICE FERROVIARIA MESSINA - CATANIA - PALERMO
NUOVO COLLEGAMENTO PALERMO - CATANIA

U.O. OPERE CIVILI E GESTIONE DELLE VARIANTI

PROGETTO DEFINITIVO

TRATTA LERCARA DIR. - CALTANISSETTA XIRBI (LOTTO 3)

V117 - Viadotto ferroviario, Singolo Binario
Carpenteria Pila P28 - Pila P29 - Pila P30

SCALA: **Varie**

Rev.	Descrizione	Redatto	Data	Verificato	Data	Approvato	Data	Autorizzato	Data
A	Emissione esecutiva	G. Giraldi	Gen 2020	A. Fedi	Gen 2020	A. Banca	Gen 2020	A. Vassù	Mag 2020
B	Emissione esecutiva	G. Giraldi	Feb 2020	A. Fedi	Feb 2020	A. Banca	Feb 2020		
C	1° app. a consegna CSU/PP	G. Giraldi	Mag 2020	A. Fedi	Mag 2020	A. Banca	Mag 2020		

File:RS3T30D09BZV1170524C.dwg