

SEZIONE A-A  
Scala 1:50

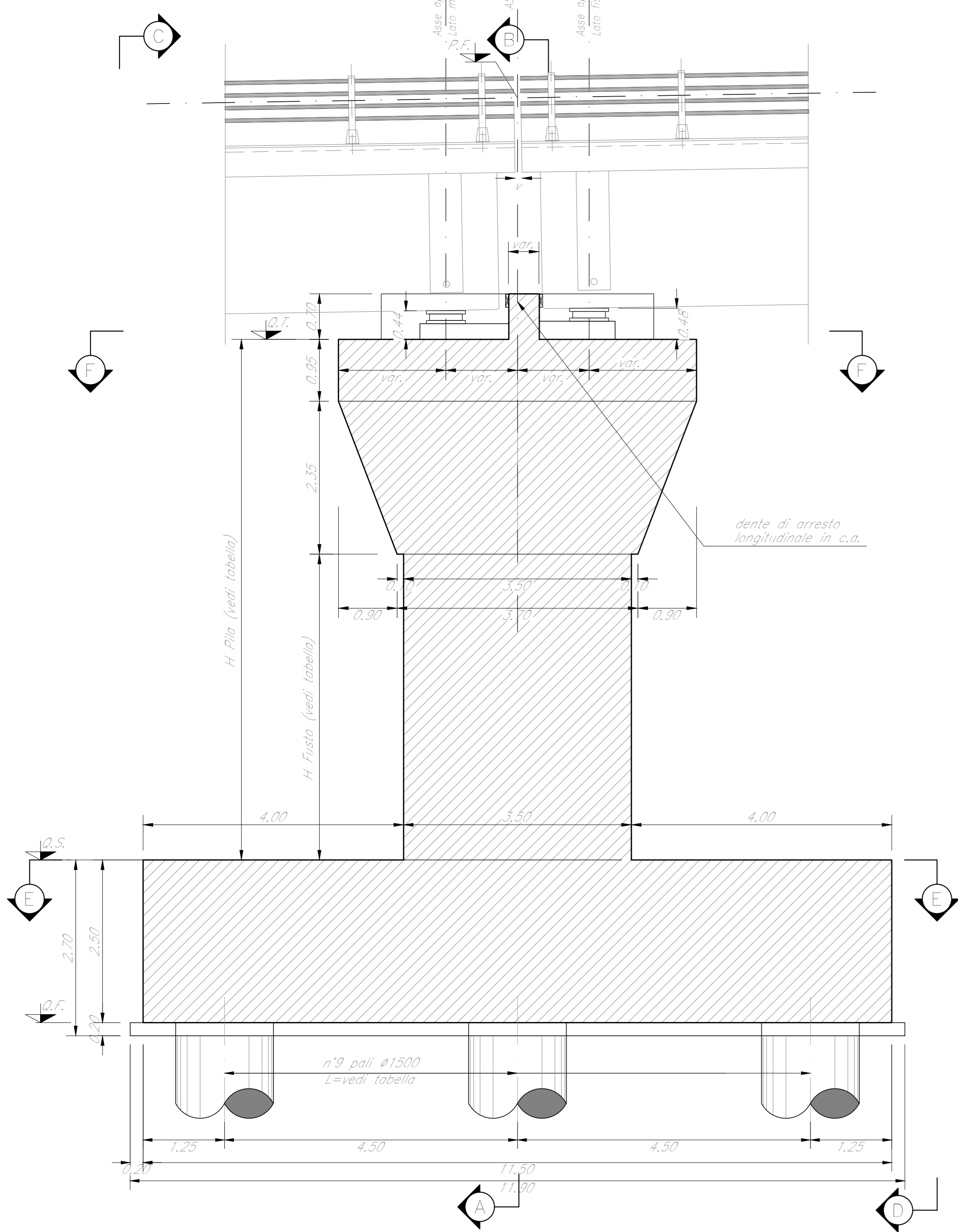

SEZIONE B-B  
Scala 1:50

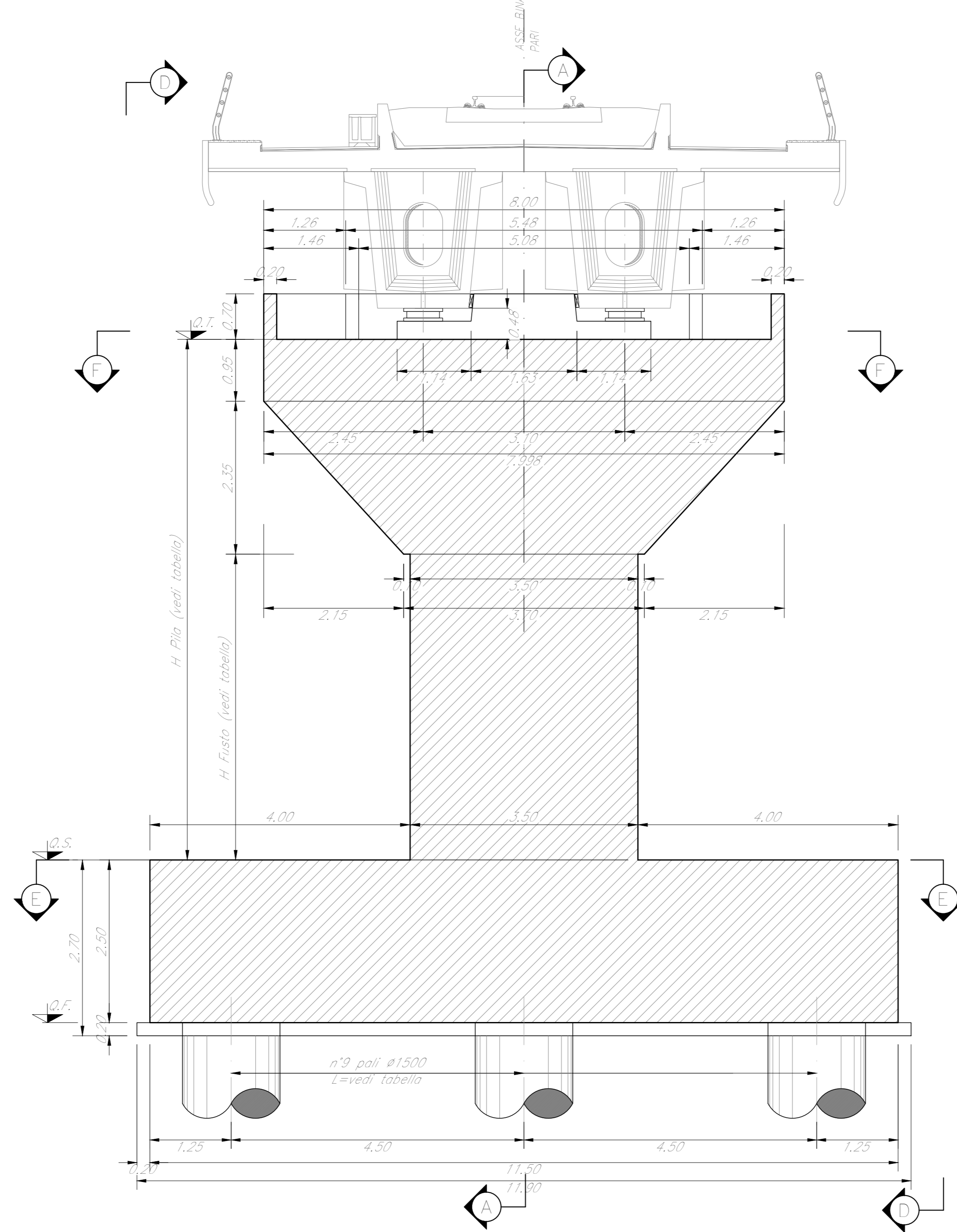

VISTA C-C  
Scala 1:50

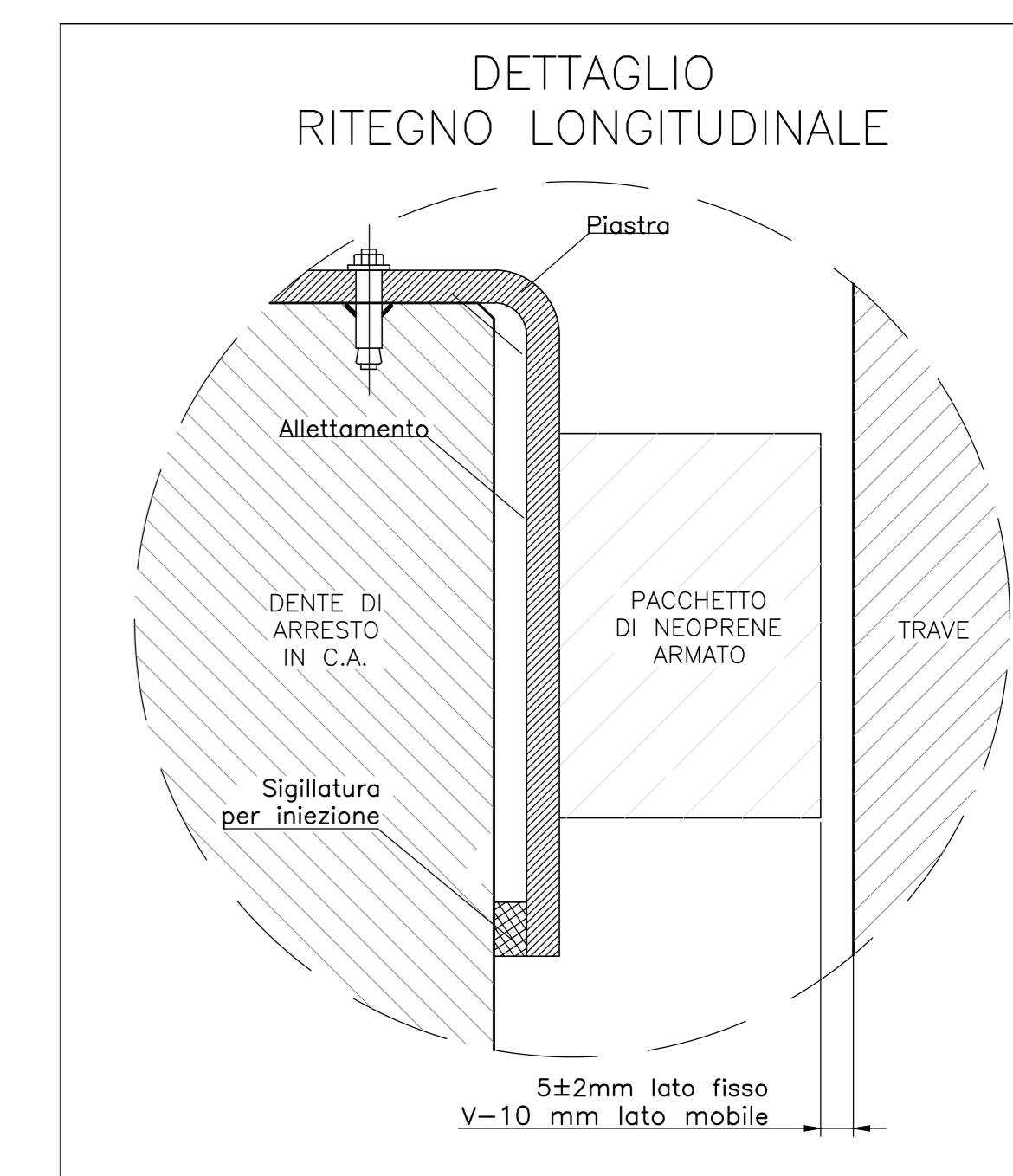
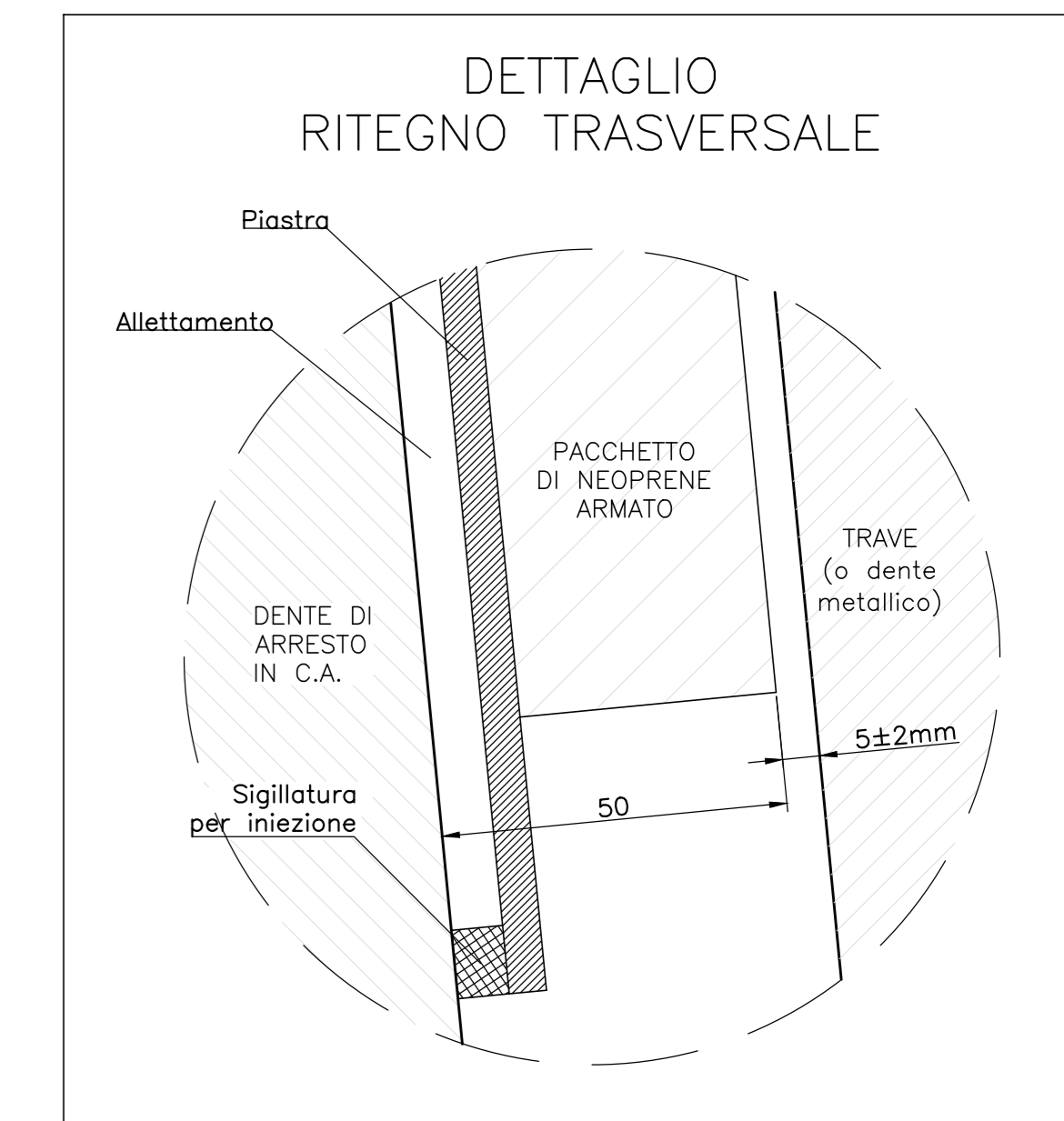
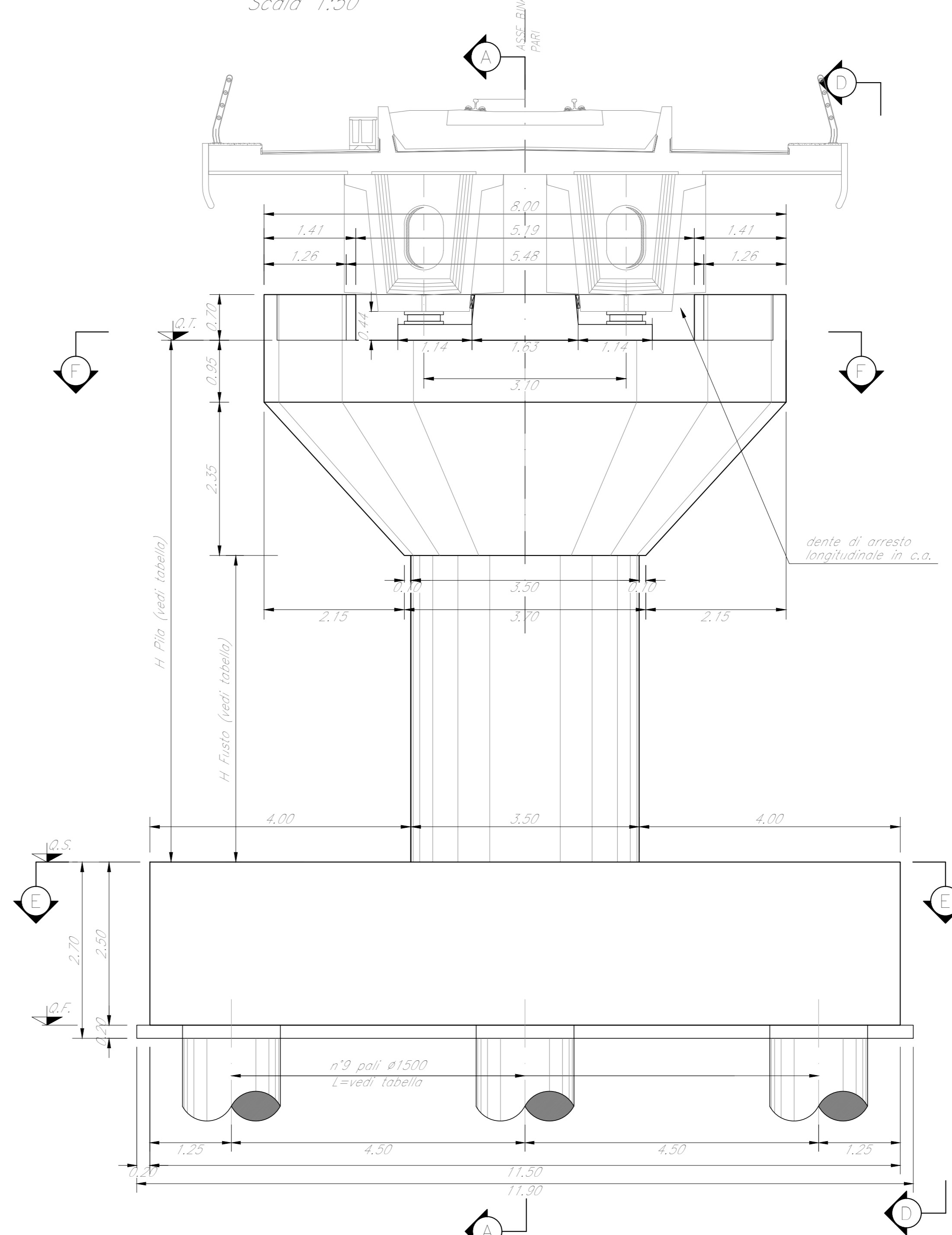

VISTA D-D  
Scala 1:50

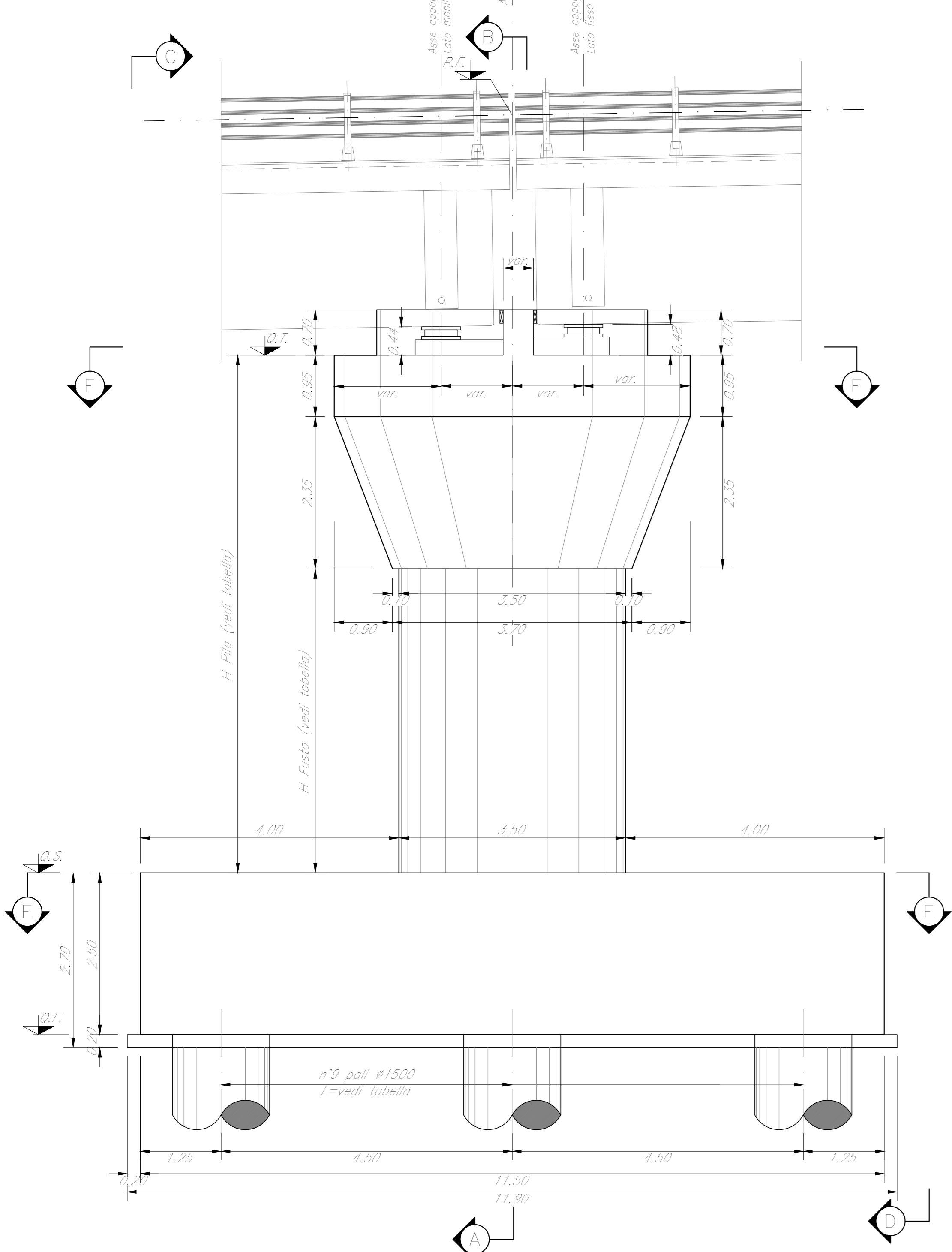

SEZIONE E-E  
Scala 1:50

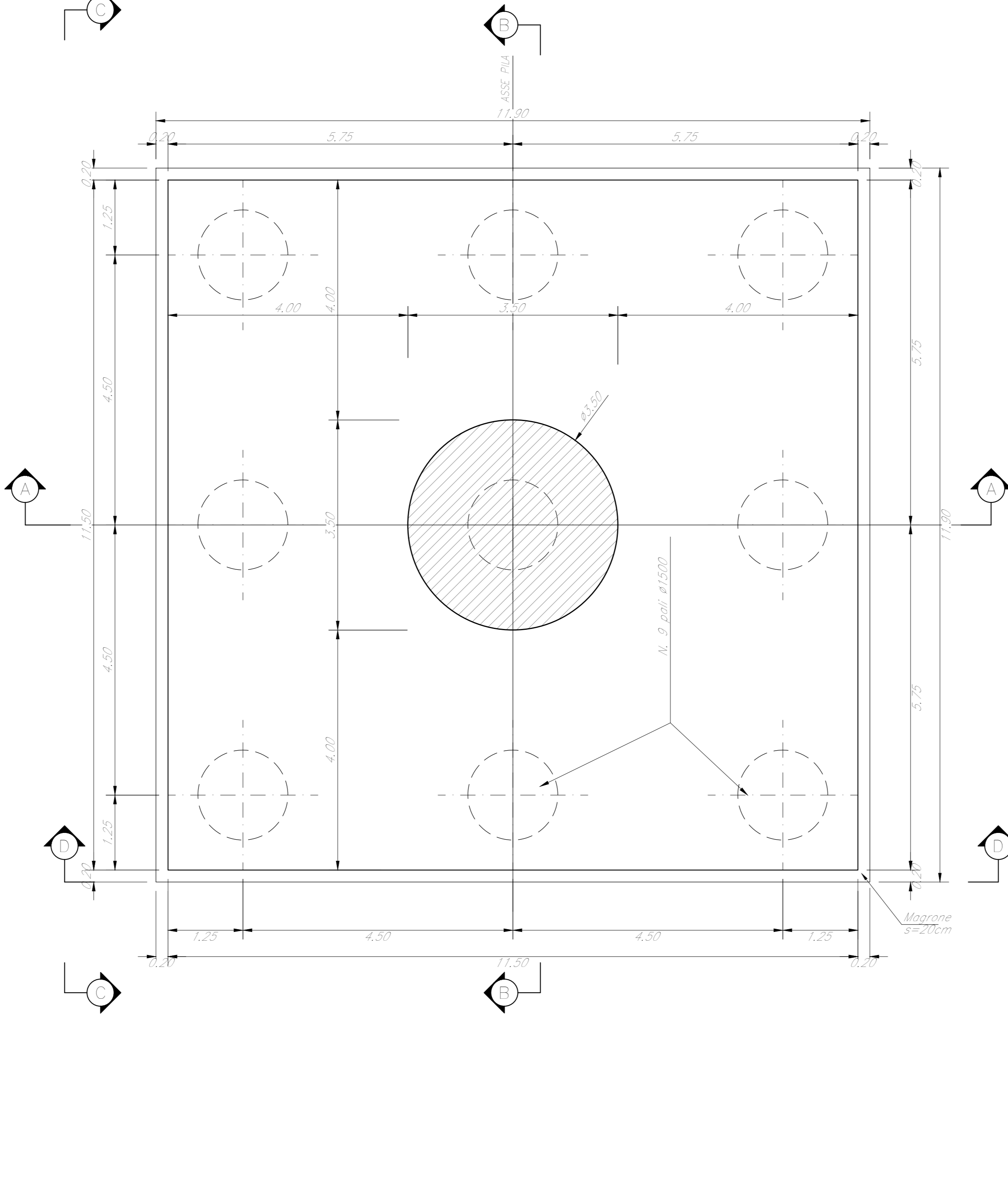

SEZIONE F-F  
Scala 1:50



TABELLA PILE (m)

Pila	P.F.	Q.T.	Q.S.	Q.F.	H Fusto	H Pila	L Pali
P31	+336,63	+332,92	+314,62	+312,12	15,00	18,30	36,00
P32	+337,03	+333,32	+314,52	+312,02	15,50	18,80	36,00
P33	+337,43	+333,72	+314,92	+312,42	15,50	18,80	36,00

NOTE:

- 1) Per la tabella materiali, note generali e incidenze fare riferimento al documento RS3T30009111000001 - Materiali e prescrizioni generali.
- 2) v = 90 mm

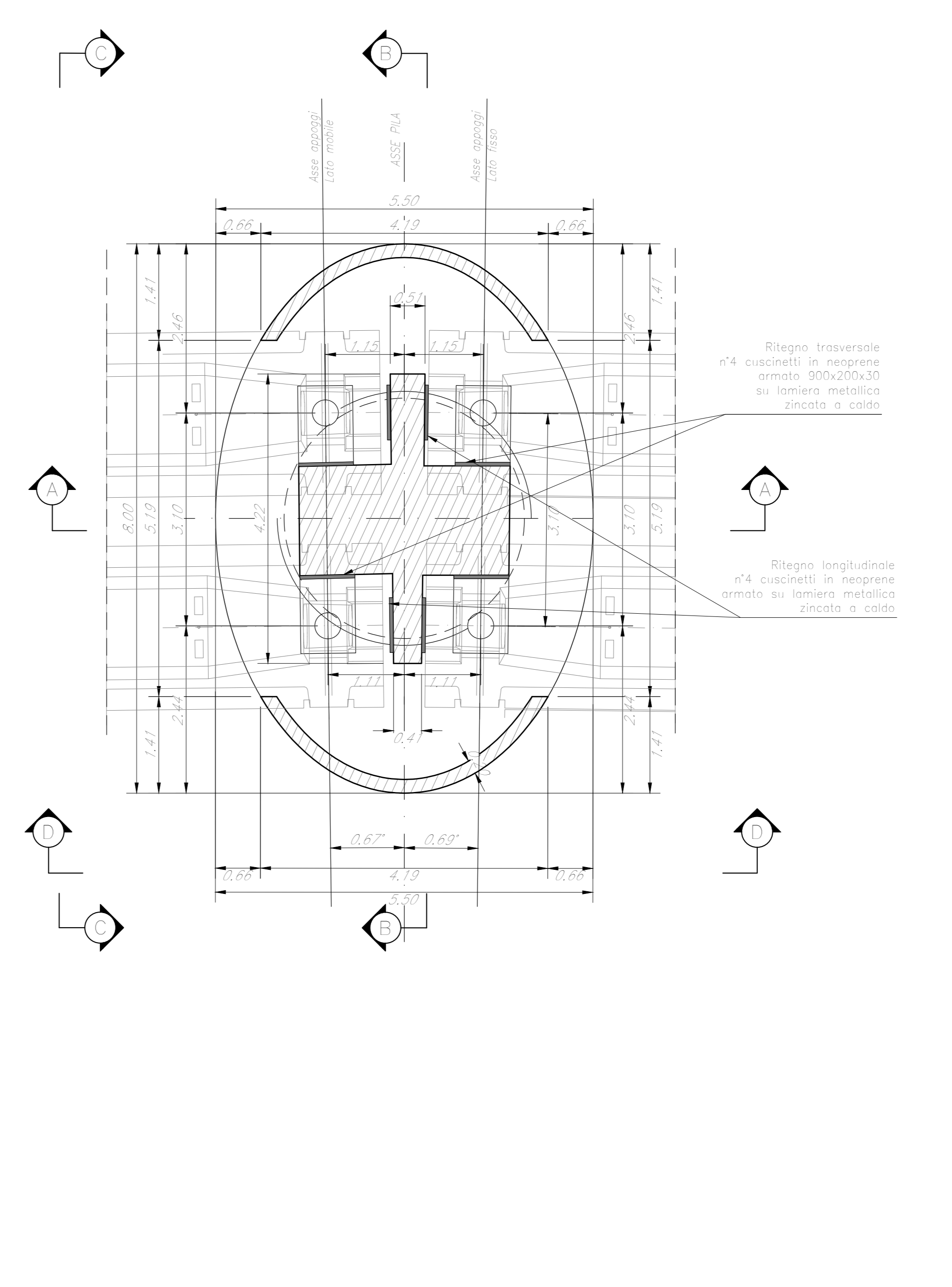
COMMITTEE:



PROGETTAZIONE:



DIRETTRICE FERROVIARIA MESSINA - CATANIA - PALERMO

NUOVO COLLEGAMENTO PALERMO - CATANIA

U.O. OPERE CIVILI E GESTIONE DELLE VARIANTI

PROGETTO DEFINITIVO

TRATTA LERCARA DIR. - CALTANISSETTA XIRBI (LOTTO 3)

V117 - Viadotto ferroviario, Singolo Binario  
Carpenteria Pila P31 - Pila P32 - Pila P33

SCALA:

Varie

COMMESSA LOTTO FASE ENTE TIPO DOC. OPERA/DISCIPLINA PROGR. REV.

RS3T 30 D 09 BZ V11705 025 C

Rev.	Descrizione	Redatto	Data	Verificato	Data	Approvato	Data	Autorizzato	Data
A	Emissione esecuzione	G. Giraldi	Gen 2020	A. Fedi	Gen 2020	A. Banca	Gen 2020	A. Vassù	Mag 2020
B	Emissione esecuzione	G. Giraldi	Feb 2020	A. Fedi	Feb 2020	A. Banca	Feb 2020	A. Vassù	Mag 2020
C	1° app e consegna CBL/PP	G. Giraldi	Mag 2020	A. Fedi	Mag 2020	A. Banca	Mag 2020	A. Vassù	Mag 2020