

SEZIONE A-A  
Scala 1:50

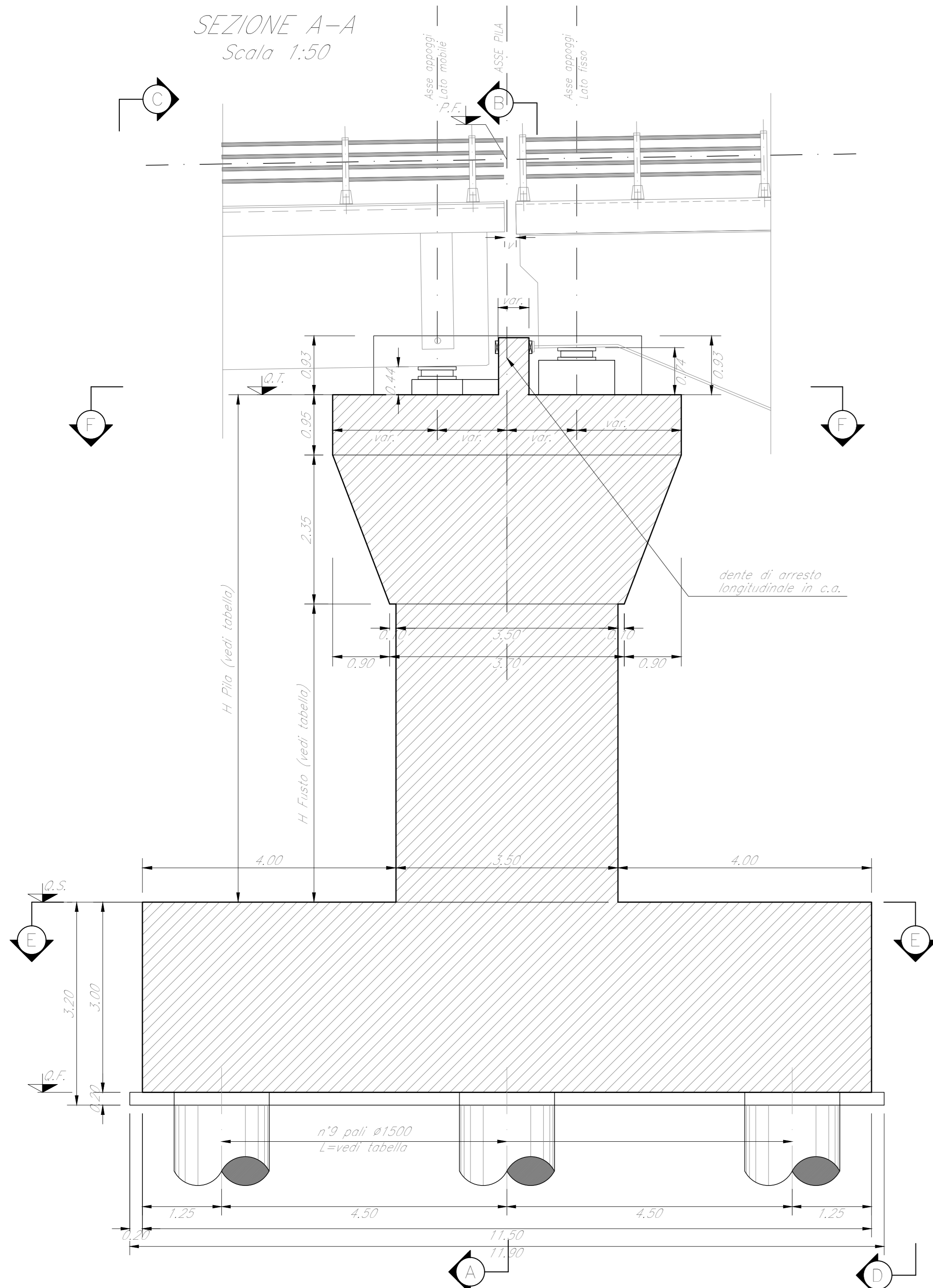

SEZIONE B-B  
Scala 1:50

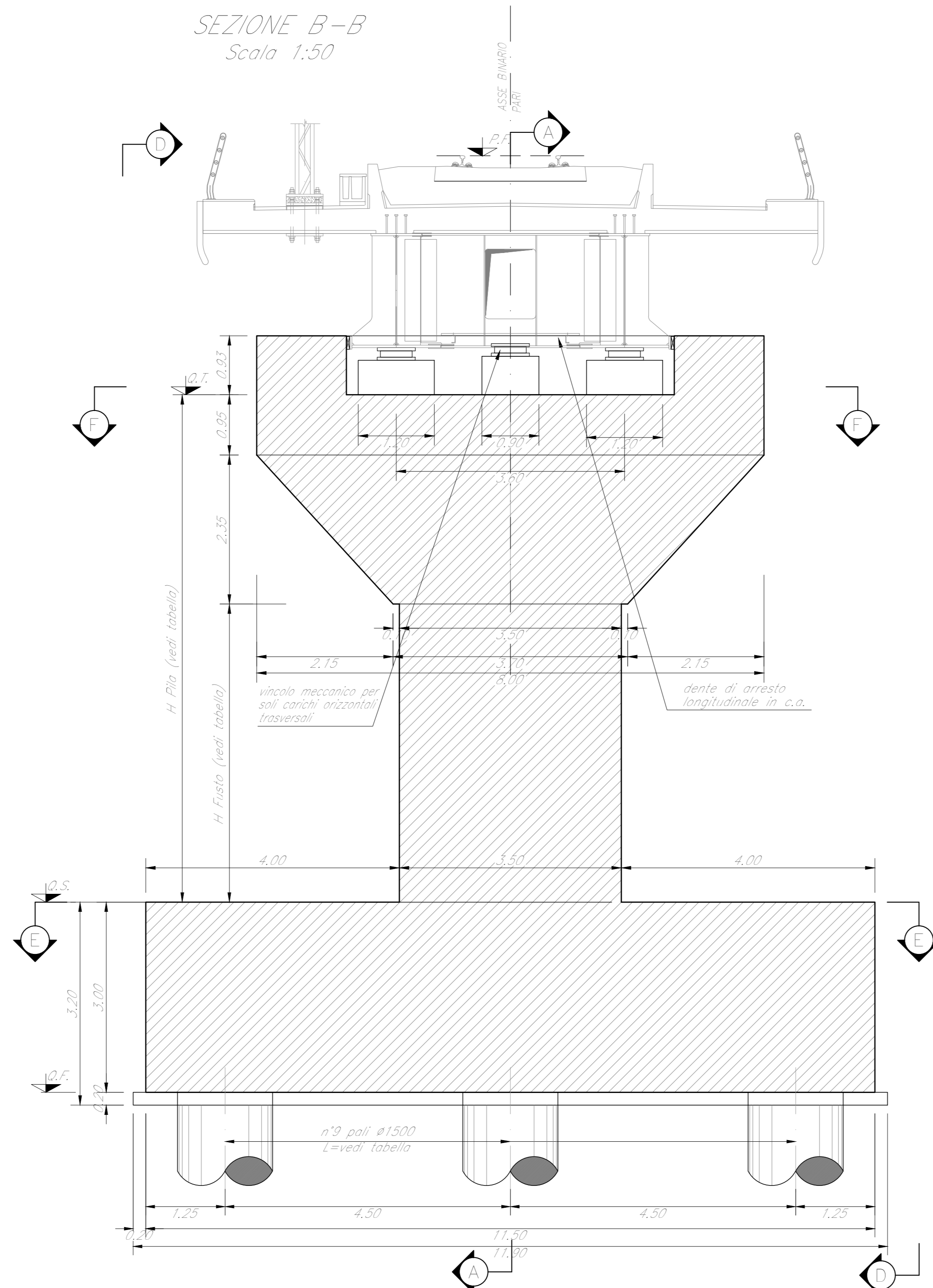

VISTA C-C  
Scala 1:50

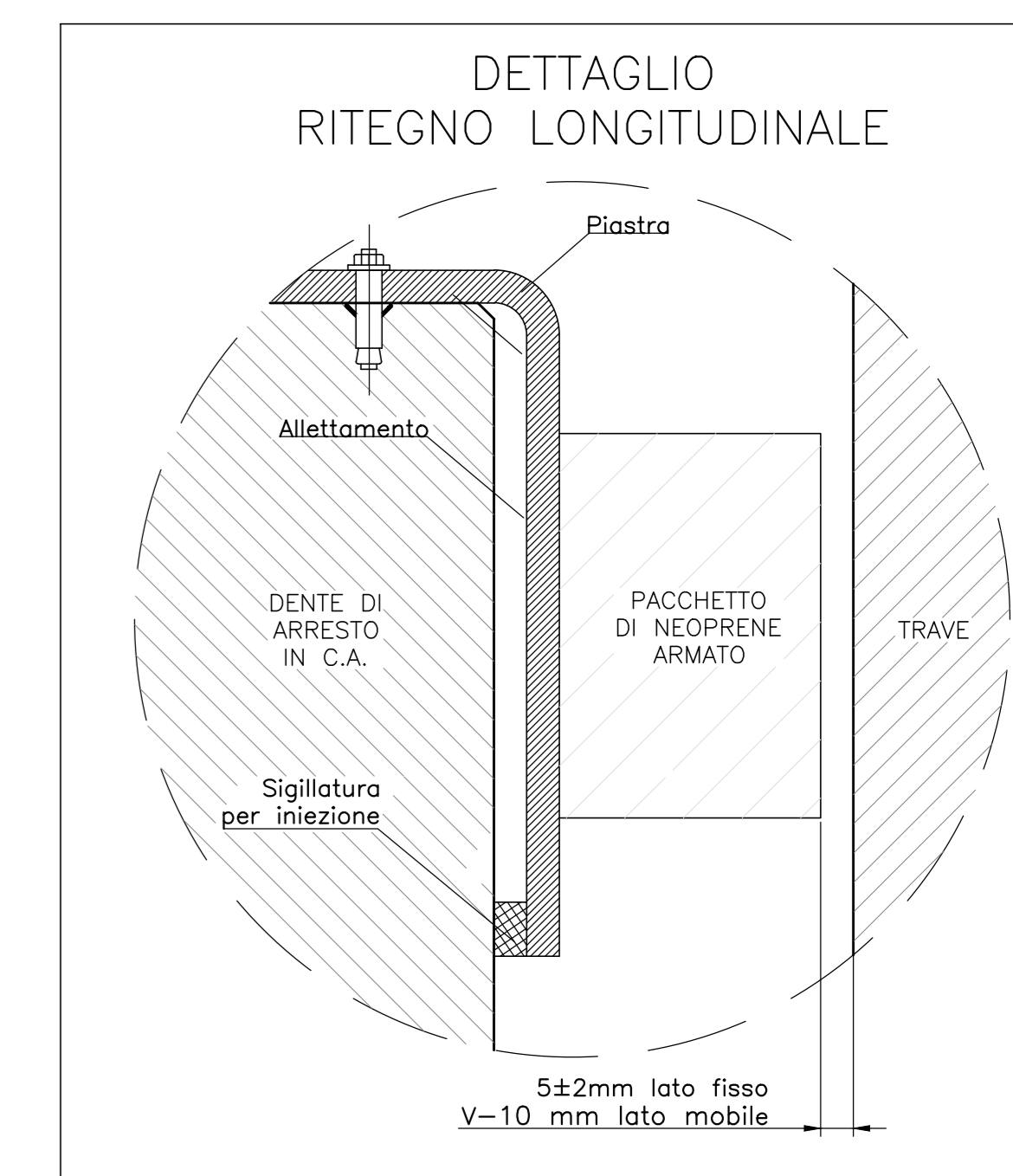
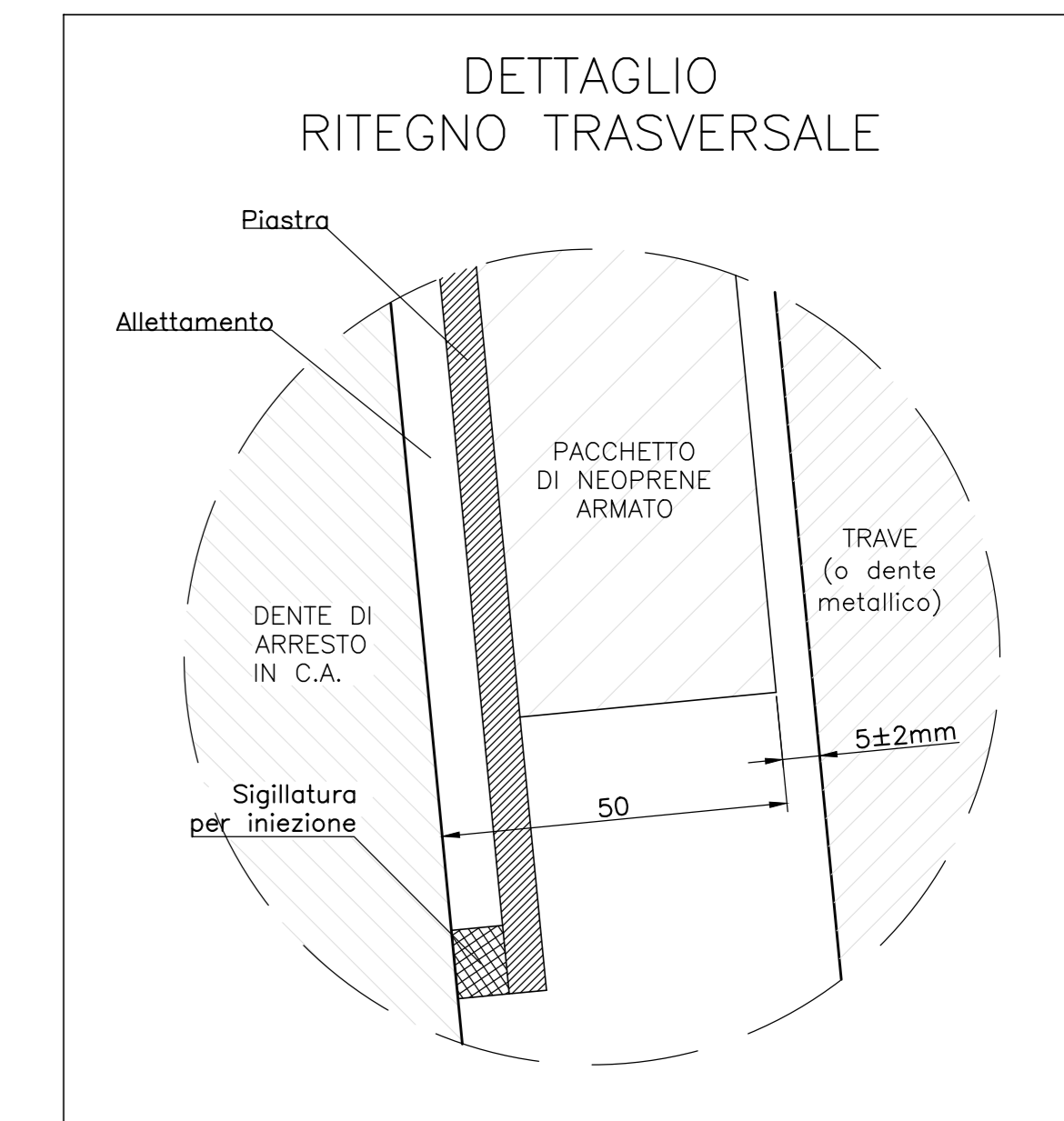
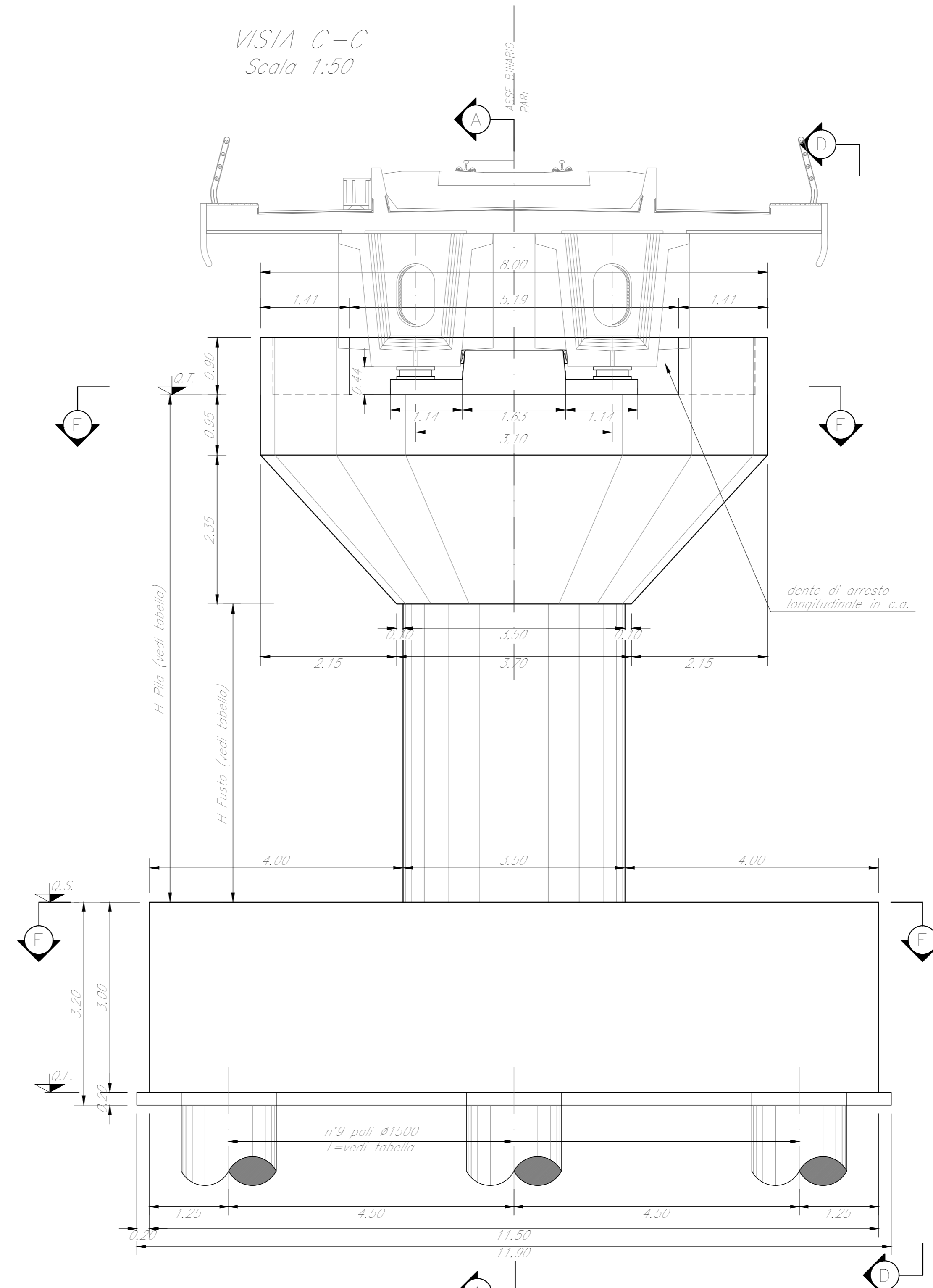

VISTA D-D  
Scala 1:50

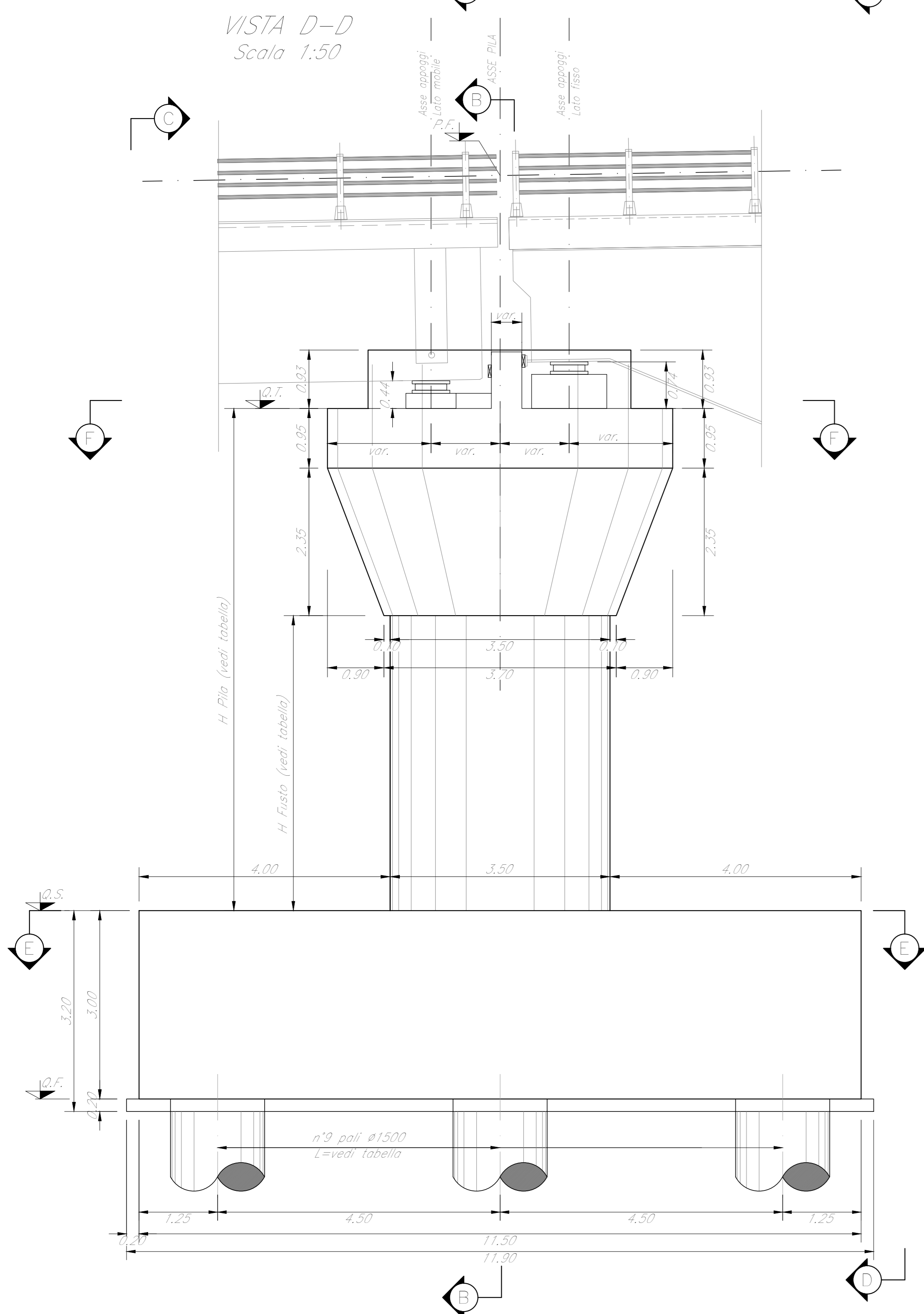

SEZIONE E-E  
Scala 1:50

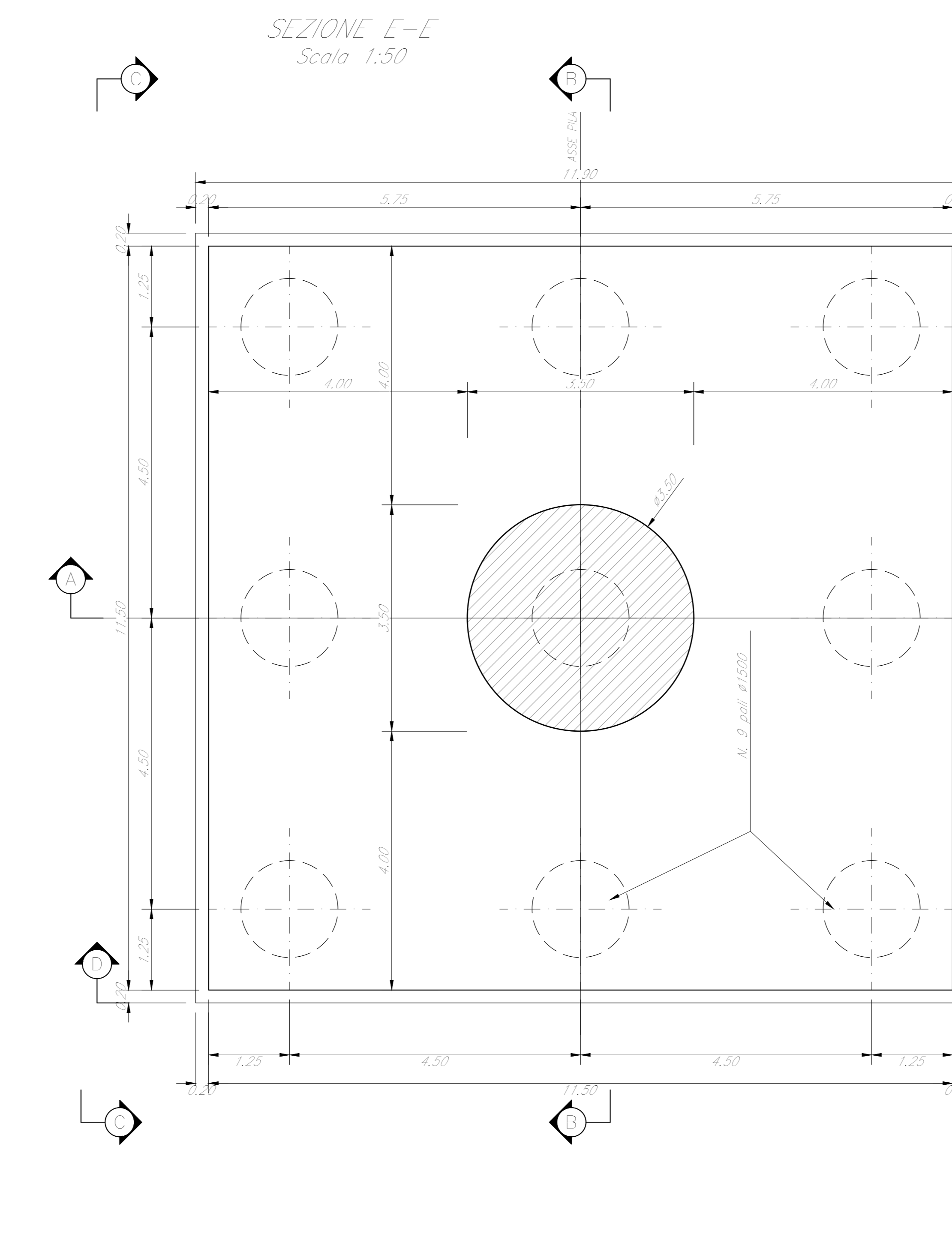

SEZIONE F-F  
Scala 1:50



TABELLA PILE (m)

Pila	P.F.	Q.T.	Q.S.	Q.F.	H. Fusto	H. Pila	L. Pila
P37	+338,03	+335,32	+317,02	+314,02	15,00	18,30	40,00

NOTE:  
1) Per la tabella materiali, note generali e incidenze fare riferimento al documento RS3T30D0911V1000001 - Materiali e prescrizioni generali.  
2) v = 120 mm

COMMITTENTE: **RFI** RETE FERROVIARIA ITALIANA GRUPPO FERROVIE DELLO STATO ITALIANE

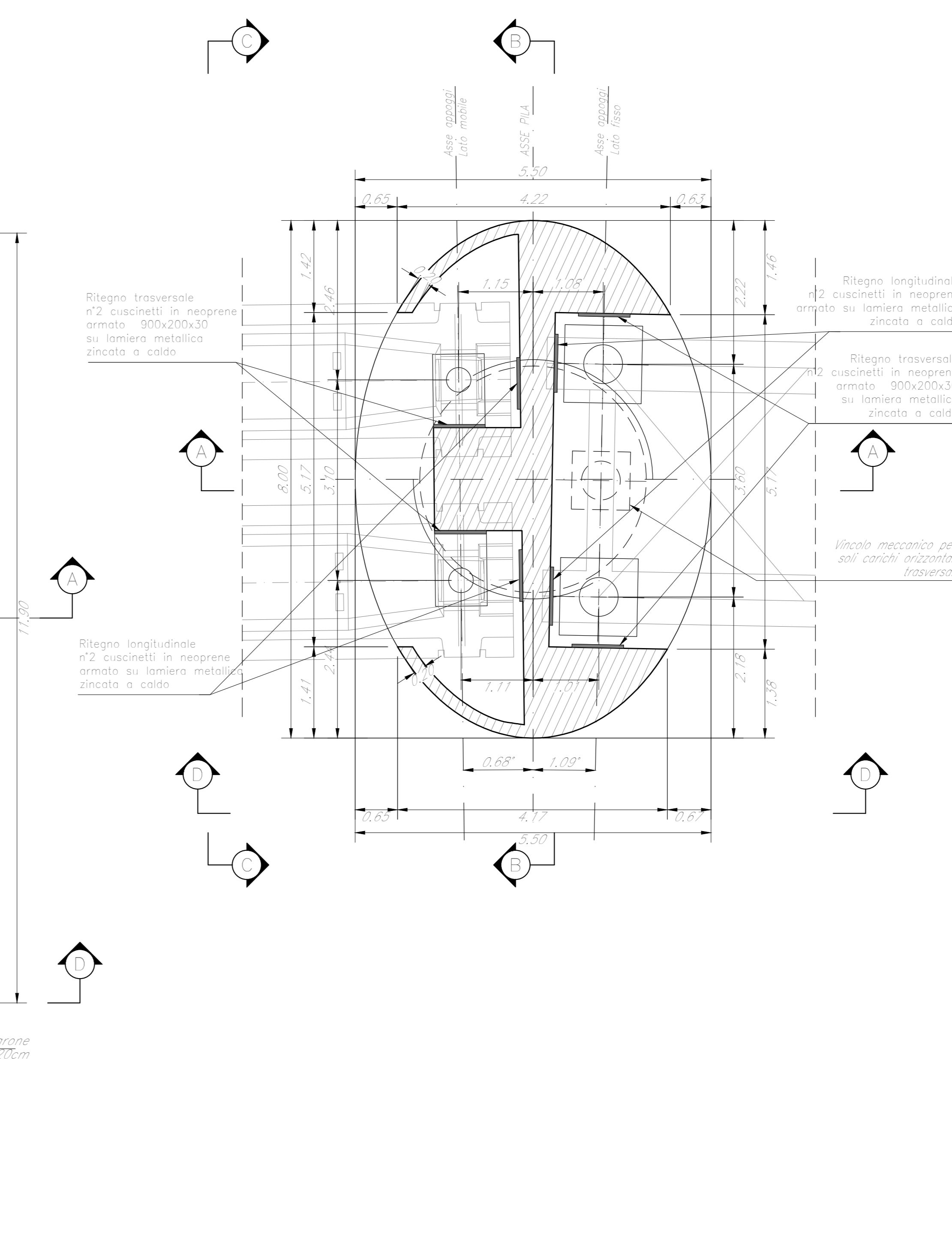
PROGETTAZIONE: **ITALFERR** GRUPPO FERROVIE DELLO STATO ITALIANE

**DIRETTRICE FERROVIARIA MESSINA - CATANIA - PALERMO**  
**NUOVO COLLEGAMENTO PALERMO - CATANIA**

**U.O. OPERE CIVILI E GESTIONE DELLE VARIANTI**

**PROGETTO DEFINITIVO**  
**TRATTA LERCARA DIR. - CALTANISSETTA XIRBI (LOTTO 3)**

V117 - Viadotto ferroviario, Singolo Binario  
Carpenteria Pila P37

SCALA: **Varie**

Rev.	Descrizione	Redatto	Data	Verificato	Data	Approvato	Data	Autorizzato	Data
A	Emissione messina	G. Giraldi	Gen. 2020	A. Fedi	Gen. 2020	A. Banca	Gen. 2020	A. Vassù	Mag. 2020
B	Emissione catania	G. Giraldi	Feb. 2020	A. Fedi	Feb. 2020	A. Banca	Feb. 2020	A. Vassù	Mag. 2020
C	1° app. e consegna CSLLPP	G. Giraldi	Mag. 2020	A. Fedi	Mag. 2020	A. Banca	Mag. 2020	A. Vassù	Mag. 2020

File:RS3T30D09BZV1170527C.dwg