

16VH001
DEGASATORE ACQUA DI PROCESSO

16VA001
SERBATOIO DRENAGGI CHIUSI

NOTES:

- BD BLOW DOWN
- UN UTILITIES NITROGEN

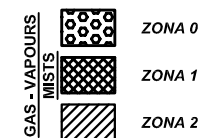
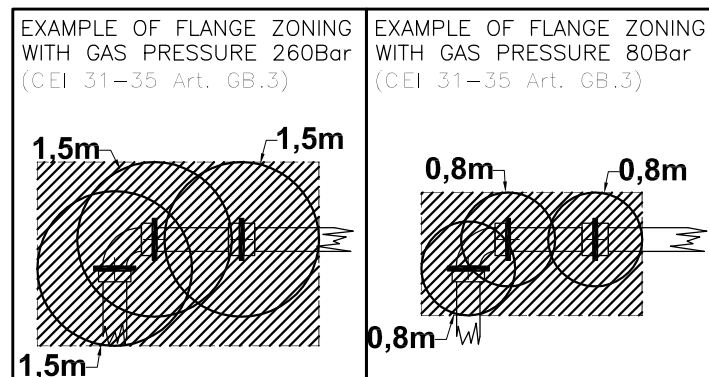

2

Hazardous area D.lgs.81/08
UNIT 16 - Closed Drain System
PFD
DRAFT

CUSTOMER: **GAS PLUS STORAGE S.r.l.**
San Benedetto gas Field

SCALE -/- by SG

DATE 26/07/2010 CHECKED by IB - MC

Documento riservato a termini di Legge con divieto di riproduzione e di divulgazione senza esplicita autorizzazione.
This document is reserved as by law enacted, and cannot be used by others for any purpose, without prior written consent.



Via Monviso n.27
12037 SALUZZO (CN) - ITALY
tel./fax +39.0175.41146/0175.217556
e-mail: info@eteasicurezza.it