

02VN001A/2A/3A/4A Separatore Ingresso 1° Stadio   
 02VN001B/2B/3B/4B Separatore Ingresso 2° Stadio   
 02VN001C/2C/3C/4C Separatore Uscita   
 02KB001/2/3/4 Compressore   
 02HC001/2/3/4 Raffreddatore ad Aria

**NOTES:**  
 BLOW DOWN HIGH PRESSURE

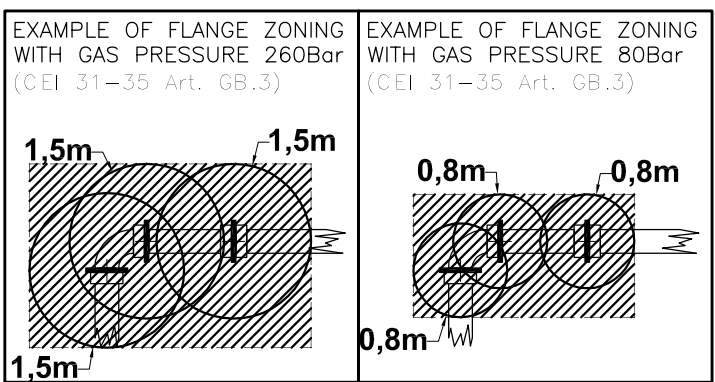

GAS - VAPOURS    ZONA 0  
 MISTS    ZONA 1  
 ZONA 2

|   |                                     |  |
|---|-------------------------------------|--|
| <b>3</b>  | <b>Hazardous area D.lgs.81/08</b>   |  |
|   | <b>UNIT 02 - Compression System</b> |  |
| <b>PFD</b>  |                                     |  |
| <b>DRAFT</b>  |                                     |  |
| <b>CUSTOMER: GAS PLUS STORAGE S.r.l.</b>  |                                     |  |
| <b>San Benedetto gas Field</b>  |                                     |  |
| SCALE -/-   | by SG                               |  |
| DATE 26/07/2010   | CHECKED by IB - MC                  |  |
| Documento riservato a termini di Legge con divieto di riproduzione e di divulgazione senza esplicita autorizzazione.<br>This document is reserved as by law enacted, and cannot be used by others for any purpose, without prior written consent. |                                     |  |
|   |                                     | Via Monviso n.27<br>12037 SALUZZO (CN) - ITALY<br>tel./fax +39.0175.41146/0175.217556<br>e-mail: info@eteasicurezza.it |