

SEZIONE A-A
Scala 1:50

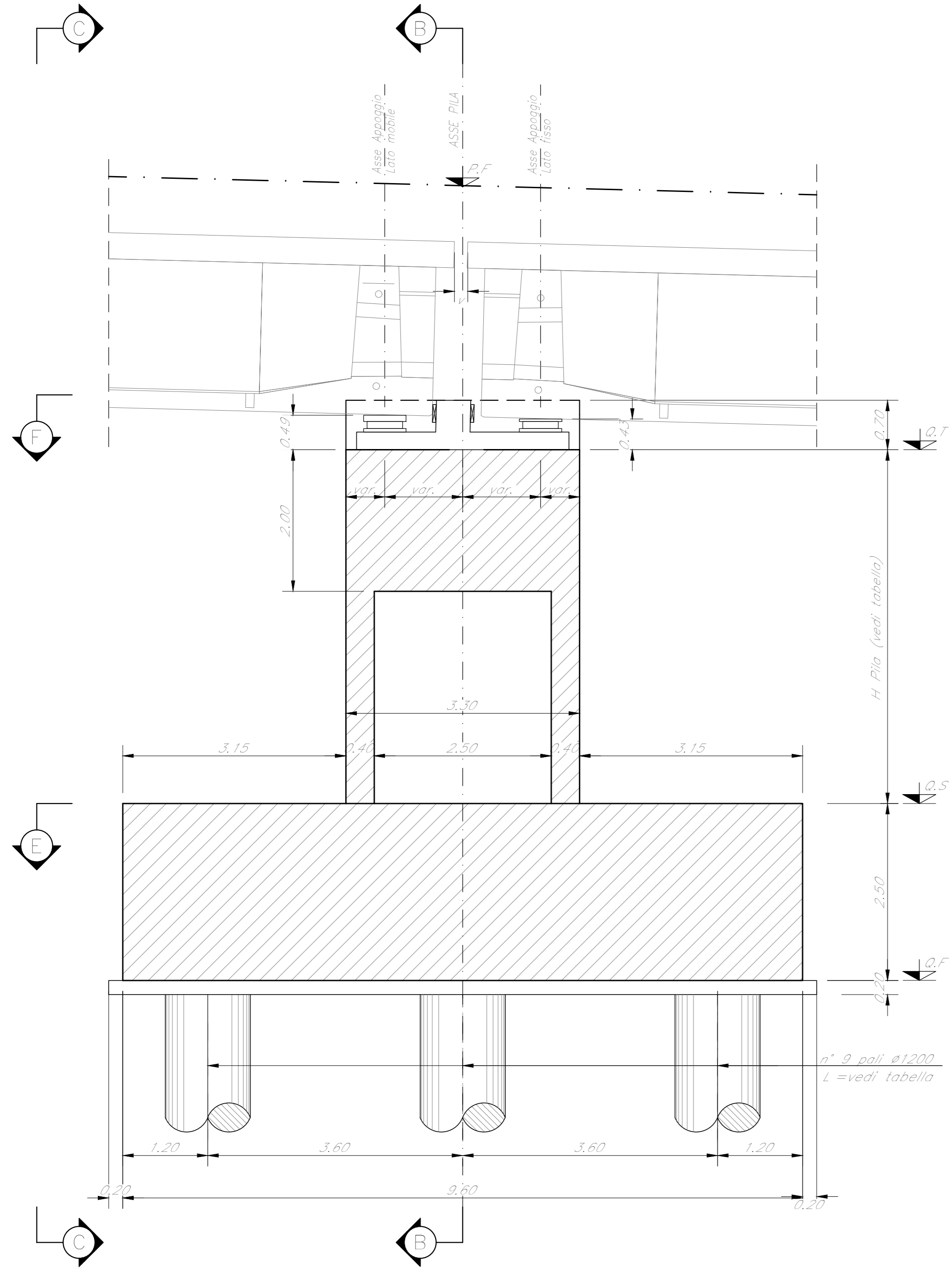

SEZIONE B-B
Scala 1:50

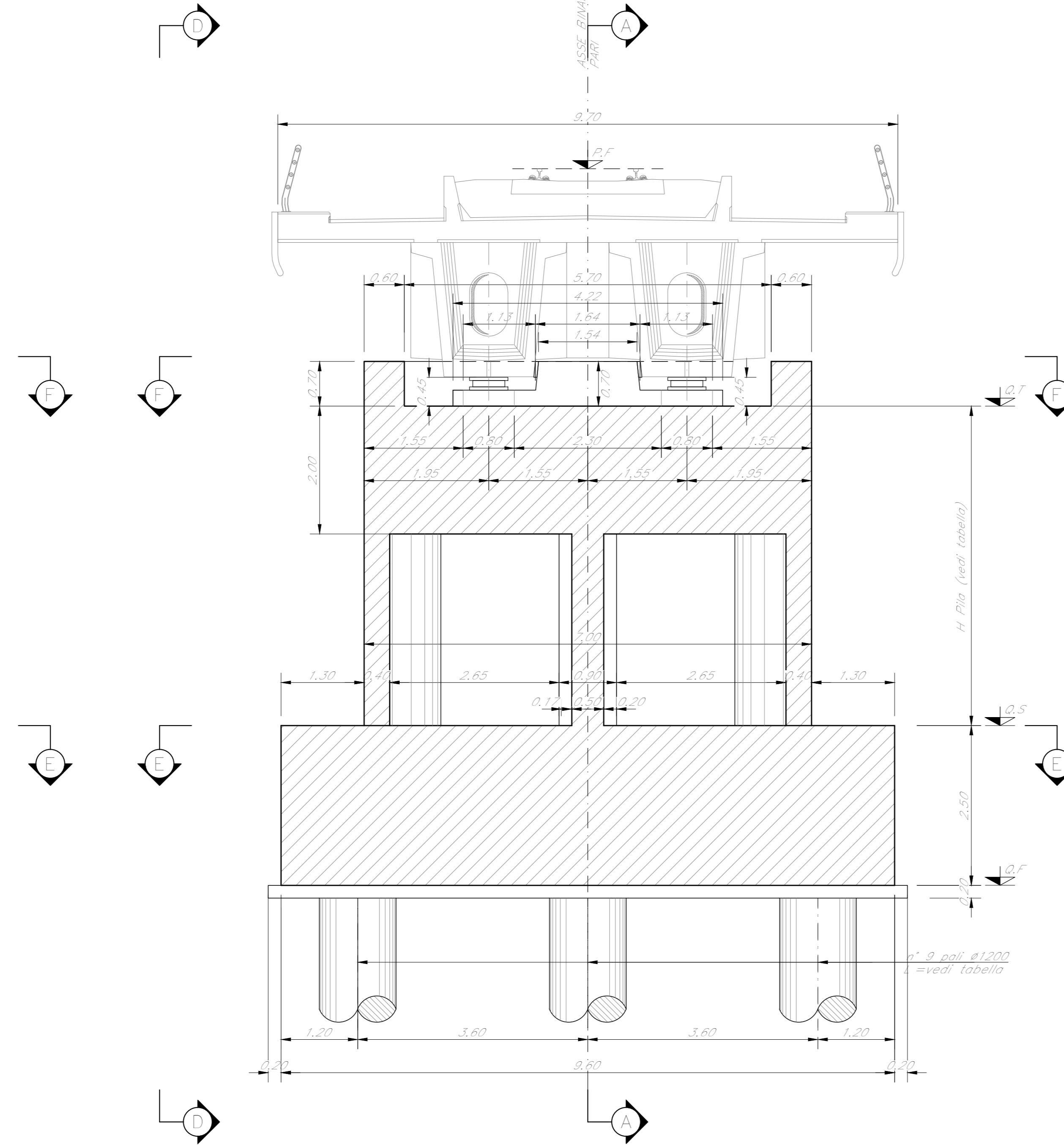

SEZIONE C-C
Scala 1:50

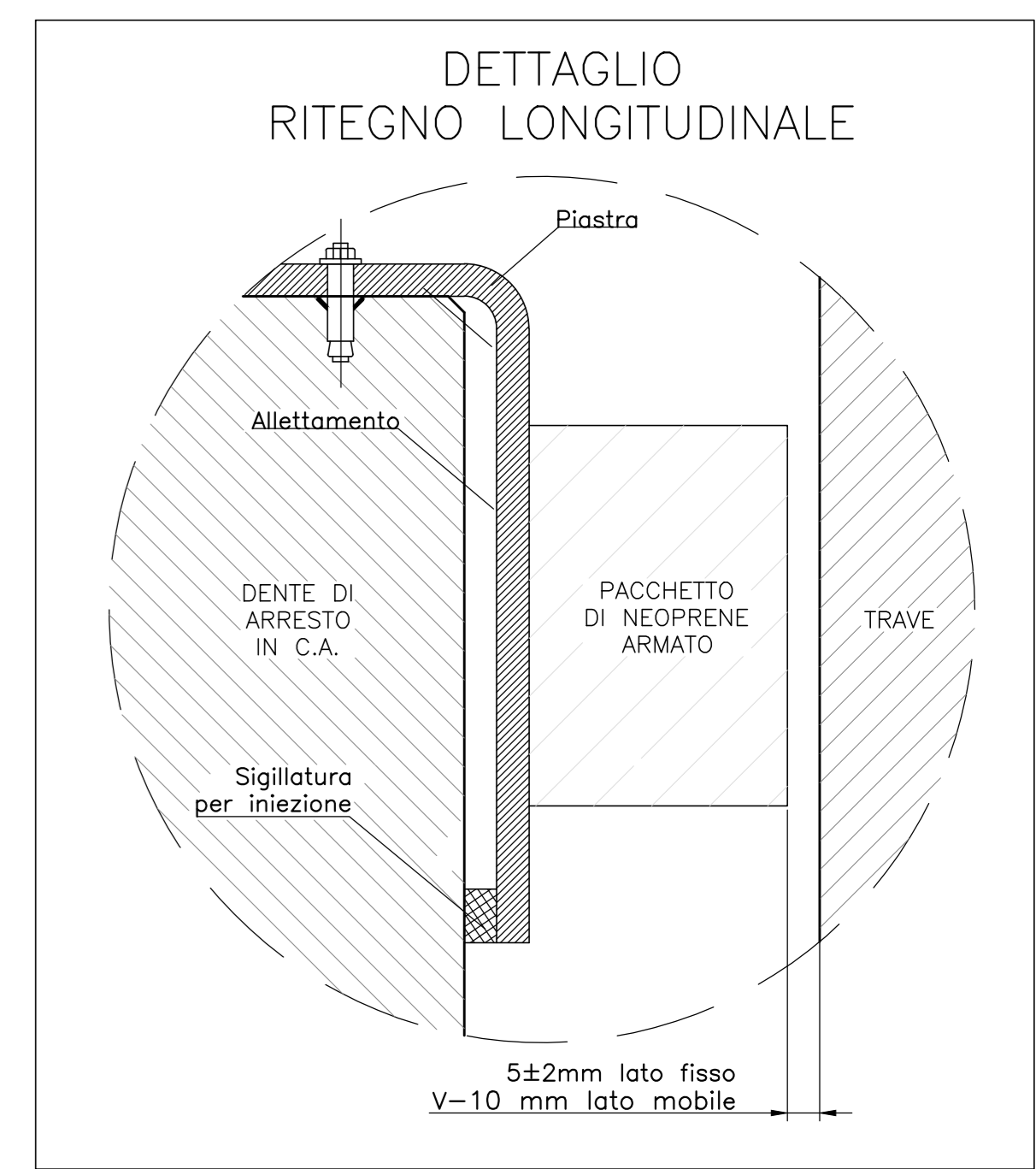
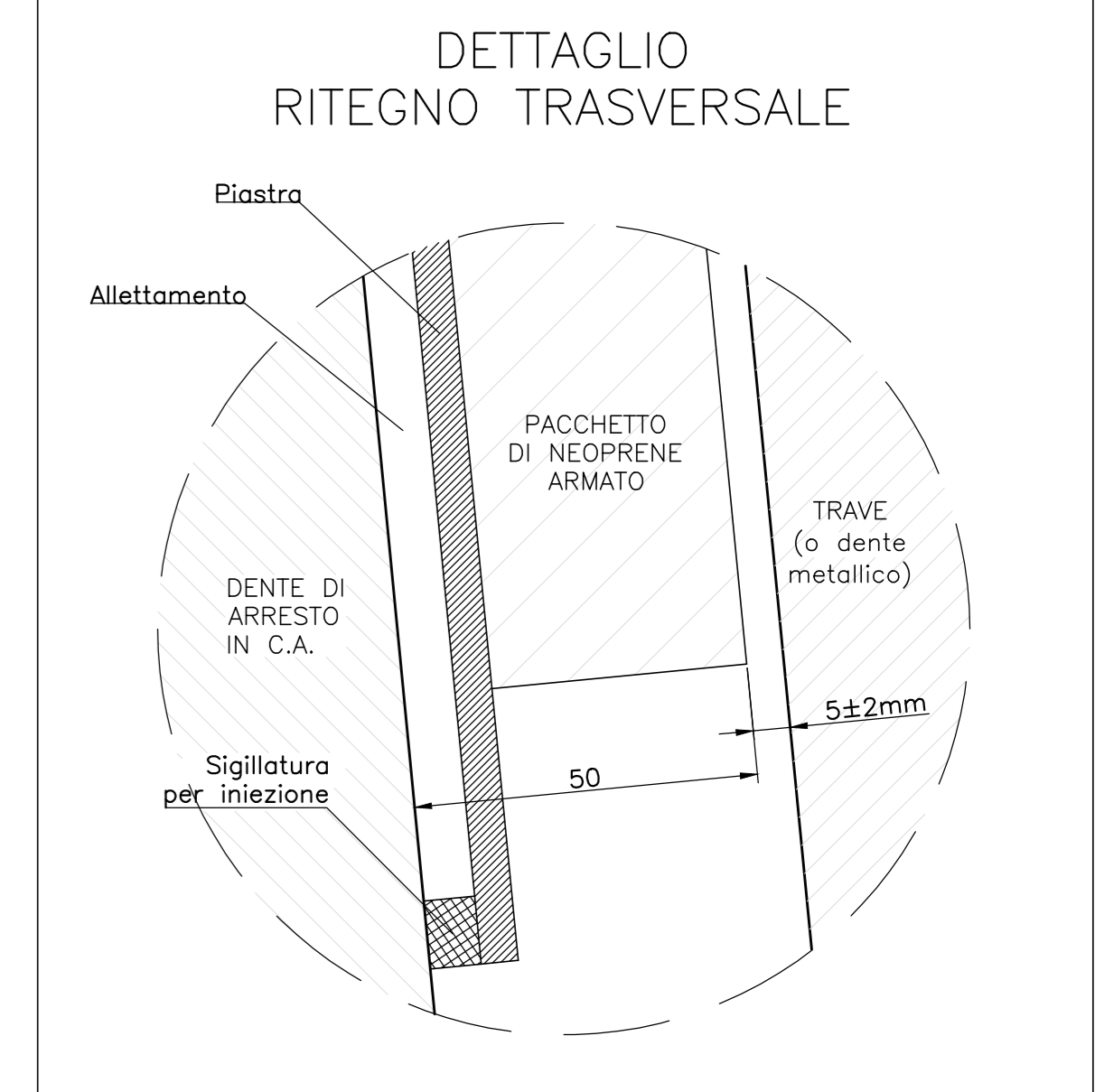
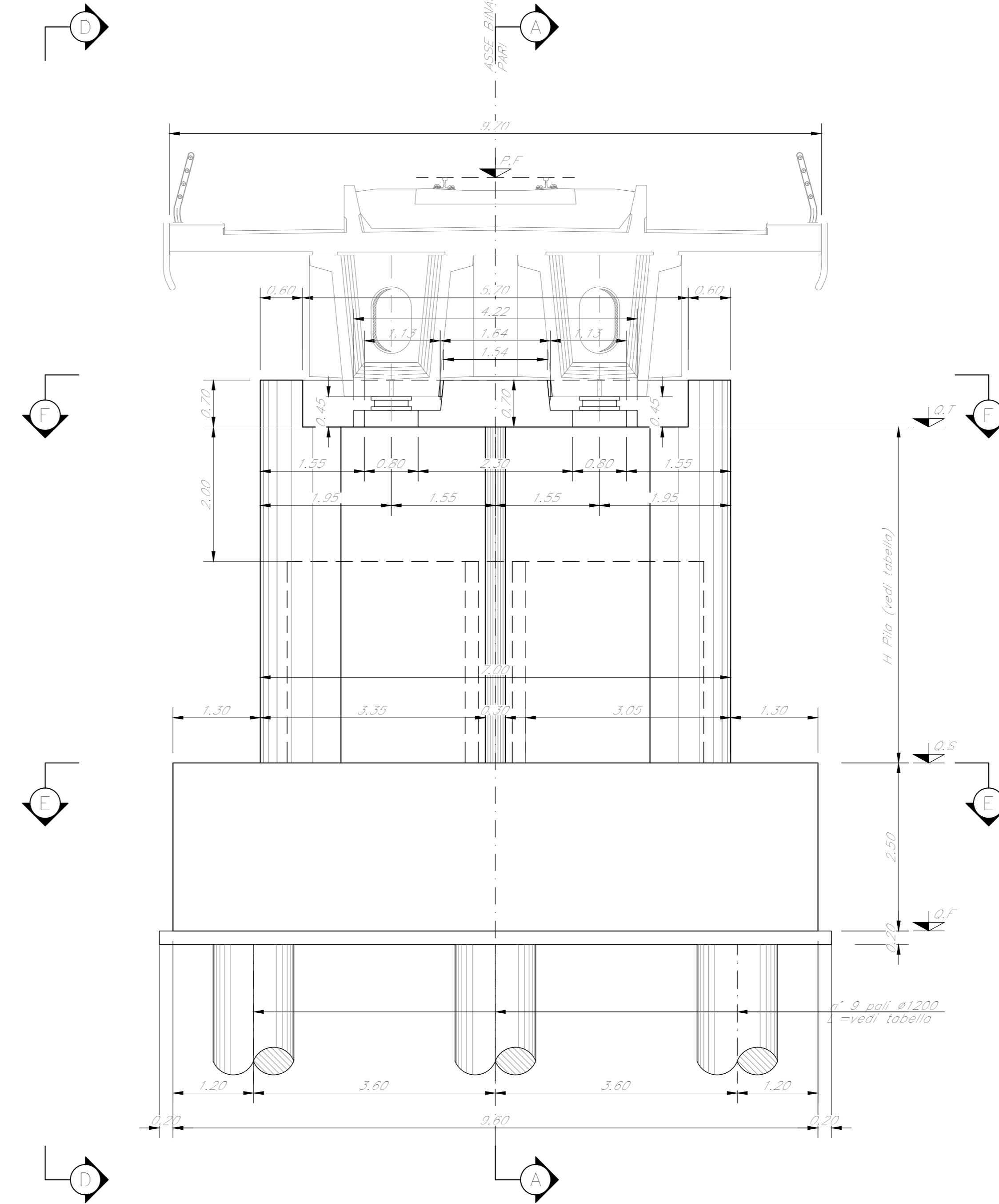

VISTA D-D
Scala 1:50

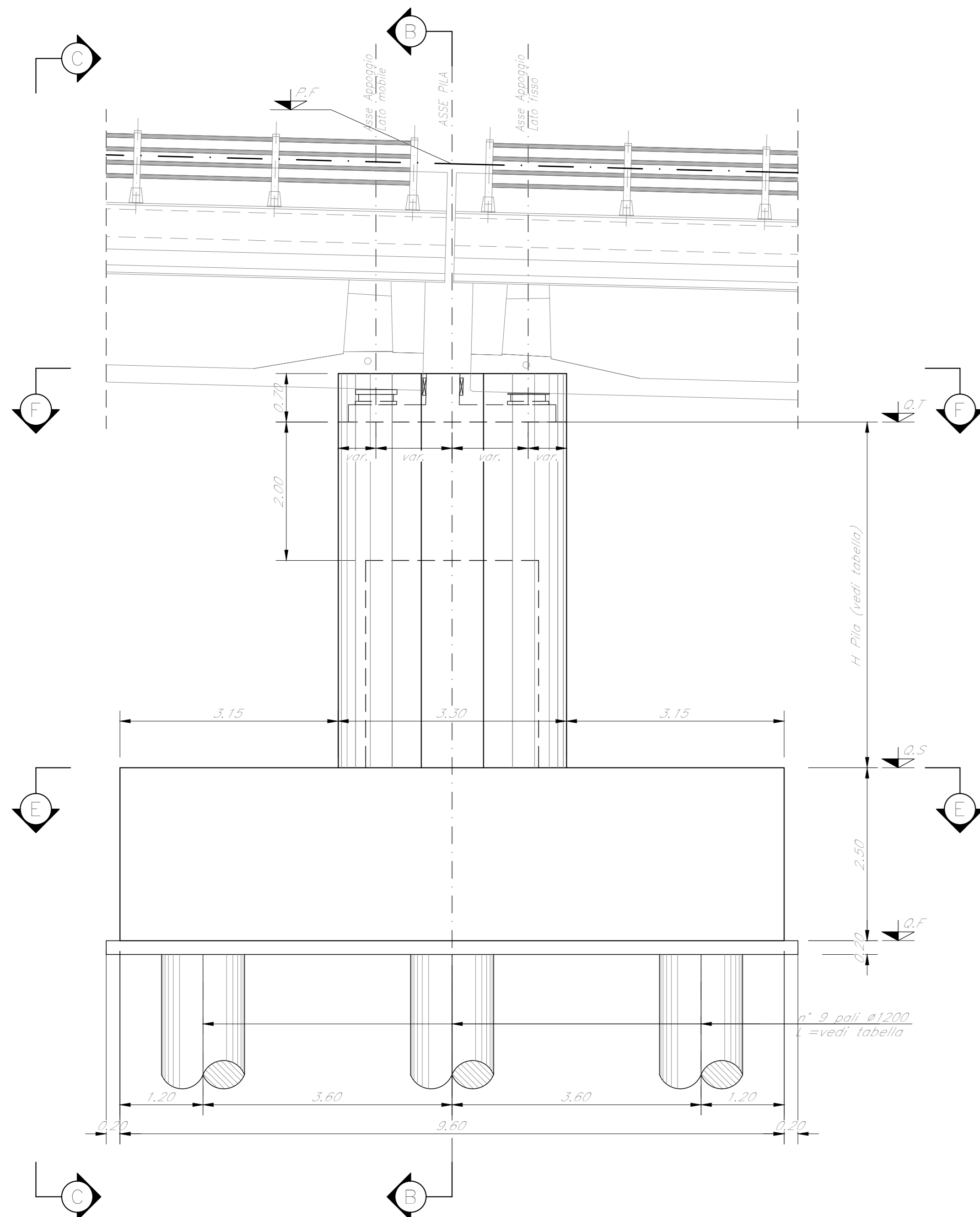

SEZIONE E-E
Scala 1:50

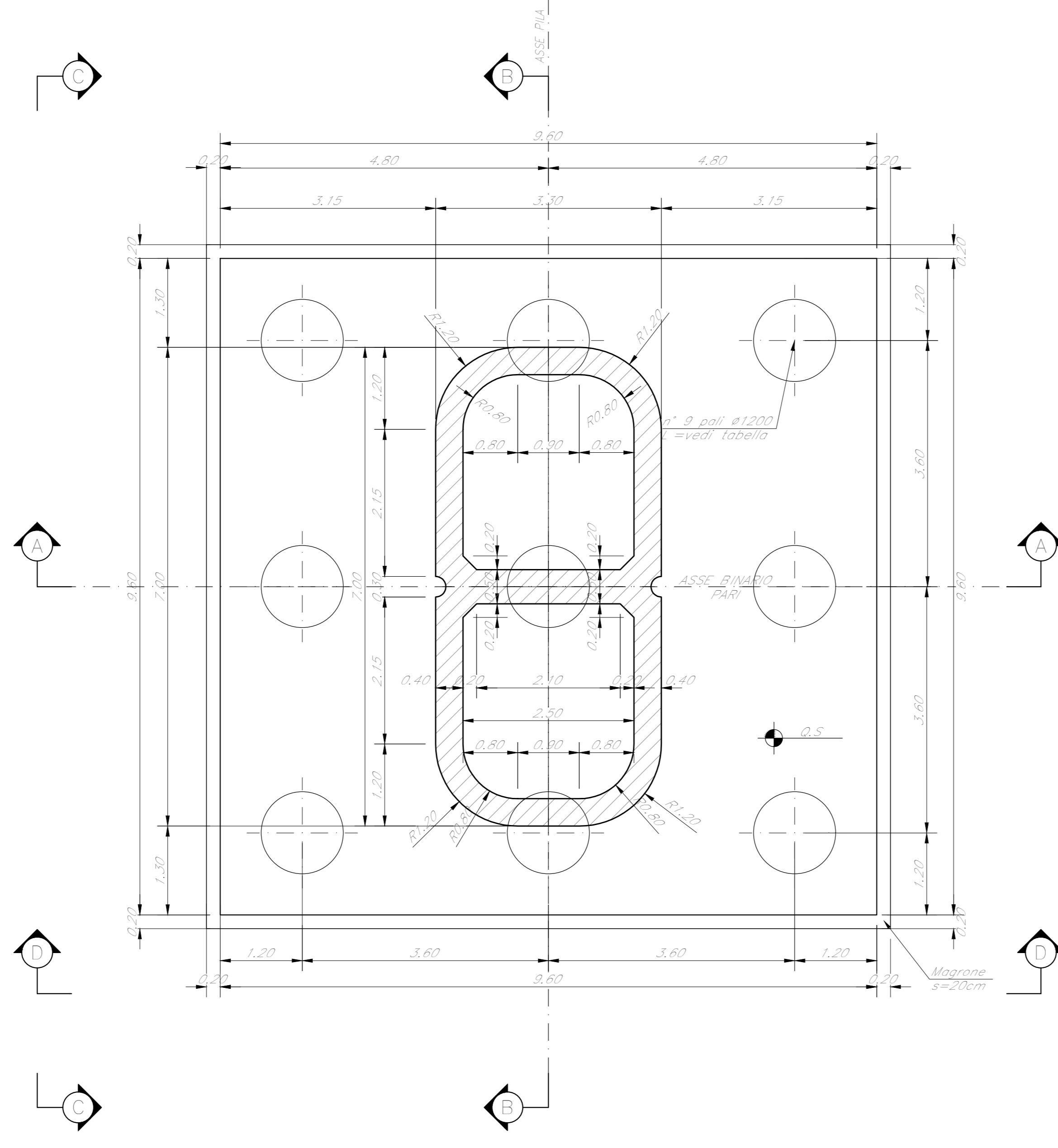

SEZIONE F-F
Scala 1:50



TABELLA PILE (m)

Pila	P.F.	Q.T.	Q.S.	Q.F.	H Pila	L.Pila
P3	+398,74	+396,01	+398,01	+388,51	8,00	28,00

NOTE:
1) Per la tabella materiali, note generali e incidere fare riferimento al documento 783U40009BZV105003C - Materiali e prescrizioni generali.
2) V= 90mm

COMMITTENTE: **RFI** RETE FERROVIARIA ITALIANA GRUPPO FERROVIE DELLO STATO ITALIANE

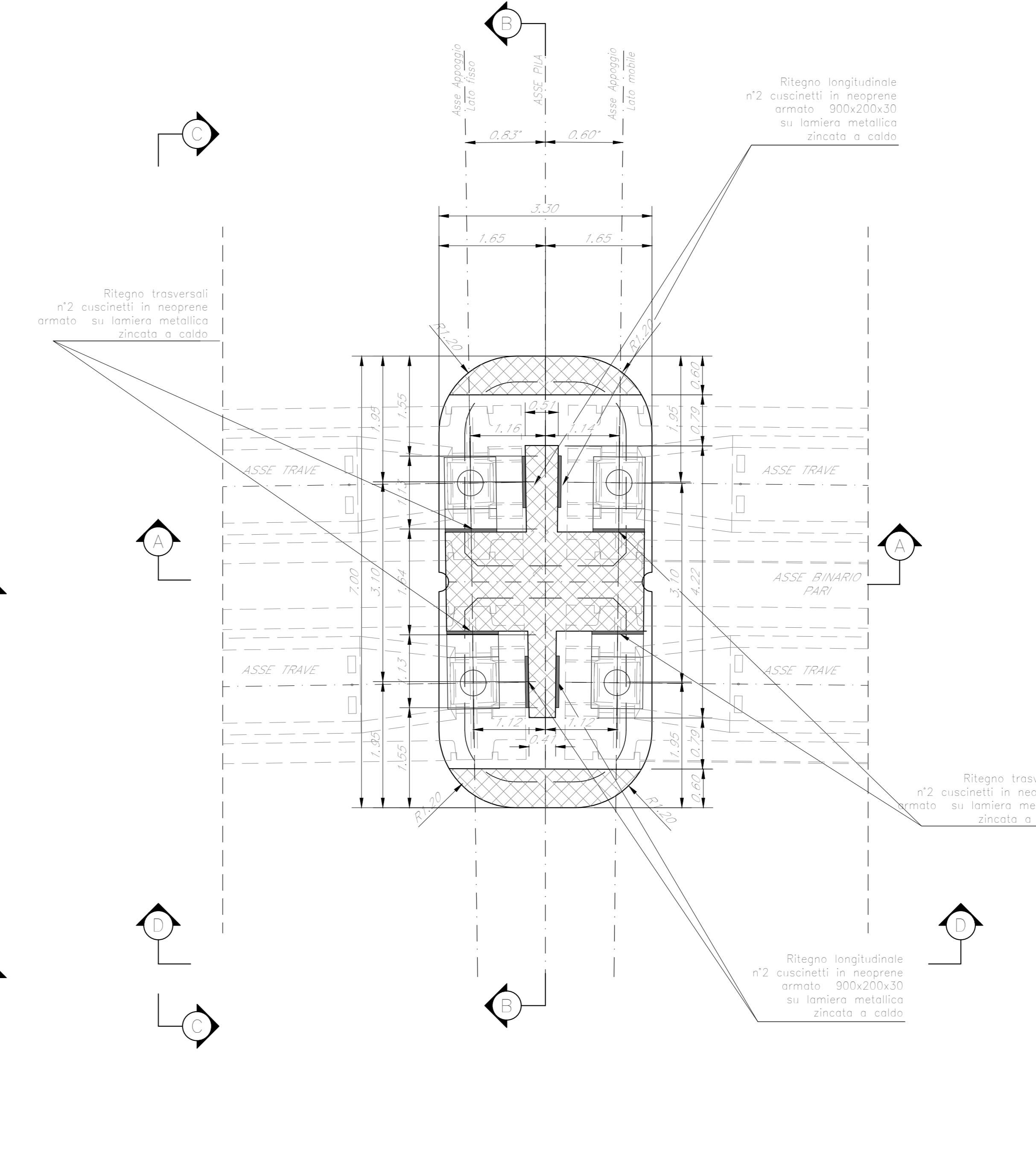
PROGETTAZIONE: **ITALFER** INFRASTRUTTURE FERROVIARIE

DIRETTRICE FERROVIARIA MESSINA - CATANIA - PALERMO
NUOVO COLLEGAMENTO PALERMO - CATANIA

U.O. OPERE CIVILI E GESTIONE DELLE VARIANTI

PROGETTO DEFINITIVO

TRATTA CALTANISSETTA XIRBI - NUOVA ENNA (LOTTO 4A)

VI051 - Viadotto ferroviario, Singolo Binario
Carpenteria Pila P3

SCALA: **Varie**

COMMESSA	LOTTO	FASE	ENTE	TIPO DOC.	OPERA/DISCIPLINA	PROGR.	REV.
RS3U	40	D	09	BZ	VI05105	003	C

Rev.	Descrizione	Redatto	Data	Verificato	Data	Approvato	Data	Autorizzato Data
A	Emissione esecutiva	G. Girasol	Gen 2020	A. Fico	Gen 2020	A. Bontade	Gen 2020	A. Viorio 17/01/2020
B	1° app a consegna CBLTP	C. Gennari	Mag 2020	A. Fico	Mag 2020	A. Bontade	Mag 2020	18/05/2020

File:RS3U40009BZV105003C.dwg n. Elab.:09_172