

PLANIMETRIA TRACKER [@ 0°] scala 1:200

Tracker da 36 moduli da 555 watt (19,98 kw) - Superficie 94,1 mq

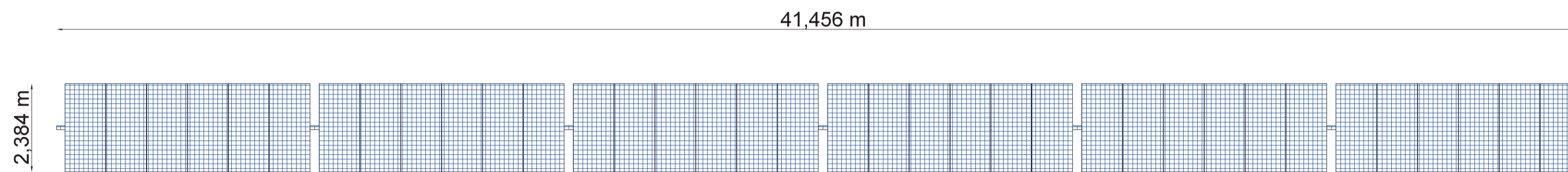

Tracker da 18 moduli da 555 watt (9,99 kw) - Superficie 47,0 mq

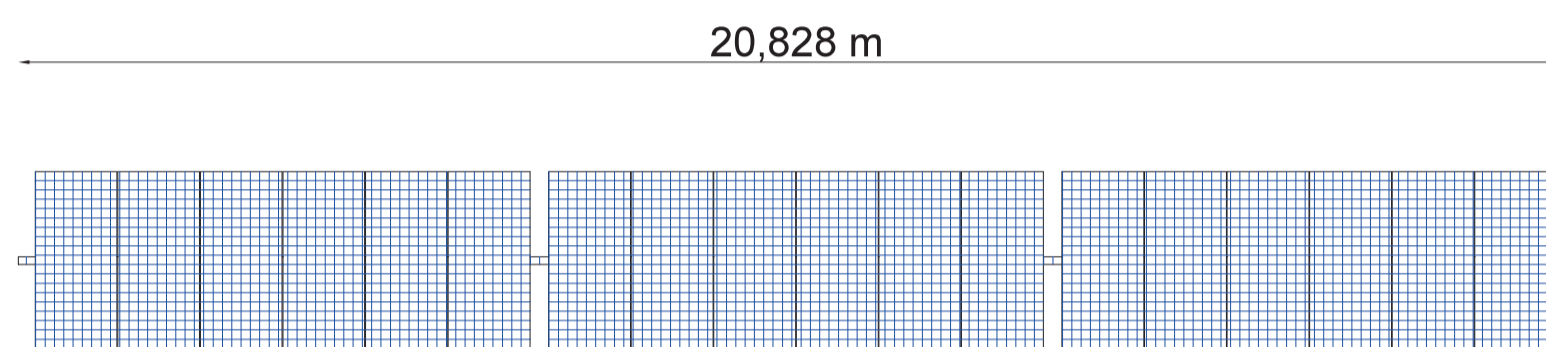

Tracker da 12 moduli da 555 watt (6,66 kw) - Superficie 31,4 mq

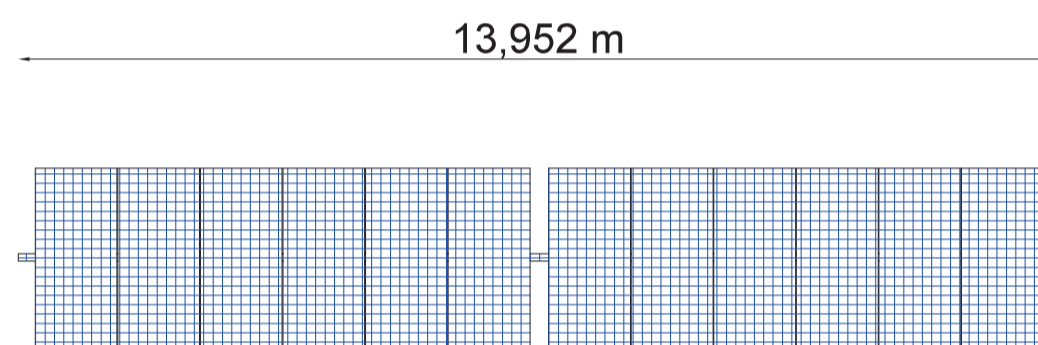

MODULI 555 Wp

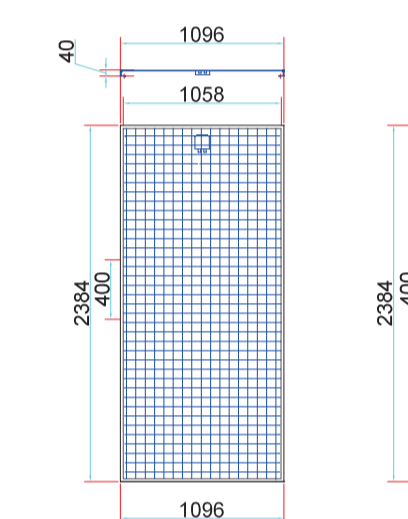

SEZIONI scala 1:100

TRJHT...PDP
SIDE VIEW @ 55°

SIDE VIEW @ 0°

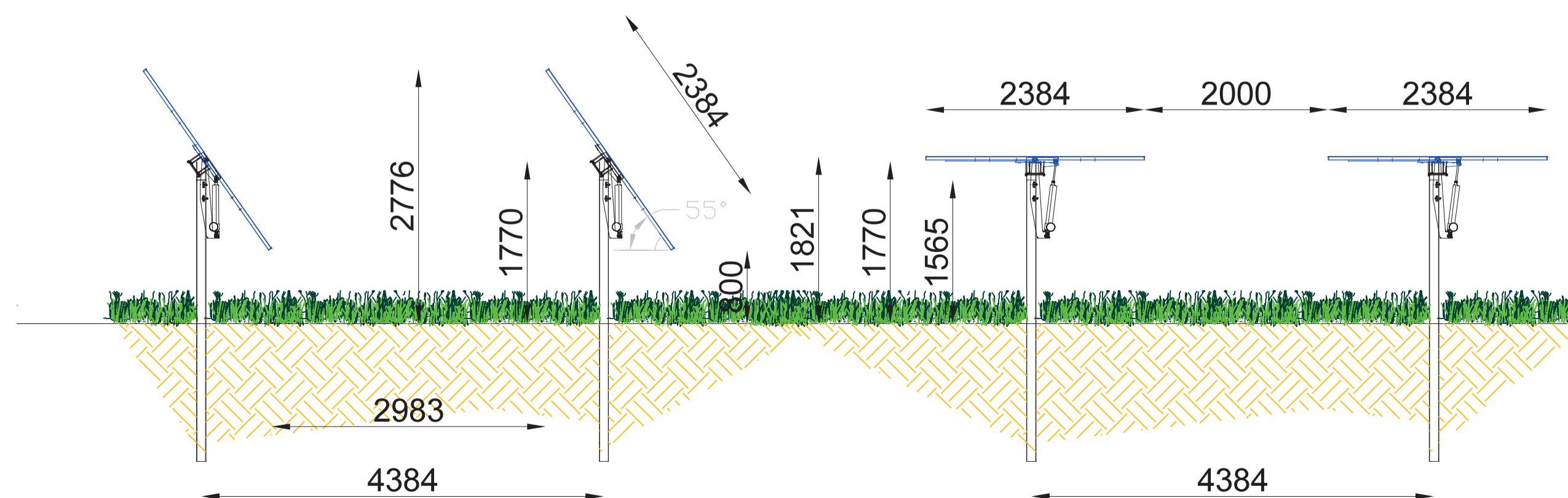

PV ICHNOSOLAR S.R.L.

Via Ettore de Sonnaz n. 19, 10121 Torino (TO) - Italy, P.I. 02379130517 - C.S. 10.000,00 i.v.
PEC pvichnosolar@pec.it
REA TO - 1293228

Impianto fotovoltaico "Macchiareddu" VALUTAZIONE DI IMPATTO AMBIENTALE



00	05/10/2021	Emissione	Gruppo di progettazione	Ing. Luca DEMONTIS	PV ICHNOSOLAR S.R.L.
REV.	DATA	OGGETTO	PREPARATO	CONTROLLATO	APPROVATO

GRUPPO DI PROGETTAZIONE: Ing. Luca DEMONTIS (coordinatore) Ing. Sandro CATTÀ	 ORDINE INGEGNERI PROVINCIA CAGLIARI N. 5099 Dott. Ing. LUCA DEMONTIS	Arch. Valeria MASALA (consulenza ambientale) Arch. Alessandro MURGIA (consulenza urbanistica) Geol. Alberto PUDDU (consulenza geologica) Dott. Agr. Marco ATZENI (consulenza agronomica) Dott. Agr. Sebastiano FALCONIO (consulenza agronomica)
--	---	---

TITOLO: STRUTTURE E MODULI (Tracker)	Fonte: Specifiche tecniche fornitore Misure espresse in centimetri.
IDENTIFICAZIONE ELABORATO Tav. 19	Nelle specifiche tecniche riportate di seguito sono stati disegnati i tracker con la minima distanza dal suolo, in posizione di massima inclinazione (h min 40 cm @ +/- 55°), prevista dal costruttore.
SCALA: varie	FORMATO: A1

Questo documento contiene informazioni di proprietà della PV ICHNOSOLAR S.R.L. e può essere utilizzato esclusivamente dall'assistente o relatore alla struttura per la quale è stato redatto. È vietata espressamente la ristampa o l'elaborazione senza l'esplicita autorizzazione della PV ICHNOSOLAR S.R.L.

TRJHT12PDP
FRONT VIEW @ 0°

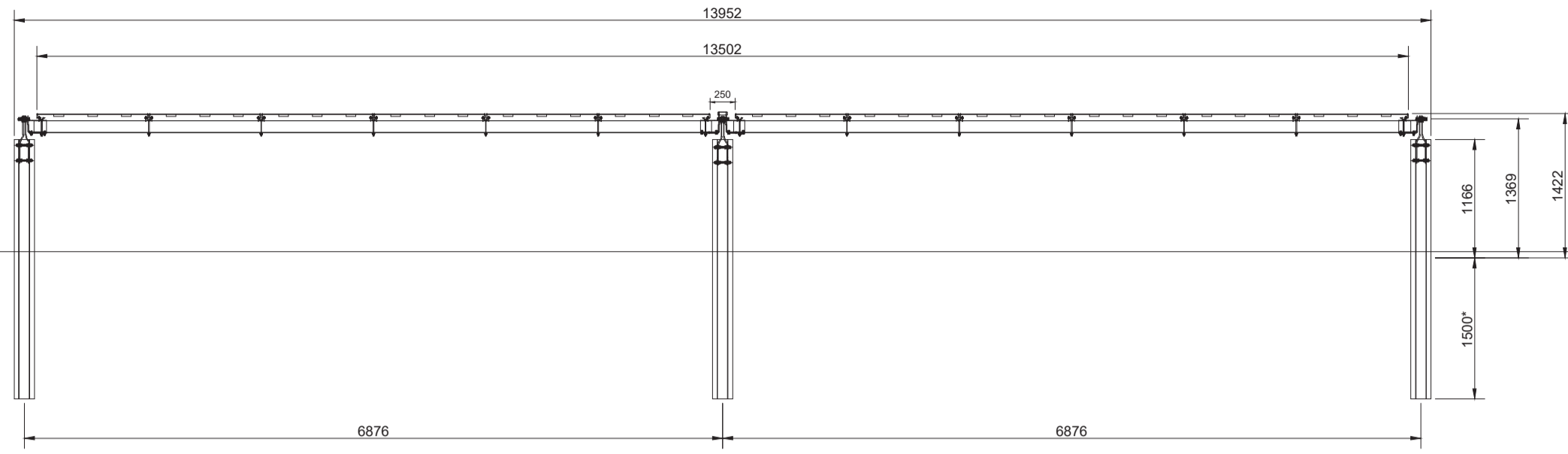

TRJHT12PDP
SIDE VIEW @ 0°

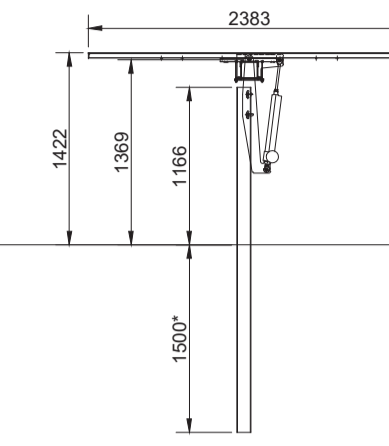

TRJHT12PDP
TOP VIEW @ 0°

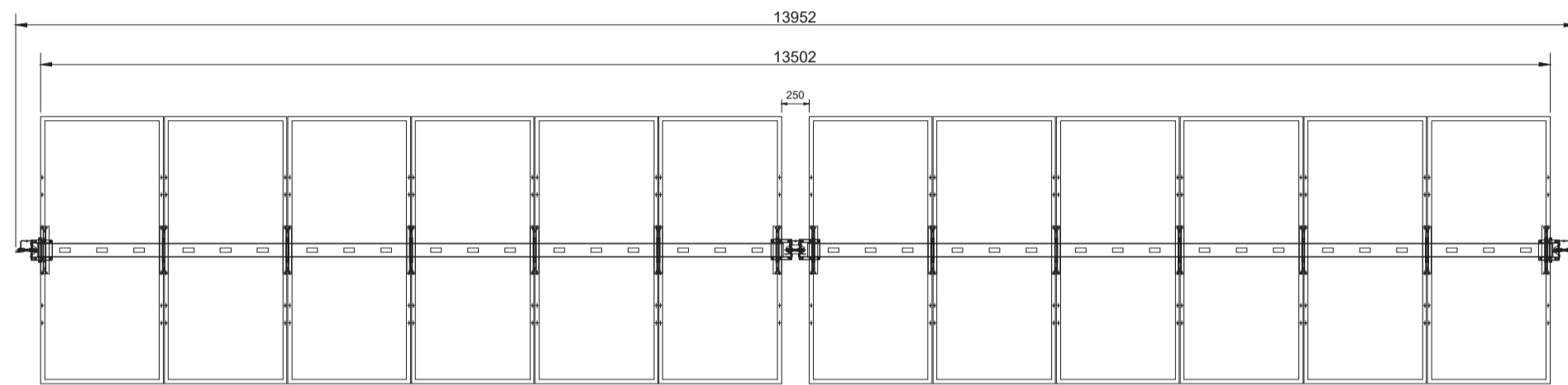

PHOTOVOLTAIC MODULE

Trina

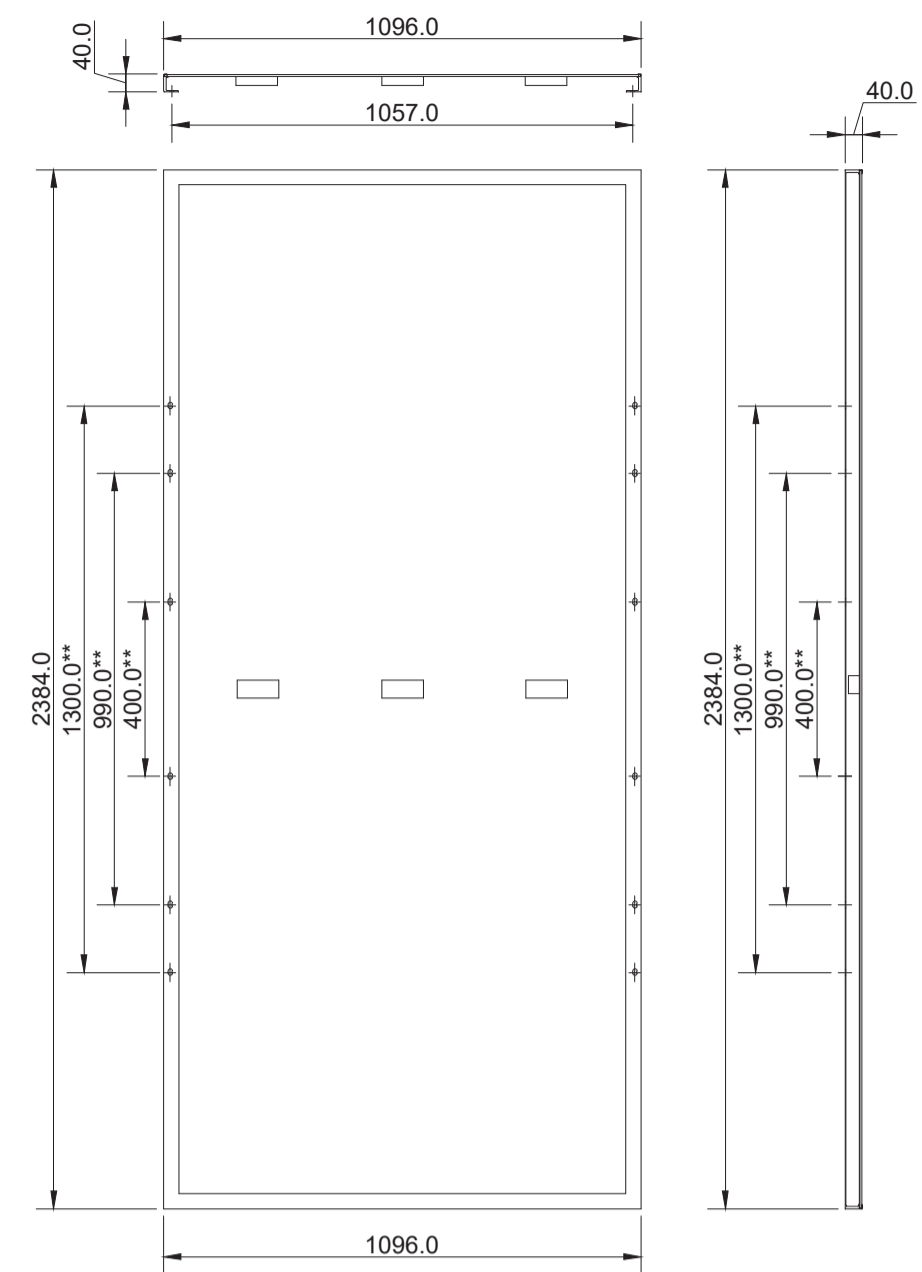

TORQUE TUBE & FIXING SECTION

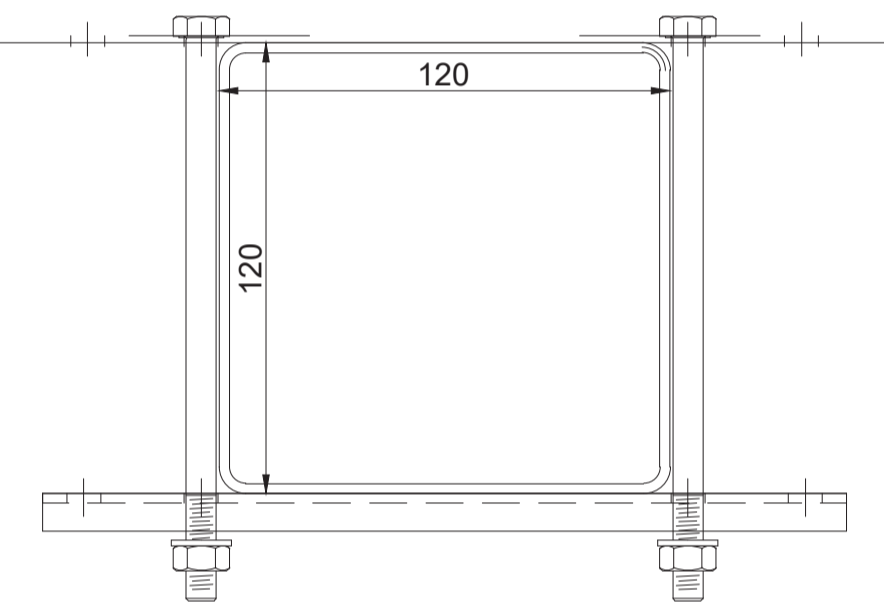

TRJHT12PDP
SIDE VIEW @ 55°

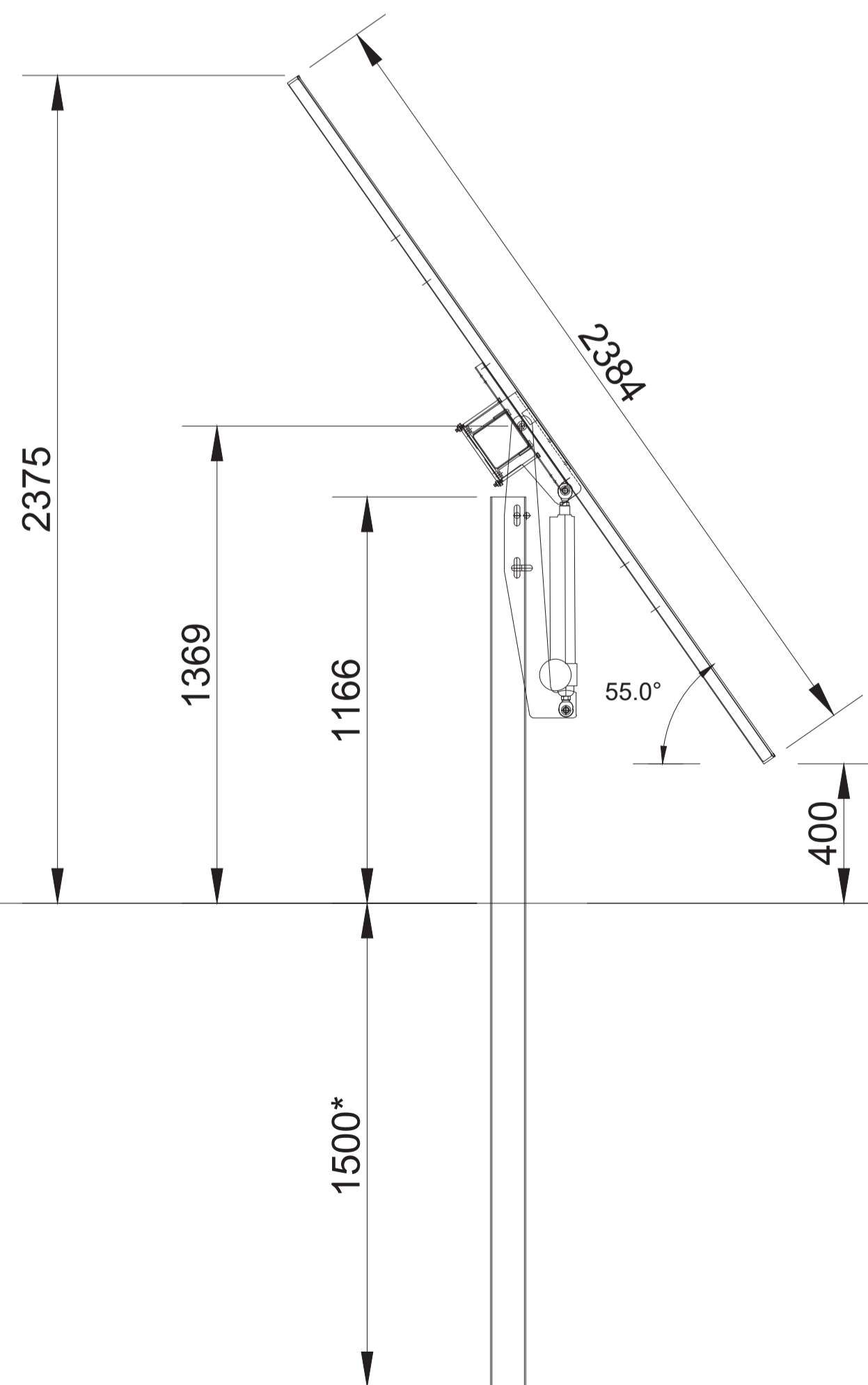

FOUNDATION TWIST ERROR RECOVERY

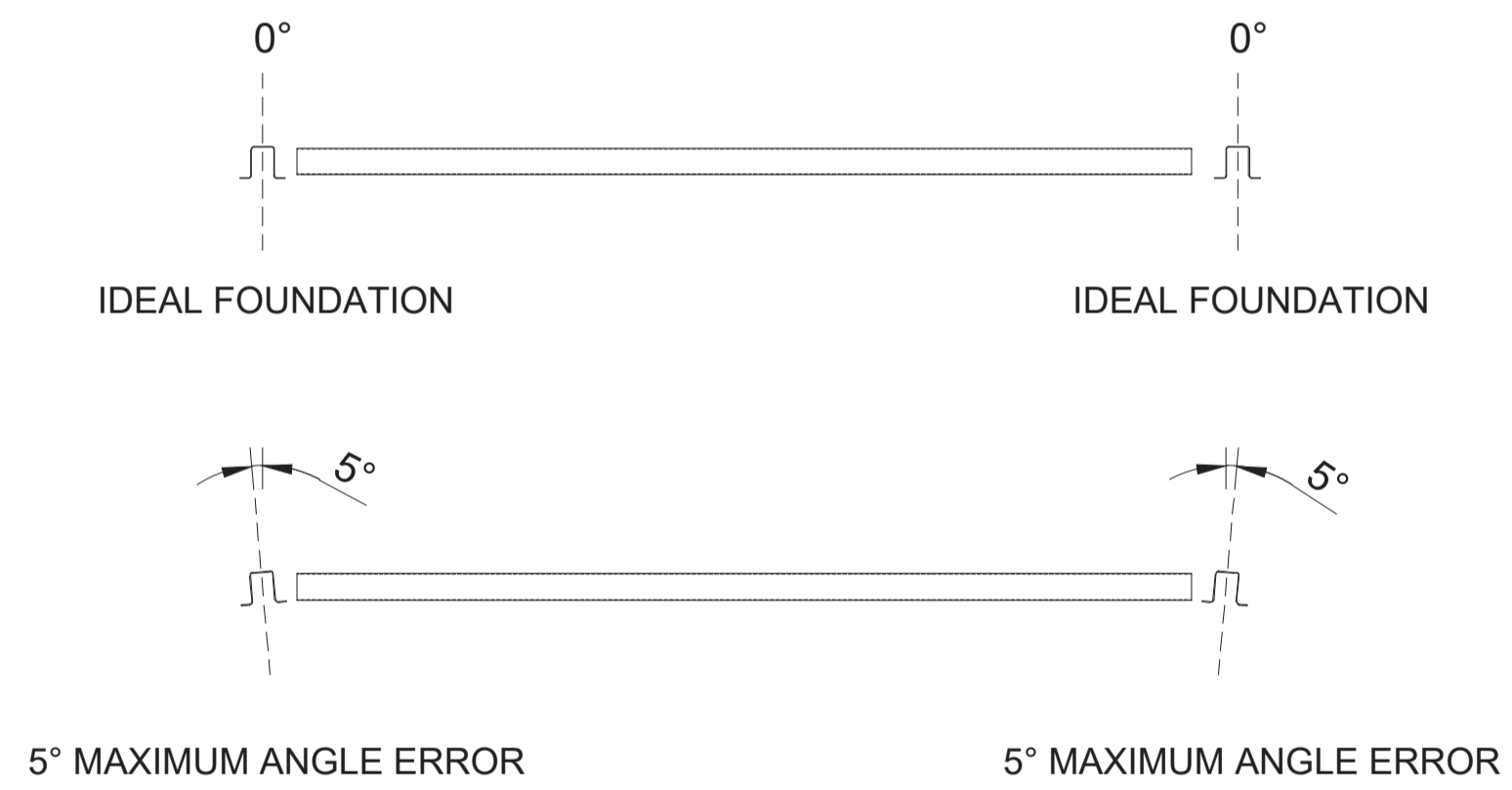

FOUNDATION ANGLE ERROR RECOVERY

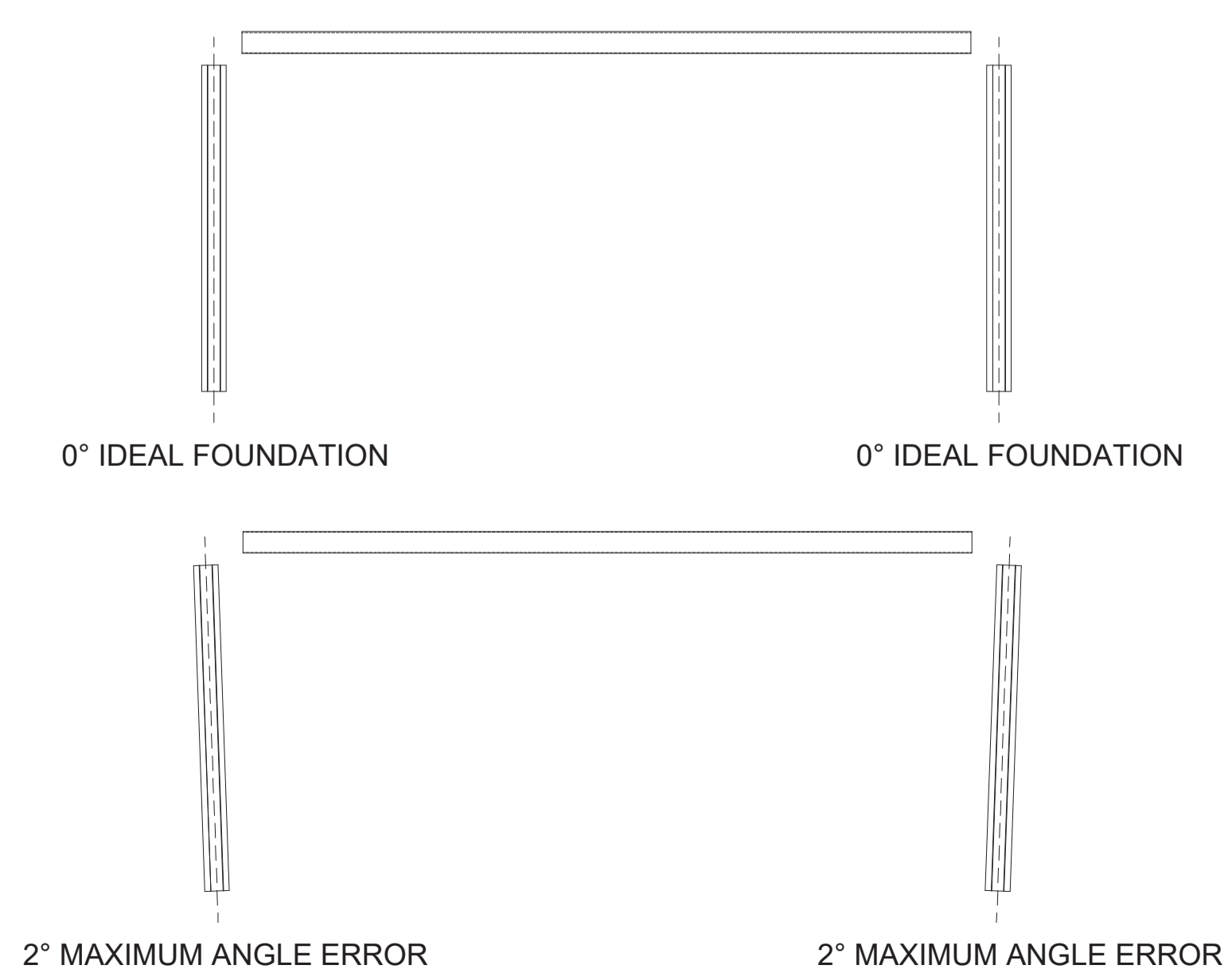

PRELIMINARY PV TABLES SPACING

NOMINAL VALUE - IT MAY CHANGE DUE TO MOUNTING TOLERANCES

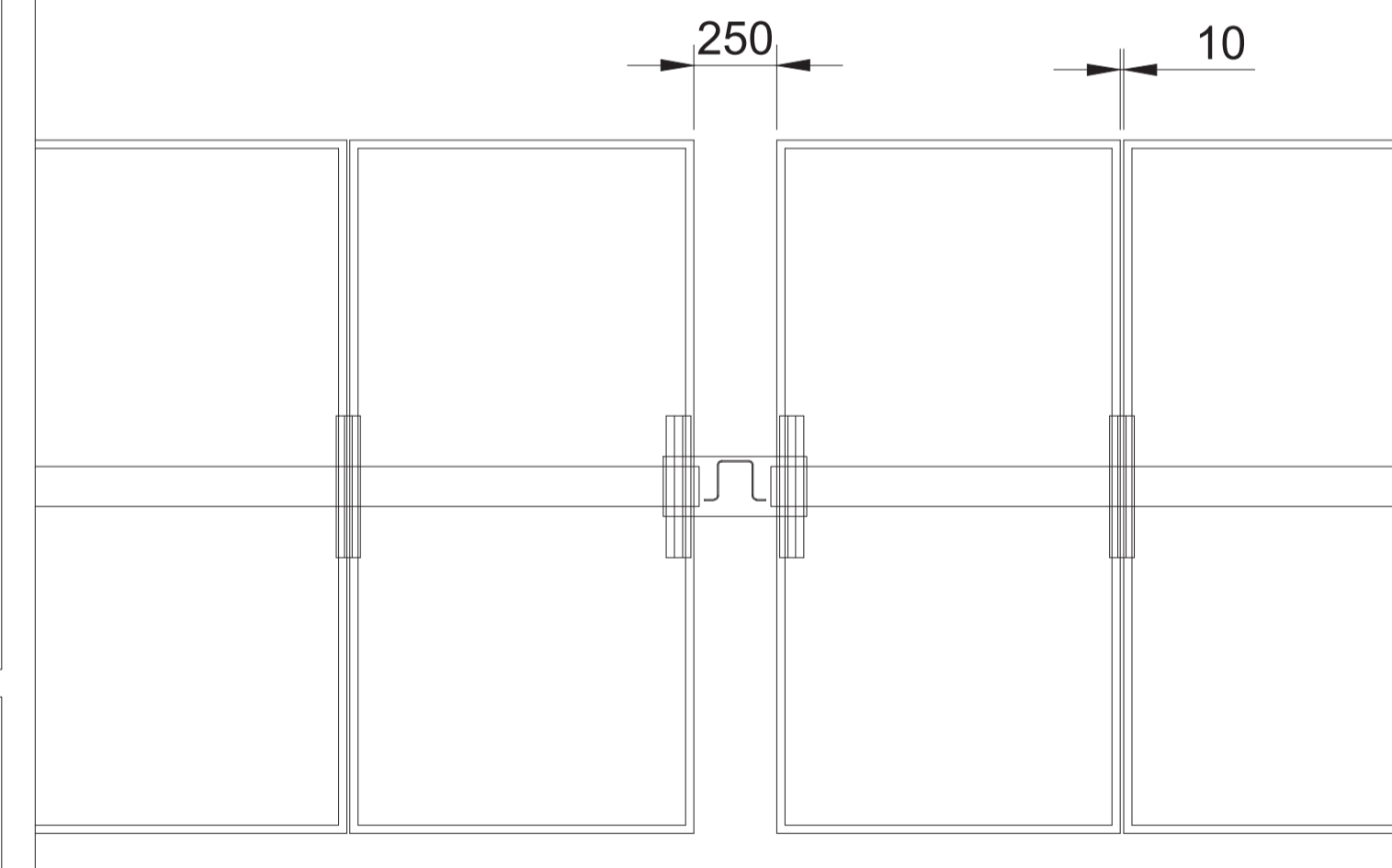

MATERIAL CHARACTERISTICS

- STEEL**
Structural steel - at least S235JR - yield strength and thickness in accordance with structural calculations.
- SPHERICAL BEARINGS**
Bronze / Stainless steel.
- SPACERS**
Stainless Steel.
- SCREWS, NUTS and WASHERS**
Hot dip galvanized according to ISO 1461:2009.
- GALVANIZATION**
Basic Option:
all equipments in steel hot dip galvanized according to ISO 1461:2009.
Optimization Option Pregalvanized Steel:
foundation posts and movement steel parts galvanized according to ISO 1461:2009 - Other steel parts pre-galvanized according to EN 10346 (Z275) or equivalent national standard.

The supplier reserves the right to change any particular before executive design release.

* Preliminary Value to be recalculated after geotechnical analysis and pull out tests.

** Preliminary Value to be confirmed after final PV module choice.

CONVERT ITALIA SpA

PROJECT DESCRIPTION

TRJHT12PDP

CLIENT

PV Ichnosolar S.r.l.

STATE PROJECT

Preliminary Drawing

RAPPRESENTATION

**Annex 1
General Assembly Drawing**

REFERENCE DRAWING	NUMBER PROJECT	DATE EMISSION	FORMAT DRAWING
		SCALE:	SCALE DWG:

REV.	DATE	DESCRIPTION	DESIGNED	CHECKED	APPROVED

TRJHT18PDP
FRONT VIEW @ 0°

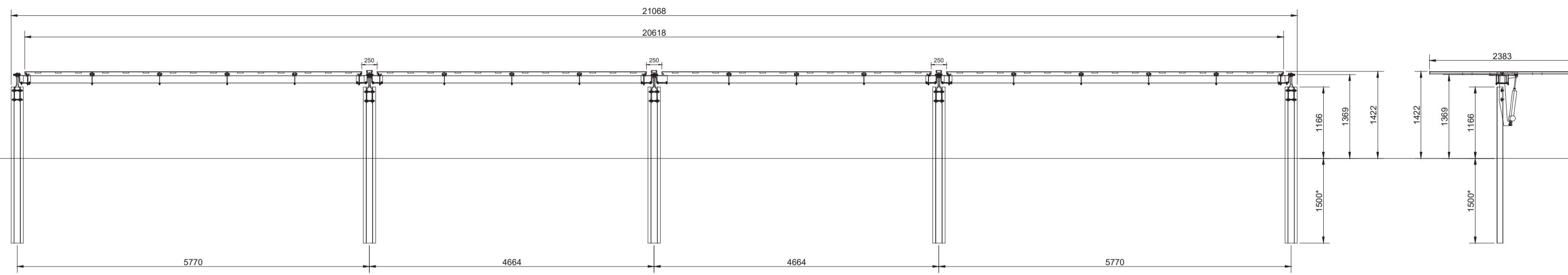

TRJHT18PDP
SIDE VIEW @ 0°

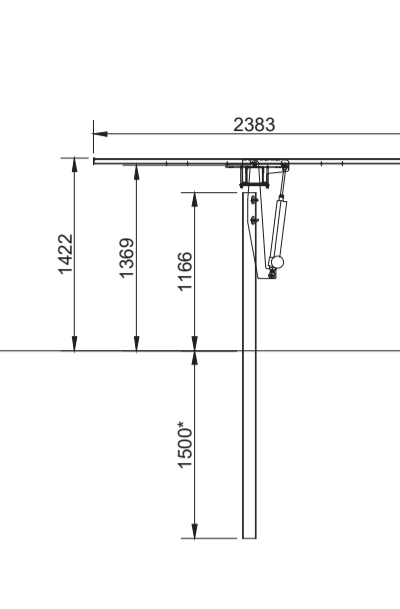

TRJHT18PDP
TOP VIEW @ 0°

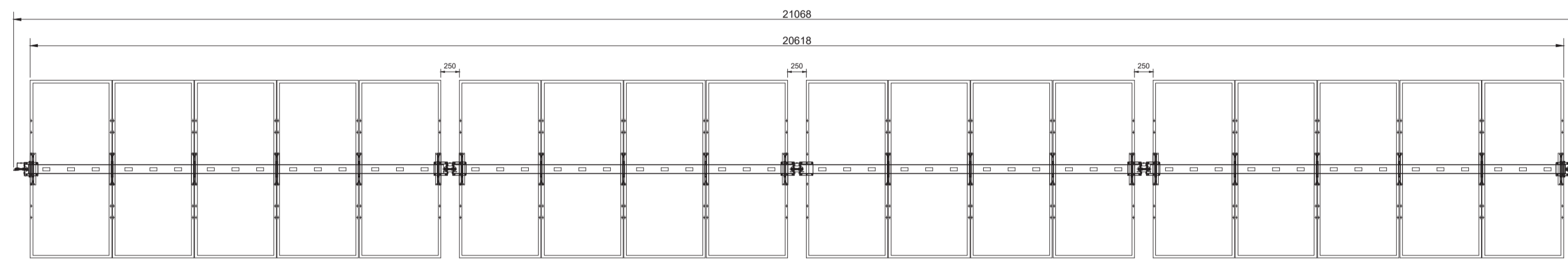

PHOTOVOLTAIC MODULE

Trina

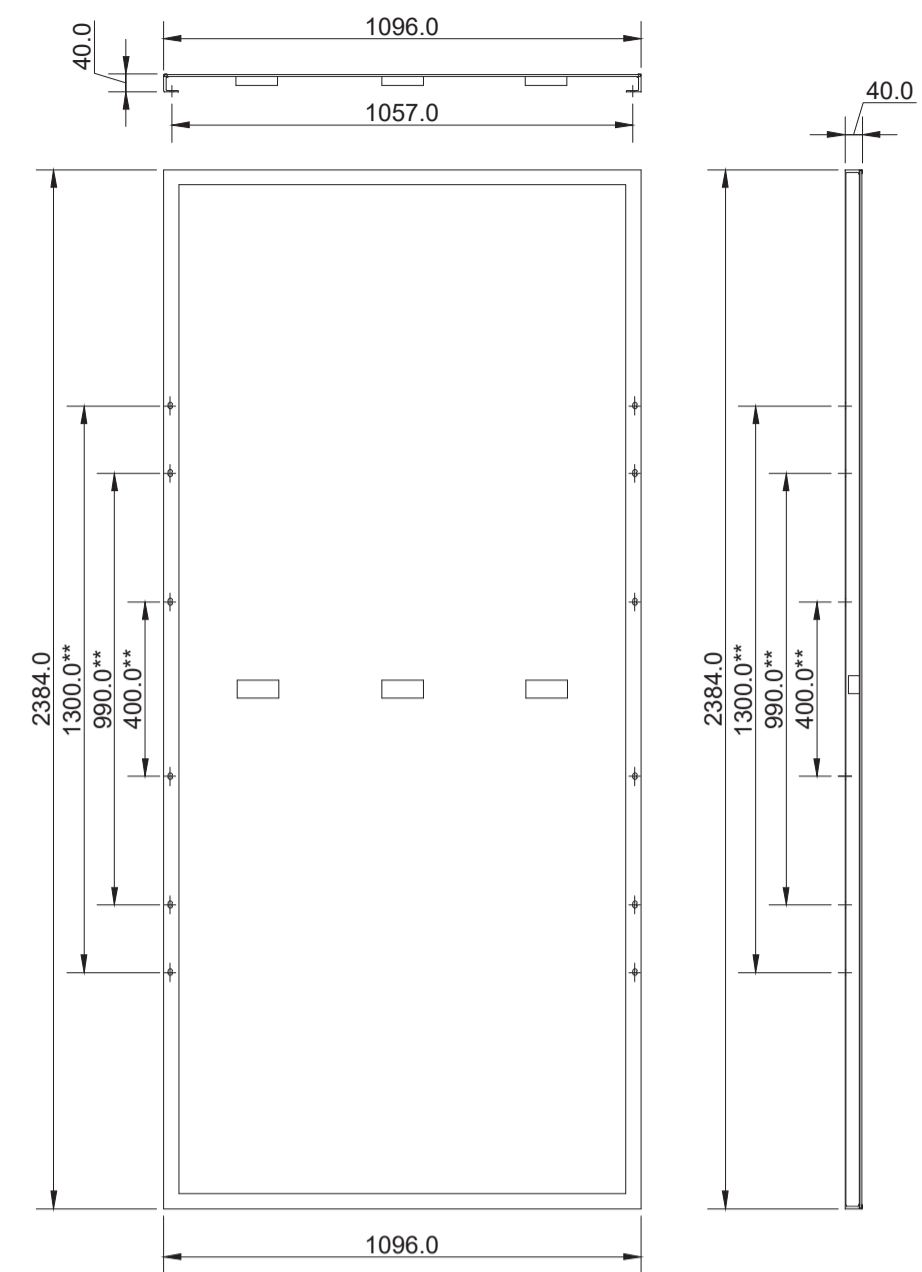

TORQUE TUBE & FIXING SECTION

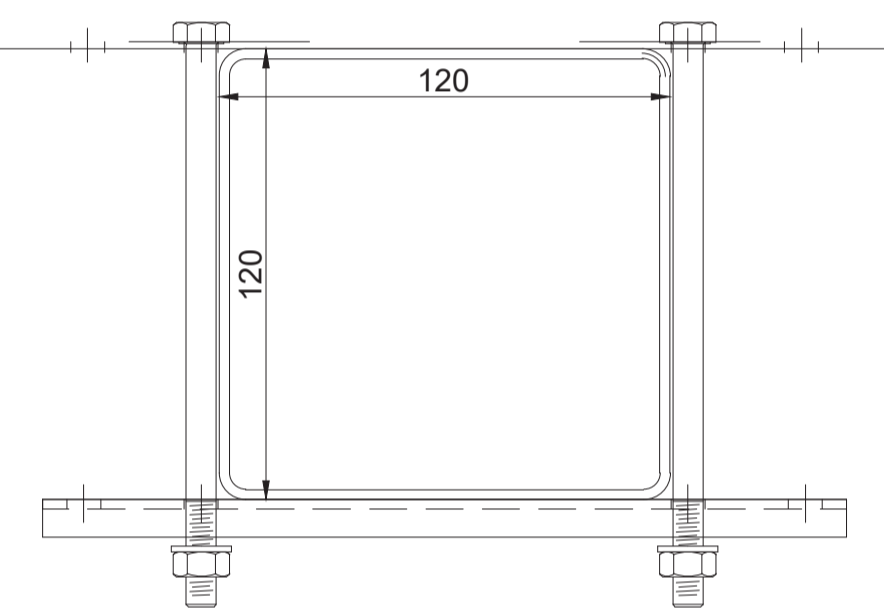

TRJHT18PDP
SIDE VIEW @ 55°

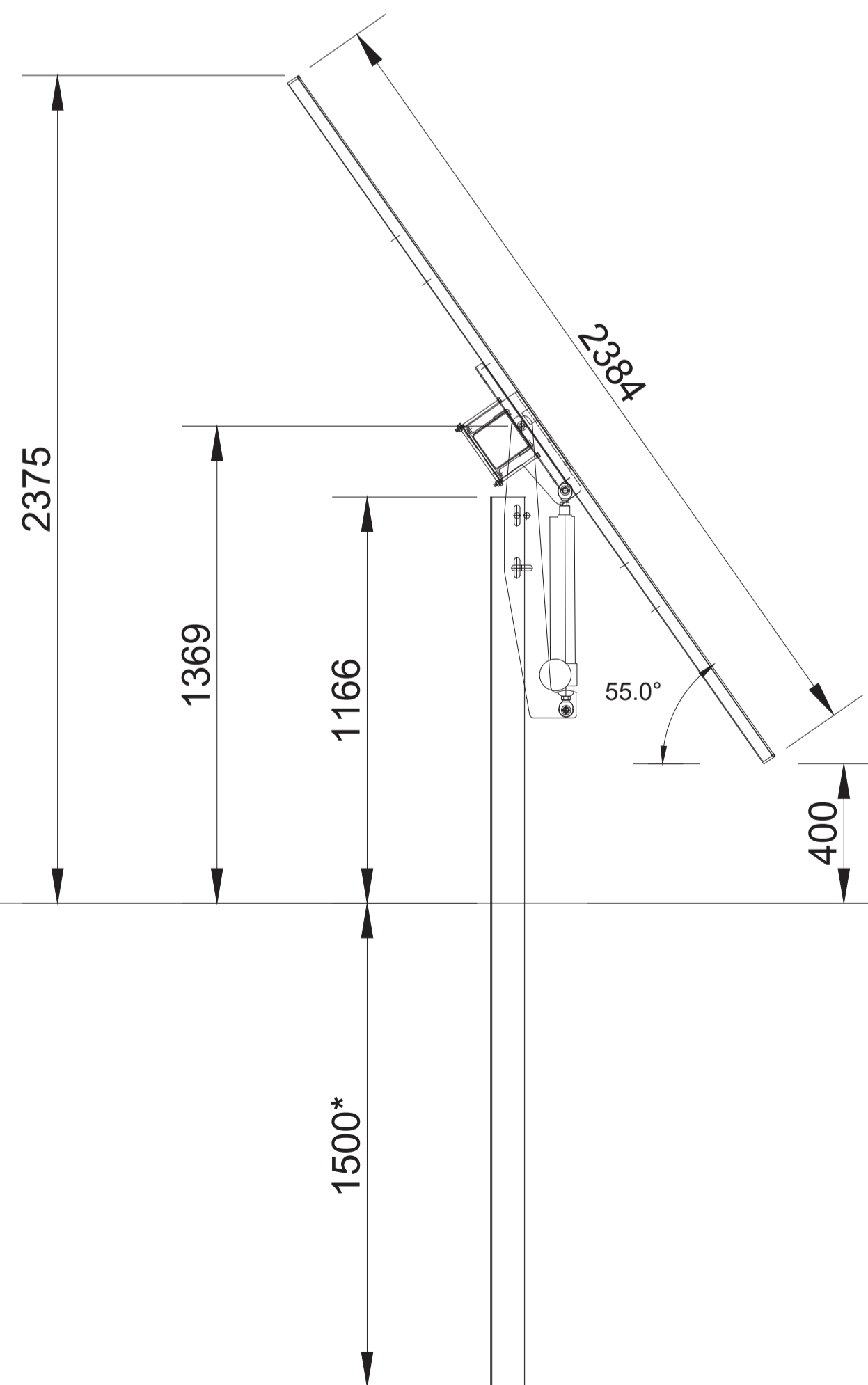

FOUNDATION TWIST ERROR RECOVERY

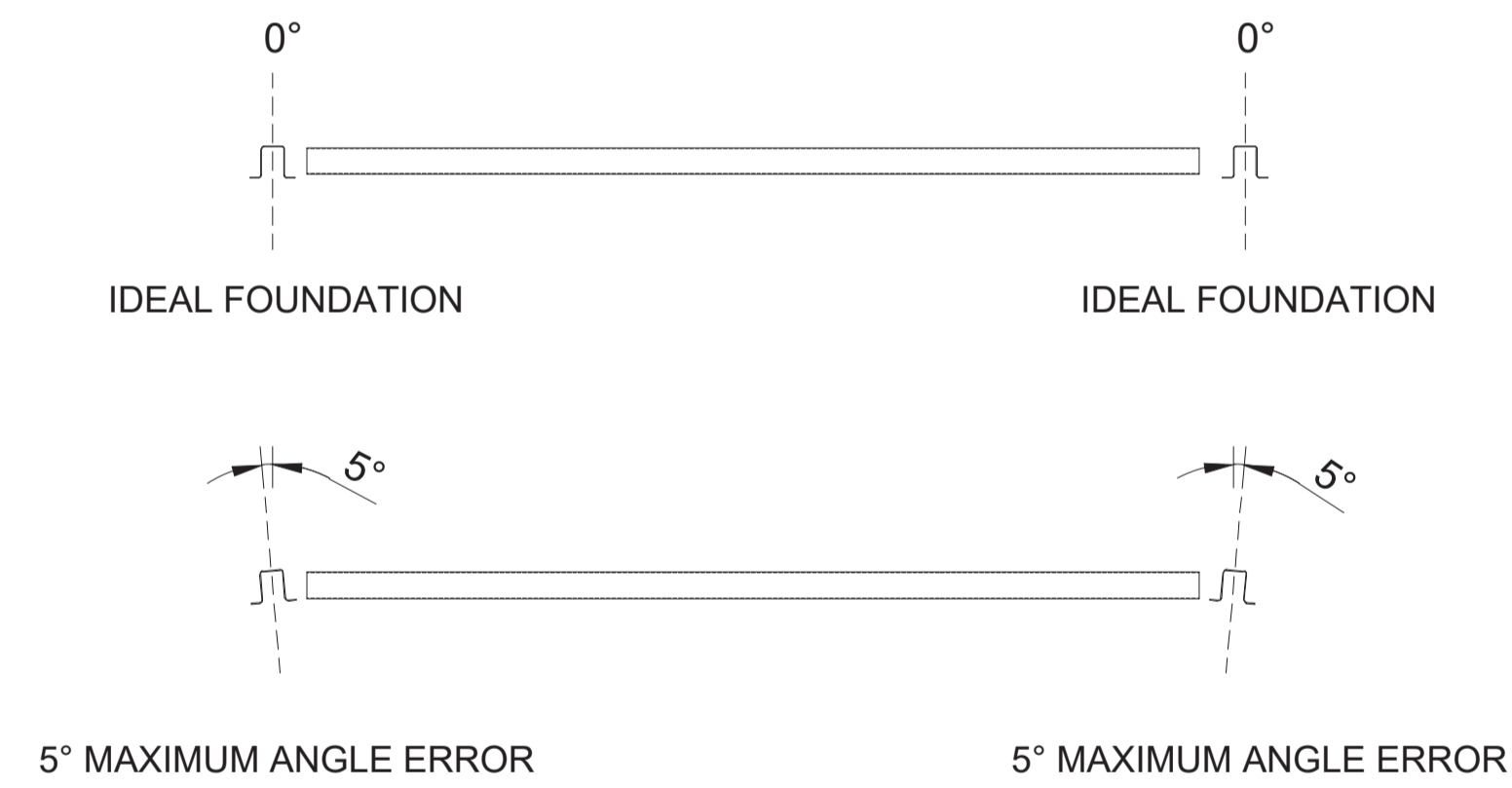

PRELIMINARY PV TABLES SPACING

NOMINAL VALUE - IT MAY CHANGE DUE TO MOUNTING TOLERANCES

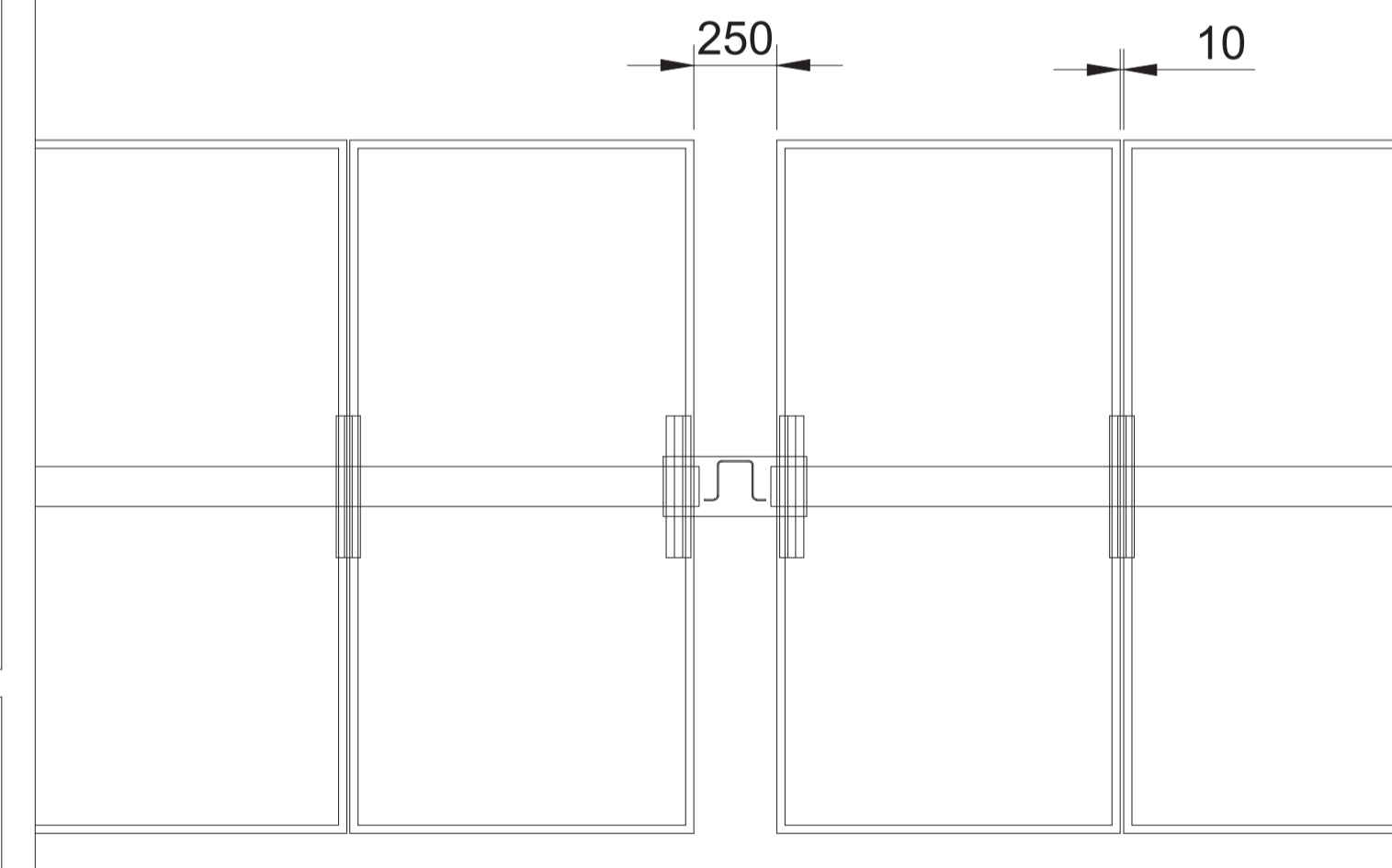

FOUNDATION ANGLE ERROR RECOVERY

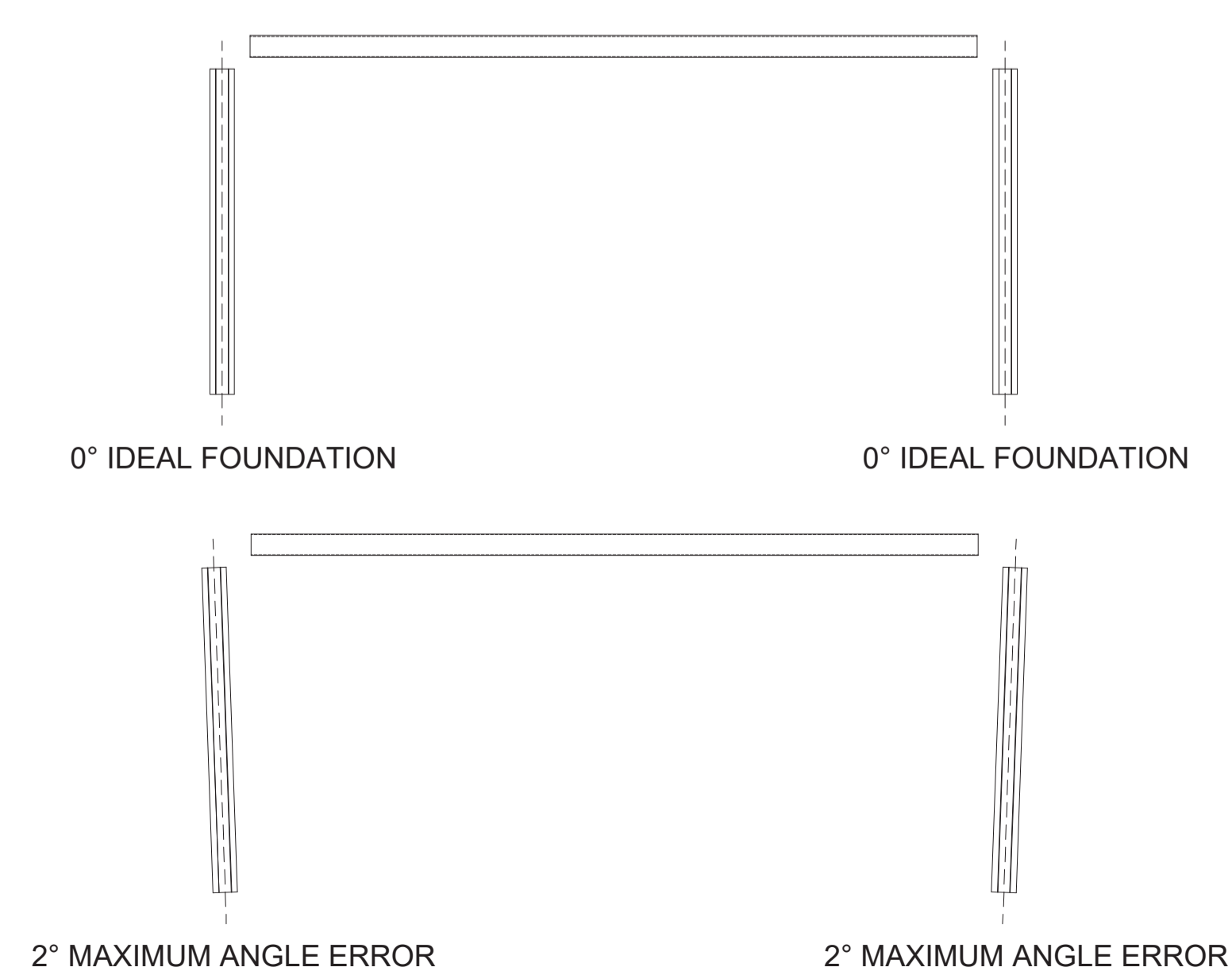

MATERIAL CHARACTERISTICS

STEEL

Structural steel - at least S235JR - yield strength and thickness in accordance with structural calculations.

SPHERICAL BEARINGS

Bronze / Stainless steel.

SPACERS

Stainless Steel.

SCREWS, NUTS and WASHERS

Hot dip galvanized according to ISO 1461:2009.

GALVANIZATION

Basic Option:
all equipments in steel hot dip galvanized according to ISO 1461:2009.

Optimization Option Pregalvanized Steel:

foundation posts and movement steel parts galvanized according to ISO 1461:2009 - Other steel parts pre-galvanized according to EN 10346 (Z275) or equivalent national standard.

The supplier reserves the right to change any particular before executive design release.

* Preliminary Value to be recalculated after geotechnical analysis and pull out tests.

** Preliminary Value to be confirmed after final PV module choice.

CONVERT ITALIA SpA

PROJECT DESCRIPTION

TRJHT18PDP

CLIENT

PV Ichnosolar S.r.l.

STATE PROJECT

Preliminary Drawing

RAPPRESENTATION

**Annex 1
General Assembly Drawing**

REFERENCE DRAWING	NUMBER PROJECT	DATE EMISSION	FORMAT DRAWING
		SCALE:	SCALE DWG:

REV.	DATE	DESCRIPTION	DESIGNED	CHECKED	APPROVED

TRJHT36PDP
FRONT VIEW @ 0°

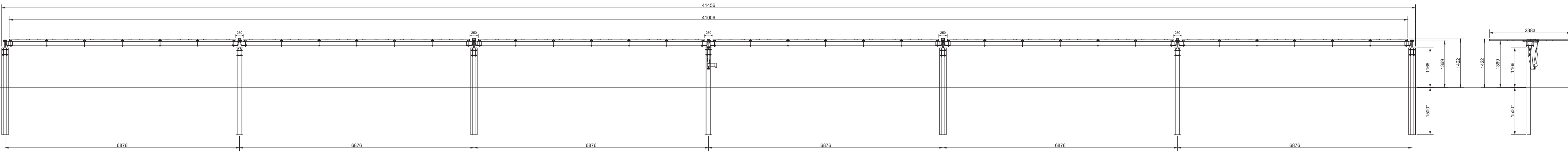

TRJHT36PDP
SIDE VIEW @ 0°

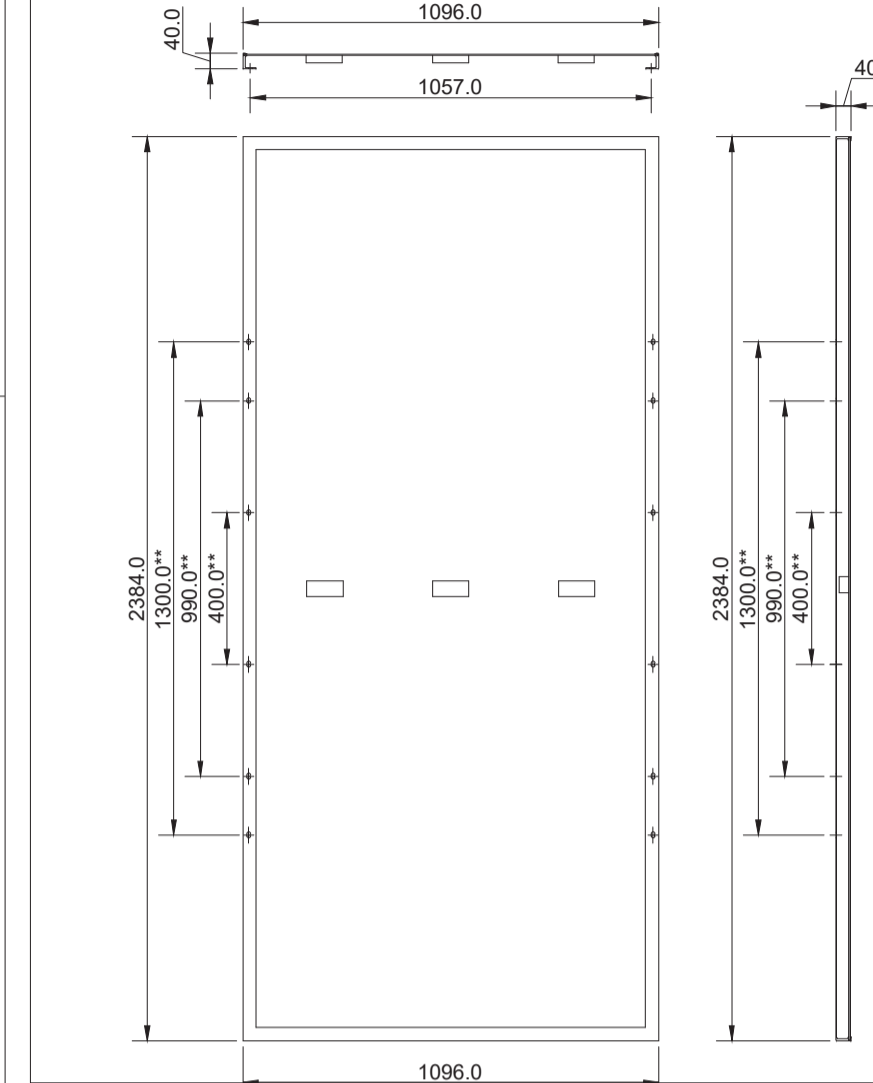

TRJHT36PDP
TOP VIEW @ 0°

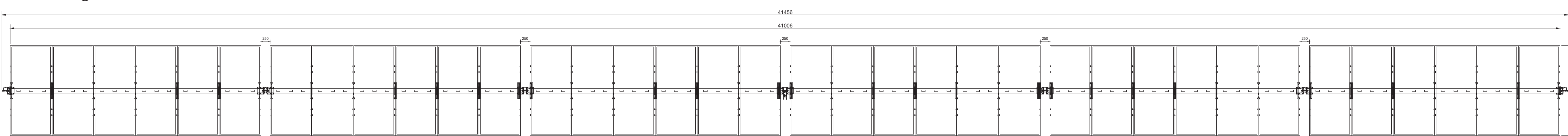

PHOTOVOLTAIC MODULE

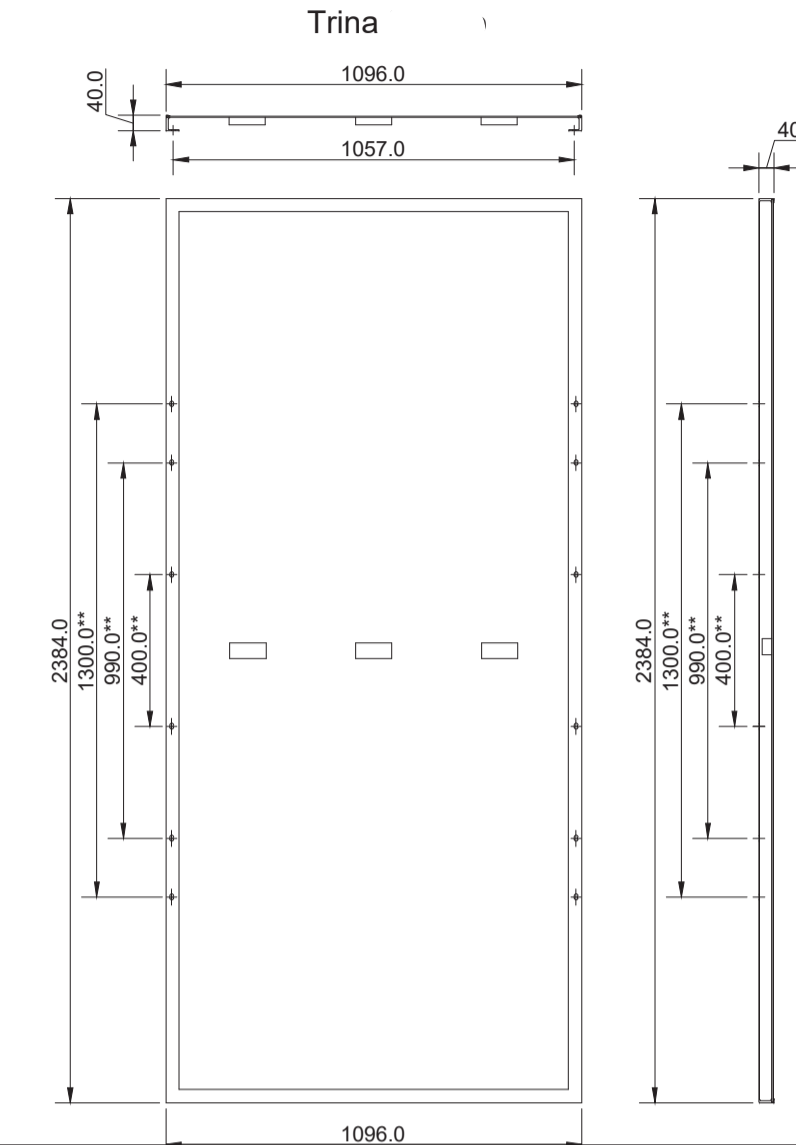

TORQUE TUBE & FIXING SECTION

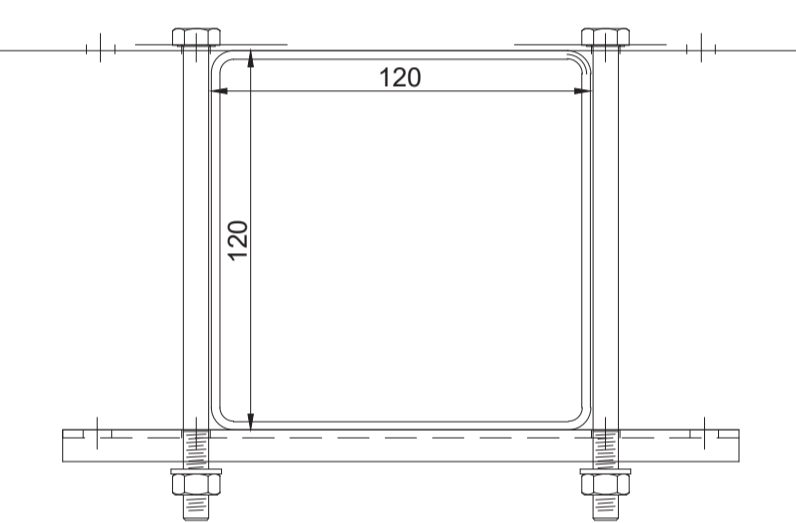

The supplier reserves the right to change any particular before executive design release.

* Preliminary Value to be recalculated after geotechnical analysis and pull out tests.

** Preliminary Value to be confirmed after final PV module choice.

TRJHT36PDP
SIDE VIEW @ 55°

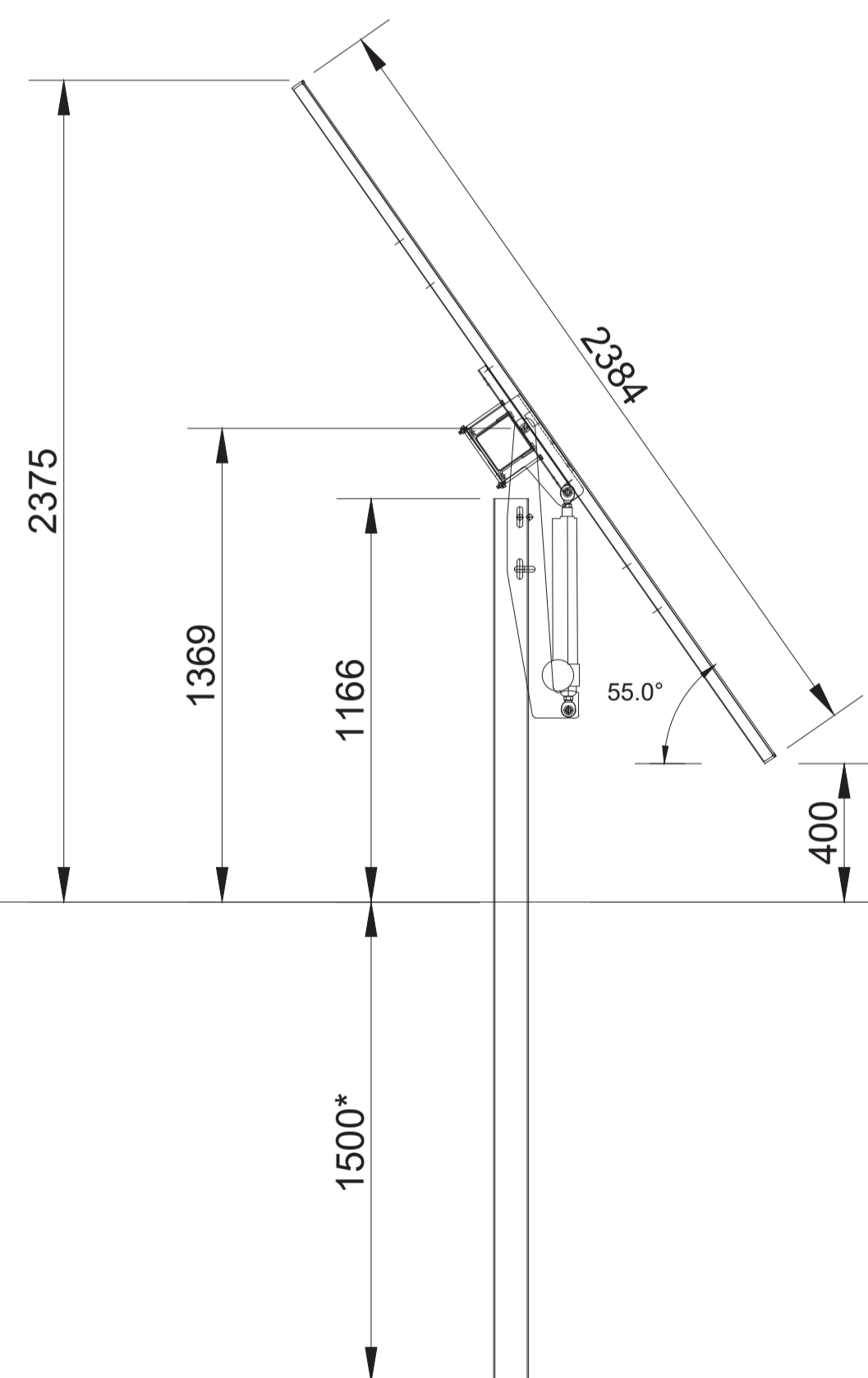

FOUNDATION TWIST ERROR RECOVERY

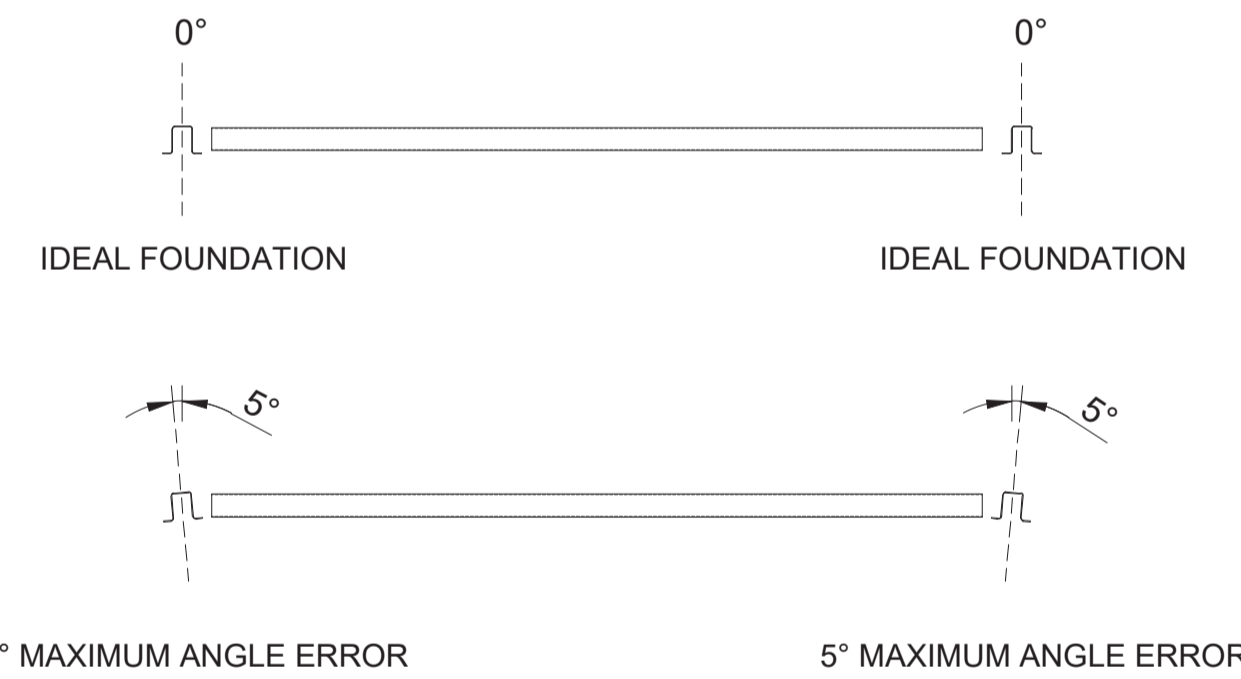

FOUNDATION ANGLE ERROR RECOVERY

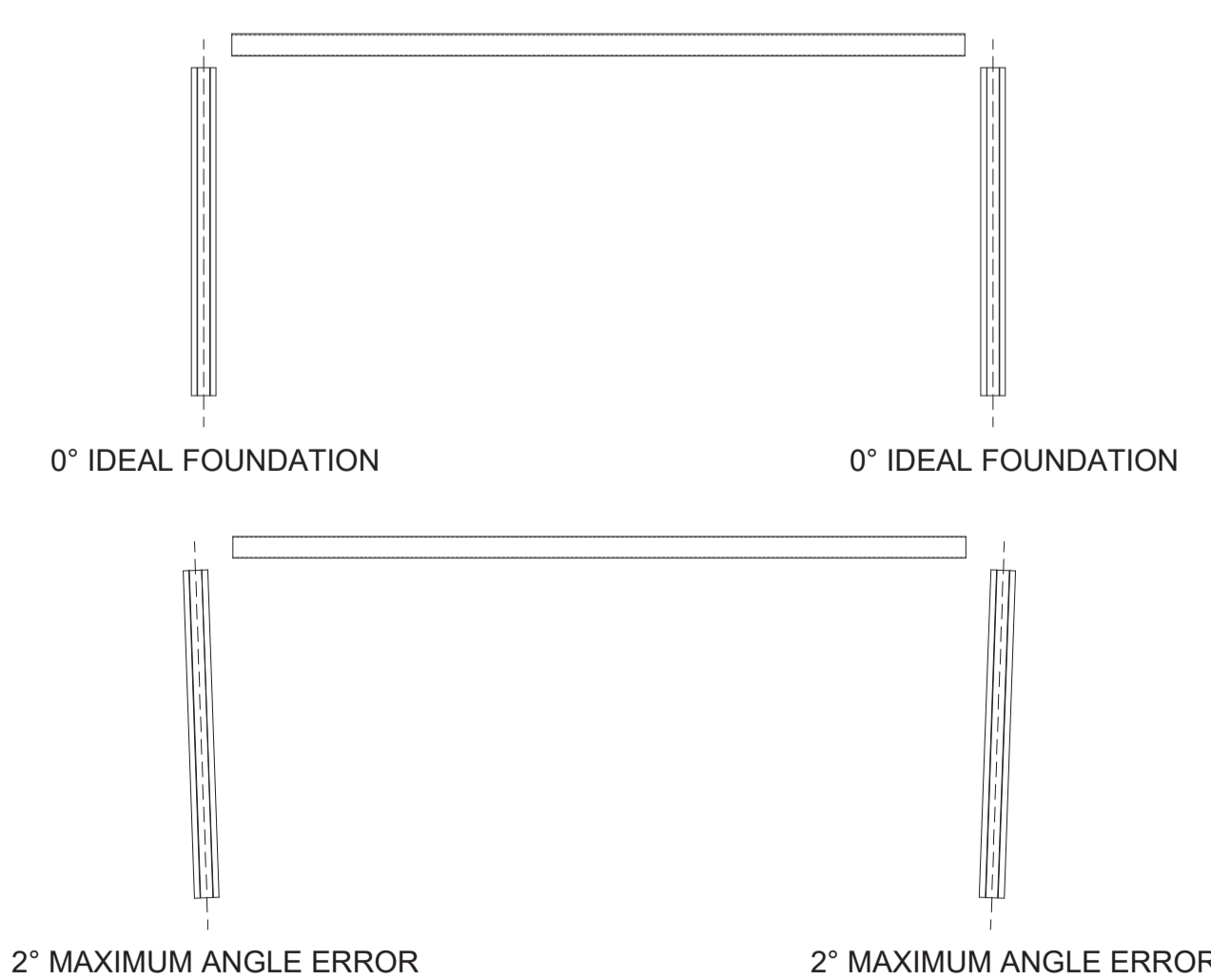

PRELIMINARY PV TABLES SPACING

NOMINAL VALUE - IT MAY CHANGE DUE TO MOUNTING TOLERANCES

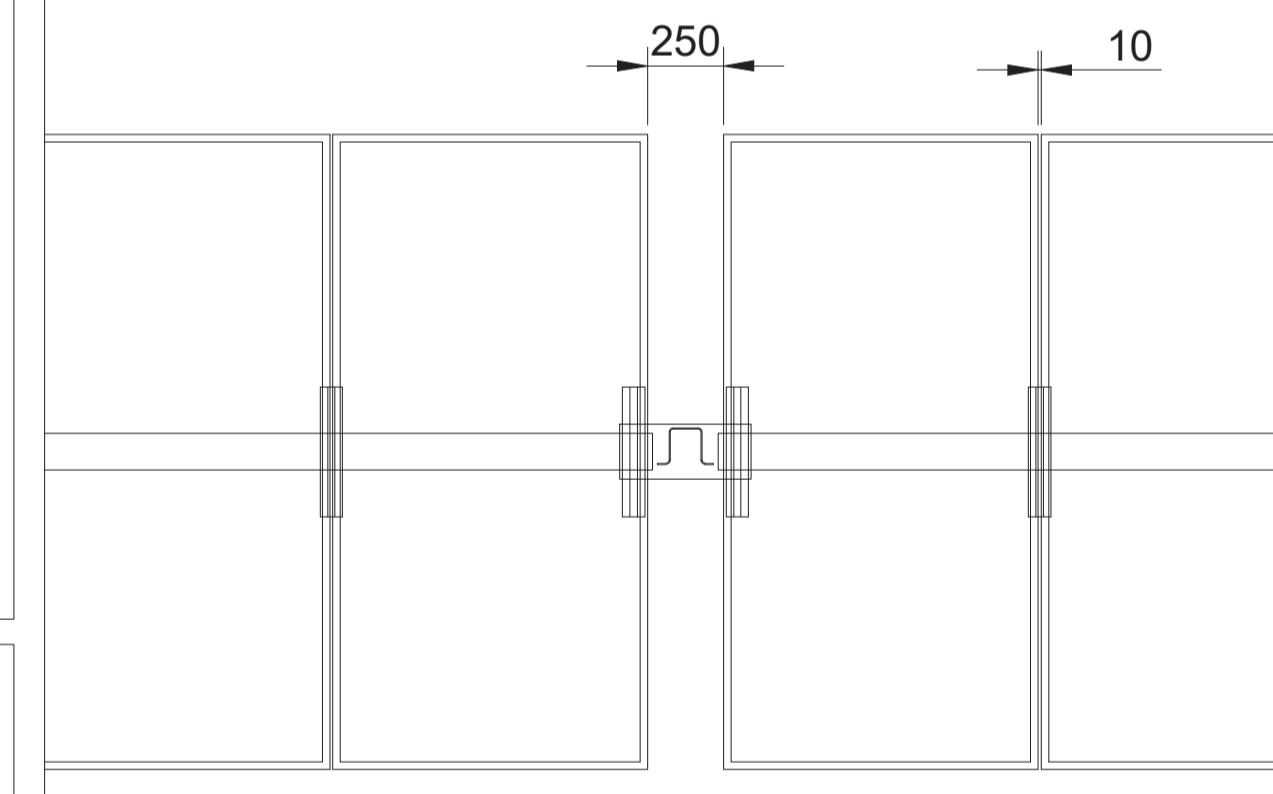

MATERIAL CHARACTERISTICS

STEEL
Structural steel - at least S235JR - yield strength and thickness in accordance with structural calculations.

SPHERICAL BEARINGS
Bronze / Stainless steel.

SPACERS
Stainless Steel.

SCREWS, NUTS and WASHERS
Hot dip galvanized according to ISO 1461:2009.

GALVANIZATION
Basic Option:
all equipments in steel hot dip galvanized according to ISO 1461:2009.
Optimization Option Pregalvanized Steel:
foundation posts and movement steel parts galvanized according to ISO 1461:2009 - Other steel parts pre-galvanized according to EN 10346 (Z275) or equivalent national standard.

CONVERT ITALIA SpA

PROJECT DESCRIPTION

TRJHT36PDP

CLIENT

PV Ichnosolar S.r.l.

STATE PROJECT

Preliminary Drawing

REPRESENTATION

**Annex 1
General Assembly Drawing**

REVISION	NUMBER	PROJECT	DATE DESIGN	FORMAT DRAWING

REV.	DATE	DESCRIPTION	DESIGNED	CHECKED	APPROVED

DESIGN

© COPYRIGHT Convert Italia S.p.A.
All rights reserved.
As provided by law, this document is the property of CONVERT ITALIA S.p.A. any reproduction or transmission to third parties without our written authorization is prohibited.