

**PROGETTO DI IMPIANTO FOTOVOLTAICO IN LOCALITA' LEVADA
NEL COMUNE DI CONCORDIA SAGITTARIA (VE)**

Procedimento di Valutazione di Impatto Ambientale ai sensi dell'art.23 del D.Lgs.152/2006 e ss.mm.ii.

Procedura abilitativa semplificata e comunicazione per gli impianti alimentati da energia rinnovabile
Impianti FOTOVOLTAICI DI POTENZA INFERIORE A 20 MW Art. 6, d.lgs. 28 del 3.03.2011
(rif. modifica Legge 108 del 29.07.2021)

GRUPPO DI PROGETTAZIONE

Capellino
Studio di Ingegneria

STUDIO DI INGEGNERIA

Dot. Ing. ANTONIO CAPELLINO

iscritto all'ordine degli Ingegneri di Cuneo al n° A647

Corso Armando Diaz, 23/1

12084 Mondovì - (CN)

☎ 0174/551247

✉ info@studiocapellino.it

✉ antonio.capellino@ingpec.eu

Dot. Arch. DANIELE BORINA S.S. 28 anni, 41 - 12084 Mondovì (CN) # 0174/551247

Dot. Arch. ALBERTO BORGHESE S.S. 28 anni, 41 - 12084 Mondovì (CN) # 0174/551247

Dot. Arch. NIKO GARELLI S.S. 28 anni, 41 - 12084 Mondovì (CN) # 0174/551247

Dot. Arch. ALBERTO BORGHESE S.S. 28 anni, 41 - 12084 Mondovì (CN) # 0174/551247

Dot. Arch. DANIELE BORINA S.S. 28 anni, 41 - 12084 Mondovì (CN) # 0174/551247

Dot. Arch. NIKO GARELLI S.S. 28 anni, 41 - 12084 Mondovì (CN) # 0174/551247

Dot. Arch. DANIELE BORINA S.S. 28 anni, 41 - 12084 Mondovì (CN) # 0174/551247

Dot. Arch. NIKO GARELLI S.S. 28 anni, 41 - 12084 Mondovì (CN) # 0174/551247

Dot. Arch. DANIELE BORINA S.S. 28 anni, 41 - 12084 Mondovì (CN) # 0174/551247

Dot. Arch. NIKO GARELLI S.S. 28 anni, 41 - 12084 Mondovì (CN) # 0174/551247

Dot. Arch. DANIELE BORINA S.S. 28 anni, 41 - 12084 Mondovì (CN) # 0174/551247

Dot. Arch. NIKO GARELLI S.S. 28 anni, 41 - 12084 Mondovì (CN) # 0174/551247

Dot. Arch. DANIELE BORINA S.S. 28 anni, 41 - 12084 Mondovì (CN) # 0174/551247

Dot. Arch. NIKO GARELLI S.S. 28 anni, 41 - 12084 Mondovì (CN) # 0174/551247

Dot. Arch. DANIELE BORINA S.S. 28 anni, 41 - 12084 Mondovì (CN) # 0174/551247

Dot. Arch. NIKO GARELLI S.S. 28 anni, 41 - 12084 Mondovì (CN) # 0174/551247

Dot. Arch. DANIELE BORINA S.S. 28 anni, 41 - 12084 Mondovì (CN) # 0174/551247

Dot. Arch. NIKO GARELLI S.S. 28 anni, 41 - 12084 Mondovì (CN) # 0174/551247

Dot. Arch. DANIELE BORINA S.S. 28 anni, 41 - 12084 Mondovì (CN) # 0174/551247

Dot. Arch. NIKO GARELLI S.S. 28 anni, 41 - 12084 Mondovì (CN) # 0174/551247

Dot. Arch. DANIELE BORINA S.S. 28 anni, 41 - 12084 Mondovì (CN) # 0174/551247

Dot. Arch. NIKO GARELLI S.S. 28 anni, 41 - 12084 Mondovì (CN) # 0174/551247

Dot. Arch. DANIELE BORINA S.S. 28 anni, 41 - 12084 Mondovì (CN) # 0174/551247

Dot. Arch. NIKO GARELLI S.S. 28 anni, 41 - 12084 Mondovì (CN) # 0174/551247

Dot. Arch. DANIELE BORINA S.S. 28 anni, 41 - 12084 Mondovì (CN) # 0174/551247

Dot. Arch. NIKO GARELLI S.S. 28 anni, 41 - 12084 Mondovì (CN) # 0174/551247

Dot. Arch. DANIELE BORINA S.S. 28 anni, 41 - 12084 Mondovì (CN) # 0174/551247

Dot. Arch. NIKO GARELLI S.S. 28 anni, 41 - 12084 Mondovì (CN) # 0174/551247

Dot. Arch. DANIELE BORINA S.S. 28 anni, 41 - 12084 Mondovì (CN) # 0174/551247

Dot. Arch. NIKO GARELLI S.S. 28 anni, 41 - 12084 Mondovì (CN) # 0174/551247

Dot. Arch. DANIELE BORINA S.S. 28 anni, 41 - 12084 Mondovì (CN) # 0174/551247

Dot. Arch. NIKO GARELLI S.S. 28 anni, 41 - 12084 Mondovì (CN) # 0174/551247

Dot. Arch. DANIELE BORINA S.S. 28 anni, 41 - 12084 Mondovì (CN) # 0174/551247

Dot. Arch. NIKO GARELLI S.S. 28 anni, 41 - 12084 Mondovì (CN) # 0174/551247

Dot. Arch. DANIELE BORINA S.S. 28 anni, 41 - 12084 Mondovì (CN) # 0174/551247

Dot. Arch. NIKO GARELLI S.S. 28 anni, 41 - 12084 Mondovì (CN) # 0174/551247

Dot. Arch. DANIELE BORINA S.S. 28 anni, 41 - 12084 Mondovì (CN) # 0174/551247

Dot. Arch. NIKO GARELLI S.S. 28 anni, 41 - 12084 Mondovì (CN) # 0174/551247

Dot. Arch. DANIELE BORINA S.S. 28 anni, 41 - 12084 Mondovì (CN) # 0174/551247

Dot. Arch. NIKO GARELLI S.S. 28 anni, 41 - 12084 Mondovì (CN) # 0174/551247

Dot. Arch. DANIELE BORINA S.S. 28 anni, 41 - 12084 Mondovì (CN) # 0174/551247

Dot. Arch. NIKO GARELLI S.S. 28 anni, 41 - 12084 Mondovì (CN) # 0174/551247

Dot. Arch. DANIELE BORINA S.S. 28 anni, 41 - 12084 Mondovì (CN) # 0174/551247

Dot. Arch. NIKO GARELLI S.S. 28 anni, 41 - 12084 Mondovì (CN) # 0174/551247

Dot. Arch. DANIELE BORINA S.S. 28 anni, 41 - 12084 Mondovì (CN) # 0174/551247

Dot. Arch. NIKO GARELLI S.S. 28 anni, 41 - 12084 Mondovì (CN) # 0174/551247

Dot. Arch. DANIELE BORINA S.S. 28 anni, 41 - 12084 Mondovì (CN) # 0174/551247

Dot. Arch. NIKO GARELLI S.S. 28 anni, 41 - 12084 Mondovì (CN) # 0174/551247

Dot. Arch. DANIELE BORINA S.S. 28 anni, 41 - 12084 Mondovì (CN) # 0174/551247

Dot. Arch. NIKO GARELLI S.S. 28 anni, 41 - 12084 Mondovì (CN) # 0174/551247

Dot. Arch. DANIELE BORINA S.S. 28 anni, 41 - 12084 Mondovì (CN) # 0174/551247

Dot. Arch. NIKO GARELLI S.S. 28 anni, 41 - 12084 Mondovì (CN) # 0174/551247

Dot. Arch. DANIELE BORINA S.S. 28 anni, 41 - 12084 Mondovì (CN) # 0174/551247

Dot. Arch. NIKO GARELLI S.S. 28 anni, 41 - 12084 Mondovì (CN) # 0174/551247

Dot. Arch. DANIELE BORINA S.S. 28 anni, 41 - 12084 Mondovì (CN) # 0174/551247

Dot. Arch. NIKO GARELLI S.S. 28 anni, 41 - 12084 Mondovì (CN) # 0174/551247

Dot. Arch. DANIELE BORINA S.S. 28 anni, 41 - 12084 Mondovì (CN) # 0174/551247

Dot. Arch. NIKO GARELLI S.S. 28 anni, 41 - 12084 Mondovì (CN) # 0174/551247

Dot. Arch. DANIELE BORINA S.S. 28 anni, 41 - 12084 Mondovì (CN) # 0174/551247

Dot. Arch. NIKO GARELLI S.S. 28 anni, 41 - 12084 Mondovì (CN) # 0174/551247

Dot. Arch. DANIELE BORINA S.S. 28 anni, 41 - 12084 Mondovì (CN) # 0174/551247

Dot. Arch. NIKO GARELLI S.S. 28 anni, 41 - 12084 Mondovì (CN) # 0174/551247

Dot. Arch. DANIELE BORINA S.S. 28 anni, 41 - 12084 Mondovì (CN) # 0174/551247

Dot. Arch. NIKO GARELLI S.S. 28 anni, 41 - 12084 Mondovì (CN) # 0174/551247

Dot. Arch. DANIELE BORINA S.S. 28 anni, 41 - 12084 Mondovì (CN) # 0174/551247

Dot. Arch. NIKO GARELLI S.S. 28 anni, 41 - 12084 Mondovì (CN) # 0174/551247

Dot. Arch. DANIELE BORINA S.S. 28 anni, 41 - 12084 Mondovì (CN) # 0174/551247

Dot. Arch. NIKO GARELLI S.S. 28 anni, 41 - 12084 Mondovì (CN) # 0174/551247

Dot. Arch. DANIELE BORINA S.S. 28 anni, 41 - 12084 Mondovì (CN) # 0174/551247

Dot. Arch. NIKO GARELLI S.S. 28 anni, 41 - 12084 Mondovì (CN) # 0174/551247

Dot. Arch. DANIELE BORINA S.S. 28 anni, 41 - 12084 Mondovì (CN) # 0174/551247

Dot. Arch. NIKO GARELLI S.S. 28 anni, 41 - 12084 Mondovì (CN) # 0174/551247

Dot. Arch. DANIELE BORINA S.S. 28 anni, 41 - 12084 Mondovì (CN) # 0174/551247

Dot. Arch. NIKO GARELLI S.S. 28 anni, 41 - 12084 Mondovì (CN) # 0174/551247

Dot. Arch. DANIELE BORINA S.S. 28 anni, 41 - 12084 Mondovì (CN) # 0174/551247

Dot. Arch. NIKO GARELLI S.S. 28 anni, 41 - 12084 Mondovì (CN) # 0174/551247

Dot. Arch. DANIELE BORINA S.S. 28 anni, 41 - 12084 Mondovì (CN) # 0174/551247

DETTAGLI PANNELLI FOTOVOLTAICI
Scala 1:50

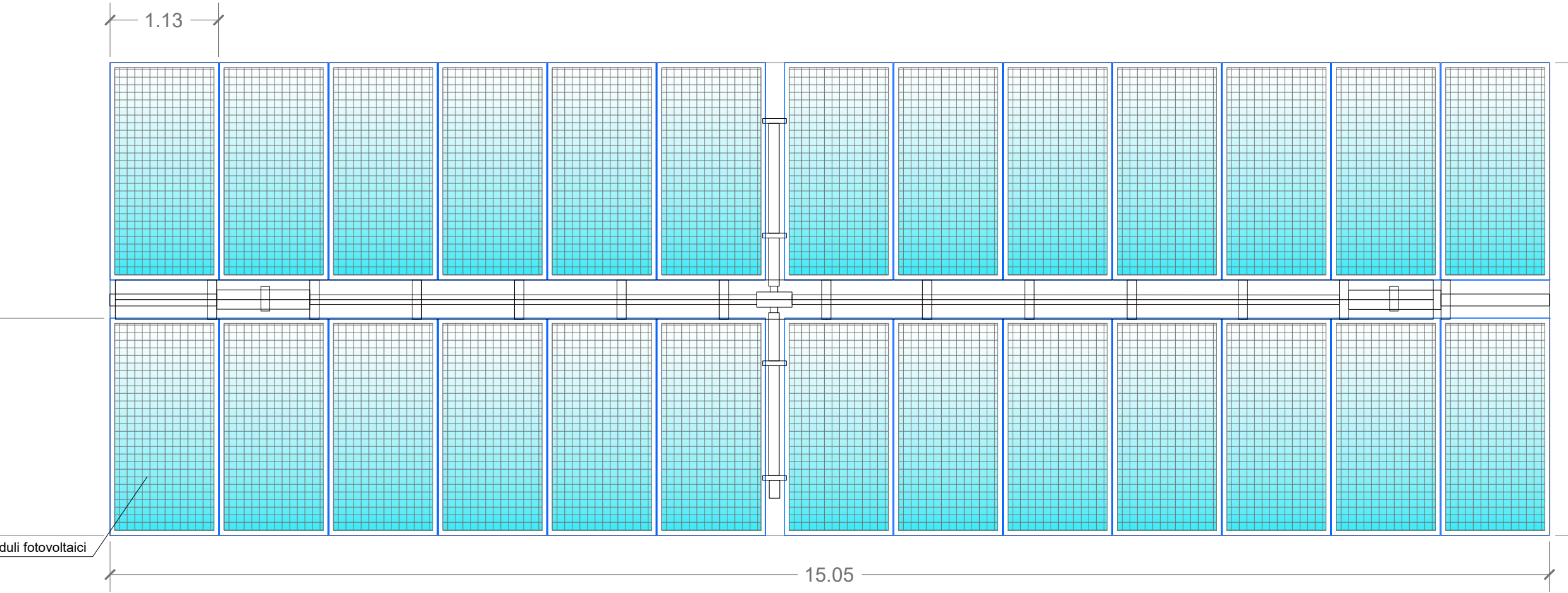
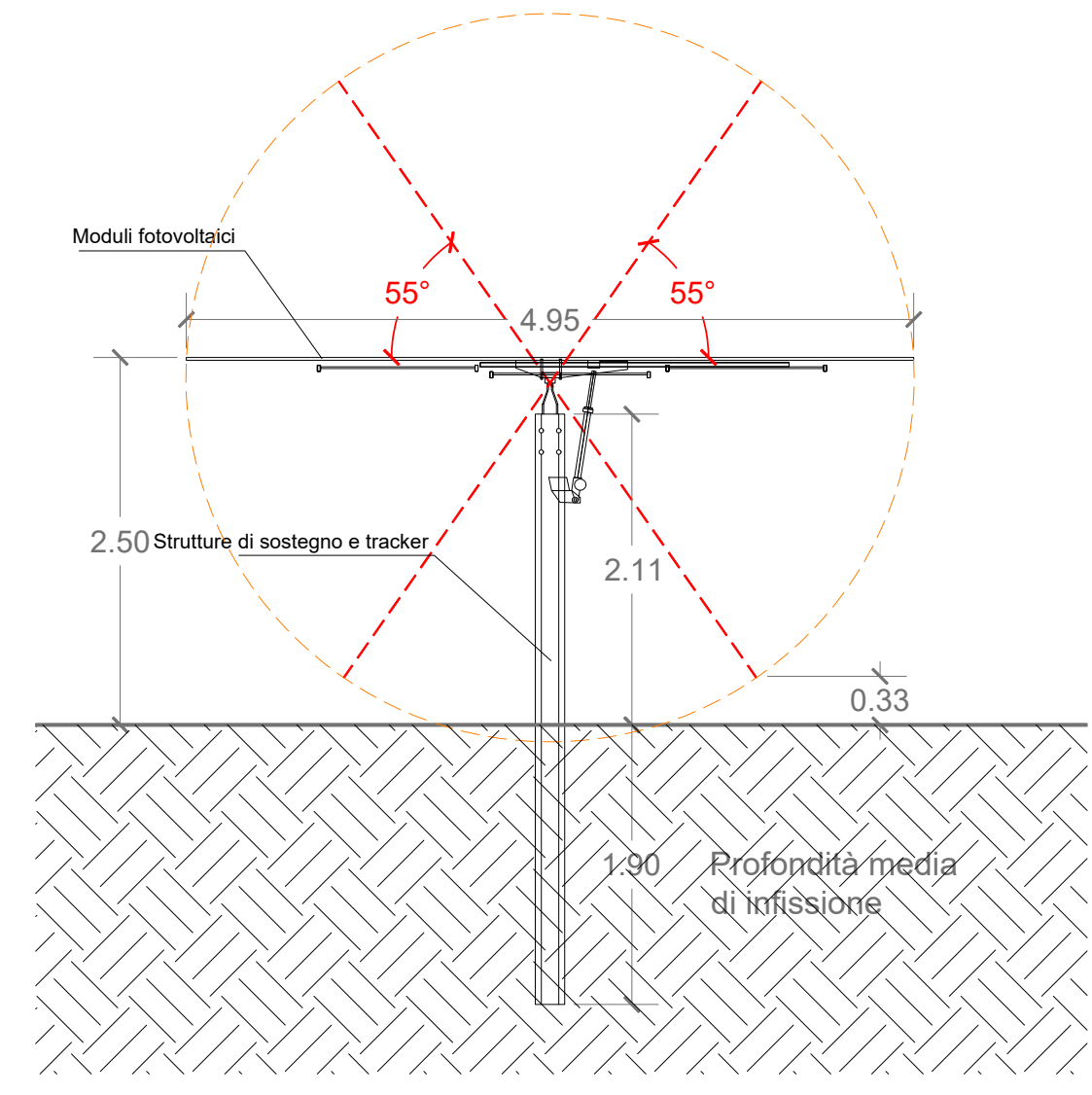
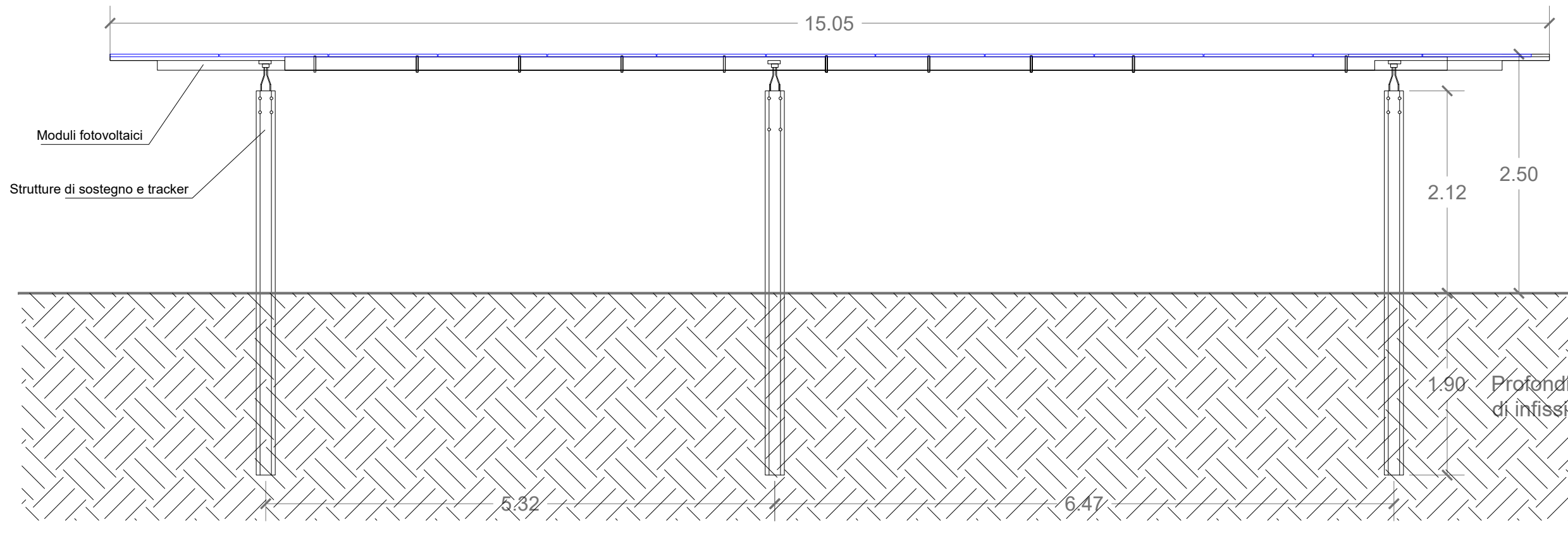

**PIANTE PROSPETTI SEZIONI
MODULI FV**

Identificatore nome file:
T14-MODULI FV

PROGETTO DEFINITIVO
Ottobre 2021

LAVORO
COS 001/01

SCALA
1:50

Elaborato
T14

RICHIEDENTE

EDISON

EDISON Spa
Sede Legale:
Foro Buonaparte, 31 - 20121 Milano
Partita IVA 0626333014
☎ 02/9222.1
www.edison.it

Si riservano tutti i diritti di divulgazione e riproduzione del presente documento senza specifica autorizzazione ai sensi della legge 24.04.41 n.633 e s.m.e. int.

Engineering Drawings Electrical Performance & Temperature Dependence

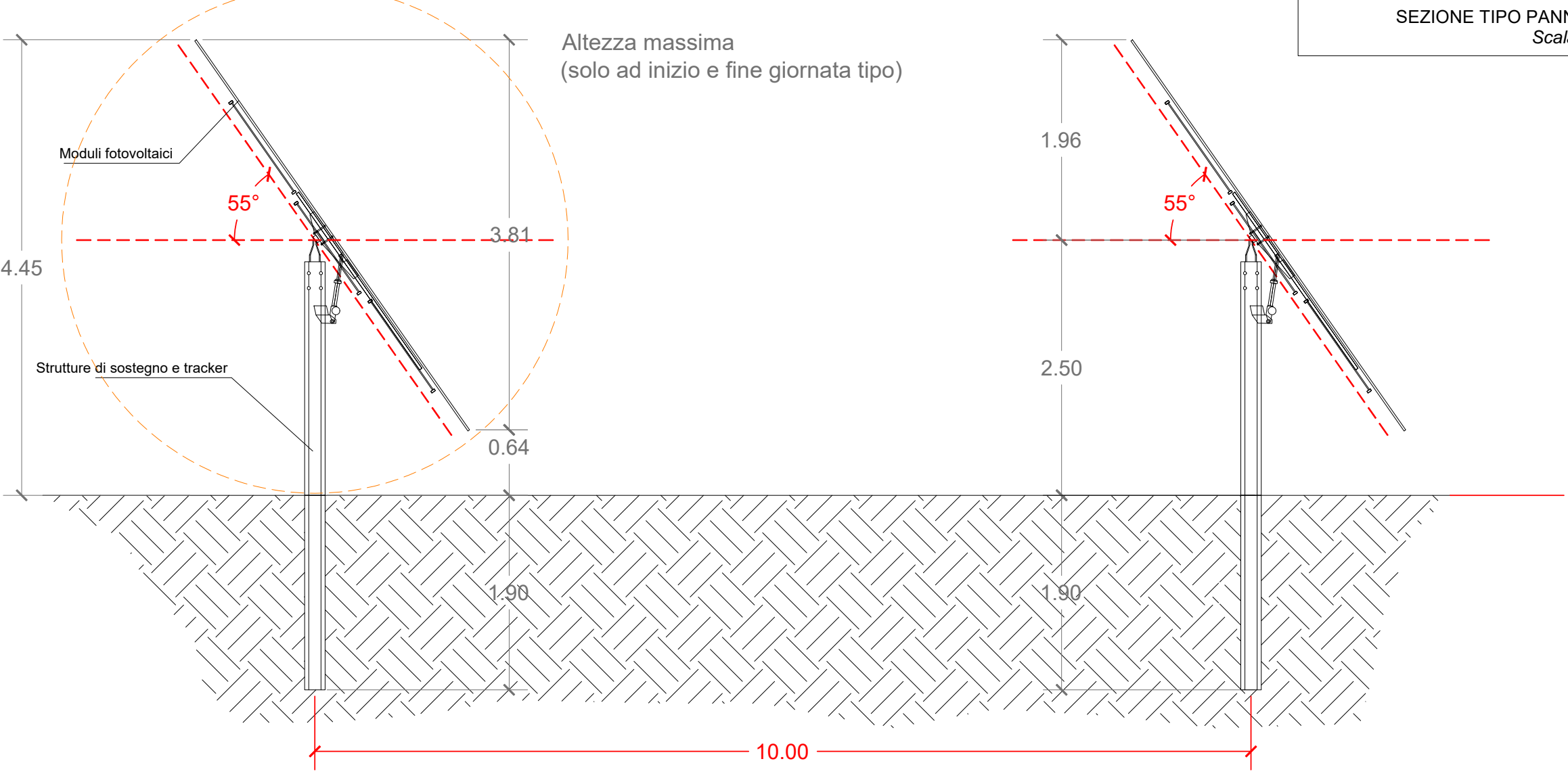

SPECIFICATIONS

Module Type	JKM530M-72HL4		JKM535M-72HL4		JKM540M-72HL4		JKM545M-72HL4		JKM550M-72HL4	
	STC	NOCT	STC	NOCT	STC	NOCT	STC	NOCT	STC	NOCT
Maximum Power (Pmax)	530Wp	394Wp	535Wp	398Wp	540Wp	402Wp	545Wp	405Wp	550Wp	409Wp
Maximum Power Voltage (Vmp)	40.56V	37.84V	40.63V	37.91V	40.70V	38.08V	40.80V	38.25V	40.90V	38.42V
Maximum Power Current (Imp)	13.07A	10.42A	13.17A	10.50A	13.27A	10.55A	13.36A	10.60A	13.45A	10.65A
Open-circuit Voltage (Voc)	49.26V	46.50V	49.34V	46.57V	49.42V	46.65V	49.52V	46.74V	49.62V	46.84V
Short-circuit Current (Isc)	13.71A	11.07A	13.79A	11.14A	13.85A	11.19A	13.94A	11.26A	14.03A	11.33A
Module Efficiency STC (%)	20.55%		20.75%		20.94%		21.13%		21.33%	
Operating Temperature(°C)	-40°C~+85°C									
Maximum system voltage	1000/1500VDC (IEC)									
Maximum series fuse rating	25A									
Power tolerance	0~+3%									
Temperature coefficients of Pmax	-0.35%/°C									
Temperature coefficients of Voc	-0.28%/°C									
Temperature coefficients of Isc	0.048%/°C									
Nominal operating cell temperature (NOCT)	45±2°C									

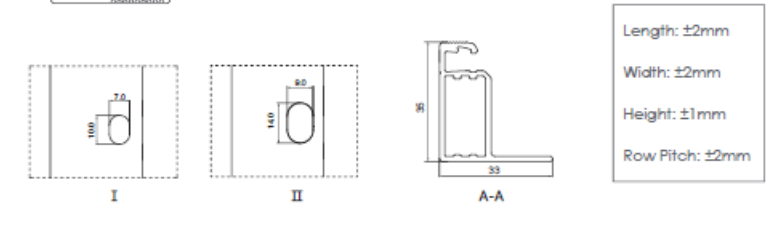
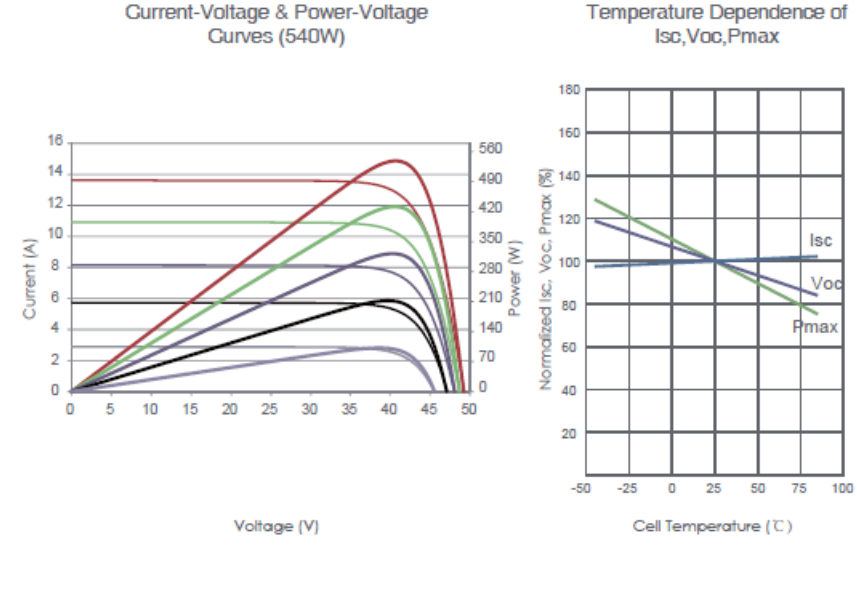
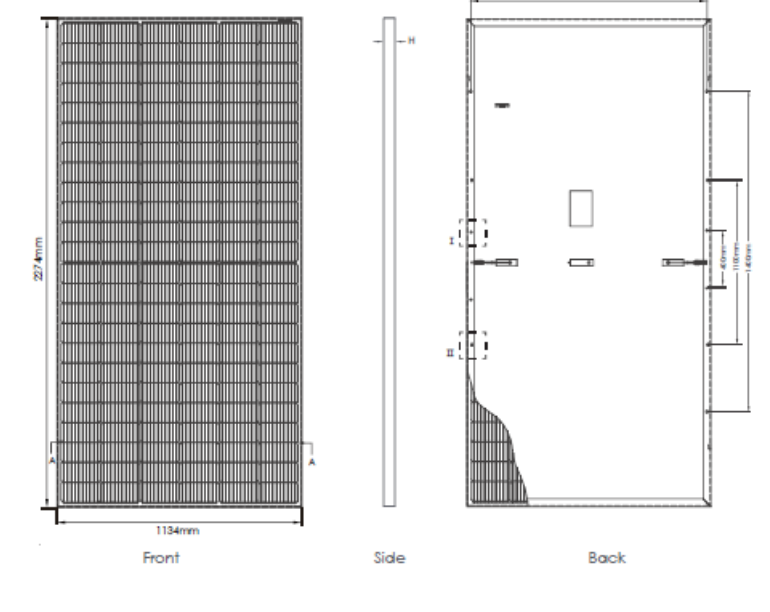

Packaging Configuration
(Two pallets = One stack)
31 pcs/pallets, 62 pcs/stack, 620 pcs/ 40HQ Container

Mechanical Characteristics

Cell type	P type Mono-crystalline
No. of cells	144 (6x24)
Dimensions	2274x1134x35mm (89.53x44.65x1.38 inch)
Weight	28.9 kg (63.7 lbs)
Front Glass	3.2mm Anti-Reflection Coating, High Transmission, Low Iron, Tempered Glass
Frame	Anodized Aluminium Alloy
Junction Box	IP68 Rated
Output Cables	TUV 1x4.0mm² (+): 400mm, (-): 200mm or Customized Length

