

STRALCIO PLANIMETRICO NASTRO 4 - Scala 1:1000 / EXTRAIT PLANIMÉTRIQUE CONVOYEUR 4 - Echelle 1:1000

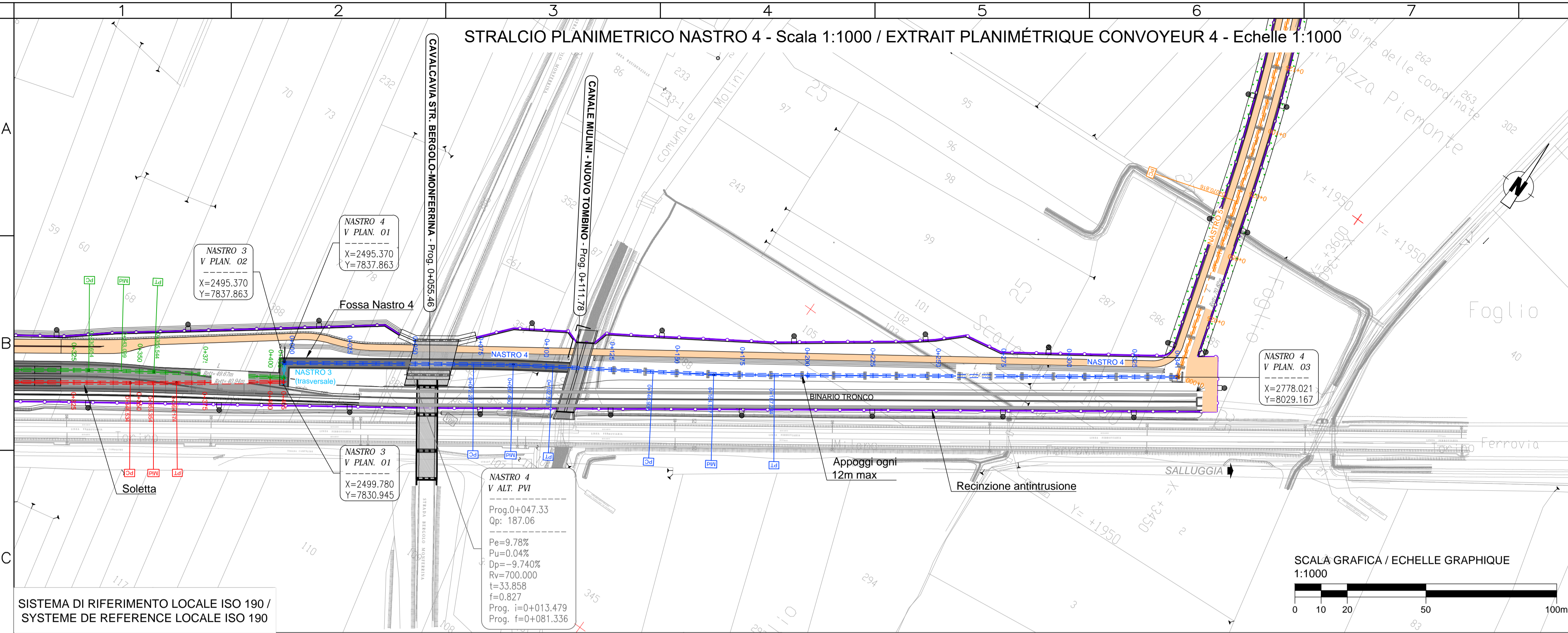

QUADRO D'UNIONE / CADRE DE L'UNION

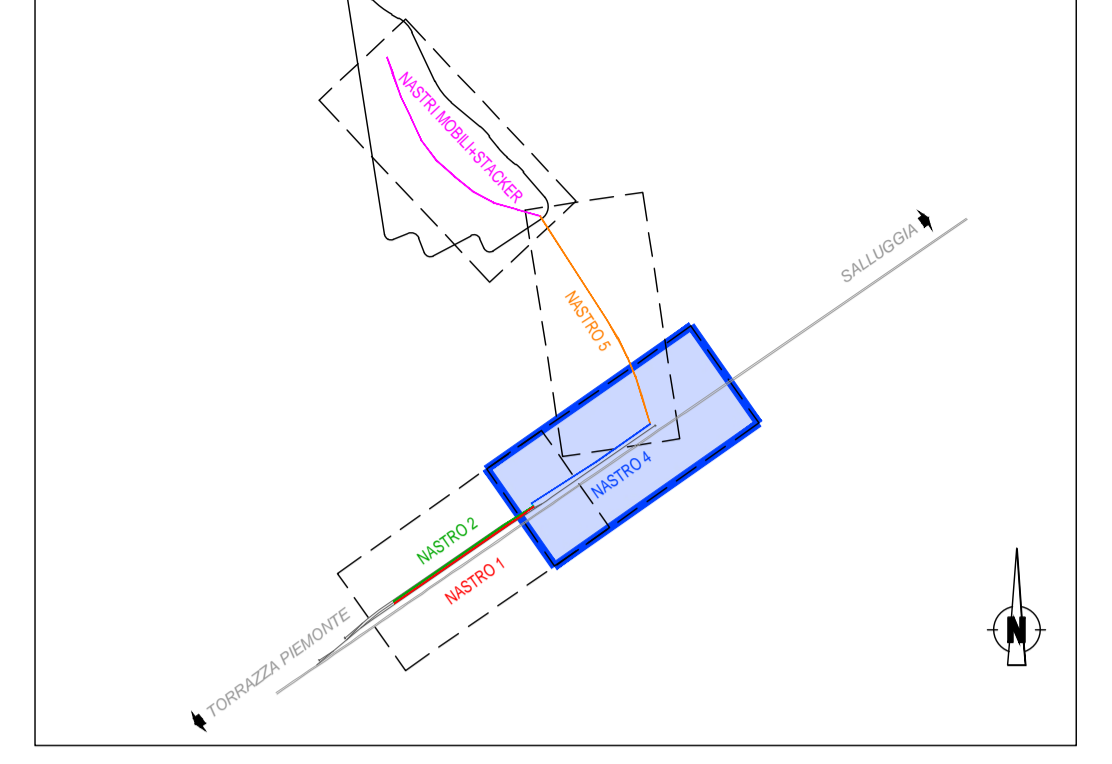

LEGENDA / LEGENDE

- ⊕ Vertice Planimetrico / Sommets Planimétriques
- ⊕ Vertice Altimetrico / Sommets Altimétriques
- ⊕ Ettometrici / Hectométrés
- ⊕ Chilometrici / Kilométrés
- L Lunghezza (m) / Longueur (m)
- R Raggio (m) / Rayon (m)
- Sv Sviluppo Curva Circolare / Longueur Courbe Circulaire

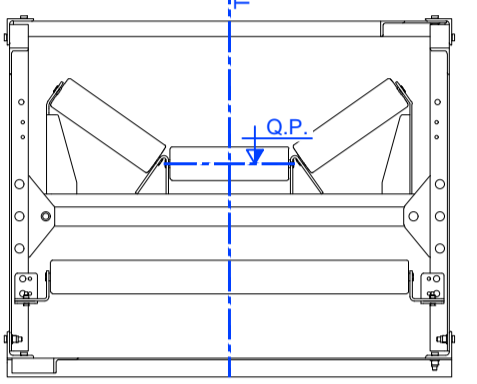

NOTE / NOTES

DOCUMENTI DI RIFERIMENTO / DOCUMENT DE REFERENCE

Da 4_1000_C18190_ST11_O_0_E_PLGC_0904 a 4_1000_C18190_ST11_O_0_E_PLGC_0908 Planimetrie e profili nastri
 Da 4_1000_C18190_ST11_O_0_E_PLGC_0909 a 4_1000_C18190_ST11_O_0_E_PLGC_0910 - Profili e sezioni tipo Nastri
 Da 4_1000_C18190_ST11_O_0_E_PLGC_0911 a 4_1000_C18190_ST11_O_0_E_PLGC_0913 Sezioni e particolari
 4_1000_C18190_ST11_O_0_E_PLGC_0916 - Pianta fondazioni muri



NOUVELLE LIGNE LYON TURIN - NUOVA LINEA TORINO LIONE
 PARTIE COMMUNE FRANCO-ITALIENNE - PARTE COMUNE ITALO-FRANCOISE
 CUP C11J0500030001 - LOTTO COSTRUTTIVO 1

Chantier Opérationnel 010 / Cantiere Operativo 010
 CIG ZDB1F80CCO

PARTIE CONCEPTION MOE RACCORD FERROVIAIRE DE LA ZONE TECHNIQUE DE TORRAZZA - PROGETTO ESECUTIVO DELL'AREA TECNICA DI TORRAZZA

PROJET DU CONVOYEUR - PROGETTO NASTRO TRASPORTATORE
 PLANIMETRIE ET PROFIL EN LONG DU CONVOYEUR 4 - PLANIMETRIA E PROFILO NASTRO 4

Indice	Data / Data	Modifiche / Modifiche	Elab. per / Concepto da	Verif. per / Controllato da	Autoriz. per / Autorizzato da
0	11/07/2019	Prima emissione a seguito validazione Telt Première diffusion après validation Telt	E. Proserpio (GD)	A. Fernandez (GD)	A. Marra (AD)
A	11/09/2019	Revisione a seguito commenti Telt Révision après commentaires Telt	E. Proserpio (GD)	A. Fernandez (GD)	A. Marra (AD)

4 1 0 0 C 1 8 1 9 0 S T 1 1 0 0 **E P L G C 0 9 0 6 A**

IL PROGETTISTA MANDATARIO/LE DESIGNER
AI ENGINEERING S.r.l.
 Via Zappalino, 80 | 10121 Torino
 Tel. +39 011 58 18 11 | Fax +39 011 58 85 882
 E-mail: info@aiengp.it | Web: www.aiengp.it

IL PROGETTISTA MANDANTE/LE DESIGNER
GEODATA ENGINEERING S.p.A.
 Corso Salaria, 82 | 00137 Roma
 Tel. +39 06 52 00 11 | Fax +39 06 52 00 12
 E-mail: geodata@geodata.it | Web: www.geodata.it

1:1000/1:100
 SCALA / ECHELLE

IL DIRETTORE DEI LAVORI/LE MAÎTRE D'OUVRAGE

TELT sas - Savoie Technolac - Bâtiment "Homère"
 13 allée du Lac de Constance - 73370 LE BOURGET DU LAC (France)
 Tél. : +33 (0)4 79 68 56 50 - Fax : +33 (0)4 79 68 56 75
 RCS Chambéry 439 556 952 - TVA FR 03439556952
 Propriété TELT. Tous droits réservés.
 Propriété TELT. Tutti i diritti riservati.

SISTEMA DI RIFERIMENTO LOCALE ISO 190 /
 SYSTEME DE REFERENCE LOCALE ISO 190

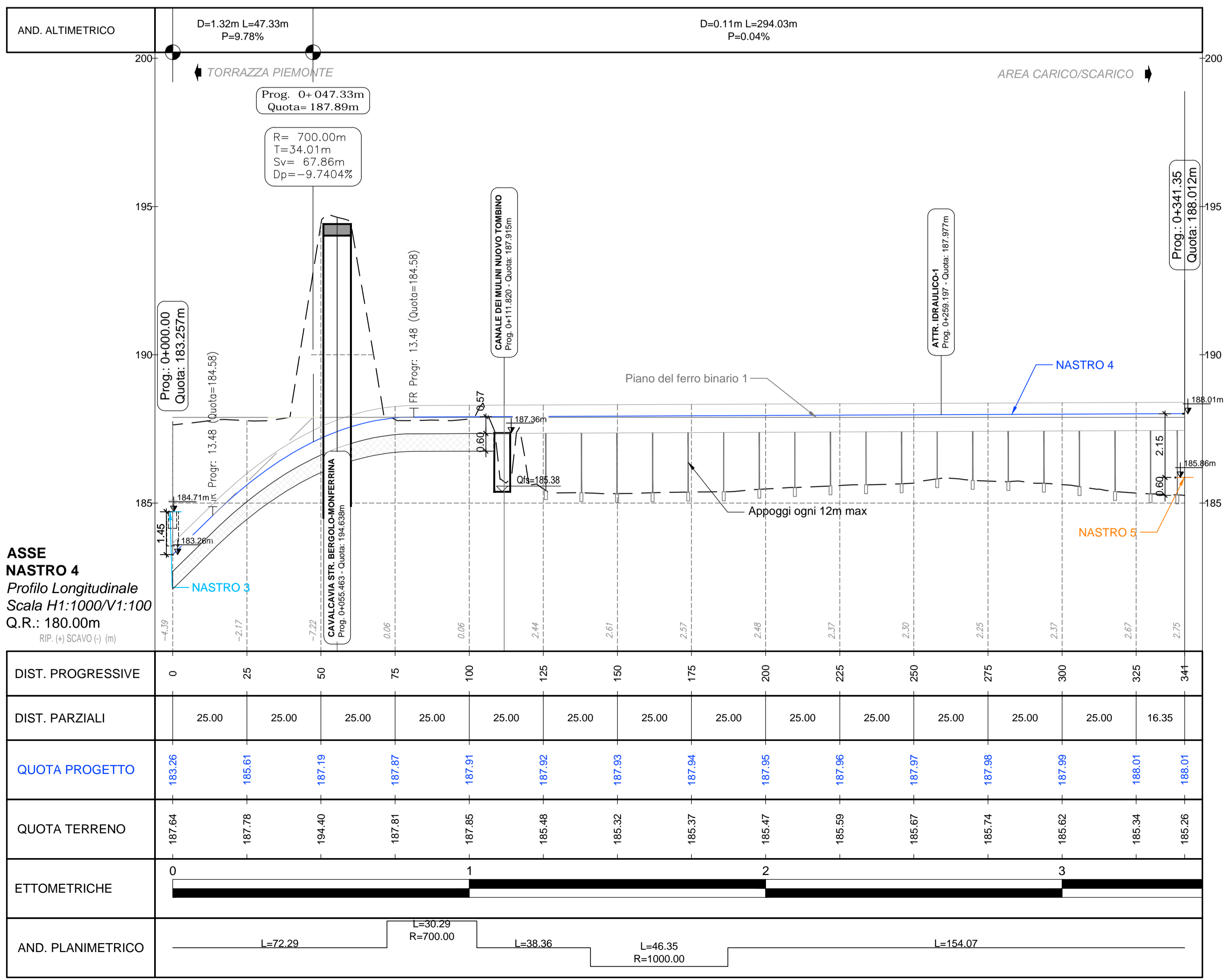

ASSE NASTRO 4
 Profilo Longitudinale
 Scala H1:1000/V1:100
 Q.R.: 180.00m
 R.I.P. (+) SCAVO (-) (m)

DIST. PROGRESSIVE	0	25	50	75	100	125	150	175	200	225	250	275	300	325	341
DIST. PARZIALI		25.00	25.00	25.00	25.00	25.00	25.00	25.00	25.00	25.00	25.00	25.00	25.00	25.00	16.35
QUOTA PROGETTO	183.26	185.61	187.19	187.87	187.91	187.92	187.93	187.94	187.95	187.96	187.97	187.98	187.99	188.01	188.01
QUOTA TERRENO	187.64	187.78	194.40	187.81	187.85	185.48	185.32	185.37	185.47	185.59	185.67	185.74	185.62	185.34	185.28
ETTOMETRICHE	0				1				2				3		
AND. PLANIMETRICO			L=72.29			L=30.29 R=700.00			L=38.36				L=46.35 R=1000.00		L=154.07

Scale PLOTTINGO B/N
 mm. plotter per 1 MAX. DX

RED 0.16 0.24 0.32 0.40 0.50 0.60 0.80 1.00 1.50 2.00 3.00 4.00 6.00 8.00 10.00 15.00 20.00 30.00 40.00 60.00 80.00 100.00

GREEN 0.16 0.24 0.32 0.40 0.50 0.60 0.80 1.00 1.50 2.00 3.00 4.00 6.00 8.00 10.00 15.00 20.00 30.00 40.00 60.00 80.00 100.00

BLUE 0.16 0.24 0.32 0.40 0.50 0.60 0.80 1.00 1.50 2.00 3.00 4.00 6.00 8.00 10.00 15.00 20.00 30.00 40.00 60.00 80.00 100.00

WHITE 0.16 0.24 0.32 0.40 0.50 0.60 0.80 1.00 1.50 2.00 3.00 4.00 6.00 8.00 10.00 15.00 20.00 30.00 40.00 60.00 80.00 100.00