

COMMITTENTE:



PROGETTAZIONE:



DIREZIONE TECNICA

U.O. COORDINAMENTO DI SISTEMA E PFTE

PROGETTO FATTIBILITA' TECNICO ECONOMICA

**POTENZIAMENTO INFRASTRUTTURALE ORTE-FALCONARA
RADDOPPIO DELLA TRATTA PM228-CASTELPLANIO
LOTTO 02**

INFRASTRUTTURA

BOOK SEZIONI TRASVERSALI CORRENTI - PASSO 100M

SCALA :

1 : 200

COMMESSA LOTTO FASE ENTE TIPO DOC. OPERA/DISCIPLINA PROGR. REV.

IR0F 02 R 10 W9 IF0001 001 A

Revis.	Descrizione	Redatto	Data	Verificato	Data	Approvato	Data	Autorizzato	Data
A	EMMISSIONE ESECUTIVA	P. Cucino	Sett. 2021	P. Gobini	Sett. 2021	C. Urzuoli	Sett. 2021	G. Ingresso	Settembre 2021

ITALFERR S.p.A.
COORDINAMENTO DI SISTEMA
Dot. Ing. GIULIANA INGROSSO
Ordine degli Ingegneri di ROMA N. 2002

File:IR0F02R10W9IF0001001A.dwg

n. Elab.:

SEZIONE N°: 2
 QT. PROG.: 203.495
 Progr. km: 100.000
 Dist. prec.: 100.000
 Dist. succ.: 100.000

LINEA STORICA ALBACINA CASTELPLANIO
Prog. 203.495 - Qt. 203.495

1:200

Qt. rif. 192.000

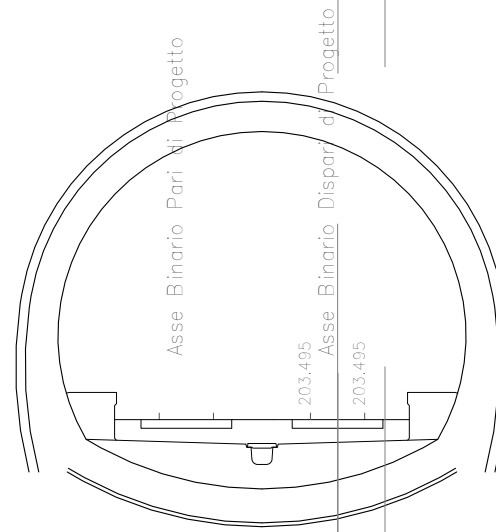

Quote Progetto						
Quote Terreno		-212.96	-214.73	225.03 225.04 -225.37	-231.58	-245.18
Distanze Parz. Progetto						
Distanze Progetto						
Distanze Terreno		-21.02	-17.70	0.00 0.01 -1.25	-7.30	-21.83

SEZIONE N°: 3
 QT. PROG.: 202.559
 Progr. km: 200.000
 Dist. prec.: 100.000
 Dist. succ.: 100.000

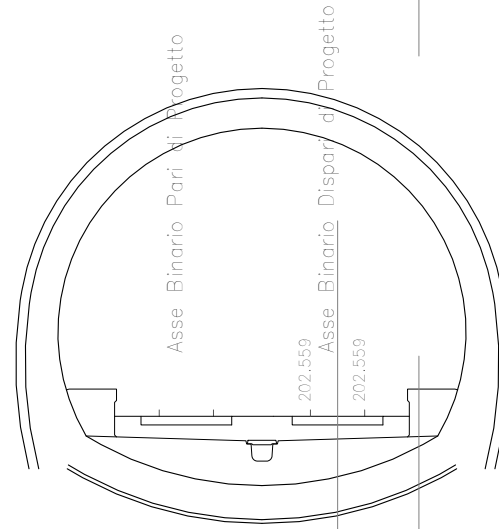

1:200

Qt. rif. 185.000

Quote Progetto	
Quote Terreno	- 244.19 - 249.32 - 250.00 - 250.93
Distanze Parz. Progetto	
Distanze Progetto	
Distanze Terreno	- 16.16 - 0.00 - 2.15 - 6.33

SEZIONE N°: 4
 QT. PROG.: 201.669
 Progr. km: 300.000
 Dist. prec.: 100.000
 Dist. succ.: 100.000

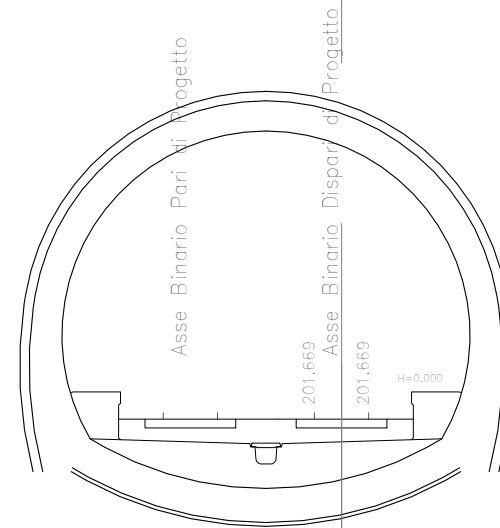

1:200

Qt. rif. 184.000

Quote Progetto	
Quote Terreno	<div style="display: flex; justify-content: space-between;"> 243.92 250.00 </div>
Distanze Parz. Progetto	
Distanze Progetto	
Distanze Terreno	<div style="display: flex; justify-content: space-between;"> 0.00 17.99 </div>

SEZIONE N°: 5
 QT. PROG.: 201.471
 Progr. km: 400.000
 Dist. prec.: 100.000
 Dist. succ.: 100.000

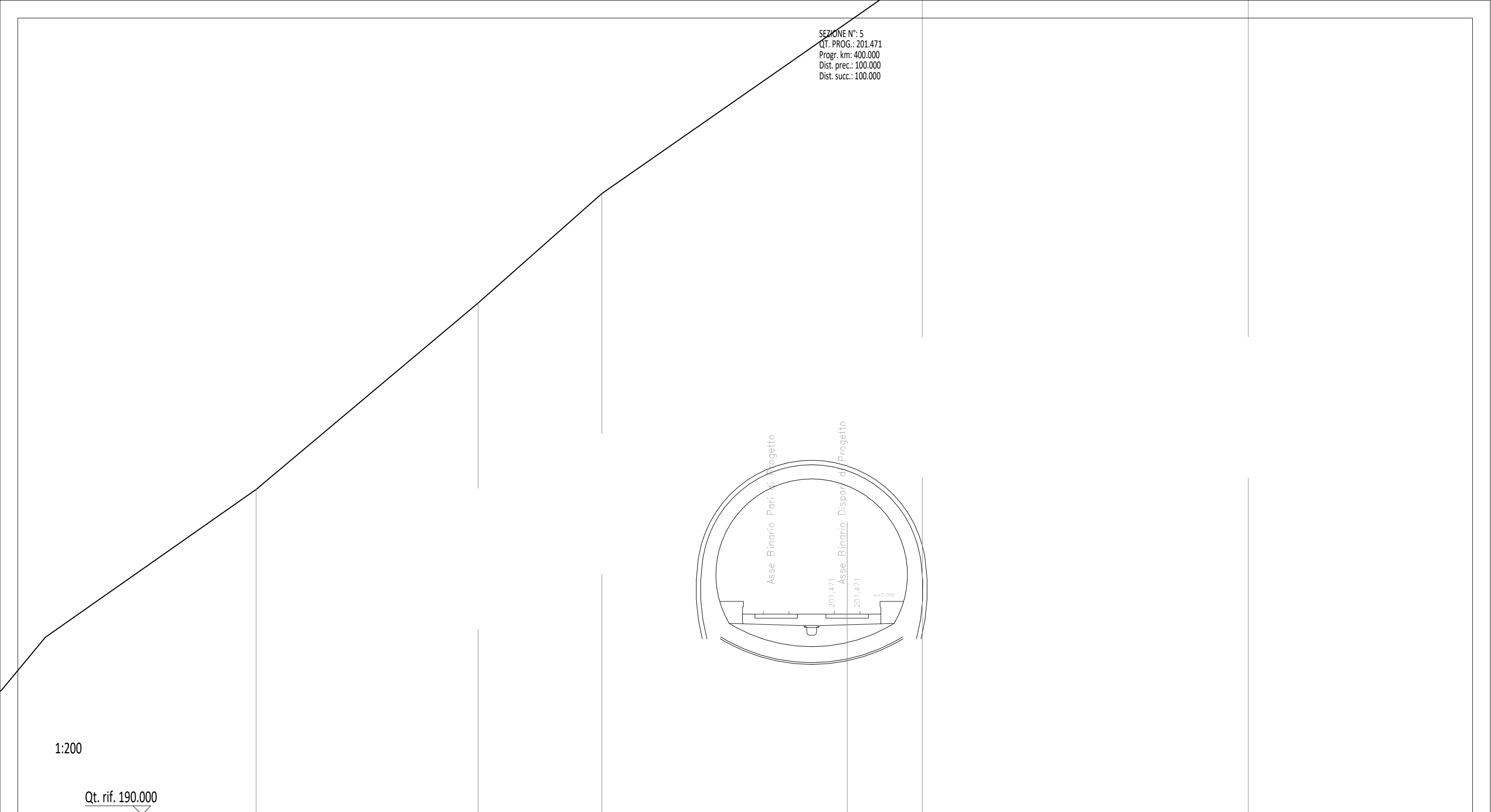

1:200

Qt. rif. 190.000

Quote Progetto						
Quote Terreno	-208.33	-218.84	-225.00	-234.64	-237.59	-250.00
Distanze Parz. Progetto						
Distanze Progetto						
Distanze Terreno	33.31	-20.80	-13.83	0.00	-4.24	-22.61

SEZIONE N°: 6
 QT. PROG.: 201.371
 Progr. km: 500.000
 Dist. prec.: 100.000
 Dist. succ.: 100.000

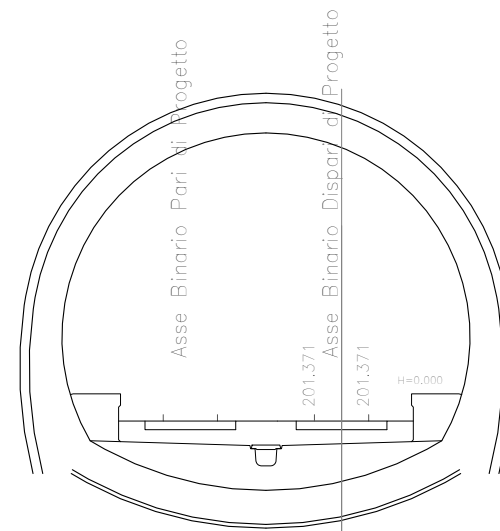

1:200

Qt. rif. 191.000

Quote Progetto	
Quote Terreno	-231,87
Distanze Parz. Progetto	
Distanze Progetto	
Distanze Terreno	-27,30

-250,04

-0,00

SEZIONE N°: 7
 QT. PROG.: 201.271
 Progr. km: 600.000
 Dist. prec.: 100.000
 Dist. succ.: 100.000

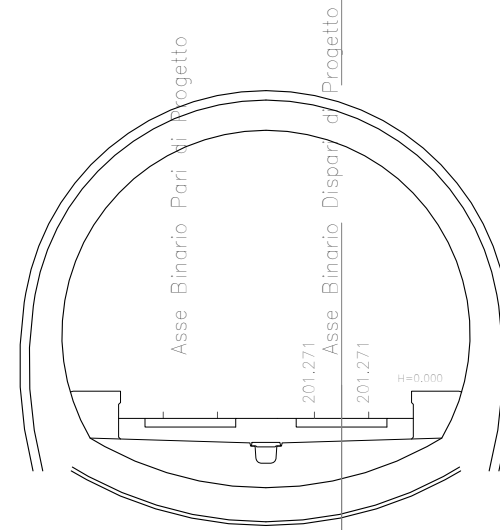

1:200

Qt. rif. 183.000

Quote Progetto			
Quote Terreno	-275.00	-279.32	-281.25
Distanze Parz. Progetto			
Distanze Progetto			
Distanze Terreno	-33.36	-0.00	-14.99

SEZIONE N°: 8
 QT. PROG.: 201.171
 Progr. km: 700.000
 Dist. prec.: 100.000
 Dist. succ.: 100.000

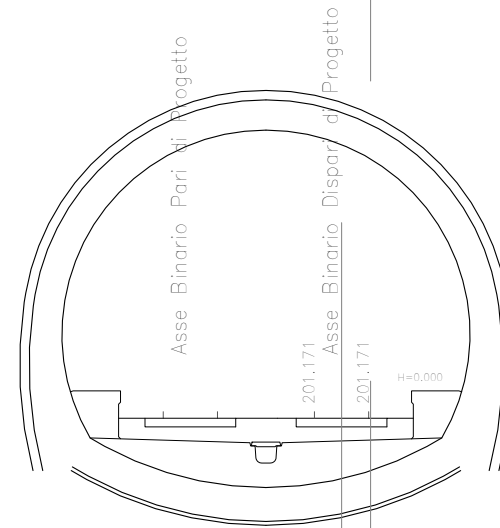

1:200

Qt. rif. 183.000

Quote Progetto	
Quote Terreno	- 288.79 - 286.98 - 289.76 - 280.30
Distanze Parz. Progetto	
Distanze Progetto	
Distanze Terreno	- 0.00 - 0.77 - 5.39 - 30.73

SEZIONE N°: 9
 QT. PROG.: 201.071
 Progr. km: 800.000
 Dist. prec.: 100.000
 Dist. succ.: 100.000

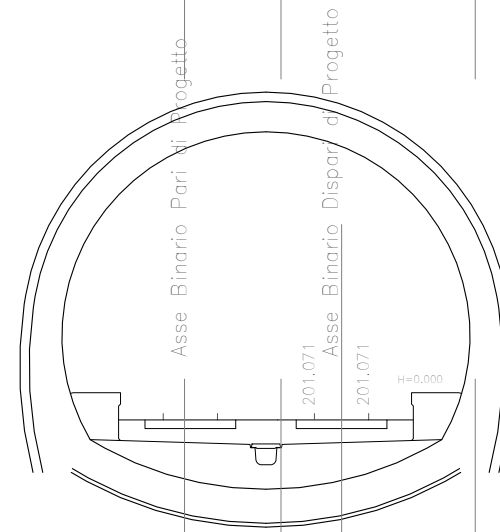

1:200

Qt. rif. 183.000

Quote Progetto													
Quote Terreno		-275.00	-272.55	-272.53	-269.84	-269.83	-269.69	-269.39	-268.78		-266.13		-264.99
Distanze Parz. Progetto													
Distanze Progetto													
Distanze Terreno		-20.88	-13.54	-12.31	-4.16	-1.61	0.00	3.54	7.17		19.19		25.40

SEZIONE N°: 10
 QT. PROG.: 200.971
 Progr. km: 900.000
 Dist. prec.: 100.000
 Dist. succ.: 75.000

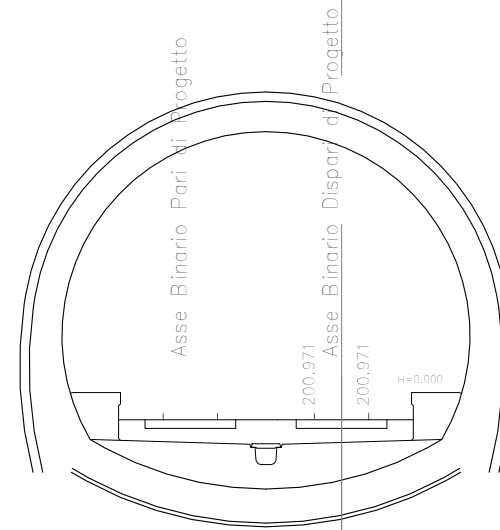

1:200

Qt. rif. 183.000

Quote Progetto								
Quote Terreno	-225.61	-225.58	-227.33	-227.09	-230.93	-232.91	-232.47	-236.77
Distanze Parz. Progetto								
Distanze Progetto								
Distanze Terreno	-31.29	-30.14	-17.99	-17.14	0.00	8.88	11.83	28.52

SCAVI E BONIFICHE	
SCAVO DI SBANCAMENTO	60.626 m ²
PAVIMENTAZIONI	
SUPERCOMPATTATO	3.810 m ²
SUBBALLAST	1.524 m ²

SEZIONE N°: 11
 QT. PROG.: 200.896
 Progr. km: 975.000
 Dist. prec.: 75.000
 Dist. succ.: 125.000

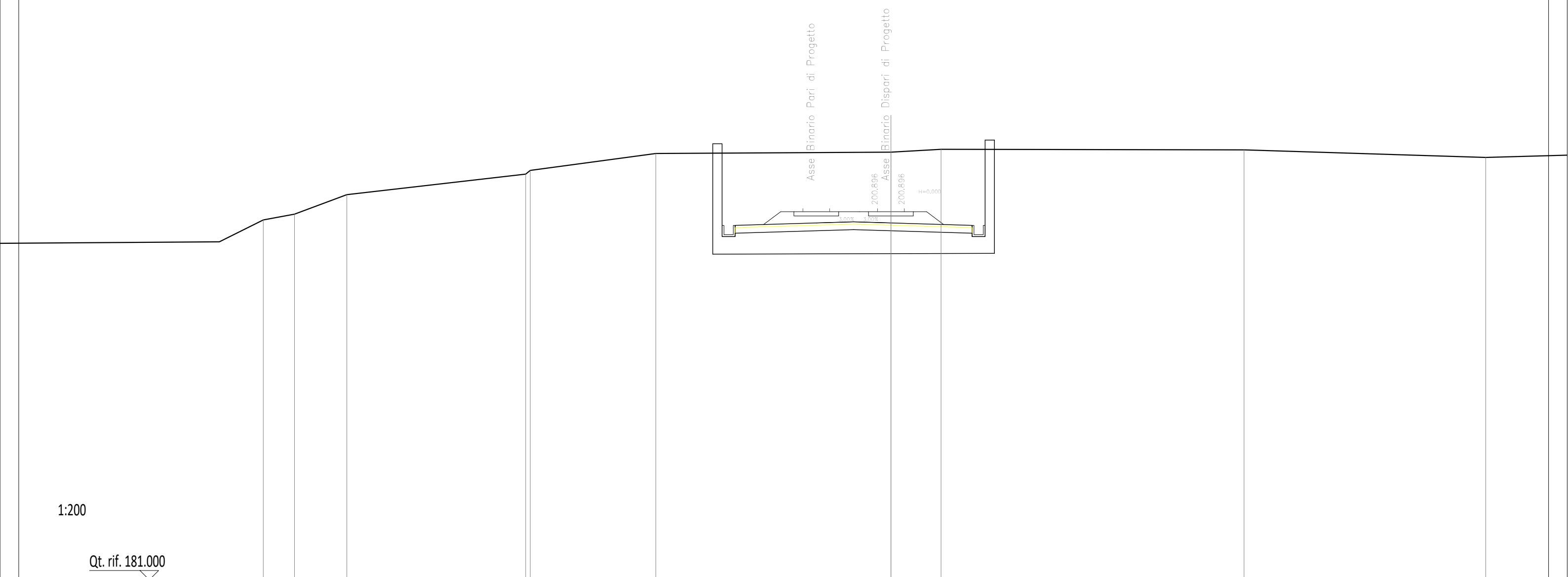

Quote Progetto																				
Quote Terreno	-200,28	-200,60	-201,64	-202,74 -202,94	-203,85	-199,39 -199,39	-199,70	-199,76	-199,70	-203,92	-204,07	-199,39 -199,39		-204,04						-203,64
Distanze Parz. Progetto						0,70	6,35		6,35		0,70									
Distanze Progetto						-9,05 -8,35	-4,00	-2,00	-0,00		-4,35 -5,05									
Distanze Terreno	-33,64	-31,97	-29,16	-19,57 -19,33	-12,60				-0,00	-2,68				-18,93						-31,88

SEZIONE N°: 12
 QT. PROG.: 200.755
 Progr. km: 1100.000
 Dist. prec.: 125.000
 Dist. succ.: 100.000

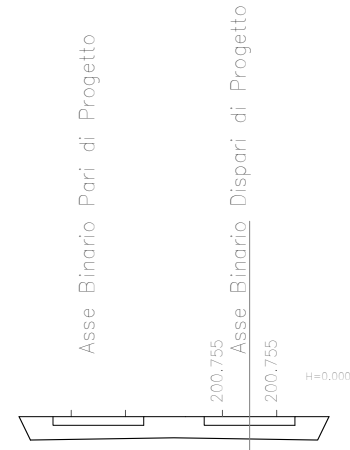

1:200

Qt. rif. 174.000

Quote Progetto	
Quote Terreno	188.42 189.78 190.92 191.58
Distanze Parz. Progetto	
Distanze Progetto	
Distanze Terreno	-13.06 -0.00 11.14 15.58

SEZIONE N°: 13
 QT. PROG.: 199.893
 Progr. km: 1200.000
 Dist. prec.: 100.000
 Dist. succ.: 100.000

LINEA STORICA ALBACINA CASTELPLANO



1:200

Qt. rif. 174.000

Quote Progetto						
Quote Terreno		-194.04	-190.67	-190.84 -190.72	-190.48	-190.73
Distanze Parz. Progetto						
Distanze Progetto						
Distanze Terreno		-12.84	-4.66	-0.00 -0.74	-6.48	-31.89

SCAVI E BONIFICHE	
SOSTITUZIONE TERRENI	14.771 m ²
SCAVO DI SBANCAMENTO	4.107 m ²
RILEVATI	
RILEVATO FERROVIARIO	85.049 m ²
TERRENO VEGETALE	19.052 m ²
PAVIMENTAZIONI	
SUPERCOMPATTATO	4.064 m ²
SUBBALLAST	1.547 m ²

SEZIONE N°: 14
 QT. PROG.: 198.786
 Progr. km: 1300.000
 Dist. prec.: 100.000
 Dist. succ.: 100.000

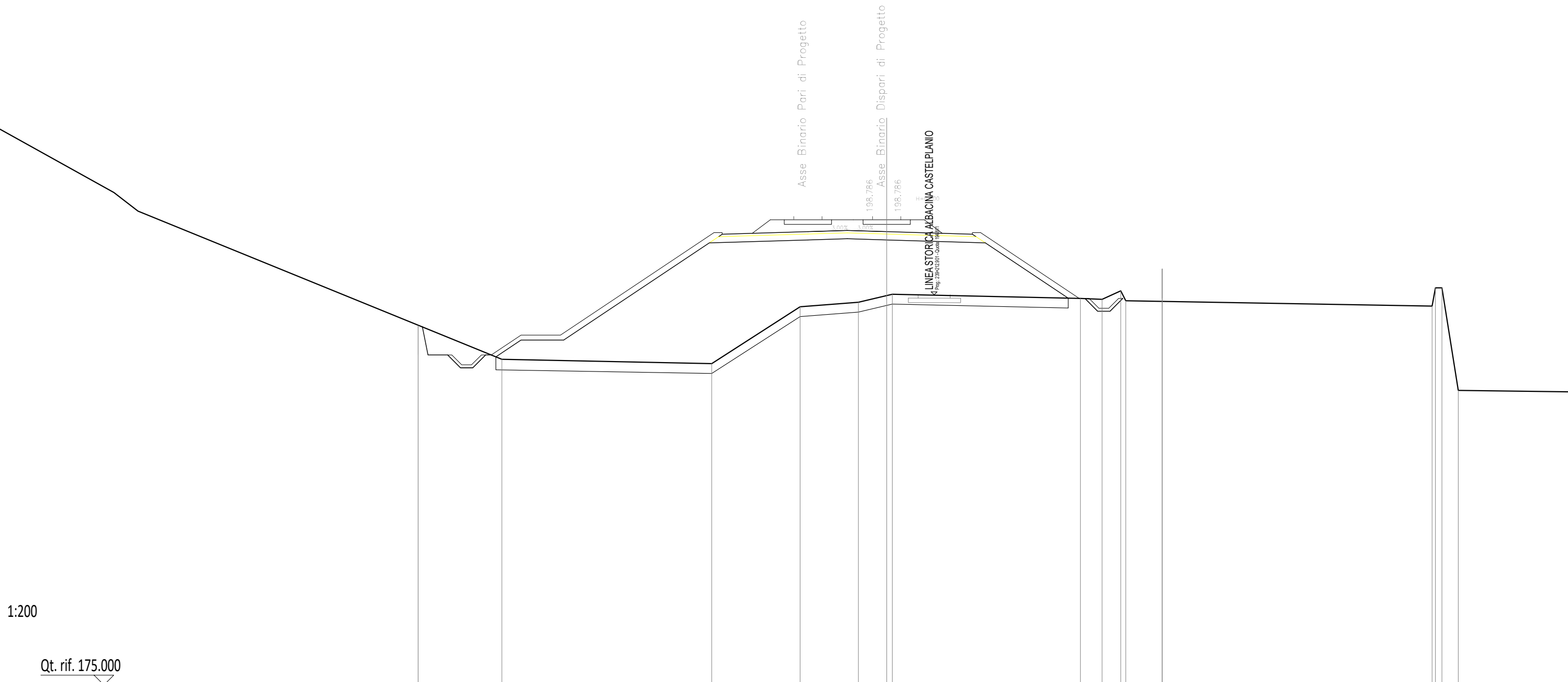

1:200

Qt. rif. 175.000

Quote Progetto	193.20 191.75 191.75 191.10 191.10 191.75 191.66 192.51 192.51 192.51 192.51 197.44 197.46 197.59 197.65 197.59 197.46 197.44 194.64 194.62 193.97 193.97 194.62
Quote Terreno	191.53 191.31 194.20 194.43 194.77 194.64 194.62 194.58 195.01 194.50 194.23 195.16 189.96
Distanze Parz. Progetto	1.00 1.92 1.51 2.00 7.80 6.35 6.35 5.01 1.92
Distanze Progetto	-23.58 -23.29 -22.29 -21.64 -21.02 -20.37 -19.85 -18.57 -18.55 -16.57 -16.40 -9.01 -8.35 -4.00 -2.00 -0.00 -4.35 -5.01 -9.22 -9.78 -10.71 -11.34 -11.89 -12.14
Distanze Terreno	-19.54 -8.89 -4.40 -1.44 -0.00 -0.28 -9.84 -10.94 -11.89 -12.14 -27.70 -26.20 -29.02

PAVIMENTAZIONI	
SUPERCOMPATTATO	2.100 m ²
SUBBALLAST	0.840 m ²

SEZIONE N°: 15
 QT. PROG.: 198.389
 Progr. km: 1400.000
 Dist. prec.: 100.000
 Dist. succ.: 100.000

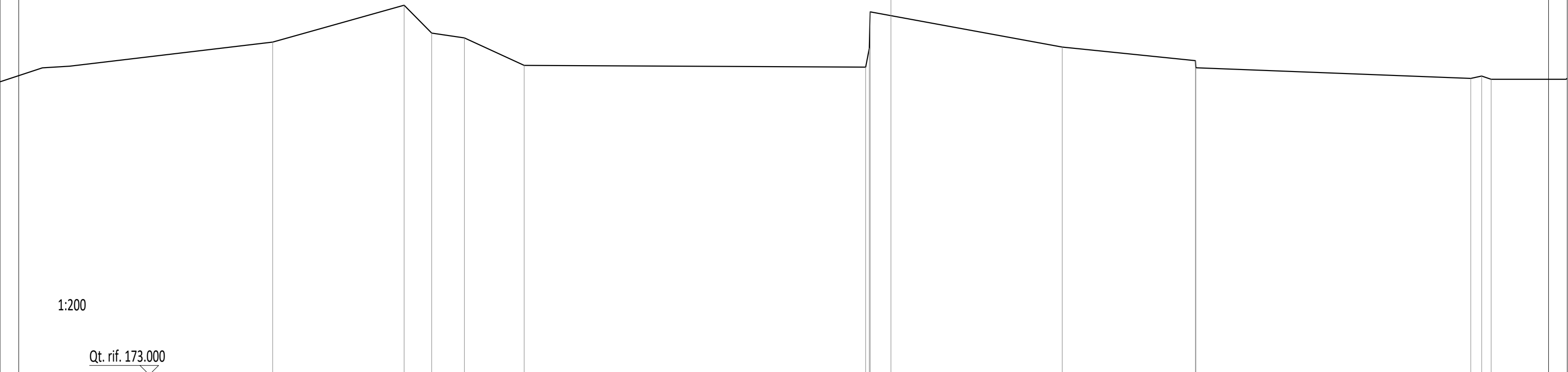
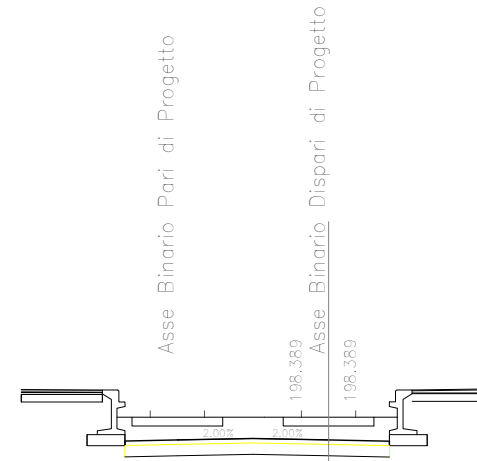

1:200

Qt. rif. 173.000

Quote Progetto														
Quote Terreno	-190.84	-192.82	-191.32	-191.06	-189.59	-189.49	-192.46	-192.26	-190.57	-189.84	-189.46	-186.69	-189.01	-186.84
Distanze Parz. Progetto														
Distanze Progetto														
Distanze Terreno	-33.14	-26.09	-24.61	-22.86	-19.66	-1.35	-1.11	0.00	3.18	16.32	16.34	31.08	31.66	32.17

PAVIMENTAZIONI	
SUPERCOMPATTATO	2.100 m ²
SUBBALLAST	0.840 m ²

SEZIONE N°: 16
 QT. PROG.: 198.170
 Progr. km: 1500.000
 Dist. prec.: 100.000
 Dist. succ.: 100.000

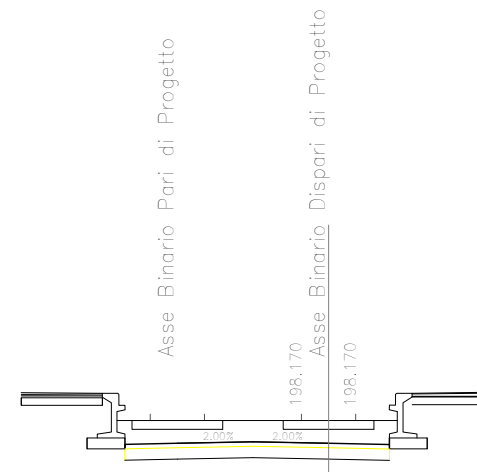

1:200

Qt. rif. 173.000

Quote Progetto				
Quote Terreno	189.15 189.11	189.06 189.22	189.26 189.04	188.93
Distanze Parz. Progetto				
Distanze Progetto				
Distanze Terreno	-29.94 -29.71	-11.29 -11.26	-9.23 -9.21	-0.00

PAVIMENTAZIONI	
SUPERCOMPATTATO	2.100 m ²
SUBBALLAST	0.840 m ²

SEZIONE N°: 17
 QT. PROG.: 197.952
 Progr. km: 1600.000
 Dist. prec.: 100.000
 Dist. succ.: 100.000

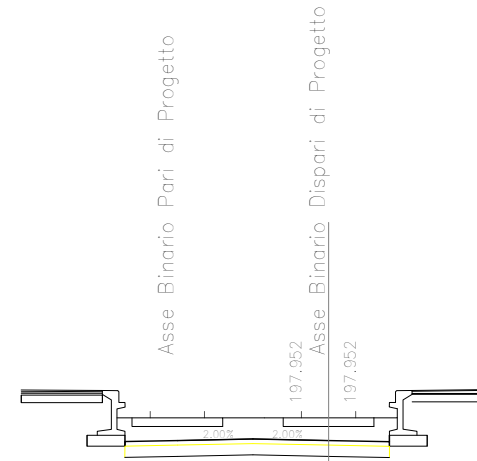

1:200

Qt. rif. 173.000

Quote Progetto				
Quote Terreno	-194.72	-192.45	-188.51	-188.47
Distanze Parz. Progetto				
Distanze Progetto				
Distanze Terreno	-29.20	-22.76	-13.73	-0.00

SEZIONE N°: 18
 QT. PROG.: 197.733
 Progr. km: 1700.000
 Dist. prec.: 100.000
 Dist. succ.: 100.000

1:200

Qt. rif. 188.000

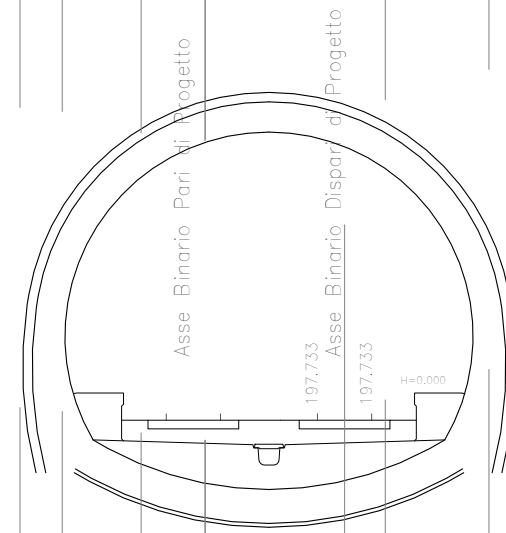

Quote Progetto																																
Quote Terreno	-232.45	-231.53	√230.25 -230.22	-228.00	-225.00	-224.00	-222.38	-219.45	-216.92	-216.79	-216.42	-216.11	-215.73	-215.52	-214.38	√214.01 -214.01	-215.66	-216.14	-217.74	-217.92	-214.68	-212.37	-212.01	-212.41	-212.30	-213.07	-214.55	√214.95 -215.00	-215.89	-216.27	-218.59	√220.00 -220.00
Distanze Parz. Progetto																																
Distanze Progetto																																
Distanze Terreno	-33.50	-31.81	√-30.25 -30.22	-28.35	-25.35	-23.07	-19.70	-15.90	-12.93	-11.94	-10.95	-9.66	-8.59	-7.47	-5.39	√-3.69 -3.69	-0.00	-1.08	-3.82	-5.94	-8.25	-11.47	-13.30	-15.54	-16.43	-19.77	-22.20	√23.96 -24.04	-26.44	-27.73	-30.55	√32.05 -32.08

SEZIONE N°: 19
 QT. PROG.: 197.514
 Progr. km: 1800.000
 Dist. prec.: 100.000
 Dist. succ.: 100.000

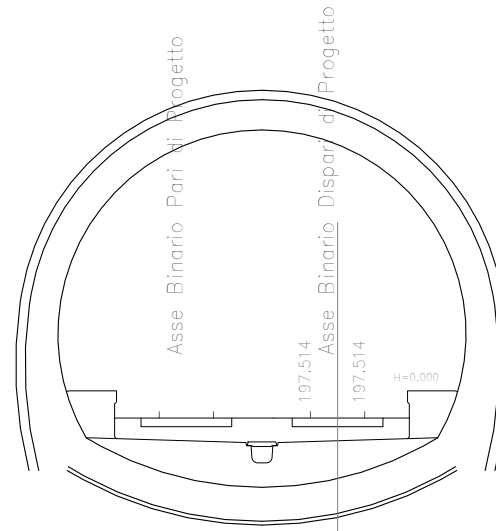

1:200

Qt. rif. 180.000

Quote Progetto						
Quote Terreno	-298.36	-284.75	-282.61	-280.61	-280.00	-275.00
Distanze Parz. Progetto						
Distanze Progetto						
Distanze Terreno	-32.90	-0.00	-5.17	-11.08	-12.36	-27.88

SEZIONE N°: 20
 QT. PROG.: 197.296
 Progr. km: 1900.000
 Dist. prec.: 100.000
 Dist. succ.: 100.000

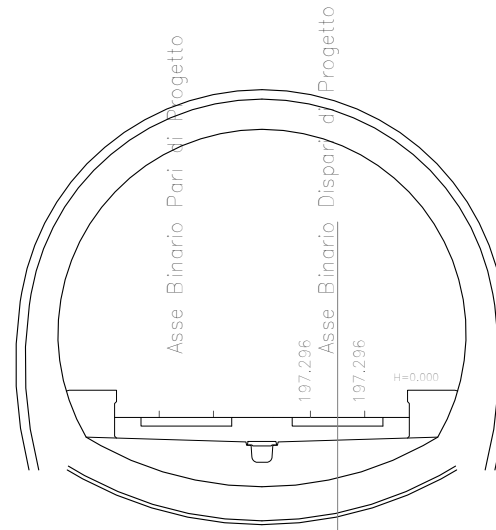

1:200

Qt. rif. 179.000

Quote Progetto					
Quote Terreno	-308.05	-300.00	-292.02	-281.87	-275.00
Distanze Parz. Progetto					
Distanze Progetto					
Distanze Terreno	-23.37	-13.41	-0.00	17.05	-30.46

SEZIONE N°: 21
 QT. PROG.: 197.077
 Progr. km: 2000.000
 Dist. prec.: 100.000
 Dist. succ.: 100.000

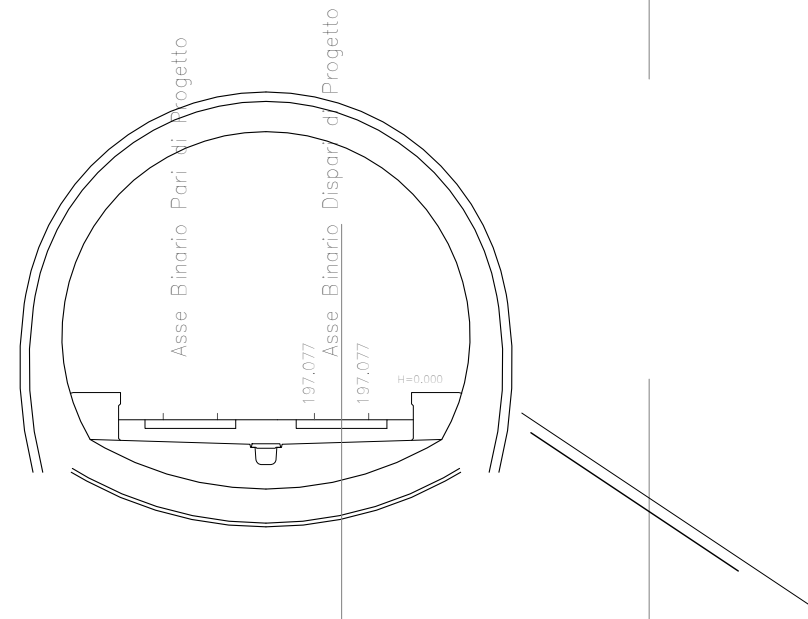

1:200

Qt. rif. 179.000

Quote Progetto			
Quote Terreno		-280,55	-275,00
Distanze Parz. Progetto			
Distanze Progetto			
Distanze Terreno		-0,00	-8,14

-258,61

-33,53

SEZIONE N°: 22
 QT. PROG.: 196.858
 Progr. km: 2100.000
 Dist. prec.: 100.000
 Dist. succ.: 100.000

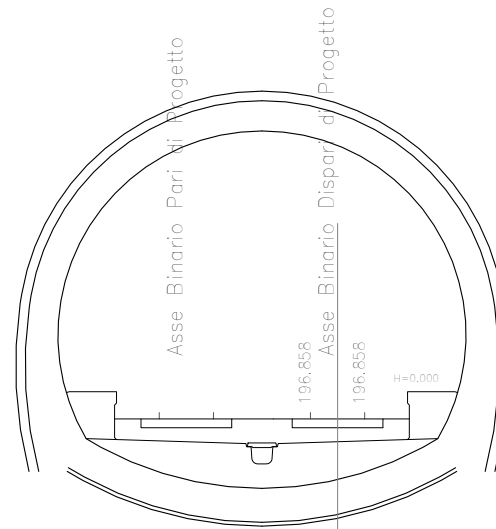

1:200

Qt. rif. 179.000

Quote Progetto								
Quote Terreno	-275.00	-266.95	-261.05	-253.99	-252.15	-250.00	-248.64	
Distanze Parz. Progetto								
Distanze Progetto								
Distanze Terreno	-23.75	-9.71	-0.00	11.61	16.27	22.40	24.38	

SEZIONE N°: 23
 QT. PROG.: 196.640
 Progr. km: 2200.000
 Dist. prec.: 100.000
 Dist. succ.: 100.000

1:200

Qt. rif. 184.000

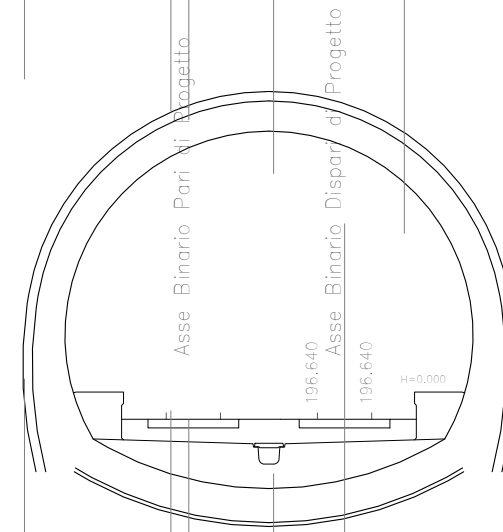

Quote Progetto																								
Quote Terreno	-237.90		-234.00	-232.63	-230.16			-219.00		-217.33 -216.84	-214.00	-212.28	-210.84		-206.42		-203.00		-200.46		-195.79 -195.71		-191.98	
Distanze Parz. Progetto																								
Distanze Progetto																								
Distanze Terreno	-31.92		-25.14	-23.47	-21.33			-8.47		-4.60 -4.12	-1.88	0.00	-1.58		-6.71		-13.44		-18.44		-25.37 -25.76		-32.50	

SCAVI E BONIFICHE	
SOSTITUZIONE TERRENI	8.792 m ²
SCAVO DI SBANCAMENTO	5.975 m ²
SCAVO PER FOSSI DI GUARDIA CANALETTE E FOSSI DISPERDENTI	0.046 m ²
RILEVATI	
RILEVATO FERROVIARIO	76.586 m ²
TERRENO VEGETALE	5.785 m ²
PAVIMENTAZIONI	
SUPERCOMPATTATO	3.937 m ²
SUBBALLAST	1.535 m ²

SEZIONE N°: 25
 QT. PROG.: 195.785
 Progr. km: 2400.000
 Dist. prec.: 100.000
 Dist. succ.: 100.000

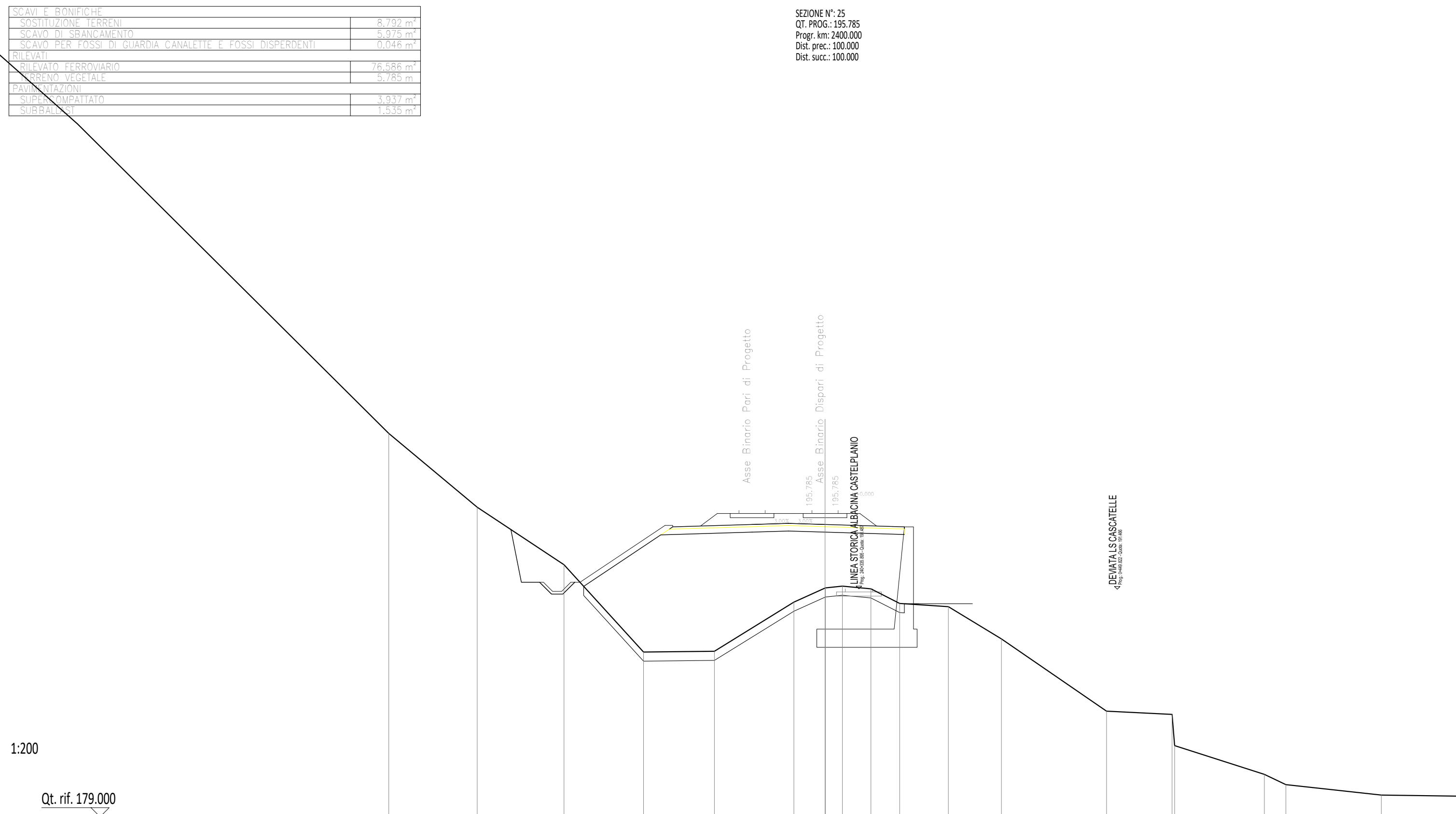

1:200

Qt. rif. 179.000

Quote Progetto				194.74 191.85	191.85	191.20	191.85 191.62	194.44 194.46	194.59	194.65	194.59	190.67 190.67												
Quote Terreno		200.00	195.96			192.81		188.03		188.07	194.59	190.76	191.53	191.64	191.49	190.69	190.51	188.74	184.78	184.61 182.90	181.32	180.76	180.19	
Distanze Parz. Progetto				0.58 1.00	1.92		4.96			6.35			7.15											
Distanze Progetto				-17.23 -16.65	-15.65	-15.00	-14.38	-13.73 -13.23	-9.01 -8.35	-4.00	-2.00	-0.00	-0.95	-2.52	-4.09	-5.15	-6.76	-9.67	-15.44	19.03 19.17	-24.09	-25.27	-30.50	
Distanze Terreno		-23.92	-19.07			-14.31		-9.95		-6.07		-1.71	0.00	0.95	2.52	4.09	6.76	9.67	15.44	19.03 19.17	24.09	25.27	30.50	

SCAVI E BONIFICHE	
SOSTITUZIONE TERRENI	3.594 m ²
SCAVO DI SBANCAMENTO	38.872 m ²
RILEVATI	
RILEVATO FERROVIARIO	38.204 m ²
PAVIMENTAZIONI	
SUPERCOMPATTATO	3.810 m ²
SUBBALLAST	1.524 m ²

SEZIONE N°: 26
 QT. PROG.: 195.254
 Progr. km: 2500.000
 Dist. prec.: 100.000
 Dist. succ.: 100.000

1:200

Qt. rif. 172.000

Quote Progetto																											
Quote Terreno	-203.56	-201.84	-201.73	-201.70	-199.35	-199.35	-194.35	-193.75	-193.75	-194.06	-194.12	-194.06	-191.17	-190.69	-190.65	-190.72	-190.48	-194.35	-194.35	-190.32	-188.02	-182.59	-179.10				
Distanze Parz. Progetto			0.70	1.56	2.00	3.33	0.50	0.70		8.35			6.85			3.50											
Distanze Progetto			-17.17	-16.45	-14.86	-12.88	-9.55	-9.05	-8.35	-4.00	-2.00	-0.00				-4.35	-4.85		-8.35								
Distanze Terreno	-30.22	-19.47				-13.17				-8.85	-6.16	-5.51	-3.52	-2.39	-0.07	-0.83	1.82	3.34	3.67	-4.85		-8.35	-12.55	-13.60	-18.59		-29.76

Asse Binario Pari di Progetto

LINEA STORICA ALBACINA CASTELPLANO

Asse Binario Dispari di Progetto

DEVIATA LS CASCATELLE

SCAVI E BONIFICHE	
SCAVO DISBANCAMENTO	150.716 m ²
RILEVATI	
RILEVATO FERROVIARIO	8.495 m ²
TERRENO VEGETALE	4.989 m
PAVIMENTAZIONI	
SUPERCOMPATTATO	3.881 m ²
SUBBALLAST	1.524 m ²
PAVIMENTAZIONE STRADELLO FS	1.332 m ²

SEZIONE N°: 27
 QT. PROG.: 194.723
 Progr. km: 2600.000
 Dist. prec.: 100.000
 Dist. succ.: 100.000

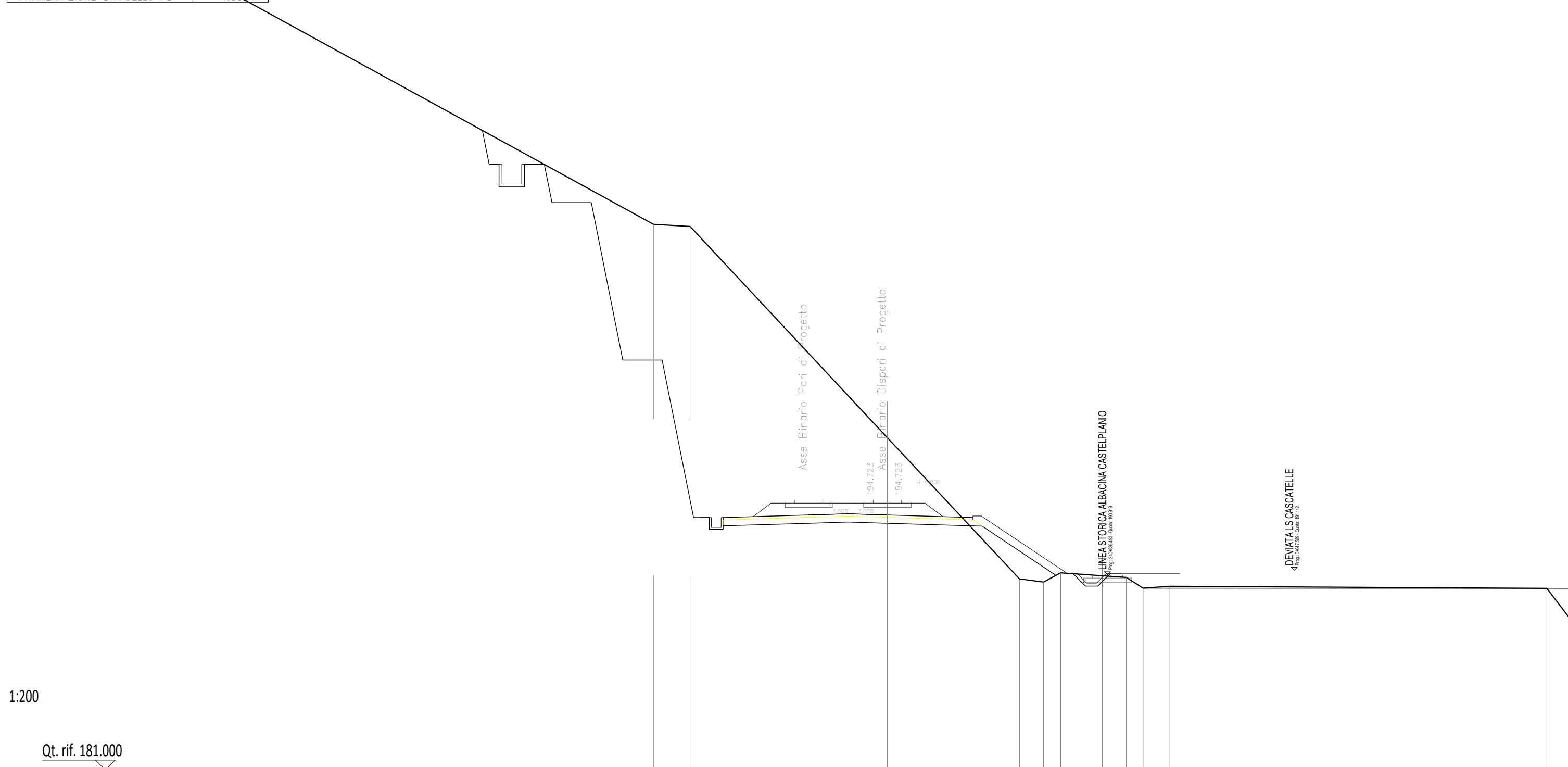

1:200

Qt. rif. 181.000

Quote Progetto	-213.49	-211.76	-210.61	-210.61	-211.76	-211.76	-209.82	-209.82	-201.82	-201.82	-201.82	-193.82	-193.22	-193.22	-193.53	-193.59	-193.53	-193.40	-193.39	-190.89	-190.99	-190.34	-190.99	-190.99	-190.24	-190.24	-190.33	-190.23
Quote Terreno											208.72	208.61					197.88			190.71	190.54	191.01		190.78	190.24	190.33		190.23
Distanze Parz. Progetto		0.50	1.30		1.00		2.00	1.60	2.00	1.60		0.50	0.70		6.35		6.35			4.65		1.92	0.50	1.15				
Distanze Progetto	-20.59	-19.74	-19.74	-18.44	-18.44	-17.44	-17.05	-15.05	-13.45	-11.45	-9.85	-9.05	-8.35		-4.00	-2.00	-0.00	-4.35	-4.82	-8.57	-9.42	-10.07	-10.70	-11.35	-11.85	-13.00	-14.36	
Distanze Terreno											-11.89	-10.03					-0.00			-6.71	-7.94	-8.81		-12.14	-13.00	-14.36		-33.52

SCAVI E BONIFICHE	
SCAVO DI SBANCAMENTO	145.209 m ²
PAVIMENTAZIONI	
SUPERCOMPATTATO	2.340 m ²
SUBBALLAST	0.936 m ²

SEZIONE N°: 28
 QT. PROG.: 194.176
 Progr. km: 2700.000
 Dist. prec.: 100.000
 Dist. succ.: 100.000

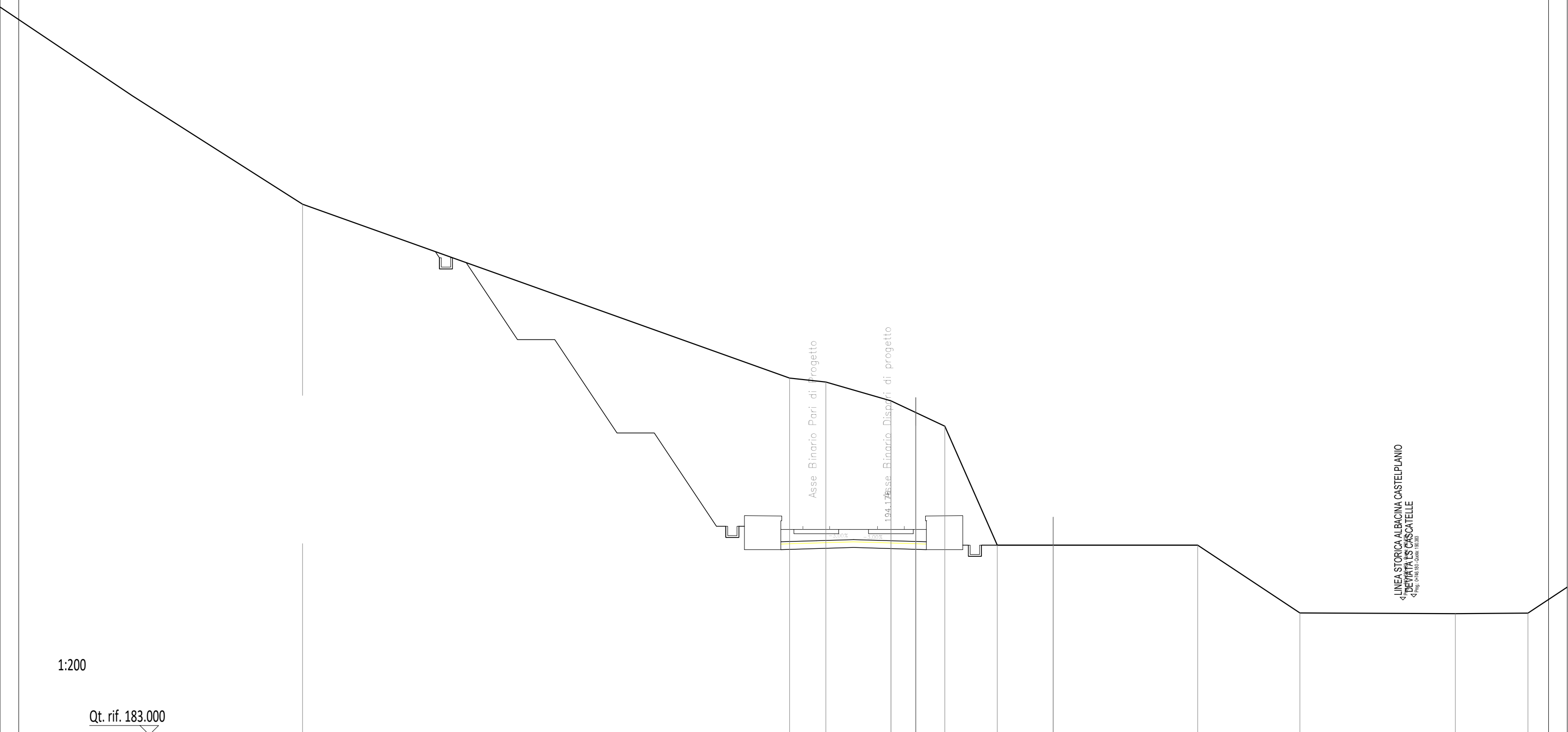

1:200

Qt. rif. 183.000

LINEA STORICA ALBACINA CASTELPLANIO - DEVIATA LS CASCIATELE

Quote Progetto			-208.89	-207.97	-208.31	-204.18	-204.18	-199.18	-199.18	194.18	194.18	194.18	192.92		193.04	192.98	192.92	193.16	193.16	192.56	193.16			193.16			
Quote Terreno	-211.44												202.12	201.90	200.90	199.54				193.16			189.53				189.49
Distanze Parz. Progetto			0.70	0.73	2.75	2.00	3.33	2.00	3.33	0.50	0.70		6.15	2.00		4.15				0.70	0.85		10.74				
Distanze Progetto		-24.42	-23.50	-22.77	-20.02	-18.02	-14.68	-12.68		-9.35	-8.85	-8.15	-7.85	-5.90		-2.00	-0.00	-1.90	3.85	4.15	4.85	-5.70		16.44			
Distanze Terreno	-31.54													-5.43	-3.49	-0.00	-2.89						16.44			21.92	30.25

SCAVI E BONIFICHE	
SCAVO DI SBANCAMENTO	150.879 m ³
PAVIMENTAZIONI	
SUPERCOMPATTATO	2.340 m ²

SEZIONE N°: 30
 QT. PROG.: 192.398
 Progr. km: 2900.000
 Dist. prec.: 100.000
 Dist. succ.: 56.494

1:200

Qt. rif. 180.000

Quote Progetto				199.77	196.56	196.56	191.56	191.56	191.56	191.14	191.26	191.20	191.14	191.39	191.39	190.79	191.39			191.39
Quote Terreno		-200.73		-200.22		199.04			198.61		197.14	196.48	195.51		195.41			-193.95		
Distanze Parz. Progetto					2.14	2.00	3.33	0.50	0.70	6.15	2.00	4.15		0.70	0.85			27.06		
Distanze Progetto				-16.82	-14.68	-12.68	-9.35	-8.85	-8.15	-5.90	-2.00	-0.00	-1.90	-3.85	-4.15	-4.85	-5.70			-32.76
Distanze Terreno		-29.59		-19.12		-13.10			-6.65		-1.27	-0.00	-1.89		-8.16			-17.80		

Asse Binario Pari di Progetto

Asse Binario Dispari di progetto

SEZIONE N°: 31
 QT. PROG.: 191.888
 Progr. km: 2956.494
 Dist. prec.: 56.494
 Dist. succ.: 143.506

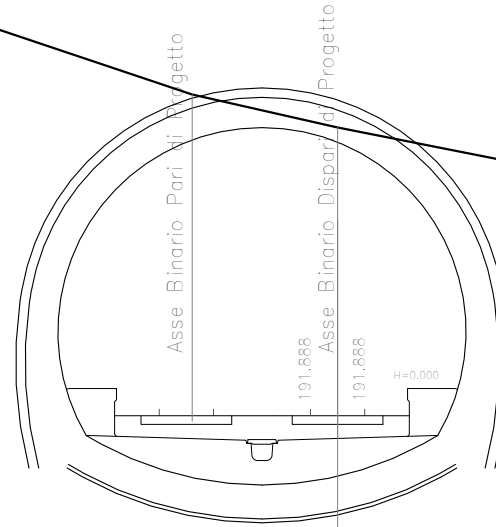

1:200

Qt. rif. 175.000

Quote Progetto											
Quote Terreno		-203.34	-200.21	-199.34	-197.41	-196.83	-195.32	-195.01	-192.59	-192.41	-193.82
Distanze Parz. Progetto											
Distanze Progetto											
Distanze Terreno		-13.16	-3.85	-0.00	-9.79	-13.86	-20.83	-21.59	-24.29	-27.27	-29.87

SEZIONE N°: 32
 QT. PROG.: 190.593
 Progr. km: 3100.000
 Dist. prec.: 143.506
 Dist. succ.: 100.000

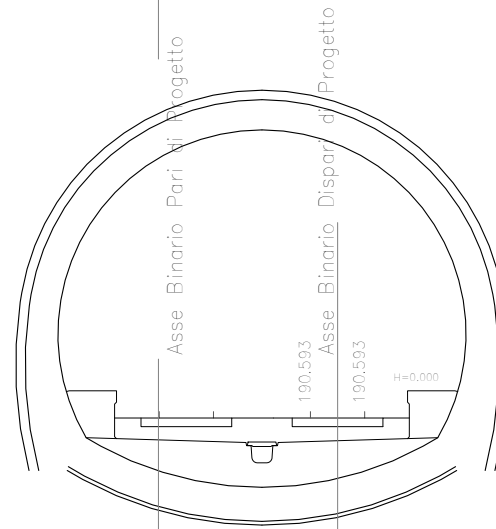

1:200

Qt. rif. 173.000

Quote Progetto						
Quote Terreno	-250.00	-236.23	-235.74	-227.07	-225.00	-222.60
Distanze Parz. Progetto						
Distanze Progetto						
Distanze Terreno	-26.66	-4.74	-0.00	-16.51	-20.17	-23.30

SEZIONE N°: 33
 QT. PROG.: 189.691
 Progr. km: 3200.000
 Dist. prec.: 100.000
 Dist. succ.: 100.000

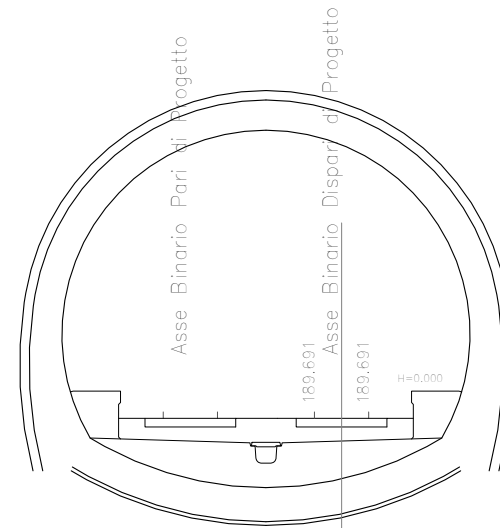

1:200

Qt. rif. 172.000

Quote Progetto						
Quote Terreno		-250.00	-236.81	-234.24	-225.00	-215.92
Distanze Parz. Progetto						
Distanze Progetto						
Distanze Terreno		-14.35	-0.00	-5.85	-19.42	-31.31

SEZIONE N°: 34
 QT. PROG.: 189.047
 Progr. km: 3300.000
 Dist. prec.: 100.000
 Dist. succ.: 100.000

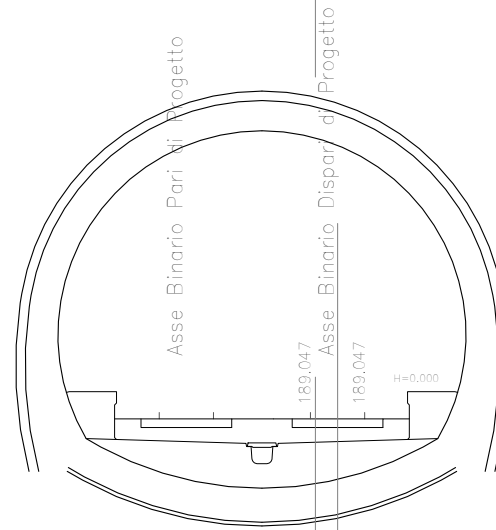

1:200

Qt. rif. 171.000

Quote Progetto	
Quote Terreno	-250.00 -249.52 -225.68
Distanze Parz. Progetto	
Distanze Progetto	
Distanze Terreno	-0.59 -0.00 -29.05

SEZIONE N°: 35
 QT. PROG.: 188.879
 Progr. km: 3400.000
 Dist. prec.: 100.000
 Dist. succ.: 100.000

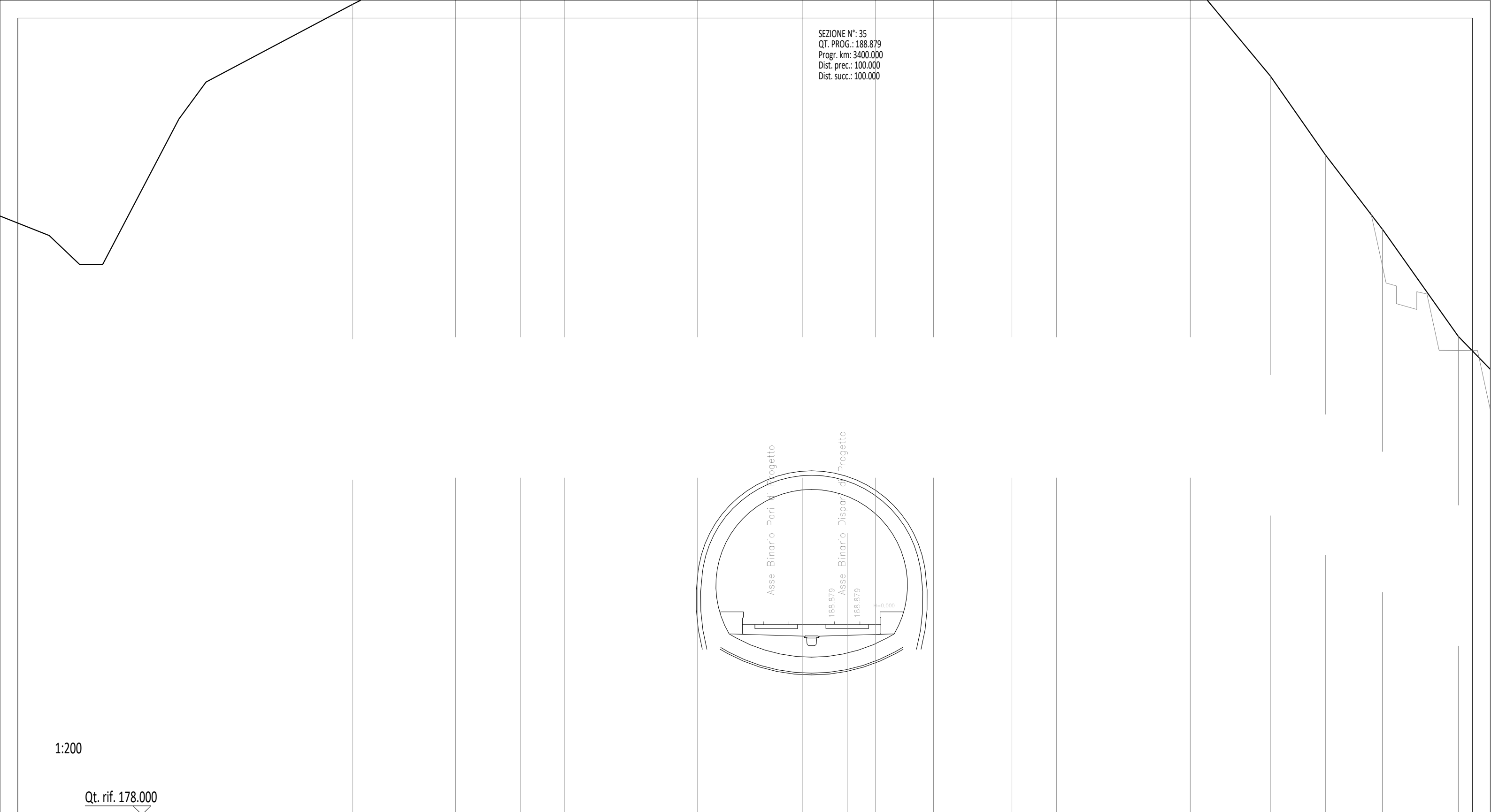

1:200

Qt. rif. 178.000

Quote Progetto																				
Quote Terreno		-223.67	-226.64	-228.83	-229.46		-232.69	-234.05	-234.26	-234.39	-234.26	-233.65	-231.93		-225.06	-219.63	-215.19	-211.00	-211.00	
Distanze Parz. Progetto																				
Distanze Progetto																				
Distanze Terreno		-27.87	-22.07	-18.40	-15.92		-8.43	-2.50	0.00	1.60	4.87	9.29	11.79		19.34	23.85	26.95	30.16	30.17	

SEZIONE N°: 36
 QT. PROG.: 188.711
 Progr. km: 3500.000
 Dist. prec.: 100.000
 Dist. succ.: 100.000

1:200

Qt. rif. 177.000

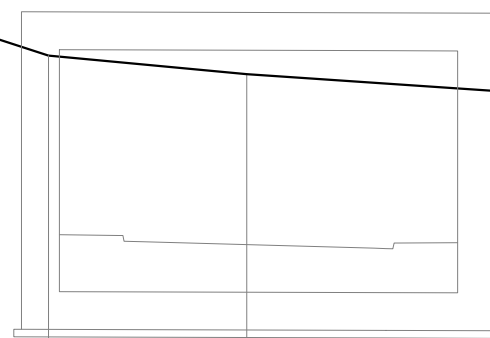
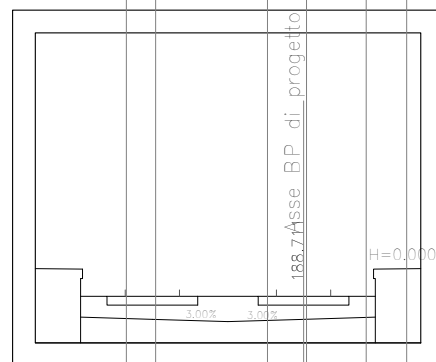

LINEA STORICA ALBACINA CASTELPLANO
Prog. 41+425.94 - Quota 186.08

Quote Progetto																															
Quote Terreno	-217.48	-216.24			210.29	208.97	208.56		205.67			199.00	198.85		198.81	199.17	199.20		198.16	197.79		195.35	194.80		194.31		193.56			188.47	187.15
Distanze Parz. Progetto																															
Distanze Progetto																															
Distanze Terreno	-32.01	-29.23			-20.77	-19.41	-18.54		-14.63			-4.69	-3.92		-0.96	0.00	0.08		1.66	2.73		6.13	7.80		13.05		24.14			30.68	31.14

SEZIONE N°: 37
 QT. PROG.: 188,544
 Progr. km: 3600,000
 Dist. prec.: 100,000
 Dist. succ.: 100,000

1:200

Qt. rif. 178.000

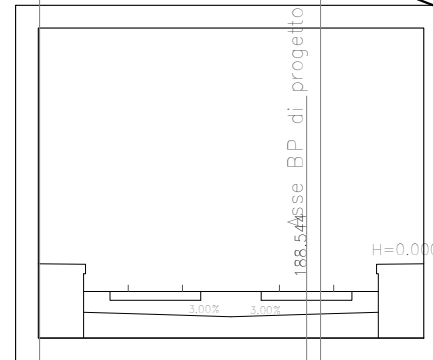

LINEA STORICA ALBACINA CASTELPIANO
 4 Proj. H=0.00, RB=0.00, QT=188,571

Quote Progetto															
Quote Terreno	-212,69	-204,46	-200,23	-197,26 -197,10	-194,39	-191,53	-191,01 -191,24 -189,98 -189,15 -186,62	-187,02	-186,69	-186,02					
Distanze Parz. Progetto															
Distanze Progetto															
Distanze Terreno	-28,20	-14,07	-7,06	-0,00 -0,37	-7,36	-14,07	-19,69 -20,41 -21,13 -21,92 -22,48	-24,50	-27,03	-28,36					

SEZIONE N°: 38
 QT. PROG.: 188.614
 Progr. km: 3700.000
 Dist. prec.: 100.000
 Dist. succ.: 100.000

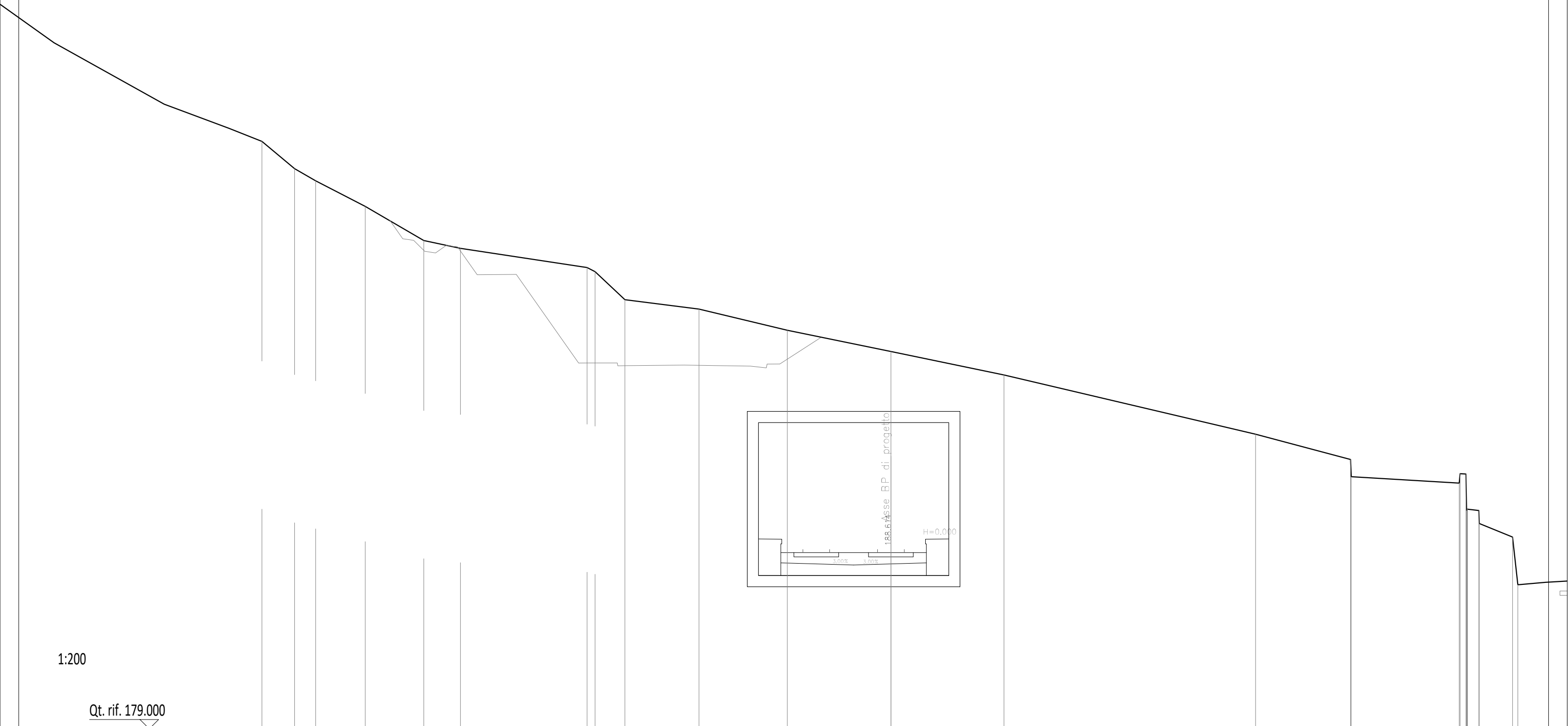

1:200

Qt. rif. 179.000

Quote Progetto																						
Quote Terreno	-210.48	-209.02	-208.37	-207.00	-205.17	-204.75	-203.72	-203.56	-202.00	-201.50	-200.36	199.22	197.97	194.79	193.44	192.51	192.17	190.77	190.70	190.00	189.28	186.72
Distanze Parz. Progetto																						
Distanze Progetto																						
Distanze Terreno	-33.71	-31.96	-30.84	-28.18	-25.04	-23.07	-16.29	-15.66	-14.26	-10.29	-5.55	0.00	-6.06	-19.55	24.64	24.67	-30.46	-30.90	-31.51	-31.53	-33.32	-33.60

SEZIONE N°: 40
 QT. PROG.: 190.707
 Progr. km: 3900.000
 Dist. prec.: 100.000
 Dist. succ.: 100.000

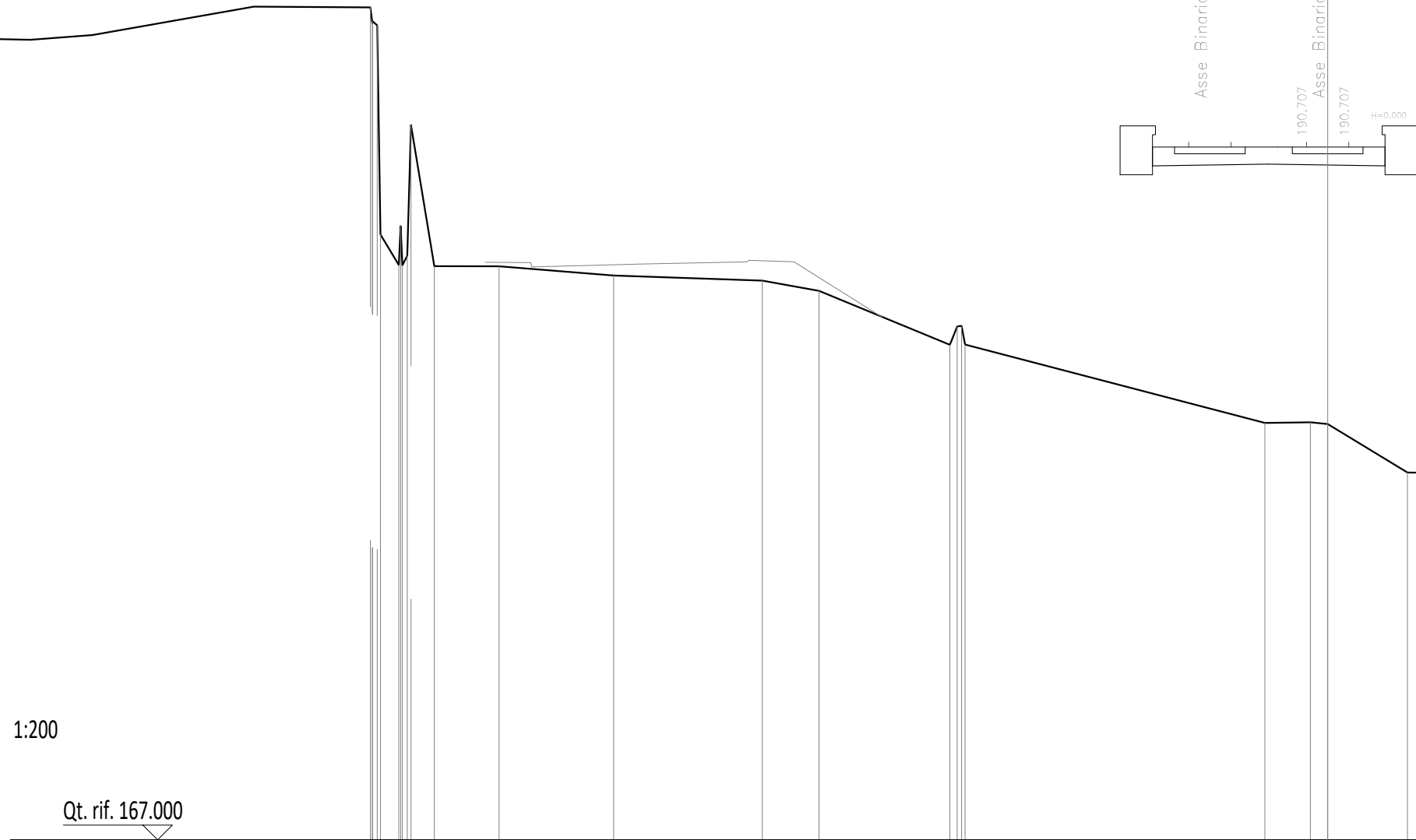

Quote Progetto	
Quote Terreno	195.28 186.53 191.28 186.49 186.49 186.17 186.00 185.65 183.82 183.83 181.17 181.18 181.13 181.13 179.48
Distanze Parz. Progetto	
Distanze Progetto	
Distanze Terreno	-32.52 -31.56 -31.14 -30.35 -28.15 -24.26 -19.21 -17.28 -12.83 -12.32 -2.13 -0.59 0.00 0.00 -2.71

SEZIONE N°: 41
 QT. PROG.: 191.851
 Progr. km: 4000.000
 Dist. prec.: 100.000
 Dist. succ.: 100.000

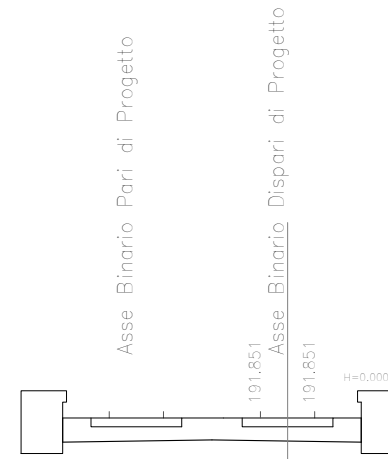

Quote Progetto								
Quote Terreno	181.90	180.61	180.10		179.50	179.43	179.06	178.86
Distanze Parz. Progetto								
Distanze Progetto								
Distanze Terreno	-32.67	-28.66	-22.62		-1.68	0.00	8.03	-33.68

PAVIMENTAZIONI	
SUPERCOMPATTATO	2,664 m ²
SUBBALLAST	0,936 m ²

SEZIONE N°: 42
 QT. PROG.: 192.531
 Progr. km: 4100.000
 Dist. prec.: 100.000
 Dist. succ.: 100.000

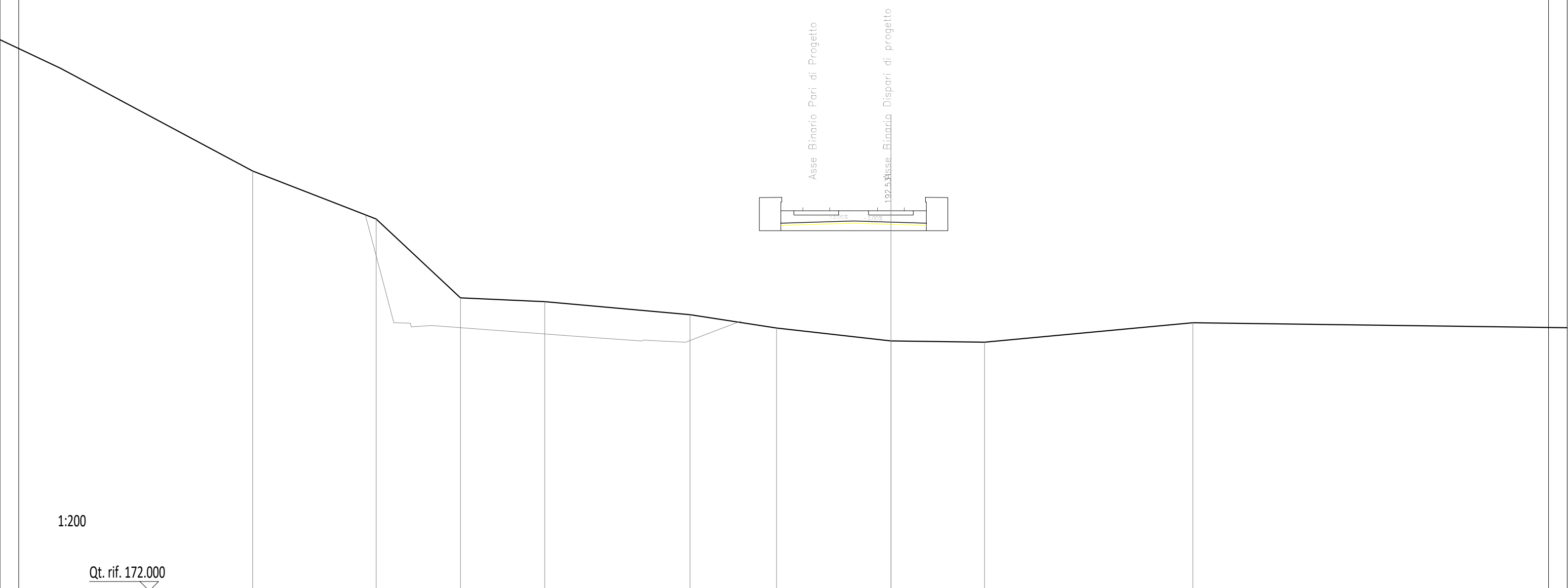

Quote Progetto									
Quote Terreno		191.92	187.69	187.49	186.79	186.08	185.39	185.32	186.36
Distanze Parz. Progetto									
Distanze Progetto									
Distanze Terreno		-27.59	-23.07	-18.55	-10.77	-6.13	0.00	5.02	16.18

SEZIONE N°: 43
 QT. PROG.: 192.172
 Progr. km: 4200.000
 Dist. prec.: 100.000
 Dist. succ.: 100.000

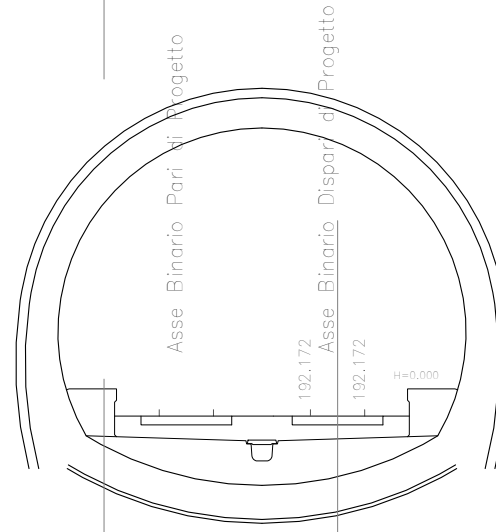

1:200

Qt. rif. 174.000

Quote Progetto	
Quote Terreno	-266.73 -266.68 -267.24 -267.12 -266.71 -266.78 -267.61 -266.71 -268.24 -269.21 -269.39 -268.31 -267.09 -266.14 -264.91 -261.06 -257.56 -250.11 -246.76 -246.18 -247.15 -246.04 -244.69
Distanze Parz. Progetto	
Distanze Progetto	
Distanze Terreno	-33.52 -32.54 -31.80 -30.22 -28.41 -27.73 -26.20 -23.14 -22.07 -18.06 -16.23 -14.56 -10.60 -9.04 -6.18 -0.00 -5.61 -18.43 -22.04 -22.96 -26.09 -27.73 -32.14

SEZIONE N°: 44
 QT. PROG.: 191.021
 Progr. km: 4300.000
 Dist. prec.: 100.000
 Dist. succ.: 100.000

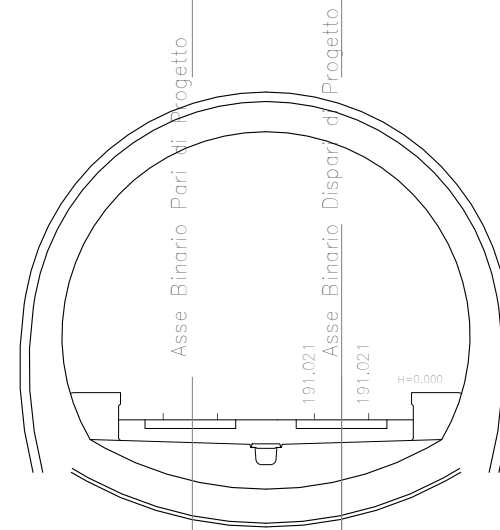

1:200

Qt. rif. 173.000

Quote Progetto									
Quote Terreno	-269.24	-269.45	-269.44	-269.74	-270.03	-271.26	-272.18	-273.67	-274.24
Distanze Parz. Progetto									
Distanze Progetto									
Distanze Terreno	-32.90	-28.20	-18.19	-3.95	0.00	7.43	19.21	25.01	31.41

SEZIONE N°: 45
 QT. PROG.: 189.821
 Progr. km: 4400.000
 Dist. prec.: 100.000
 Dist. succ.: 100.000

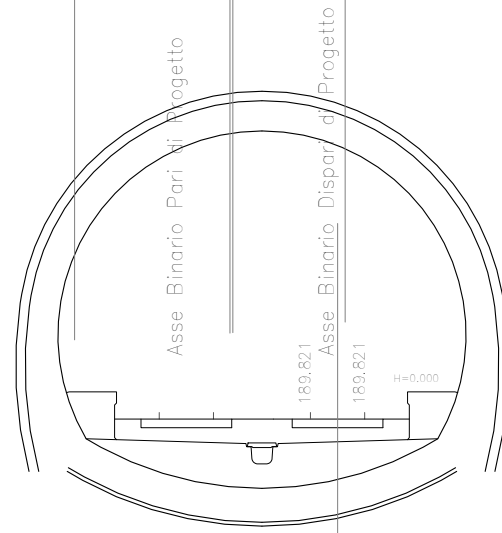

1:200

Qt. rif. 174.000

Quote Progetto																				
Quote Terreno	-203.25	-203.44	-203.12	-202.74	-202.75	-202.29	-201.78	-201.55	√ 201.91 √ 201.93	√ 202.46 √ 202.50	-201.81	-201.00	-201.35	-201.45	-201.81	-201.97	-201.35			
Distanze Parz. Progetto																				
Distanze Progetto																				
Distanze Terreno	-32.26	-29.18	-27.11	-23.00	-17.90	-15.57	-10.93	-6.96	√ -2.85 √ -2.77	√ 0.00 √ 0.20	-5.37	-8.69	-15.37	-20.01	-24.14	-27.42	-31.55			

SEZIONE N°: 46
 QT. PROG.: 188.621
 Progr. km: 4500.000
 Dist. prec.: 100.000
 Dist. succ.: 100.000

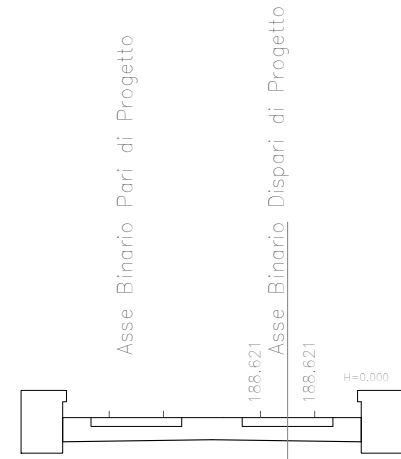

1:200

Qt. rif. 162.000

Quote Progetto													
Quote Terreno	176.16	176.72	177.09	177.25	177.83	177.44	177.81	178.36	178.16	176.70	176.01	175.92	
Distanze Parz. Progetto													
Distanze Progetto													
Distanze Terreno	-33.41	-18.15	-0.91	-0.00	-3.19	-5.89	-6.21	-7.41	-11.16	-18.51	-24.37	-28.45	

SEZIONE N°: 47
 QT. PROG.: 187.421
 Progr. km: 4600.000
 Dist. prec.: 100.000
 Dist. succ.: 100.000

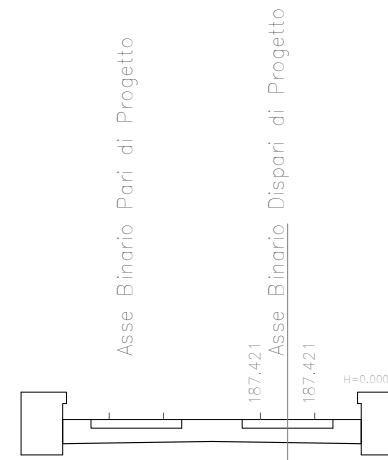

1:200

Qt. rif. 160.000

Quote Progetto	
Quote Terreno	175.59 175.66 176.63 175.81 175.28 175.46
Distanze Parz. Progetto	
Distanze Progetto	
Distanze Terreno	0.00 15.74 21.34 23.57 24.32 28.73

RILEVATI	
RILEVATO FERROVIARIO	9.928 m ²
TERRENO VEGETALE	6.746 m ²
PAVIMENTAZIONI	
SUPERCOMPATTATO	2.664 m ²
SUBBALLAST	0.936 m ²

SEZIONE N°: 48
 QT. PROG.: 186.221
 Progr. km: 4700.000
 Dist. prec.: 100.000
 Dist. succ.: 100.000

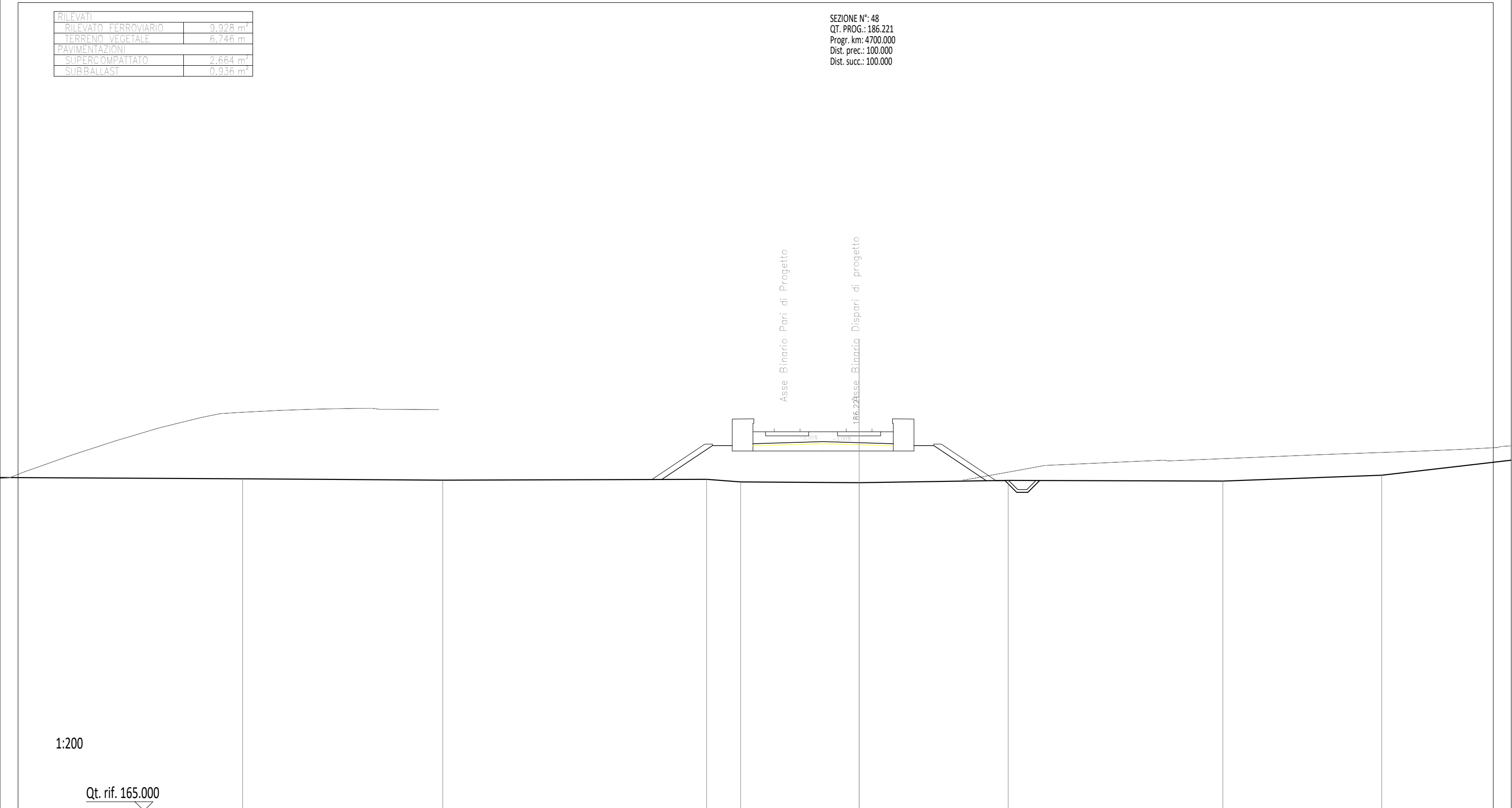

1:200

Qt. rif. 165.000

Quote Progetto				183.40	185.00	185.29	185.29	185.29	185.29	185.00	183.33	183.34	182.69	182.69	183.34		
Quote Terreno		183.36			183.41	183.26		183.22				183.35			183.31		183.64
Distanze Parz. Progetto							12.30				3.04	0.50	1.92				
Distanze Progetto				-10.97	-8.57	-8.15	-7.05		-3.05	-4.15	-4.57	-7.08	-8.11	-8.76	-9.38	-10.03	
Distanze Terreno		-23.15			-8.47	-6.59		-0.00				-8.29			-20.22		-29.05

SEZIONE N°: 49
 QT. PROG.: 185.021
 Progr. km: 4800.000
 Dist. prec.: 100.000
 Dist. succ.: 100.000

1:200

Qt. rif. 175.000

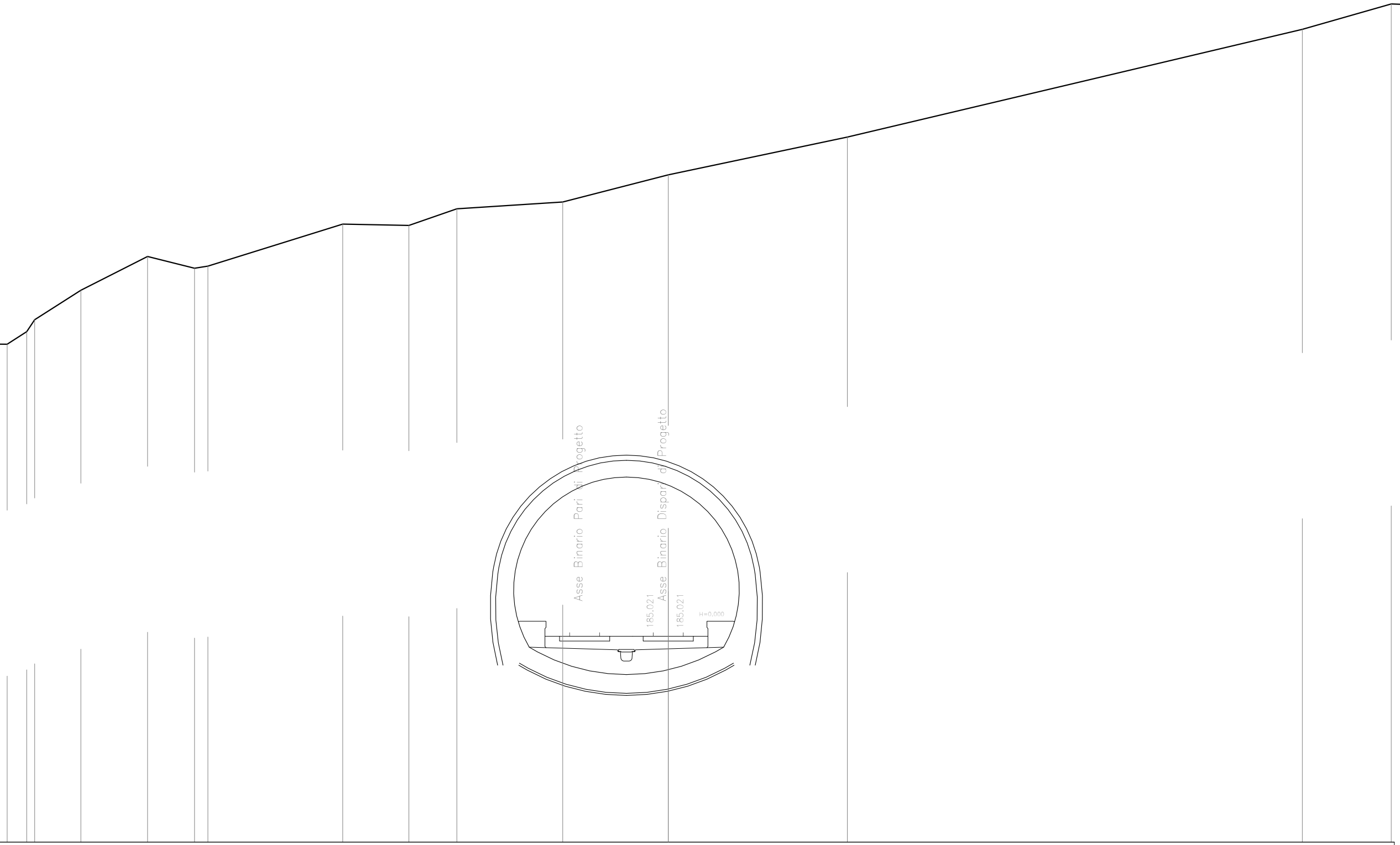

Quote Progetto														
Quote Terreno	-198.83	-199.43	-200.00	-201.41	-203.03	-202.47	-202.57	-204.58	-204.52	-205.31	-205.64	-206.94	-206.74	-213.90
Distanze Parz. Progetto														
Distanze Progetto														
Distanze Terreno	-31.64	-30.70	-30.32	-28.11	-24.92	-22.67	-22.03	-15.58	-12.41	-10.12	-5.05	-0.00	-8.57	-30.35

SEZIONE N°: 50
 QT. PROG.: 183.821
 Progr. km: 4900.000
 Dist. prec.: 100.000
 Dist. succ.: 100.000

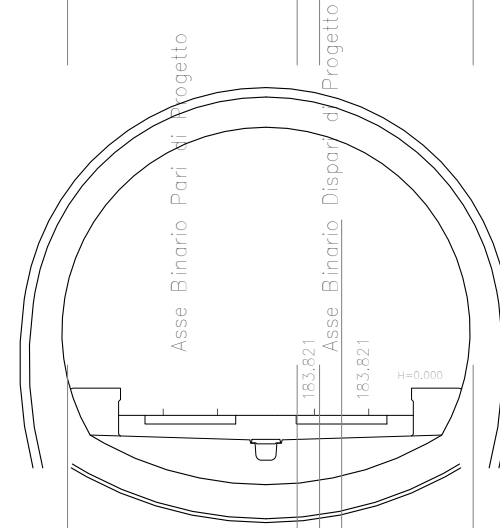

1:200

Qt. rif. 166.000

Quote Progetto																							
Quote Terreno	-261.12	-261.13	-260.69	-261.05	-261.77	-261.99	-263.64	-263.83	-265.32	-266.76	-270.95	-270.86	-271.15	-272.89	-275.00	-300.00	-303.54	-305.46	-307.26	-307.55	-313.70	-315.76	-317.66
Distanze Parz. Progetto																							
Distanze Progetto																							
Distanze Terreno	-33.61	-30.35	-26.69	-24.47	-22.33	-20.32	-17.27	-15.58	-13.51	-7.25	-1.18	-0.58	0.00	3.48	6.28	10.89	15.55	19.50	22.72	23.86	28.50	30.83	32.54

SEZIONE N°: 51
 QT. PROG.: 182.621
 Progr. km: 5000.000
 Dist. prec.: 100.000
 Dist. succ.: 100.000

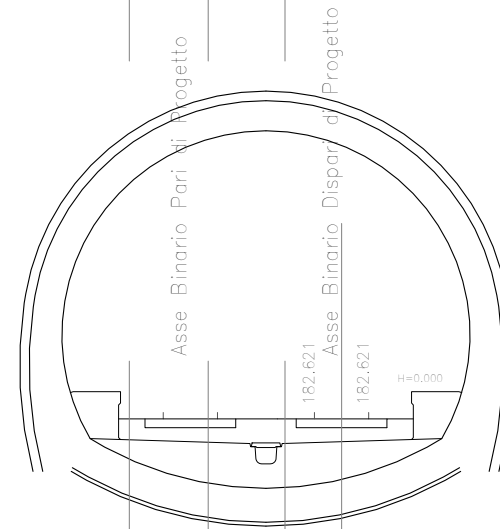

1:200

Qt. rif. 165.000

Quote Progetto														
Quote Terreno	-391.09	-390.01	-389.64	-388.40	-387.05	-387.33	-387.03	-386.36		-378.86		-375.00	-373.58	
Distanze Parz. Progetto														
Distanze Progetto														
Distanze Terreno	-31.00	-23.67	-19.33	-10.70	-5.62	-3.53	-1.50	-0.00		16.68		24.11	26.46	

SEZIONE N°: 52
 QT. PROG.: 181.421
 Progr. km: 5100.000
 Dist. prec.: 100.000
 Dist. succ.: 100.000

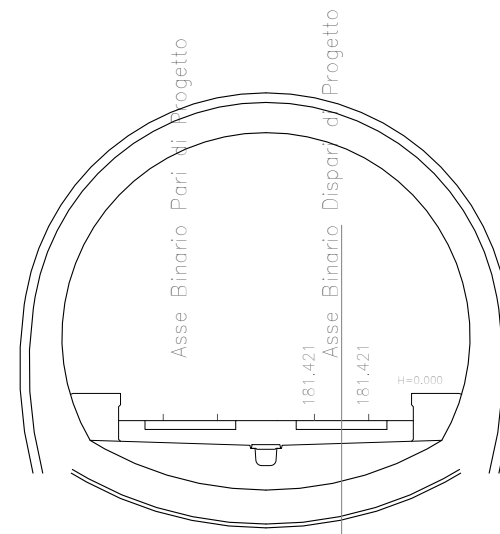

1:200

Qt. rif. 163.000

Quote Progetto				
Quote Terreno	-420,31	-418,36	-410,33	-400,00
Distanze Parz. Progetto				
Distanze Progetto				
Distanze Terreno	-16,50	-9,77	0,00	12,56

SEZIONE N°: 53
 QT. PROG.: 180.221
 Progr. km: 5200.000
 Dist. prec.: 100.000
 Dist. succ.: 100.000

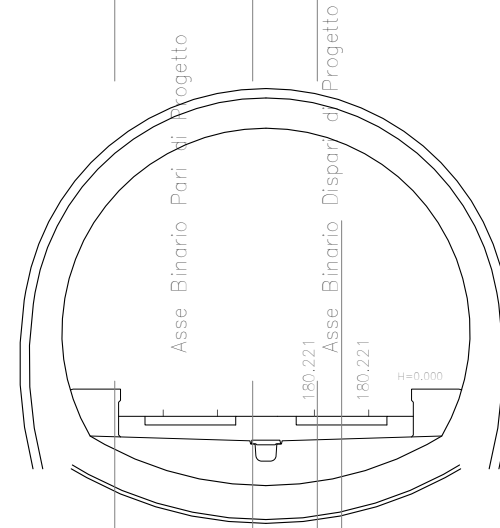

1:200

Qt. rif. 162.000

Quote Progetto																						
Quote Terreno	-336.45	-337.92	-341.16	-342.25	-342.75		-346.55	-346.69		-350.00	-350.00	-350.58	-350.57		-350.53	-350.00	-350.00			-346.90	-346.76	
Distanze Parz. Progetto																						
Distanze Progetto																						
Distanze Terreno	-33.19	-28.09	-23.04	-20.32	-18.29		-12.75	-11.77		-6.00	-2.35	-0.64	0.00		-8.25	-9.12	-11.47			-24.88	-33.24	

SEZIONE N°: 54
 QT. PROG.: 179.118
 Progr. km: 5300.000
 Dist. prec.: 100.000
 Dist. succ.: 100.000

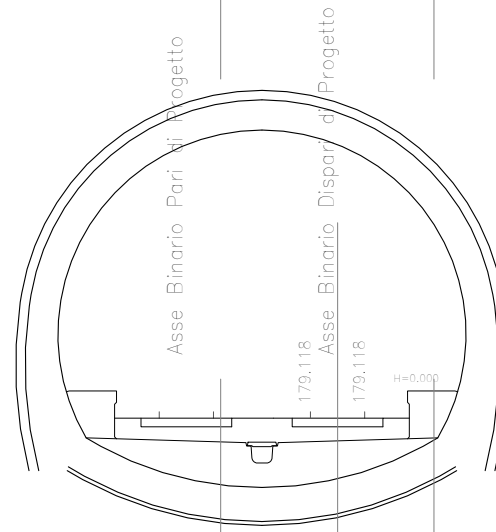

1:200

Qt. rif. 161.000

Quote Progetto																			
Quote Terreno	-255.94	-255.92	-254.73	-254.45	-254.62		-254.53	-254.09	-253.74	-253.73	-253.25		-252.55	-253.87	-253.83	-253.14		-256.37	
Distanze Parz. Progetto																			
Distanze Progetto																			
Distanze Terreno	-32.48	-27.03	-22.93	-17.95	-14.61		-3.09	0.00	2.55	4.57	8.15		16.09	20.62	25.31	28.20		33.05	

SEZIONE N°: 55
 QT. PROG.: 178.335
 Progr. km: 5400.000
 Dist. prec.: 100.000
 Dist. succ.: 100.000

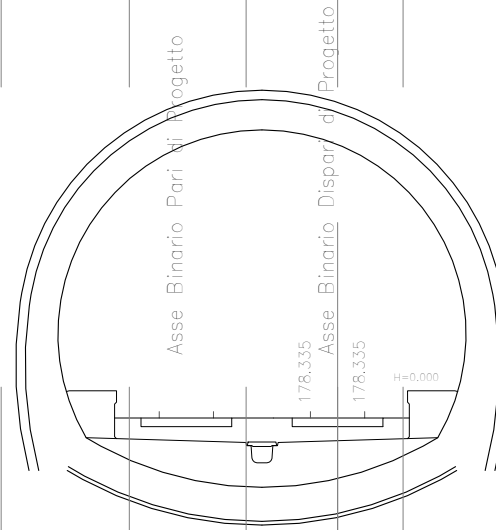

1:200

Qt. rif. 160.000

Quote Progetto																						
Quote Terreno	-288.82	-290.13	-290.58	-290.09	-286.99		-288.32	-287.46	-286.76	-285.60	-285.87	-285.48	-285.28	-287.02	-286.34		-286.60	-287.77	-288.37	-289.63	-291.27	
Distanze Parz. Progetto																						
Distanze Progetto																						
Distanze Terreno	-32.05	-27.24	-24.94	-22.70	-20.56		-10.85	-8.90	-5.51	-2.42	0.00	1.73	4.76	8.42	9.94		17.54	19.78	23.06	27.23	30.41	

SEZIONE N°: 56
 QT. PROG.: 177.592
 Progr. km: 5500.000
 Dist. prec.: 100.000
 Dist. succ.: 100.000

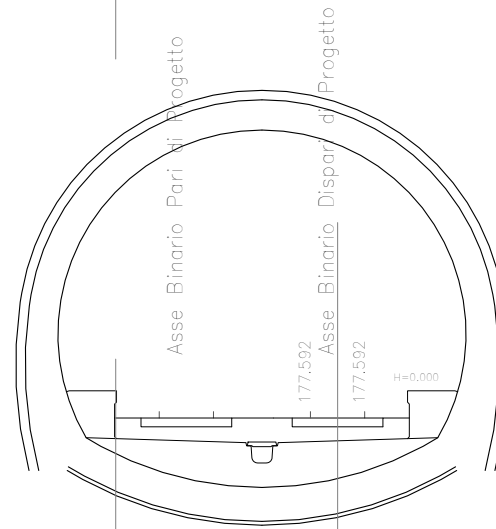

1:200

Qt. rif. 160.000

Quote Progetto														
Quote Terreno	-304.42	-304.40	-309.32	-312.81	-318.71	-320.26	-325.00	-332.87	-350.00	-359.70	-362.86	-367.45		
Distanze Parz. Progetto														
Distanze Progetto														
Distanze Terreno	-30.57	-29.08	-22.56	-17.44	-11.85	-10.02	-5.87	-0.00	12.77	20.21	23.79	33.56		

SEZIONE N°: 57
 QT. PROG.: 176.848
 Progr. km: 5600.000
 Dist. prec.: 100.000
 Dist. succ.: 100.000

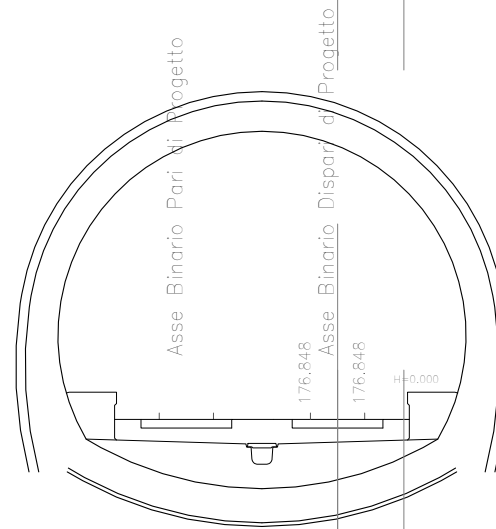

1:200

Qt. rif. 159.000

Quote Progetto	
Quote Terreno	<p>225.00</p> <p>247.77</p> <p>250.00</p> <p>260.03</p> <p>275.00</p> <p>300.00</p> <p>325.00</p> <p>325.00</p>
Distanze Parz. Progetto	
Distanze Progetto	
Distanze Terreno	<p>-17.56</p> <p>-0.00</p> <p>-1.76</p> <p>-5.50</p> <p>-10.47</p> <p>-17.02</p> <p>-25.76</p> <p>-26.26</p>

SEZIONE N°: 58
 QT. PROG.: 176.105
 Progr. km: 5700.000
 Dist. prec.: 100.000
 Dist. succ.: 100.000

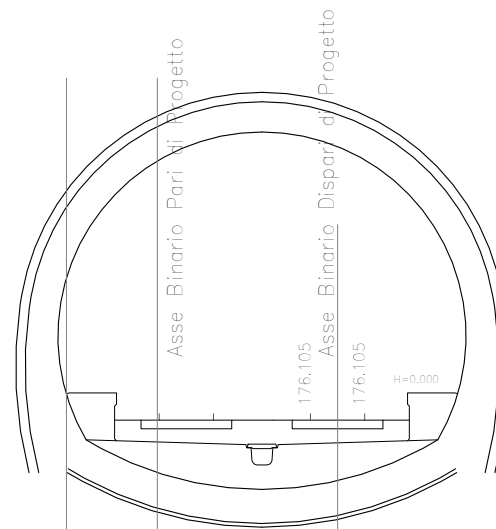

1:200

Qt. rif. 166.000

Quote Progetto											
Quote Terreno	-200.00	-222.12	-225.00	-227.65	-232.64		-250.00	-255.34		-266.17	-268.47
Distanze Parz. Progetto											
Distanze Progetto											
Distanze Terreno	-33.11	-10.33	-7.18	-4.77	-0.00		16.60	-20.28		-28.23	-30.31

SEZIONE N°: 59
 QT. PROG.: 175.362
 Progr. km: 5800.000
 Dist. prec.: 100.000
 Dist. succ.: 100.000

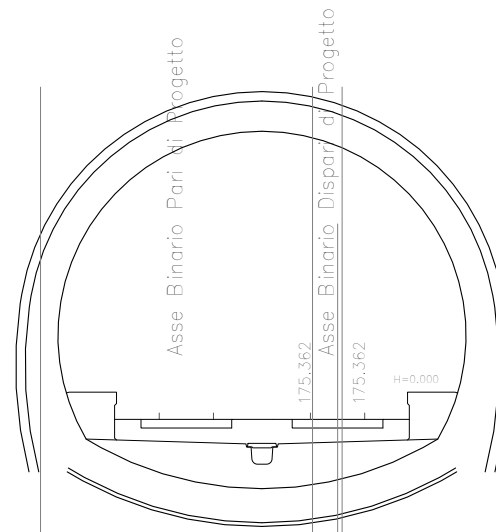

1:200

Qt. rif. 165.000

Quote Progetto					
Quote Terreno	-221.15	-225.00	-241.25	-250.00	-250.00
Distanze Parz. Progetto					
Distanze Progetto					
Distanze Terreno	-22.02	-17.70	-7.86	-0.66	0.12

SEZIONE N°: 60
 QT. PROG.: 174.619
 Progr. km: 5900.000
 Dist. prec.: 100.000
 Dist. succ.: 85.000

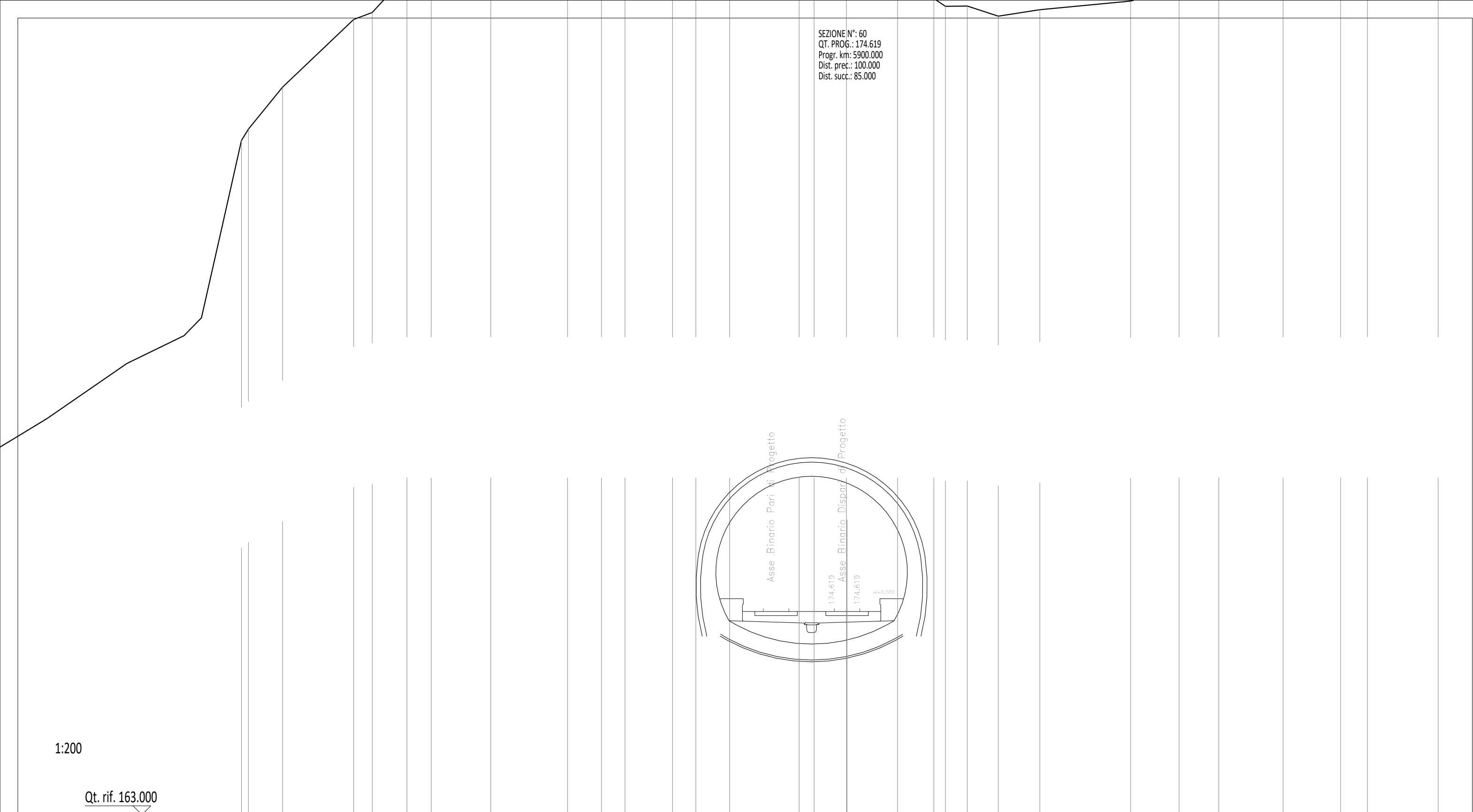

1:200

Qt. rif. 163.000

Quote Progetto																													
Quote Terreno	-201.64	-204.00	-207.82	-208.21	-210.33	-210.61	-210.87	-211.90	-212.54	-212.49	-212.57	-212.34	-212.78	-212.73	-212.37	√ 211.94 211.93	-211.24	-209.00	-208.55	-208.57	-208.00	-208.36	-208.85	-209.64	-209.92	-210.79	-212.83	-213.30	-214.16
Distanze Parz. Progetto																													
Distanze Progetto																													
Distanze Terreno	-33.75	-31.82	-27.81	-26.77	-24.81	-23.45	-20.09	-15.76	-13.85	-12.52	-9.84	-8.53	-6.62	-2.70	-1.86	√ 0.04 0.00	-2.85	-4.89	-5.54	-6.78	-8.53	-10.86	-15.99	-18.72	-20.96	-24.57	-27.82	-29.34	-33.32

SCAVI E BONIFICHE	
SCAVO DI SBANCAMENTO	38,478 m ²
PAVIMENTAZIONI	
SUPERCOMPATTATO	2,340 m ²

SEZIONE N°: 61
 QT. PROG.: 173.988
 Progr. km: 5985.000
 Dist. prec.: 85.000
 Dist. succ.: 115.000



1:200

Qt. rif. 150.000

Quote Progetto									172.73	172.85	172.79	172.73								
Quote Terreno		163.28	164.00	165.43	169.24	172.77	174.67	176.18	177.59	177.97	177.89		177.96	178.14	178.33	177.92	177.48	175.67	174.67	174.68
Distanze Parz. Progetto											2.00									
Distanze Progetto									-5.90	-2.00	-0.00	-1.90								
Distanze Terreno		-29.40	-26.63	-23.03	-17.62	-12.42	-10.10	-7.97	-4.65	-2.36	-0.00	-1.90	-9.54	17.17	-21.74	-25.43	-26.72	-30.06	-32.79	-33.70

SEZIONE N°: 62
 QT. PROG.: 173.133
 Progr. km: 6100.000
 Dist. prec.: 115.000
 Dist. succ.: 100.000

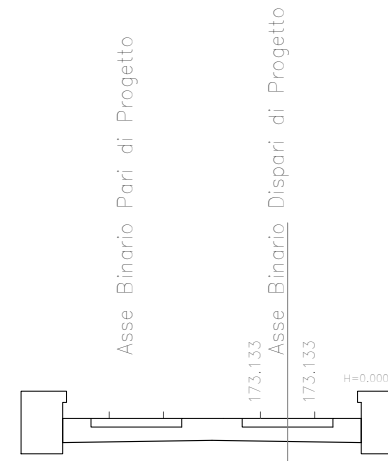

1:200

Qt. rif. 146.000

Quote Progetto										
Quote Terreno	164.49	165.42	163.30	161.74	160.33	160.39		160.48	162.23	161.72
Distanze Parz. Progetto										
Distanze Progetto										
Distanze Terreno	-33.08	-18.53	-13.64	-9.14	-6.48	-0.00		-23.46	31.14	32.57

SEZIONE N°: 63
 QT. PROG.: 172.328
 Progr. km: 6200.000
 Dist. prec.: 100.000
 Dist. succ.: 100.000

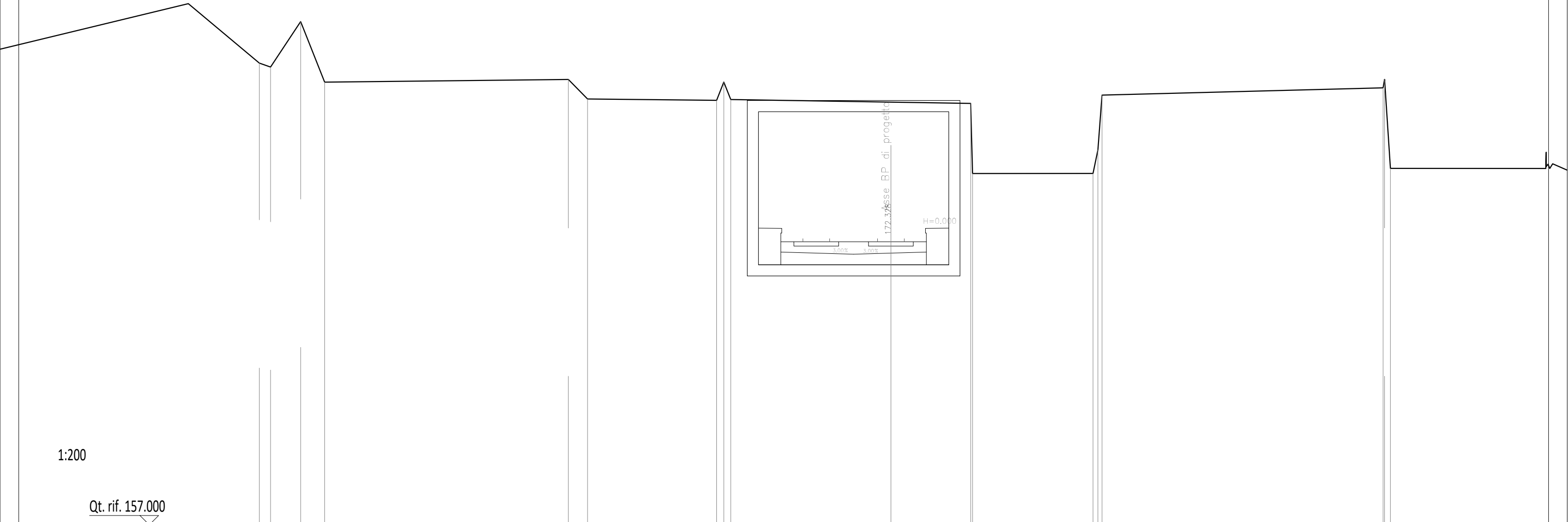

1:200

Qt. rif. 157.000

Quote Progetto	
Quote Terreno	-181.52 -183.95 -180.71 -180.85 -179.81 -179.74 -179.78 -179.64 -179.57 -175.82 -175.82 -180.02 -180.40 -176.09
Distanze Parz. Progetto	
Distanze Progetto	
Distanze Terreno	-33.25 -31.64 -30.35 -17.29 -16.26 -9.34 -8.59 -0.00 4.27 4.37 -10.63 -11.32 -26.38 -26.77

SEZIONE N°: 64
 QT. PROG.: 171.405
 Progr. km: 6300.000
 Dist. prec.: 100.000
 Dist. succ.: 100.000

1:200

Qt. rif. 156.000

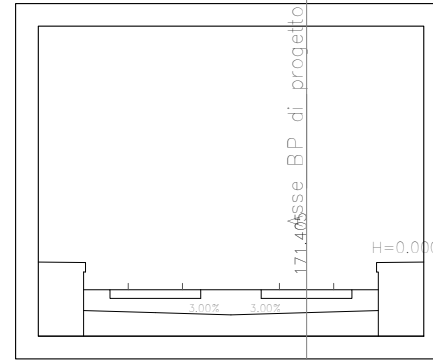

Quote Progetto								
Quote Terreno	-184.23	-184.00	-184.11	-183.91	-183.84	-179.91	-180.24	-178.73
Distanze Parz. Progetto								
Distanze Progetto								
Distanze Terreno	-30.12	-29.50	-9.63	-0.00	-4.91	-16.75	-30.69	-32.74

SEZIONE N°: 65
 QT. PROG.: 170.483
 Progr. km: 6400.000
 Dist. prec.: 100.000
 Dist. succ.: 100.000

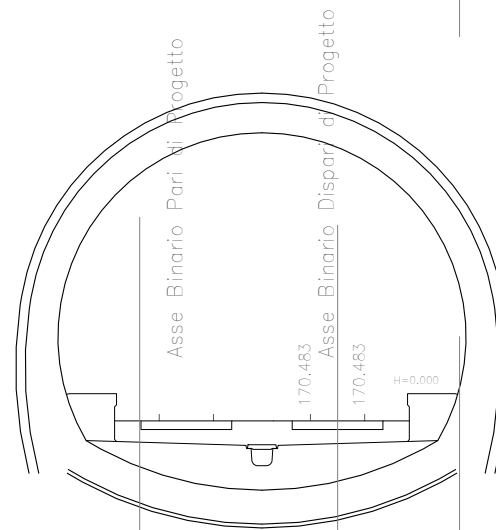

1:200

Qt. rif. 160.000

Quote Progetto	
Quote Terreno	-209.00 -199.33 -195.42 -193.01 -193.13 -192.83 -192.38 -191.99 -191.78 -188.02 -186.01 -185.60
Distanze Parz. Progetto	
Distanze Progetto	
Distanze Terreno	-33.50 -5.24 -0.00 -3.23 15.40 15.49 20.38 20.72 -24.99 -30.75 33.15 33.28

SEZIONE N°: 66
 QT. PROG.: 169.560
 Progr. km: 6500.000
 Dist. prec.: 100.000
 Dist. succ.: 100.000

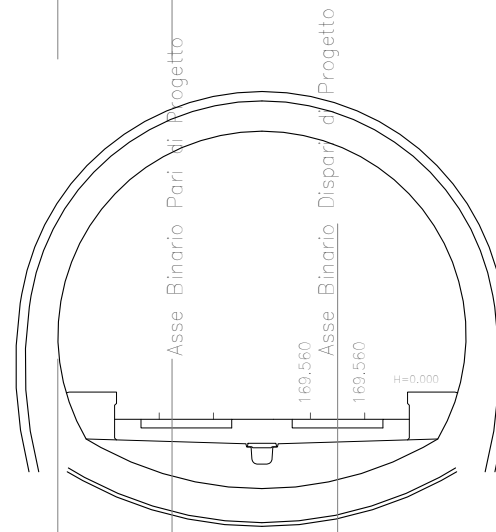

1:200

Qt. rif. 152.000

Quote Progetto								
Quote Terreno	-242.29	-238.61	-233.30	-232.04	-229.98	-225.35		-214.05
Distanze Parz. Progetto								
Distanze Progetto								
Distanze Terreno	-31.39	-22.01	-7.40	-4.38	0.00	9.81		28.76

SEZIONE N°: 67
 QT. PROG.: 168.638
 Progr. km: 6600.000
 Dist. prec.: 100.000
 Dist. succ.: 100.000

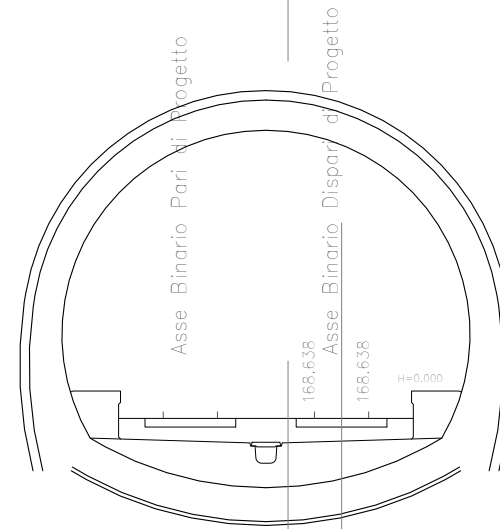

1:200

Qt. rif. 151.000

Quote Progetto							
Quote Terreno		-241,95	-239,54	-236,48	-235,95	-231,09	-225,00
Distanze Parz. Progetto							
Distanze Progetto							
Distanze Terreno		-16,89	-10,42	-1,42	-0,00	-13,23	-28,39

SEZIONE N°: 68
 QT. PROG.: 167.715
 Progr. km: 6700.000
 Dist. prec.: 100.000
 Dist. succ.: 100.000

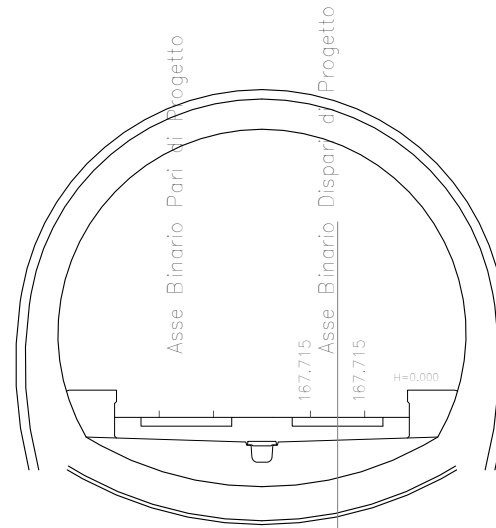

1:200

Qt. rif. 150.000

Quote Progetto							
Quote Terreno	-238.62	-231.82	-227.90	-225.00	-225.00		-220.19
Distanze Parz. Progetto							
Distanze Progetto							
Distanze Terreno	-33.39	-11.24	-0.00	-8.31	-11.76		-26.85

SEZIONE N°: 69
QT. PROG.: 166.793
Progr. km: 6800.000
Dist. prec.: 100.000
Dist. succ.: 100.000

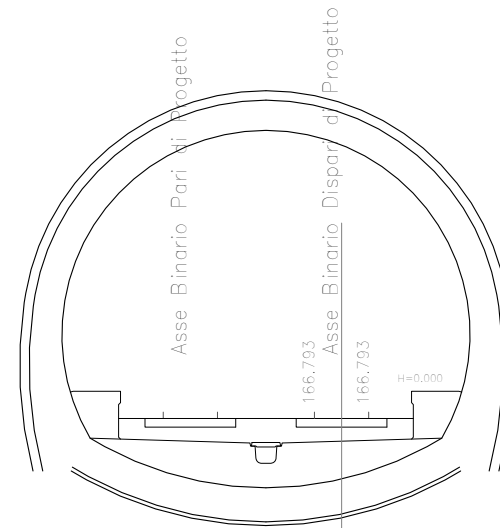

1:200

Qt. rif. 149.000

Quote Progetto			
Quote Terreno	-250.00	-239.54	-229.64
Distanze Parz. Progetto			
Distanze Progetto			
Distanze Terreno	-26.49	-0.00	-26.95

SEZIONE N°: 70
 QT. PROG.: 165.870
 Progr. km: 6900.000
 Dist. prec.: 100.000
 Dist. succ.: 100.000

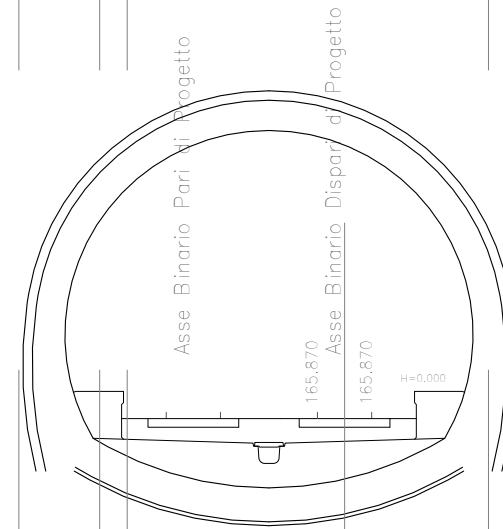

1:200

Qt. rif. 148.000

Quote Progetto										
Quote Terreno		-226.38	-225.00	-224.18	-223.69	-221.35	-219.80	-216.47	-215.10	-208.50
Distanze Parz. Progetto										
Distanze Progetto										
Distanze Terreno		-10.87	-8.62	-6.48	-5.75	-0.00	-3.81	-6.99	-9.64	-24.08

SEZIONE N°: 71
 QT. PROG.: 164.948
 Progr. km: 7000.000
 Dist. prec.: 100.000
 Dist. succ.: 100.000

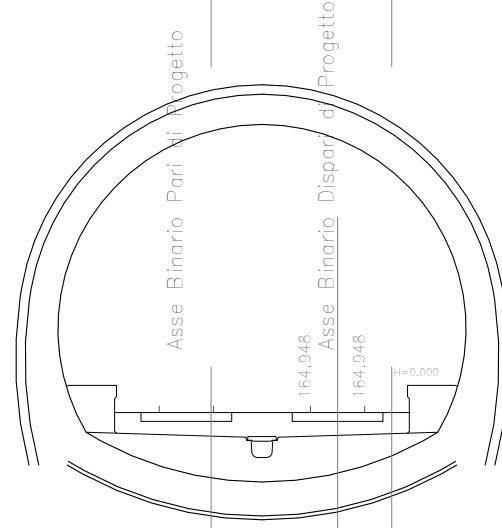

1:200

Qt. rif. 147.000

Quote Progetto																										
Quote Terreno	-226.64	-225.05	-223.78	-223.00	-222.18	-220.37		-216.15	-215.13		-210.35	-208.36	-207.51		-205.15		-201.00	-199.04		-197.49	-196.68	-194.99	-194.39	-194.15	-193.96	
Distanze Parz. Progetto																										
Distanze Progetto																										
Distanze Terreno	-31.53	-28.71	-27.20	-25.30	-23.82	-20.04		-12.62	-9.66		-3.35	0.00	1.43		-5.09		-11.44	-15.59		-19.76	-23.70	-26.40	-28.29	-32.31	-33.06	

SEZIONE N° 72
 QT. PROG.: 164.025
 Progr. km: 7100.000
 Dist. prec.: 100.000
 Dist. succ.: 100.000

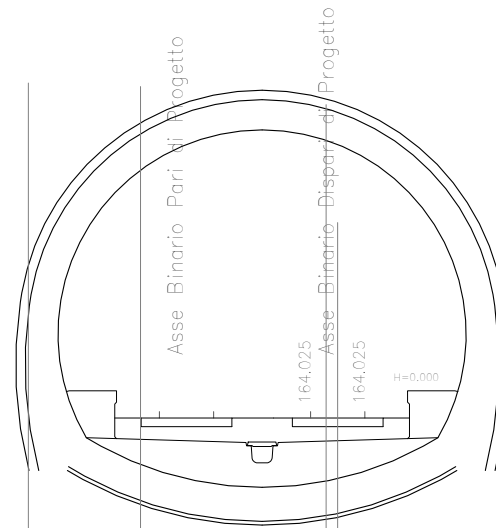

1:200

Qt. rif. 154.000

Quote Progetto																						
Quote Terreno	-207.20	-206.26	-206.11	-204.33	-204.20	-202.62	-199.76	-199.43	-199.13	-199.37	-199.19	198.23 196.16	196.75 196.74	-196.50	-195.40	-194.43	-194.21	-192.00	-191.00	-189.12	-188.26	-187.90 -186.52
Distanze Parz. Progetto																						
Distanze Progetto																						
Distanze Terreno	-32.94	-29.84	-28.46	-24.29 -23.47		-18.41	-14.11	-12.95	-10.29	-8.19	-5.22	-0.30 0.00	6.02 6.10	-9.44	-15.76	-18.16	-19.24	-24.16	-26.03	-28.20	-29.45	-32.31 -32.76

SEZIONE N°: 73
 QT. PROG.: 163.102
 Progr. km: 7200.000
 Dist. prec.: 100.000
 Dist. succ.: 110.384

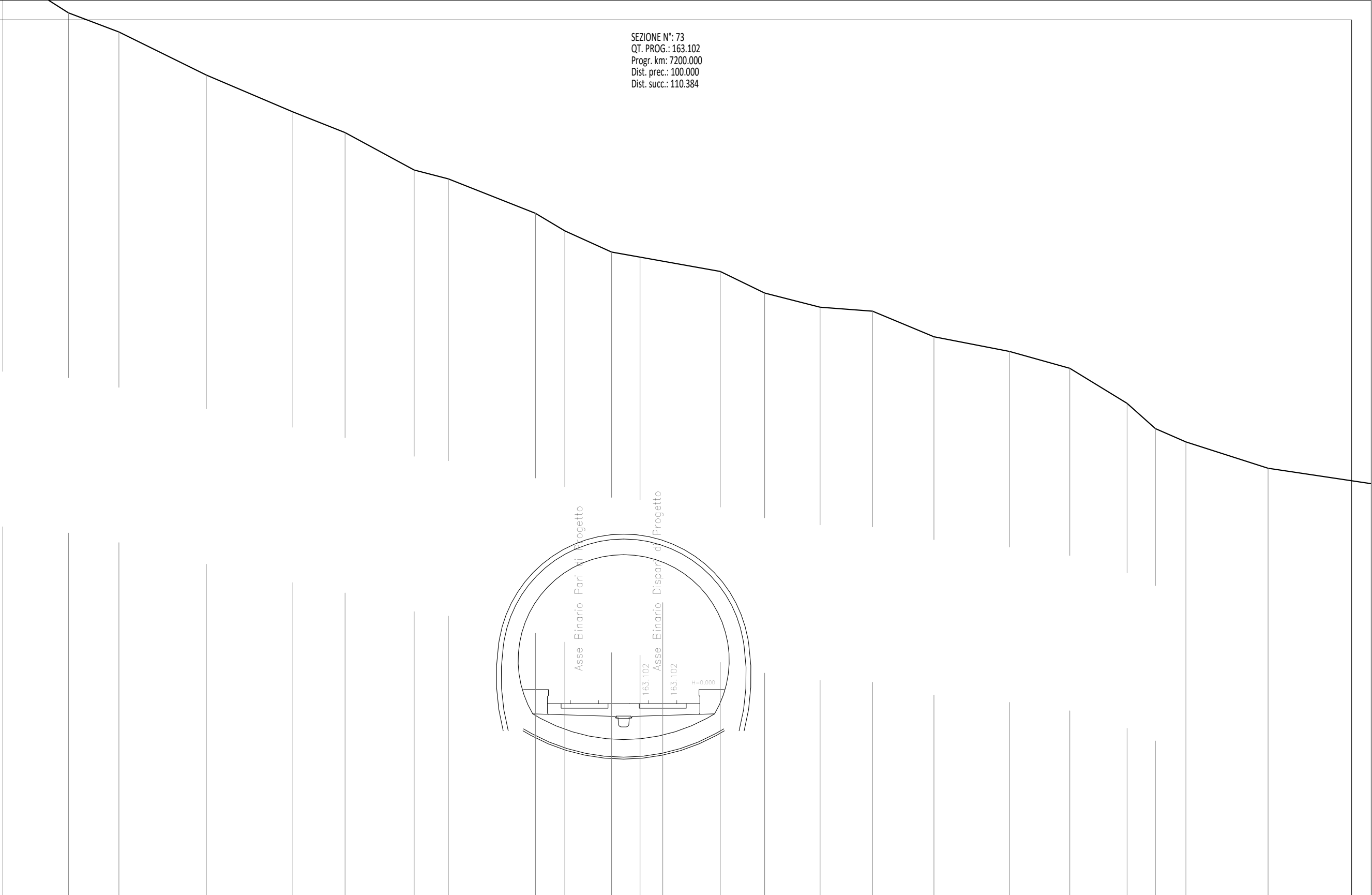

1:200

Qt. rif. 153.000

Quote Progetto																								
Quote Terreno		-196.26	-197.28	-195.08	-193.19	-192.13	-190.22	-189.76	-188.01	-187.11	-186.02	-185.76	-185.56	-185.03	-183.93	-183.21	-183.00	-181.69	-180.94	-180.08	-178.29	-177.00	-176.32	-174.97
Distanze Parz. Progetto																								
Distanze Progetto																								
Distanze Terreno		-30.41	-27.83	-23.36	-18.93	-16.26	-12.72	-10.97	-6.52	-5.01	-2.62	-1.16	0.00	-2.94	-5.21	-8.05	-10.73	-13.88	-17.74	-20.83	-23.76	-25.21	-26.77	-30.97

SCAVI E BONIFICHE	
SCAVO DI SBANCAMENTO	13.310 m ²
RILEVATI	
RILEVATO FERROVIARIO	6.829 m ²
PAVIMENTAZIONI	
SUPERCOMPATTATO	2.340 m ²

SEZIONE N°: 76
 QT. PROG.: 160.335
 Progr. km: 7500.000
 Dist. prec.: 100.000
 Dist. succ.: 100.000

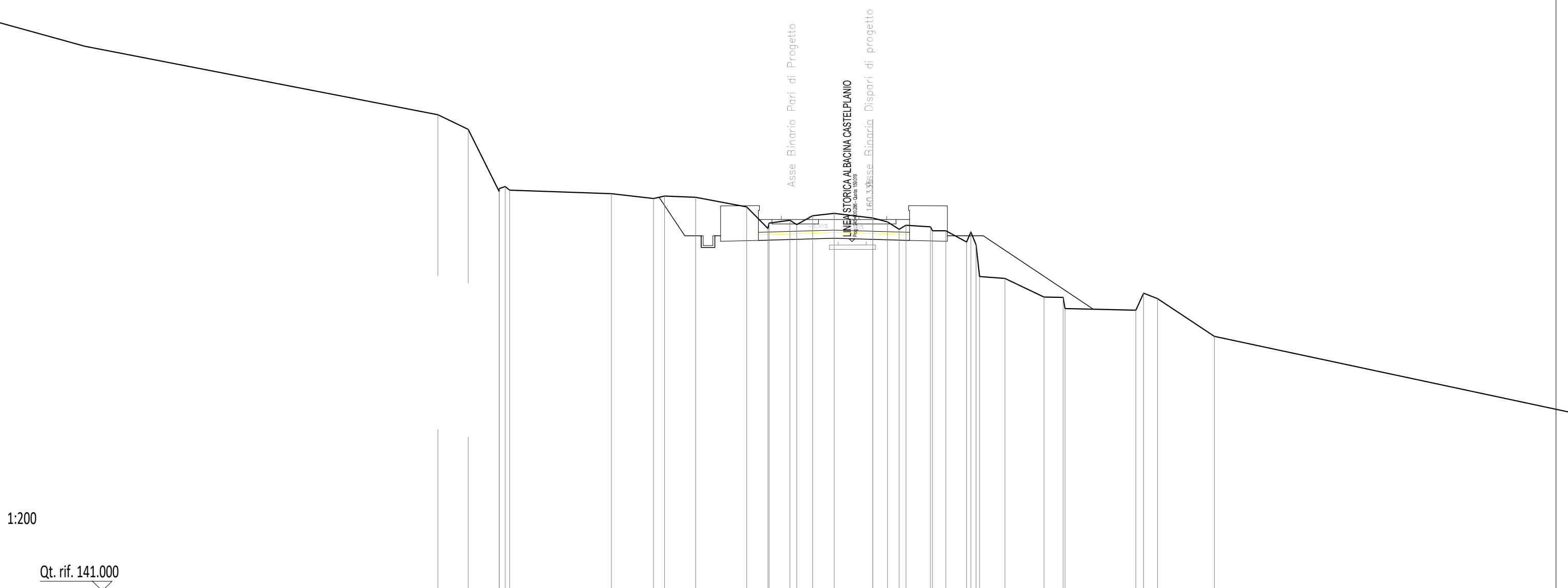

Qt. rif. 141.000

Quote Progetto					161.31	159.32	159.32	159.32	159.08	159.20	159.14	159.08	159.32	159.32		155.54																	
Quote Terreno	-165.57	-164.81	-161.61	-161.68		161.50	161.25	161.37	161.31	160.82	159.70	159.68	160.13	159.90	160.36	160.48	160.24	160.04	159.66	159.87	159.79	159.58	159.00	157.22	159.32	157.12	156.16	156.14	155.57	155.48	156.36	156.08	154.13
Distanze Parz. Progetto							1.32	0.85	0.70		6.15					2.00		4.15			1.55		5.68										
Distanze Progetto					-11.02		-9.70	-8.85	-8.15	-7.85	-5.90					-2.00		-1.90		-3.85	-4.15	-5.70		-11.38									
Distanze Terreno	-22.43	-20.87	-19.26	-18.74		-13.46	-11.31	-10.74	-9.14	-6.51	-5.41	-5.35	-4.27	-3.92	-3.10	-1.99		-0.76	-1.36	-1.71	-2.98	-3.77	-4.84	-5.51	-6.82	-8.83	-9.82	-9.92		-13.57	-13.97	-14.69	

SCAVI E BONIFICHE	
SOSTITUZIONE TERRENI	8,628 m ²
SCAVO DI SBANCAMENTO	10,892 m ²
RILEVATI	
RILEVATO FERROVIARIO	6,387 m ²
TERRENO VEGETALE	5,392 m
PAVIMENTAZIONI	
SUPERCOMPATTATO	3,866 m ²
SUBBALLAST	1,515 m ²

SEZIONE N°: 77
 QT. PROG.: 159.412
 Progr. km: 7600.000
 Dist. prec.: 100.000
 Dist. succ.: 100.000

1:200

Qt. rif. 137.000

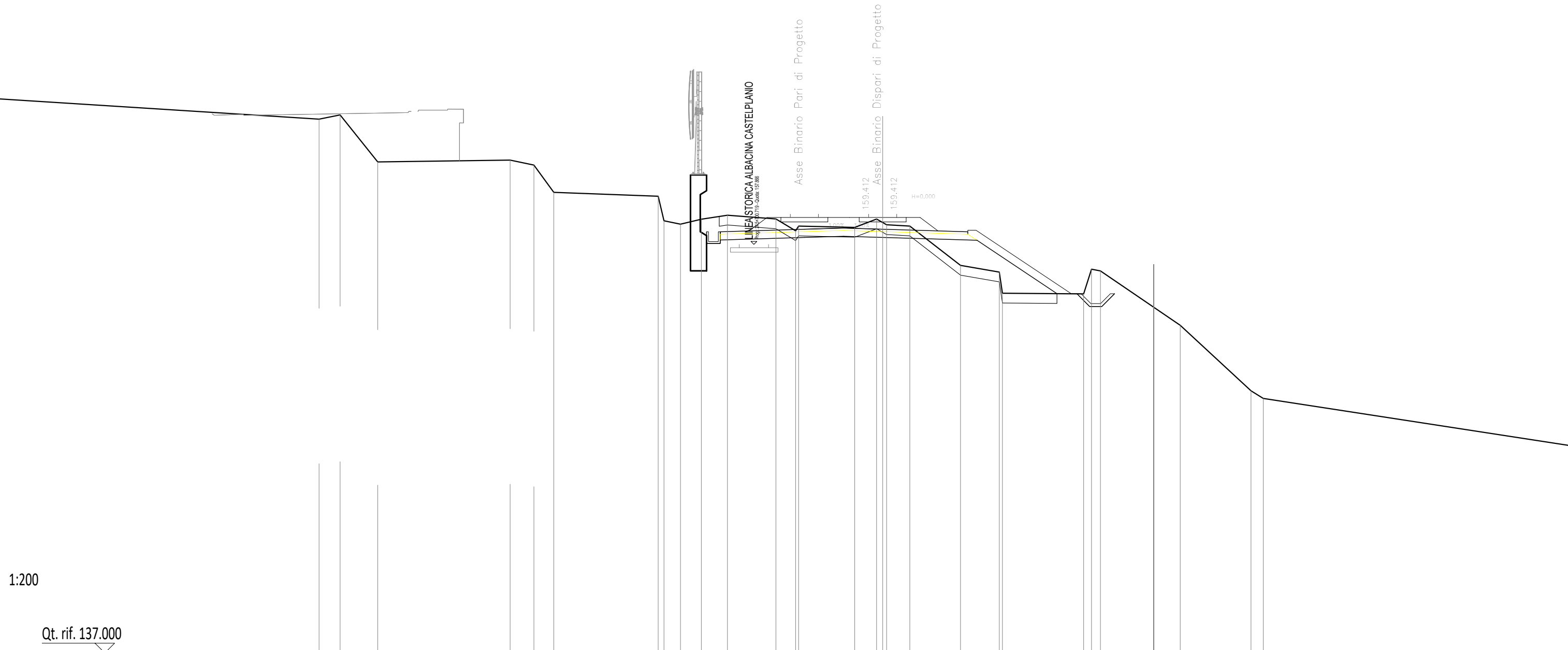

Quote Progetto															157.91	157.91	158.22	158.28	158.22	158.09	158.08	155.35	155.34	154.69	154.69	155.34					150.39	150.00																
Quote Terreno								164.26	164.48	162.08				162.17	161.92	160.52		160.33	159.07	158.90	159.15	159.36		159.17	158.56	158.80	158.73	159.16	158.67	158.80		156.79	158.08	156.45	155.37	155.35	155.34	154.69	154.69	155.34		153.73		150.39	150.00			
Distanze Parz. Progetto																	7.00		6.35		5.15	1.92																										
Distanze Progetto																							-9.00	-8.30																								
Distanze Terreno								-28.80	-27.72	-25.80				-19.04	-17.82	-16.81		-11.47	-11.18	-10.33	-9.27	-7.93		-5.46	-4.45	-4.30	-1.43	-0.31	-0.20	-1.39		-3.98	-4.35	-4.82	5.96	-6.12	-8.91	-9.92	-10.57	-11.20	-11.85		-15.20		-18.82	-19.45		

SCAVI E BONIFICHE	
SOSTITUZIONE TERRENI	6.350 m ²
SCAVO DI SBANCAMENTO	19.231 m ²
PAVIMENTAZIONI	
SUPERCOMPATTATO	3.795 m ²
SUBBALLAST	1.515 m ²

SEZIONE N°: 79
 QT. PROG.: 157.589
 Progr. km: 7800.000
 Dist. prec.: 100.000
 Dist. succ.: 100.000

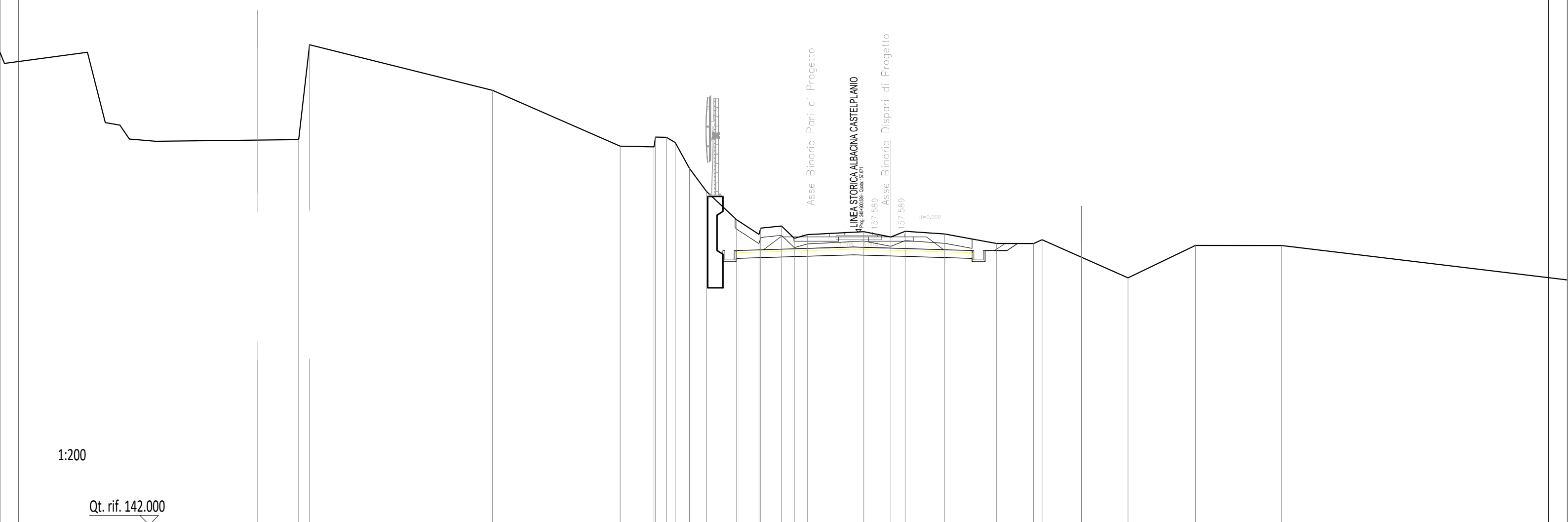

1:200

Qt. rif. 142.000

Quote Progetto						156.09	156.09			156.40	156.46	156.40		156.09	156.09	156.69	157.06											
Quote Terreno	162.63	167.71	165.27	162.28	162.24	162.75	162.47	161.09	159.85	156.34	157.55	157.89	158.00	157.34	157.54	157.70	157.41	157.72	157.57	157.07	156.69	157.06	157.27		155.23	156.96		156.96
Distanze Parz. Progetto												14.05					0.30	0.57	0.56									
Distanze Progetto								-9.00	-8.30								-4.35	-5.05	-5.55	-6.12	-6.79							
Distanze Terreno	-31.74	-31.15	-21.35	-14.51	-12.70	-12.03	-11.56	-10.79	-9.88	-8.27	-7.07	-6.98	-5.86	-5.18	-4.48	-1.45	0.00	-0.77		-2.89	-5.65	-7.65	-8.10		-12.71	-16.32		-20.94

SCAVI E BONIFICHE	
SCAVO DI SBANCAMENTO	18,581 m ²
RILEVATI	
TERRENO VEGETALE	0,630 m
PAVIMENTAZIONI	
SUPERCOMPATTATO	3,795 m ²
SUBBALLAST	1,515 m ²

SEZIONE N°: 80
 QT. PROG.: 157.110
 Progr. km: 7900.000
 Dist. prec.: 100.000
 Dist. succ.: 100.000

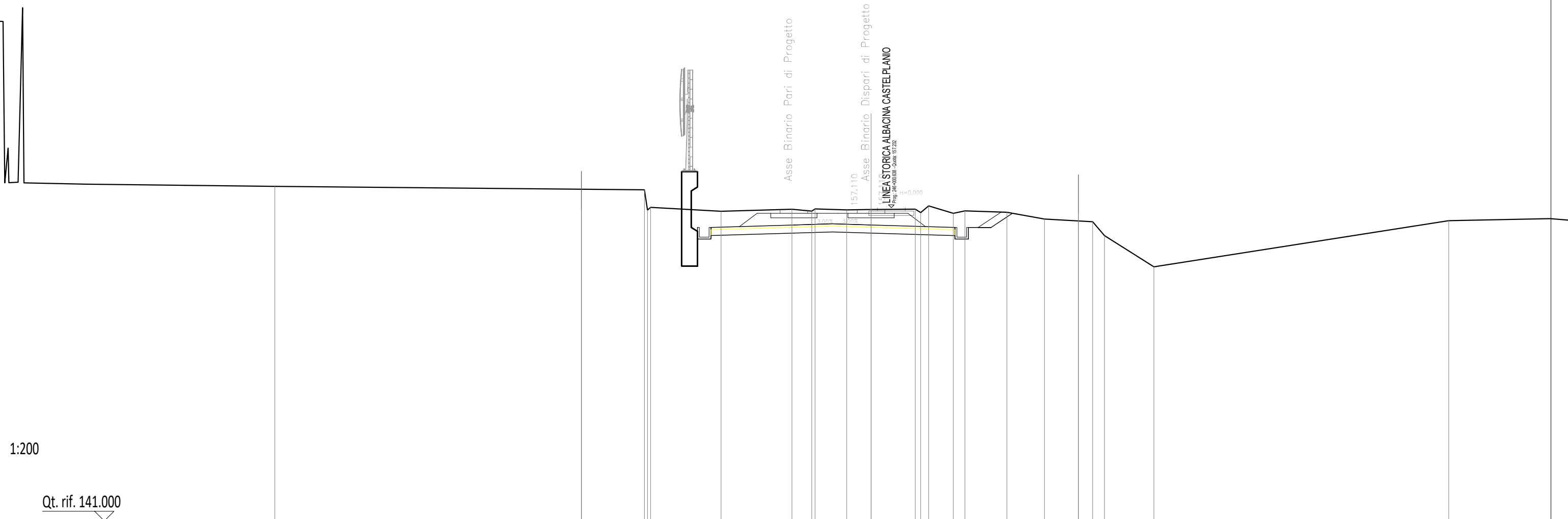

1:200

Qt. rif. 141.000

Quote Progetto				155.61	155.61	155.92	155.98	155.92	155.61	155.61	156.21	156.56	156.94							
Quote Terreno	156.34	158.16	157.25	157.05	157.15	157.06	157.17	157.12	157.14	157.16	157.33	156.94	157.07	156.21	156.99	156.65	156.51	155.78	154.17	156.56
Distanze Parz. Progetto					7.00				6.35		0.70	0.30	1.20	0.58						
Distanze Progetto					-9.00	-8.30	-4.00	-2.00	-0.00		-4.35	-5.05	-5.55	-6.22	-6.75	-7.33				
Distanze Terreno	-30.91	-11.75	-11.43	-7.78	-4.10	-3.07	-2.90	-1.26	-0.00	-2.29	-2.99	-4.27	-4.87	-7.04	-8.99	-11.49	-12.10	-14.67	-29.95	

SCAVI E BONIFICHE	
SCAVO DI SBANCAMENTO	7.283 m ²
PAVIMENTAZIONI	
SUPERCOMPATTATO	2.100 m ²
SUBBALLAST	0.840 m ²

SEZIONE N°: 82
 QT. PROG.: 156.751
 Progr. km: 8100.000
 Dist. prec.: 100.000
 Dist. succ.: 100.000

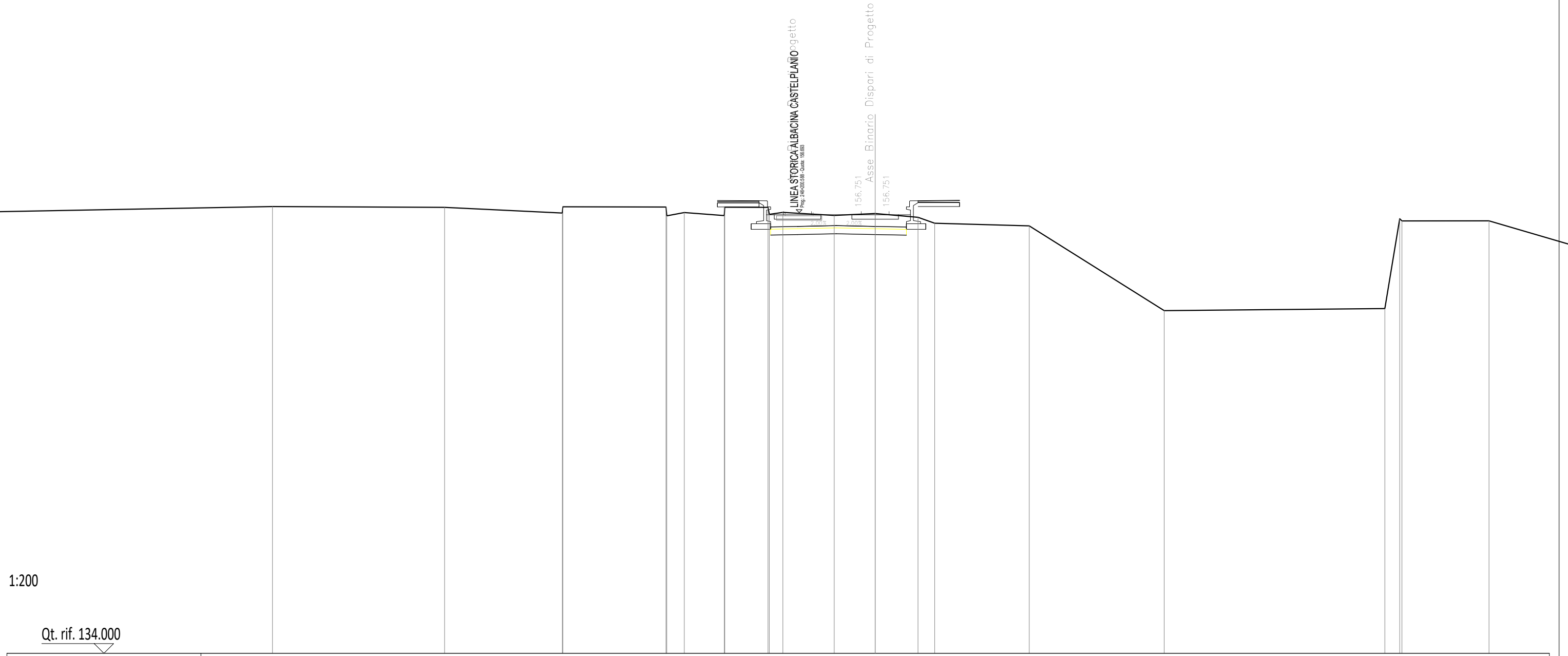

1:200

Qt. rif. 134.000

Quote Progetto								155.53	155.56	155.60	155.57	155.56	155.53							
Quote Terreno	-157.00	-156.96	156.57 156.39	-156.98	-156.69	156.54 156.97	-156.96	-156.70	-156.54	-155.54	-156.64	-156.45	-156.14	-156.01	-151.64	-151.75	156.38 156.26	-156.27		
Distanze Parz. Progetto										1.28										
Distanze Progetto							-5.39	-4.00	-2.00	-0.72	-0.00	-1.61								
Distanze Terreno	-31.06	-22.19	-16.12 -16.10	-10.78	-9.84	-7.78 -7.75	-5.52	-4.76	-2.11	-0.00	-2.21	-3.07	-7.94	-14.90	-26.27	27.03 27.15	-31.64			

SCAVI E BONIFICHE	
SCAVO DI SBANCAMENTO	7.495 m ²
PAVIMENTAZIONI	
SUPERCOMPATTATO	2.100 m ²
SUBBALLAST	0.840 m ²

SEZIONE N°: 83
 QT. PROG.: 156.653
 Progr. km: 8200.000
 Dist. prec.: 100.000
 Dist. succ.: 100.000

1:200

Qt. rif. 135.000

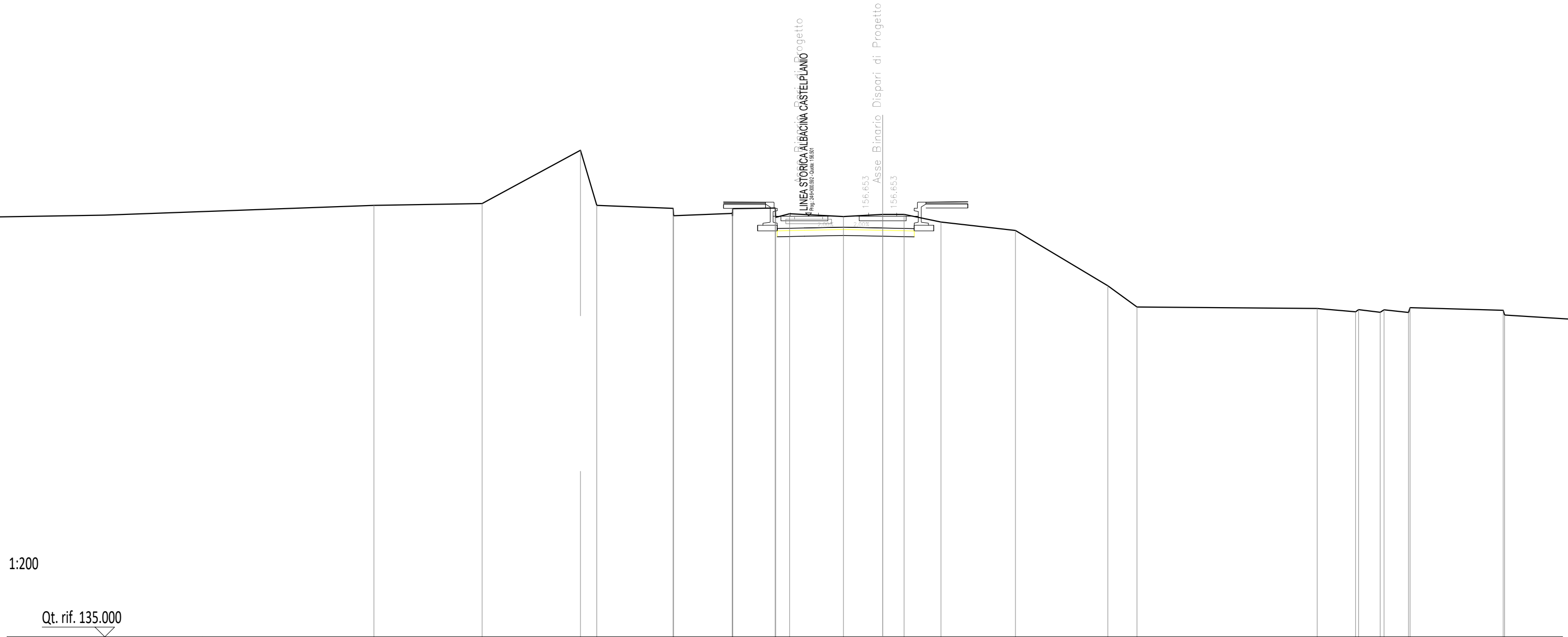

Quote Progetto																																							
Quote Terreno	-157.04		-157.13		-159.85	-157.04	156.89	156.51	156.63	156.87	-156.90	-155.43	-155.46	155.50	155.47	155.58	155.46	-156.58	156.58	-155.43	-156.19		-155.76		-152.93	-151.85			151.77	151.50	151.71	151.58	151.70	151.57	151.81			151.68	151.44
Distanze Parz. Progetto														1.28																									
Distanze Progetto																																							
Distanze Terreno	-26.00		-20.47		-15.44	-14.61	-10.71	-10.66	-7.69	-7.66	-5.49	-4.76	-4.00	-2.00	-2.00	-0.72	-0.00	1.10	1.61	2.98		6.78		11.51	13.00			22.20	24.16	24.32	25.42	25.62	26.87	26.95			31.71	31.78	

SCAVI E BONIFICHE	
SOSTITUZIONE TERRENI	9,784 m ²
SCAVO DI SBANCAMENTO	4,522 m ²
RILEVATI	
RILEVATO FERROVIARIO	12,655 m ²
TERRENO VEGETALE	6,228 m ²
PAVIMENTAZIONI	
SUPERCOMPATTATO	3,779 m ²
SUBBALLAST	1,515 m ²

SEZIONE N°: 85
 QT. PROG.: 156.379
 Progr. km: 8400.000
 Dist. prec.: 100.000
 Dist. succ.: 100.000

1:200

Qt. rif. 135.000

Quote Progetto							154.88	154.88	155.19	155.25	155.19		155.06				150.90	150.90	150.90	150.25	150.90												
Quote Terreno		154.87					156.04	155.23				154.93	154.99	155.08	154.31	152.38	152.35	152.35	151.95					150.90	150.90	150.76	150.25	150.90				157.32	157.87
Distanze Parz. Progetto													8.35				0.48		6.00		1.92												
Distanze Progetto							-9.00	-8.30	-4.00	-2.00	-0.00			-4.30		-6.35	-6.83				-12.01	-12.83	-13.48	-14.10	-14.75								
Distanze Terreno		-27.56					-5.76	-5.55								-5.41	-5.97	-6.32		-8.71					-12.07	-12.54	-13.15			-22.64		-29.85	-31.04

SCAVI E BONIFICHE	
SOSTITUZIONE TERRENI	10.772 m ²
SCAVO DI SBANCAMENTO	12.432 m ²
SCAVO PER FOSSI DI GUARDIA CANALETTE E FOSSI DISPERDENTI	0.013 m ²
RILEVATI	
RILEVATO FERROVIARIO	15.247 m ²
TERRENO VEGETALE	8.458 m ²
PAVIMENTAZIONI	
SUPERCOMPATTATO	3.777 m ²
SUBBALLAST	1.518 m ²

SEZIONE N°: 86
 QT. PROG.: 155.637
 Progr. km: 8500.000
 Dist. prec.: 100.000
 Dist. succ.: 100.000

1:200

Qt. rif. 135.000

Quote Progetto					154.13	154.13		154.45		154.51		154.45		154.32		153.93	153.61				148.92	149.03	148.36	148.36	149.43				
Quote Terreno	159.35	155.17	155.04		155.67	154.13		154.45		155.59	155.65	154.98	155.07	155.01	154.75		148.97				148.71	149.03	148.36	148.36	149.43		146.80		147.93
Distanze Parz. Progetto										15.35						0.48	7.69				2.32								
Distanze Progetto					-9.00	-8.30		-4.00		-2.00		-0.00			-4.30	-6.35	-6.83				13.86	14.52	15.17	15.79	16.84				
Distanze Terreno	-32.18	-28.93	-26.21		-9.25					-2.71	-2.01	-1.33	-1.26	-0.00	-1.43						-10.40	-13.23	-15.98				-20.17		-23.47

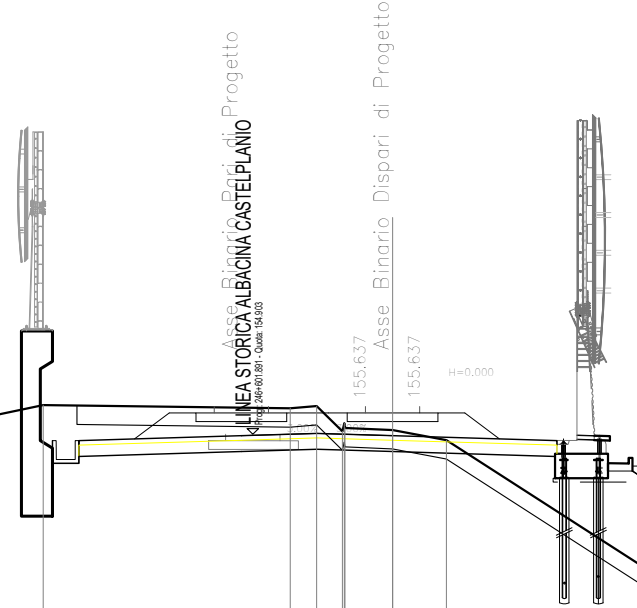

SCAVI E BONIFICHE	
SCAVO DI SBANCAMENTO	13.190 m ²
PAVIMENTAZIONI	
SUPERCOMPATTATO	3.795 m ²
SUBBALLAST	1.515 m ²

SEZIONE N°: 88
 QT. PROG.: 154.080
 Progr. km: 8700.000
 Dist. prec.: 100.000
 Dist. succ.: 100.000

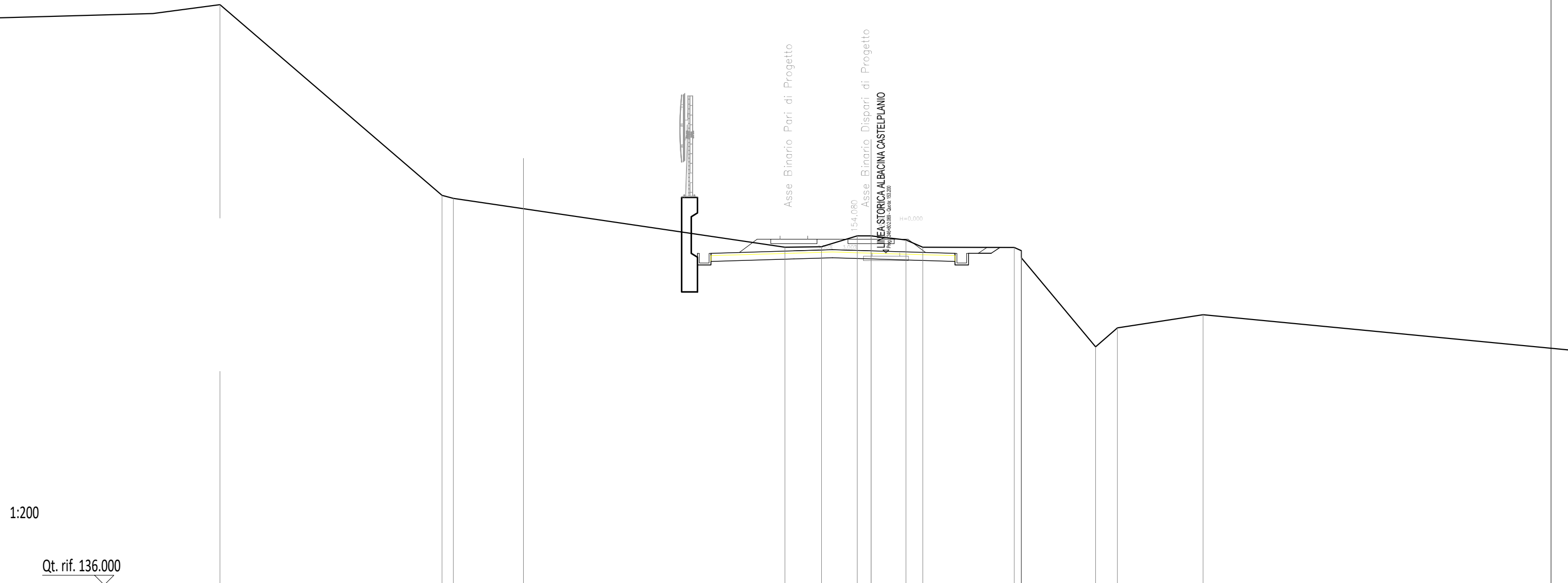

Quote Progetto				152.58	152.58	152.89	152.95	152.89		152.58	152.58	153.18	153.48					
Quote Terreno	166.07	156.18	156.03			153.50	153.52	154.08	154.08	153.87	153.49		153.48	152.95		146.33	149.32	150.00
Distanze Parz. Progetto						7.00			6.35			0.70	0.50	0.46				
Distanze Progetto				-9.00	-8.30	-4.00	-2.00	-0.00		-4.35	-5.05	-5.55	-6.22	-6.68				
Distanze Terreno	-33.75	-22.24	-21.65			-4.46	-2.57	-0.72	-0.00	-1.81	-2.68		-7.42	-7.79		-11.64	-12.77	-17.21

SCAVI E BONIFICHE	
SCAVO DI SBANCAMENTO	10.720 m³
SCAVO PER FOSSI DI GUARDIA CANALETTE E FOSSI DISPERDENTI	0.901 m³
RILEVATI	
RILEVATO FERROVIARIO	0.043 m³
TERRENO VEGETALE	1.627 m
PAVIMENTAZIONI	
SUPERCOMPATTATO	3.810 m³
SUBBALLAST	1.524 m³

SEZIONE N°: 89
 QT. PROG.: 153.302
 Progr. km: 8800.000
 Dist. prec.: 100.000
 Dist. succ.: 89.892

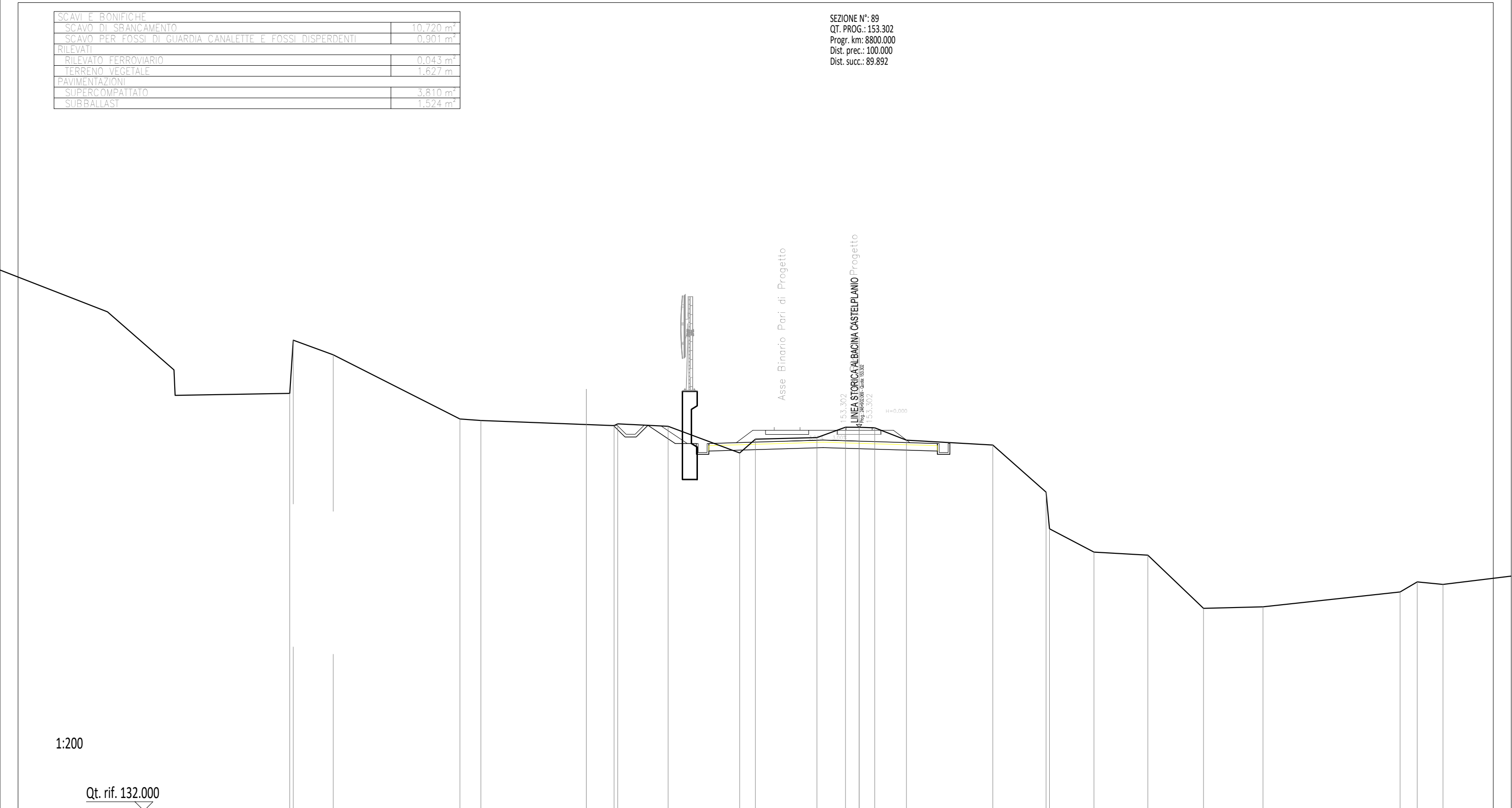

1:200

Qt. rif. 132.000

Quote Progetto								153.41	152.93	152.40	152.40	151.80	151.80				152.11	152.17	153.30	153.30	153.27		152.58		151.80	151.80							
Quote Terreno	155.18	156.14	157.33	153.76	153.68	153.39	153.49	153.36	152.40	152.40	152.40	151.80	151.80	151.88	152.64	152.11	152.73	152.17	153.30	153.30	153.27	152.58	152.32	149.70	147.66	146.37	146.20	143.24	143.33	144.15	144.71	144.57	
Distanze Parz. Progetto								0.72	1.47	0.50	0.70			Ø 35					Ø 35		0.70												
Distanze Progetto								-11.74	-11.02	-10.22	-9.55	-9.05	-8.35			-4.00	-2.00		-0.00			-4.35	-5.05										
Distanze Terreno	-31.65	-31.45	-29.23	-22.19	-21.02	-13.62	-13.41	-10.62						-6.64	-5.77	-4.00	-2.34	-0.75	0.00	0.87		-2.63		10.39	10.58	-13.06	-16.05	-19.14	-22.45	-30.07	-31.02	-32.45	

SCAVI E BONIFICHE	
SCAVO DI SBANCAMENTO	8.821 m ²
PAVIMENTAZIONI	
SUPERCOMPATTATO	2.520 m ²
SUBBALLAST	1.007 m ²

SEZIONE N°: 90
 QT. PROG.: 152.602
 Progr. km: 8889.892
 Dist. prec.: 89.892



Quote Progetto																														
Quote Terreno		153.83	160.08		152.80	152.31	152.28		152.15	152.30	151.88	151.60	151.13	151.13	152.05	152.12	152.43	151.37	151.43	151.37	151.13	151.13	151.73	151.73	151.76	151.64	151.38			148.55
Distanze Parz. Progetto																			6.20			0.70	0.50	0.49						
Distanze Progetto																														
Distanze Terreno		-28.01	-26.45		-18.11	-16.75	-16.61		-9.39	-7.38	-7.35	-5.01	-4.90	-3.96	-4.20	-2.60	-1.72	-0.00	-0.00	-1.71	-2.35	-4.52	-4.90	-5.40	-6.07	-6.13	-7.00	-7.36		-23.79