

WBS	da pk	a pk	Sviluppo (m)	Lato	Altezza da p.f. (m)
BA02b	7+410	7+528	118	SX - BP	8.50
BA02a	7+528	8+010	482	SX - BP	5.50
BA03a	8+259	8+331	72	SX - BP	5.50
BA03b	8+331	8+463	132	SX - BP	7.50
BA03c	8+463	8+727	264	SX - BP	7.00
BA03d	8+727	8+825	98	SX - BP	5.50
BA04a	8+266	8+401	135	DX - BD	5.50
BA04b	8+401	8+470	69	DX - BD	7.50
BA04c	8+470	8+526	56	DX - BD	5.50

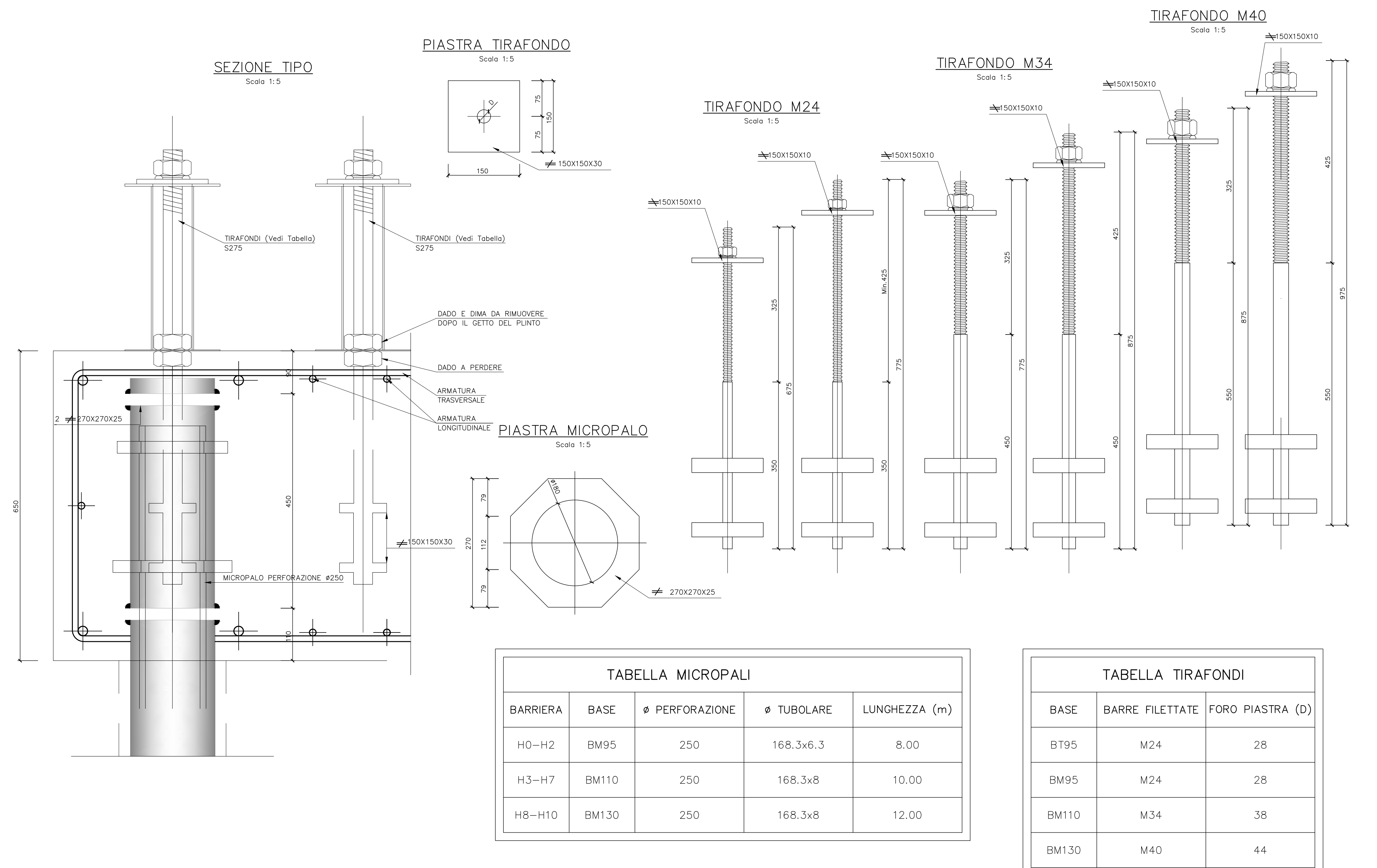
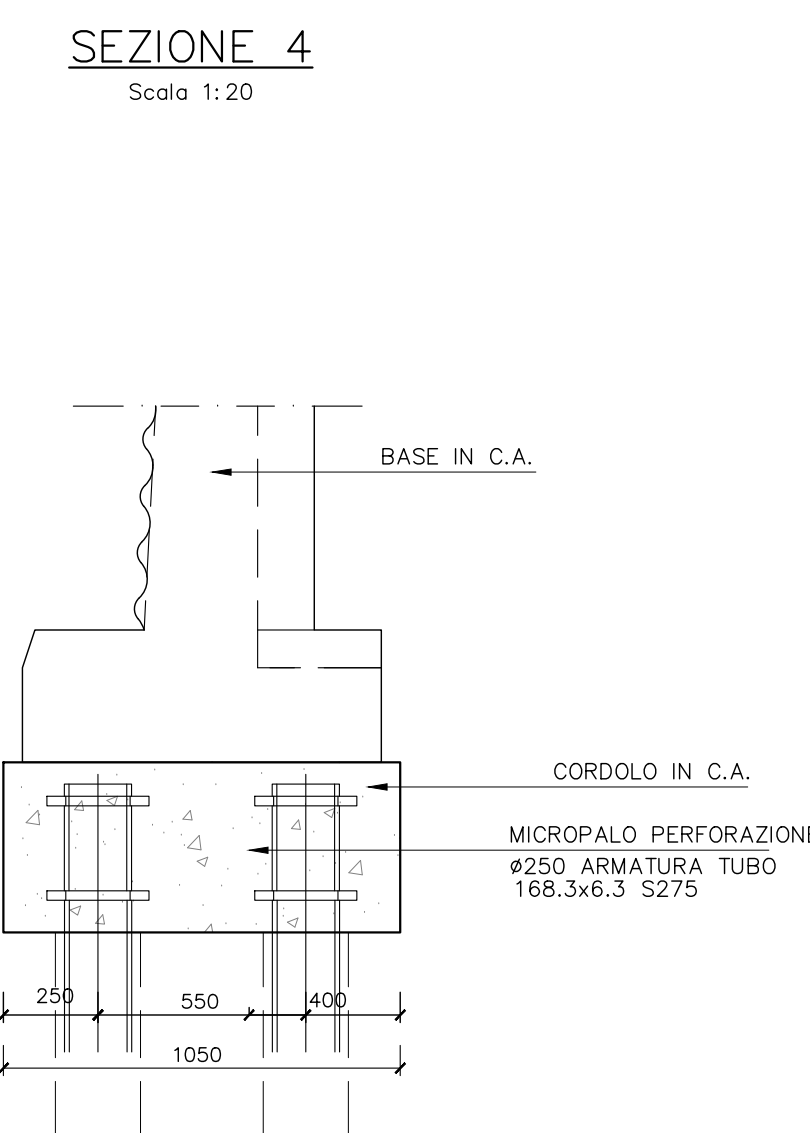
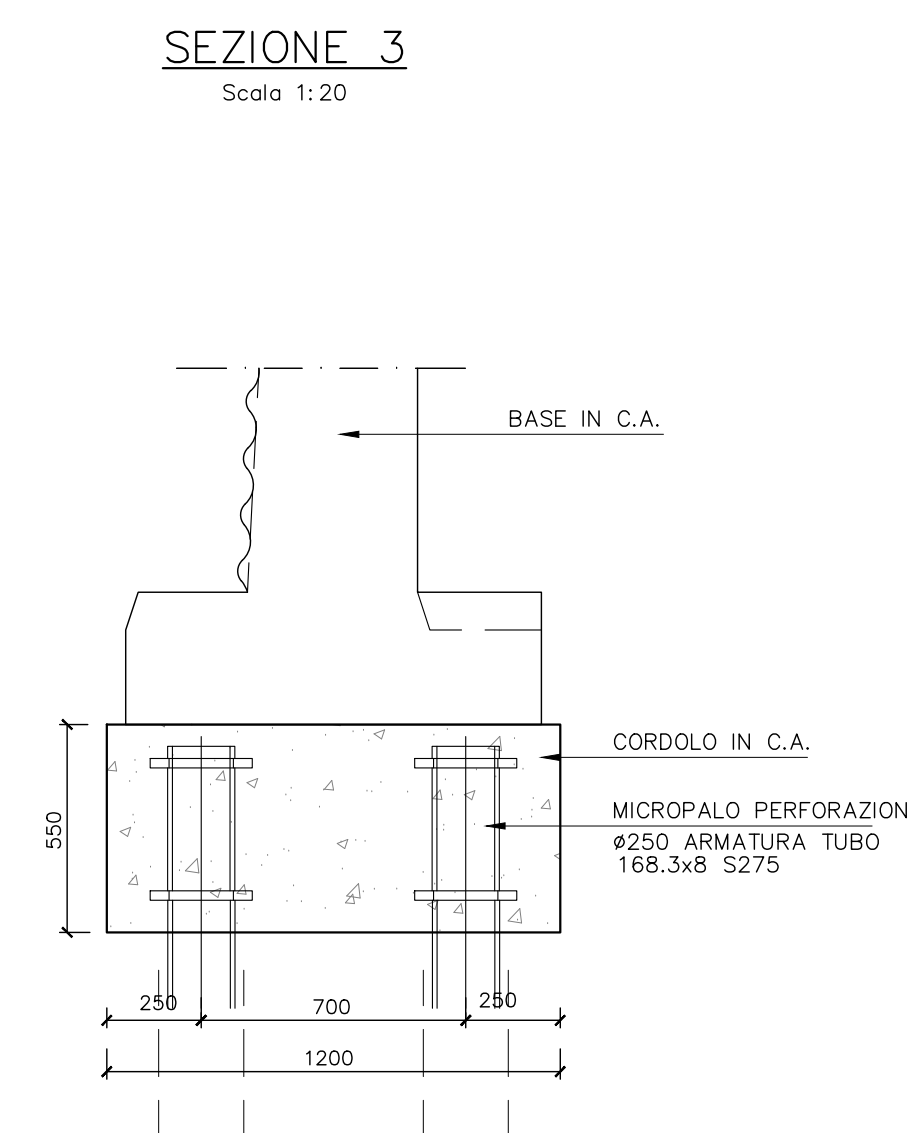
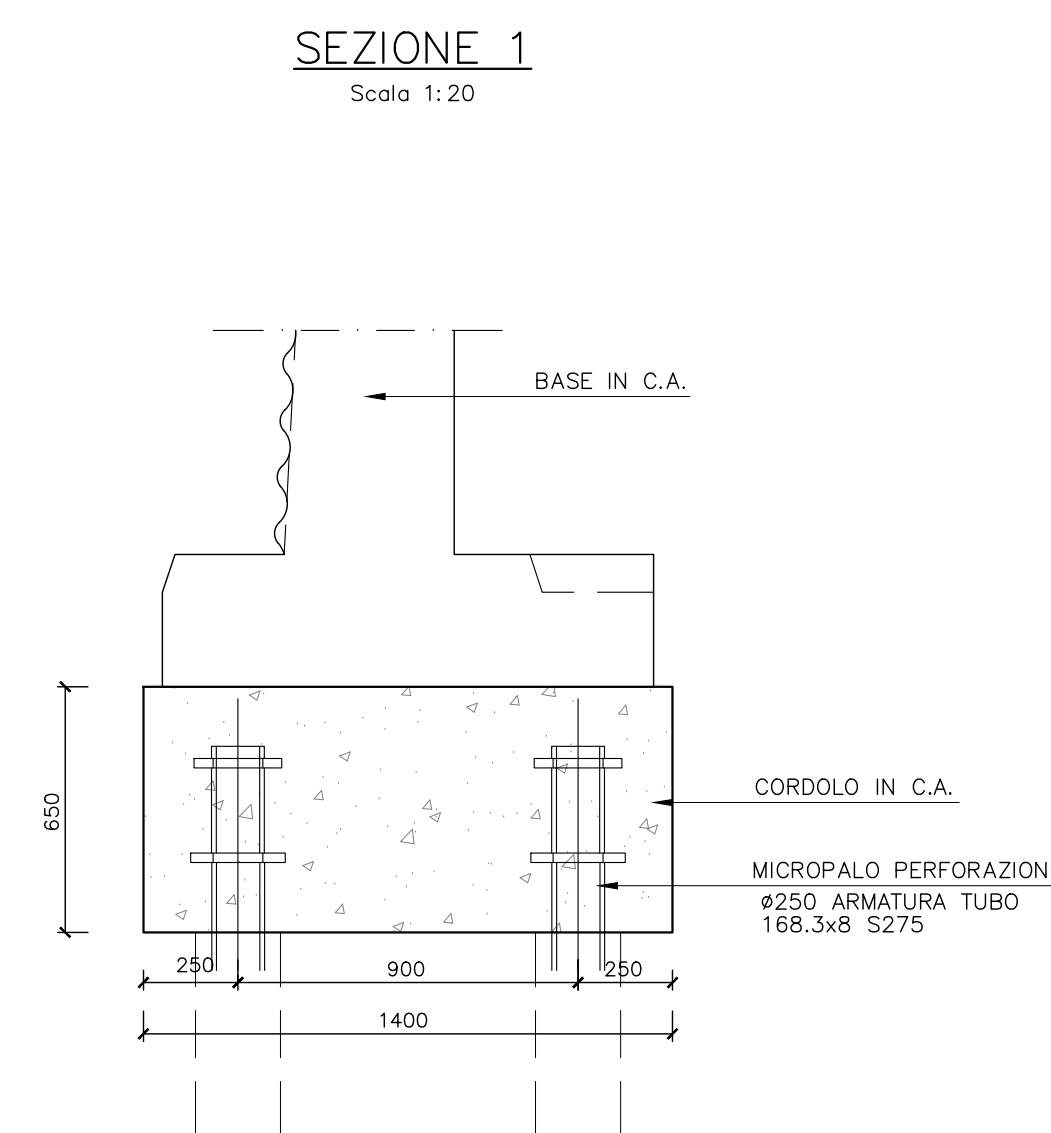
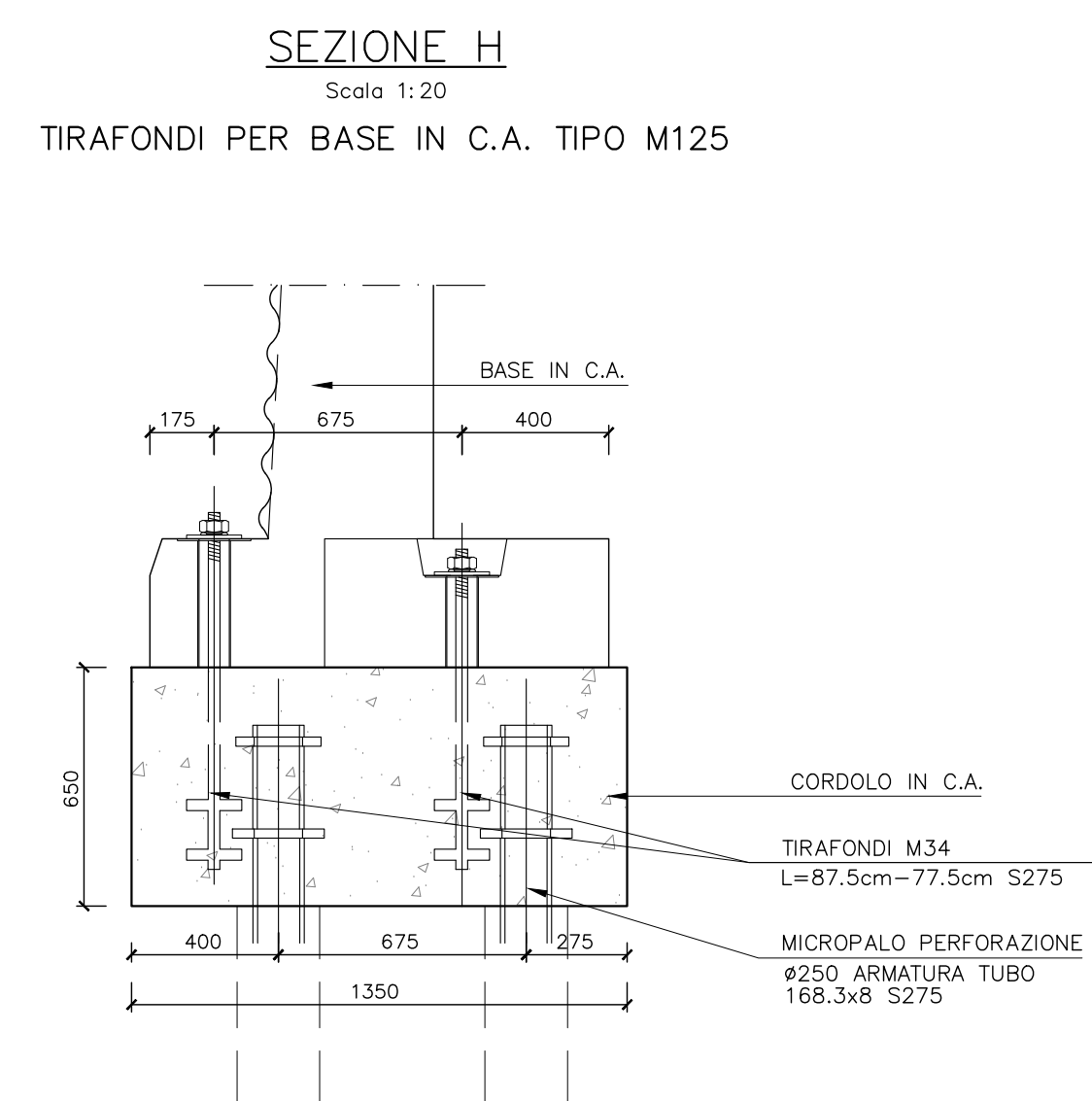
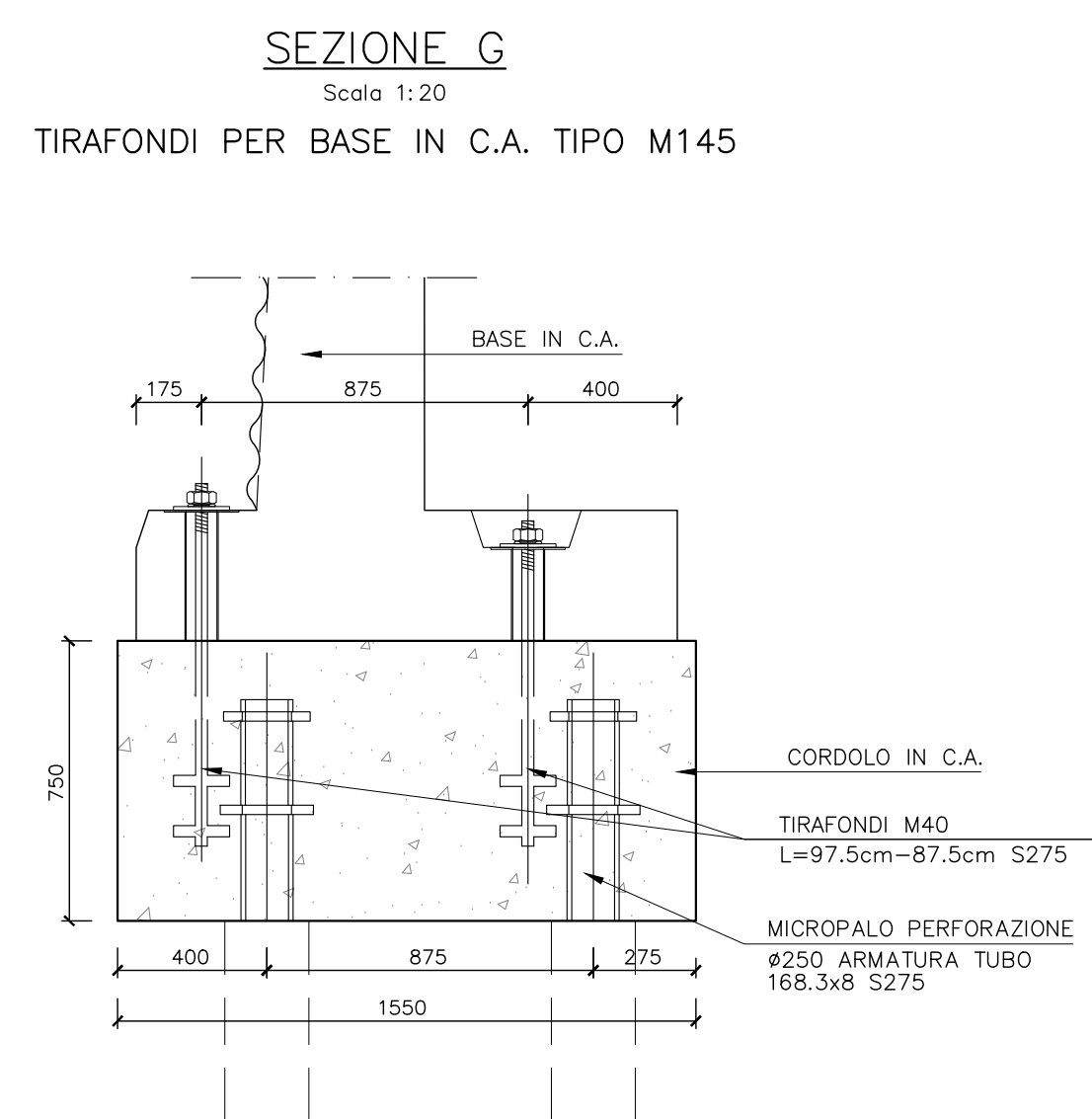
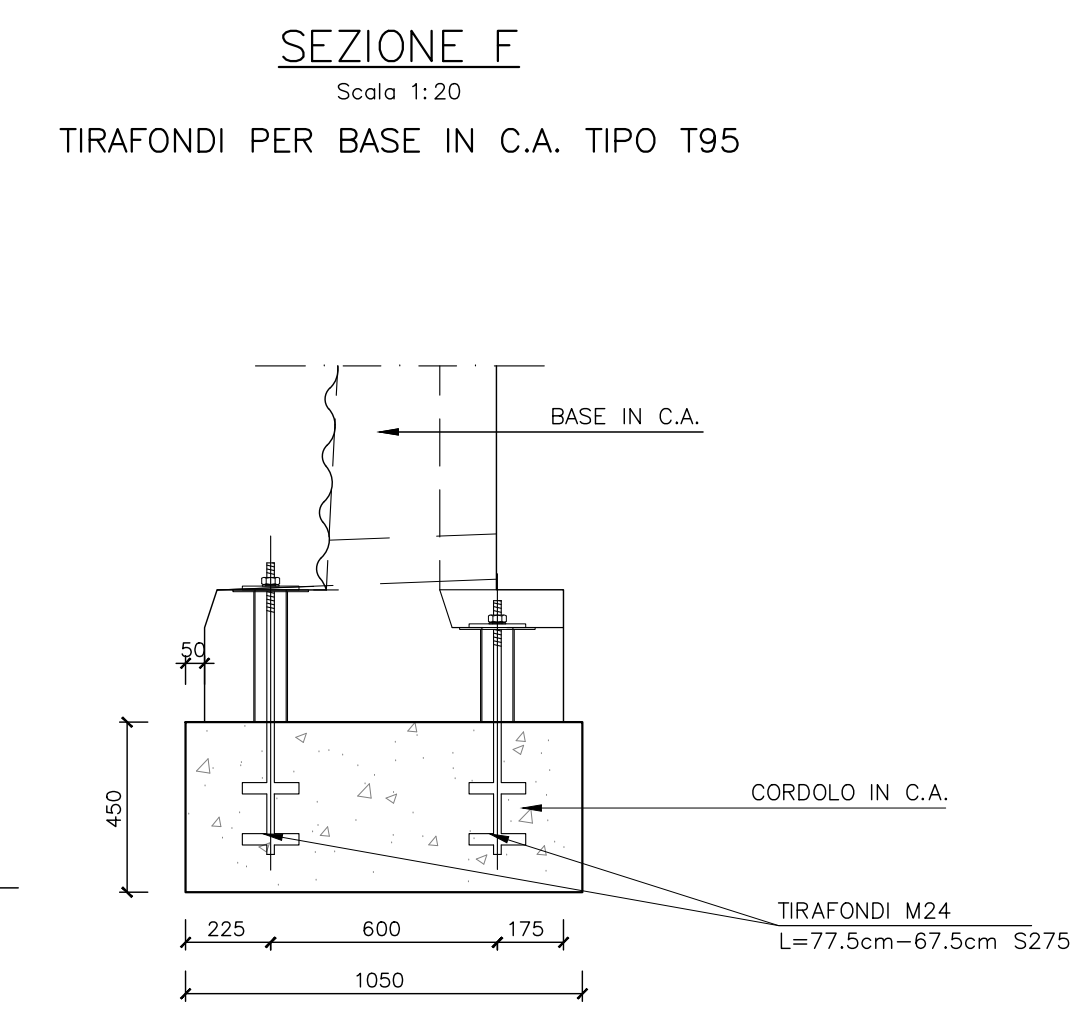
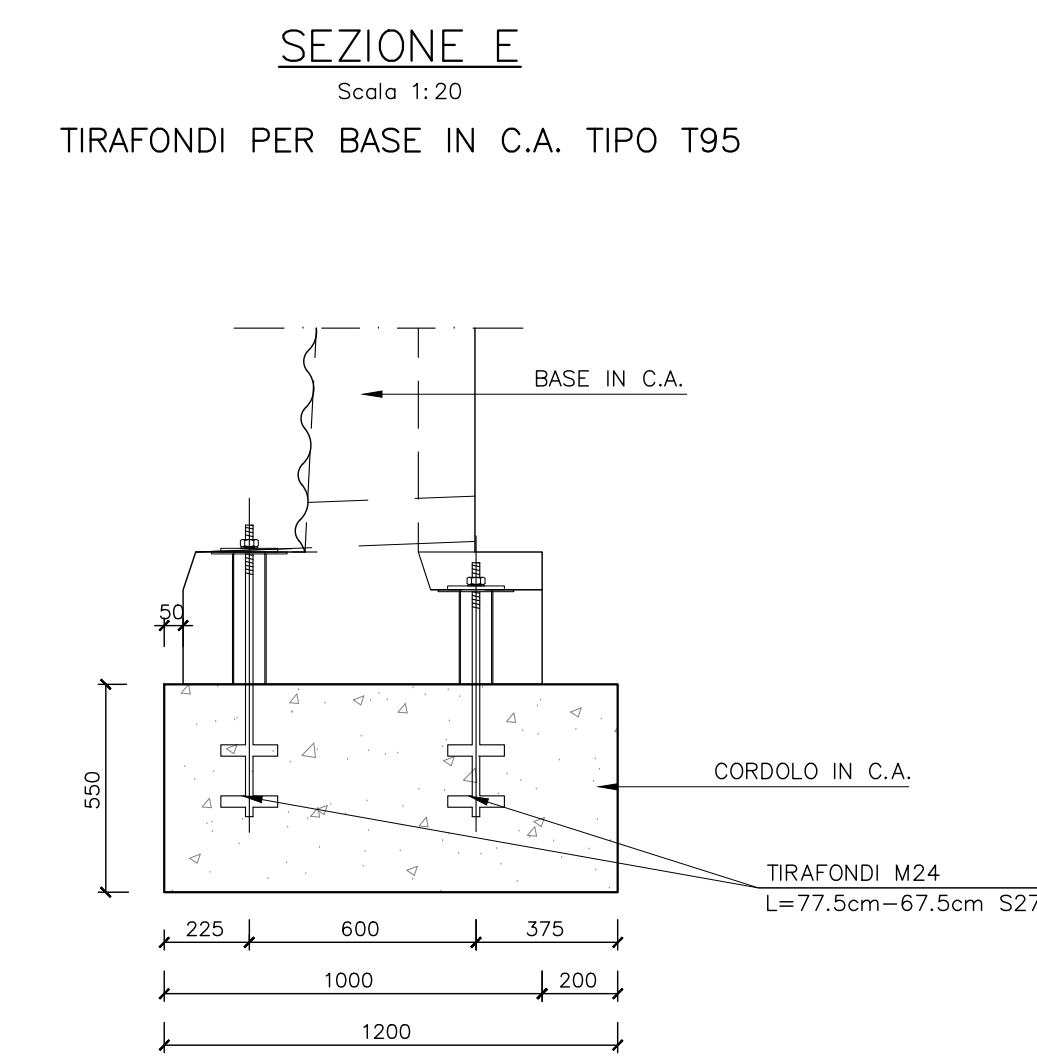
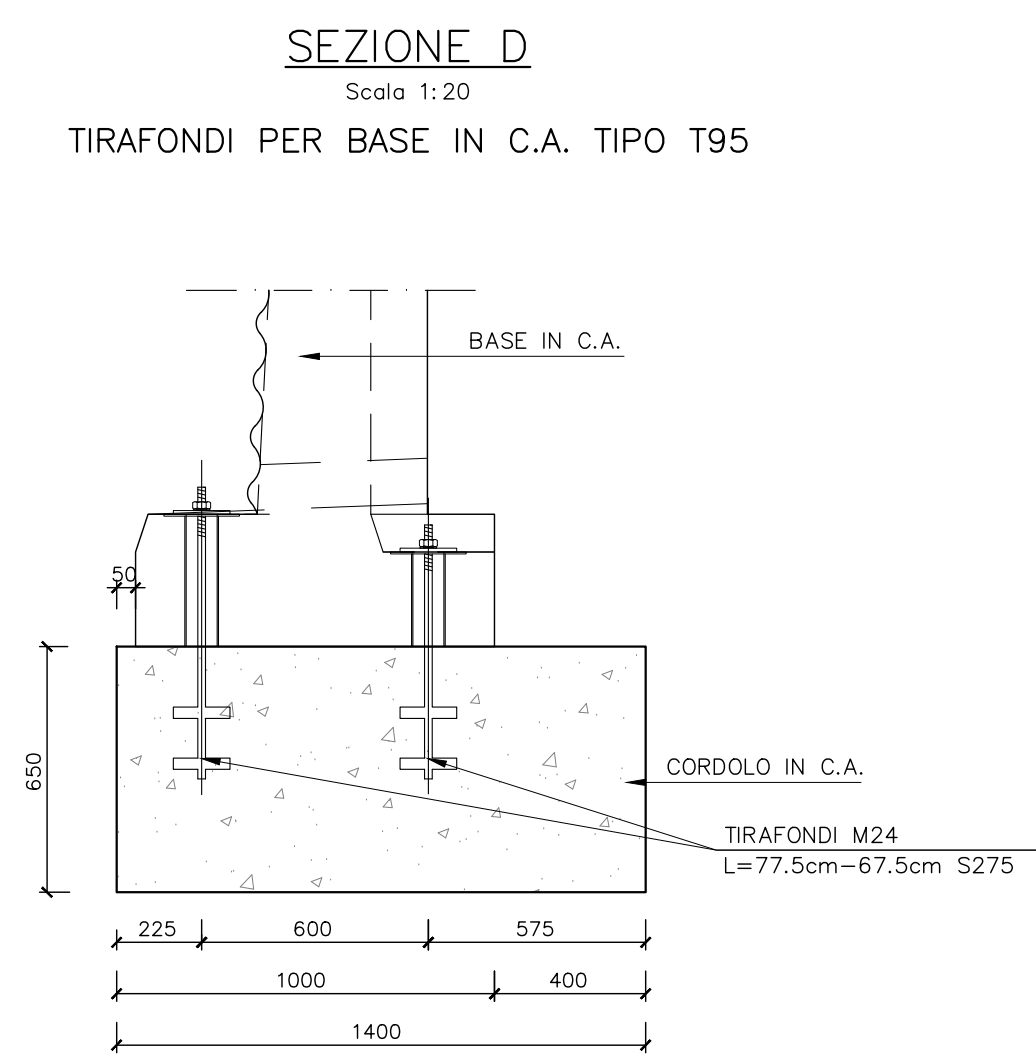
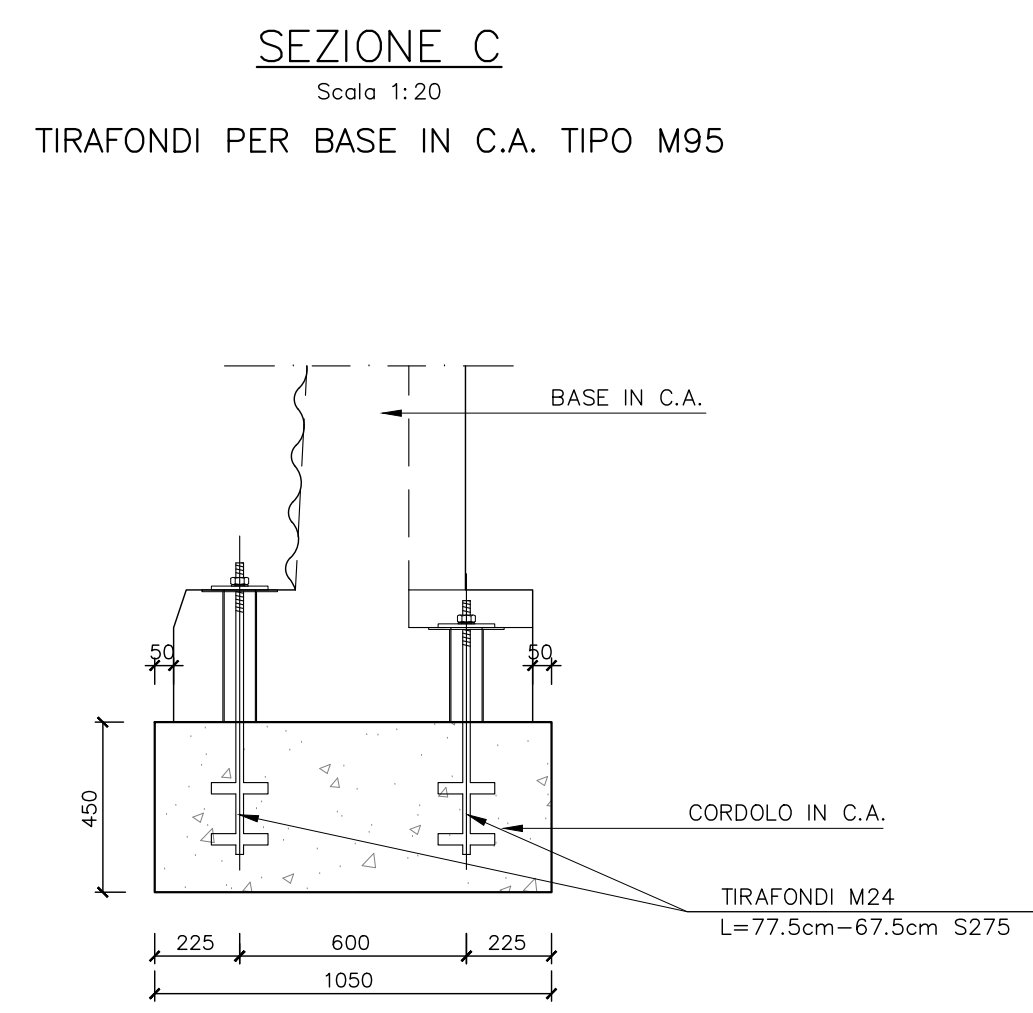
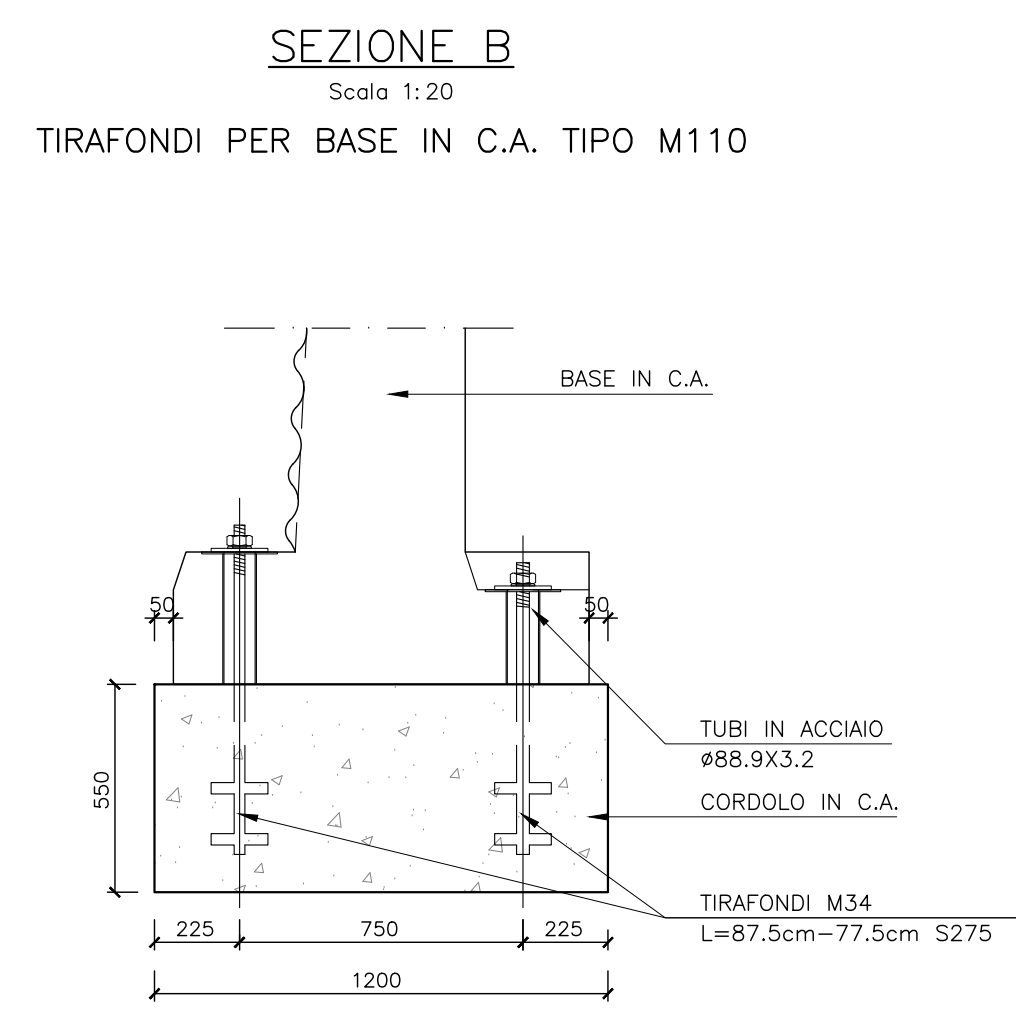
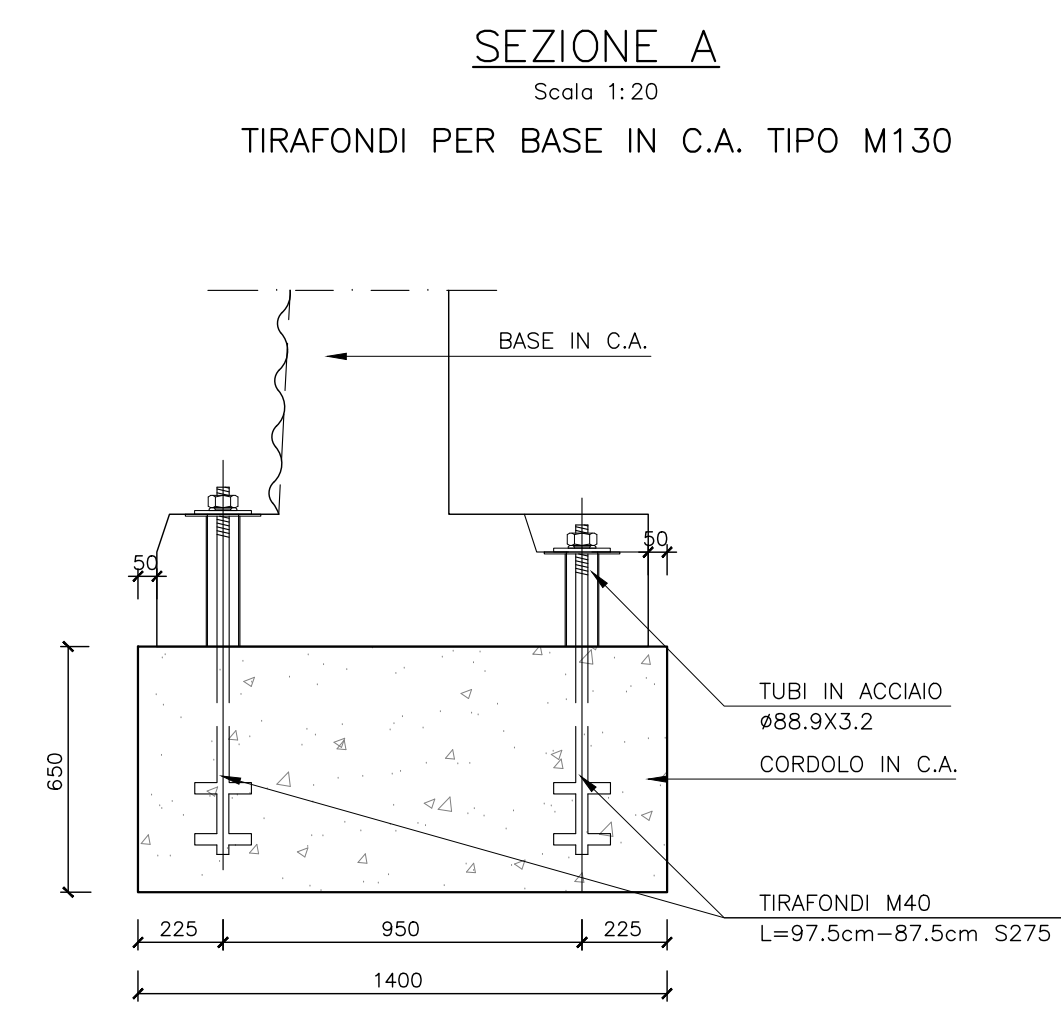

COMMITTENTE: **RFI** INFRASTRUTTURAZIONE ITALIANA GRUPPO FERROVIE DELLO STATO ITALIANE

PROGETTAZIONE: **ITALFERR** GRUPPO FERROVIE DELLO STATO ITALIANE

DIREZIONE TECNICA  
U.O. OPERE GEOTECNICHE

**PROGETTO FATTIBILITA' TECNICO ECONOMICA**

POTENZIAMENTO INFRASTRUTTURALE ORTE-FALCONARA  
RADDOPPIO DELLA TRATTA PM228-CASTELPLANIO

BARRIERE ANTIRUMORE

CARPENTERIA GENERALE BARRIERE ANTIRUMORE  
TAV. 2

SCALA: VARIE

COMMESSA	LOTTO	FASE	ENTE	TIPO DOC.	OPERA/DISCIPLINA	PROG.	REV.
IR0F	00	R	11	PZ	BA0000	001	B

Revis.	Descrizione	Redatto	Data	Verificato	Data	Approvato	Data	Autorizzato	Data
A	EMISSIONE DEFINITIVA	P. Cuomo	Set 2021	M.E. Di Ferraro	Set 2021	C. Ursani	Set 2021		
B	EMISSIONE DEFINITIVA	P. Cuomo	Gen 2022	G. Maresca	Gen 2022	C. Ursani	Gen 2022		

File: m2f00r11f28a0000018.dwg n. Elab.: