

MURO TIPO S1
1:50

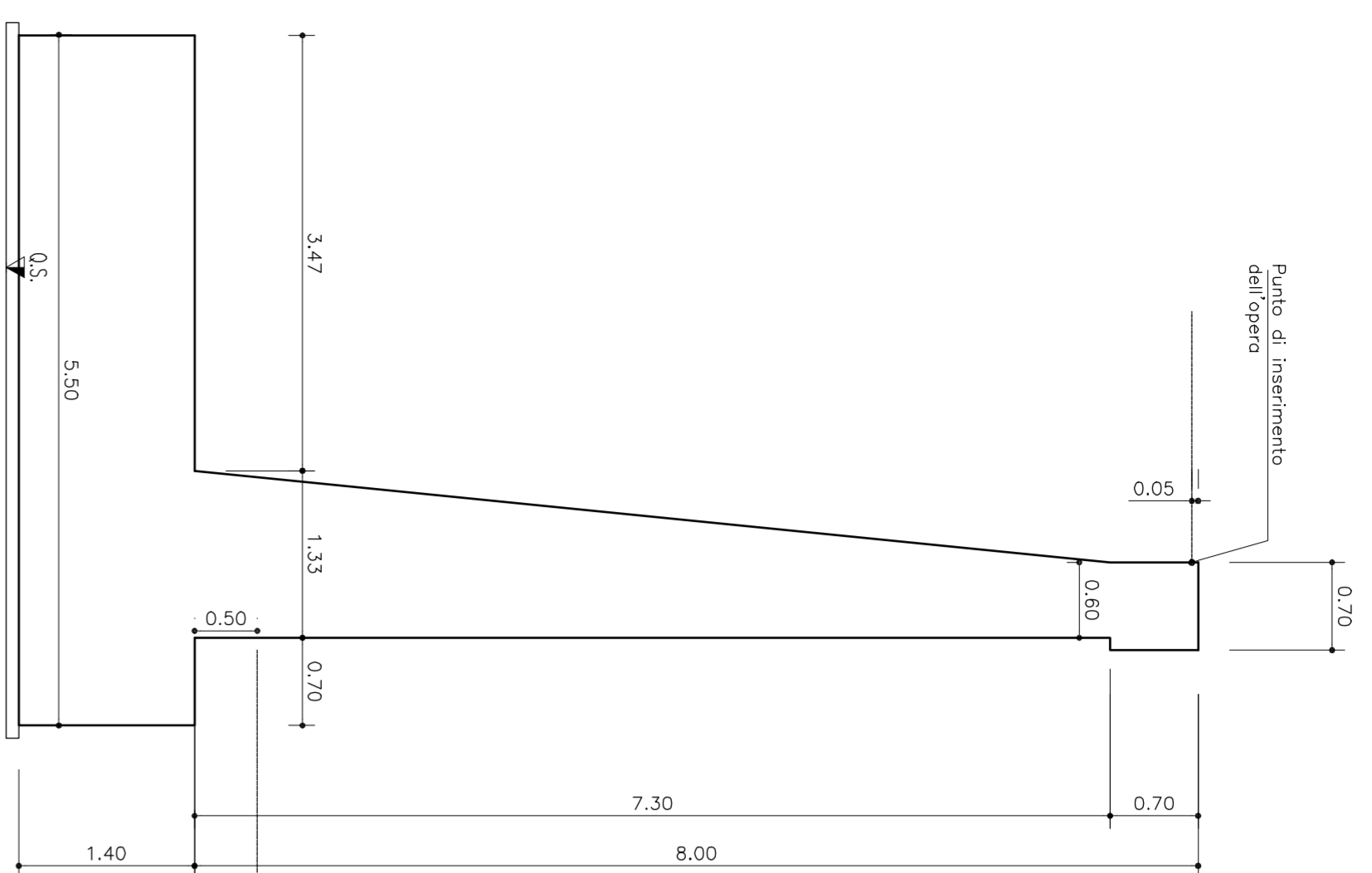

MURO TIPO S2
1:50

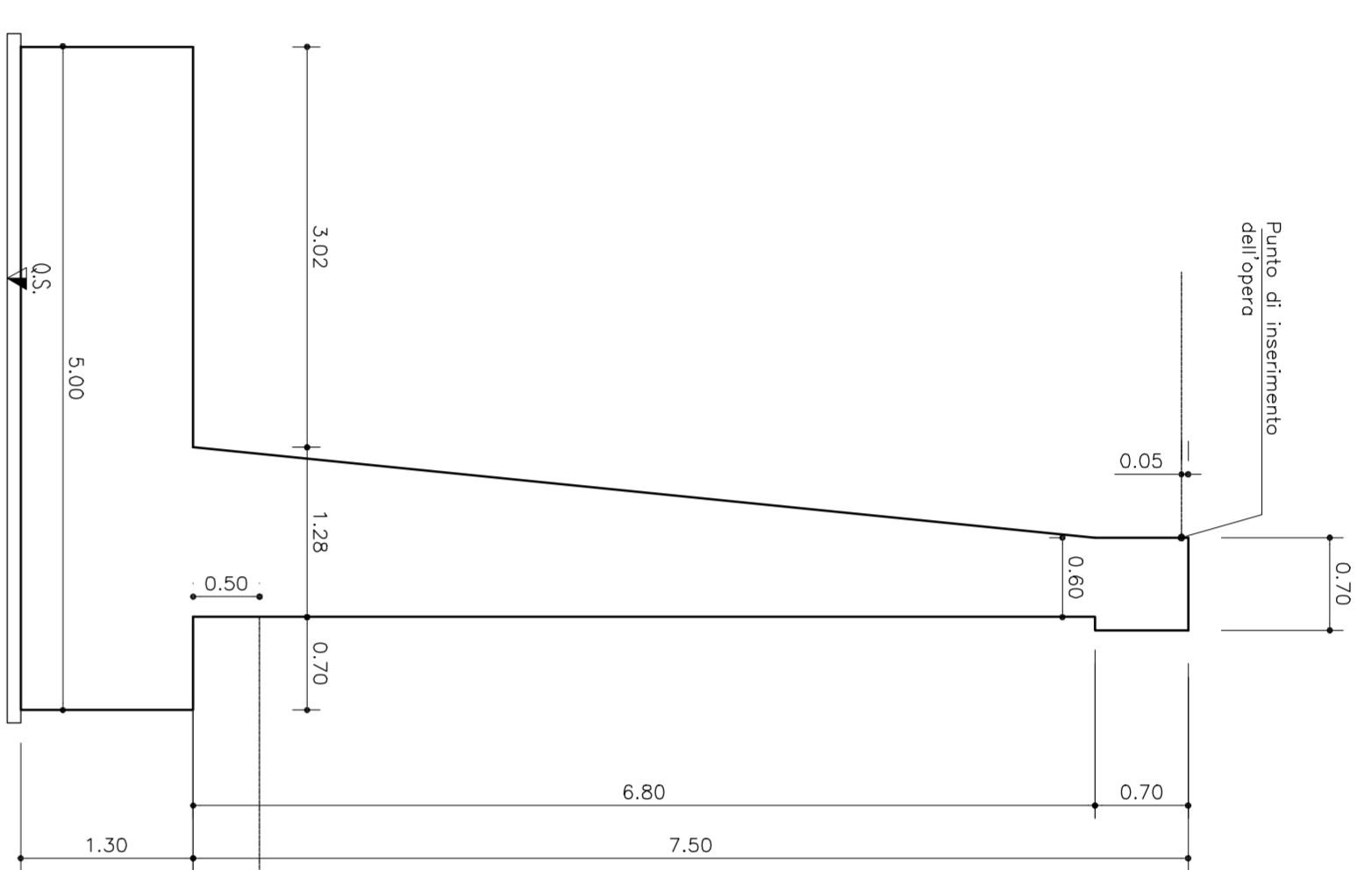

MURO TIPO S3
1:50

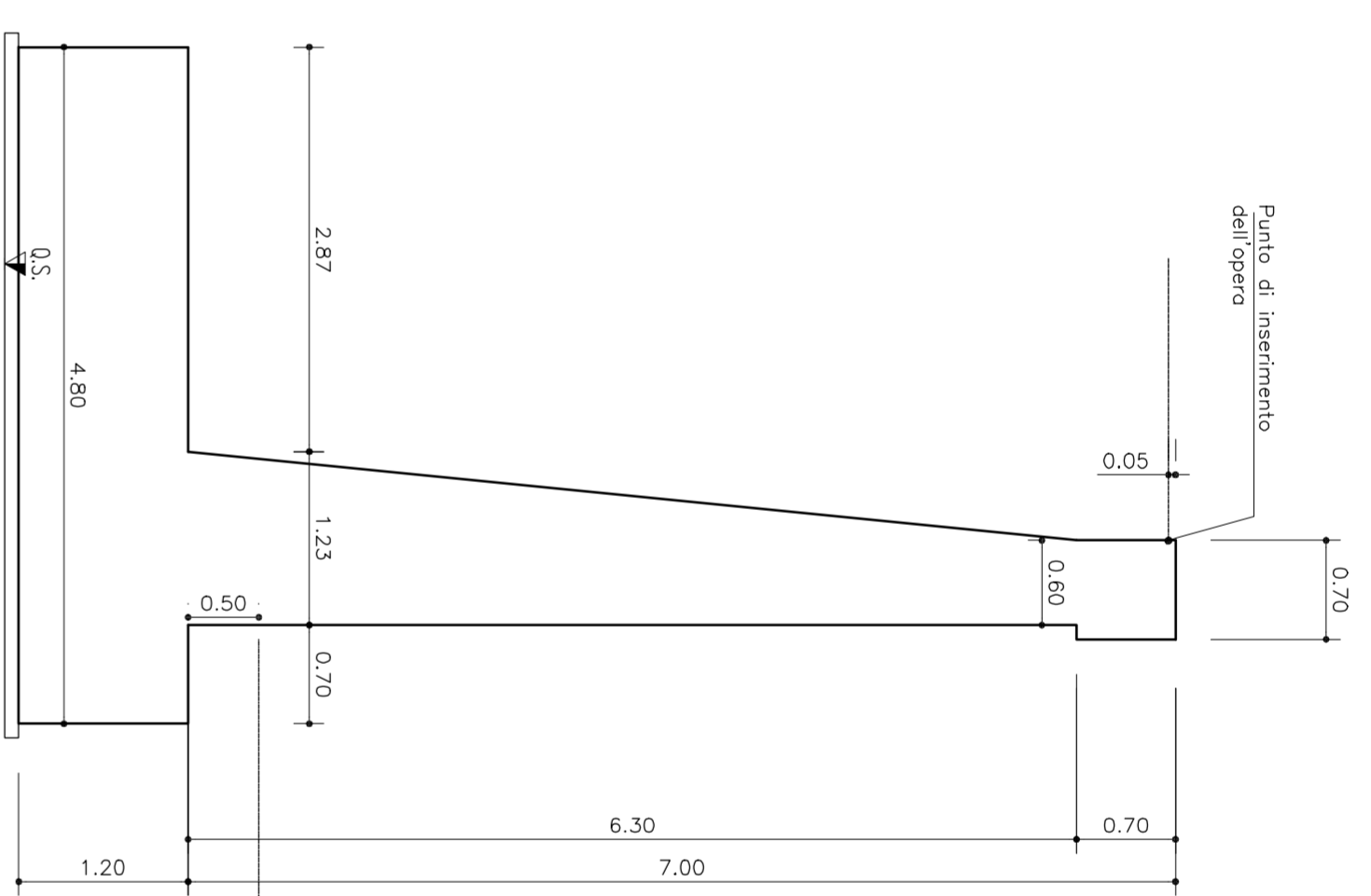

MURO TIPO S4
1:50

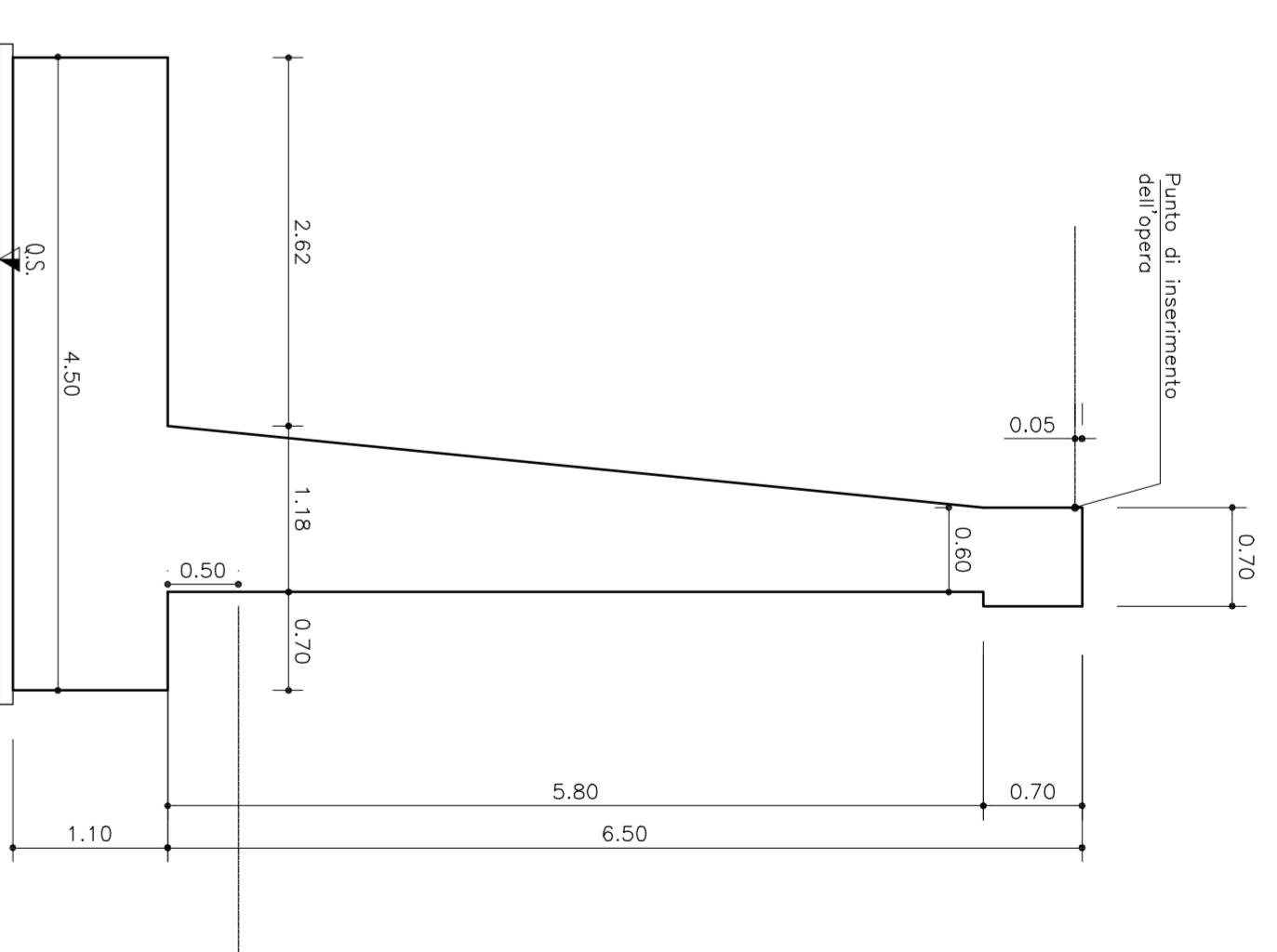

SOVRAPPOSIZIONE E COPRIFERRO
1:10

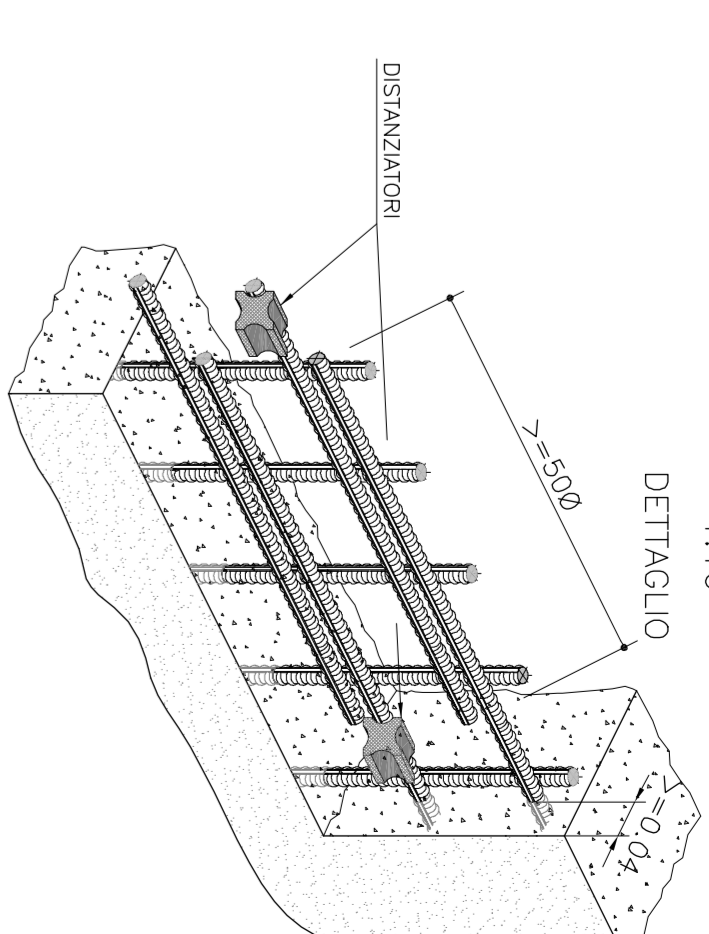

MURO TIPO S5
1:50

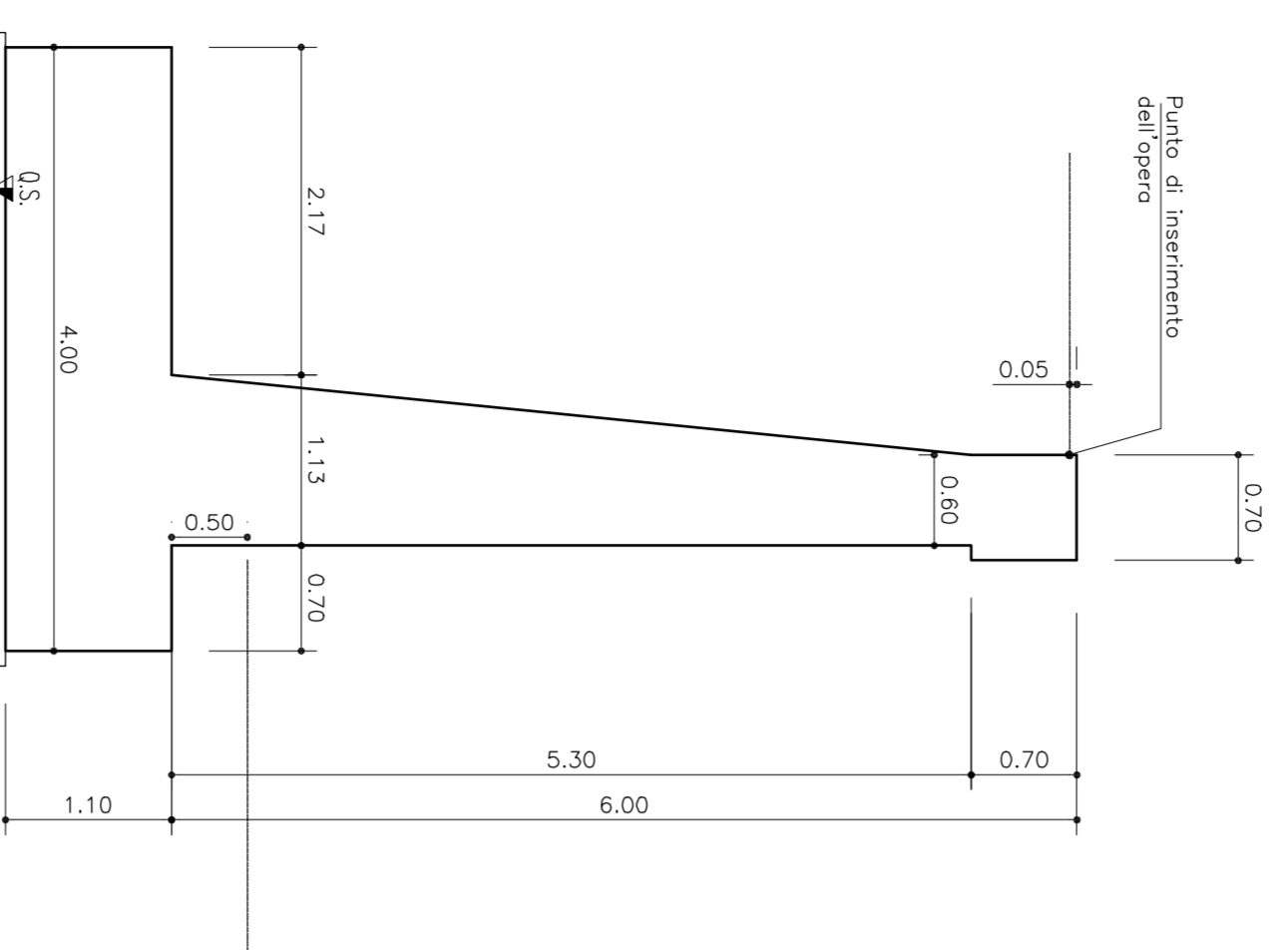

MURO TIPO S6
1:50

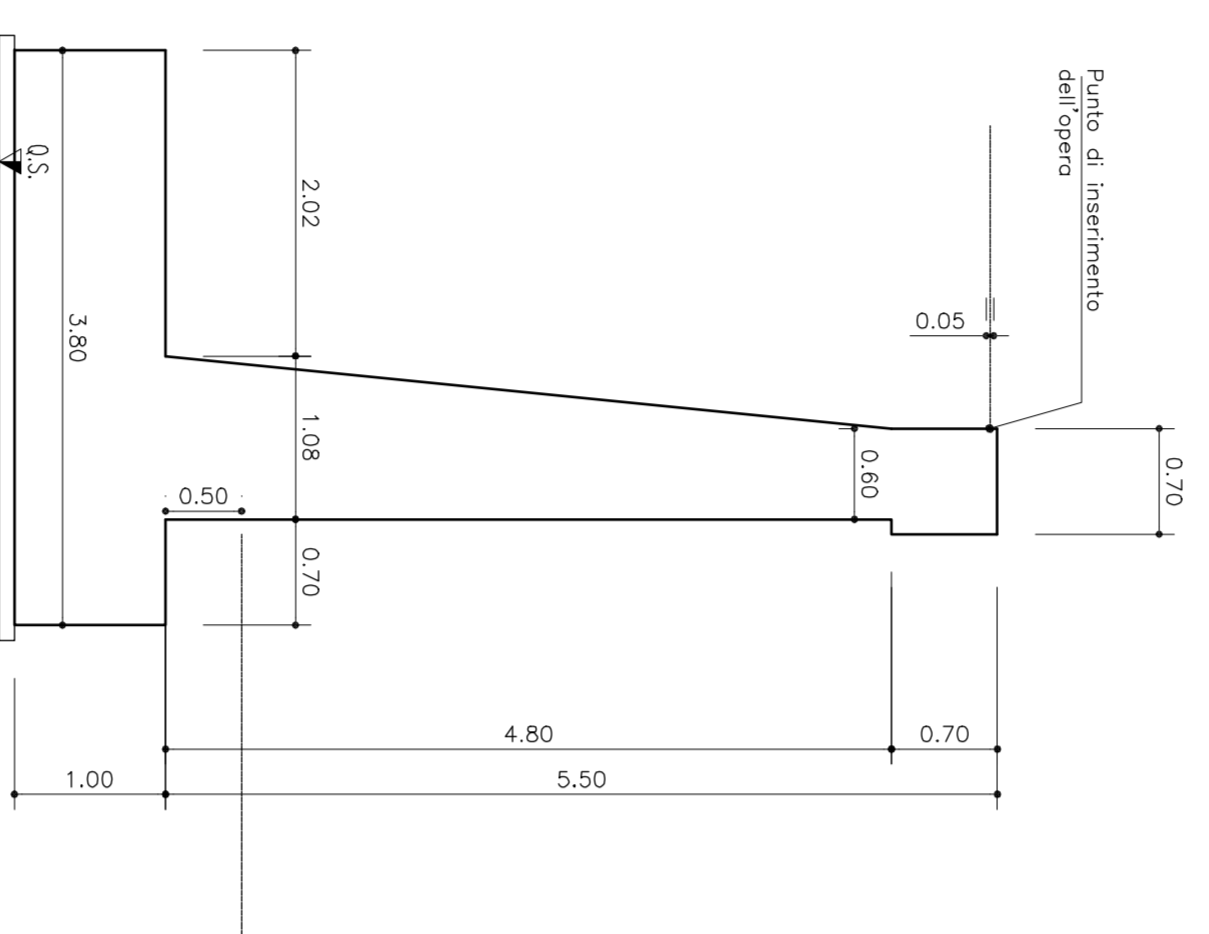

MURO TIPO S7
1:50

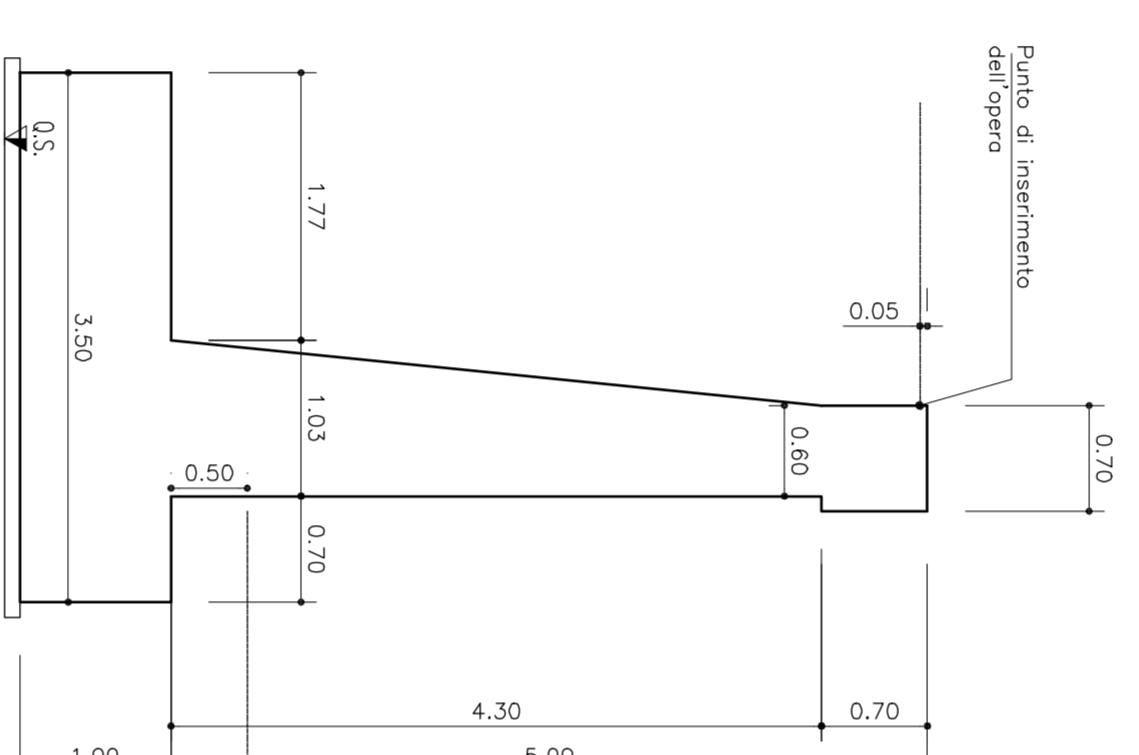

MURO TIPO S8
1:50

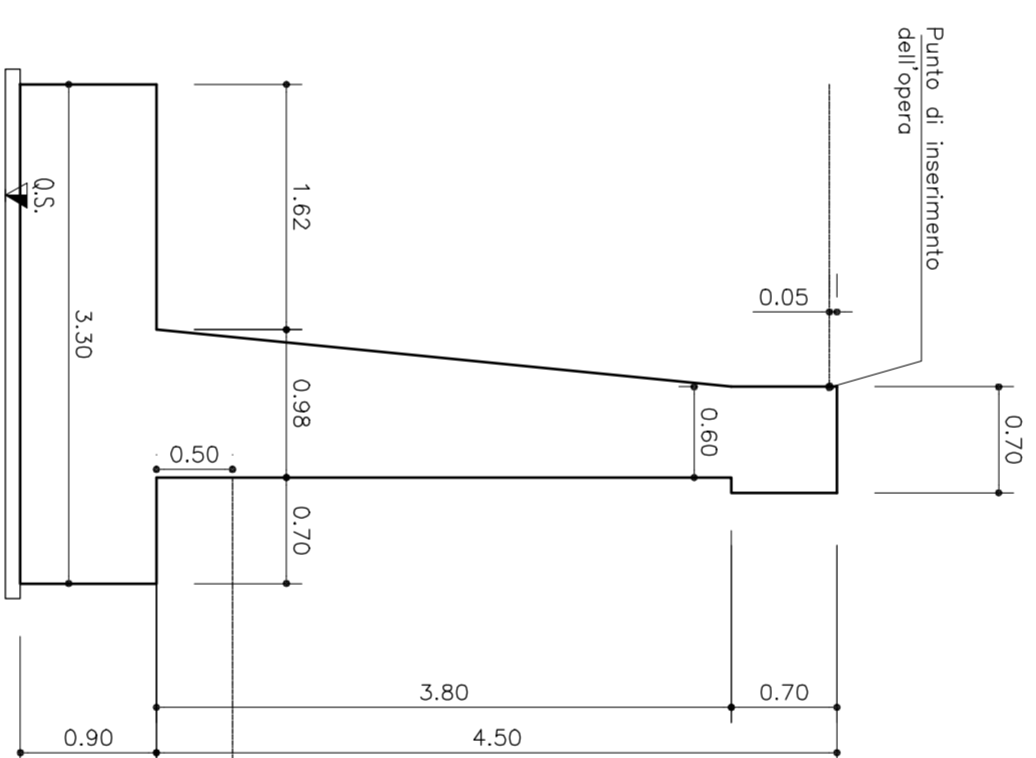

MURO TIPO S9
1:50

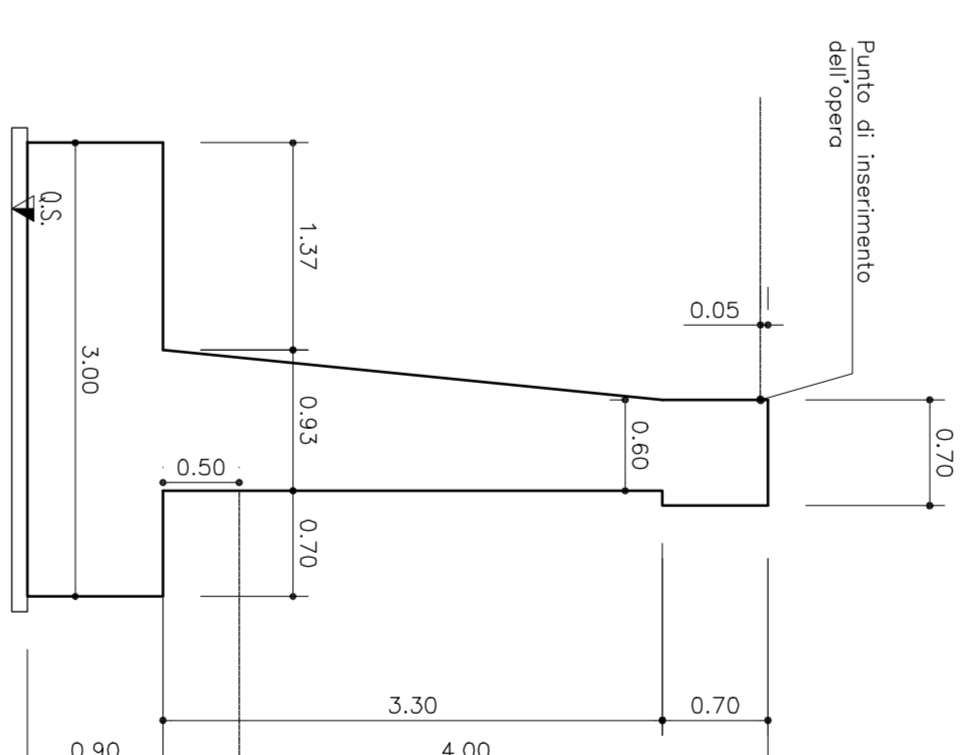

SPECIFICHE PIEGATURA E POSA FERRI

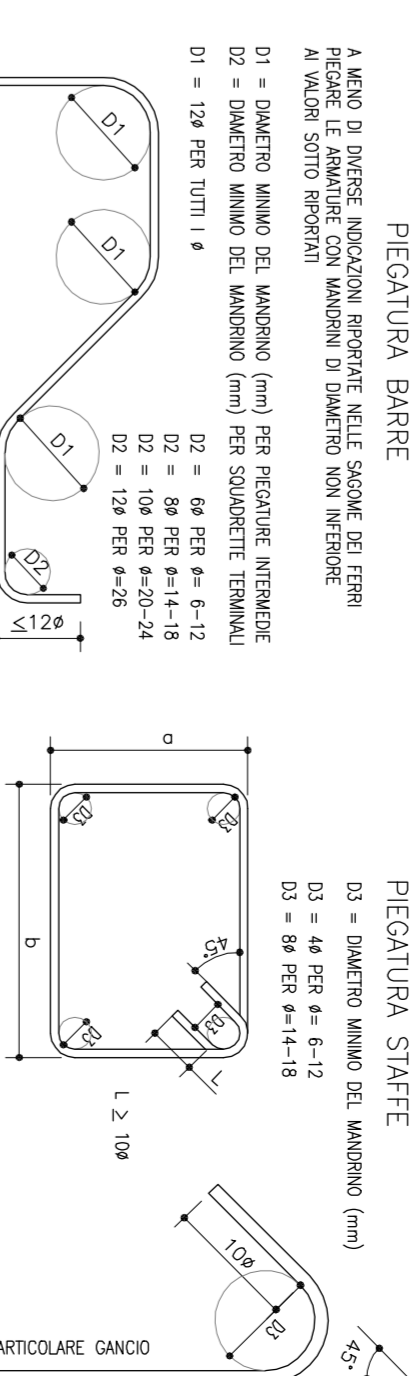

PIEGATURA BARRE

PIEGATURA SIFTE

SOVRAPPOSIZIONI

COPRIFERRO

INTERCORSO

SPLU (UNICI/GRATE)

TABELLA MATERIALI

PER QUANTO NON SPECIFICATO NEL SECONDO, IN PARTICOLARE, RELATIVAMENTE ALLE CARATTERISTICHE DEI MATERIALI, SI RIFERISCE ALLE TABELLE TECNICHE DI SECONDO GRADO.

ACCIAMI

ACCIAIO PER ARMATURE ONDULATE

OPEREZZI

COPRIFERRO

MURO TIPO S10
1:50

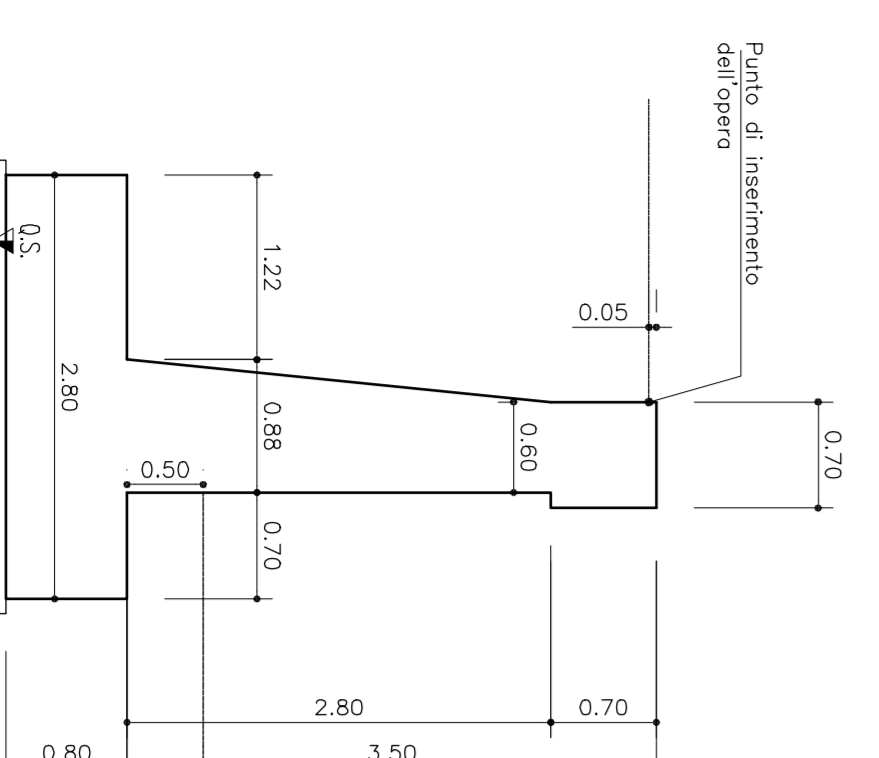

MURO TIPO S11
1:50

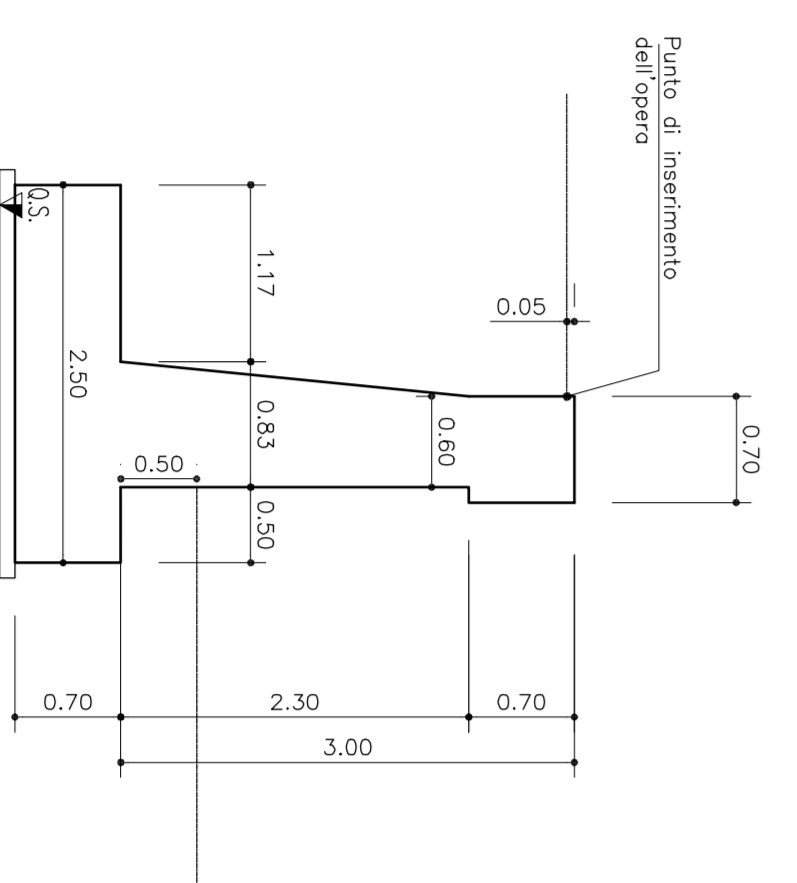

MURO TIPO S12
1:50

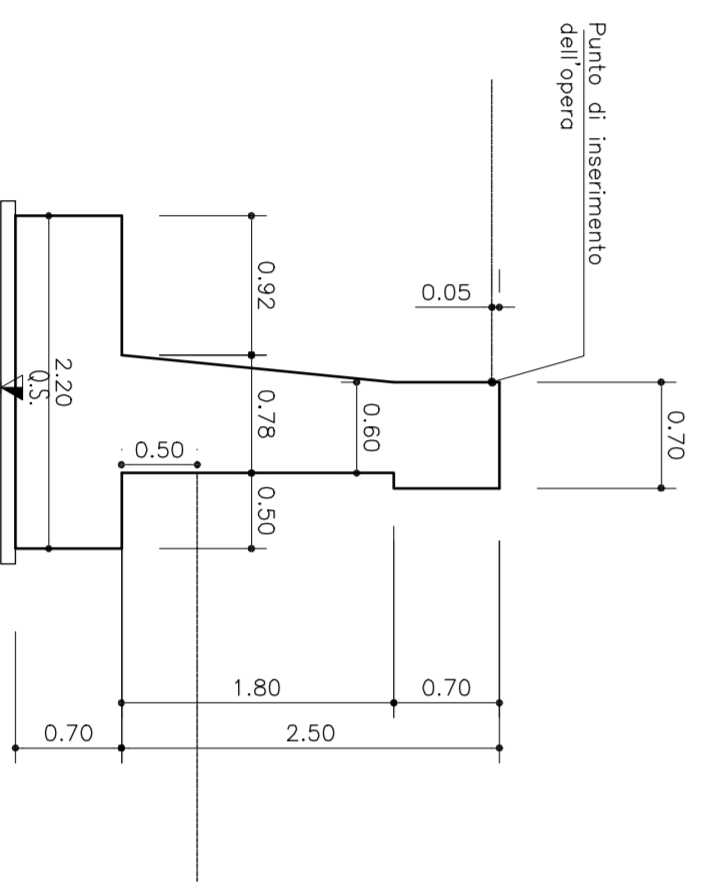

MURO TIPO S13
1:50

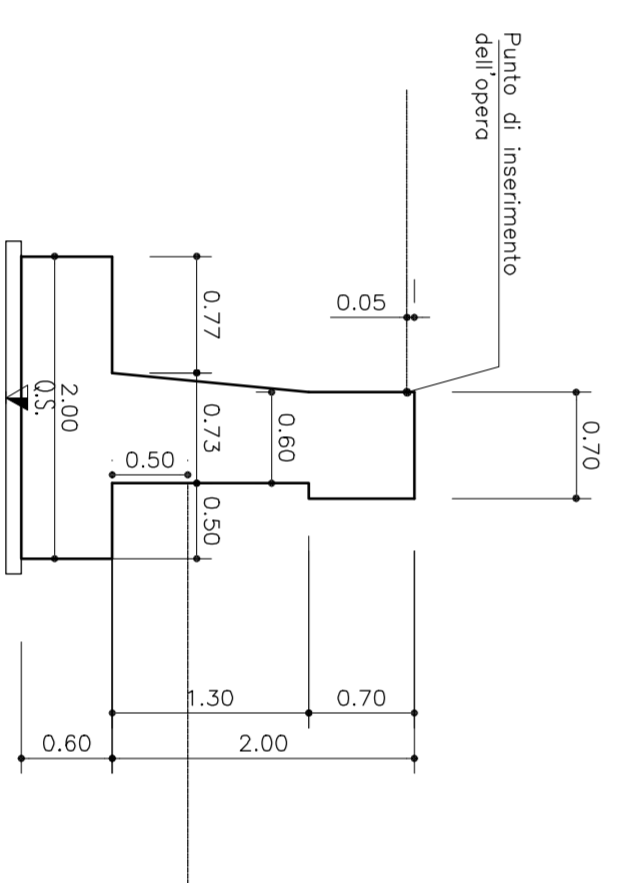

MURO TIPO S14
1:50

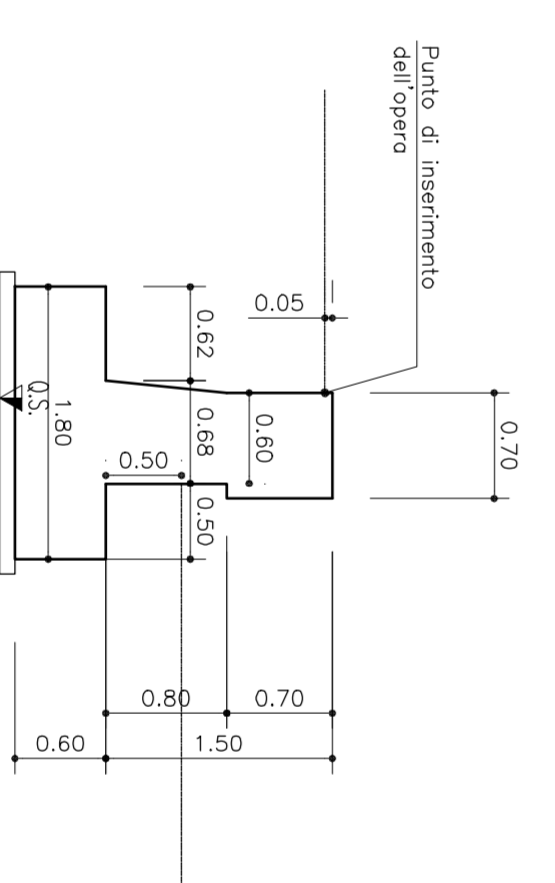

MURO TIPO S15
1:50

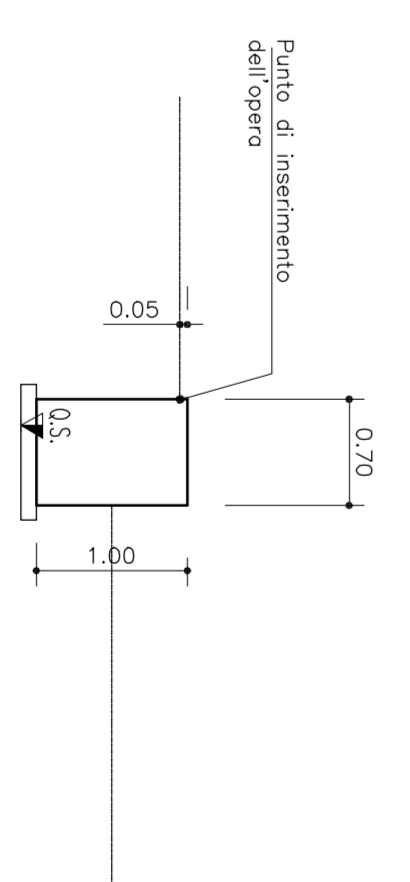

GALLERIE NATURALI

ELABORATI GENERALI

MURI DI SOSTEGNO IN C.A.

CARPENTERIE E PARTICOLARI COSTRUTTIVI

IL RESPONSABILE PROGETTAZIONE

IL RESPONSABILE ANTINCENDIO

IL RESPONSABILE ANTISISMICO

spesa

STAMPATO IN ITALIA

autostade // per l'Italia

REDAZIONE E AMMINISTRAZIONE

Autostade // per l'Italia

REDAZIONE E AMMINISTRAZIONE