

COMMITTENTE:



DIREZIONE LAVORI:



APPALTATORE:



PROGETTAZIONE:

MANDATARIA



MANDANTI



IL DIRETTORE DELLA PROGETTAZIONE:

Ing. L. LACCOPO

Responsabile progettazione fra le varie prestazioni specialistiche

### PROGETTO ESECUTIVO

### ITINERARIO NAPOLI-BARI RADDOPPIO TRATTA CANCELLO - BENEVENTO II LOTTO FUNZIONALE FRASSO TELESINO - VITULANO 2° E 3° SUBLOTTO TELESE - SAN LORENZO - VITULANO

DISEGNO

ARMAMENTO

ALLACCI PROVVISORI E PRECEDENZE

Album Sezioni deviata "E"

APPALTATORE		SCALA:
IL DIRETTORE TECNICO  M. FERRONI		1:200

COMMESSA    LOTTO    FASE    ENTE    TIPO DOC.    OPERA/DISCIPLINA    PROGR.    REV.

IF2R    02    E    ZZ    W9    SF00000    008    B

Rev.	Descrizione	Redatto	Data	Verificato	Data	Approvato	Data	Autorizzato Data
A	EMISSIONE	L. Camilli	23/06/2021	G. Abbate	24/06/2021	A. Rezzi	24/06/2021	IL PROGETTISTA L. LACCOPO  30/10/2021
B	EMISSIONE A SEGUITO DI RDV	L. Camilli	29/10/2021	G. Gramolini	30/10/2021	A. Rezzi	30/10/2021	

File: IF2R.0.2.E.ZZ.W9.SF.00.0.0.008.B.dwg

n. Elab.:



























SEZIONE N.: 13  
 QT. PROGETTO: 102,964  
 DIST.PROG.: 45800,000  
 DIST.PREC.: 25,000  
 DIST.SUCC.: 25,000

SCALA 1:200

QT.RIF. 92,000

PARZIALI TERRENO		9,157	1,495	1,074	0,596	1,165	2,259	1,676	1,311	1,213	1,182	2,096	0,798	0,640	2,117	1,934	2,640	0,991	0,522	1,069	1,386	0,796	0,523	2,245										
QUOTE TERRENO	-95,156		-94,009	-100,840	-100,796	-100,711	-100,578	-101,130		-102,150	-102,540	-102,630	-102,550	-102,470		-102,020	-101,840	-101,690		-101,058	-101,000	-100,889	-100,000	-99,141	-99,000	-98,039	-98,000	-97,653	-97,347	-97,296	-97,648	-97,669		
QUOTA RILEVATO																																		
PARZIALI RILEVATO																																		
PARZIALI SUBBALLAST/MISTO																																		
QUOTA SUBBALLAST/MISTO																																		

DEVIATA E - Quota: 102,964  
 LS - Quota: 102,958

SCAVI E BONIFICHE	
SCOTICO RILEVATO	- m
SCOTICO	5,566 m
BONIFICA	4,328 m
FOSSO	0,358 m <sup>2</sup>
GRADONATURA	2,416 m
RILEVATI	
ANTICAPILLARE	- m <sup>2</sup>
GEOTESSILE	- m
RILEVATO	2,517 m <sup>2</sup>
TERRENO VEGETALE	2,165 m
SOVRASTRUTTURA FERROVIARIA	
SUPERCOMPATTATO 30CM	8,720 m
MISTO STABILIZZATO 20CM	8,404 m
PIATTAFORMA CORPO FERROVIARIO	8,404 m

SEZIONE N.: 14  
 QT. PROGETTO: 102,882  
 DIST.PROG.: 45825,000  
 DIST.PREC.: 25,000  
 DIST.SUCC.: 25,000

SCALA 1:200

QT.RIF. 95,000

PARZIALI TERRENO		3,874	7,480	2,008	0,905	1,775	0,779	2,370	0,589	1,117	0,581	0,724	0,879	2,517	0,485	1,990	1,285	6,464	2,935						
QUOTE TERRENO		-102,544	-102,468	-102,114	-102,120	-102,237	-102,599	-102,694	-102,555	-102,494	-102,733	-102,472	-102,407	-102,217	-102,085	-102,162	-101,313	-101,313	-101,272	-100,965	-101,000	-100,046	-99,974	-99,764	
QUOTA RILEVATO						102,393	102,064	102,064	102,100	103,024	102,653	103,016	102,760	102,692	102,648	102,694	102,114	102,064	102,159	101,313	100,813	100,813	101,121		
PARZIALI RILEVATO						0,494	0,500	0,600	1,302	1,233	0,535	0,506	0,708	0,684	0,510	0,575	0,774	1,671	0,600	1,268	0,500	0,500			
PARZIALI SUBBALLAST/MISTO																									
QUOTA SUBBALLAST/MISTO																									-102,064

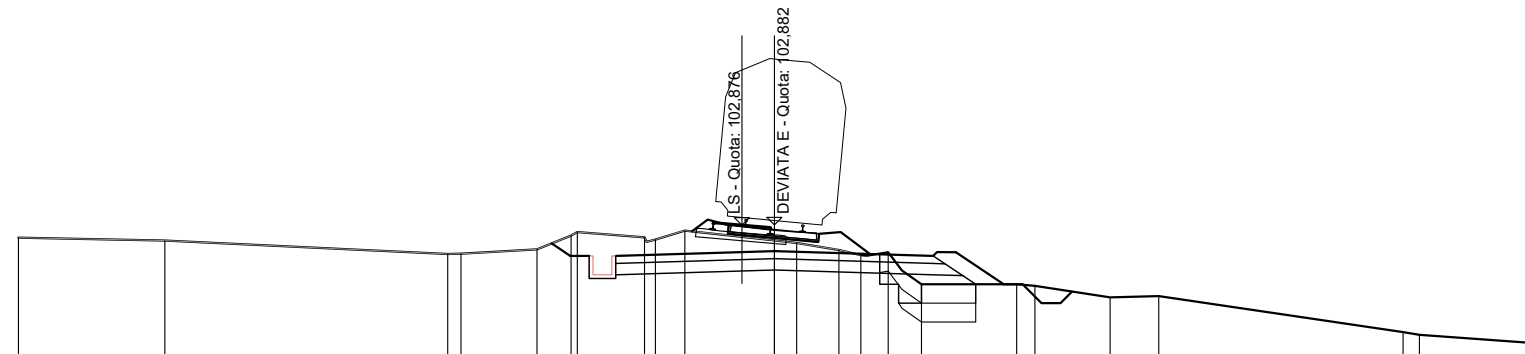

SCAVI E BONIFICHE	
SCOTICO RILEVATO	- m
SCOTICO	4,569 m
BONIFICA	4,569 m
FOSSO	0,370 m <sup>2</sup>
RILEVATI	
ANTICAPILLARE	- m <sup>2</sup>
GEOTESSILE	- m
RILEVATO	4,339 m <sup>2</sup>
TERRENO VEGETALE	2,198 m
SOVRASTRUTTURA FERROVIARIA	
SUPERCOMPATTATO 30CM	3,328 m
MISTO STABILIZZATO 20CM	3,012 m
PIATTAFORMA CORPO FERROVIARIO	3,140 m

SEZIONE N.: 15  
 QT. PROGETTO: 102,800  
 DIST.PROG.: 45850,000  
 DIST.PREC.: 25,000  
 DIST.SUCC.: 25,000

SCALA 1:200

QT.RIF. 95,000

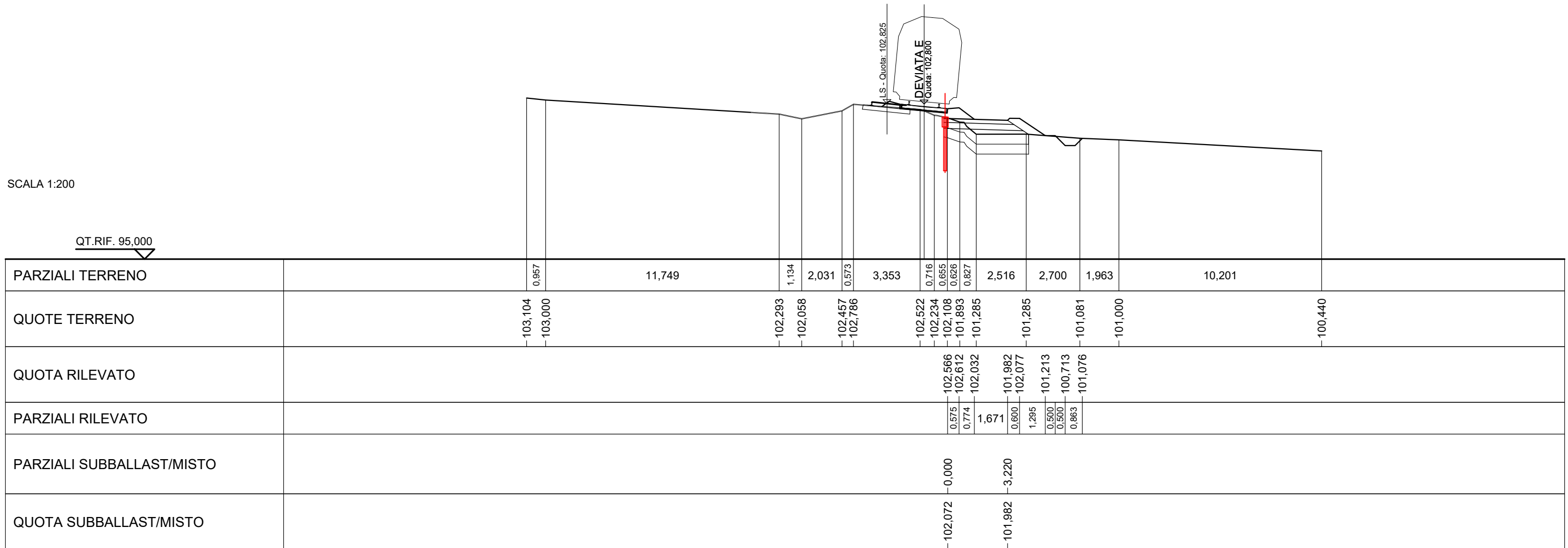



SCAVI E BONIFICHE	
SCOTICO RILEVATO	- m
SCOTICO	6,101 m
BONIFICA	6,093 m
FOSSO	0,449 m <sup>2</sup>
RILEVATI	
ANTICAPILLARE	- m <sup>2</sup>
GEOTESSILE	- m
RILEVATO	5,134 m <sup>2</sup>
TERRENO VEGETALE	1,877 m
SOVRASTRUTTURA FERROVIARIA	
SUPERCOMPATTATO 30CM	5,180 m
MISTO STABILIZZATO 20CM	4,864 m
PIATTAFORMA CORPO FERROVIARIO	5,013 m

SEZIONE N.: 16  
 QT. PROGETTO: 102,718  
 DIST.PROG.: 45875,000  
 DIST.PREC.: 25,000  
 DIST.SUCC.: 25,000

SCALA 1:200

QT.RIF. 95,000

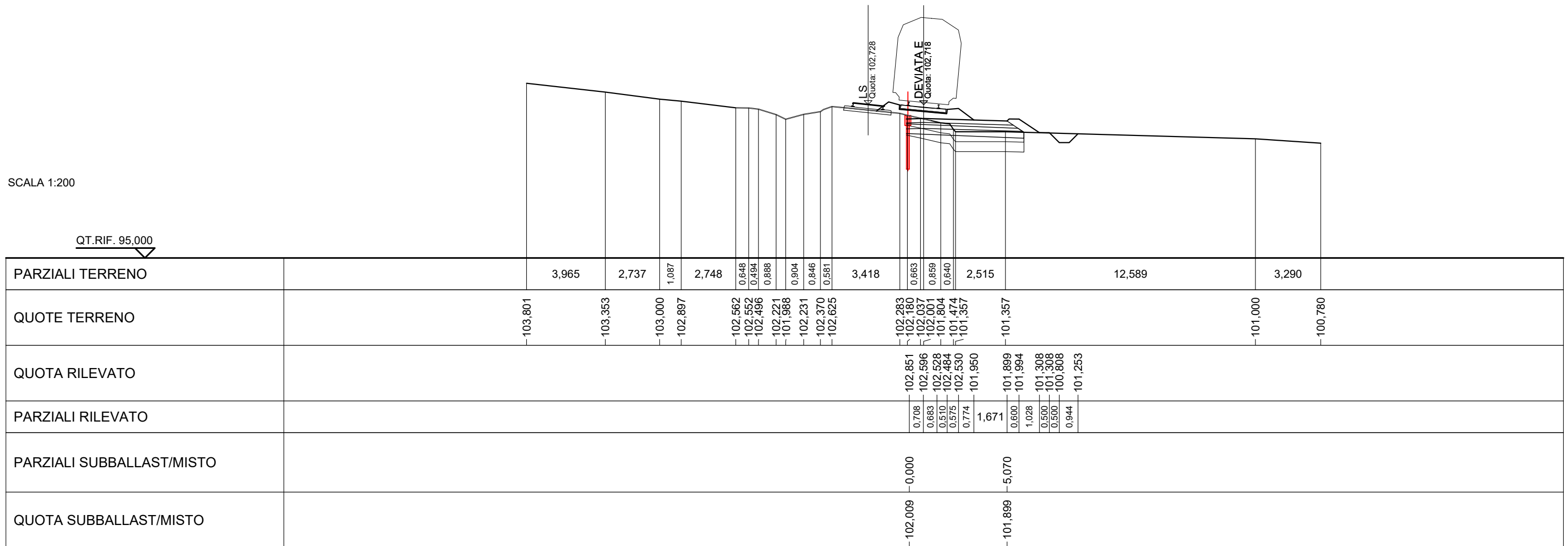



SCAVI E BONIFICHE	
SCOTICO RILEVATO	- m
SCOTICO	5,354 m
BONIFICA	5,398 m
FOSSO	0,352 m <sup>2</sup>
GRADONATURA	3,709 m
RILEVATI	
ANTICAPILLARE	2,847 m <sup>2</sup>
GEOTESSILE	13,724 m
RILEVATO	11,965 m <sup>2</sup>
TERRENO VEGETALE	2,474 m
SOVRASTRUTTURA FERROVIARIA	
SUPERCOMPATTATO 30CM	6,183 m
MISTO STABILIZZATO 20CM	5,863 m
PIATTAFORMA CORPO FERROVIARIO	6,023 m

SEZIONE N.: 18  
 QT. PROGETTO: 102,554  
 DIST.PROG.: 45925,000  
 DIST.PREC.: 25,000  
 DIST.SUCC.: 25,000

SCALA 1:200

QT.RIF. 95,000

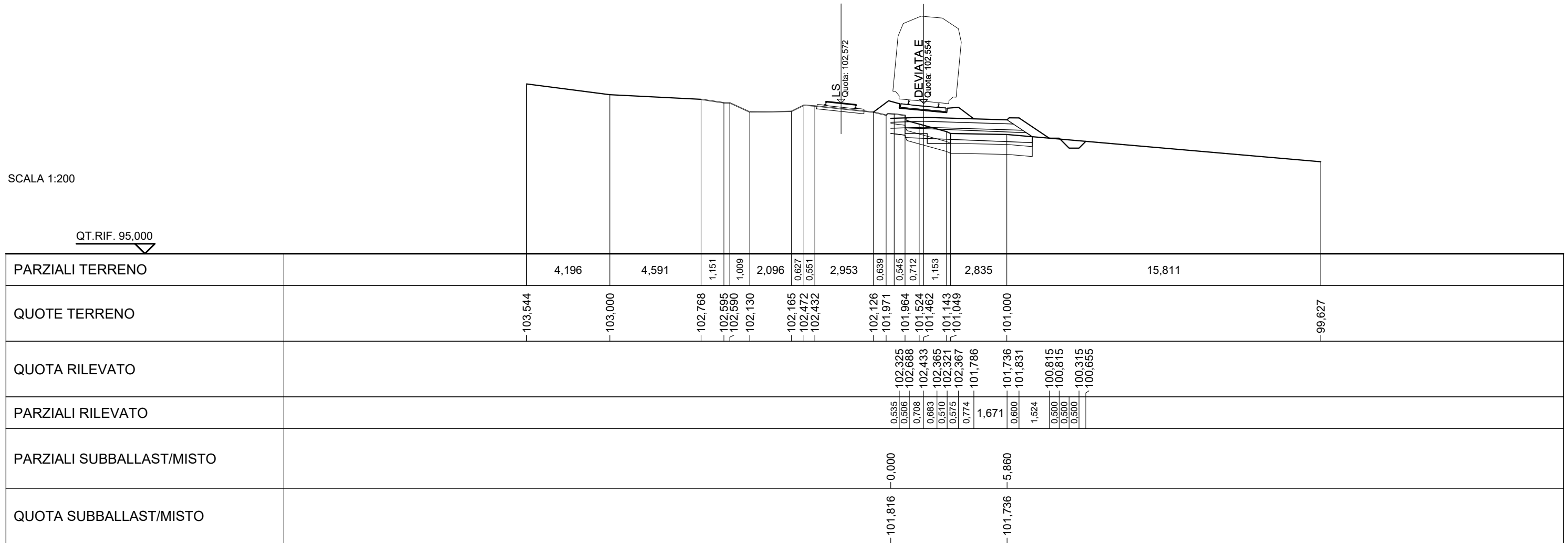

SCAVI E BONIFICHE	
SCOTICO RILEVATO	- m
SCOTICO	6,596 m
BONIFICA	7,601 m
FOSSO	0,278 m <sup>2</sup>
GRADONATURA	2,524 m
RILEVATI	
ANTICAPILLARE	3,530 m <sup>2</sup>
GEOTESSILE	15,116 m
RILEVATO	5,558 m <sup>2</sup>
TERRENO VEGETALE	3,114 m
SOVRASTRUTTURA FERROVIARIA	
SUPERCOMPATTATO 30CM	6,512 m
MISTO STABILIZZATO 20CM	6,195 m
PIATTAFORMA CORPO FERROVIARIO	6,354 m

SEZIONE N.: 19  
 QT. PROGETTO: 102,503  
 DIST.PROG.: 45950,000  
 DIST.PREC.: 25,000  
 DIST.SUCC.: 25,000

SCALA 1:200

QT.RIF. 94,500

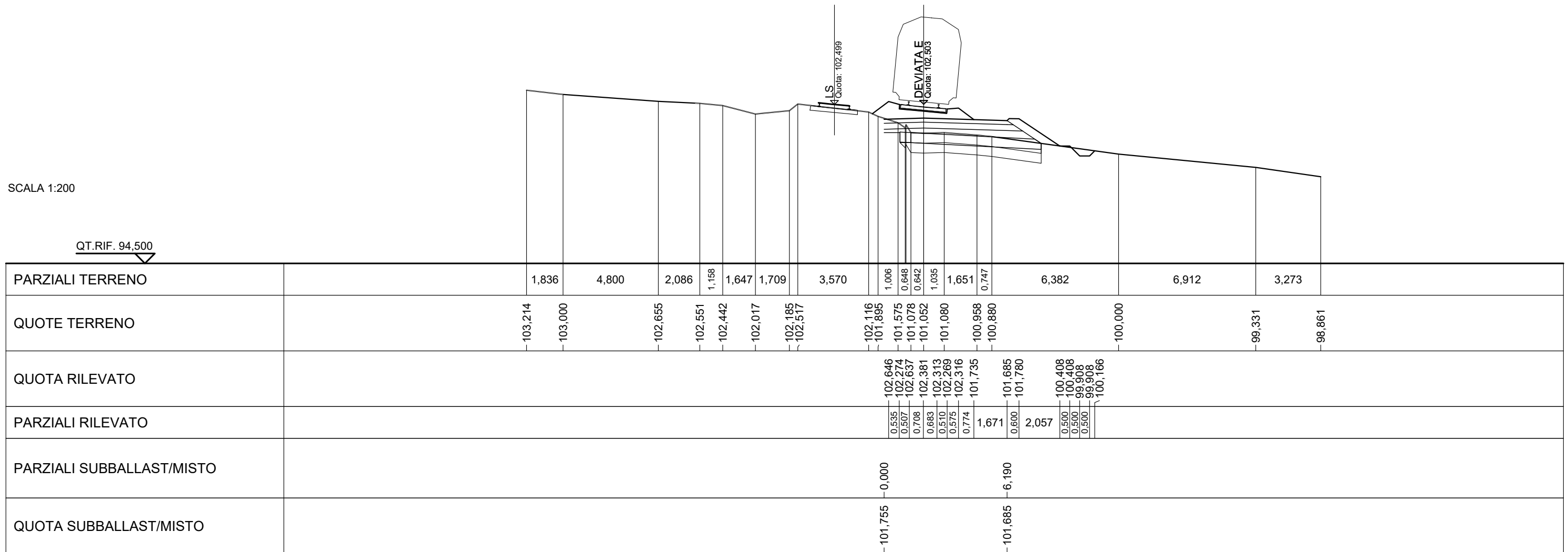



SCAVI E BONIFICHE	
SCOTICO RILEVATO	- m
SCOTICO	0,257 m
BONIFICA	0,257 m
FOSSO	0,366 m <sup>2</sup>
GRADONATURA	6,153 m
RILEVATI	
ANTICAPILLARE	1,660 m <sup>2</sup>
GEOTESSILE	7,659 m
RILEVATO	2,387 m <sup>2</sup>
TERRENO VEGETALE	3,503 m
SOVRASTRUTTURA FERROVIARIA	
SUPERCOMPATTATO 30CM	7,345 m
MISTO STABILIZZATO 20CM	6,971 m
PIATTAFORMA CORPO FERROVIARIO	6,971 m

SEZIONE N.: 21  
 QT. PROGETTO: 102,467  
 DIST.PROG.: 46000,000  
 DIST.PREC.: 25,000  
 DIST.SUCC.: 25,000

SCALA 1:200

QT.RIF. 94,000

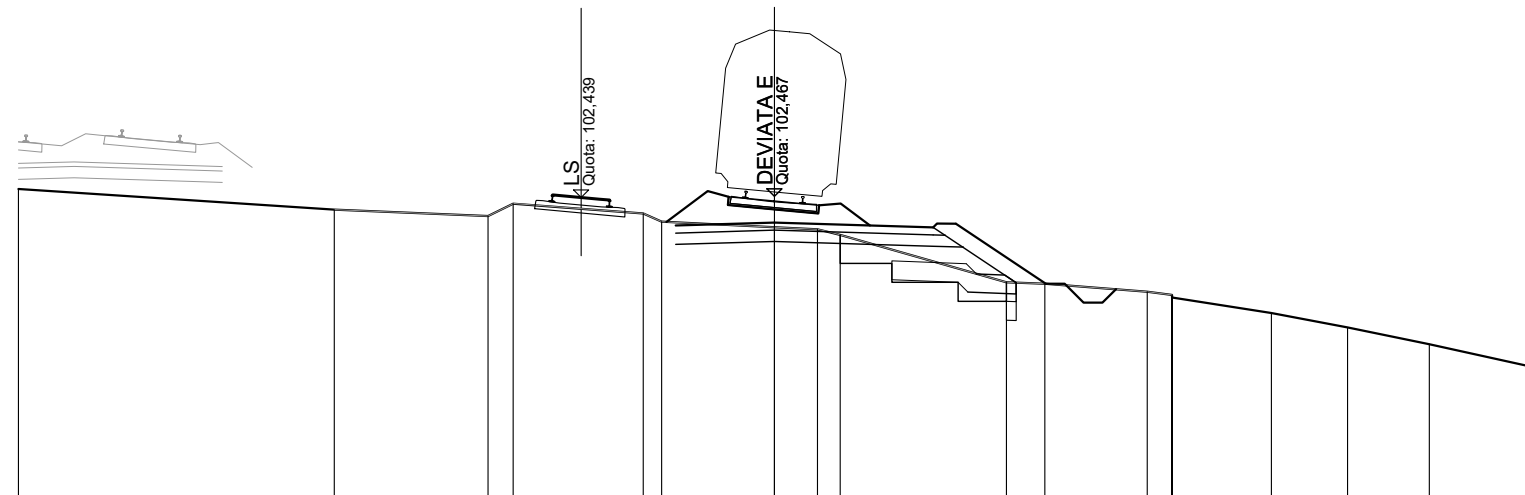

PARZIALI TERRENO				8,357	4,066	0,667	3,442	0,487	2,982	1,138	0,601	4,399	1,018	2,708	0,655	2,627	2,016	2,163	2,672										
QUOTE TERRENO	-102,662		-102,117		-101,947	-102,272		-102,016	-101,801		-101,653		-101,598	-101,447		-100,193	-100,158		-99,948	-99,861	-99,791		-99,381		-99,000		-98,559		-97,969
QUOTA RILEVATO										102,610	102,238	102,601	102,345	102,277	102,233	102,280	101,699	101,649	101,744	100,156	100,156	99,656	100,012						
PARZIALI RILEVATO										1,233	0,535	0,606	0,708	0,683	0,510	0,575	0,774	1,671	0,600	2,381	0,500	0,500	0,500						
PARZIALI SUBBALLAST/MISTO																													
QUOTA SUBBALLAST/MISTO										-101,699	-0,000									-101,649	-6,810								

SCAVI E BONIFICHE	
SCOTICO RILEVATO	- m
SCOTICO	1,988 m
BONIFICA	4,239 m
FOSSO	0,269 m <sup>2</sup>
GRADONATURA	5,782 m
RILEVATI	
ANTICAPILLARE	3,505 m <sup>2</sup>
GEOTESSILE	15,854 m
RILEVATO	3,944 m <sup>2</sup>
TERRENO VEGETALE	2,771 m
SOVRASTRUTTURA FERROVIARIA	
SUPERCOMPATTATO 30CM	7,583 m
MISTO STABILIZZATO 20CM	7,212 m
PIATTAFORMA CORPO FERROVIARIO	7,212 m

SEZIONE N.: 22  
 QT. PROGETTO: 102,450  
 DIST.PROG.: 46025,000  
 DIST.PREC.: 25,000  
 DIST.SUCC.: 25,000

SCALA 1:200

QT.RIF. 94,500

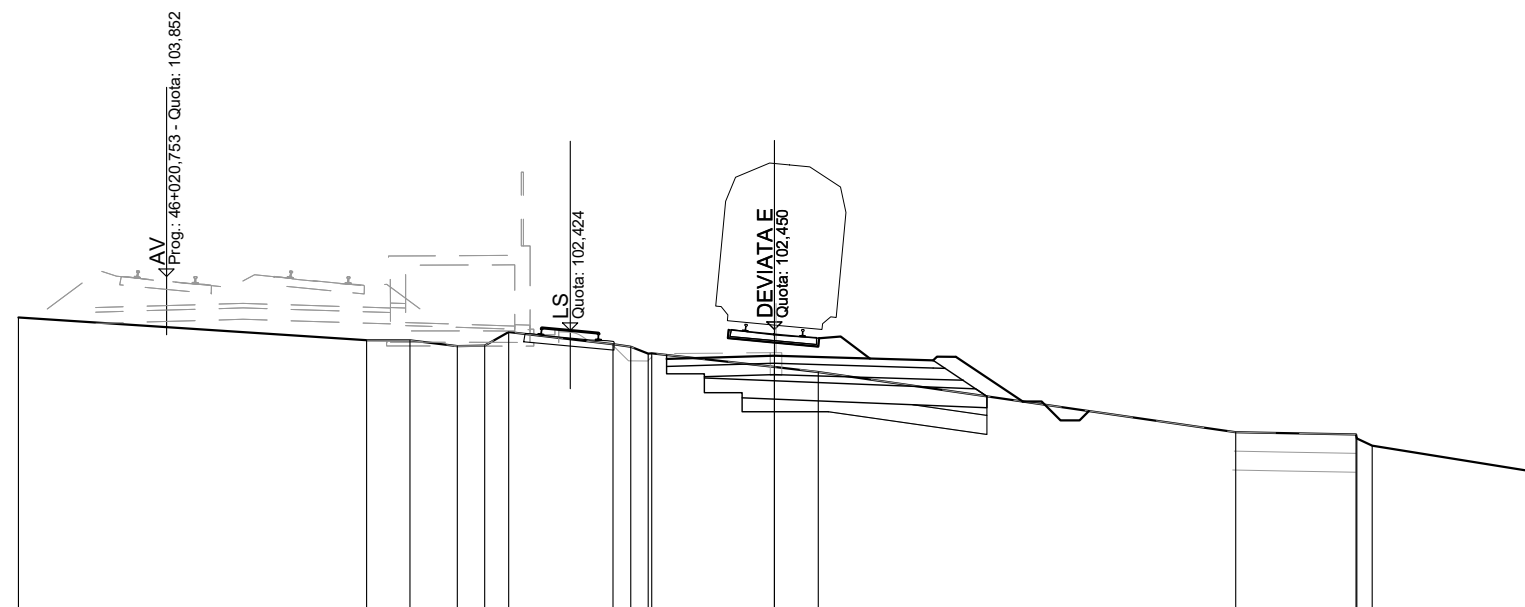

PARZIALI TERRENO		9,210	1,146	1,256	0,723	0,635	2,761	0,930	3,246	1,162	11,045	3,181	4,184										
QUOTE TERRENO	-102,768	-102,166	-102,164	-102,010	-102,022	-102,384	-102,062	-101,811	-101,821	-101,461	-101,326	-99,733	-99,673	-99,379	-98,704								
QUOTA RILEVATO									102,593	102,221	102,584	102,328	102,260	102,216	102,263	101,682	101,632	101,727	100,546	100,046	100,293		
PARZIALI RILEVATO									1,233	0,535	0,506	0,708	0,683	0,510	0,575	0,774	1,671	0,600	1,771	0,500	0,500	0,747	
PARZIALI SUBBALLAST/MISTO																							
QUOTA SUBBALLAST/MISTO									-101,672	-0,000								-101,632	-7,100				

SCAVI E BONIFICHE	
SCOTICO RILEVATO	- m
SCOTICO	0,896 m
BONIFICA	0,896 m
FOSSO	0,508 m <sup>2</sup>
GRADONATURA	7,040 m
RILEVATI	
ANTICAPILLARE	1,801 m <sup>2</sup>
GEOTESSILE	8,259 m
RILEVATO	4,751 m <sup>2</sup>
TERRENO VEGETALE	4,229 m
SOVRASTRUTTURA FERROVIARIA	
SUPERCOMPATTATO 30CM	7,969 m
MISTO STABILIZZATO 20CM	7,593 m
PIATTAFORMA CORPO FERROVIARIO	7,781 m

SEZIONE N.: 23  
 QT. PROGETTO: 102,433  
 DIST.PROG.: 46050,000  
 DIST.PREC.: 25,000  
 DIST.SUCC.: 25,000

SCALA 1:200

QT.RIF. 94,000

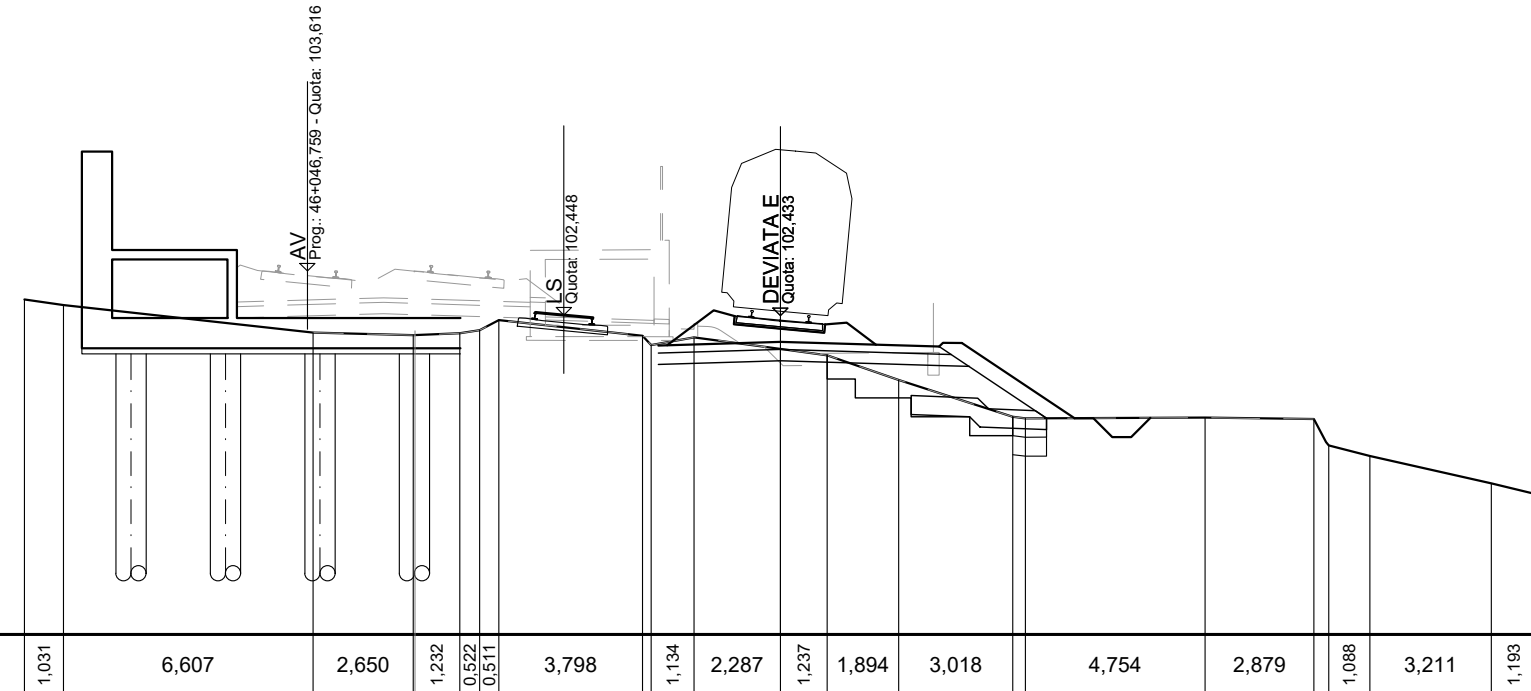

PARZIALI TERRENO	1,031	6,607	2,650	1,232	0,522	0,511	3,798	1,134	2,287	1,237	1,894	3,018	4,754	2,879	1,088	3,211	1,193						
QUOTE TERRENO	-102,861	-102,715	-101,987	-101,917	-101,967	-102,048	-102,314	-101,900	-101,655	-101,859	-101,555	-101,386	-100,731	-99,758	-99,717	-99,737	-99,698	-99,000	-98,720	-98,000	-97,711		
QUOTA RILEVATO								101,651	102,576	102,204	102,567	102,312	102,244	102,200	102,246	101,665	101,615	101,710	99,723	99,723	99,223	99,223	99,731
PARZIALI RILEVATO								1,233	0,535	0,506	0,708	0,683	0,575	0,774	1,671	0,600	2,980	0,500	0,500	0,500	0,508		
PARZIALI SUBBALLAST/MISTO								-0,000								-7,430							
QUOTA SUBBALLAST/MISTO								-101,645								-101,615							



SCAVI E BONIFICHE	
SCOTICO RILEVATO	- m
SCOTICO	1,039 m
BONIFICA	3,176 m
FOSSO	0,105 m <sup>2</sup>
GRADONATURA	6,178 m
RILEVATI	
ANTICAPILLARE	2,491 m <sup>2</sup>
GEOTESSILE	10,966 m
RILEVATO	5,690 m <sup>2</sup>
TERRENO VEGETALE	5,493 m
SOVRASTRUTTURA FERROVIARIA	
SUPERCOMPATTATO 30CM	8,273 m
MISTO STABILIZZATO 20CM	7,883 m
PIATTAFORMA CORPO FERROVIARIO	7,883 m

SEZIONE N.: 24  
 QT. PROGETTO: 102,417  
 DIST.PROG.: 46075,000  
 DIST.PREC.: 25,000  
 DIST.SUCC.: 25,000

SCALA 1:200

QT.RIF. 93,500

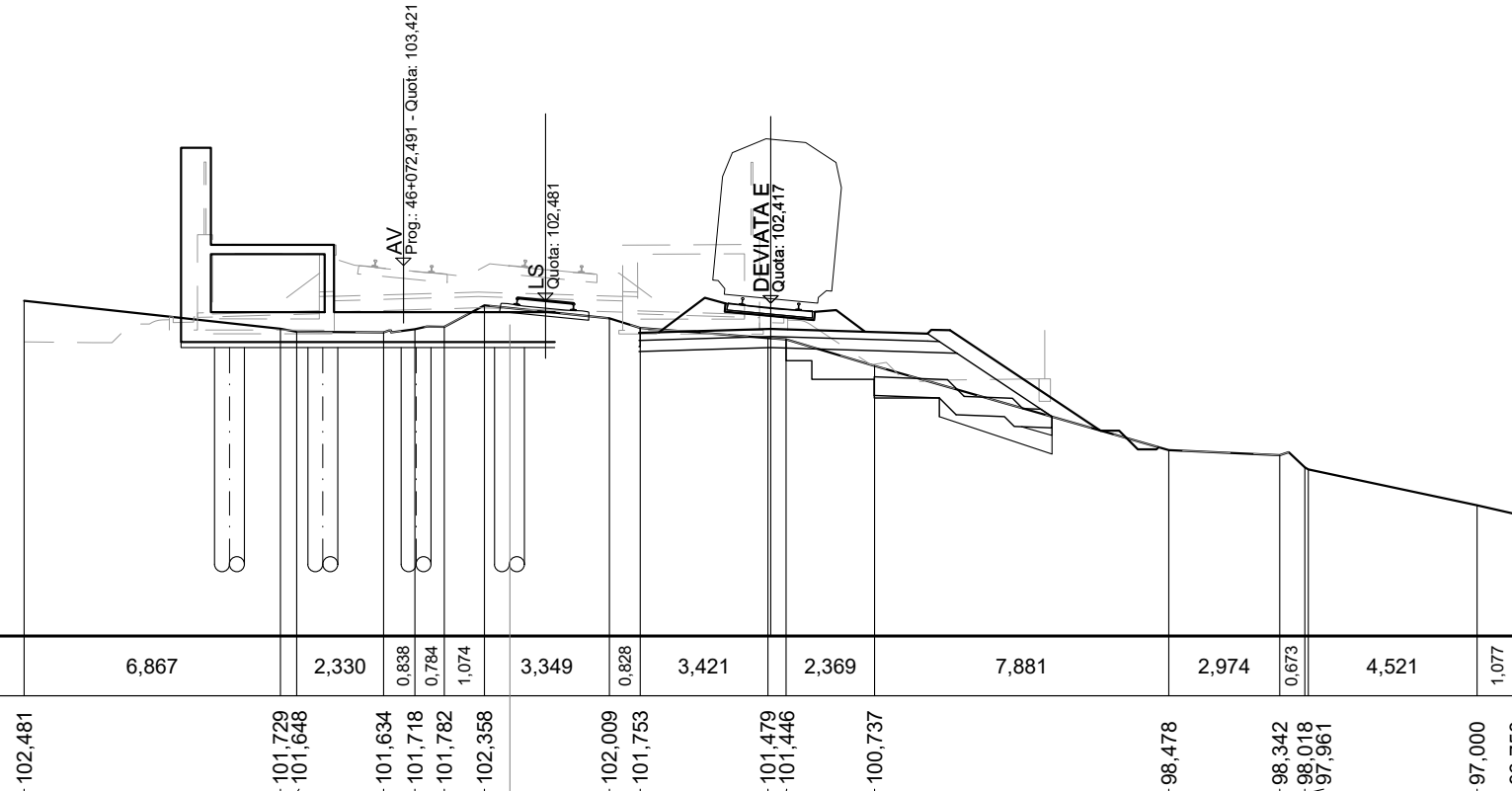

PARZIALI TERRENO		6,867	2,330	0,838	0,784	1,074	3,349	0,828	3,421	2,369	7,881	2,974	0,673	4,521	1,077
QUOTE TERRENO		-102,481	-101,729 -101,648	-101,634	-101,718	-101,782	-102,358	-102,009 -101,753	-101,479 -101,446	-100,737	-98,478	-98,342 -98,018 -97,961	-97,000 -96,758		
QUOTA RILEVATO								101,598 101,635	102,559 102,188 102,550	102,295 102,227 102,183 102,229	101,649	101,598 101,693	99,002 99,002	98,502 98,556	
PARZIALI RILEVATO								1,202	1,233 0,535 0,506 0,708	0,683 0,510 0,575 0,774	1,671 0,600	4,036	0,500 0,500		
PARZIALI SUBBALLAST/MISTO								-0,000			-7,730				
QUOTA SUBBALLAST/MISTO								-102,618			-101,598				

SCAVI E BONIFICHE	
SCOTICO RILEVATO	- m
SCOTICO	1,052 m
BONIFICA	1,335 m
FOSSO	0,108 m <sup>2</sup>
GRADONATURA	7,651 m
RILEVATI	
ANTICAPILLARE	1,540 m <sup>2</sup>
GEOTESSILE	7,179 m
RILEVATO	3,038 m <sup>2</sup>
TERRENO VEGETALE	4,210 m
SOVRASTRUTTURA FERROVIARIA	
SUPERCOMPATTATO 30CM	8,630 m
MISTO STABILIZZATO 20CM	8,205 m
PIATTAFORMA CORPO FERROVIARIO	8,205 m

SEZIONE N.: 25  
 QT. PROGETTO: 102,421  
 DIST.PROG.: 46100,000  
 DIST.PREC.: 25,000  
 DIST.SUCC.: 25,000

SCALA 1:200

QT.RIF. 93,500

PARZIALI TERRENO		6,333	0,620	1,798	1,507	1,401	3,063	0,516	2,441	1,482	14,334	3,223	2,443																
QUOTE TERRENO	-101,780	-101,208	-101,388	-101,210	-101,373	-101,566	-102,363	-102,065	-102,120	-102,245	-102,040	-101,947	-101,920	-97,856	-97,760	-96,994													
QUOTA RILEVATO											102,563	102,192	102,555	102,299	102,231	102,187	102,234	101,653	1,671	101,603	101,698	2,969	99,718	99,718	99,218	99,276			
PARZIALI RILEVATO											0,535	0,506	0,708	0,684	0,510	0,575	0,774												
PARZIALI SUBBALLAST/MISTO																													
QUOTA SUBBALLAST/MISTO																													

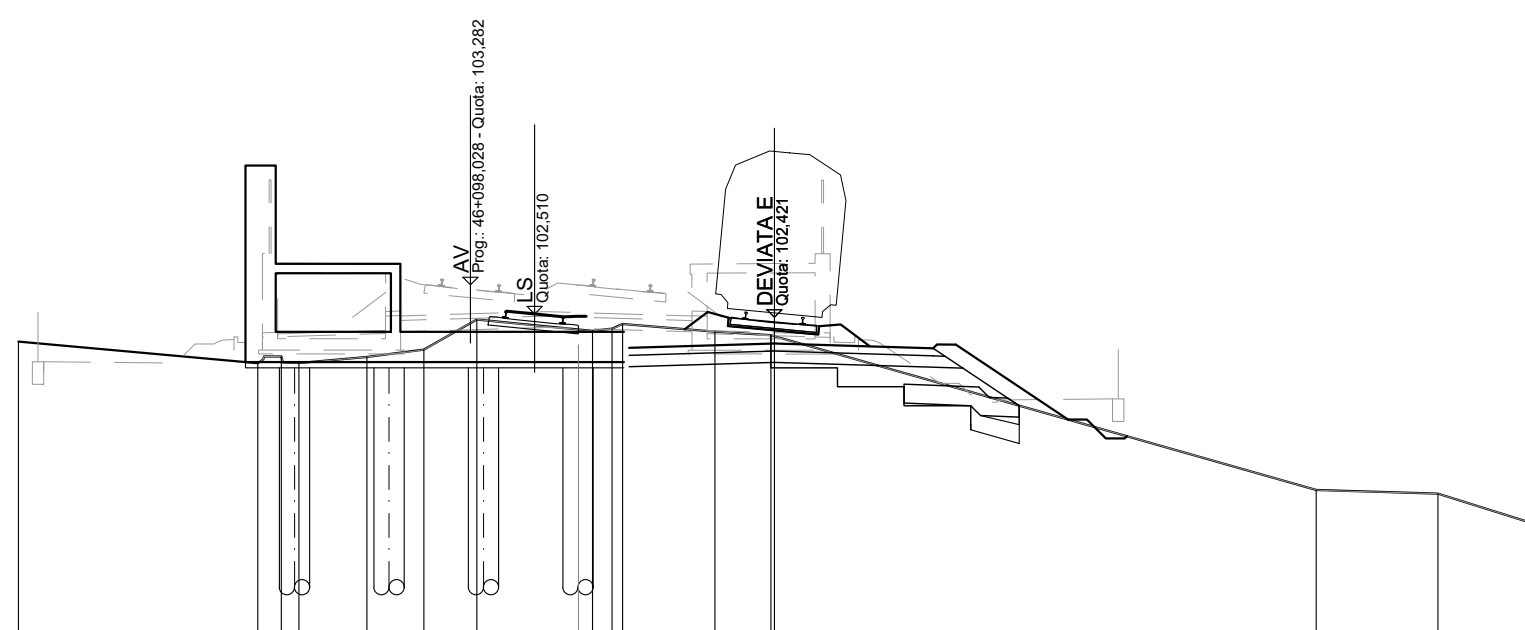





SCAVI E BONIFICHE	
SCOTICO RILEVATO	- m
SCOTICO	2,898 m
BONIFICA	1,615 m
FOSSO	0,178 m <sup>2</sup>
GRADONATURA	3,748 m
RILEVATI	
ANTICAPILLARE	- m <sup>2</sup>
GEOTESSILE	- m
RILEVATO	2,338 m <sup>2</sup>
TERRENO VEGETALE	2,583 m
SOVRASTRUTTURA FERROVIARIA	
SUPERCOMPATTATO 30CM	9,327 m
MISTO STABILIZZATO 20CM	8,713 m
PIATTAFORMA CORPO FERROVIARIO	8,713 m

SEZIONE N.: 28  
 QT. PROGETTO: 102,914  
 DIST.PROG.: 46175,000  
 DIST.PREC.: 25,000  
 DIST.SUCC.: 25,000

SCALA 1:200

QT.RIF. 94,000

PARZIALI TERRENO		6,547	0,788	0,718	0,901	1,672	3,109	1,008	3,286	1,971	0,937	19,063													
QUOTE TERRENO		-101,380	-101,087	-101,628	-101,599	-101,719	-102,460	-102,368	-101,795	-102,446	-102,343	-102,299	-98,165												
QUOTA RILEVATO										102,138	102,953	102,604	102,982	102,761	102,722	102,478	102,768	102,146	102,098	102,193	101,108	101,108	100,608	100,752	
PARZIALI RILEVATO										1,087	0,550	0,501	0,708	0,886	0,500	0,572	0,829	1,610	0,600	1,626	0,500	0,500	0,643		
PARZIALI SUBBALLAST/MISTO									-0,000											-7,813					
QUOTA SUBBALLAST/MISTO									-102,115											-102,098					

LS - Quota: 102,759  
 AV - Prog.: 46+174,094 - Quota: 103,190

DEVIATE  
 Quota: 102,914

SCAVI E BONIFICHE	
SCOTICO RILEVATO	- m
SCOTICO	1,743 m
BONIFICA	2,575 m
FOSSO	0,236 m <sup>2</sup>
GRADONATURA	4,394 m
RILEVATI	
ANTICAPILLARE	2,070 m <sup>2</sup>
GEOTESSILE	9,783 m
RILEVATO	4,193 m <sup>2</sup>
TERRENO VEGETALE	3,481 m
SOVRASTRUTTURA FERROVIARIA	
SUPERCOMPATTATO 30CM	9,278 m
MISTO STABILIZZATO 20CM	8,780 m
PIATTAFORMA CORPO FERROVIARIO	8,780 m

SEZIONE N.: 29  
 QT. PROGETTO: 103,115  
 DIST.PROG.: 46200,000  
 DIST.PREC.: 25,000  
 DIST.SUCC.: 25,000

SCALA 1:200

QT.RIF. 95,000

PARZIALI TERRENO		5,876	0,640	0,783	0,700	1,171	3,082	1,243	0,628	4,656	0,715	9,452	10,548		
QUOTE TERRENO		-101,690	-101,451	-101,889	-101,884	-101,886	-102,346	-102,671	-102,581	-102,085	-102,069	-102,148	-102,027	-100,433	-99,066
QUOTA RILEVATO															
PARZIALI RILEVATO															
PARZIALI SUBBALLAST/MISTO															
QUOTA SUBBALLAST/MISTO															

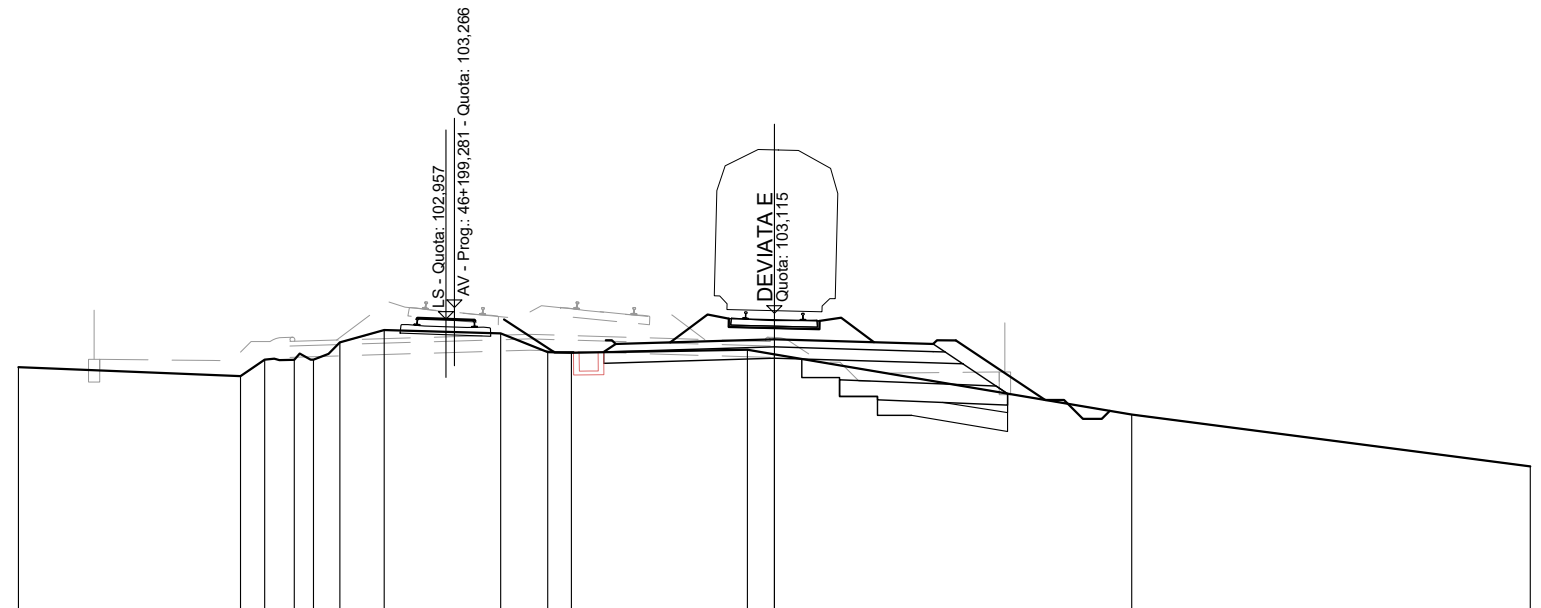

I.S. - Quota: 102,957  
 AV - Prog.: 46+199,281 - Quota: 103,266

DEVIATORE  
 Quota: 103,115

SCAVI E BONIFICHE	
SCOTICO RILEVATO	- m
SCOTICO	2,244 m
BONIFICA	4,099 m
FOSSO	0,286 m <sup>2</sup>
GRADONATURA	2,759 m
RILEVATI	
ANTICAPILLARE	2,556 m <sup>2</sup>
GEOTESSILE	12,127 m
RILEVATO	4,012 m <sup>2</sup>
TERRENO VEGETALE	3,062 m
SOVRASTRUTTURA FERROVIARIA	
SUPERCOMPATTATO 30CM	8,956 m
MISTO STABILIZZATO 20CM	8,618 m
PIATTAFORMA CORPO FERROVIARIO	8,618 m

SEZIONE N.: 30  
 QT. PROGETTO: 103,317  
 DIST.PROG.: 46225,000  
 DIST.PREC.: 25,000  
 DIST.SUCC.: 25,000

SCALA 1:200

QT.RIF. 95,000

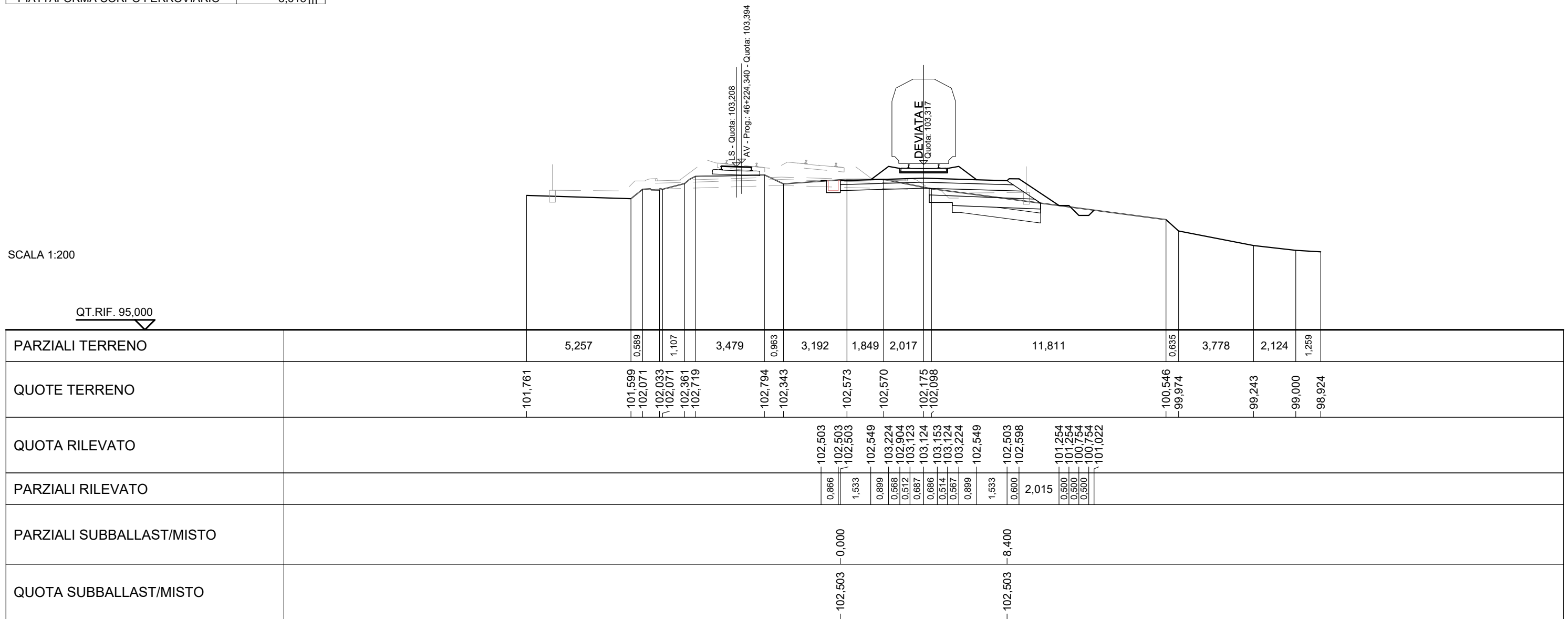









SCAVI E BONIFICHE	
SCOTICO RILEVATO	- m
SCOTICO	- m
BONIFICA	- m
FOSSO	0,523 m <sup>2</sup>
RILEVATI	
ANTICAPILLARE	- m <sup>2</sup>
GEOTESSILE	- m
RILEVATO	- m <sup>2</sup>
TERRENO VEGETALE	- m
SOVRASTRUTTURA FERROVIARIA	
SUPERCOMPATTATO 30CM	8,622 m
MISTO STABILIZZATO 20CM	8,624 m
PIATTAFORMA CORPO FERROVIARIO	8,624 m

SEZIONE N.: 34  
 QT. PROGETTO: 104,390  
 DIST.PROG.: 46325,000  
 DIST.PREC.: 25,000  
 DIST.SUCC.: 25,000

SCALA 1:200

QT.RIF. 94,500

PARZIALI TERRENO	1,436	1,817	0,984	0,501	0,508	0,703	0,766	0,798	0,626	0,872	1,443	3,044	1,472	4,630	0,620	0,883	1,020	0,500	0,500	0,651	0,600	5,061	10,153		
QUOTE TERRENO	-104,173	-104,000	-104,926	-104,901	-104,779	-104,780	-104,250	-104,231	-103,242	-103,208	-102,572	-103,286	-104,038	-103,901	-103,441	-103,347	-103,334	-103,360	-103,309	-104,810	-104,260	-104,260	-104,811	-104,459	-103,640
QUOTA RILEVATO														103,575	103,620	104,334	104,006	104,217	104,208	104,226	103,970	104,282	103,622	103,575	
PARZIALI RILEVATO														1,479	0,952	0,563	0,515	0,687	0,885	0,510	0,571	0,879	1,555		
PARZIALI SUBBALLAST/MISTO																									
QUOTA SUBBALLAST/MISTO																									

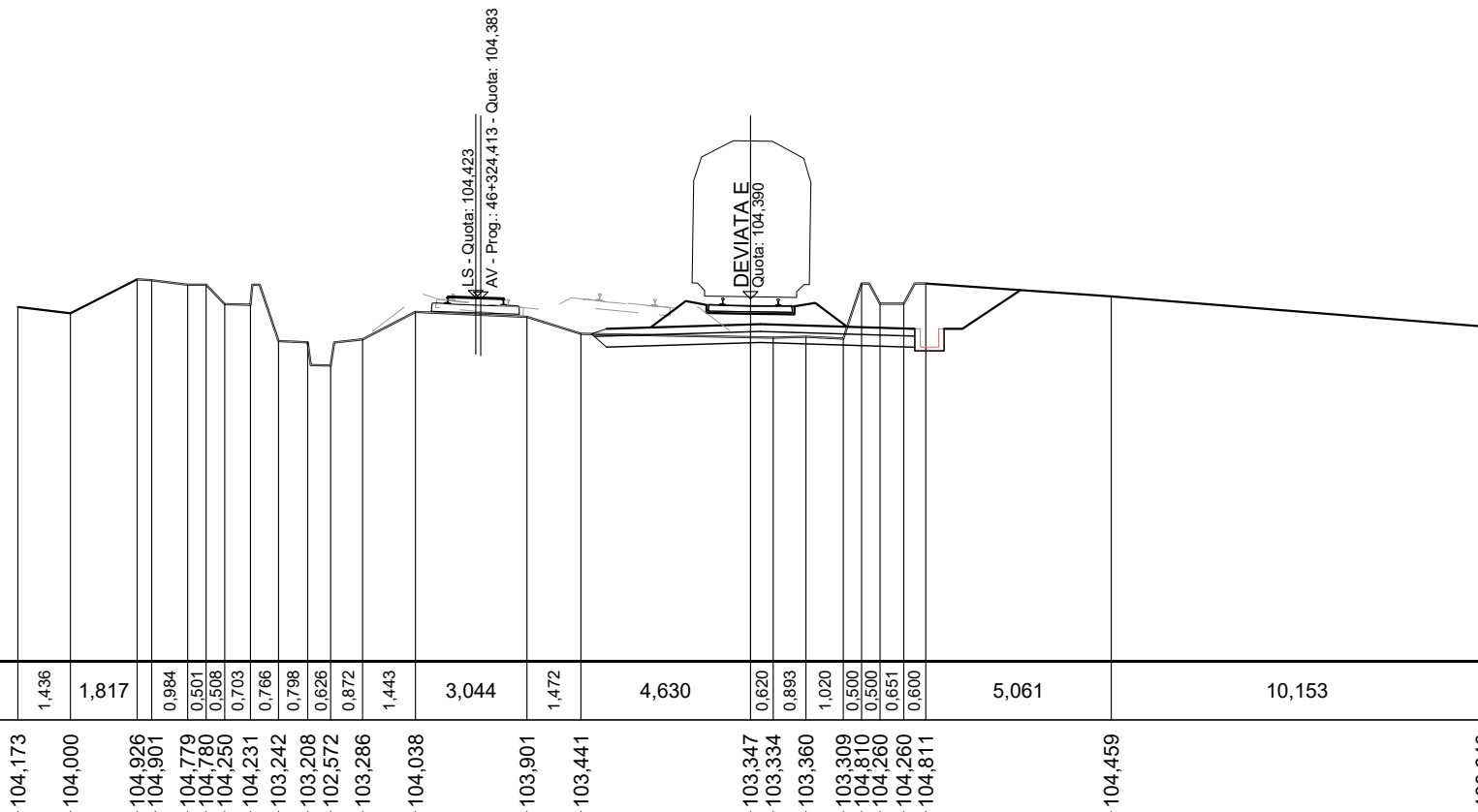

SCAVI E BONIFICHE		
SCOTICO RILEVATO	-	m
SCOTICO	-	m
BONIFICA	-	m
RILEVATI		
ANTICAPILLARE	-	m <sup>2</sup>
GEOTESSILE	-	m <sup>2</sup>
RILEVATO	-	m <sup>2</sup>
TERRENO VEGETALE	-	m
SOVRASTRUTTURA FERROVIARIA		
SUPERCOMPATTATO 30CM	7,435	m
MISTO STABILIZZATO 20CM	7,435	m
PIATTAFORMA CORPO FERROVIARIO	7,435	m

SEZIONE N.: 35  
 QT. PROGETTO: 104,684  
 DIST.PROG.: 46350,000  
 DIST.PREC.: 25,000  
 DIST.SUCC.: 25,000

SCALA 1:200

QT.RIF. 93,000

PARZIALI TERRENO	0,924	3,830	0,749	0,599	0,501	0,649	0,520	0,488	0,812	0,782	0,600	0,937	1,205	2,982	0,495	0,728	3,476	1,983	1,831	1,164	0,509	2,177	3,090	3,180	5,573				
QUOTE TERRENO	-105,001	-105,002	-104,714	-104,988	-104,984	-104,984	-104,495	-104,488	-103,488	-103,485	-102,908	-103,562	-103,753	-104,330	-104,268	-104,017	-103,699	-103,689	-103,690	-103,597	-104,373	-103,288	-102,875	-102,000	-101,879	-100,949	-100,930	-99,235	
QUOTA RILEVATO															103,869	103,912	104,666	104,329	104,532	104,514	104,521	104,258	104,562	103,917	103,869				
PARZIALI RILEVATO															1,426	1,004	0,558	0,518	0,687	0,686	0,506	0,576	0,860	1,576					
PARZIALI SUBBALLAST/MISTO																													
QUOTA SUBBALLAST/MISTO																													

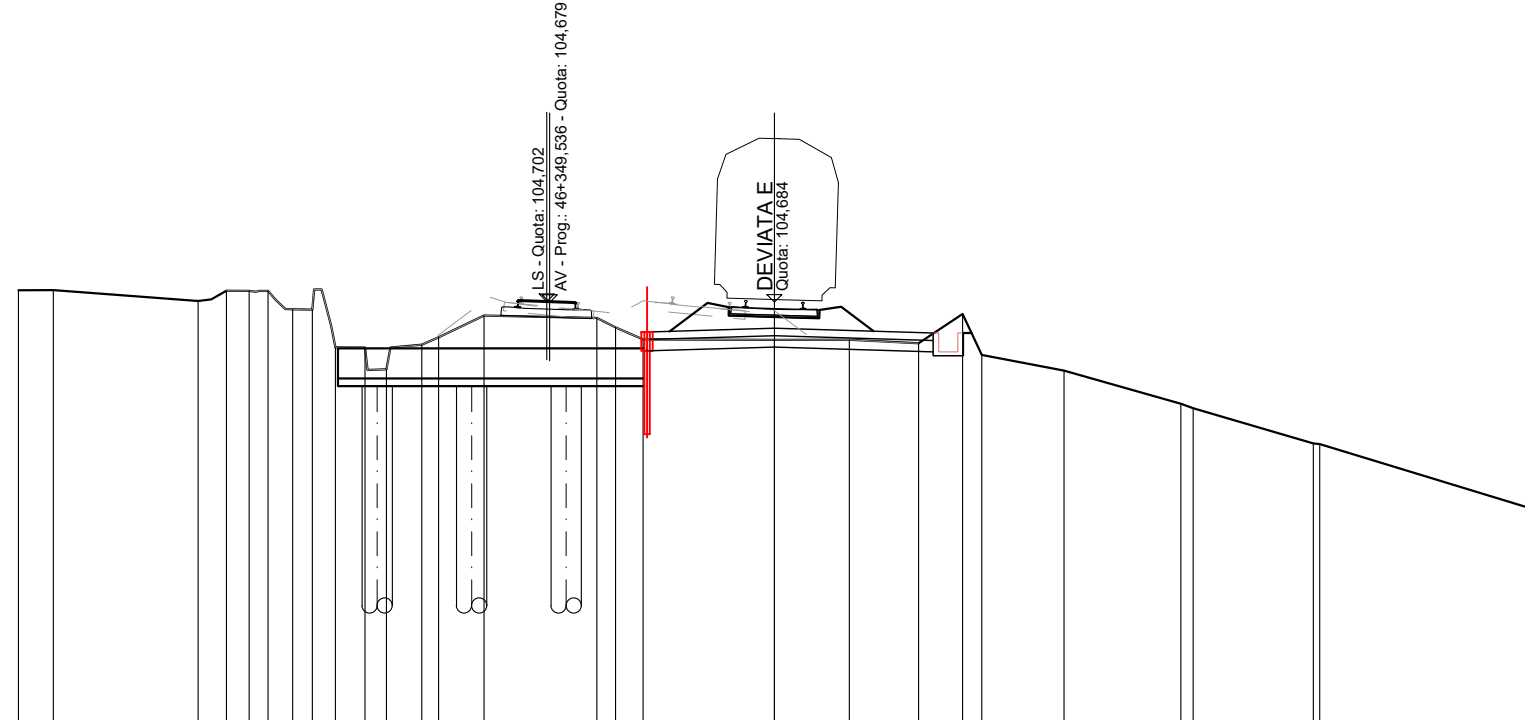

SCAVI E BONIFICHE		
SCOTICO RILEVATO	-	m
SCOTICO	-	m
BONIFICA	-	m
RILEVATI		
ANTICAPILLARE	-	m <sup>2</sup>
GEOTESSILE	-	m
RILEVATO	-	m <sup>2</sup>
TERRENO VEGETALE	-	m
SOVRASTRUTTURA FERROVIARIA		
SUPERCOMPATTATO 30CM	6,615	m
MISTO STABILIZZATO 20CM	6,555	m
PIATTAFORMA CORPO FERROVIARIO	6,555	m

SEZIONE N.: 36  
 QT. PROGETTO: 104,979  
 DIST.PROG.: 46375,000  
 DIST.PREC.: 25,000  
 DIST.SUCC.: 25,000

SCALA 1:200

QT.RIF. 95,000

PARZIALI TERRENO	0,877	1,828	2,568	1,435	0,953	0,763	0,745	0,994	2,438	3,370	1,281	1,815	2,453	1,455	1,158	0,511	0,559	0,573	1,487	1,748	1,980	4,887	0,644	1,506	0,546	0,493		
QUOTE TERRENO	-106,290	-106,312	-106,217	-105,614	-105,000	-104,775	-106,466	-108,630	-108,925	-104,548	-104,754	-104,733	-104,669	-104,092	-104,093	-104,041	-104,039	-104,205	-105,282	-103,662	-103,000	-103,000	-102,905	-103,311	-103,323	-103,278	-103,231	-103,148
QUOTA RILEVATO												104,163	104,205	104,997	104,652	104,848	104,819	104,817	104,547	104,842	104,211	104,163						
PARZIALI RILEVATO												1,374	1,056	0,553	0,521	0,687	0,686	0,503	0,580	0,840	1,597							
PARZIALI SUBBALLAST/MISTO																												
QUOTA SUBBALLAST/MISTO																												

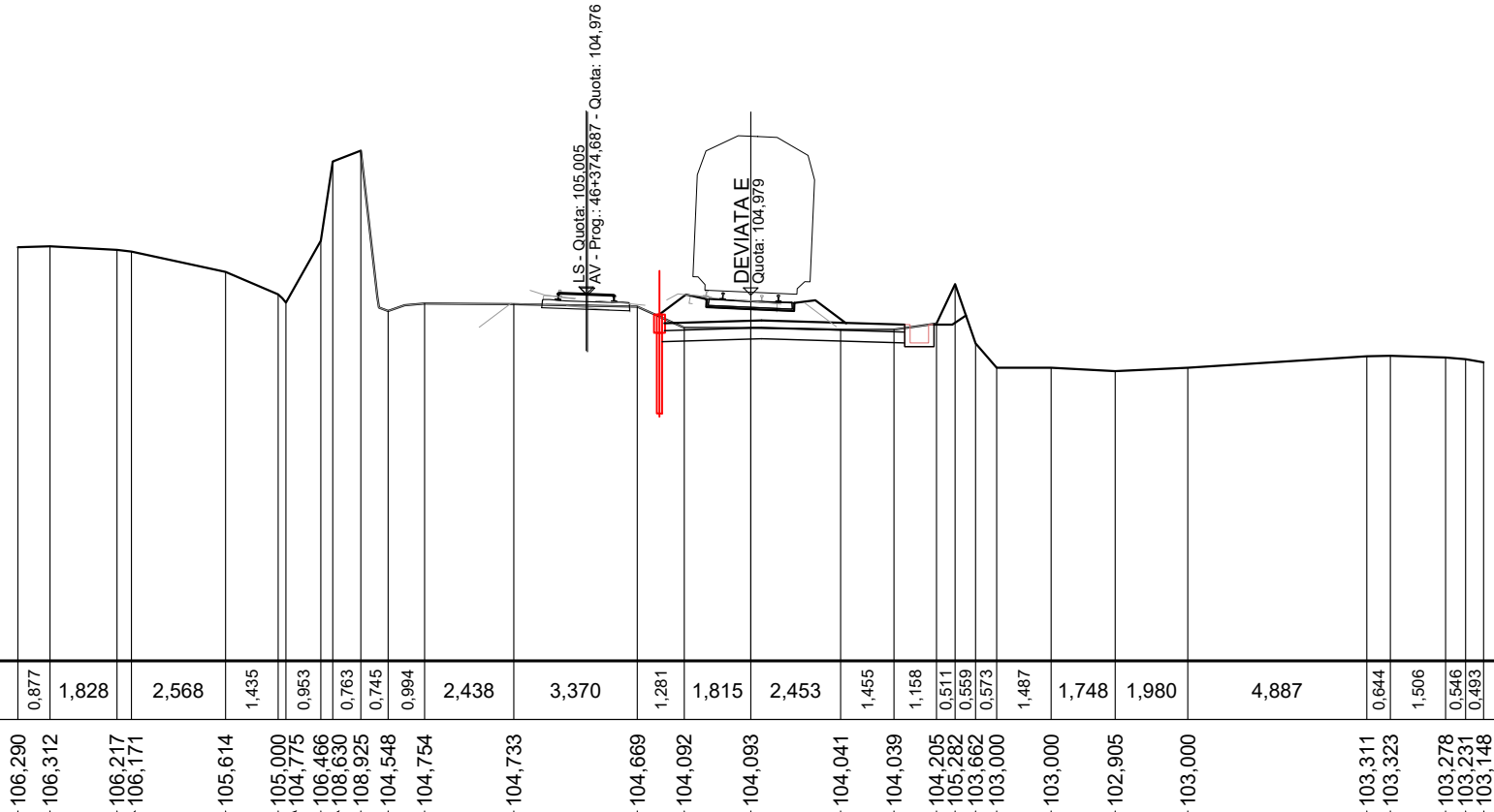

SEZIONE N.: 37  
 QT. PROGETTO: 105,274  
 DIST.PROG.: 46400,000  
 DIST.PREC.: 25,000  
 DIST.SUCC.: 25,000

SCALA 1:200

QT.RIF. 98,000

PARZIALI TERRENO	0,632	1,930	1,884	2,916	1,710	0,988	0,544	0,504	0,668	1,315	1,338	3,483	1,320	1,394	1,553	1,165	3,367	1,824	1,302	1,331	3,525	3,649								
QUOTE TERRENO	-113,792	-113,766	-113,640	-113,714	-114,000	-114,071	-114,151	-114,237	-113,772	-108,825	-108,381	-105,584	-105,160	-105,157	-105,030	-104,471	-104,472	-104,472	-104,796	-105,154	-105,155	-105,250	-113,000	-112,643	-112,594	-112,000	-111,139	-111,000	-110,053	-109,830
QUOTA RILEVATO												104,458	104,499	105,299	104,953	105,327	105,116	105,112	104,841	105,134	104,506	104,458								
PARZIALI RILEVATO												1,365	1,066	0,552	0,500	0,708	0,886	0,502	0,581	0,837	1,601									
PARZIALI SUBBALLAST/MISTO																														
QUOTA SUBBALLAST/MISTO																														

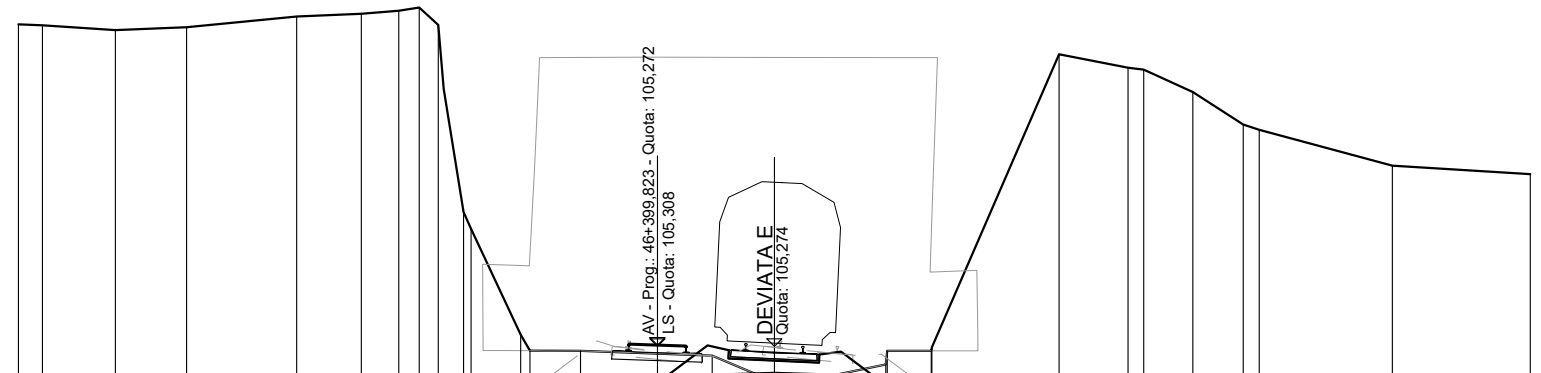



SEZIONE N.: 39  
 QT. PROGETTO: 105,863  
 DIST.PROG.: 46450,000  
 DIST.PREC.: 25,000  
 DIST.SUCC.: 25,000

SCALA 1:200

QT.RIF. 101,500

PARZIALI TERRENO	0,565	2,019	4,284	1,939	3,221	0,979	3,165	0,837	2,991	1,432	1,877	1,171	0,540	0,829	2,619	1,465	4,229	2,654	2,553		
QUOTE TERRENO	-124,113 -124,000	-123,107	-123,174	-123,000	-122,746	-119,444	-109,134	-105,749	-105,635	-105,627	-105,041	-105,077	-105,115	-105,459	-105,788	-108,667	-114,790	-120,715	-120,000	-119,531	-119,101
QUOTA RILEVATO							105,048	105,089	105,888	105,542	105,916	105,706	105,701	105,430	105,723	105,096	105,048				
PARZIALI RILEVATO							1,365	1,066	0,552	0,500	0,708	0,678	0,502	0,581	0,837	1,601					
PARZIALI SUBBALLAST/MISTO																					
QUOTA SUBBALLAST/MISTO																					

AV - Piv. - Quota: 105,863  
 LS - Quota: 105,863  
 DEVIATA E - Quota: 105,863













