

Immagini estratte da
Elaborato 8:
Relazione opere marittime

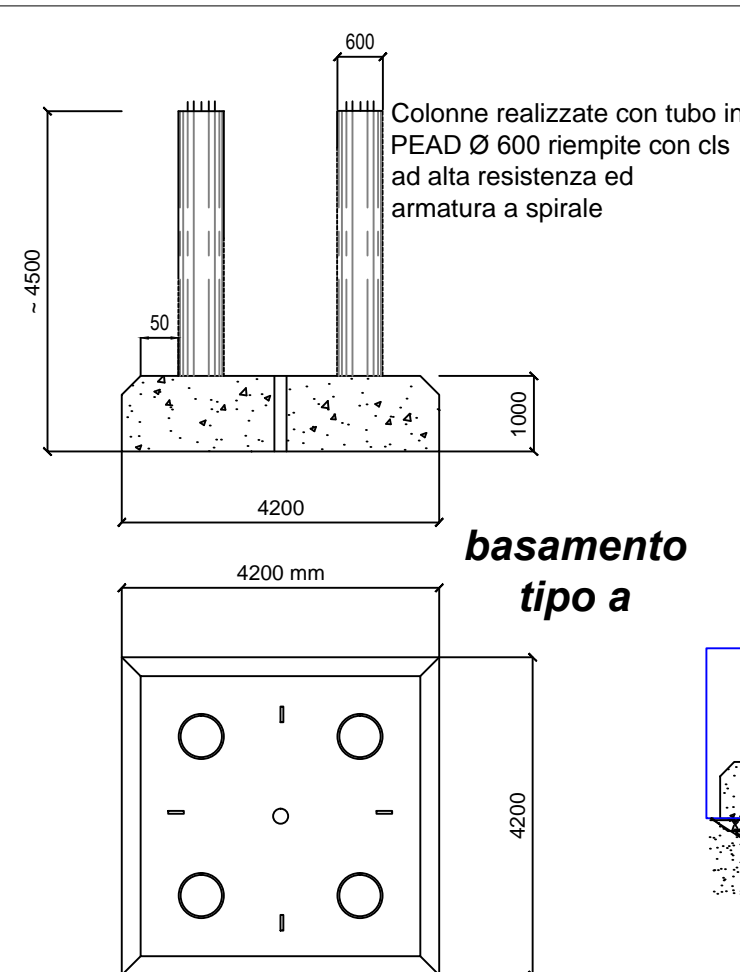

Peso 52 t
Basamento in calcestruzzo debolmente armato (gia' disponibile)

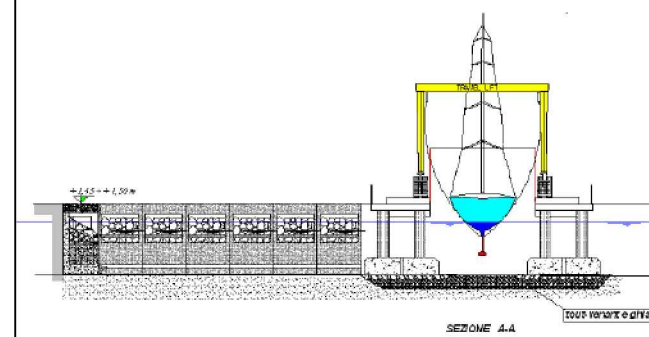
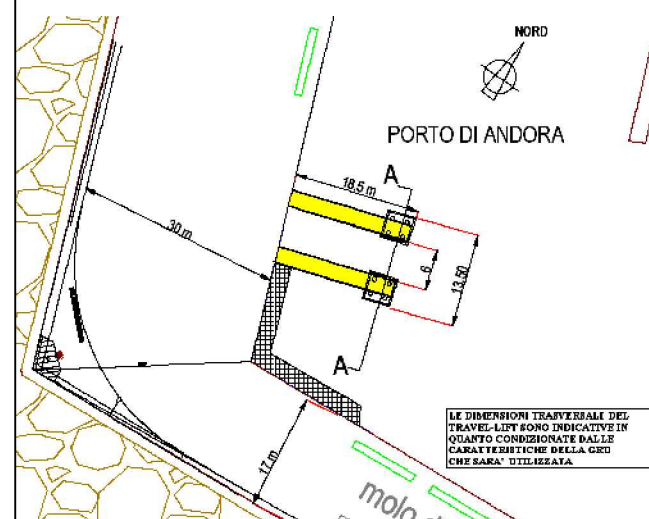
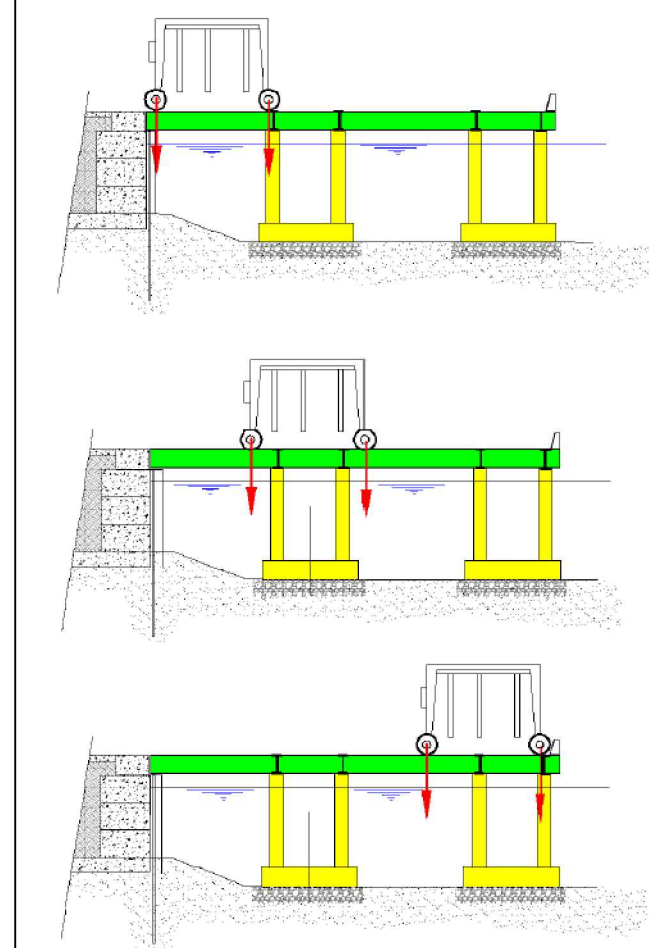
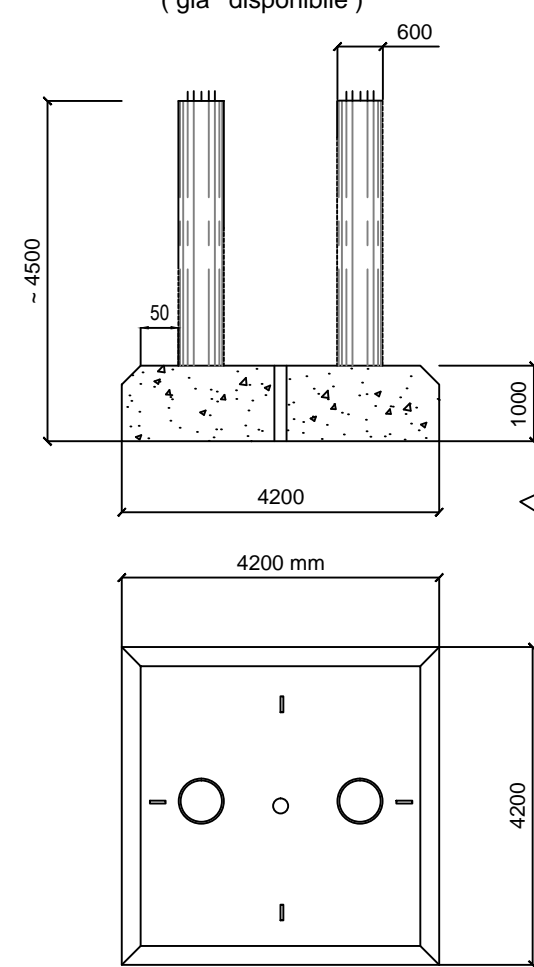

Peso 48 t
Basamento in calcestruzzo debolmente armato (da realizzare)

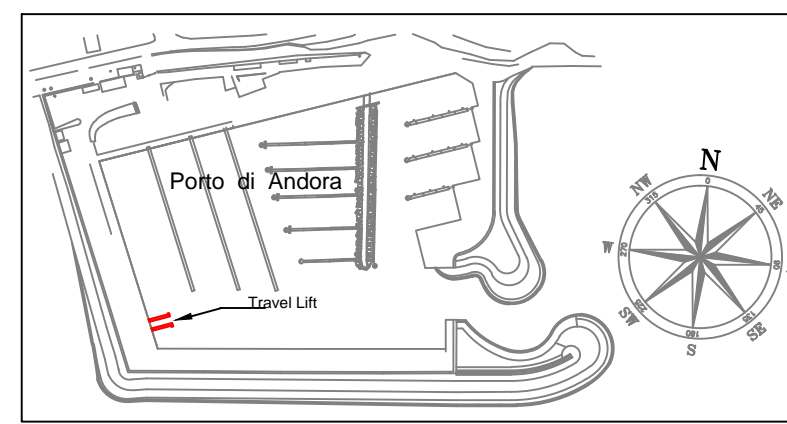
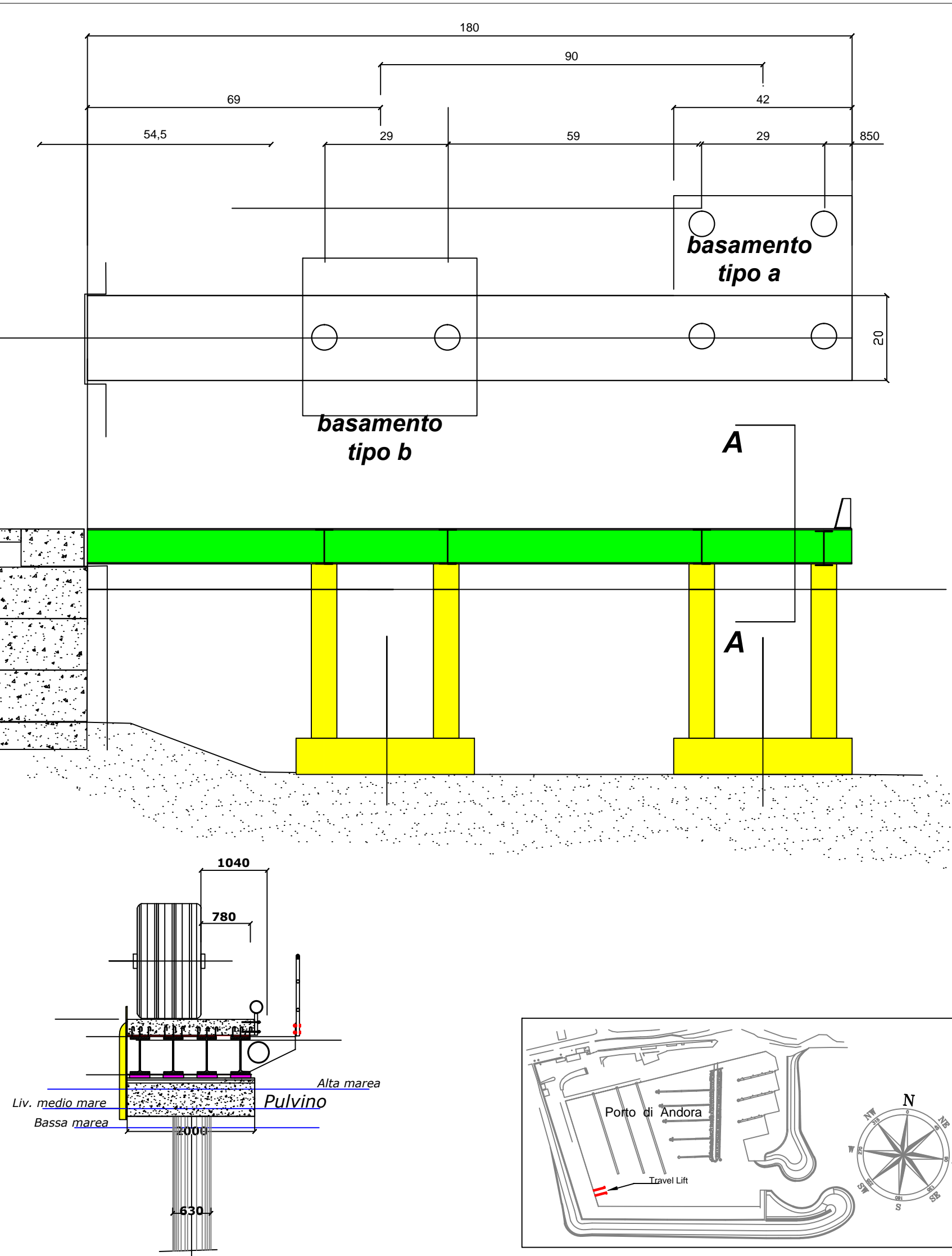
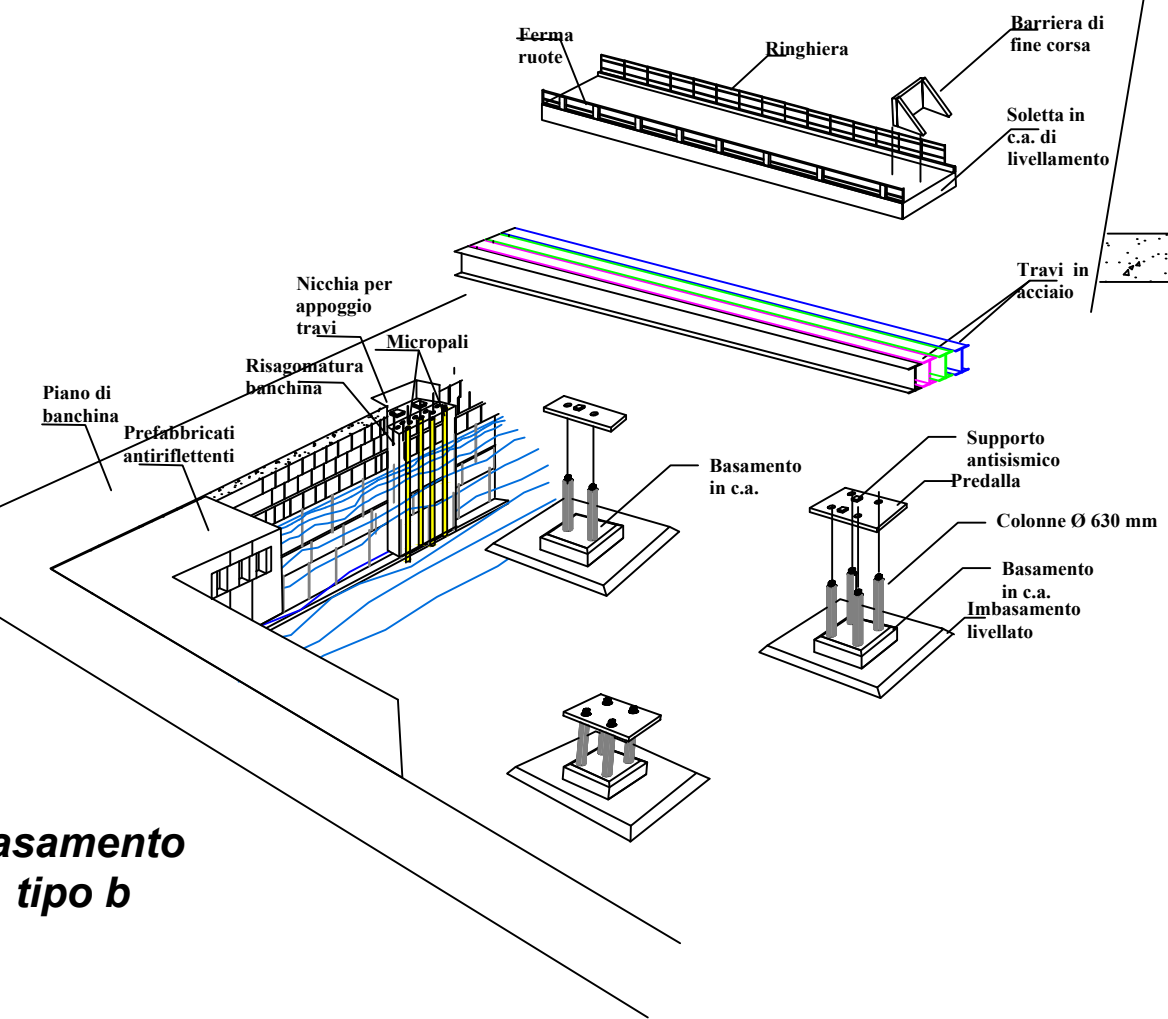
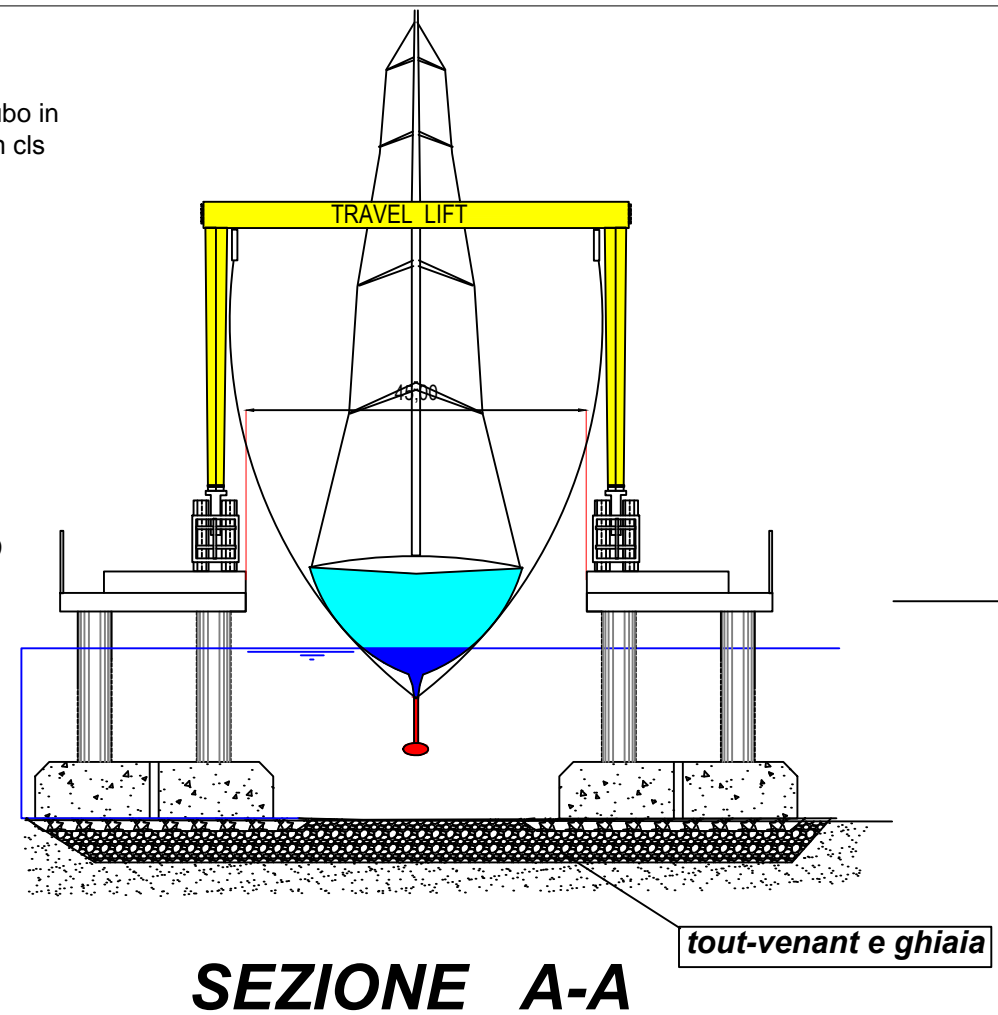

COMUNE DI ANDORA
PROVINCIA DI SAVONA

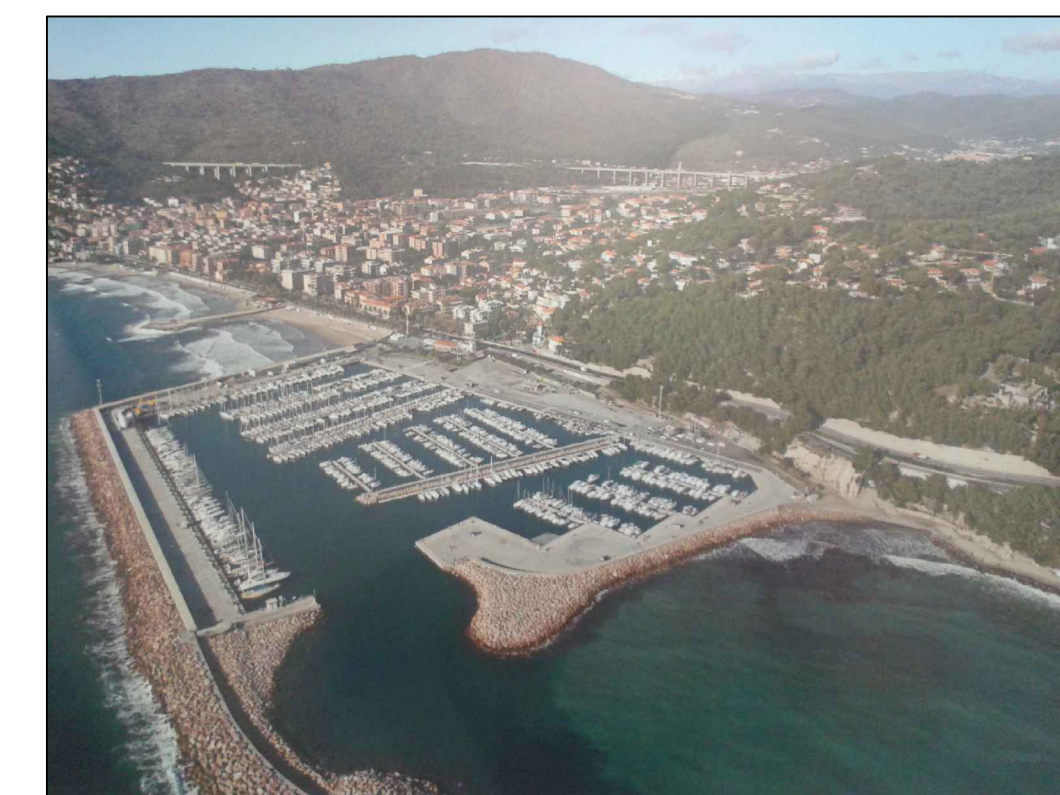

PUO A MODIFICA DELLO S.U.A. APPROVATO CON
PROVVEDIMENTO FINALE IN DATA 16/03/2010 -
DISTRETTO DI TRASFORMAZIONE TR-CO2 IN
AGGIORNAMENTO AL PUC

Oggetto **Travel Lift**

Scala **Varie**

Data **Marzo 2022**

Progettisti Arch. Paolo Ghione Arch. Isabella Rabellino Ing. Alessandro Chini

revisioni	data	note		
1	Marzo 2022			
2				
3				
4				
5				

Tavola

16