

Vertice	X	Y
1	143263.6482	341508.0674
2	143268.5653	341509.9619
3	143269.777	341512.5708
4	143261.102	341537.6183
5	143261.414	341544.471

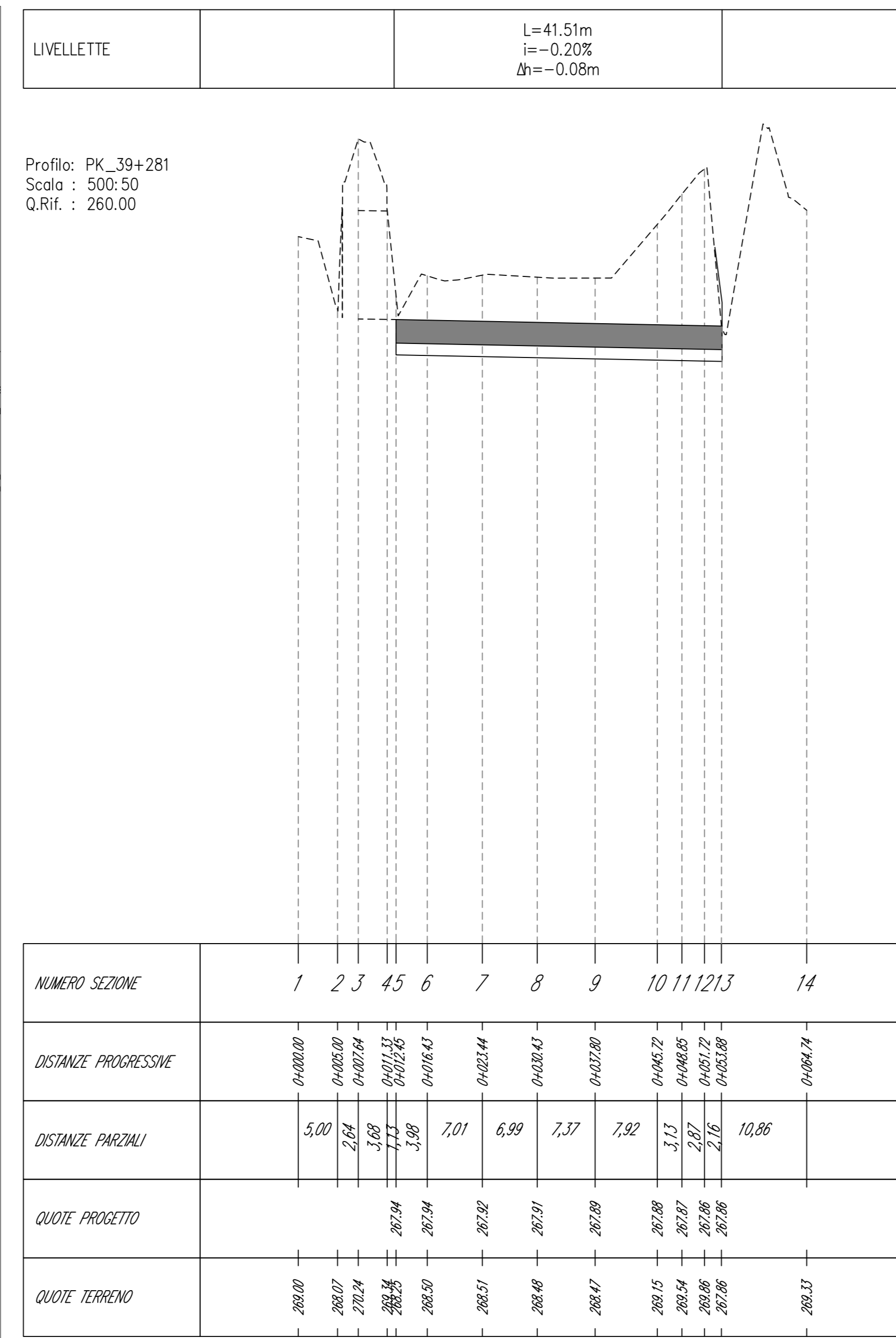

SEZIONE TIPO MATERASSI TIPO RENO
scala 1:20

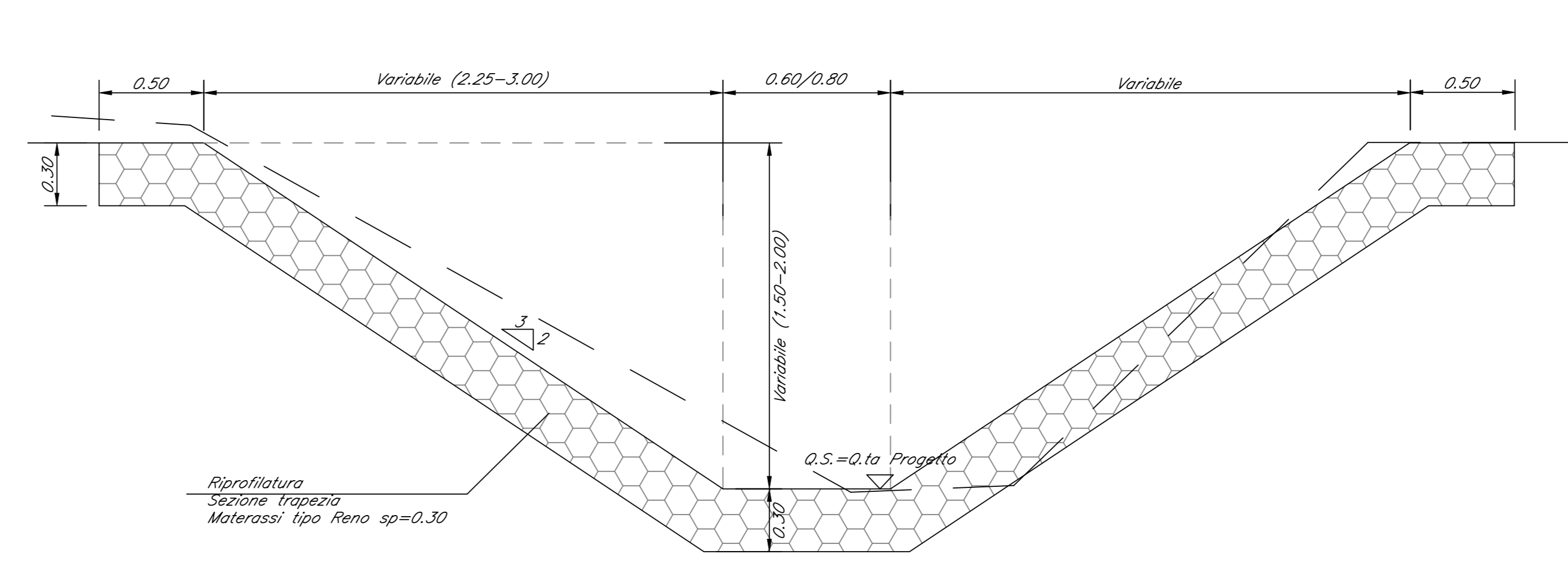

SEZIONE TIPO IN TERRA
scala 1:20

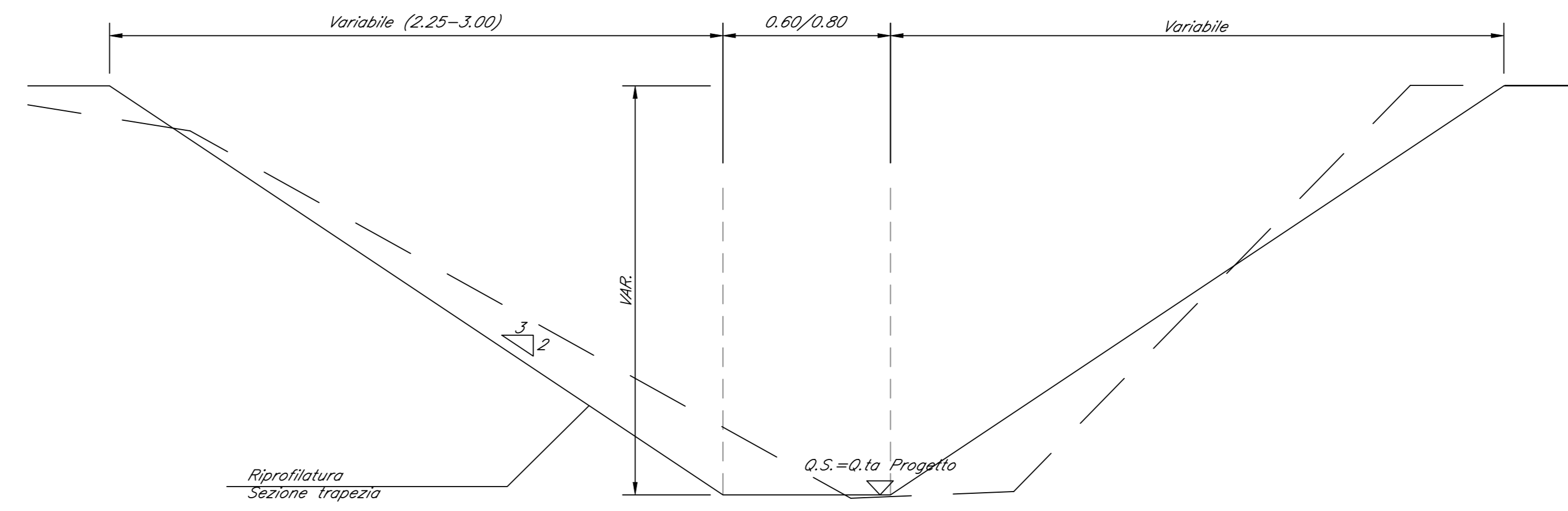

SEZIONE TIPO CANALE RETTANGOLARE
scala 1:20

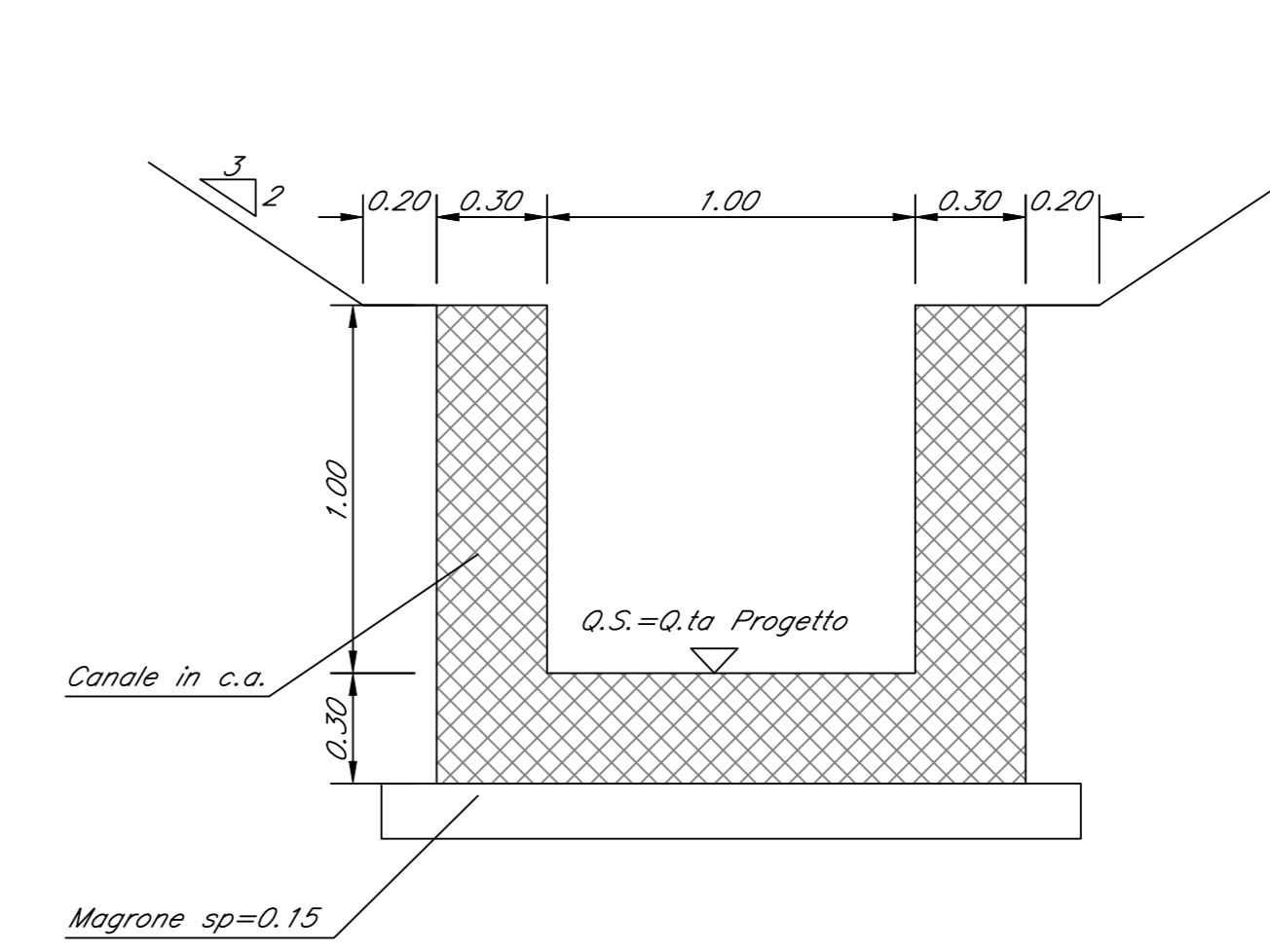

PK_39+281 - Sez. 5 - Progr. 0402.45
Scala 1:100
Q.RIF. 261.00m

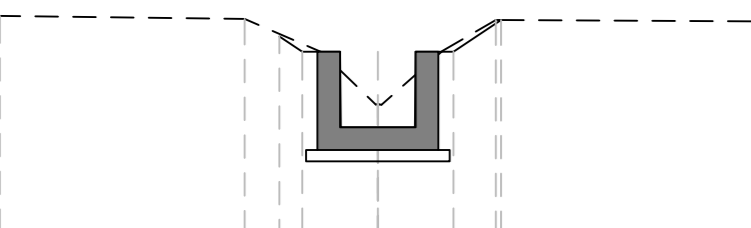

PROGRESSIVE TERRENO	-5.00	-4.63	-3.49	0.00	1.36	5.00
QUOTE TERRENO	286.50	286.57	286.69	286.57	286.51	286.51
DISTANZE PARZIALI TERRENO	1.51	0.97	1.46	1.87	1.16	1.40
PROGRESSIVE PROGETTO	-1.00	-0.80	-0.60	0.00	1.00	1.71
QUOTE PROGETTO	286.51	286.54	286.54	286.54	286.54	286.57
DISTANZE PARZIALI PROGETTO	0.51	0.30	0.30	1.00	0.71	0.00

PK_39+281 - Sez. 7 - Progr. 0402.14
Scala 1:100
Q.RIF. 262.00m

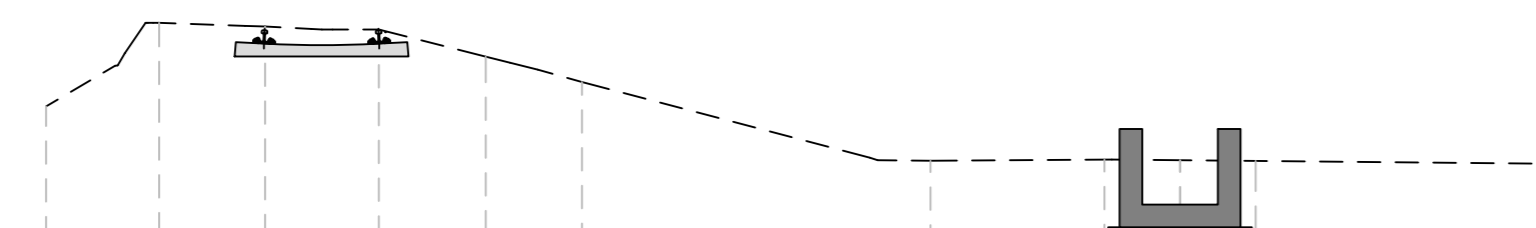

PROGRESSIVE TERRENO	-5.00	-4.65	-3.50	0.00	1.35	5.00
QUOTE TERRENO	286.52	286.78	286.92	286.52	286.50	286.46
DISTANZE PARZIALI TERRENO	1.51	0.97	1.46	1.87	1.16	1.40
PROGRESSIVE PROGETTO	-1.00	-0.80	-0.60	0.00	1.00	1.71
QUOTE PROGETTO	286.52	286.54	286.54	286.54	286.54	286.57
DISTANZE PARZIALI PROGETTO	0.51	0.30	0.30	1.00	0.71	0.00

PK_39+281 - Sez. 9 - Progr. 0402.70
Scala 1:100
Q.RIF. 262.00m

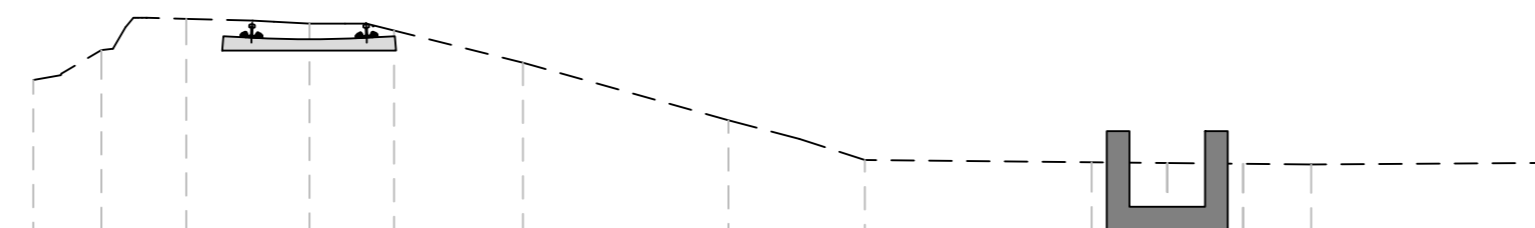

PROGRESSIVE TERRENO	-5.00	-4.62	-3.49	0.00	1.36	5.00
QUOTE TERRENO	286.52	286.78	286.92	286.52	286.50	286.46
DISTANZE PARZIALI TERRENO	1.51	0.97	1.46	1.87	1.16	1.40
PROGRESSIVE PROGETTO	-1.00	-0.80	-0.60	0.00	1.00	1.71
QUOTE PROGETTO	286.49	286.50	286.50	286.50	286.50	286.52
DISTANZE PARZIALI PROGETTO	0.49	0.30	0.30	1.00	0.71	0.00

PK_39+281 - Sez. 11 - Progr. 0408.85
Scala 1:100
Q.RIF. 261.00m

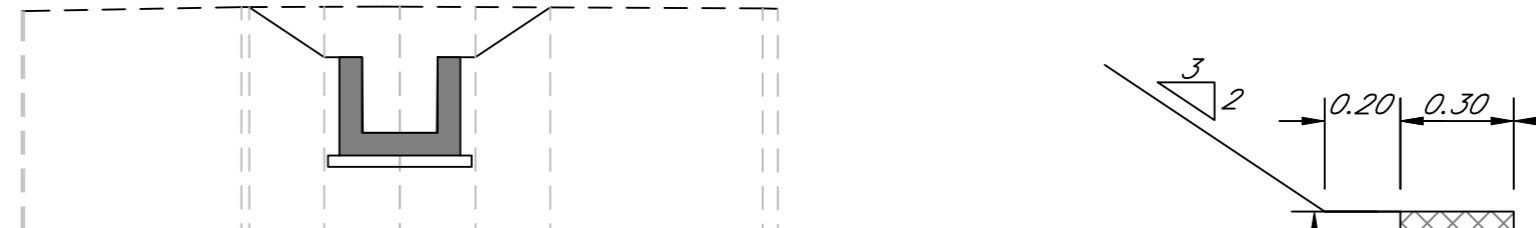

PROGRESSIVE TERRENO	-5.00	-4.57	-3.42	0.00	1.39	5.00
QUOTE TERRENO	286.48	286.67	286.85	286.48	286.45	286.41
DISTANZE PARZIALI TERRENO	1.51	0.96	1.46	1.87	1.15	1.40
PROGRESSIVE PROGETTO	-1.00	-0.80	-0.60	0.00	1.00	1.71
QUOTE PROGETTO	286.57	286.67	286.67	286.67	286.67	286.70
DISTANZE PARZIALI PROGETTO	0.57	0.30	0.30	1.00	0.71	0.00

PK_39+281 - Sez. 6 - Progr. 04016.43
Scala 1:100
Q.RIF. 261.00m

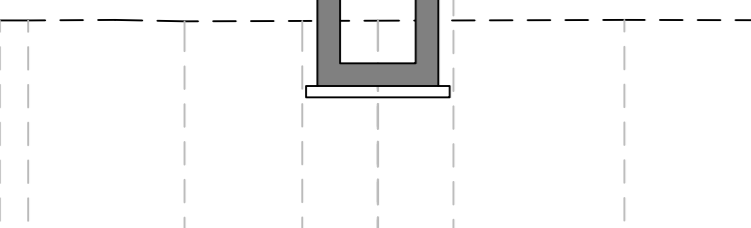

PROGRESSIVE TERRENO	-5.00	-4.63	-3.49	0.00	1.36	5.00
QUOTE TERRENO	286.50	286.57	286.69	286.57	286.51	286.51
DISTANZE PARZIALI TERRENO	1.51	0.97	1.46	1.87	1.16	1.40
PROGRESSIVE PROGETTO	-1.00	-0.80	-0.60	0.00	1.00	1.71
QUOTE PROGETTO	286.50	286.54	286.54	286.54	286.54	286.57
DISTANZE PARZIALI PROGETTO	0.50	0.30	0.30	1.00	0.71	0.00

PK_39+281 - Sez. 8 - Progr. 04020.43
Scala 1:100
Q.RIF. 262.00m

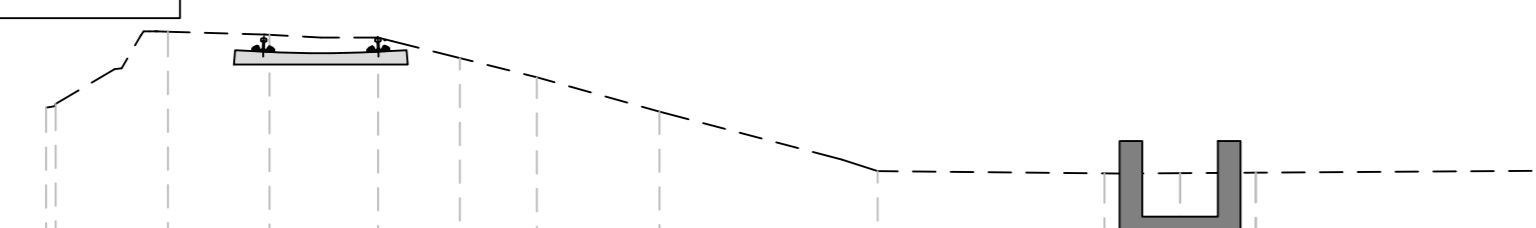

PROGRESSIVE TERRENO	-5.00	-4.67	-3.50	0.00	1.35	5.00
QUOTE TERRENO	286.49	286.78	286.92	286.49	286.45	286.41
DISTANZE PARZIALI TERRENO	1.51	0.97	1.46	1.87	1.15	1.40
PROGRESSIVE PROGETTO	-1.00	-0.80	-0.60	0.00	1.00	1.71
QUOTE PROGETTO	286.48	286.54	286.54	286.54	286.54	286.57
DISTANZE PARZIALI PROGETTO	0.48	0.30	0.30	1.00	0.71	0.00

PK_39+281 - Sez. 10 - Progr. 04045.72
Scala 1:100
Q.RIF. 262.00m

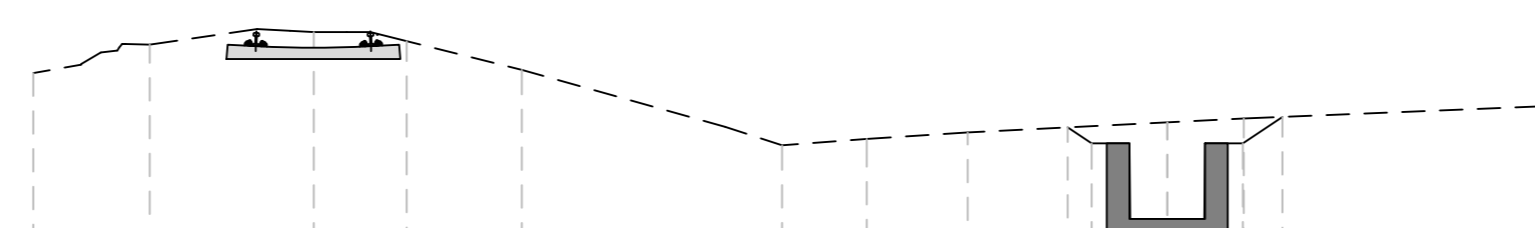

PROGRESSIVE TERRENO	-5.00	-4.61	-3.49	0.00	1.37	5.00
QUOTE TERRENO	286.49	286.78	286.92	286.49	286.45	286.41
DISTANZE PARZIALI TERRENO	1.51	0.97	1.46	1.87	1.16	1.40
PROGRESSIVE PROGETTO	-1.00	-0.80	-0.60	0.00	1.00	1.71
QUOTE PROGETTO	286.49	286.54	286.54	286.54	286.54	286.57
DISTANZE PARZIALI PROGETTO	0.49	0.30	0.30	1.00	0.71	0.00

PK_39+281 - Sez. 12 - Progr. 04051.72
Scala 1:100
Q.RIF. 261.00m



PROGRESSIVE TERRENO	-5.00	-4.59	-3.42	0.00	1.39	5.00
QUOTE TERRENO	286.48	286.67	286.85	286.48	286.45	286.41
DISTANZE PARZIALI TERRENO	1.51	0.96	1.46	1.87	1.15	1.40
PROGRESSIVE PROGETTO	-1.00	-0.80	-0.60	0.00	1.00	1.71
QUOTE PROGETTO	286.57	286.67	286.67	286.67	286.67	286.70
DISTANZE PARZIALI PROGETTO	0.57	0.30	0.30	1.00	0.71	0.00

KEY PLAN - Scala 1:5.000

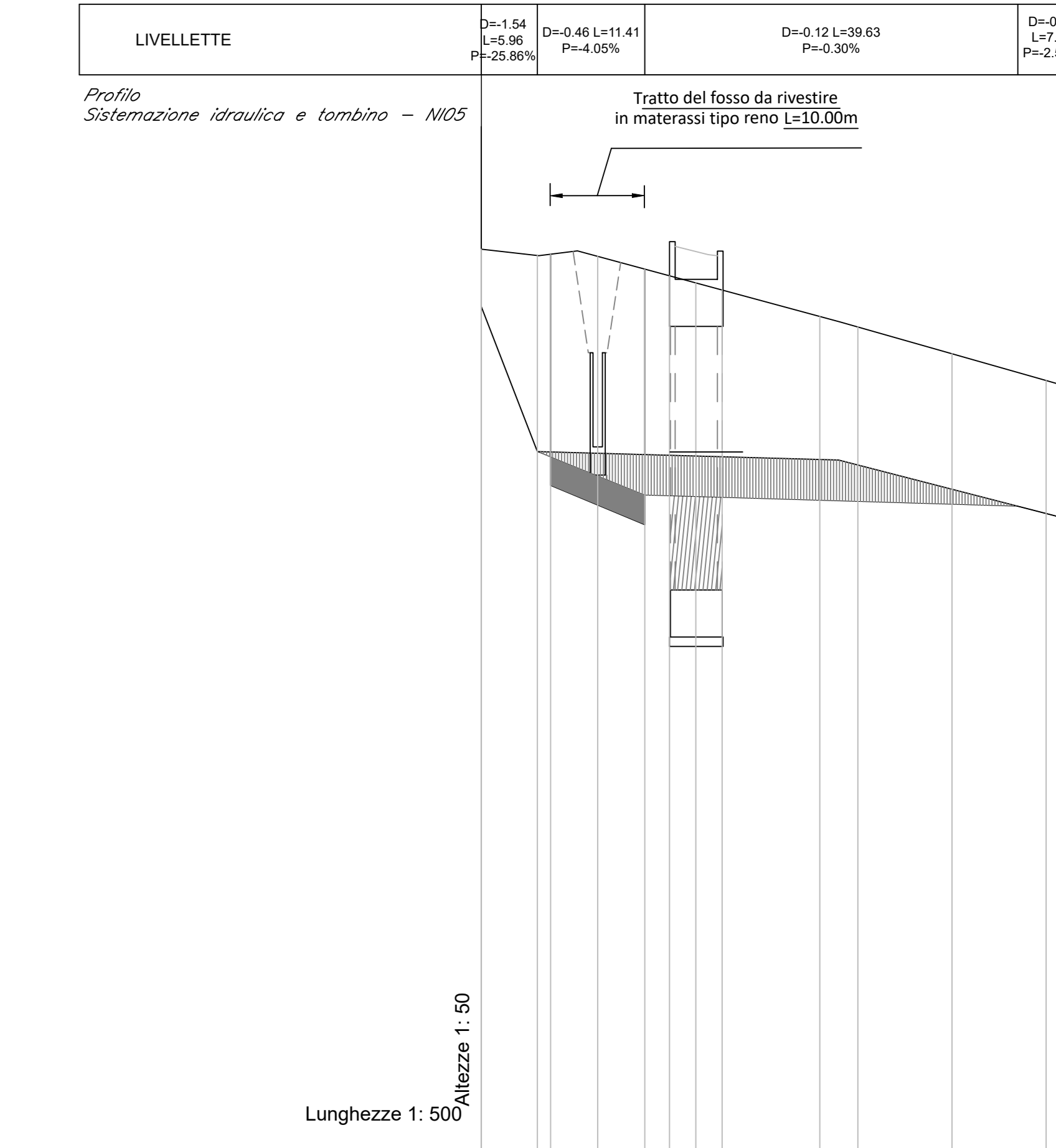
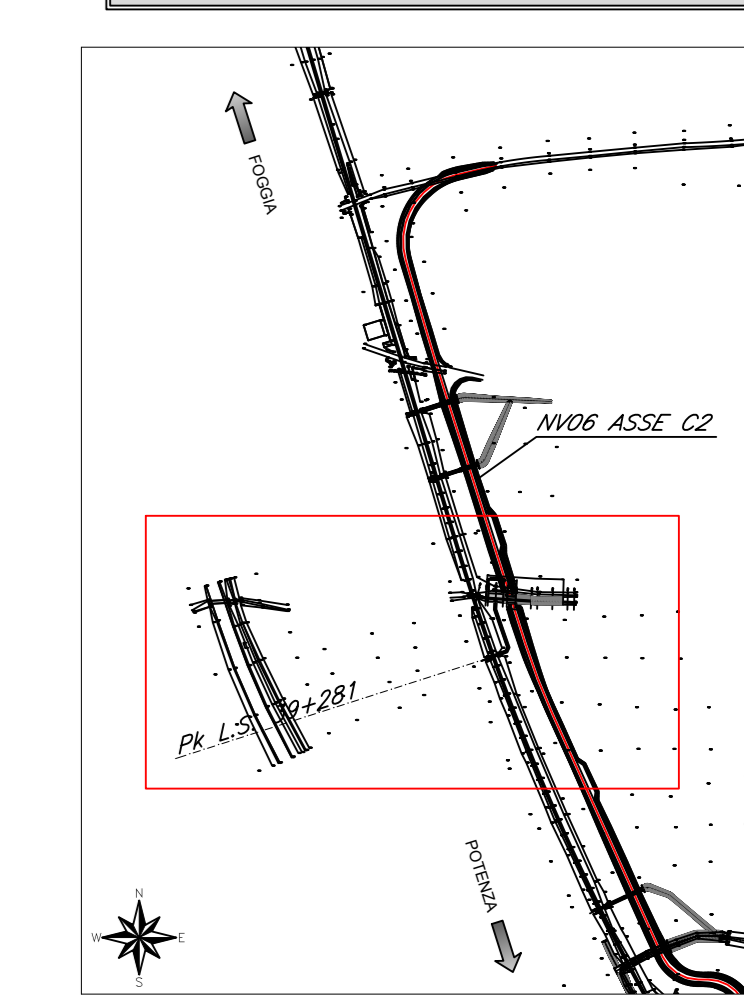

N. SEZIONI	1	2	3	4	5	6	7	8	9	10	11	12	13
DISTANZE PROGRESSIVE	0.00	5.96	12.27	17.25	22.23	27.21	32.19	37.17	42.15	47.13	52.11	57.09	62.07
DISTANZE PARZIALI	5.96	6.31	6.66	7.01	7.36	7.71	8.06	8.41	8.76	9.11	9.46	9.81	10.16
QUOTE TERRENO	286.50	286.57	286.69	286.57	286.51	286.51	286.51	286.51	286.51	286.51	286.51	286.51	286.51
QUOTE PROGETTO FONDO FOSSO	286.50	286.51	286.51	286.51	286.51	286.51	286.51	286.51	286.51	286.51	286.51	286.51	286.51
QUOTE SPORA TERRENO	286.50	286.50	286.50	286.50	286.50	286.50	286.50	286.50	286.50	286.50	286.50	286.50	286.50

COMMITTENTE: **RFI**
R.F. FERROVIARIA ITALIANA
GRUPPO FERROVIARIO DELLA STATO ITALIANO
DIREZIONE REGIONALE INVESTIMENTI FERROVIARIE SUD

PROGETTAZIONE: **ITALFERR**

CONTRATTO ISTITUZIONALE DI SVILUPPO PER LA REALIZZAZIONE DELLA DIRETTRICE FERROVIARIA NAPOLI-BARI-LECCE-TARANTO

S.O. PROGETTAZIONE INTEGRATA SUD

PROGETTO ESECUTIVO

LINEA POTENZA-FOGGIA - AMMODERNAMENTO SOTTOPROGETTO 2 - ELETTRIFICAZIONE, RETTIFICHE DI TRACCIATO, SOPPRESSIONE P.L. E CONSOLIDAMENTO SEDE

LOTTO 2 - RETTIFICHE DI TRACCIATO, SOPPRESSIONE P.L. E CONSOLIDAMENTO SEDE

TOMBINI FERROVIARI - Sistemazione idraulica pk. 39+281
Planimetria di progetto, Profilo, Sezioni

SCALA: varie

COMMESSA LOTTO FASE ENTE TIPO DOC. OPERA/DISCIPLINA PROG. REV.
IA4M 00 E 78 P2 I 00002 002 A

Rev. Descrizione Ricordo Data Verificato Data Approvato Data Autorizzato Data

1 A Emisione autorizzativa 1 Comune Dicembre 2021 02 Dicembre 2021 02 Dicembre 2021

File: IA4M00E78P2I00002002A.dwg In. Elab: