

DIAFRAMMA DI SPALLA

Scala 1:20

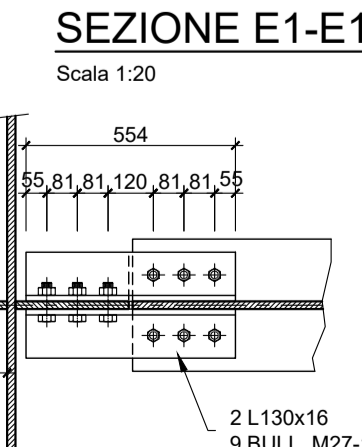

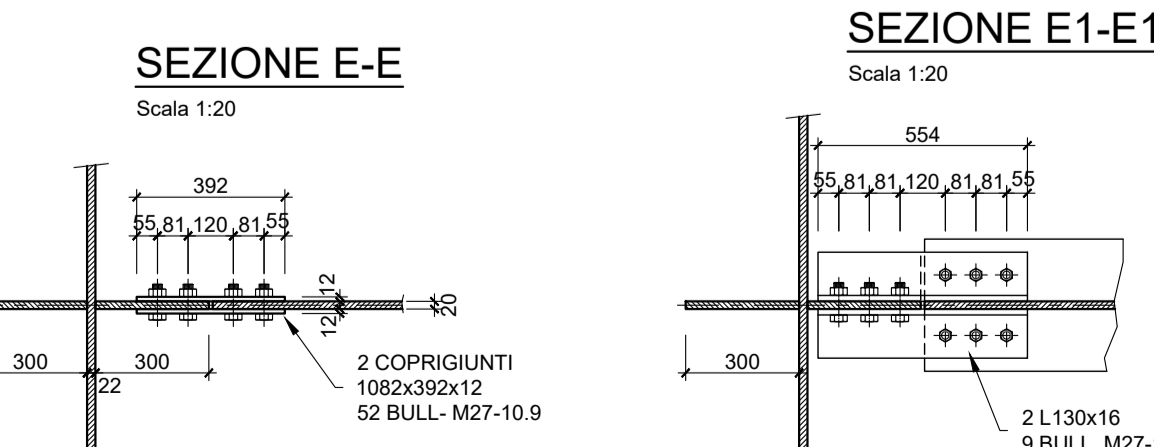
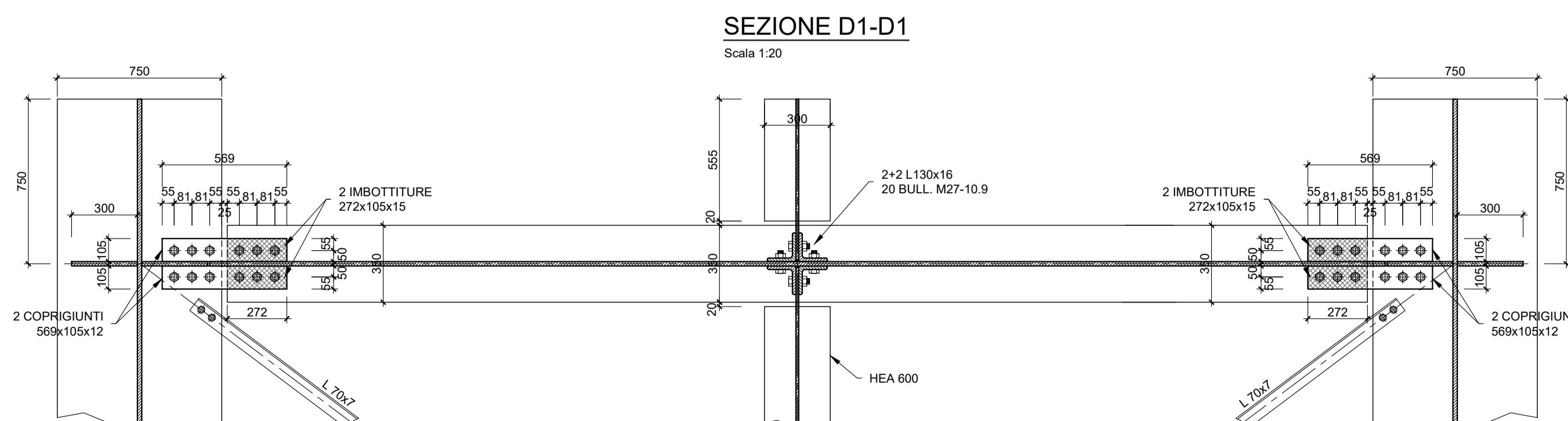
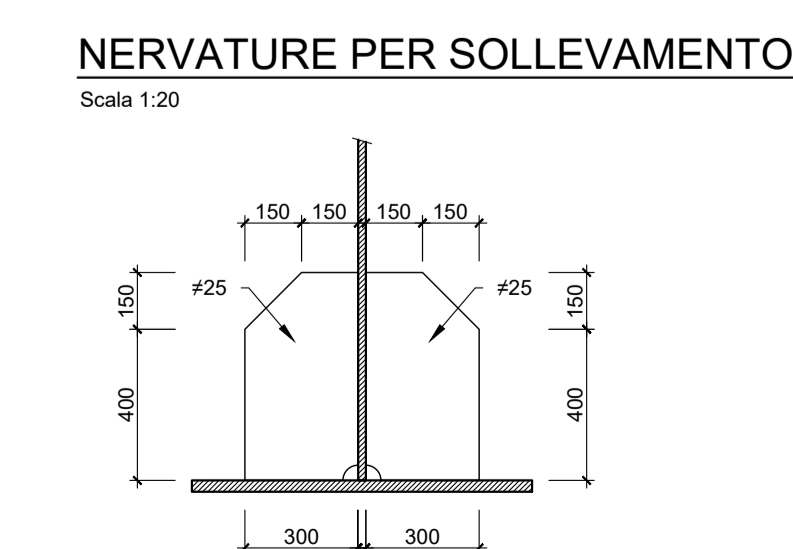
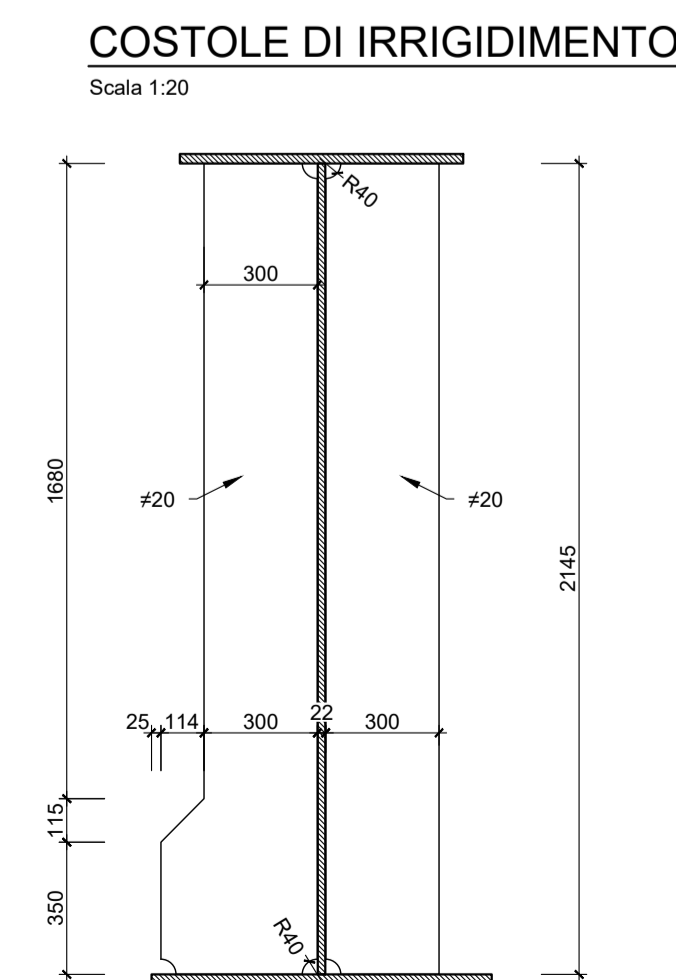
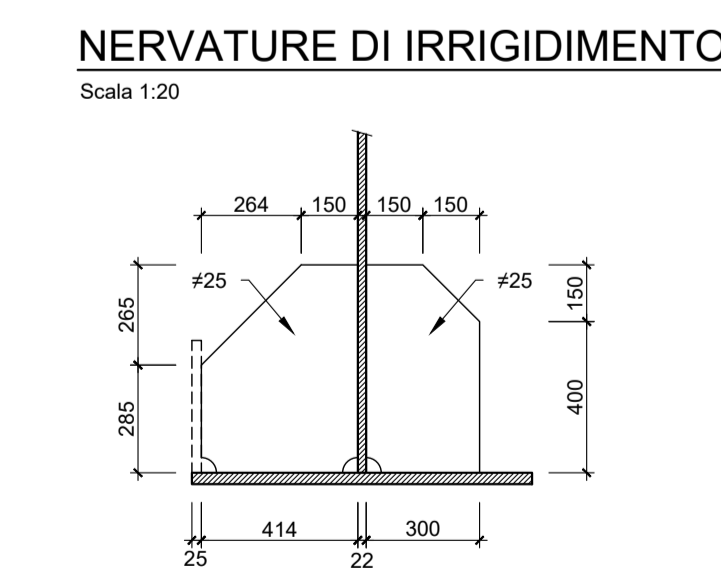
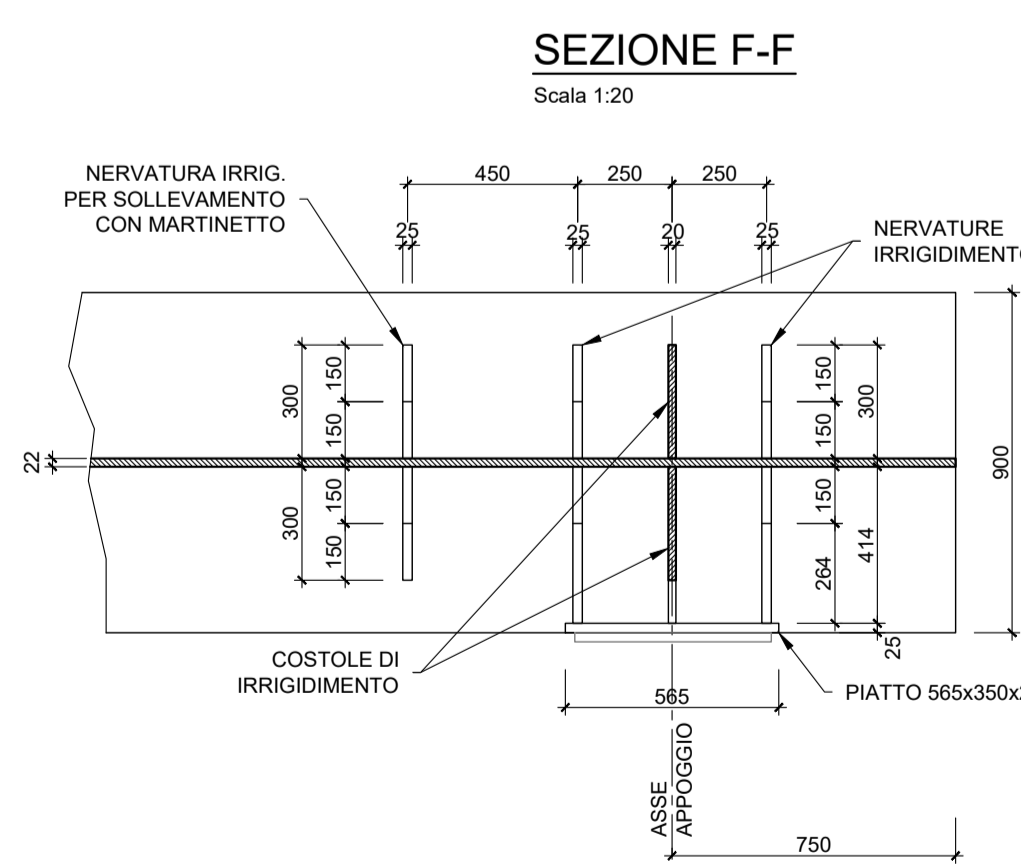
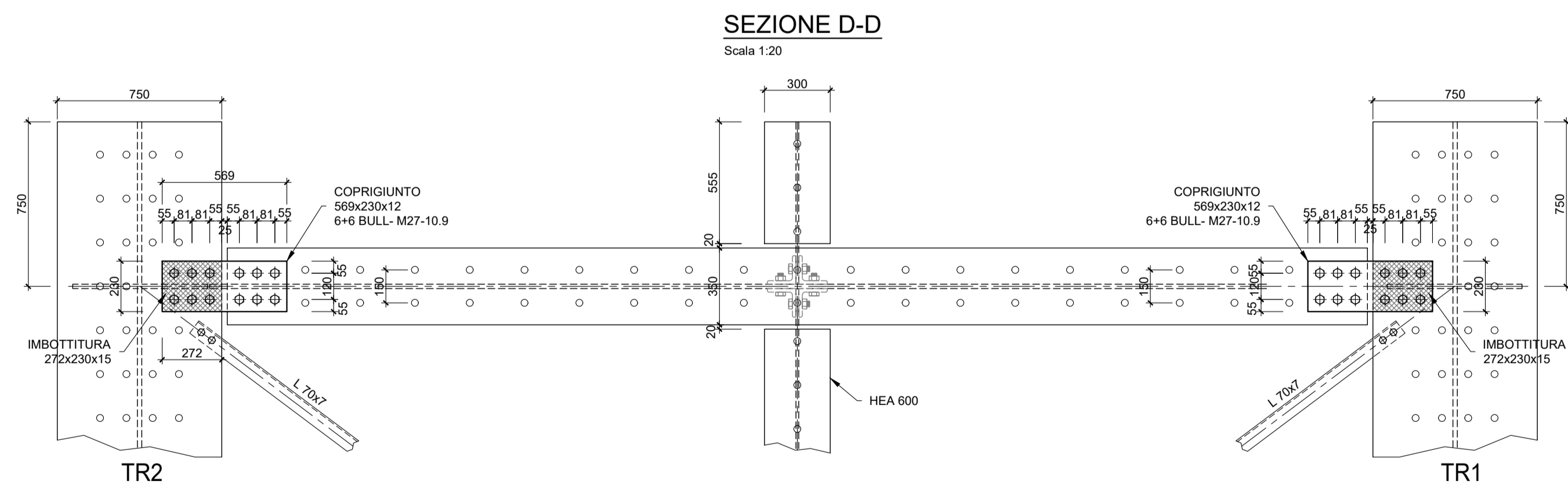
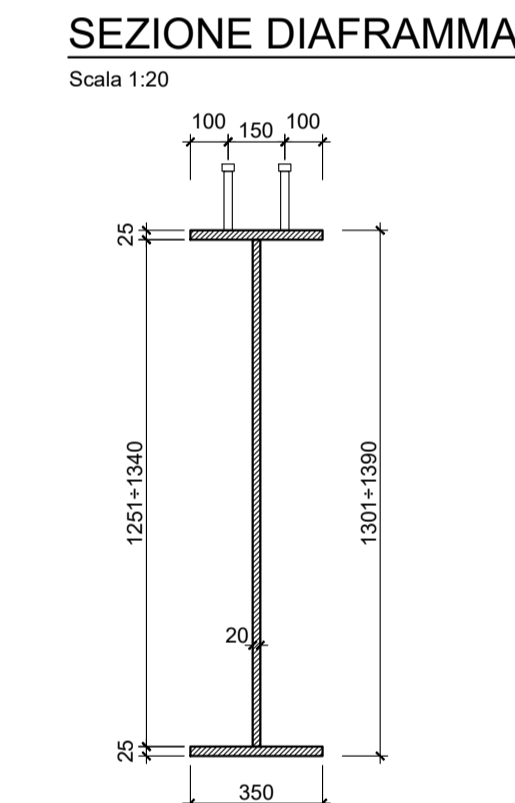
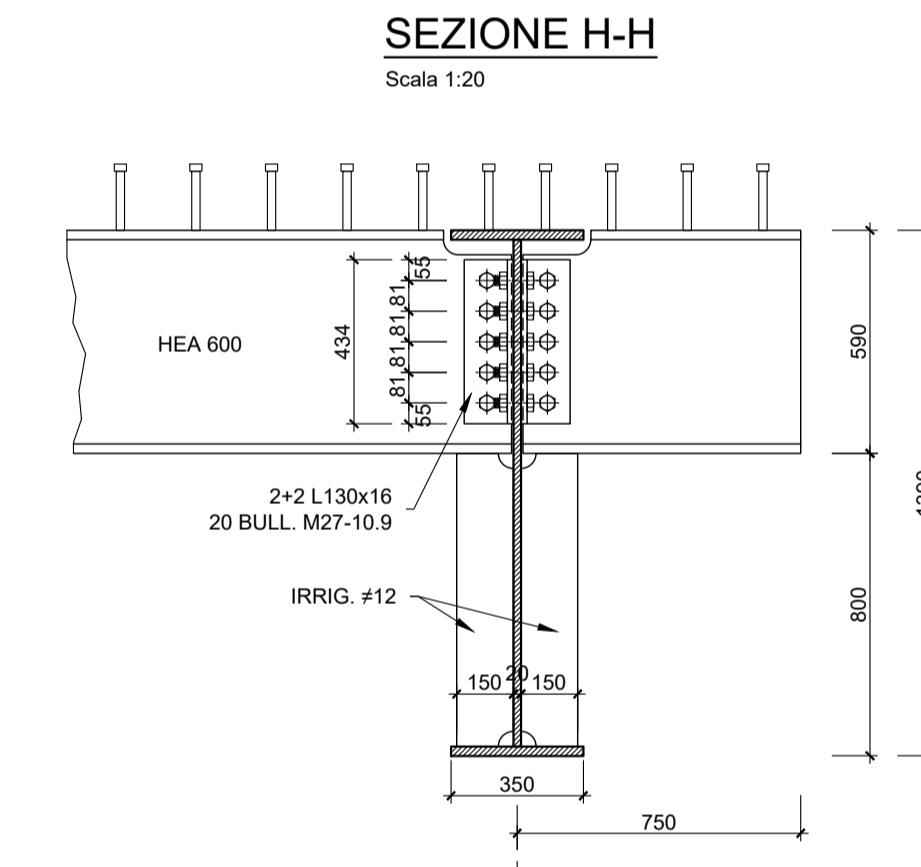
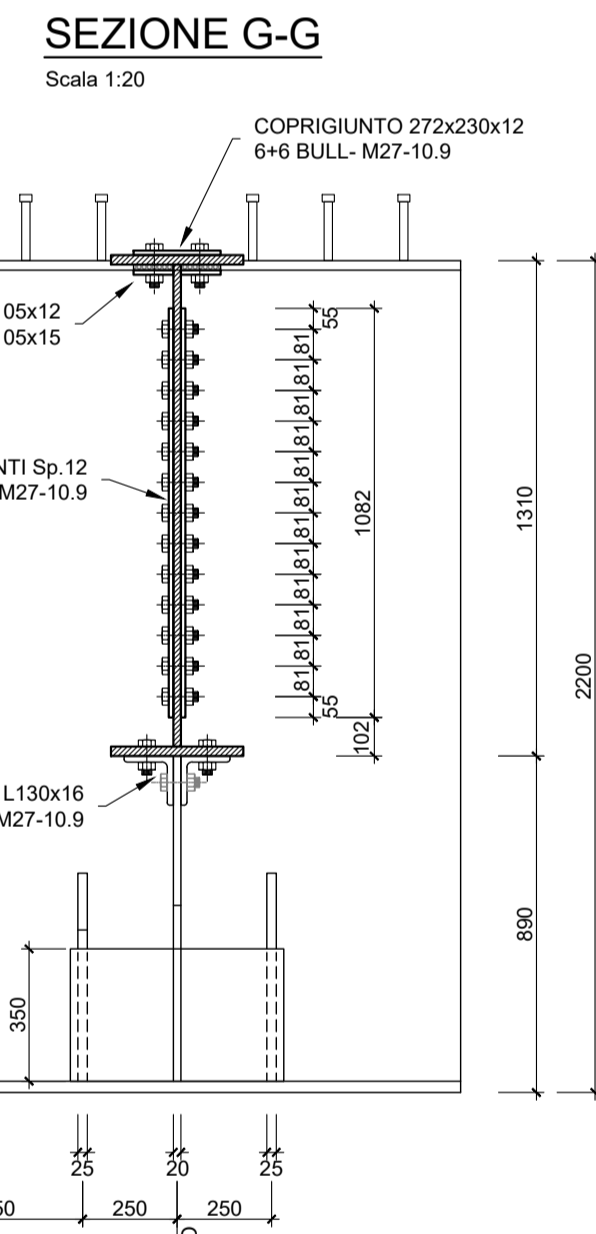
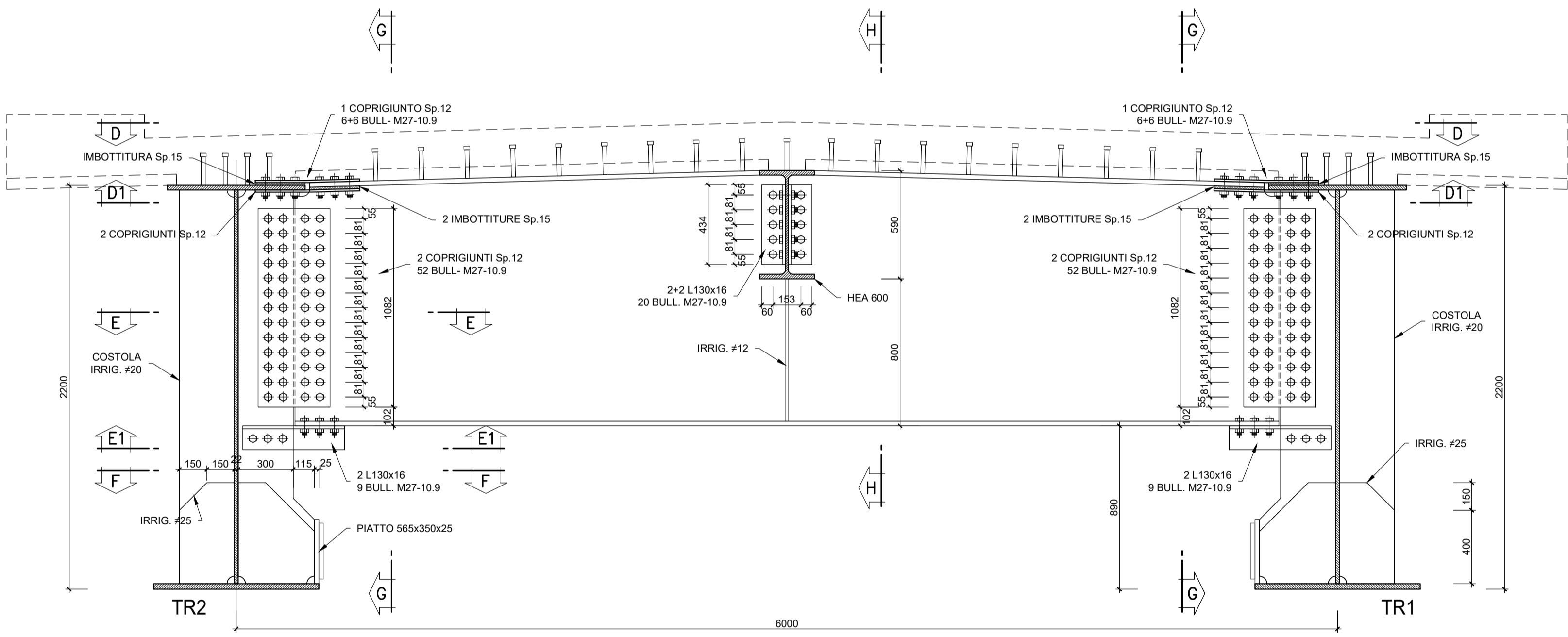

Direzione Progettazione e Realizzazione Lavori

ITINERARIO RAGUSA-CATANIA

Collegamento viario compreso tra lo Svincolo della S.S. 514 "di Chiamarento" con la S.S. 115 e lo Svincolo della S.S. 194 "Ragusana"
LOTTO 1 - Dallo svincolo n. 1 sulla S.S. 115 (compreso) allo svincolo n. 3 sulla S.P. 5 (escluso)

PROGETTO ESECUTIVO

cod. **PA895**

PROGETTAZIONE: ATI SINTAGMA - GP INGEGNERIA - COOPROGETTI - GDG - ICARIA - OMNISERVICE

IL GRUPPO DI PROGETTAZIONE:		IL MANDATARIO:			
PROGETTISTA RESPONSABILE DELL'INTEGRAZIONE DELLE PRESTAZIONI SPECIFICATIVE: Dott. Ing. Nando Graneri Ordine degli Ingegneri della Prov. di Perugia n° 4351	COORDINATORE PER LA SICUREZZA IN FASE DI PROGETTAZIONE: Dott. Ing. Ambrogio Signoroli Ordine degli Ingegneri della Provincia di Roma n° 435111	MANDANTARI: Sintagma CoopProgetti GDG ICARIA Omniservice	Dott. Ing. M. Graneri Dott. Ing. F. Di Stefano Dott. Ing. L. Neri Dott. Ing. G. Quattrucci Dott. Ing. A. Signoroli Dott. Ing. E. Sciorrini Dott. Arch. E. E. Crimi Dott. Arch. P. Di Stefano Dott. Ing. G. Pini	Dott. Ing. M. Adams Dott. Ing. P. Brindani Dott. Ing. L. Caporaso Dott. Ing. G. Longobardi Dott. Ing. L. Pagano Dott. Arch. M. Di Stefano Dott. Arch. M. G. Lianno Dott. Ing. G. Pini Dott. Ing. V. Sciorrini Dott. Ing. C. Sciorrini Dott. Ing. F. Di Stefano Dott. Ing. P. Di Stefano	Dott. Ing. A. Adams Dott. Ing. P. Brindani Dott. Ing. L. Caporaso Dott. Ing. G. Longobardi Dott. Ing. L. Pagano Dott. Arch. M. Di Stefano Dott. Arch. M. G. Lianno Dott. Ing. G. Pini Dott. Ing. V. Sciorrini Dott. Ing. C. Sciorrini Dott. Ing. F. Di Stefano Dott. Ing. P. Di Stefano

IL RESPONSABILE DI PROGETTO:
Dott. Ing. Danilo PELLE
Incarico: Direzione degli Impianti

**CAVALCAVIA
CAVALCAVIA AL KM 3+005
Carpenteria Impalcato: diaframmi**

PROGETTO	UN. PROJ.	N. PROJ.	REVISIONE	SCALA:
L04082	E	2101	A	1:20

NO. FILE	CODICE	REVISIONE	SCALA:
TD1040379C044	T01CV03STRCP04	A	1:20

PROGETTO	UN. PROJ.	N. PROJ.	REVISIONE	SCALA:
L04082	E	2101	A	1:20

REV.	DESCRIZIONE	DATA	REDAITTO	VERIFICATO	APPROVATO
A	EMMISSIONE	GIUGNO 2011	RAMICCI	PELLE	GRANERI