

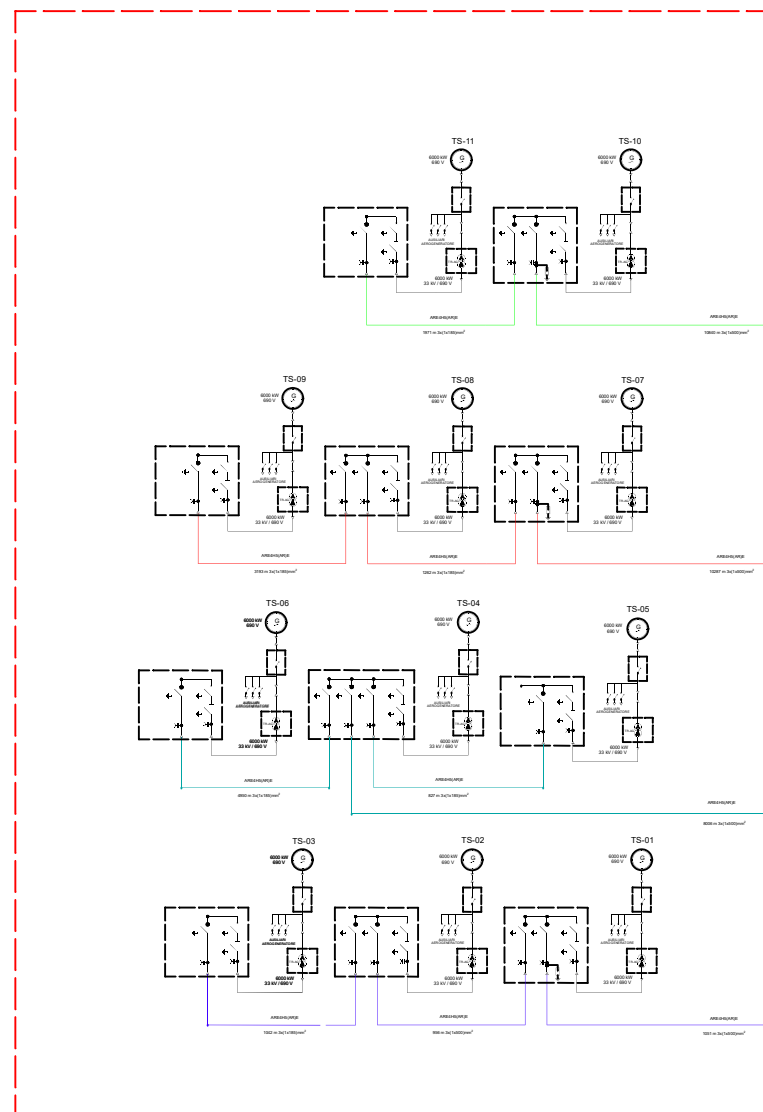

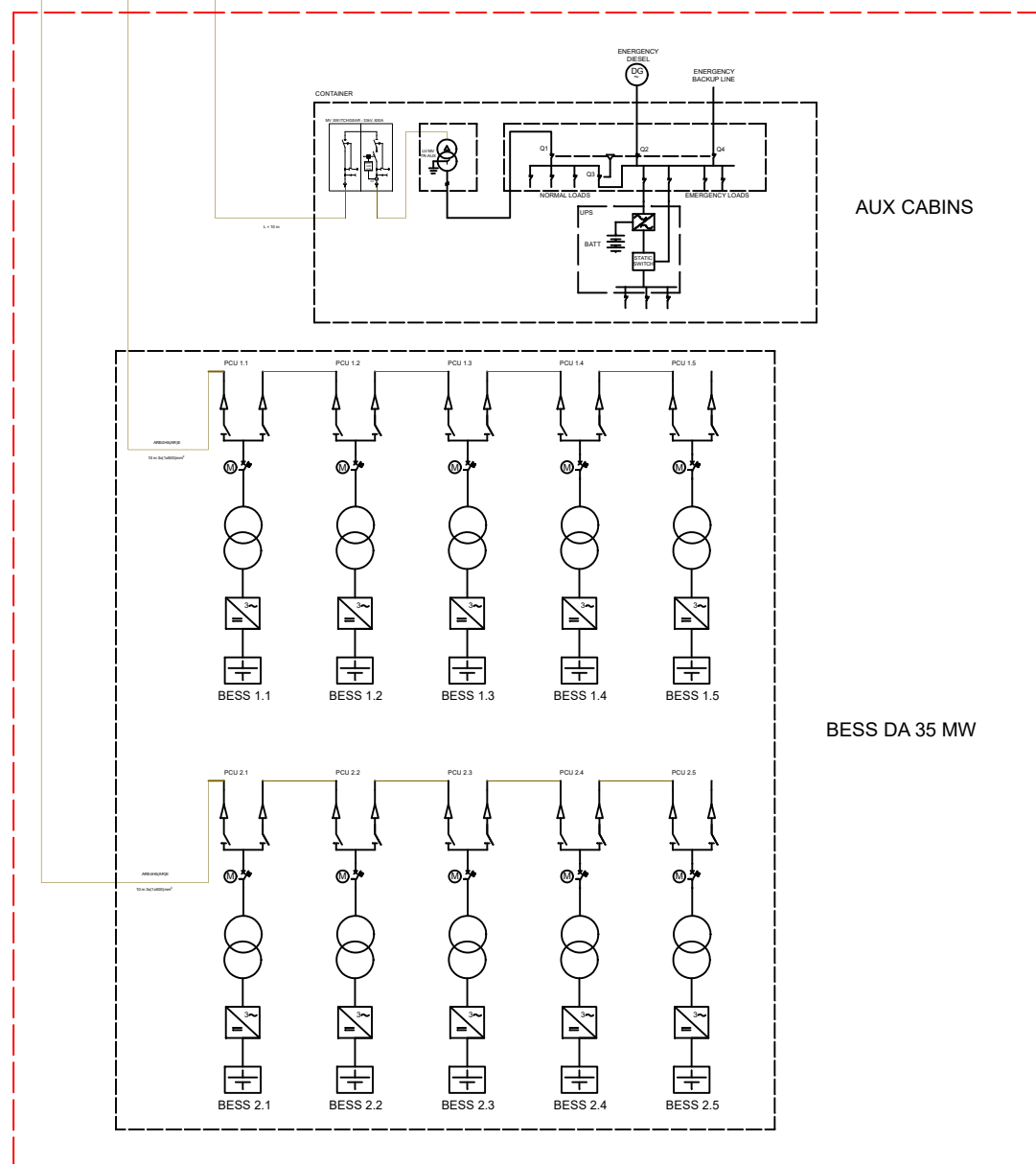



















IMPIANTO EOLICO



IMPIANTO BESS



LEGENDA

-  INTERRUTTORE AT CON COMANDO MOTORIZZATO
-  SEZIONATORE MANUALE AT CON INTERBLOCCO LAME DI TERRA
-  SEZIONATORE MOTORIZZATO ROTATIVO AT CON INTERBLOCCO LAME DI TERRA
-  SCARICATORE
-  TRASFORMATORE DI TENSIONE
-  TRASFORMATORE DI CORRENTE
-  TRASFORMATORE DI POTENZA (COMMUTATORE SOTTO CARICO MOTORIZZATO)
-  TRASFORMATORE SERVIZI AUSILIARI
-  GENERATORE ASINCRONO
-  FUSIBILE
-  INTERRUTTORE MT ASPORTABILE CON COMANDO MOTORIZZATO
-  INDICATORE CAPACITIVO PRESENZA TENSIONE
-  LAME DI MESSA A TERRA
-  INTERRUTTORE AUTOMATICO
-  CONTATTORI DI MANOVRA
-  SEZIONATORE ROTATIVO CON MESSA A TERRA
-  SEZIONATORE ROTATIVO SOTTOCARICO CON MESSA A TERRA
-  LAMPADA DI SEGNALAZIONE
-  BLOCCO A CHIAVE, CHIAVE LIBERA IN APERTO
-  BLOCCO A CHIAVE, CHIAVE LIBERA IN CHIUSO
-  CONTATORE DI ENERGIA ATTIVA/REATTIVA ENTRANTE-USCENTE PER MISURE FISCALI

NOTE

LA SOTTOSTAZIONE AT LATO RTN (TERNI) E' ESISTENTE ED ESCLUSA DALLO SCOPO DEL PROGETTO
 PER CHIAREZZA DI DOCUMENTO L'INSTALLAZIONE A BORDO DELLA TORRE DI GENERAZIONE E' INDICATA NEL DETTAGLIO 1

AUTORIZZAZIONE UNICA EX D. LGS. N. 387/2003



PROGETTO DEFINITIVO
 PARCO EOLICO TURSI SANT'ARCANGELO

Titolo elaborato:
 SOTTOSTAZIONE ELETTRICA UTENTE
 - SCHEMA UNIFILARE

CG	LT	GD	Prima Emissione	11/04/2022	00
REDA	CONTR.	APPROV.	DESCRIZIONE REVISIONE DOCUMENTO	DATA	REV

PROPONENTE



ENERGY PRIME S.R.L.
 Via G. Garibaldi N.15
 74023 Grottaglie (TA)

CONSULENZA



GE.CO.D'OR. S.R.L.
 Via G. Garibaldi n.15
 74023 Grottaglie (TA)

PROGETTISTA
 Ing. Gaetano D'Oronzio
 Via Goito 14 - Colobraro (MT)