



"CARAMMELLE"

1	PROGETTO REV 00	MR	11/21	
REV.	DESCRIZIONE E REVISIONE	Sigla	Data	Firma
EMESSO				

<p><b>GVC</b> SERVIZI DI INGEGNERIA</p> <p>Via della Pineta 1 - 85100 - Potenza email: info@gvcingegneria.it - website: www.gvcingegneria.it C.F. e P.IVA 01737760767 P.E.C.: gvc srl@gigapec.it</p> <p>Direttore Tecnico: dott. ing. MICHELE RESTAINO</p> <p>Collaboratori GVC s.r.l. per il progetto: dott. ing. GIORGIO MARIA RESTAINO dott. ing. CARLO RESTAINO dott. ing. ATTILIO ZOLFANELLI</p> <p><b>GVC s.r.l.</b> Direttore Tecnico Ing. Michele Restaino</p>	<p><b>Nuova Atlantide soc. coop. a r.l.</b></p> <p>Località Palazzo snc - 75011 Accettura - Matera email: progettazione@nuovaatlantide.com</p> <p>Direttore Tecnico: geol. ANTONIO DI BIASE</p> <p>Collaboratore per il progetto: geol. TOMMASO SANTOCHIRICO</p> <p>"Nuova Atlantide" Società Cooperativa Località Palazzo, s.n.c. - 75011 Accettura (MT)</p> <p><i>Antonio Di Biase</i></p> <p><b>ORDINE DEI GEOLOGI DI BASILICATA</b> N. Iscritt. 257</p>	<p><b>Dott. Antonio Bruscella</b></p> <p>Piazza Alcide De Gasperi 27 - 85100 - Potenza email: antonio Bruscella@hotmail.it</p> <p><i>Antonio Bruscella</i></p> <p><b>ANTONIO BRUSCELLA</b> Architetto Piazza Tevere De Ascoli, 27 - 00198 Roma Tel. 06 59882888 www.antonio Bruscella.it P.IVA 01578781007</p>	<p><b>Dott. agr. Paolo Castelli</b></p> <p>Viale Croce Rossa 25 - 90144 - Palermo email: paolo.castelli@hotmail.it P.IVA 0546509826</p> <p><i>Paolo Castelli</i></p> <p><b>ORDINE DEI GEOMETRI E DOTTORE FORESTALI DI BASILICATA</b> Dott. Paolo Castelli N. 1988 ALBO SEZ. A PALERMO</p>
--	---	--	---

<p><b>AMBRA SOLARE 14 s.r.l.</b></p> <p>Via Venti Settembre n.1 - 00187 ROMA, Italia ambrosolare14srl@legalmail.it C.F. e P.IVA 15946241005 SOCIETA' DEL GRUPPO POWERDIS s.r.l.</p>	<p><b>Powerdis</b></p> <p>Via Tevere, 41 - 00198 ROMA, Italia www.powerdis.com</p>	<p><b>Soltec</b></p> <p>Via Tevere, 41 - 00198 ROMA, Italia www.soltech.com</p>
---	--	---

Comune	<b>COMUNE DI FERRANDINA (MT)</b>	COD. RIF	G/139/05/A/01/PD		
		ELABORATO		FILE	
Opera	PROGETTO PER LA REALIZZAZIONE DI UN IMPIANTO AGRIVOLTAICO DI POTENZA NOMINALE PARI A 19.994,88 kWp DENOMINATO "CARAMMELLE" - UBICATO NEL COMUNE DI FERRANDINA (MT) - REGIONE BASILICATA	Categoria	N.°		
		PD		Scala	-----
Oggetto	PROGETTO DEFINITIVO		<b>A.12.b.3</b>		
<b>SCHEMI FUNZIONALI DEI SINGOLI PANNELLI</b>					
Questo disegno è di nostra proprietà riservata a termine di legge e ne è vietata la riproduzione anche parziale senza nostra autorizzazione scritta					



Preliminary Technical Information Sheet



# BiHiKu7

BIFACIAL MONO PERC

635 W ~ 655 W

CS7N-635 | 640 | 645 | 650 | 655MB-AG

### MORE POWER

- 655 W Module power up to 655 W  
Module efficiency up to 21.1 %
- Up to 8.9 % lower LCOE  
Up to 4.6 % lower system cost
- Comprehensive LID / LeTID mitigation technology, up to 50% lower degradation
- Compatible with mainstream trackers, cost effective product for utility power plant
- Better shading tolerance

### MORE RELIABLE

- 40 °C lower hot spot temperature, greatly reduce module failure rate
- Minimizes micro-crack impacts
- Heavy snow load up to 5400 Pa, wind load up to 2400 Pa\*

**12 Years** Enhanced Product Warranty on Materials and Workmanship\*

**30 Years** Linear Power Performance Warranty\*

1<sup>st</sup> year power degradation no more than 2%  
Subsequent annual power degradation no more than 0.45%

\*According to the applicable Canadian Solar Limited Warranty Statement.

### MANAGEMENT SYSTEM CERTIFICATES\*

ISO 9001:2015 / Quality management system  
ISO 14001:2015 / Standards for environmental management system  
OHSAS 18001:2007 / International standards for occupational health & safety

### PRODUCT CERTIFICATES\*

\* As there are different certification requirements in different markets, please contact your local Canadian Solar sales representative for the specific certificates applicable to the products in the region in which the products are to be used.

**CANADIAN SOLAR INC.** is committed to providing high quality solar products, solar system solutions and services to customers around the world. Canadian Solar was recognized as the No. 1 module supplier for quality and performance/price ratio in the IHS Module Customer Insight Survey, and is a leading PV project developer and manufacturer of solar modules, with over 46 GW deployed around the world since 2001.

\* For detailed information, please refer to the Installation Manual.

**CANADIAN SOLAR INC.**  
545 Speedvale Avenue West, Guelph, Ontario N1K 1E6, Canada, www.csisolar.com, support@csisolar.com

### ENGINEERING DRAWING (mm)

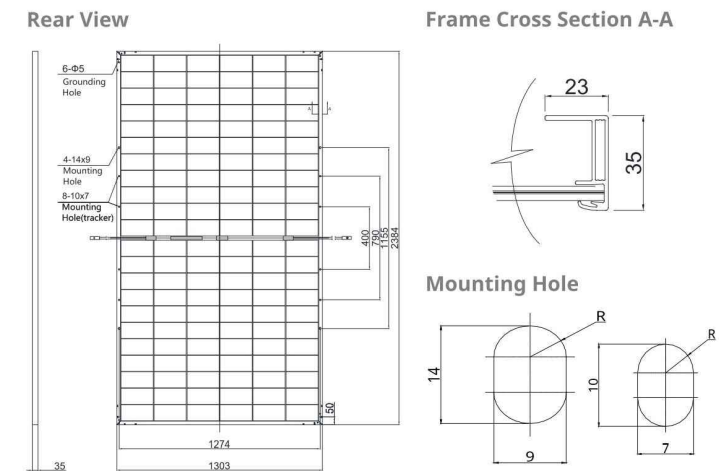

### ELECTRICAL DATA | STC\*

	Nominal Max. Power (Pmax)	Opt. Operating Voltage (Vmp)	Opt. Operating Current (Imp)	Open Circuit Voltage (Voc)	Short Circuit Current (Isc)	Module Efficiency
<b>CS7N-635MB-AG</b>	635 W	36.7 V	17.31 A	44.4 V	18.27 A	20.4%
<b>Bifacial Gain**</b>	5%	667 W	36.7 V	18.18 A	19.18 A	21.5%
	10%	699 W	36.7 V	19.05 A	20.10 A	22.5%
	20%	762 W	36.7 V	20.77 A	21.92 A	24.5%
<b>CS7N-640MB-AG</b>	640 W	36.9 V	17.35 A	44.6 V	18.31 A	20.6%
<b>Bifacial Gain**</b>	5%	672 W	36.9 V	18.22 A	19.23 A	21.6%
	10%	704 W	36.9 V	19.09 A	20.14 A	22.7%
	20%	768 W	36.9 V	20.82 A	21.97 A	24.7%
<b>CS7N-645MB-AG</b>	645 W	37.1 V	17.39 A	44.8 V	18.35 A	20.8%
<b>Bifacial Gain**</b>	5%	677 W	37.1 V	18.26 A	19.27 A	21.8%
	10%	710 W	37.1 V	19.14 A	20.19 A	22.9%
	20%	774 W	37.1 V	20.87 A	22.02 A	24.9%
<b>CS7N-650MB-AG</b>	650 W	37.3 V	17.43 A	45.0 V	18.39 A	20.9%
<b>Bifacial Gain**</b>	5%	683 W	37.3 V	18.32 A	19.31 A	22.0%
	10%	715 W	37.3 V	19.17 A	20.23 A	23.0%
	20%	780 W	37.3 V	20.92 A	22.07 A	25.1%
<b>CS7N-655MB-AG</b>	655 W	37.5 V	17.47 A	45.2 V	18.43 A	21.1%
<b>Bifacial Gain**</b>	5%	688 W	37.5 V	18.35 A	19.35 A	22.1%
	10%	721 W	37.5 V	19.23 A	20.27 A	23.2%
	20%	786 W	37.5 V	20.96 A	22.12 A	25.3%

\* Under Standard Test Conditions (STC) of irradiance of 1000 W/m<sup>2</sup>, spectrum AM 1.5 and cell temperature of 25°C.  
\*\* Bifacial Gain: The additional gain from the back side compared to the power of the front side at the standard test condition. It depends on mounting (structure, height, tilt angle etc.) and albedo of the ground.

### ELECTRICAL DATA

Operating Temperature	-40°C ~ +85°C
Max. System Voltage	1500 V (IEC) or 1000 V (IEC)
Module Fire Performance	CLASS C (IEC61730)
Max. Series Fuse Rating	35 A
Application Classification	Class A
Power Tolerance	0 ~ + 10 W
Power Bifaciality*	70 %

\* Power Bifaciality = Pmax<sub>rear</sub> / Pmax<sub>front</sub>, both Pmax<sub>rear</sub> and Pmax<sub>front</sub> are tested under STC, Bifaciality Tolerance: ± 5 %

\* The specifications and key features contained in this datasheet may deviate slightly from our actual products due to the on-going innovation and product enhancement. Canadian Solar Inc. reserves the right to make necessary adjustment to the information described herein at any time without further notice.  
Please be kindly advised that PV modules should be handled and installed by qualified people who have professional skills and please carefully read the safety and installation instructions before using our PV modules.

**CANADIAN SOLAR INC.**  
545 Speedvale Avenue West, Guelph, Ontario N1K 1E6, Canada, www.csisolar.com, support@csisolar.com

### CS7N-650MB-AG / I-V CURVES

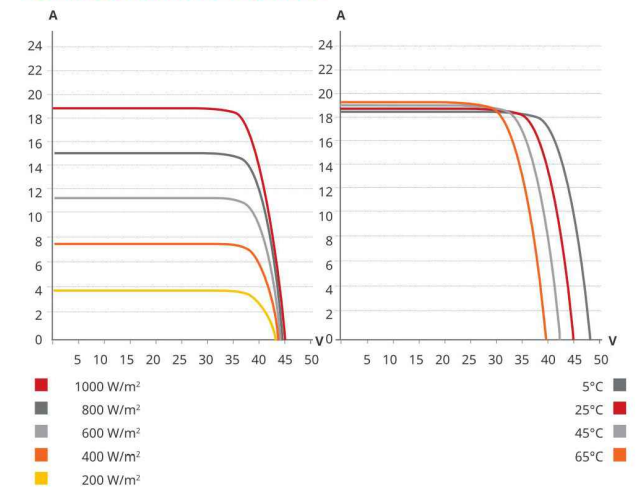

### ELECTRICAL DATA | NMOT\*

	Nominal Max. Power (Pmax)	Opt. Operating Voltage (Vmp)	Opt. Operating Current (Imp)	Open Circuit Voltage (Voc)	Short Circuit Current (Isc)
<b>CS7N-635MB-AG</b>	475 W	34.3 V	13.86 A	41.9 V	14.73 A
<b>CS7N-640MB-AG</b>	479 W	34.5 V	13.89 A	42.1 V	14.77 A
<b>CS7N-645MB-AG</b>	483 W	34.7 V	13.92 A	42.3 V	14.80 A
<b>CS7N-650MB-AG</b>	487 W	34.9 V	13.96 A	42.5 V	14.83 A
<b>CS7N-655MB-AG</b>	490 W	35.1 V	13.98 A	42.7 V	14.86 A

\* Under Nominal Module Operating Temperature (NMOT), irradiance of 800 W/m<sup>2</sup> spectrum AM 1.5, ambient temperature 20°C, wind speed 1 m/s.

### MECHANICAL DATA

Specification	Data
Cell Type	Mono-crystalline
Cell Arrangement	132 [2 x (11 x 6)]
Dimensions	2384 x 1303 x 35 mm (93.9 x 51.3 x 1.38 in)
Weight	39.4 kg (86.9 lbs)
Front / Back Glass	2.0 mm heat strengthened glass
Frame	Anodized aluminium alloy
J-Box	IP68, 3 diodes
Cable	4.0 mm <sup>2</sup> (IEC)
Cable Length (Including Connector)	460 mm (18.1 in) (+) / 340 mm (13.4 in) (-) or customized length*
Connector	T4 series or H4 UTX or MC4-EVO2
Per Pallet	30 pieces
Per Container (40' HQ)	480 pieces

\* For detailed information, please contact your local Canadian Solar sales and technical representatives.

### TEMPERATURE CHARACTERISTICS

Specification	Data
Temperature Coefficient (Pmax)	-0.35 % / °C
Temperature Coefficient (Voc)	-0.27 % / °C
Temperature Coefficient (Isc)	0.05 % / °C
Nominal Module Operating Temperature	41 ± 3°C

### PARTNER SECTION

