

STRUTTURE PER MODULI FTV DEL TIPO AD INSEGUITORE MONOASSIALE - DA 2 STRINGHE DA 32 MODULI

Vista in pianta - Scala 1:100

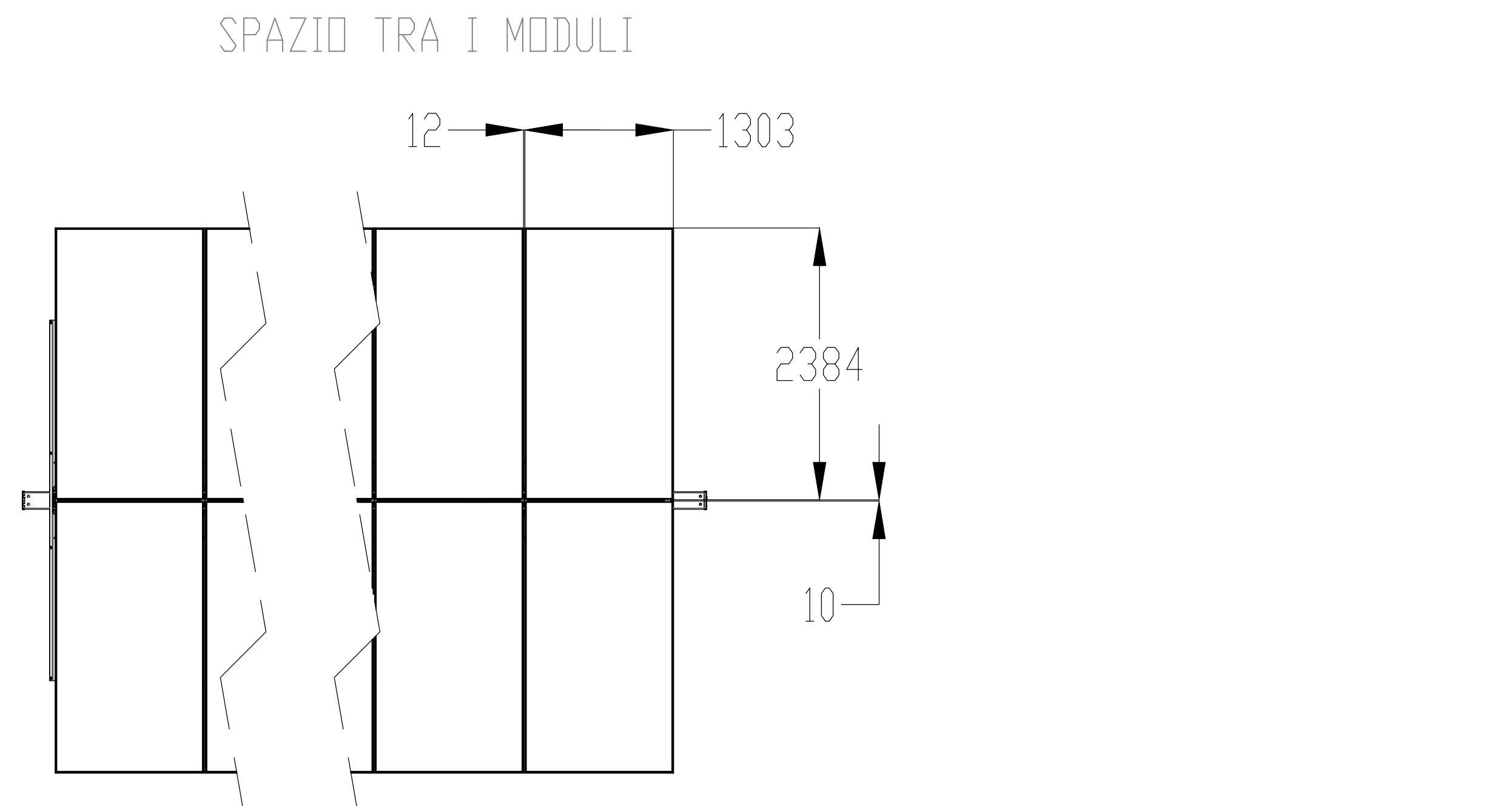

2x30 CONFIGURAZIONE

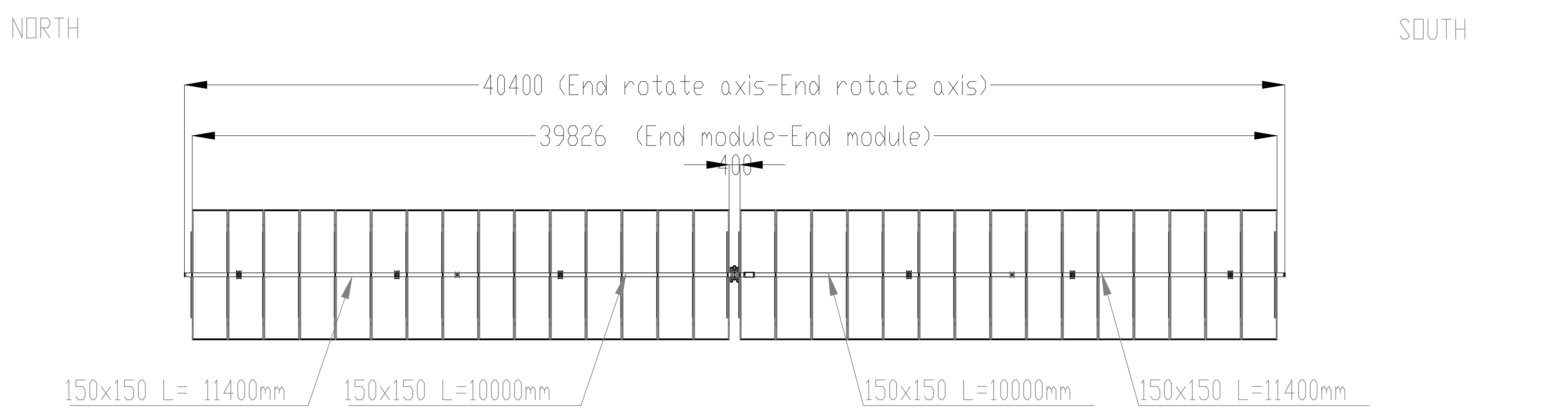
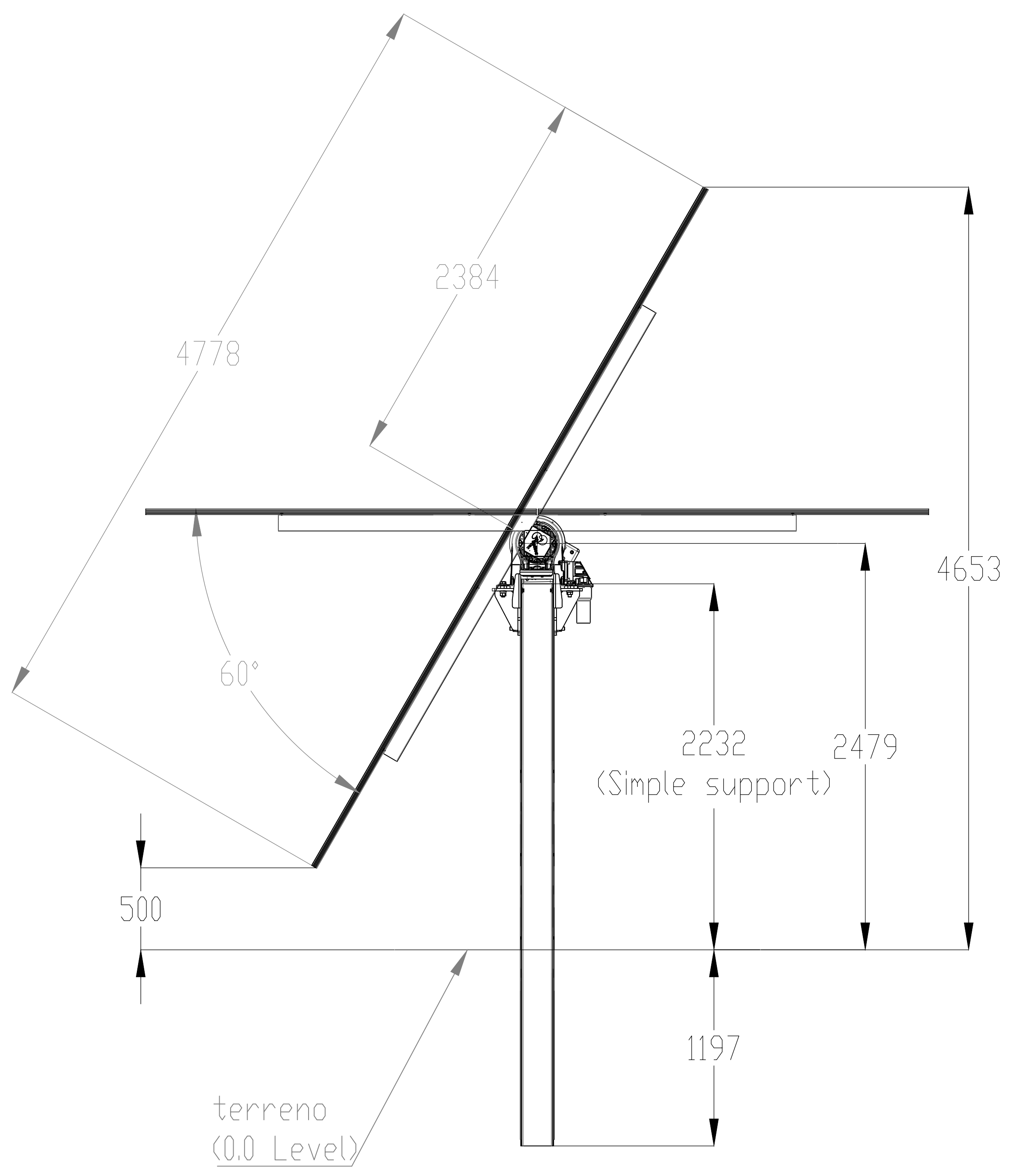
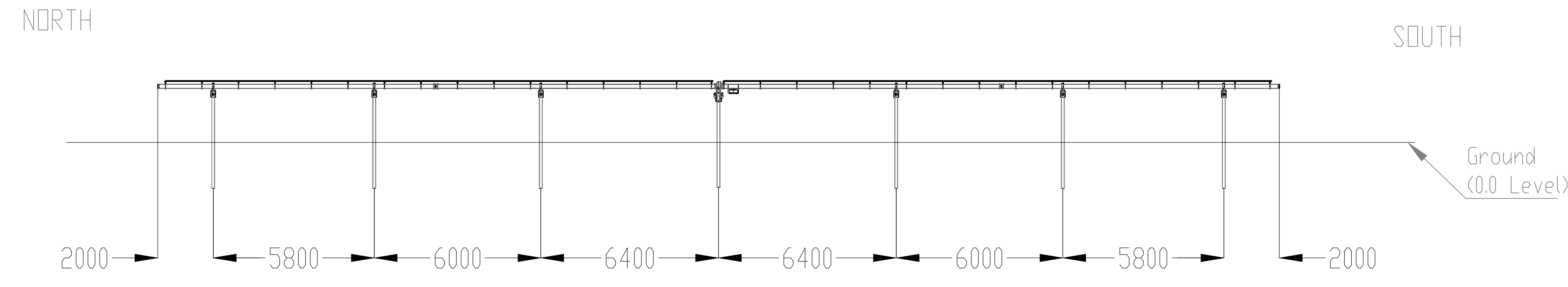

STRUTTURE PER MODULI FTV DEL TIPO AD INSEGUITORE MONOASSIALE

Vista in prospettiva - Scala 1:25

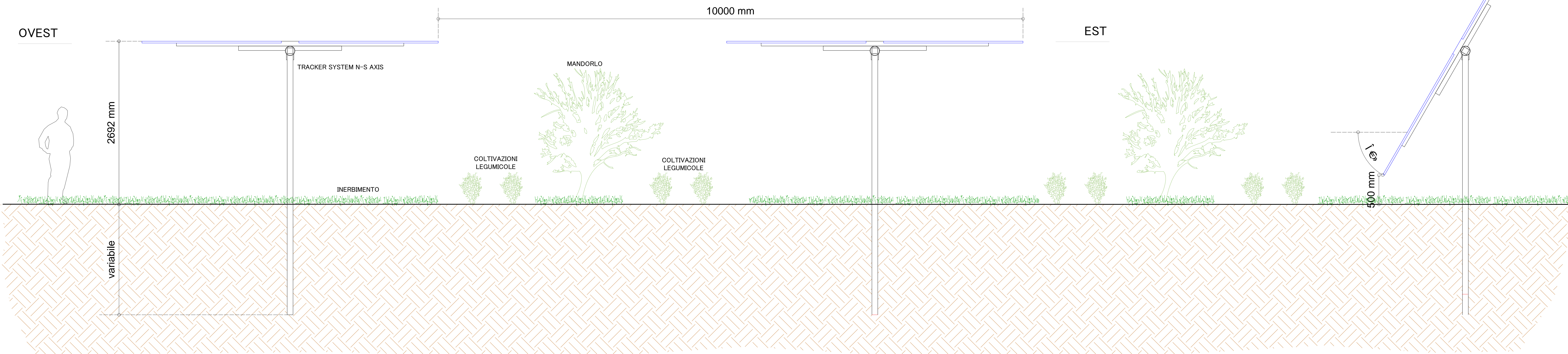

MODULO FOTOVOLTAICO CANADIAN-SOLAR - HiKu7 Mono CS7N-660MS

ENGINEERING DRAWING (mm)

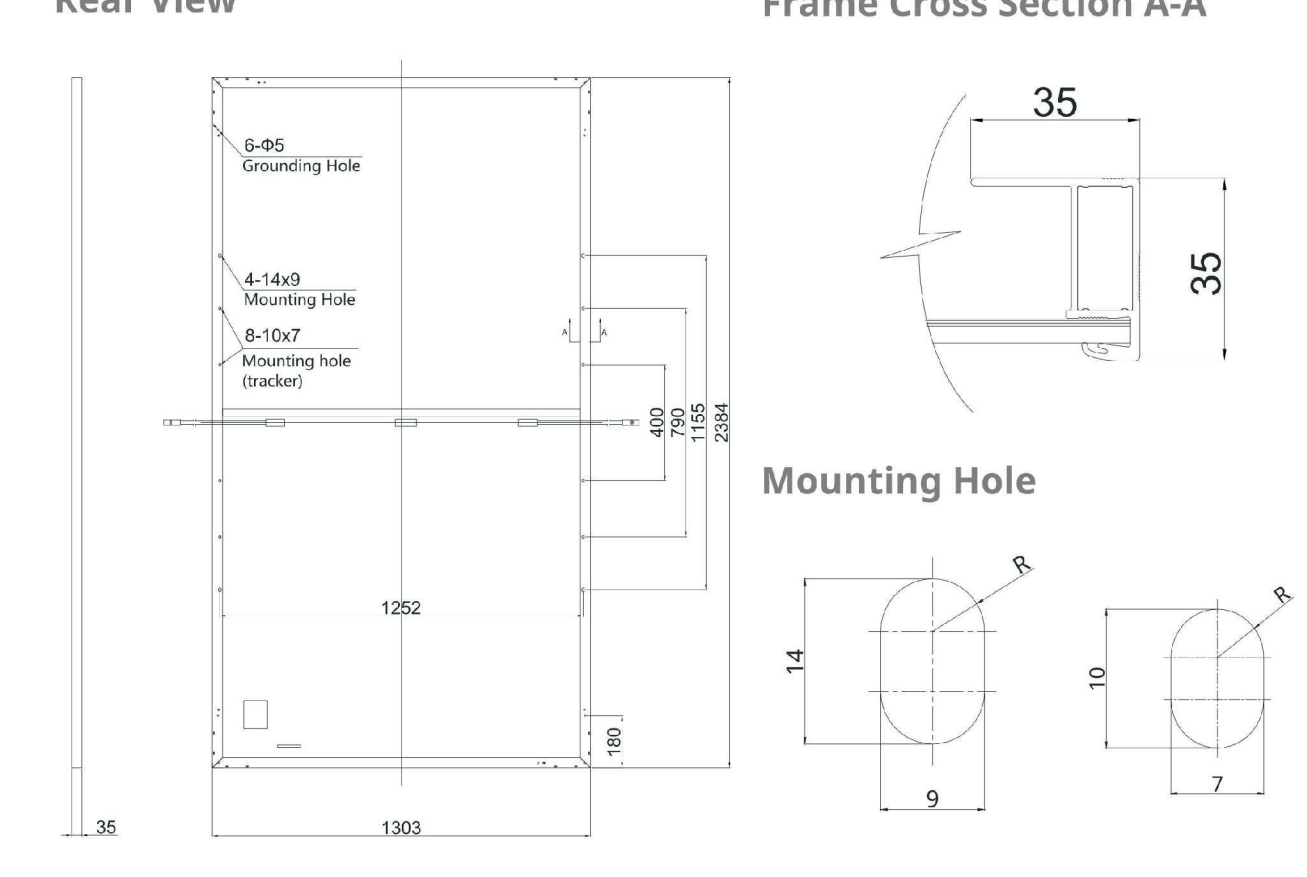

ELECTRICAL DATA | STC*

CS7N	640MS	645MS	650MS	655MS	660MS	665MS
Nominal Max. Power (Pmax)	640 W	645 W	650 W	655 W	660 W	665 W
Opt. Operating Voltage (Vmp)	37.5 V	37.7 V	37.9 V	38.1 V	38.3 V	38.5 V
Opt. Operating Current (Imp)	17.07 A	17.11 A	17.16 A	17.20 A	17.24 A	17.28 A
Open Circuit Voltage (Voc)	44.6 V	44.8 V	45.0 V	45.2 V	45.4 V	45.6 V
Short Circuit Current (Isc)	18.31 A	18.35 A	18.39 A	18.43 A	18.47 A	18.51 A
Module Efficiency	20.6%	20.8%	20.9%	21.1%	21.2%	21.4%
Operating Temperature	-40°C - +85°C					
Max. System Voltage	1500V (IEC) or 1000V (IEC)					
Module Fire Performance	CLASS C (IEC 61730)					
Max. Series Fuse Rating	30 A					
Application Classification	Class A					
Power Tolerance	0 - +10 W					

* Under Standard Test Conditions (STC) of irradiance of 1000 W/m², spectrum AM 1.5 and cell temperature of 25°C.

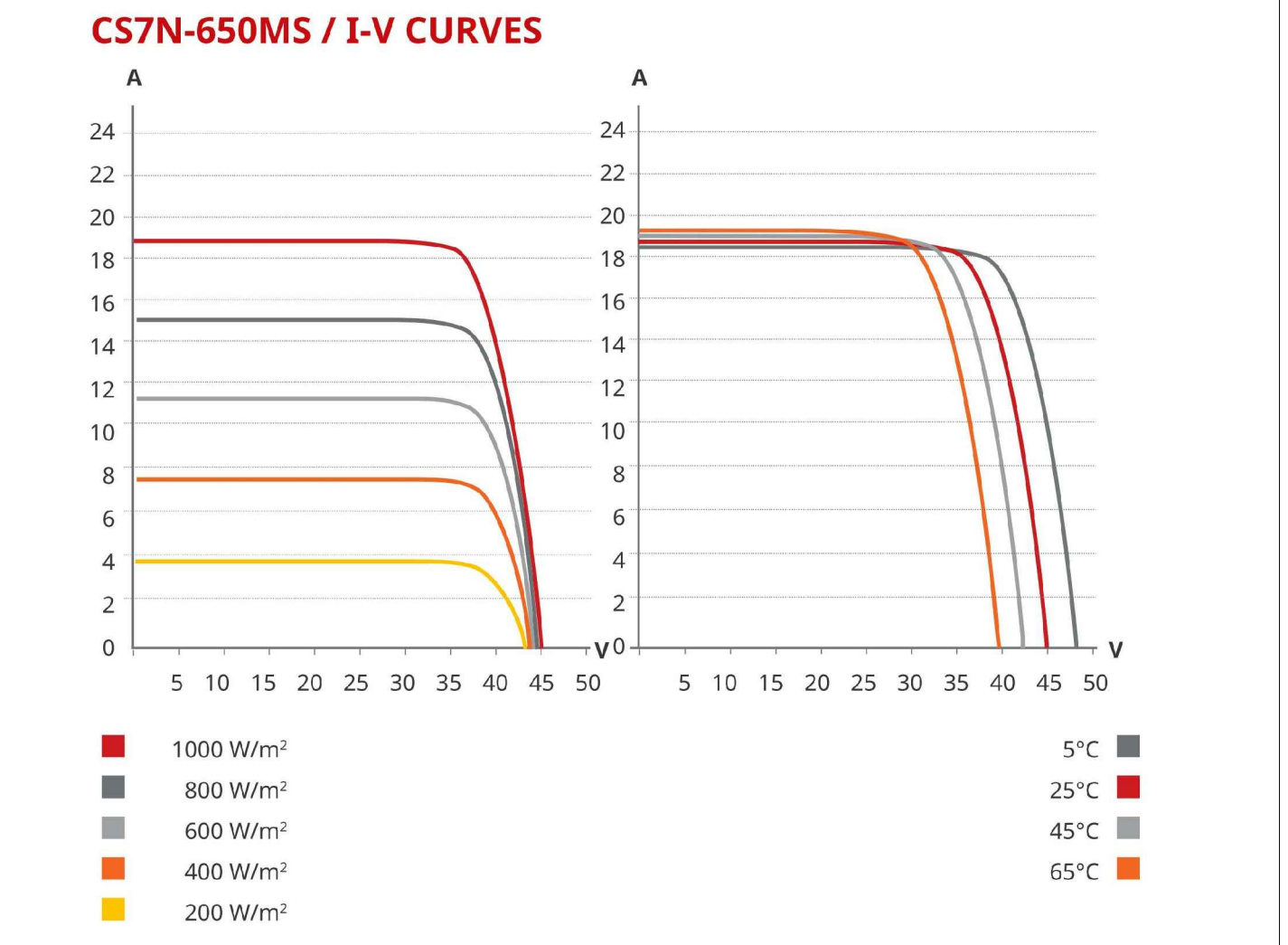

MECHANICAL DATA

Specification	Data
Cell Type	Mono-crystalline
Cell Arrangement	132 [2 x (11 x 6)]
Dimensions	2384 x 1303 x 35 mm (93.9 x 51.3 x 1.38 in)
Weight	35.7 kg (78.7 lbs)
Front Cover	3.2 mm tempered glass
Frame	Anodized aluminium alloy, crossbar enhanced
J-Box	IP68, 3 bypass diodes
Cable	4 mm² (IEC)
Cable Length	460 mm (18.1 in) (+) / 340 mm (13.4 in) (-) or customized length*
Connector	T4 series or H4 UTX or MC4-EVO2

PROGETTO REV.00

DESCRIZIONE E REVISIONI	M/N	11/21	Final
-------------------------	-----	-------	-------

PROGETTAZIONE	Rev. 00	11/21	Final
---------------	---------	-------	-------

PROGETTO	Rev. 00	11/21	Final
----------	---------	-------	-------

AMBRA SOLARE 39 s.r.l. | **PowerTis** | **Soltec**

COMUNE DI CRACO (MT)

PROGETTO PER LA REALIZZAZIONE DI UN IMPIANTO FOTOVOLTAICO A TRACCE MONOASSIALE PER LA POTENZA NOMINALE DI 10 MWp IN UN'AREA SU SUOLA STRUTTURATA CON SUPERFICIE DI 280000 mq. (280000 m²). (CANTIERE N. 10) - LOCALITA' DI CRACO (MT) - PROV. DI MASSA MARITTIMA.

PROGETTO DEFINITIVO

DISEGNI ARCHITETTONICI PANNELLI E PARTICOLARI SISTEMI DI ANCORAGGIO

Scale: A.12.b.9