



AUTOSTRADA REGIONALE CISPADANA DAL CASELLO DI REGGIOLO-ROLO SULLA A22 AL CASELLO DI FERRARA SUD SULLA A13

CODICE C.U.P. E81B0800060009

PROGETTO DEFINITIVO

ASSE AUTOSTRADALE (COMPRESIVO DEGLI INTERVENTI LOCALI DI COLLEGAMENTO VIARIO AL SISTEMA AUTOSTRADALE)

PROGETTAZIONE STRADALE
INTERCONNESSIONI E SVINCOLI
SVINCOLO DI SAN FELICE SUL PANARO - FINALE EMILIA
SEZIONI TRASVERSALI - ALBUM

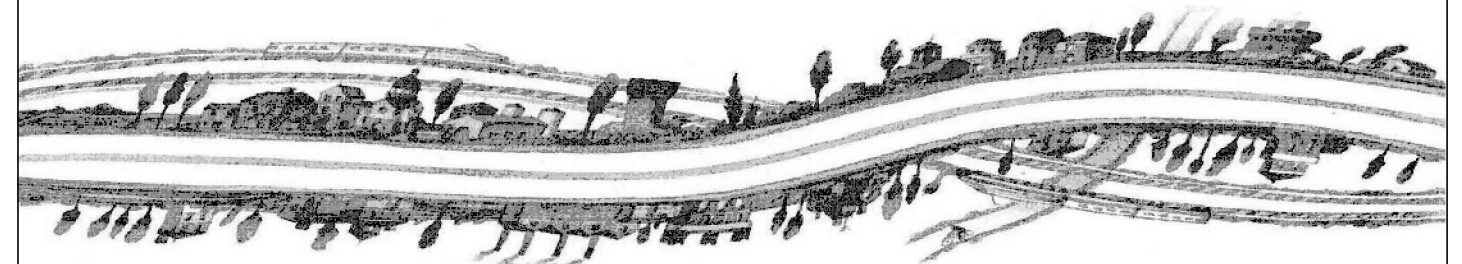

IL PROGETTISTA

PIACENTINI INGEGNERI S.r.l.
Ing. Luca Piacentini
Albo Ing. Bologna n° 4152



RESPONSABILE INTEGRAZIONE
PRESTAZIONI SPECIALISTICHE

Ing. Emilio Salsi
Albo Ing. Reggio Emilia n° 945



IL CONCESSIONARIO

Autostrada Regionale
Cispadana S.p.A.
IL PRESIDENTE
Graziano Pattuzzi

Graziano Pattuzzi

G					
F					
E					
D					
C					
B					
A	17.04.2012	Emissione	Martignani	Piacentini	Salsi
REV.	DATA	DESCRIZIONE	REDAZIONE	CONTROLLO	APPROVAZIONE

IDENTIFICAZIONE ELABORATO

NUM. PROGR.	FASE	LOTTO	GRUPPO	CODICE OPERA WBS	TRATTO OPERA	AMBITO	TIPO ELABORATO	PROGRESSIVO	REV.
1193	PD	0	S03	SRA00	0	SD	SZ	01	A

DATA: MAGGIO 2012

SCALA: 1:200

SVINCOLO DI SAN FELICE SUL PANARO - FINALE EMILIA
RAMO CF
SRA12

PROFILO SV-FINALE-CF
 SEZIONE CF-2
 PROGRESSIVA 25.00

- BASE
- C1 0.63 mq.
- CEMENTATO
- CE1 0.95 mq.
- SOTTOFONDAZIONE STRADALE
- H1 3.79 mq.
- RILEVATO
- RI1 28.39 mq.
- TAPPETO DRENANTE
- a1 6.31 ml.
- BINDER
- b1 6.31 ml.
- BONIFICA
- bo1 6.31 ml.
- SCOTICO
- sc1 6.31 ml.

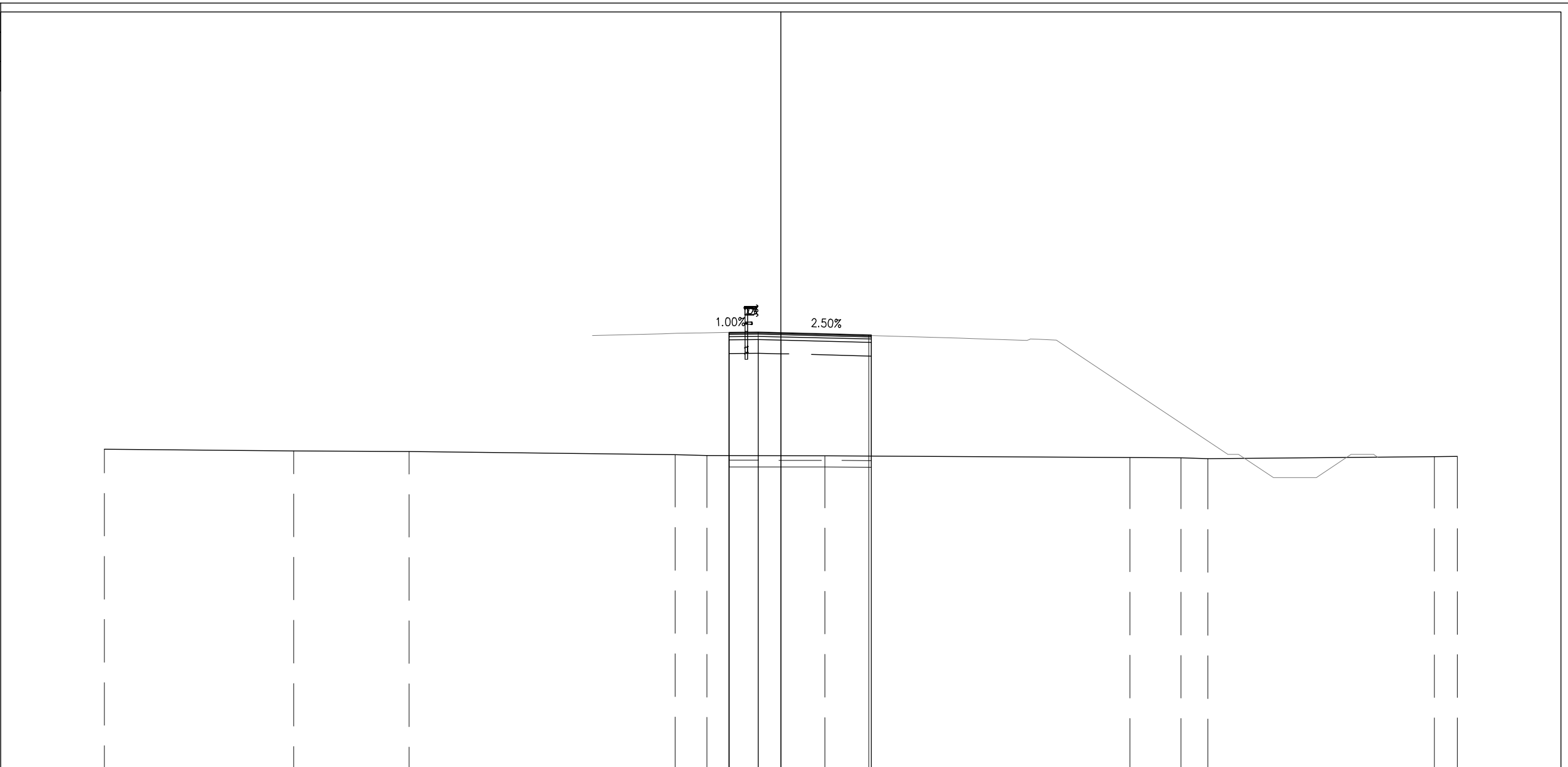

PROGRESSIVE TERRENO	-30.00	-21.61	-16.46	-4.69	-3.28	1.96	15.48	17.75	18.93	28.98	30.00
PARZIALI TERRENO	8.39	5.13	11.79	1.41	5.24	13.52	2.27	1.18	10.05	1.02	
QUOTE TERRENO	13.21	13.13	13.10	12.96	12.92	12.91	12.83	12.82	12.79	12.88	12.88
PROGRESSIVE PROGETTO					-2.30	-1.00	0.00	3.90	4.01		
PARZIALI PROGETTO					1.30	1.00	3.90	0.1			
QUOTE PROGETTO					18.38	18.39	18.37	18.27	18.27		
PROGRESSIVE RILEVATO				-2.30	-2.30	-1.00	0.00	4.01	4.01		
PARZIALI RILEVATO					1.30	1.00	4.01				
QUOTE RILEVATO				18.05	12.92	18.06	18.04	12.90	17.94		

PROFILO SV-FINALE-CF
 SEZIONE CF-3
 PROGRESSIVA 50.00

- BASE 0.82 mq.
- C1 CEMENTATO 1.21 mq.
- CE1 SOTTOFONDAZIONE STRADALE 4.91 mq.
- H1 RILEVATO 36.62 mq.
- RI1 TAPPETO DRENANTE 8.16 ml.
- a1 BINDER 8.16 ml.
- b1 BONIFICA 8.16 ml.
- bo1 SCOTICO 8.16 ml.
- sc1

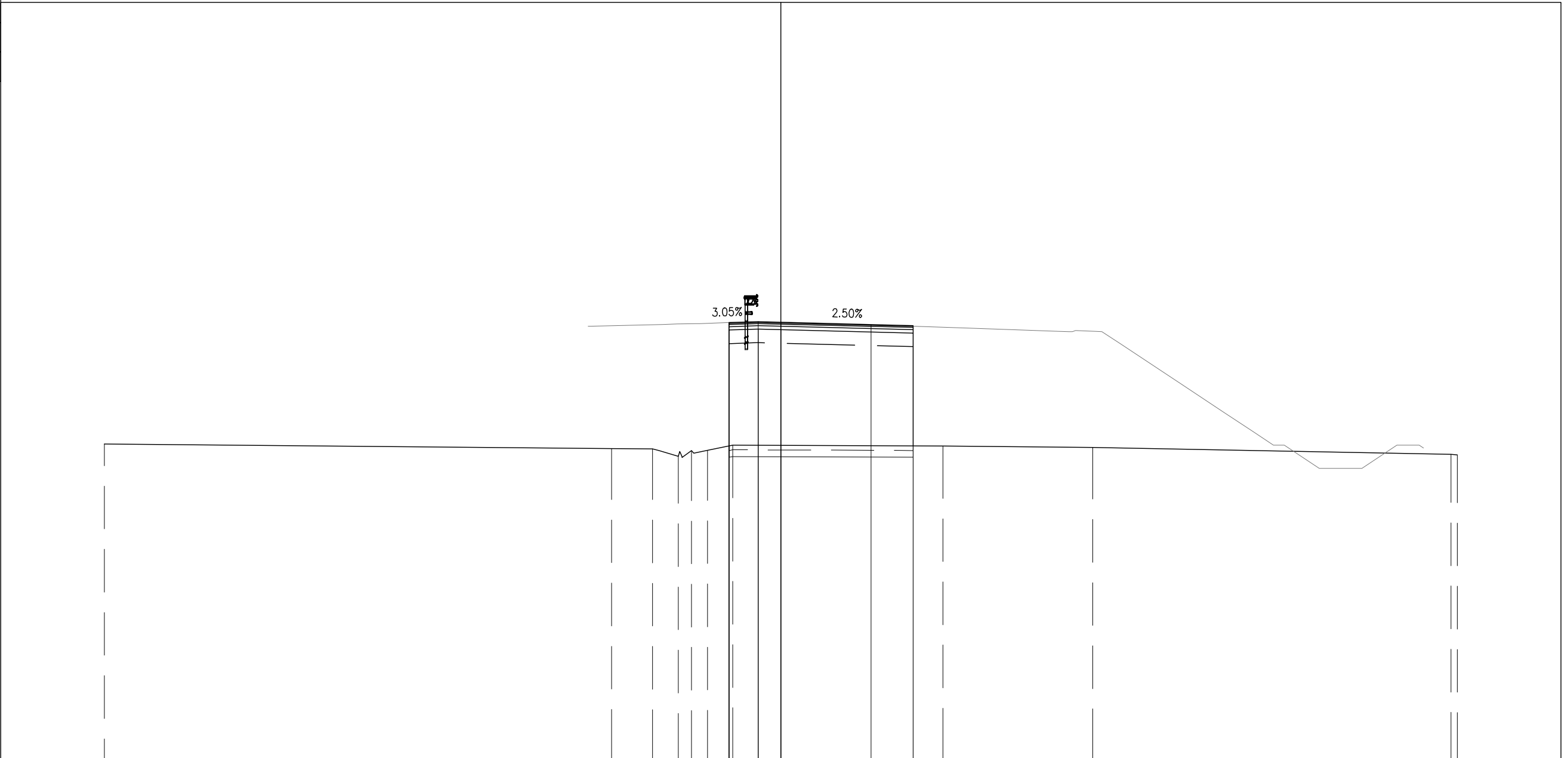

PROGRESSIVE TERRENO	-30.00			-7.50	-5.69	-4.55	-3.96	-3.26	-2.13		7.19	13.83	29.72	30.00
PARZIALI TERRENO		22.50	1.81	1.14	0.59	0.70	1.15		9.32		6.64		15.89	
QUOTE TERRENO	13.02		12.83	12.81	12.49	12.73	12.75	12.97			12.93	12.87	12.57	12.55
PROGRESSIVE PROGETTO								-2.30	-1.00	0.00				
PARZIALI PROGETTO								1.30	1.00	4.00	1.86			
QUOTE PROGETTO								18.41	18.45	18.42	18.32	18.28		
PROGRESSIVE RILEVATO								-2.30	-2.30	-1.00	0.00		5.86	5.86
PARZIALI RILEVATO								1.30	1.00	5.86				
QUOTE RILEVATO								18.08	18.12	18.09		12.94	17.95	

PROFILO SV-FINALE-CF
 SEZIONE CF-4
 PROGRESSIVA 57.86

BASE
 C1 0.93 mq.
 CEMENTATO
 CE1 1.40 mq.
 SOTTOFONDAZIONE STRADALE
 H1 5.58 mq.
 RILEVATO
 RI1 41.60 mq.
 TAPPETO DRENANTE
 a1 9.30 ml.
 BINDER
 b1 9.30 ml.
 BONIFICA
 bo1 9.30 ml.
 SCOTICO
 sc1 9.30 ml.

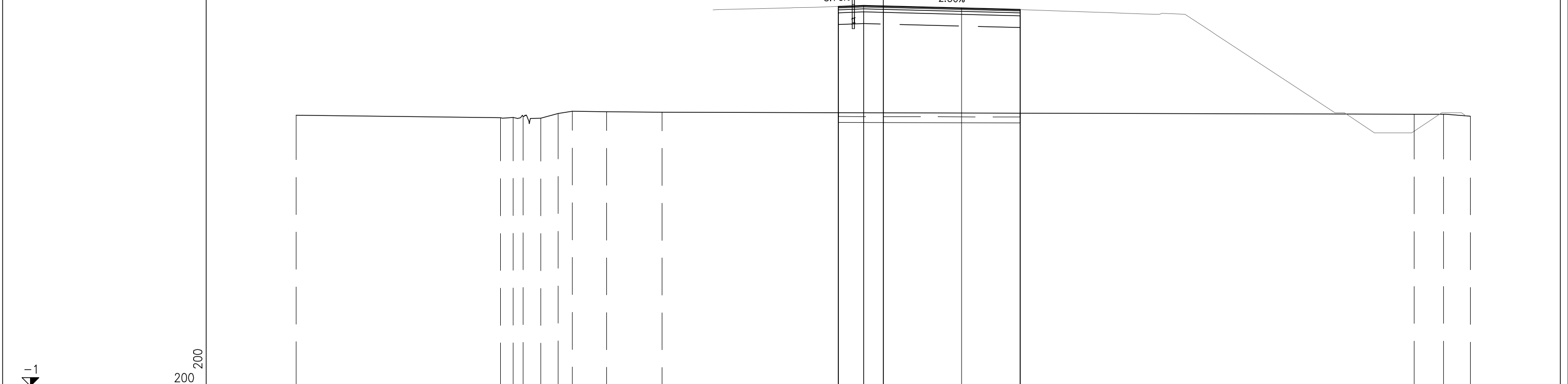

PROGRESSIVE TERRENO	-30.00	-18.56	-18.91	-18.41	-17.50	-16.61	-15.89	-14.14	-11.30	27.13	28.63	30.00	
PARZIALI TERRENO	10.44	0.65	0.50	0.91	0.89	0.72	1.75	2.84	38.43	1.50	1.37		
QUOTE TERRENO	12.85	12.72	12.73	12.79	12.70	12.94	13.05	13.03	13.01	12.90	12.90	12.80	
PROGRESSIVE PROGETTO									-2.30	-1.00	0.00	4.00	7.00
PARZIALI PROGETTO									1.30	1.00	4.00	3.00	
QUOTE PROGETTO									18.42	18.46	18.44	18.34	18.26
PROGRESSIVE RILEVATO									-2.30	-1.00	0.00	7.00	7.00
PARZIALI RILEVATO									1.30	1.00	7.00		
QUOTE RILEVATO									18.09	18.13	18.11	17.93	17.93

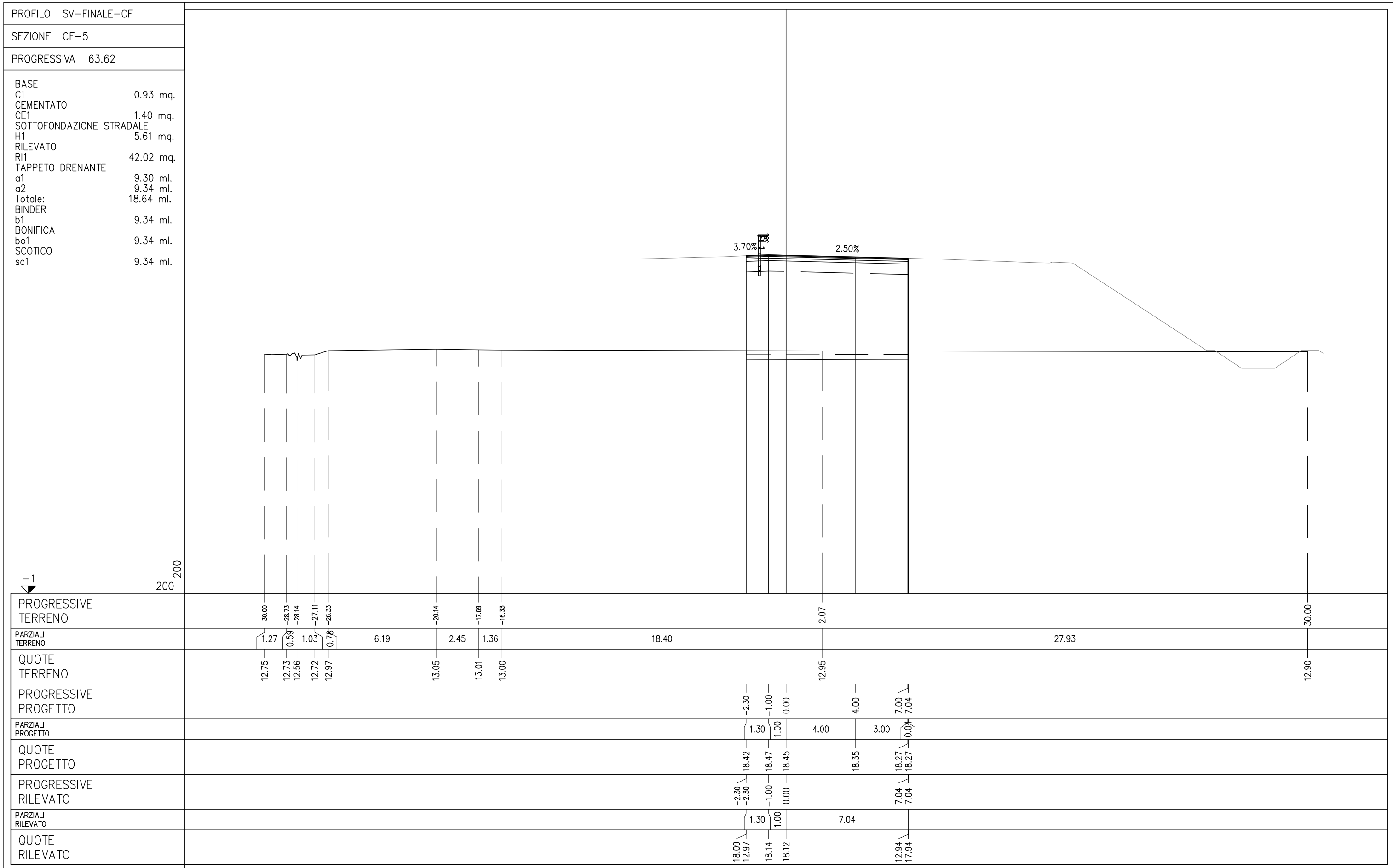

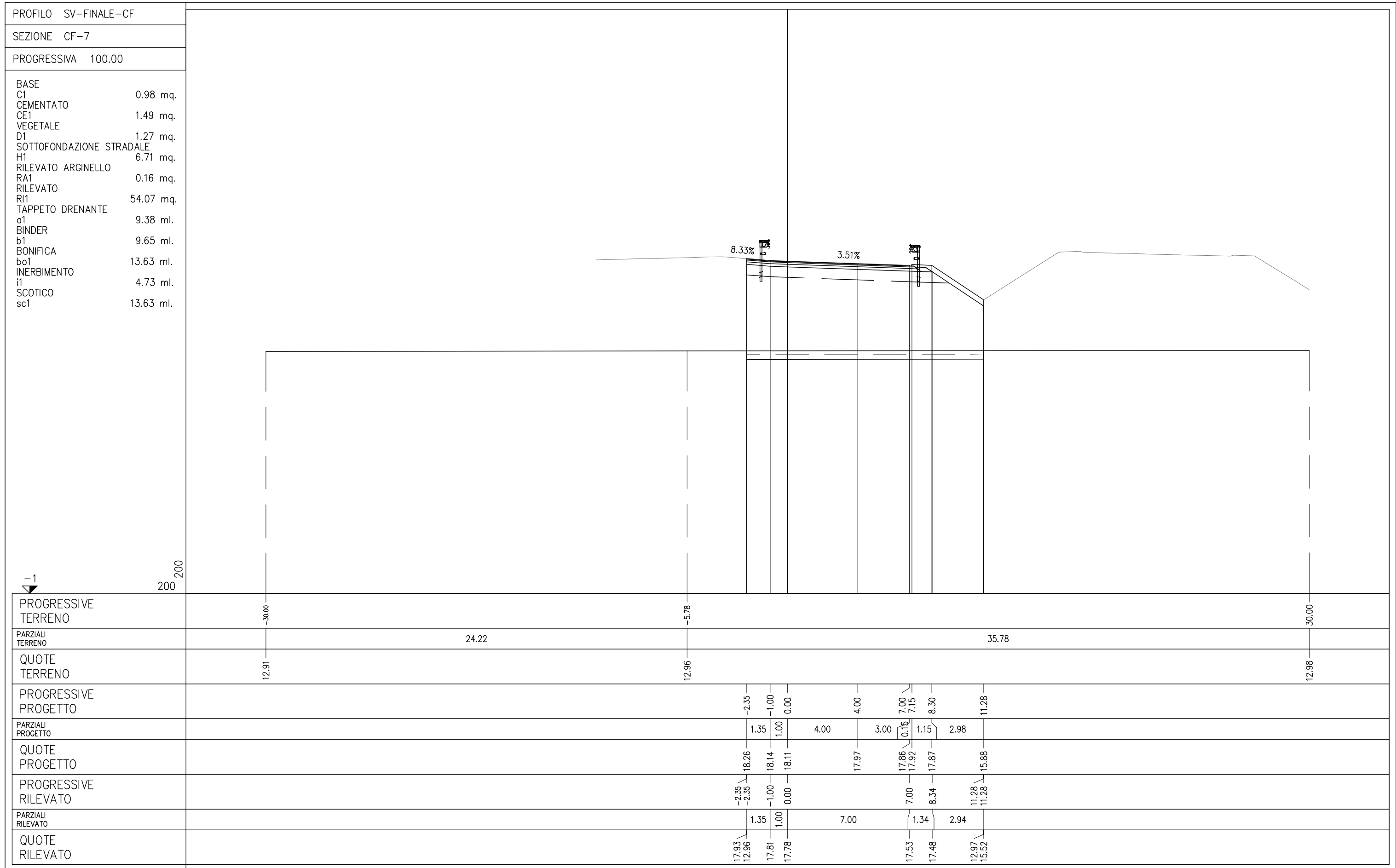

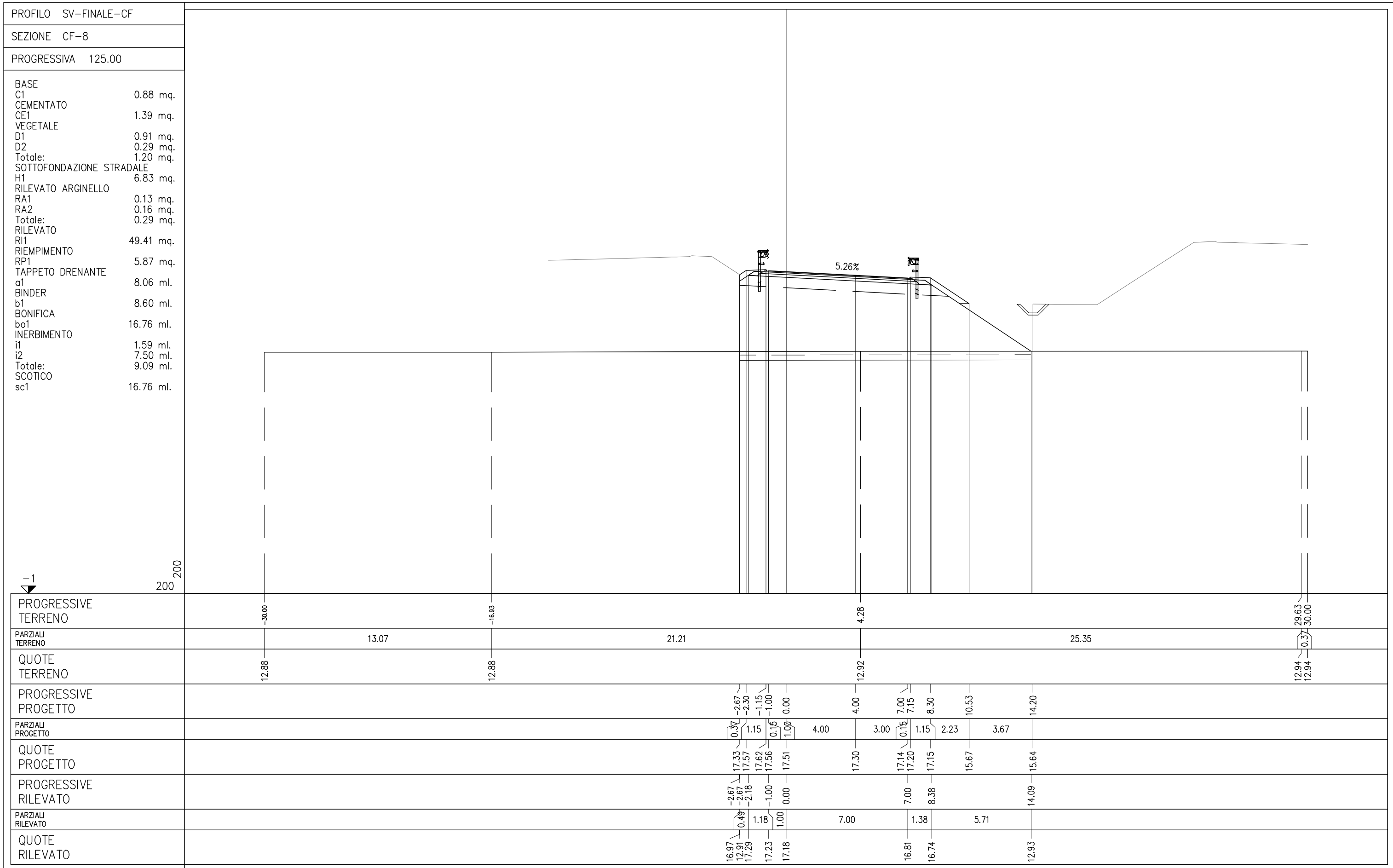

PROFILO SV-FINALE-CF

SEZIONE CF-9

PROGRESSIVA 149.80

BASE	
C1	0.91 mq.
CEMENTATO	
CE1	1.42 mq.
VEGETALE	
D1	0.65 mq.
D2	1.40 mq.
Totale:	2.05 mq.
SOTTOFONDAZIONE STRADALE	
H1	7.01 mq.
RILEVATO ARGINELLO	
RA1	0.12 mq.
RA2	0.17 mq.
Totale:	0.29 mq.
RILEVATO	
RI1	46.14 mq.
RIEMPIMENTO	
RP1	10.77 mq.
TAPPETO DRENANTE	
a1	8.32 ml.
BINDER	
b1	8.86 ml.
BONIFICA	
bo1	18.95 ml.
INERBIMENTO	
i1	8.60 ml.
i2	5.30 ml.
Totale:	13.90 ml.
SCOTICO	
sc1	18.95 ml.

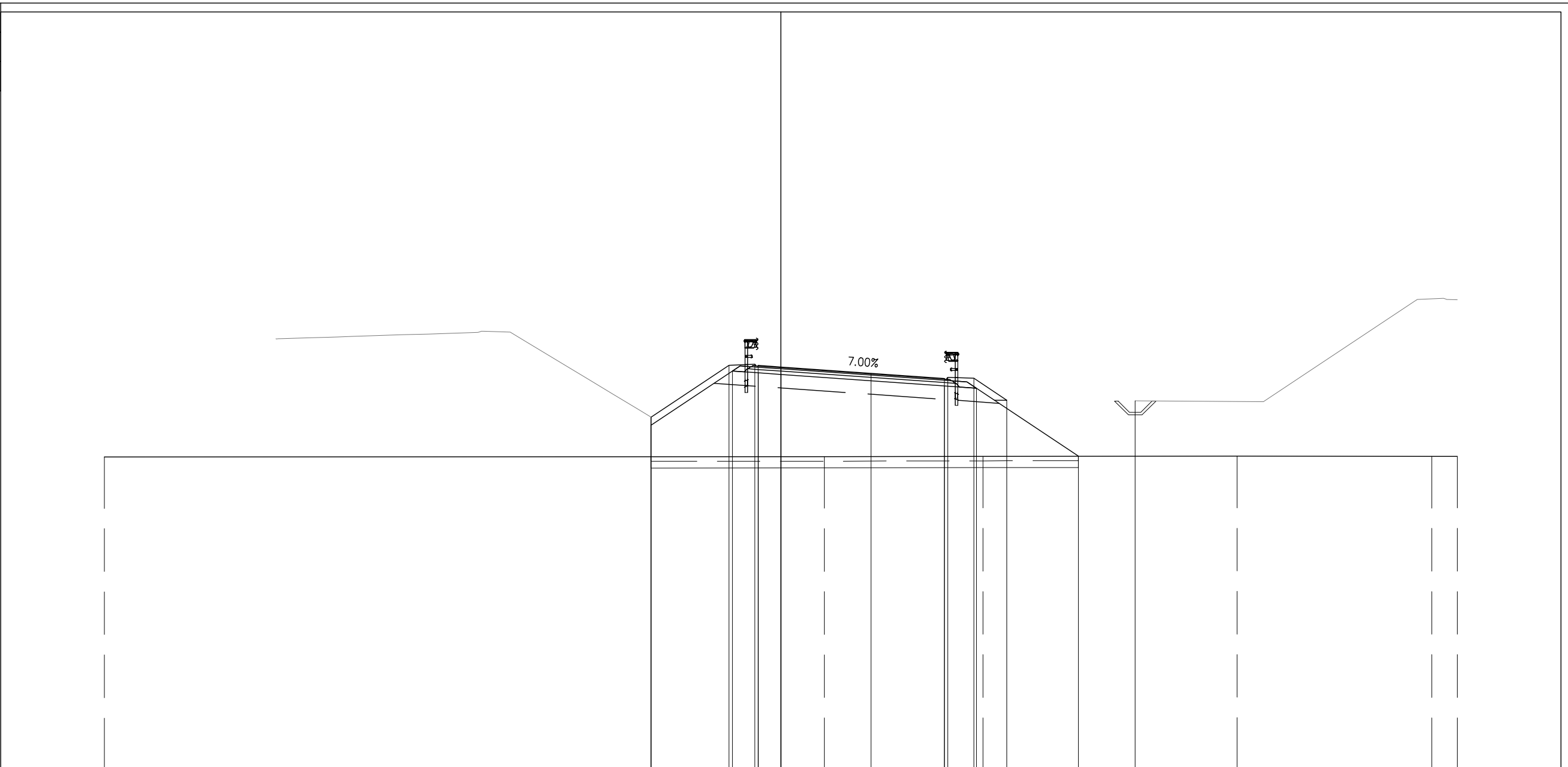

PROGRESSIVE TERRENO	-30.00		1.93		8.97		20.24		28.87	30.00					
PARZIALI TERRENO		31.93		7.04		11.27		8.63	1.13						
QUOTE TERRENO	12.86		12.87		12.89		12.90		12.89	12.89					
PROGRESSIVE PROGETTO			-5.75	-2.30	-1.15	0.00		4.00	4.00	7.26	7.41	8.56	10.02		15.71
PARZIALI PROGETTO			3.45	1.15	0.15	1.00	4.00	3.26	0.15	1.15	1.46	5.69			
QUOTE PROGETTO			14.63	16.93	16.98	16.92	16.85	16.57	16.34	16.40	16.35	15.37		15.35	
PROGRESSIVE RILEVATO			-5.75	-2.15	-1.00	0.00		7.26	7.26	8.68		13.20			
PARZIALI RILEVATO			3.60	1.15	1.00		7.26	1.42		4.52		13.20			
QUOTE RILEVATO			14.27	16.67	16.59	16.52		16.01	15.91			12.89			

PROFILO SV-FINALE-CF
 SEZIONE CF-10
 PROGRESSIVA 175.00

BASE	
C1	0.87 mq.
CEMENTATO	
CE1	1.38 mq.
VEGETALE	
D1	0.46 mq.
D2	1.94 mq.
Totale:	2.40 mq.
SOTTOFONDAZIONE STRADALE	
H1	6.89 mq.
RILEVATO ARGINELLO	
RA1	0.13 mq.
RA2	0.18 mq.
Totale:	0.31 mq.
RILEVATO	
RI1	35.92 mq.
RIEMPIMENTO	
RP1	10.27 mq.
SCAVO FOSSI	
SF1	3.01 mq.
RILEVATO FOSSI	
VF1	0.64 mq.
TAPPETO DRENANTE	
a1	8.06 ml.
BINDER	
b1	8.60 ml.
BONIFICA	
bo1	19.12 ml.
INERBIMENTO	
i1	8.02 ml.
i2	7.27 ml.
Totale:	15.29 ml.
SCOTICO	
sc2	19.12 ml.
SCOTICO FOSSI	
sf1	6.12 ml.

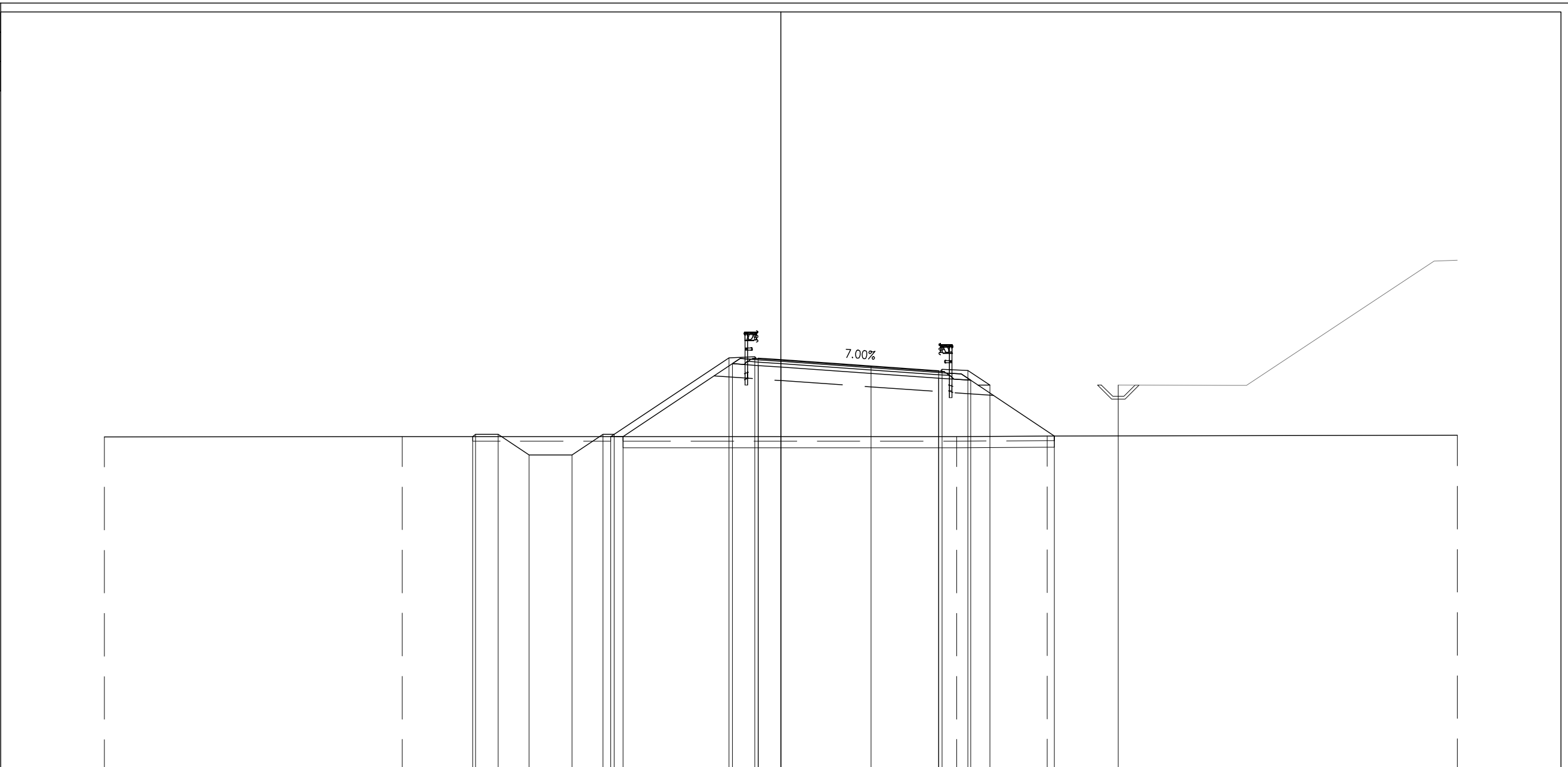

PROGRESSIVE TERRENO	-30.00	-16.79	7.79	11.81	30.00
PARZIALI TERRENO	13.21	24.58	4.02	18.19	
QUOTE TERRENO	12.74	12.77	12.76	12.79	12.83
PROGRESSIVE PROGETTO					
PARZIALI PROGETTO					
QUOTE PROGETTO					
PROGRESSIVE RILEVATO					
PARZIALI RILEVATO					
QUOTE RILEVATO					

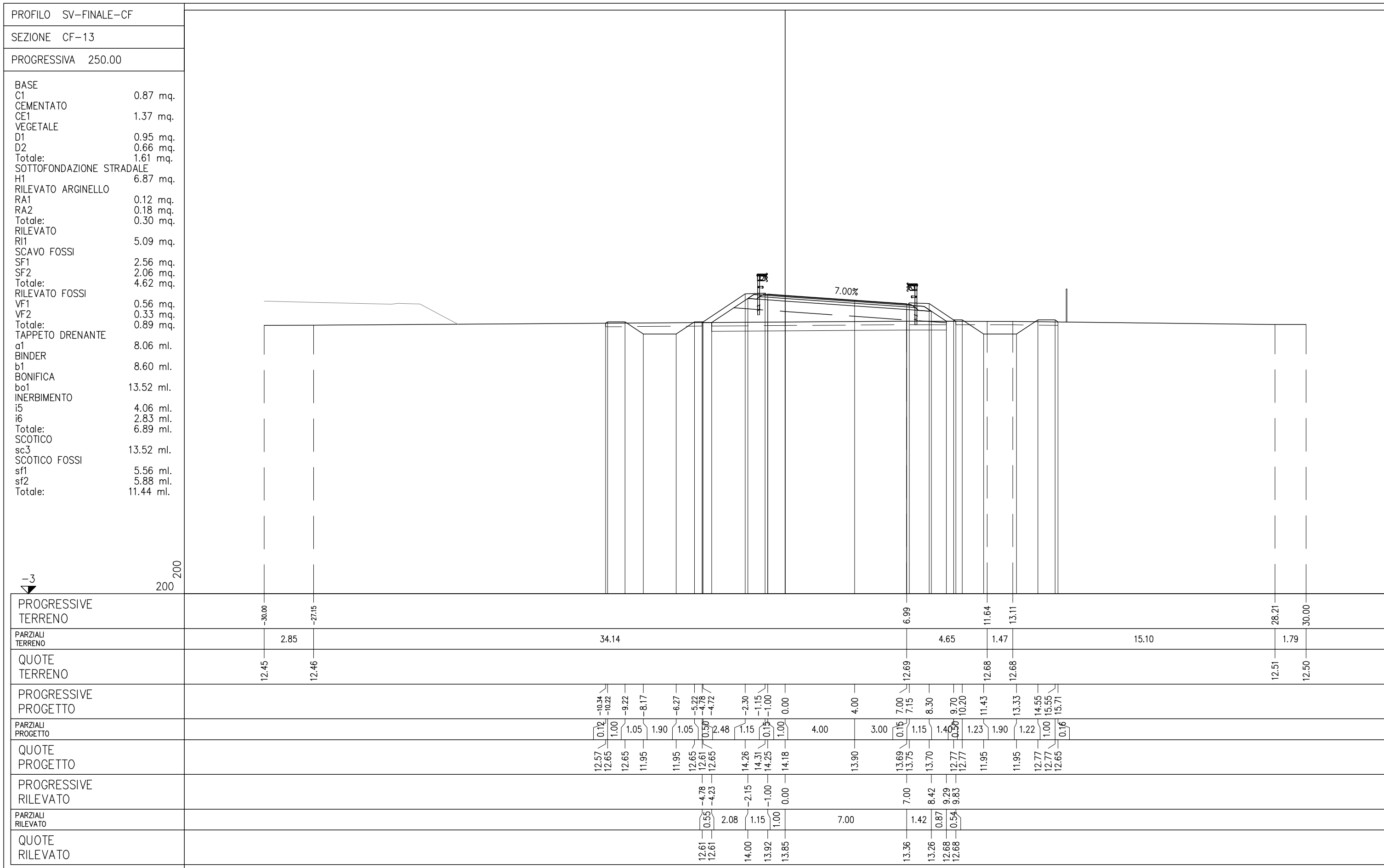

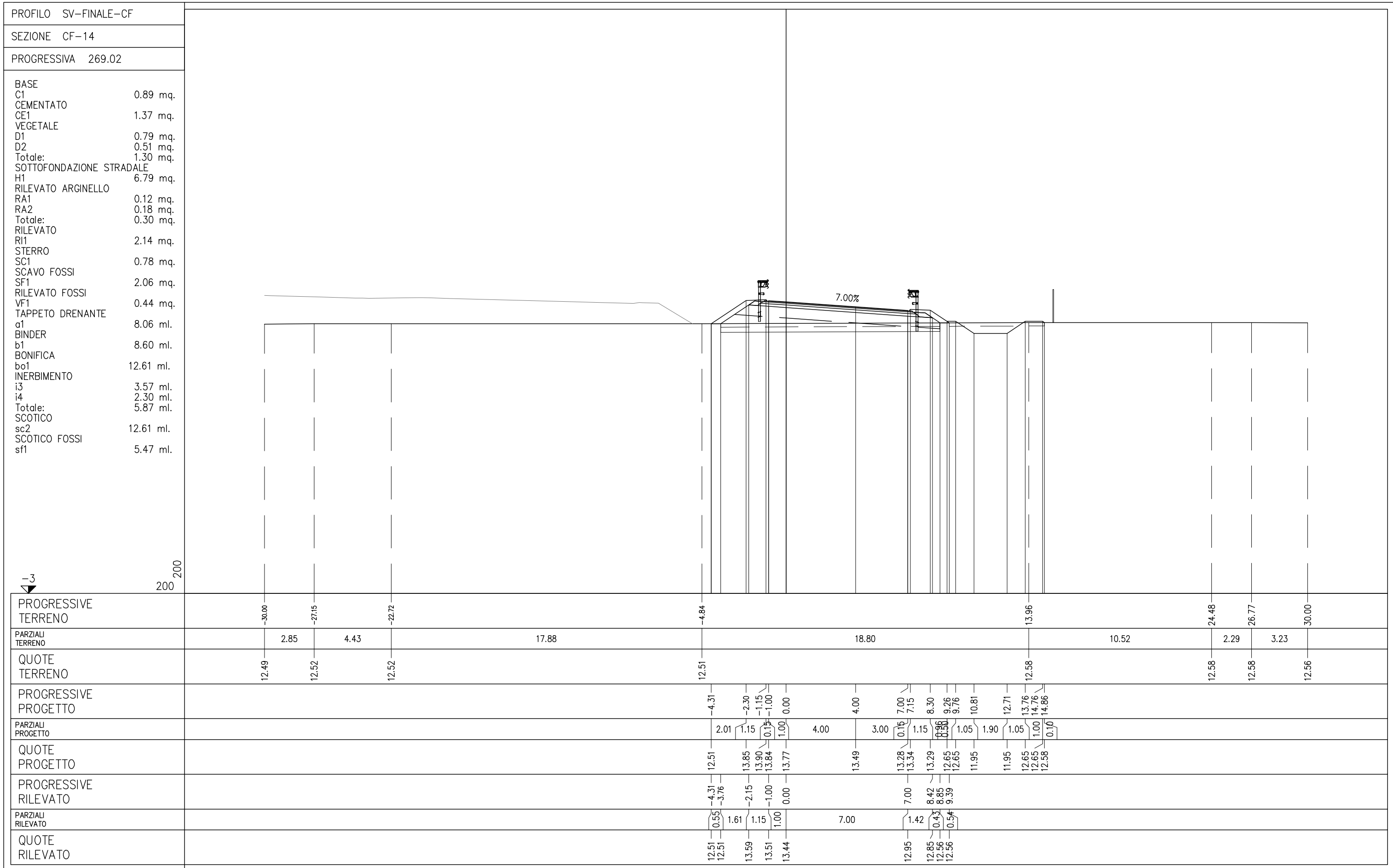

PROFILO SV-FINALE-CF

SEZIONE CF-15

PROGRESSIVA 300.00

- BASE
- C1 0.74 mq.
- CEMENTATO
- CE1 1.13 mq.
- VEGETALE
- D1 0.46 mq.
- SOTTOFONDAZIONE STRADALE
- H1 5.23 mq.
- RILEVATO ARGINELLO
- RA1 0.17 mq.
- RILEVATO
- RI1 0.17 mq.
- STERRO
- SC1 1.11 mq.
- SCAVO FOSSI
- SF1 3.04 mq.
- RILEVATO FOSSI
- VF1 0.66 mq.
- TAPPETO DRENANTE
- a1 7.03 ml.
- BINDER
- b1 7.30 ml.
- BONIFICA
- bo1 8.79 ml.
- INERBIMENTO
- i3 2.17 ml.
- SCOTICO
- sc2 8.79 ml.
- SCOTICO FOSSI
- sf1 6.12 ml.

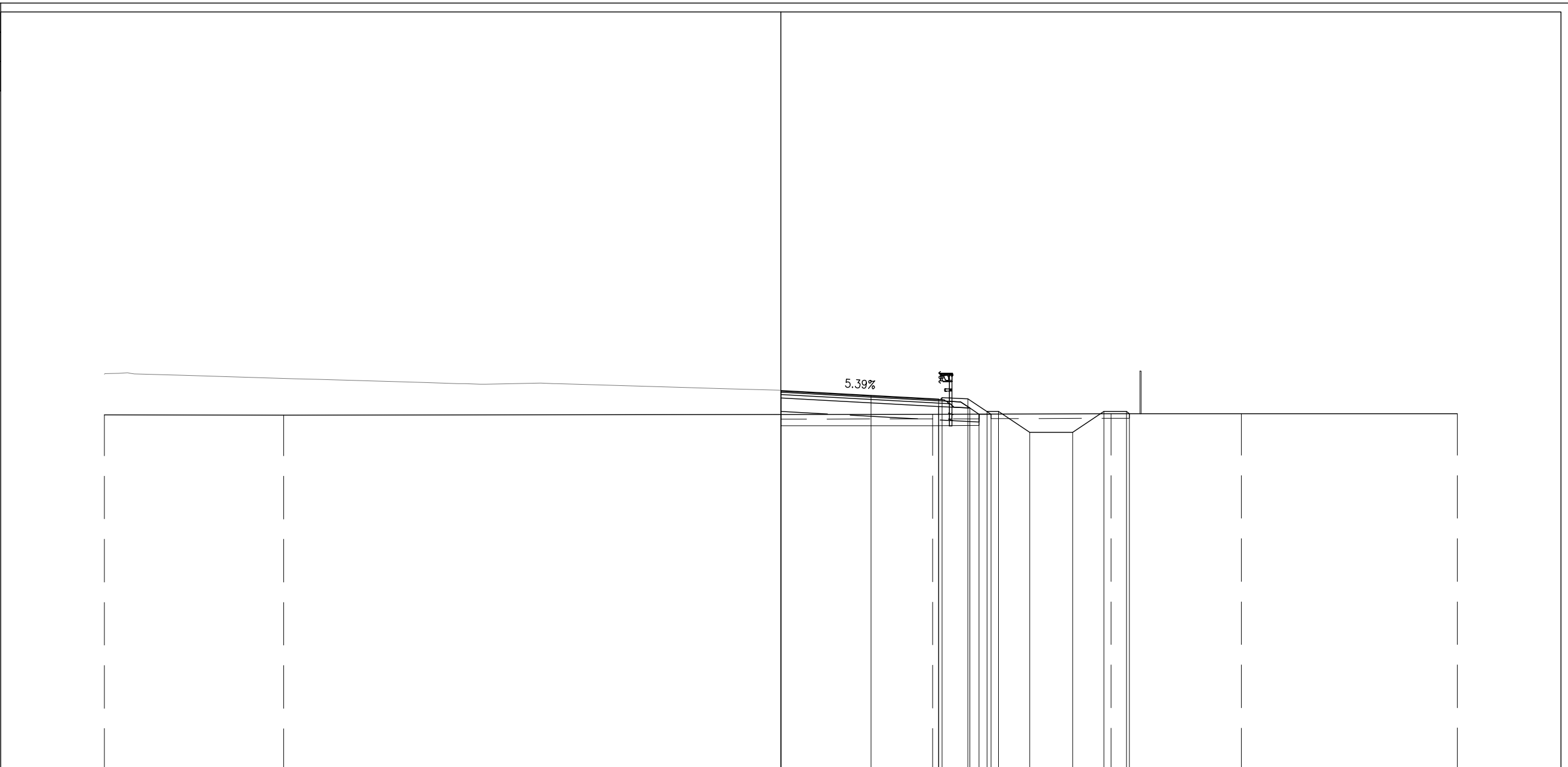

PROGRESSIVE TERRENO	-30.00	-22.05		6.73	14.65	20.42	30.00							
PARZIALI TERRENO		7.95	28.78	7.92	5.77	9.58								
QUOTE TERRENO	12.73	12.72		12.75	12.78	12.78	12.78							
PROGRESSIVE PROGETTO			0.00	4.00	7.00	7.15	8.30	9.15	9.65	11.04	12.94	14.33	15.33	15.45
PARZIALI PROGETTO				4.00	3.00	0.15	1.15	0.85	0.50	1.39	1.90	1.39	1.00	0.12
QUOTE PROGETTO			13.81	13.59	13.43	13.49	13.44	12.88	12.88	11.95	11.95	12.88	12.88	12.78
PROGRESSIVE RILEVATO			0.00	0.00	7.00	8.38	8.79	9.33						
PARZIALI RILEVATO				7.00	1.38	0.41	0.54							
QUOTE RILEVATO	13.48	12.74			13.10	13.03	12.76	12.76						

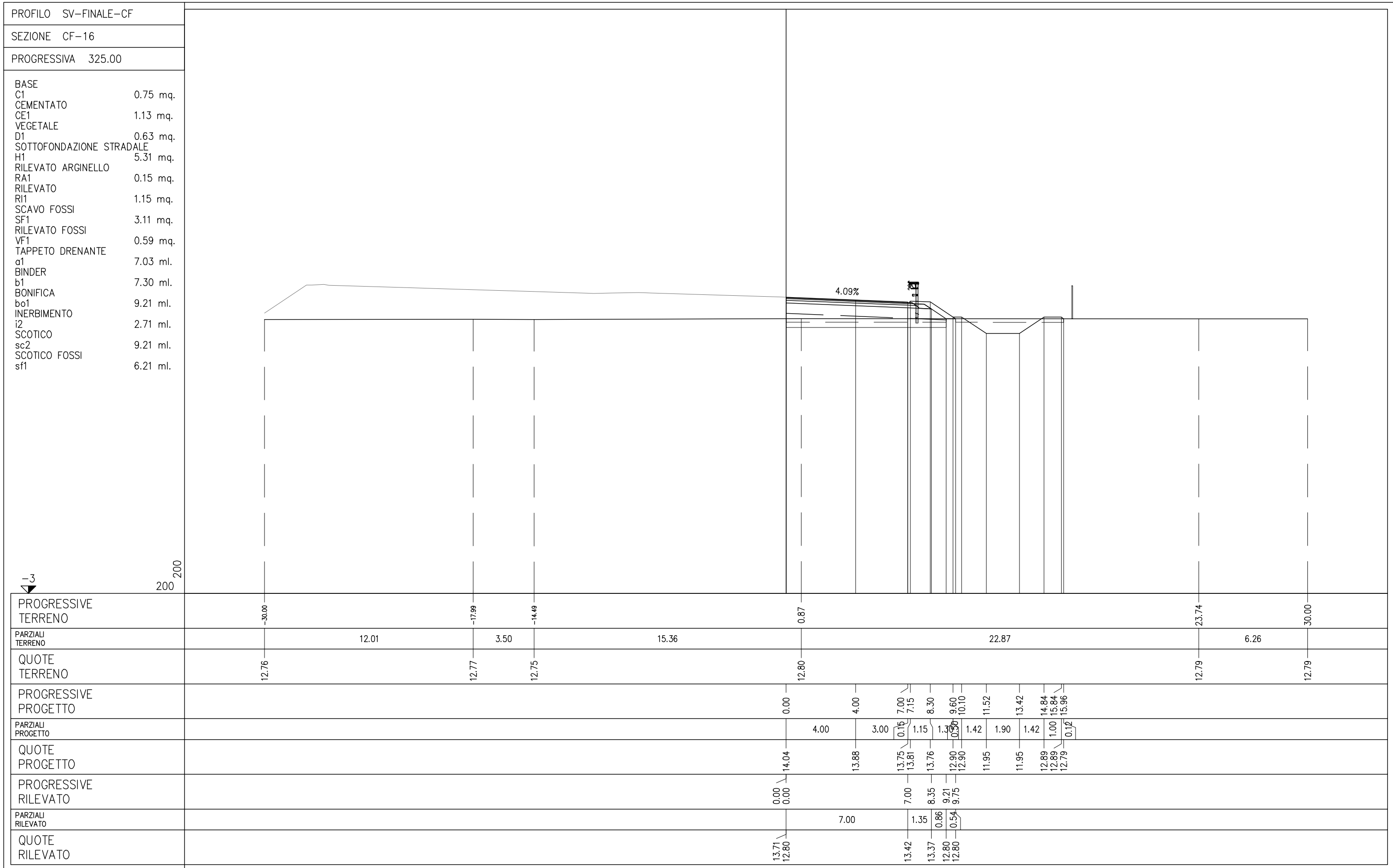

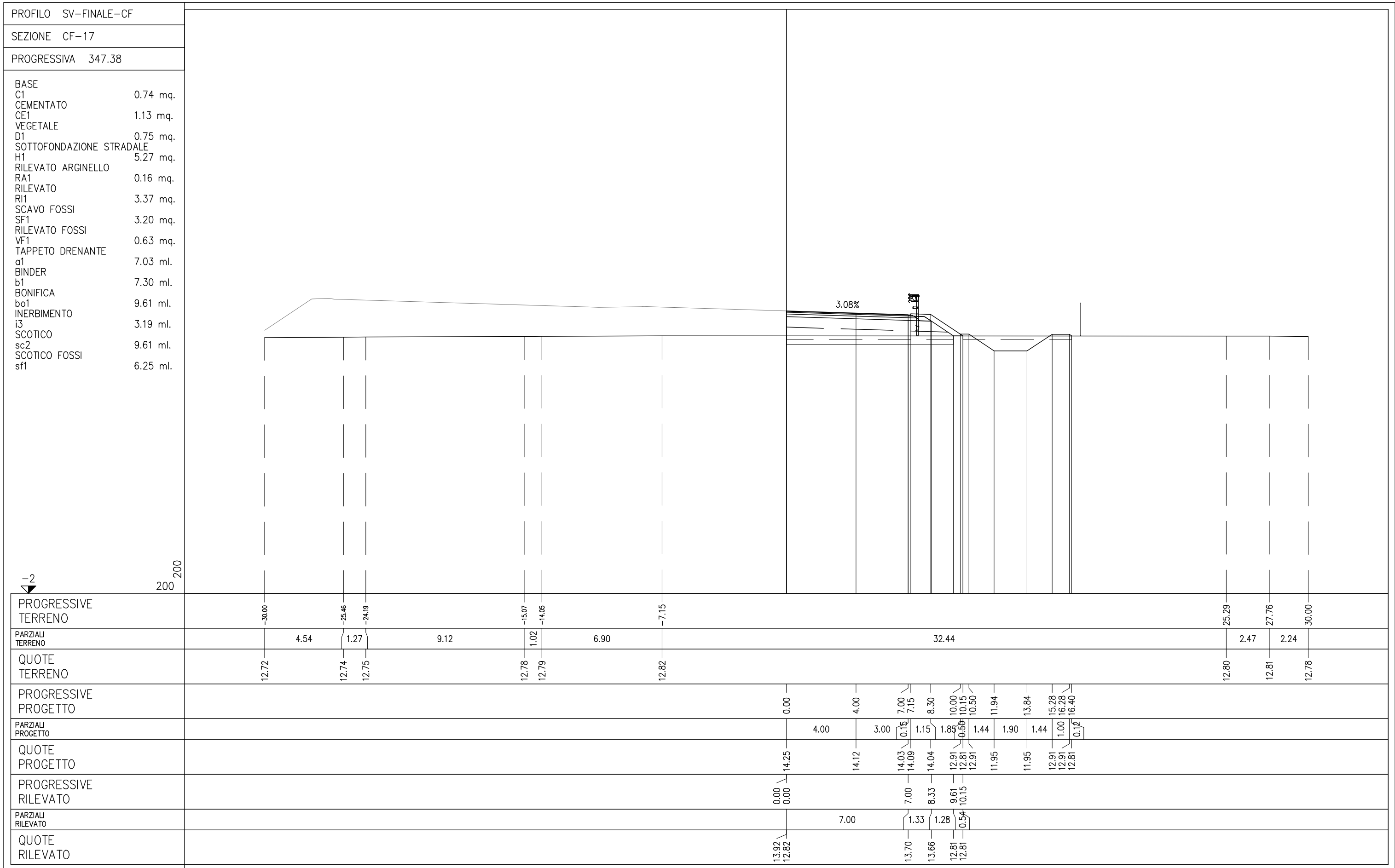

SVINCOLO DI SAN FELICE SUL PANARO - FINALE EMILIA
RAMO CR
SRA11

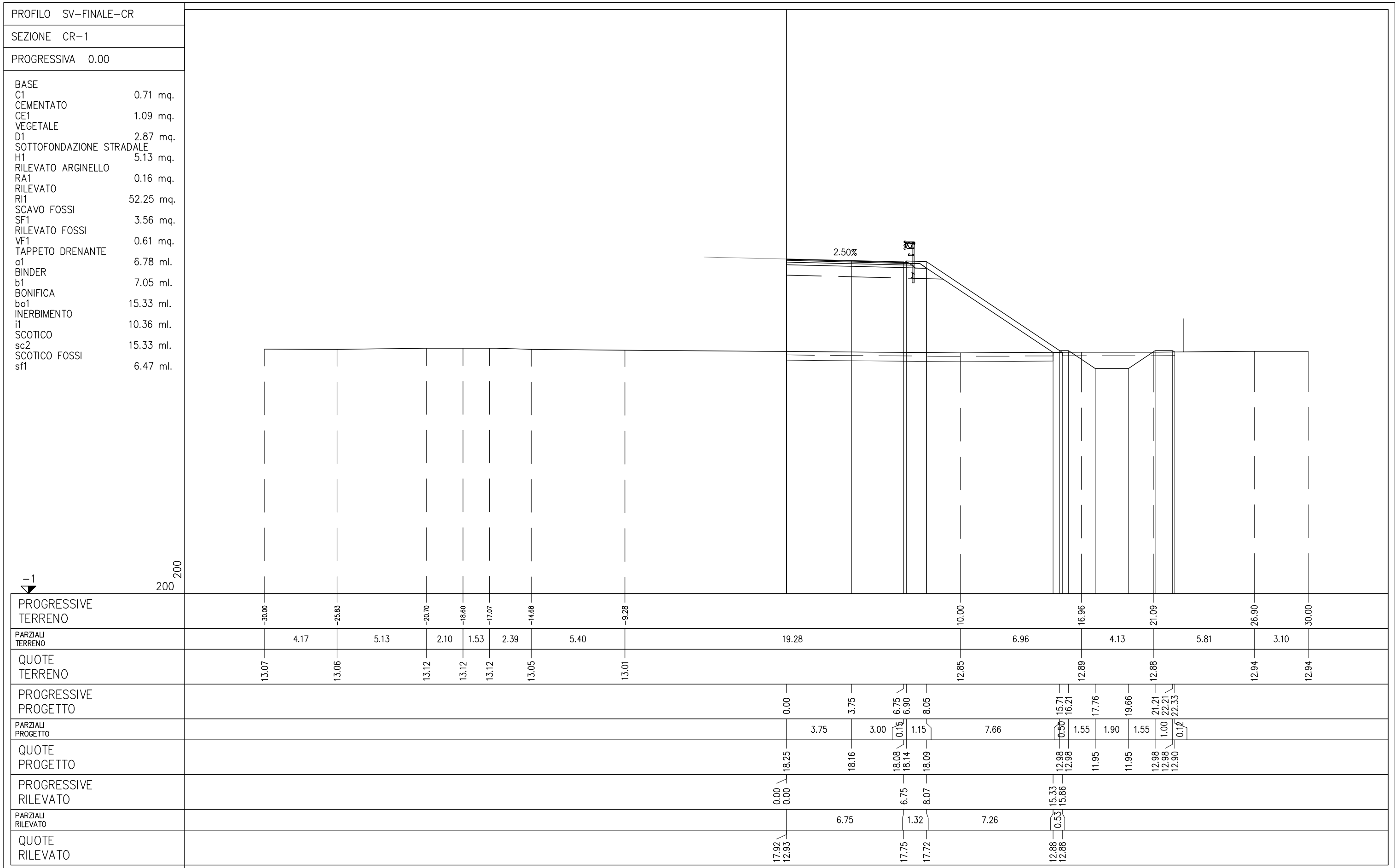

PROFILO SV-FINALE-CR

SEZIONE CR-3

PROGRESSIVA 25.00

- BASE 0.74 mq.
- C1
- CEMENTATO 1.11 mq.
- CE1
- VEGETALE
- D1 2.90 mq.
- SOTTOFONDAZIONE STRADALE
- H1 5.22 mq.
- RILEVATO ARGINELLO
- RA1 0.16 mq.
- RILEVATO
- RI1 52.79 mq.
- SCAVO FOSSI
- SF1 3.49 mq.
- RILEVATO FOSSI
- VF1 0.75 mq.
- TAPPETO DRENANTE
- a1 6.92 ml.
- BINDER
- b1 7.19 ml.
- BONIFICA
- bo1 15.50 ml.
- INERBIMENTO
- i1 10.31 ml.
- SCOTICO
- sc2 15.50 ml.
- SCOTICO FOSSI
- sf1 6.34 ml.

-1
200
200

PROGRESSIVE TERRENO	-30.00	-25.79	-20.93		-8.99	-7.53	-2.61		11.92	13.50	14.31		25.31	26.06	30.00
PARZIALI TERRENO		4.21	4.86		11.94	1.46	4.92		14.53	1.58	0.81		11.00	0.75	3.94
QUOTE TERRENO	13.17	13.14	13.11		12.97	12.93	12.92		12.83	12.83	12.80		12.91	12.91	12.91
PROGRESSIVE PROGETTO								0.00	3.89	3.00	6.89	7.04	8.19		
PARZIALI PROGETTO										3.89	3.00	0.15	1.15		7.62
QUOTE PROGETTO								18.25	18.13	18.04	18.09	18.05			
PROGRESSIVE RILEVATO								0.00	0.00	0.00			15.50	16.03	
PARZIALI RILEVATO													0.53	0.50	
QUOTE RILEVATO								17.92	17.90	17.92			17.71	17.67	

3.05%

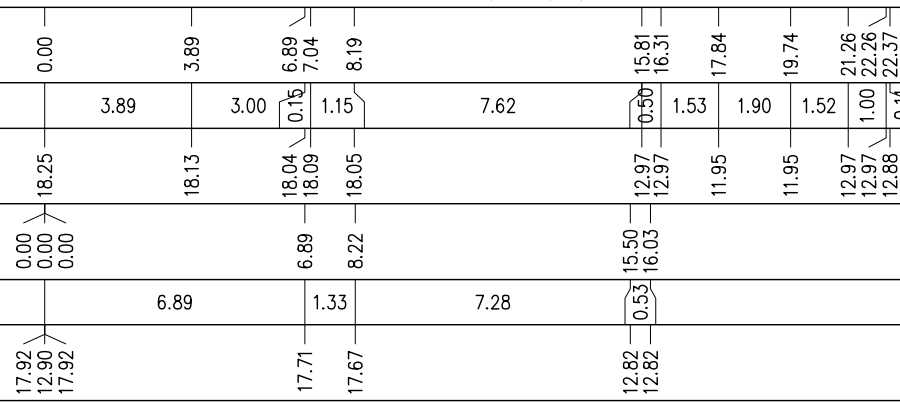

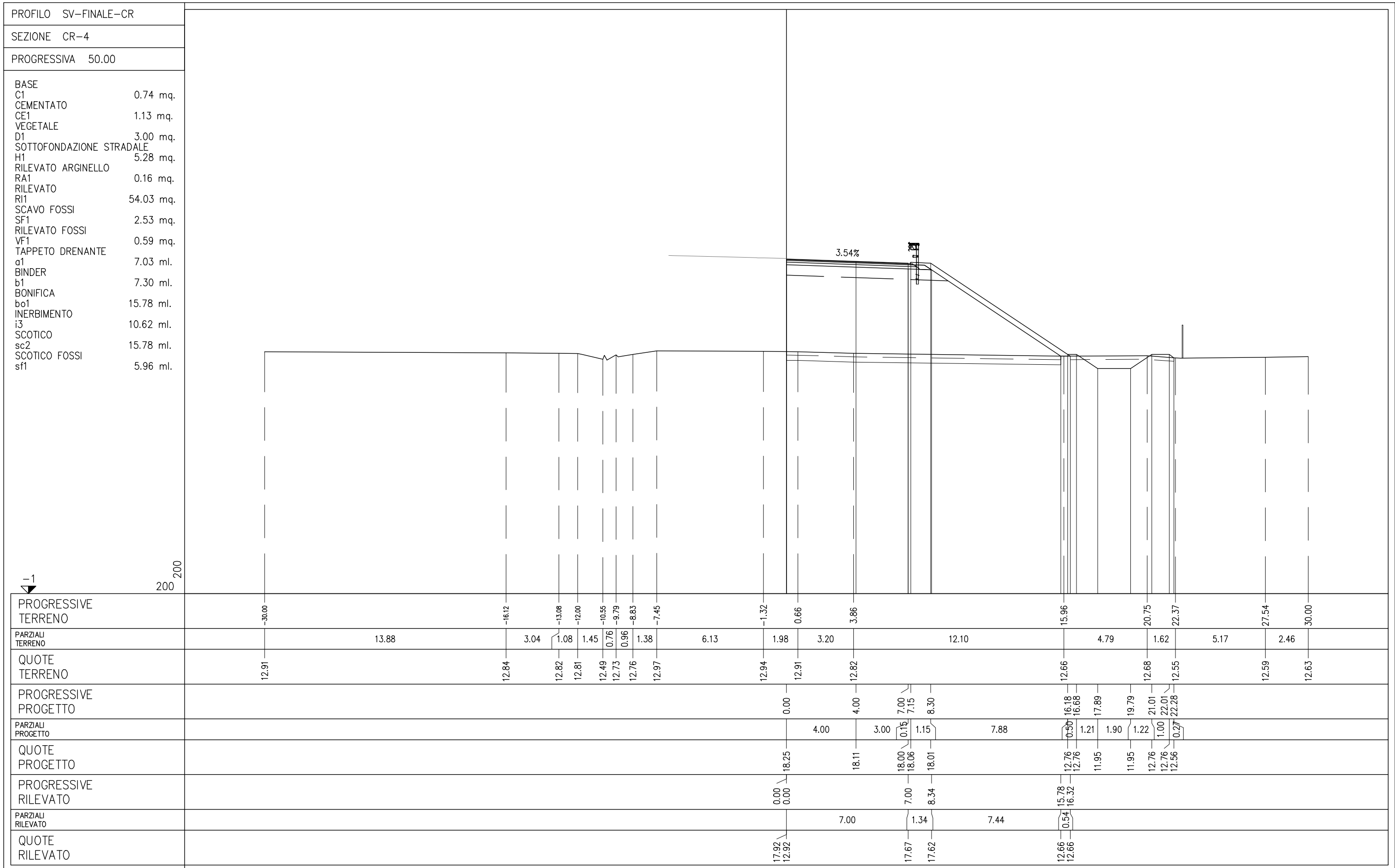

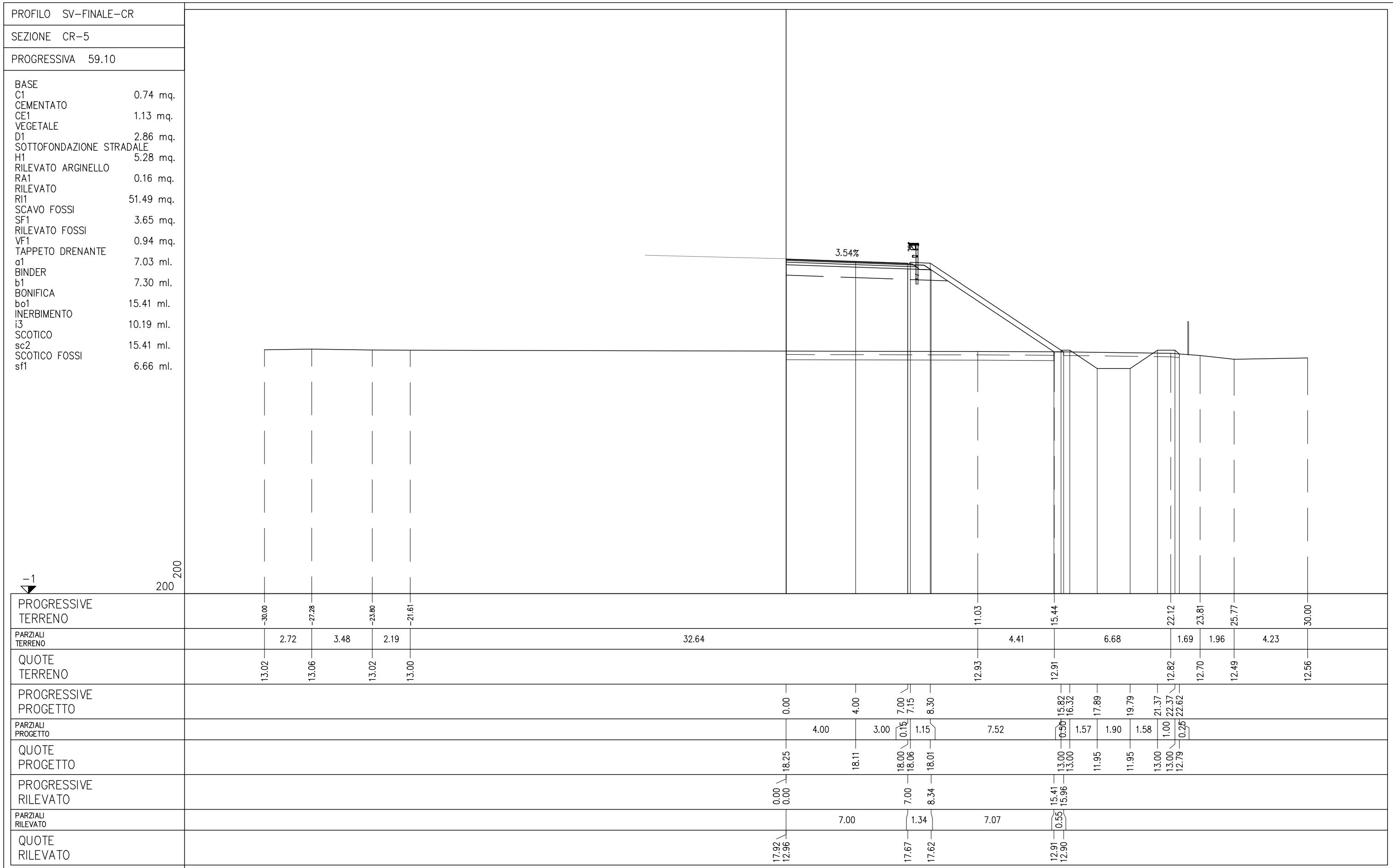

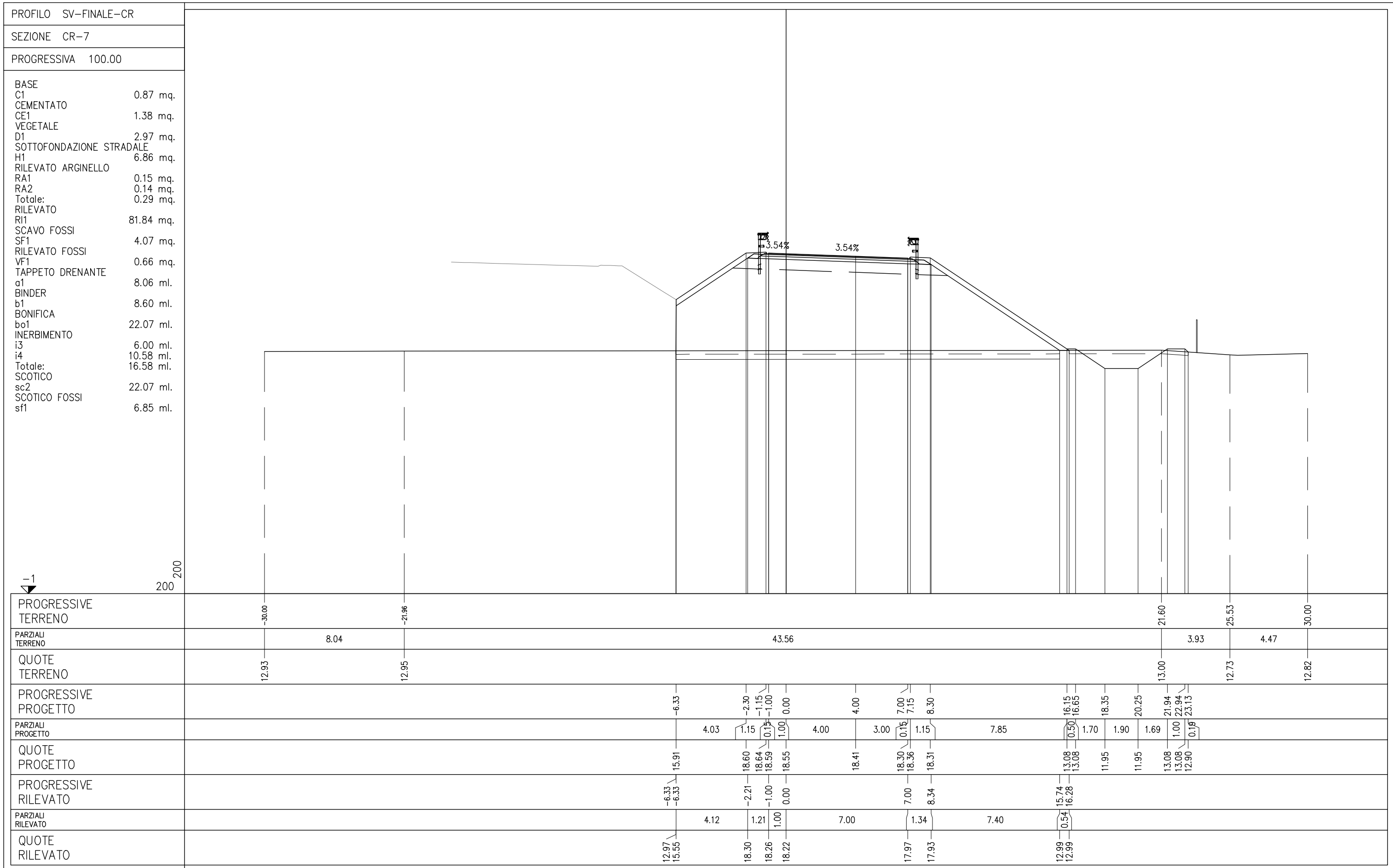

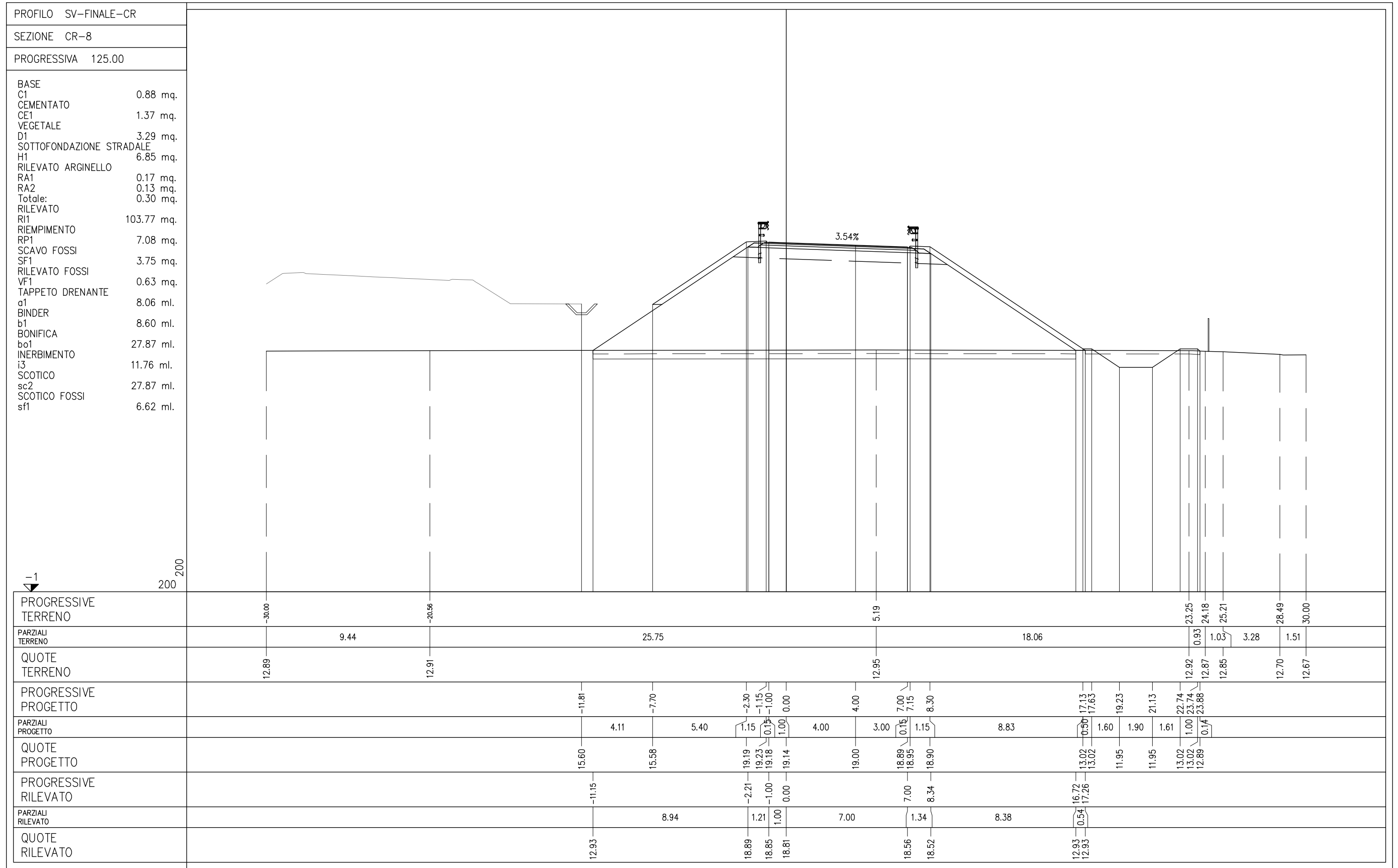

PROFILO SV-FINALE-CR

SEZIONE CR-9

PROGRESSIVA 151.43

BASE	
C1	0.88 mq.
CEMENTATO	
CE1	1.38 mq.
VEGETALE	
D1	2.76 mq.
D2	3.86 mq.
Totale:	6.62 mq.
SOTTOFONDAZIONE STRADALE	
H1	6.88 mq.
RILEVATO ARGINELLO	
RA1	0.16 mq.
RA2	0.13 mq.
Totale:	0.29 mq.
RILEVATO	
RI1	133.44 mq.
RIEMPIMENTO	
RP1	11.18 mq.
SCAVO FOSSI	
SF1	3.64 mq.
RILEVATO FOSSI	
VF1	0.65 mq.
TAPPETO DRENANTE	
a1	8.06 ml.
BINDER	
b1	8.60 ml.
BONIFICA	
bo1	30.88 ml.
INERBIMENTO	
i3	16.10 ml.
i4	13.54 ml.
Totale:	29.64 ml.
SCOTICO	
sc2	30.88 ml.
SCOTICO FOSSI	
sf1	6.47 ml.

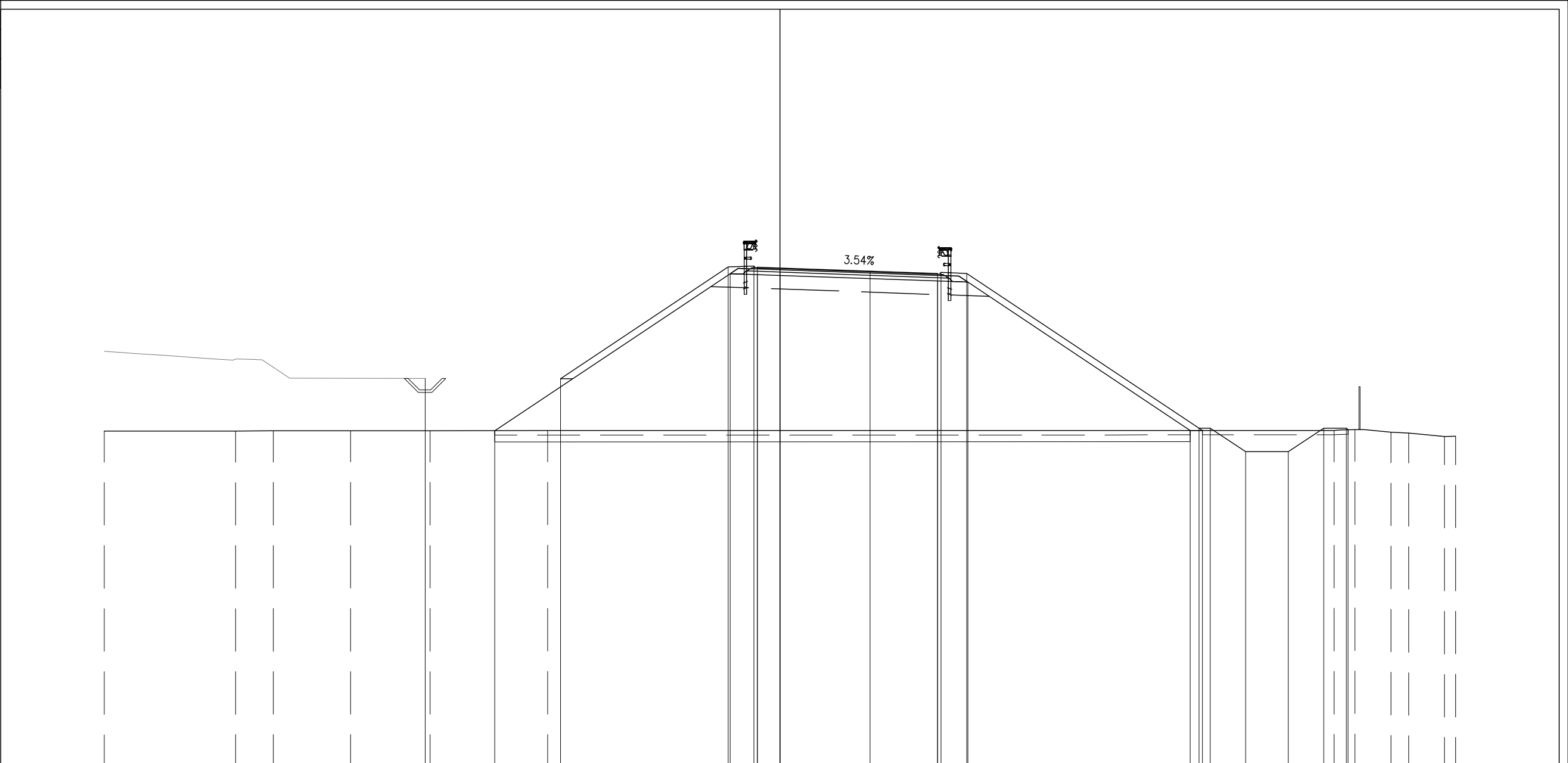

PROGRESSIVE TERRENO	-30.00	-24.17	-22.49	-19.06	-15.54	-10.32										24.60	25.53	27.13	27.92	29.50	30.00	
PARZIALI TERRENO		5.83	1.68	3.43	3.52	5.22				34.92						0.93	1.60	0.79	1.58	0.50		
QUOTE TERRENO	12.87	12.87	12.88	12.88	12.88	12.89										12.90	12.93	12.82	12.78	12.62	12.64	
PROGRESSIVE PROGETTO					-15.75	-9.75					-2.30	-1.15	-1.00	0.00								
PARZIALI PROGETTO					6.00	7.45					1.15	0.15	1.00	4.00	3.00	7.00	7.15	10.31				
QUOTE PROGETTO					15.20	15.19					20.15	20.20	20.14	20.11	19.96	19.86	19.91	13.00	13.00	11.95	11.95	
PROGRESSIVE RILEVATO					-12.66						-2.21	-1.00	0.00									
PARZIALI RILEVATO						10.45					1.21	1.00		7.00	1.34			9.88				
QUOTE RILEVATO					12.88						19.85	19.81	19.78			19.53	19.48	12.90	12.90			

PROFILO SV-FINALE-CR
 SEZIONE CR-11
 PROGRESSIVA 190.80

- BASE
- C1 0.80 mq.
- CEMENTATO
- CE1 1.20 mq.
- SOTTOFONDAZIONE STRADALE
- H1 4.80 mq.
- RILEVATO
- RI2 68.29 mq.
- TAPPETO DRENANTE
- a1 8.00 ml.
- BINDER
- b1 8.00 ml.
- BONIFICA
- bo1 8.00 ml.
- SCOTICO
- sc1 8.00 ml.

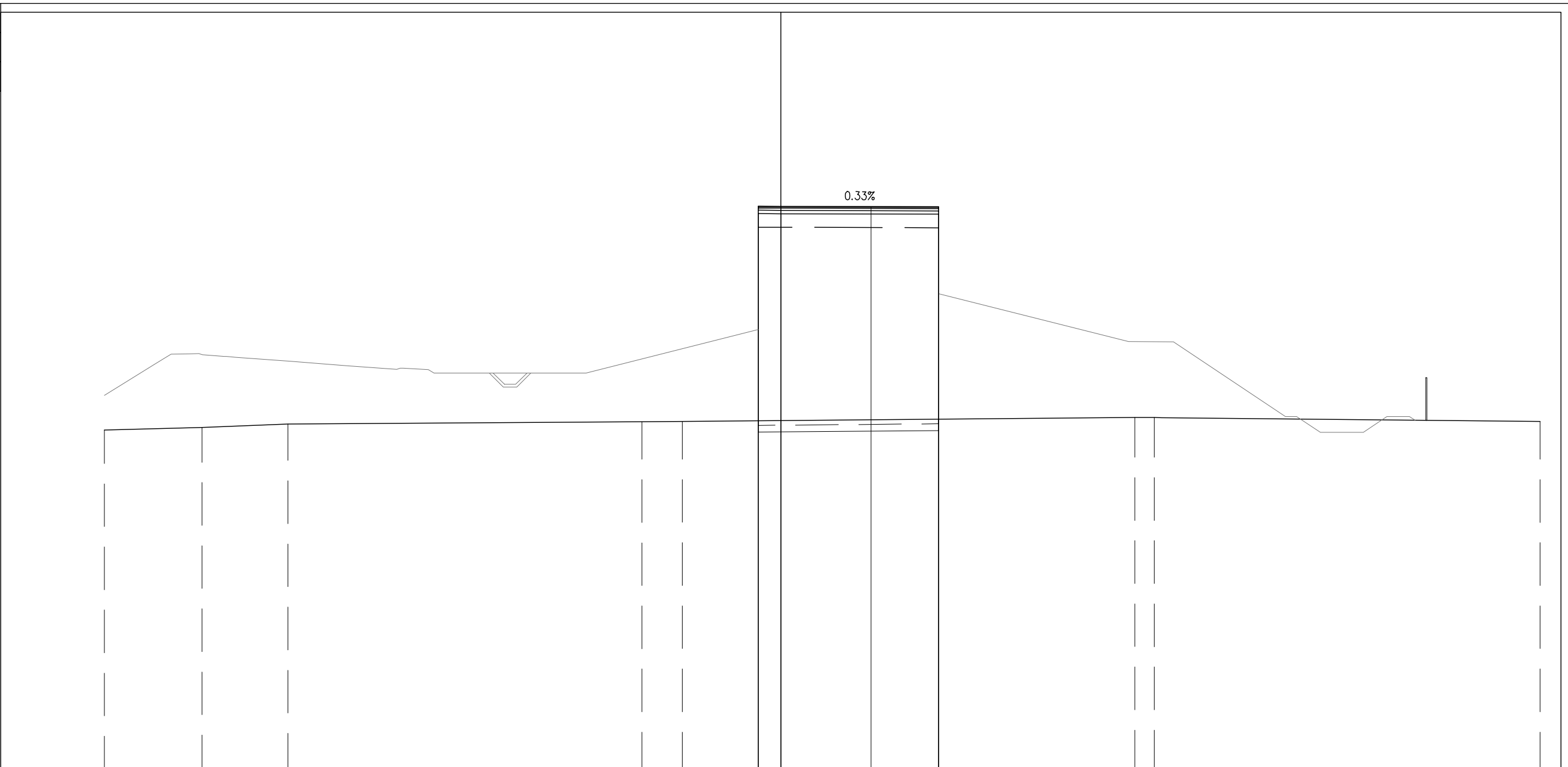

PROGRESSIVE TERRENO	-30.00	-25.66	-21.86	-6.15	-4.36	15.70	16.57	33.67	
PARZIALI TERRENO	4.34	3.80	15.71	1.79	20.06	0.87	17.10		
QUOTE TERRENO	12.08	12.18	12.34	12.44	12.45	12.62	12.62	12.45	
PROGRESSIVE PROGETTO						-1.00	0.00	4.00	7.00
PARZIALI PROGETTO						1.00	4.00	3.00	
QUOTE PROGETTO						21.98	21.99	21.97	
PROGRESSIVE RILEVATO						-1.00	0.00	7.00	7.00
PARZIALI RILEVATO						1.00	7.00		
QUOTE RILEVATO						21.67	21.66	21.64	

PROFILO SV-FINALE-CR

SEZIONE CR-12SPA

PROGRESSIVA 191.51

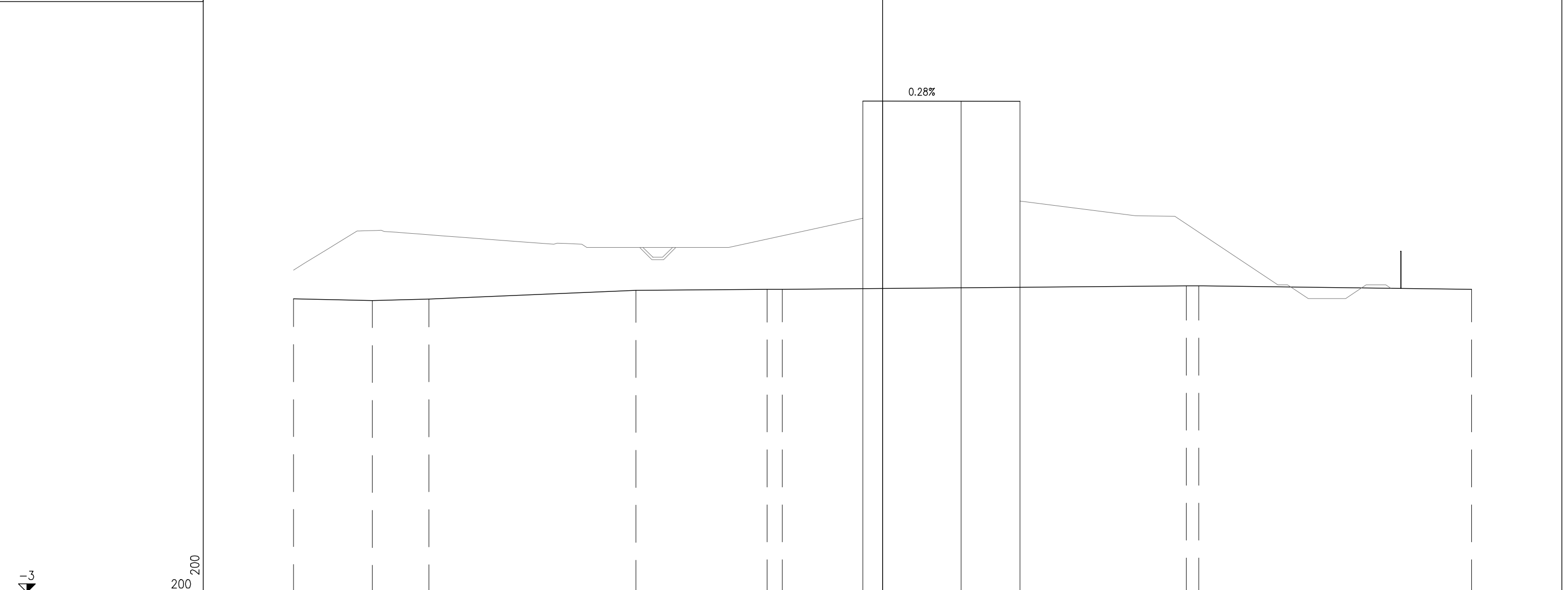

PROGRESSIVE TERRENO	-30.00	-25.98	-23.11	-12.56	-5.88	-5.10	15.47	30.00
PARZIALI TERRENO	4.02	2.87	10.55	6.68	0.78	20.57	0.64	13.89
QUOTE TERRENO	11.96	11.87	11.94	12.39	12.44	12.44	12.62	12.44
PROGRESSIVE PROGETTO								
PARZIALI PROGETTO								
QUOTE PROGETTO								
PROGRESSIVE RILEVATO								
PARZIALI RILEVATO								
QUOTE RILEVATO								

PROFILO SV-FINALE-CR
 SEZIONE CR-22
 PROGRESSIVA 320.03

- BASE 0.84 mq.
- C1 CEMENTATO 1.23 mq.
- CE1 SOTTOFONDAZIONE STRADALE 4.97 mq.
- H1 RILEVATO 91.38 mq.
- RI1 TAPPETO DRENANTE a1 8.27 ml.
- BINDER b1 8.27 ml.
- BONIFICA bo1 8.27 ml.
- SCOTICO sc1 8.27 ml.

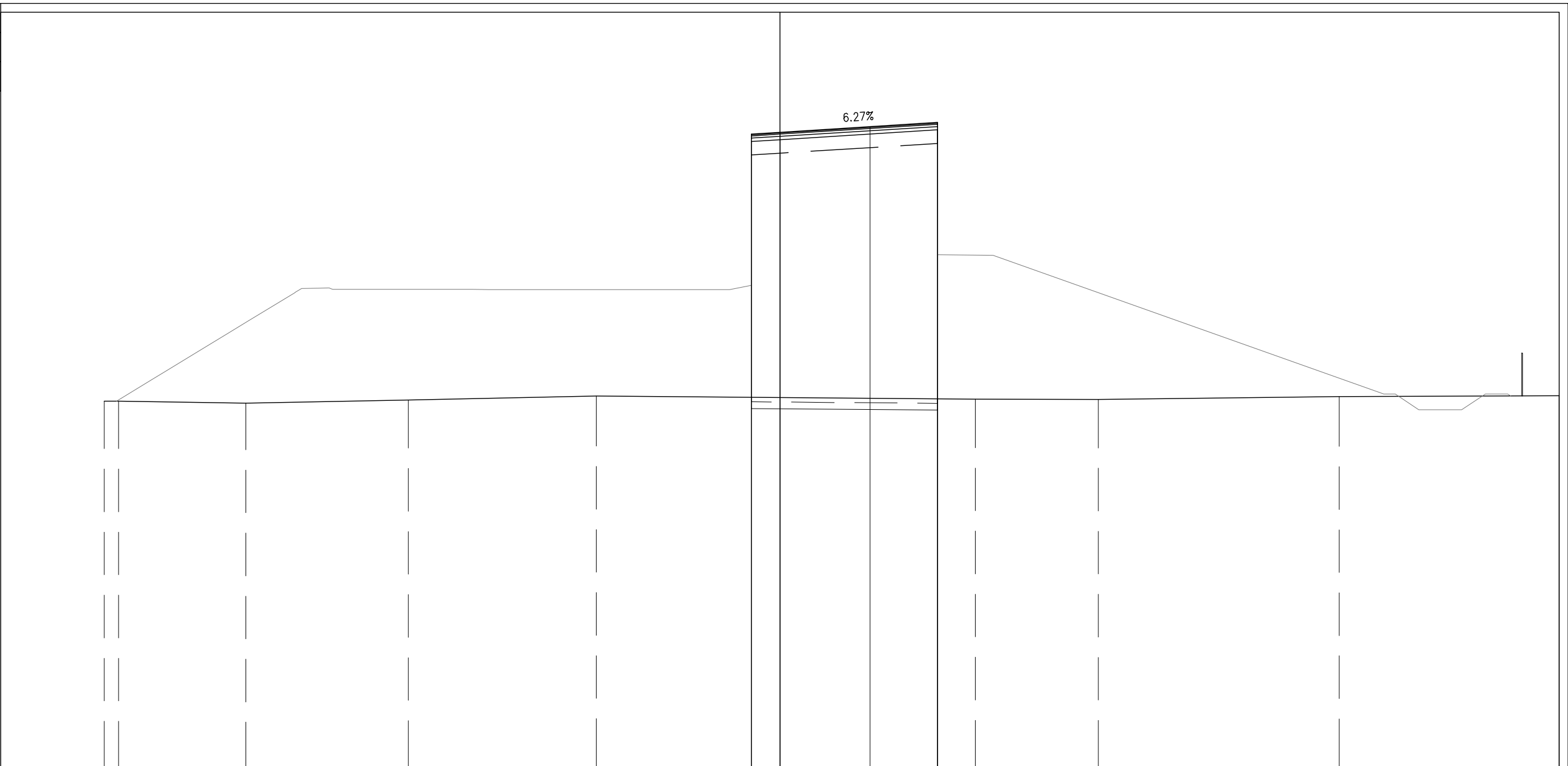

PROGRESSIVE TERRENO	-30.00	-29.36	-23.72	-16.50	-8.15	16.83	8.68	14.14	24.83	34.60
PARZIALI TERRENO	0.64	5.64	7.22	8.35	16.83	5.46	10.69	9.77		
QUOTE TERRENO	12.32	12.33	12.24	12.38	12.55	12.42	12.40	12.54	12.56	
PROGRESSIVE PROGETTO						-1.27	0.00	4.00	7.00	
PARZIALI PROGETTO						1.27	4.00	3.00		
QUOTE PROGETTO						24.19	24.27	24.52	24.70	
PROGRESSIVE RILEVATO						-1.27	0.00	7.00	7.00	
PARZIALI RILEVATO						1.27	7.00			
QUOTE RILEVATO	23.86	12.50	23.94			12.43	24.37			

PROFILO SV-FINALE-CR
 SEZIONE CR-23
 PROGRESSIVA 350.00

BASE	
C1	0.91 mq.
CEMENTATO	
CE1	1.42 mq.
VEGETALE	
D1	2.80 mq.
D2	6.86 mq.
Totale:	9.66 mq.
SOTTOFONDAZIONE STRADALE	
H1	7.09 mq.
RILEVATO ARGINELLO	
RA1	0.12 mq.
RA2	0.18 mq.
Totale:	0.30 mq.
RILEVATO	
RI1	287.47 mq.
RIEMPIMENTO	
RP1	2.71 mq.
SCAVO FOSSI	
SF1	2.06 mq.
RILEVATO FOSSI	
VF1	1.63 mq.
TAPPETO DRENANTE	
a1	8.40 ml.
BINDER	
b1	8.94 ml.
BONIFICA	
bo1	39.28 ml.
INERBIMENTO	
i3	12.38 ml.
i4	23.24 ml.
Totale:	35.62 ml.
SCOTICO	
sc2	39.28 ml.
SCOTICO FOSSI	
sf1	5.50 ml.

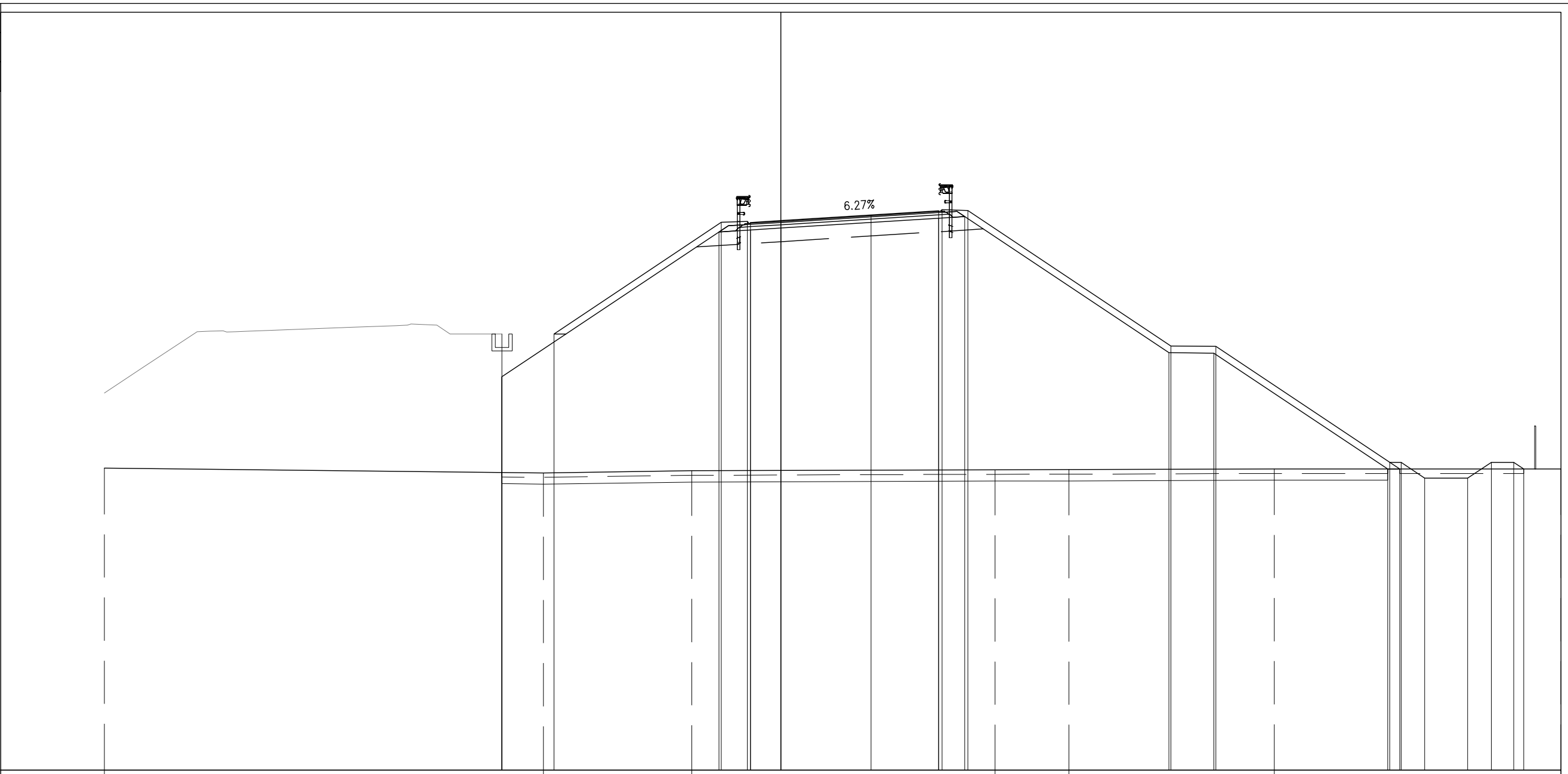

PROGRESSIVE TERRENO	-30.00	-10.53	-3.95		9.50	12.78		21.88		34.60										
PARZIALI TERRENO	19.47	6.58	13.45	3.28	9.10	12.72														
QUOTE TERRENO	12.40	12.18	12.28		12.32	12.33		12.35		12.36										
PROGRESSIVE PROGETTO		-12.37	-10.06	-2.64	4.00	7.00	7.15	8.30	17.30	19.30	27.01	27.51	28.56	30.46	31.51	32.51	32.95			
PARZIALI PROGETTO		2.31	7.42	1.15	4.00	3.00	0.15	1.15	9.00	2.00	7.71	0.50	1.05	1.90	1.05	1.00	0.44			
QUOTE PROGETTO		18.34	18.34	23.29	23.33	23.28	23.36	23.61	23.80	23.86	23.81	17.81	17.79	12.65	12.65	11.95	11.95	12.65	12.65	12.36
PROGRESSIVE RILEVATO		-12.37	-12.37	-2.74	7.00	8.16		17.21	19.21	26.91	27.45									
PARZIALI RILEVATO		9.63	1.40	1.34	7.00	1.16		9.05	2.00	7.70	0.54									
QUOTE RILEVATO		12.20	16.44	22.86	22.95	23.03	23.47	23.54	17.51	17.49	12.35	12.35								

PROFILO SV-FINALE-CR

SEZIONE CR-25

PROGRESSIVA 400.00

BASE	
C1	0.93 mq.
CEMENTATO	
CE1	1.45 mq.
VEGETALE	
D1	1.51 mq.
D2	5.62 mq.
Totale:	7.13 mq.
SOTTOFONDAZIONE STRADALE	
H1	7.16 mq.
RILEVATO ARGINELLO	
RA1	0.17 mq.
RA2	0.13 mq.
Totale:	0.30 mq.
RILEVATO	
RI1	190.25 mq.
RIEMPIMENTO	
RP1	2.35 mq.
SCAVO FOSSI	
SF1	2.05 mq.
RILEVATO FOSSI	
VF1	2.50 mq.
TAPPETO DRENANTE	
a1	8.52 ml.
BINDER	
b1	9.07 ml.
BONIFICA	
bo1	32.24 ml.
INERBIMENTO	
i3	7.90 ml.
i4	18.85 ml.
Totale:	26.75 ml.
SCOTICO	
sc2	32.24 ml.
SCOTICO FOSSI	
sf1	5.49 ml.

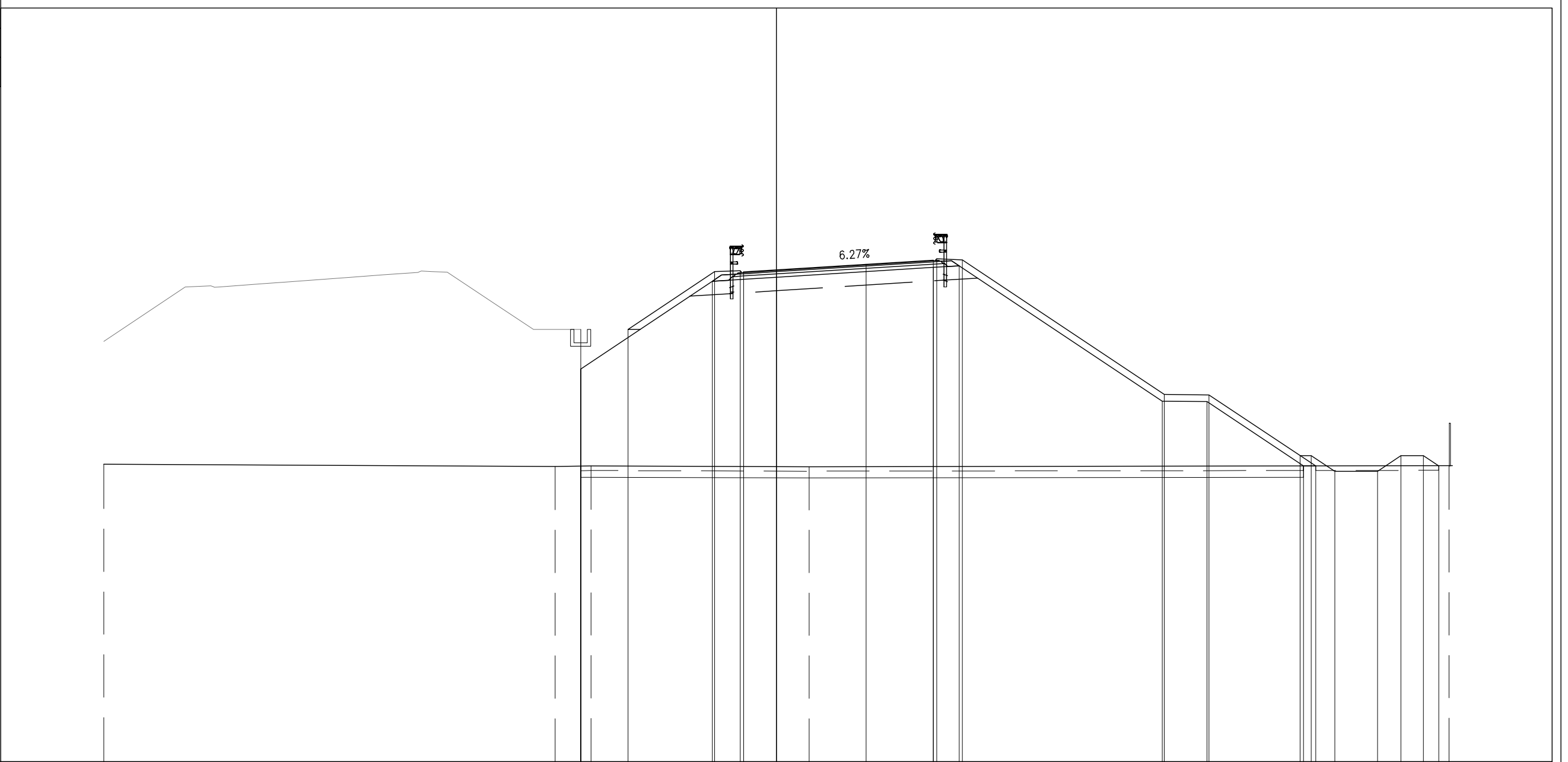

PROGRESSIVE TERRENO	-30.00			-9.87	-8.26					1.47											30.00
PARZIALI TERRENO		20.13		1.61		9.73						28.53									
QUOTE TERRENO	12.26			12.16	12.18					12.15											12.20
PROGRESSIVE PROGETTO				-8.73	-6.62			-2.76	-1.61	-1.46	0.00		4.00		7.00	7.15				17.30	19.30
PARZIALI PROGETTO				2.11	3.86		1.15	0.15	1.46	4.00		3.00	0.15	1.15	9.00	2.00	4.06	0.50	23.36	23.86	24.91
QUOTE PROGETTO				18.28	18.28		20.85	20.89	20.84	20.93		21.18	21.37	21.42	21.38	15.38	15.36		12.65	12.65	11.95
PROGRESSIVE RILEVATO				-8.73	-8.73		-2.86	-1.46	0.00						7.00	8.16			17.21	19.21	23.51
PARZIALI RILEVATO				5.87		1.40	1.46	7.00		1.16		9.05	2.00	4.30	0.54				23.51	24.05	
QUOTE RILEVATO				12.18	16.51		20.42	20.51	20.60						21.04	21.11			15.08	15.06	12.19

PROFILO SV-FINALE-CR
 SEZIONE CR-26
 PROGRESSIVA 425.00

BASE
 C1 0.91 mq.
 CEMENTATO
 CE1 1.46 mq.
 VEGETALE
 D1 0.84 mq.
 D2 4.92 mq.
 Totale: 5.76 mq.
 SOTTOFONDAZIONE STRADALE
 H1 7.15 mq.
 RILEVATO ARGINELLO
 RA1 0.13 mq.
 RA2 0.15 mq.
 Totale: 0.28 mq.
 RILEVATO
 RI1 138.14 mq.
 RIEMPIMENTO
 RP1 1.69 mq.
 SCAVO FOSSI
 SF1 2.05 mq.
 RILEVATO FOSSI
 VF1 2.00 mq.
 TAPPETO DRENANTE
 a1 8.51 ml.
 BINDER
 b1 9.05 ml.
 BONIFICA
 bo1 27.96 ml.
 INERBIMENTO
 i2 5.29 ml.
 i3 16.59 ml.
 Totale: 21.88 ml.
 SCOTICO
 sc2 27.96 ml.
 SCOTICO FOSSI
 sf1 5.51 ml.

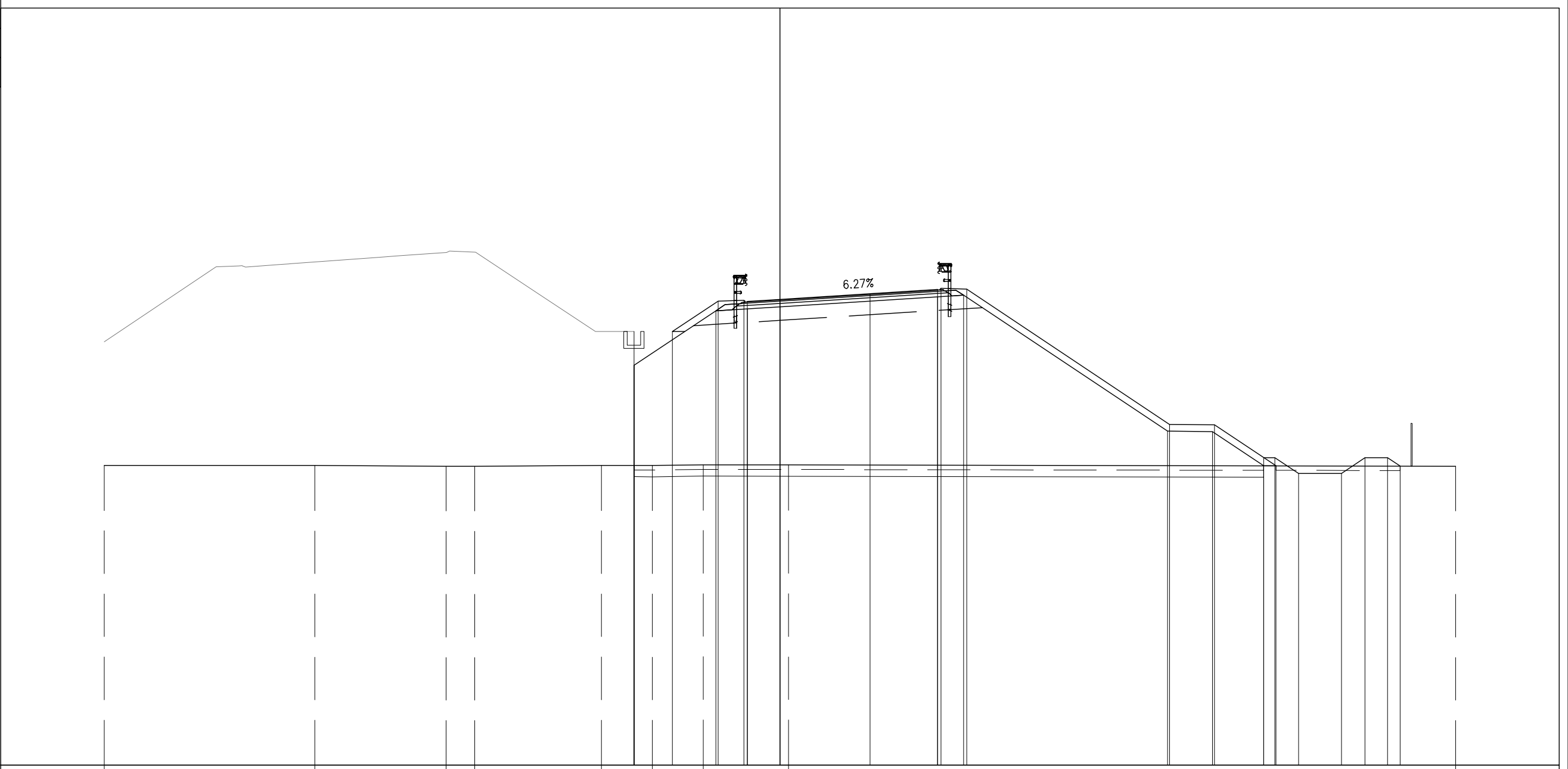

PROGRESSIVE TERRENO	-30.00	-20.66	-14.82	-13.55	-7.92	-5.66	-3.41	0.38		30.00																
PARZIALI TERRENO	9.34	5.84	1.27	5.63	2.26	2.25	3.79	29.62																		
QUOTE TERRENO	12.31	12.30	12.27	12.27	12.31	12.30	12.33	12.33		12.27																
PROGRESSIVE PROGETTO					-6.48	-4.77	-2.75	-1.60	-1.45	0.00	4.00	4.00	7.00	7.15	8.30		17.30	19.30	21.48	21.98	23.03	24.93	25.98	26.98	27.54	
PARZIALI PROGETTO					1.71	2.02	1.15	0.15	1.45	4.00	3.00	0.15	1.15	9.00	2.00	2.18	0.50	1.05	1.90	1.05	1.05	1.00	1.00	0.56	0.56	
QUOTE PROGETTO					18.24	18.24	19.59	19.64	19.58	19.67	19.92	20.11	20.17	20.12	14.12	14.10	12.65	12.65	11.95	11.95	12.65	12.65	12.65	12.65	12.28	12.28
PROGRESSIVE RILEVATO					-6.48	-6.48	-2.85	-1.45	0.00			7.00	8.16		17.21	19.21	21.48	22.03								
PARZIALI RILEVATO					3.63	1.40	1.45	7.00	1.16	9.05	2.00	2.27	0.55													
QUOTE RILEVATO					16.74	12.30	19.16	19.25	19.34			19.78	19.85		13.82	13.80	12.29	12.29								

-1
 200
 200

PROFILO SV-FINALE-CR
 SEZIONE CR-27
 PROGRESSIVA 441.47

BASE	
C1	0.89 mq.
CEMENTATO	
CE1	1.39 mq.
VEGETALE	
D1	0.45 mq.
D2	4.63 mq.
Totale:	5.08 mq.
SOTTOFONDAZIONE STRADALE	
H1	6.94 mq.
RILEVATO ARGINELLO	
RA1	0.13 mq.
RA2	0.16 mq.
Totale:	0.29 mq.
RILEVATO	
RI2	121.89 mq.
RIEMPIMENTO	
RP1	1.41 mq.
SCAVO FOSSI	
SF1	2.05 mq.
RILEVATO FOSSI	
VF1	4.01 mq.
TAPPETO DRENANTE	
a1	8.16 ml.
BINDER	
b1	8.70 ml.
BONIFICA	
bo1	25.76 ml.
INERBIMENTO	
i3	3.82 ml.
i4	15.22 ml.
Totale:	19.04 ml.
SCOTICO	
sc2	25.76 ml.
SCOTICO FOSSI	
sf1	5.50 ml.

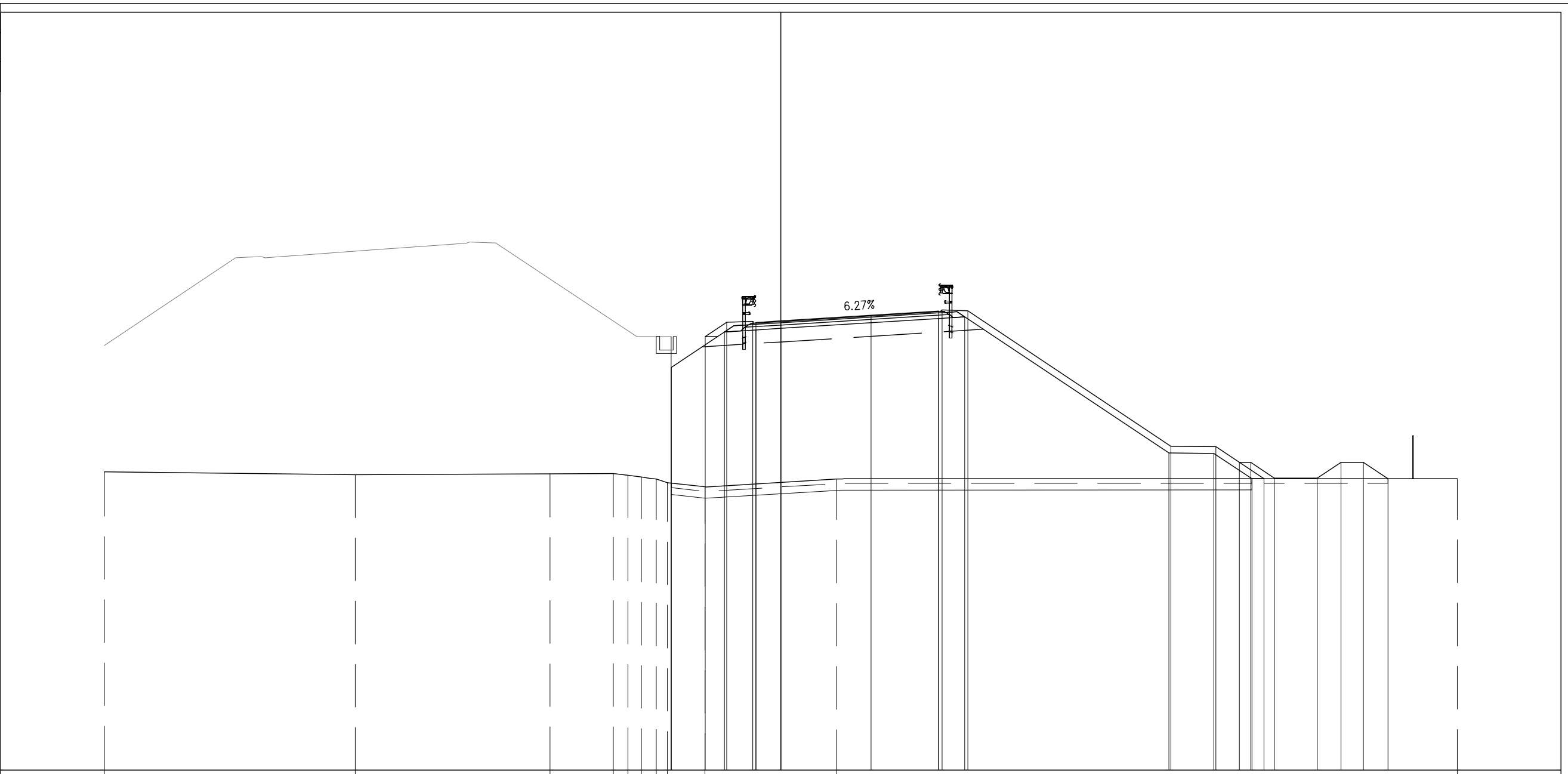

PROGRESSIVE TERRENO	-30.00	-18.87	-10.23	-7.43	-6.78	-6.18	-5.53	-5.03	-3.37	2.47	30.00											
PARZIALI TERRENO		11.13	8.64	2.80	0.65	0.60	0.65	0.50	1.66	5.84	27.53											
QUOTE TERRENO	12.22	12.09	12.14	12.15	12.08	11.99	11.91	11.74	11.56	11.90	11.92											
PROGRESSIVE PROGETTO				-4.87	-3.35	-2.40	-1.25	-1.10	0.00	4.00	7.00	7.15	8.30	17.30	19.30	20.34	20.84	21.89	23.79	24.84	25.84	26.93
PARZIALI PROGETTO				1.52	0.95	1.15	0.15	1.10	4.00	3.00	0.15	1.15	9.00	2.00	1.05	0.50	1.05	1.90	1.05	1.00	1.09	
QUOTE PROGETTO				18.22	18.22	18.86	18.90	18.85	18.91	19.17	19.35	19.41	19.36	13.36	13.34	12.65	12.65	11.95	11.95	12.65	12.65	11.92
PROGRESSIVE RILEVATO				-4.87	-4.87	-2.50	-1.10	0.00	7.00	8.16	17.21	19.21	20.89	21.43	23.79	24.84	25.84	26.93				
PARZIALI RILEVATO				2.37	1.40	1.10	7.00	1.16	9.05	2.00	1.68	0.54										
QUOTE RILEVATO				16.85	11.73	18.43	18.52	18.58	19.02	19.10	13.06	13.04	11.92	11.92								

PROFILO SV-FINALE-CR

SEZIONE CR-30

PROGRESSIVA 478.46

BASE	
C1	0.88 mq.
CEMENTATO	
CE1	1.37 mq.
VEGETALE	
D1	0.24 mq.
D2	3.11 mq.
Totale:	3.35 mq.
SOTTOFONDAZIONE STRADALE	
H1	6.64 mq.
RILEVATO ARGINELLO	
RA1	0.14 mq.
RA2	0.15 mq.
Totale:	0.29 mq.
RILEVATO	
RI1	68.31 mq.
SCAVO FOSSI	
SF1	2.06 mq.
RILEVATO FOSSI	
VF1	2.99 mq.
TAPPETO DRENANTE	
a1	8.06 ml.
BINDER	
b1	8.60 ml.
BONIFICA	
bo1	18.53 ml.
INERBIMENTO	
i3	1.29 ml.
i4	10.07 ml.
Totale:	11.36 ml.
SCOTICO	
sc2	18.53 ml.
SCOTICO FOSSI	
sf1	5.30 ml.

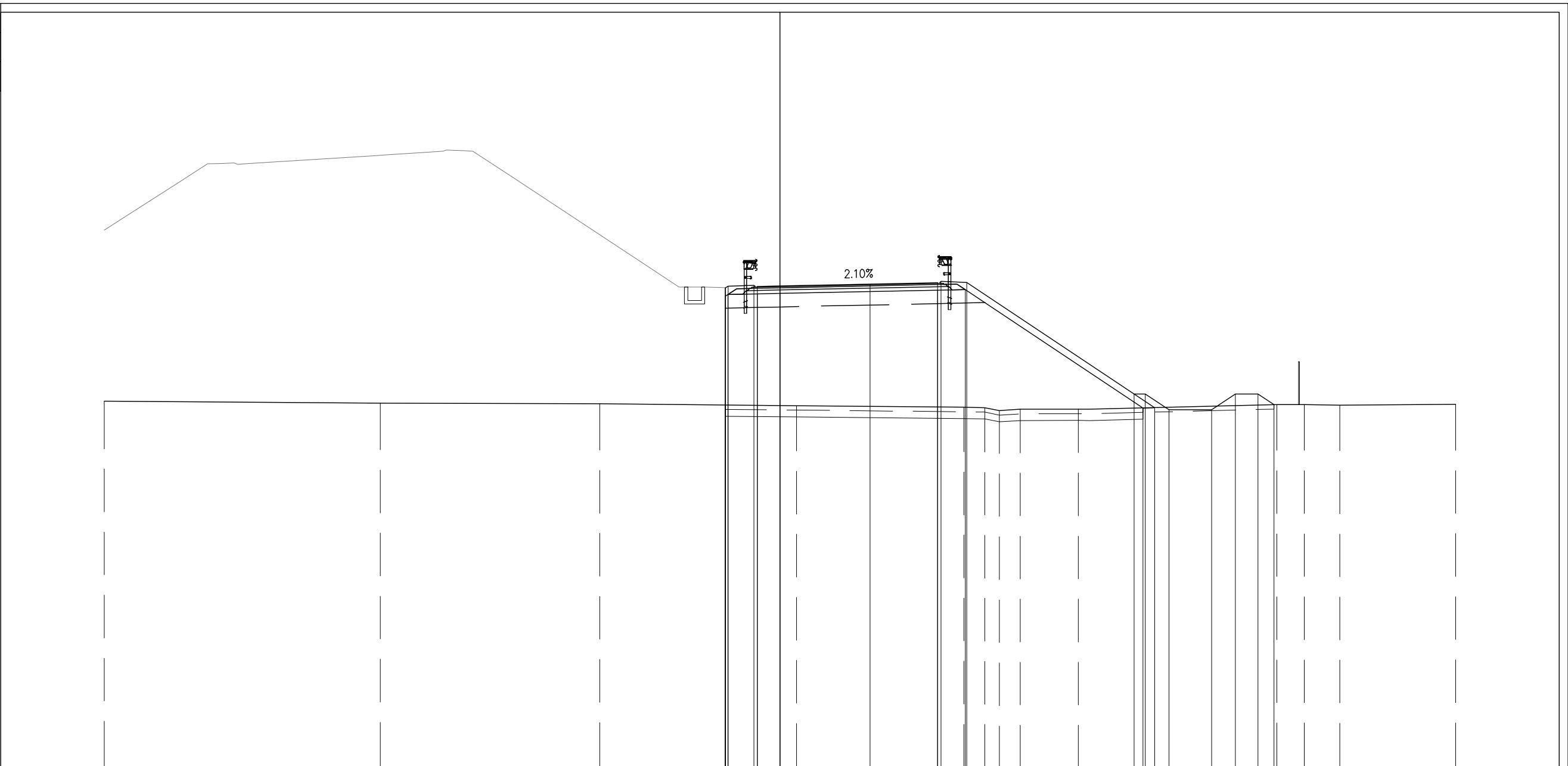

PROGRESSIVE TERRENO	-30.00	-17.74	-8.01	0.74	8.17	9.10	9.74	10.67	13.25	22.06	23.29	24.86	30.00
PARZIALI TERRENO	12.26	9.73	8.75	7.43	0.93	0.64	0.93	2.58	8.81	1.23	1.57	5.14	
QUOTE TERRENO	12.32	12.23	12.21	12.13	12.06	12.04	11.91	11.97	11.97	12.18	12.18	12.15	12.19
PROGRESSIVE PROGETTO					-2.42	-2.30	-1.15	-1.00	0.00	4.00	3.00	7.00	7.15
PARZIALI PROGETTO					0.12	1.15	0.15	1.15	7.42	0.50	1.05	1.90	1.05
QUOTE PROGETTO					17.35	17.43	17.48	17.42	17.44	17.53	17.59	17.64	17.60
PROGRESSIVE RILEVATO					-2.42	-2.42	-2.31	-1.00	0.00	7.00	8.23	16.11	16.64
PARZIALI RILEVATO					0.11	1.31	1.00	7.00	1.23	7.88	0.53	16.11	16.64
QUOTE RILEVATO					16.99	12.16	17.06	17.09	17.11	17.26	17.28	12.03	12.04

PROFILO SV-FINALE-CR

SEZIONE CR-31

PROGRESSIVA 500.00

BASE	
C1	0.88 mq.
CEMENTATO	
CE1	1.39 mq.
VEGETALE	
D1	2.50 mq.
D2	2.47 mq.
Totale:	4.97 mq.
SOTTOFONDAZIONE STRADALE	
H1	6.86 mq.
RILEVATO ARGINELLO	
RA1	0.14 mq.
RA2	0.14 mq.
Totale:	0.28 mq.
RILEVATO	
RI1	61.98 mq.
SCAVO FOSSI	
SF1	2.06 mq.
SF2	2.07 mq.
Totale:	4.13 mq.
RILEVATO FOSSI	
VF1	1.92 mq.
VF2	2.57 mq.
Totale:	4.49 mq.
TAPPETO DRENANTE	
a1	8.06 ml.
BINDER	
b1	8.60 ml.
BONIFICA	
bo1	22.94 ml.
INERBIMENTO	
i5	8.48 ml.
i6	8.53 ml.
Totale:	17.01 ml.
SCOTICO	
sc3	22.94 ml.
SCOTICO FOSSI	
sf1	5.52 ml.
sf2	5.55 ml.
Totale:	11.07 ml.

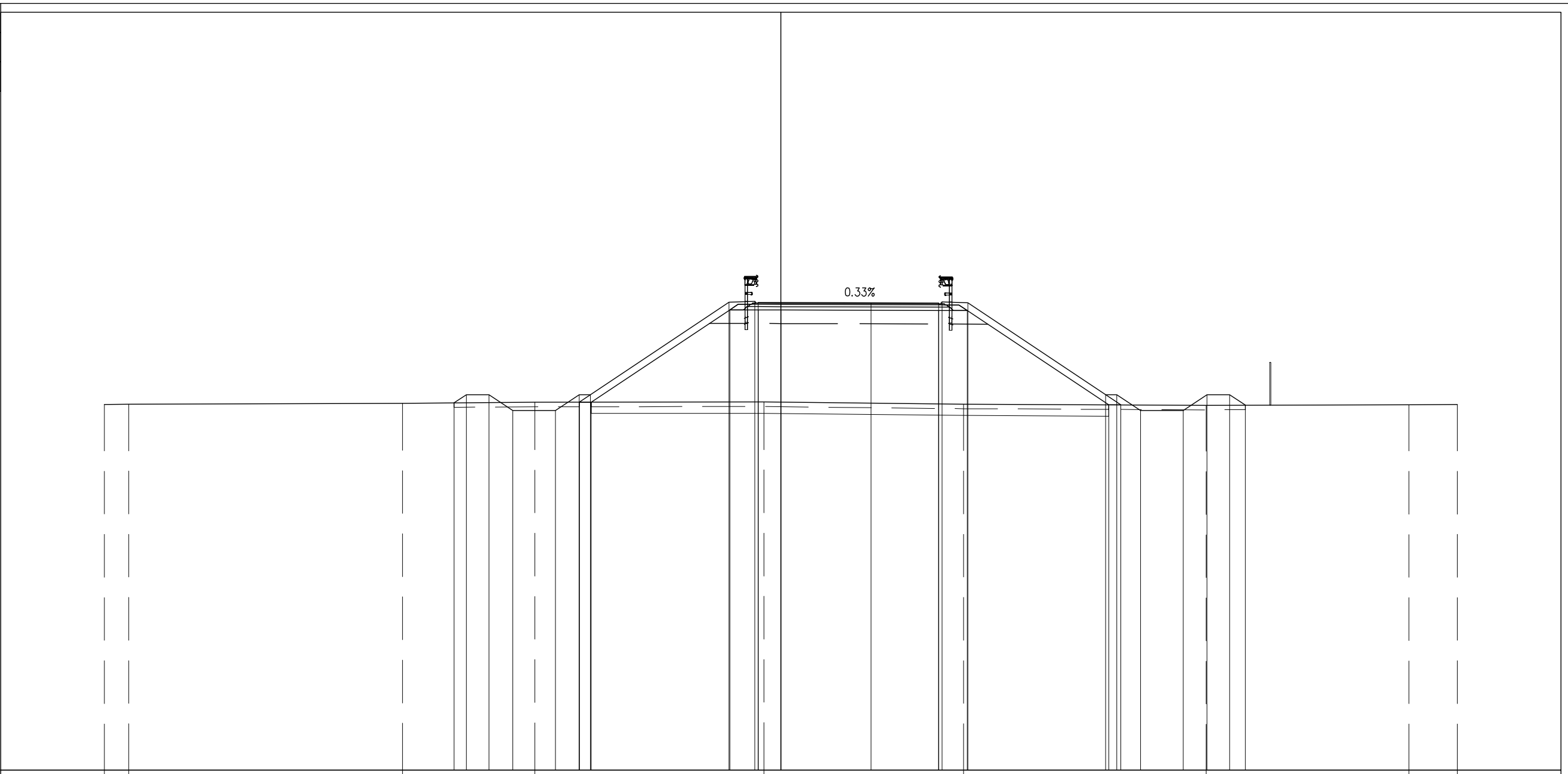

PROGRESSIVE TERRENO	-30.00	-28.92	-16.78	-10.91	-0.75	8.11	18.86	27.85	30.00
PARZIALI TERRENO	1.08	12.14	5.87	10.16	8.86	10.75	8.99	2.15	
QUOTE TERRENO	12.21	12.22	12.27	12.31	12.32	12.23	12.18	12.20	12.21
PROGRESSIVE PROGETTO			-14.49	-13.94	-12.94	-11.89	-9.99	-8.94	-8.44
PARZIALI PROGETTO			0.55	1.00	1.05	1.90	1.05	0.50	6.64
QUOTE PROGETTO			12.29	12.65	12.65	11.95	11.95	12.31	12.65
PROGRESSIVE RILEVATO			-8.94	-8.40	-2.26	-1.00	0.00	7.00	8.28
PARZIALI RILEVATO			0.54	6.14	1.26	1.00	7.00	1.28	6.26
QUOTE RILEVATO			12.31	12.31	16.41	16.40	16.40	16.38	16.37

PROFILO SV-FINALE-CR

SEZIONE CR-32

PROGRESSIVA 527.64

BASE	
C1	0.87 mq.
CEMENTATO	
CE1	1.38 mq.
VEGETALE	
D1	2.00 mq.
D2	2.14 mq.
Totale:	4.14 mq.
SOTTOFONDAZIONE STRADALE	
H1	6.87 mq.
RILEVATO ARGINELLO	
RA1	0.16 mq.
RA2	0.13 mq.
Totale:	0.29 mq.
RILEVATO	
RI1	45.11 mq.
SCAVO FOSSI	
SF1	2.06 mq.
SF2	2.05 mq.
Totale:	4.11 mq.
RILEVATO FOSSI	
VF1	2.42 mq.
VF2	2.42 mq.
Totale:	4.84 mq.
TAPPETO DRENANTE	
a1	8.06 ml.
BINDER	
b1	8.60 ml.
BONIFICA	
bo1	20.54 ml.
INERBIMENTO	
i5	6.72 ml.
i6	7.22 ml.
Totale:	13.94 ml.
SCOTICO	
sc3	20.54 ml.
SCOTICO FOSSI	
sf1	5.49 ml.
sf2	5.50 ml.
Totale:	10.99 ml.

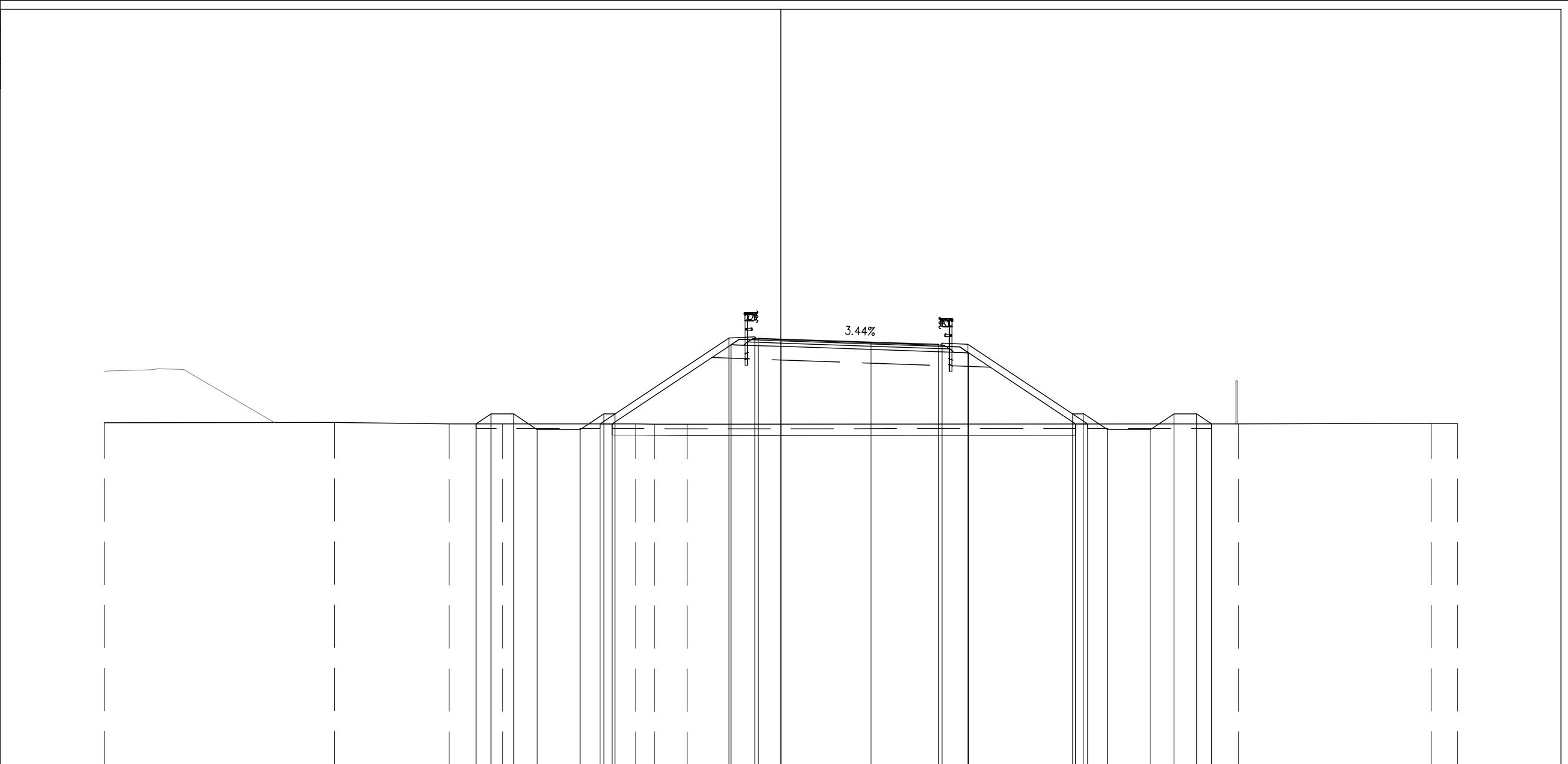

PROGRESSIVE TERRENO	-30.00	-19.81	-14.71	-12.33		-6.46	-5.62	-4.15												20.30			28.84	30.00								
PARZIALI TERRENO		10.19	5.10	2.38		5.87	0.84	1.47					24.45							8.54			1.16									
QUOTE TERRENO	12.25		12.27		12.21		12.21		12.21		12.20		12.19							12.21			12.23	12.23								
PROGRESSIVE PROGETTO				-13.52	-12.85	-11.85	-10.80	-8.90	-7.85	-7.35			-2.30	-1.15	-1.00	0.00		4.00	4.00		7.00	7.15		8.30		12.94	13.44	14.49	16.39	17.44	18.44	19.10
PARZIALI PROGETTO				0.67	1.00	1.05	1.90	1.05	0.50		5.05		1.15	0.15	1.00	4.00		3.00	0.15	1.15	4.64	0.50	1.05	1.90	1.05	1.00	0.66					
QUOTE PROGETTO				12.21	12.65	12.65	11.95	11.95	12.65	12.65			16.02	16.07	16.01	15.97		15.84		15.73	15.79		12.65	12.65	11.95	11.95	12.65	12.65	12.21			
PROGRESSIVE RILEVATO									-8.02	-7.47			-2.21	-1.00	0.00					7.00	8.34		13.07	13.61								
PARZIALI RILEVATO									0.55		5.26		1.21	1.00	7.00					1.34	4.73	0.54										
QUOTE RILEVATO									12.21	12.21			15.72	15.68	15.64					15.40	15.36		12.21	12.21								

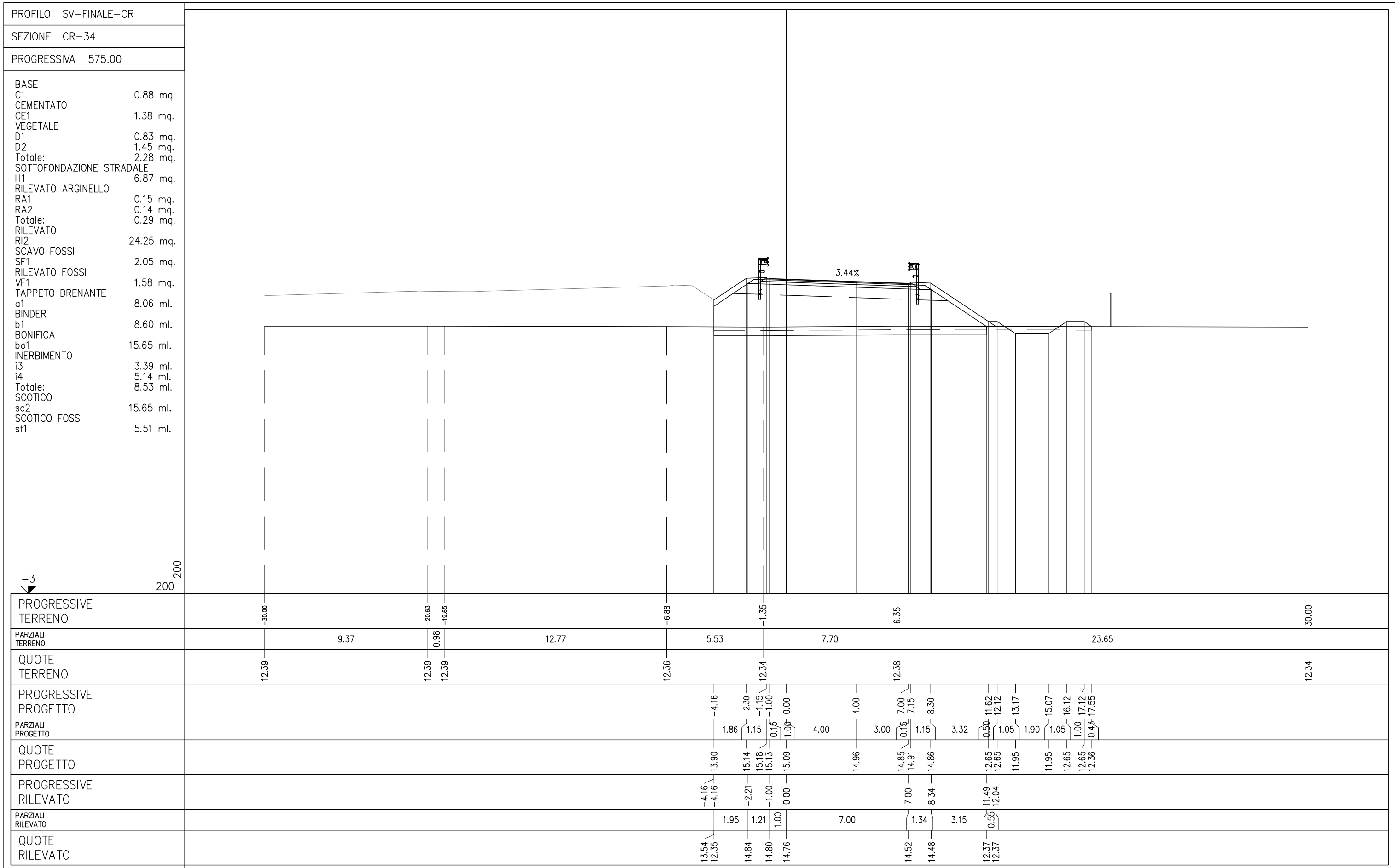

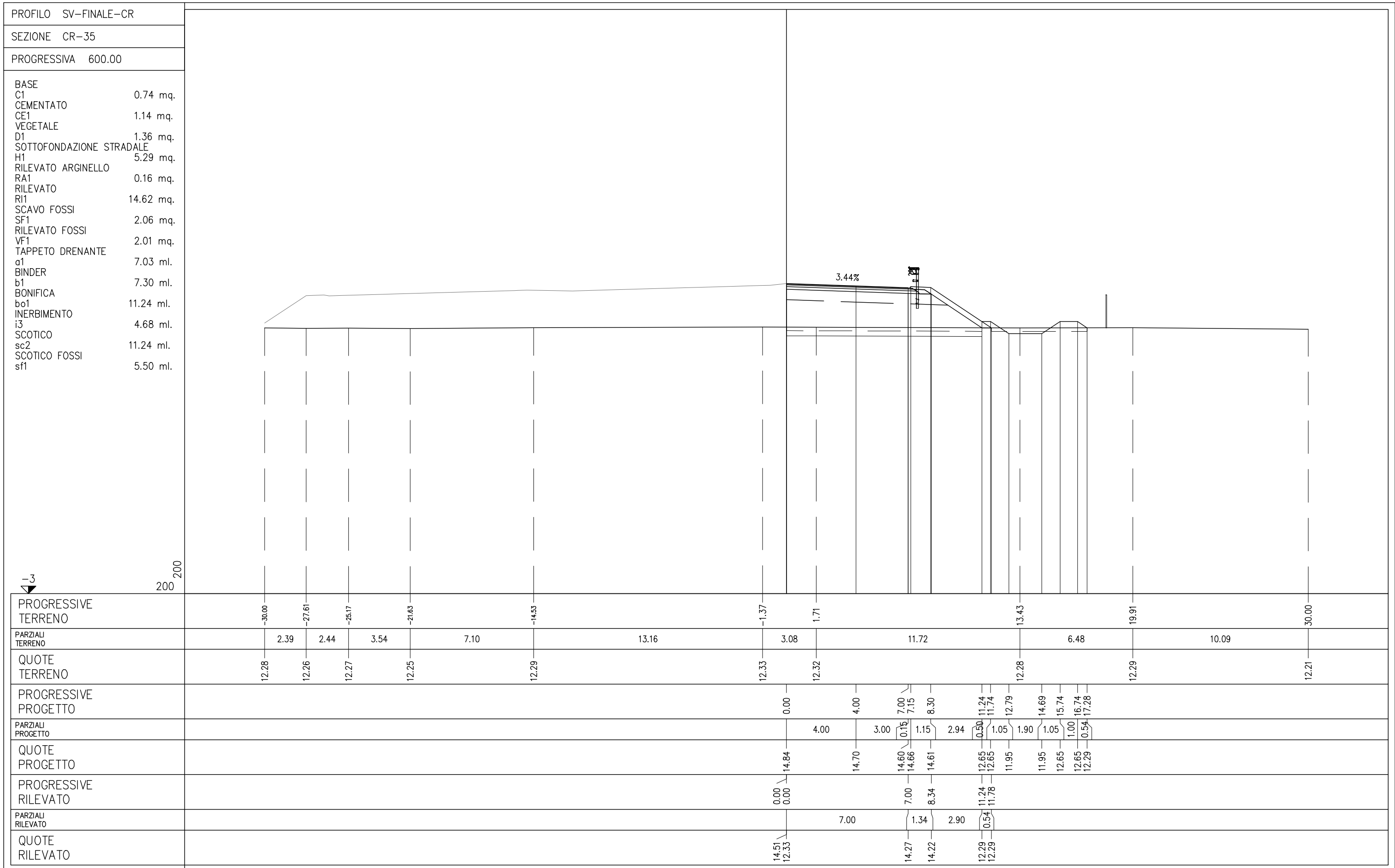

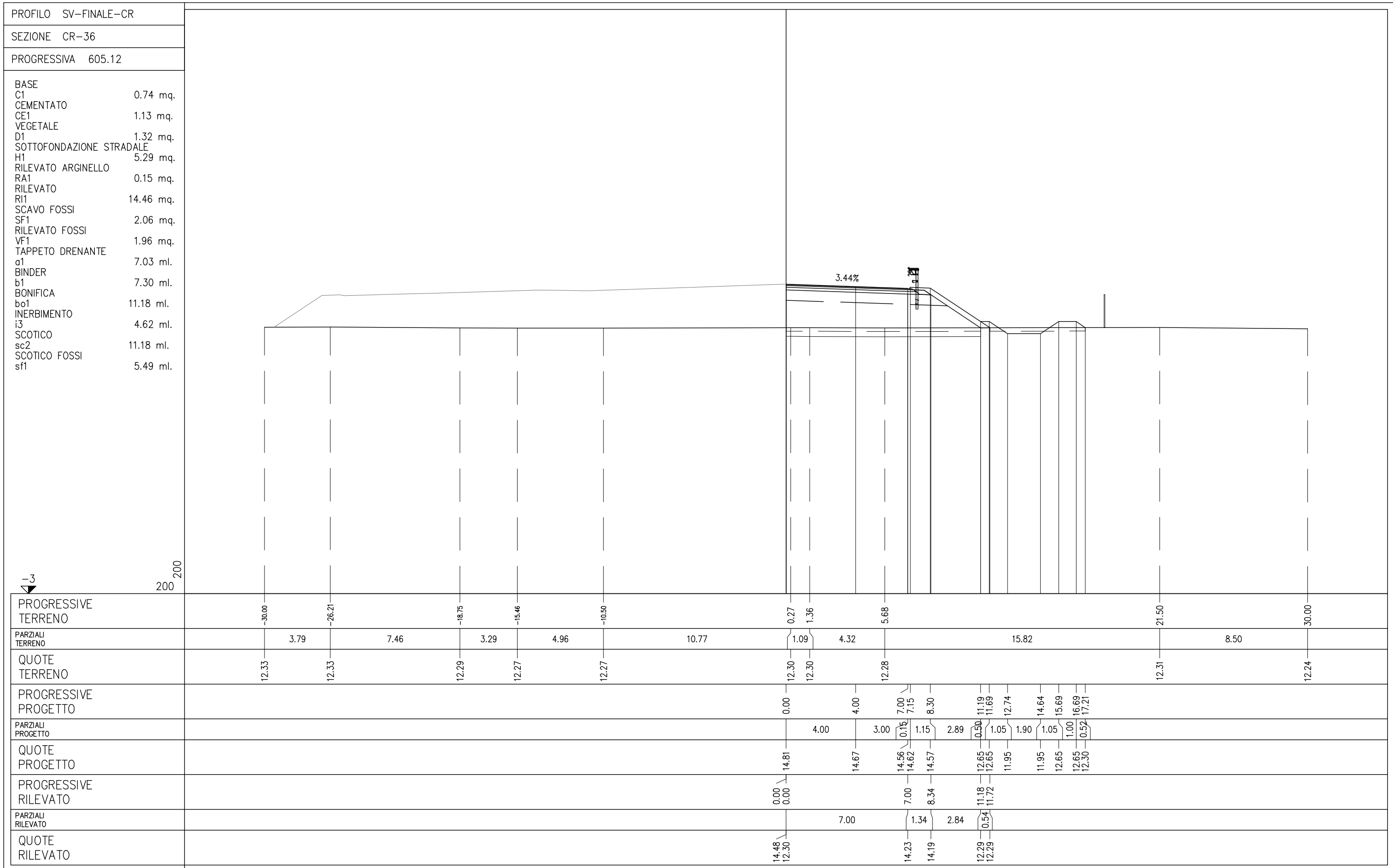

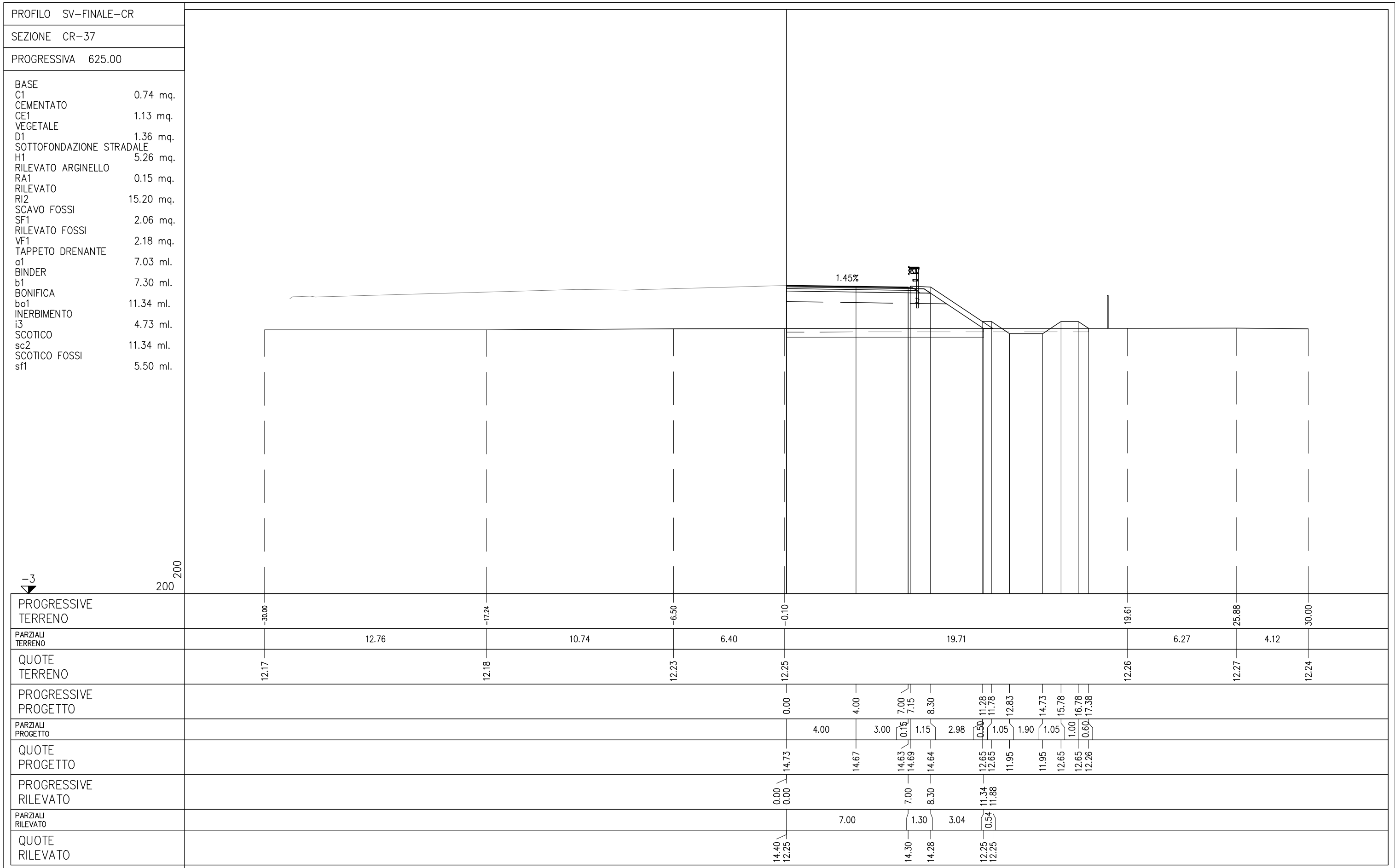

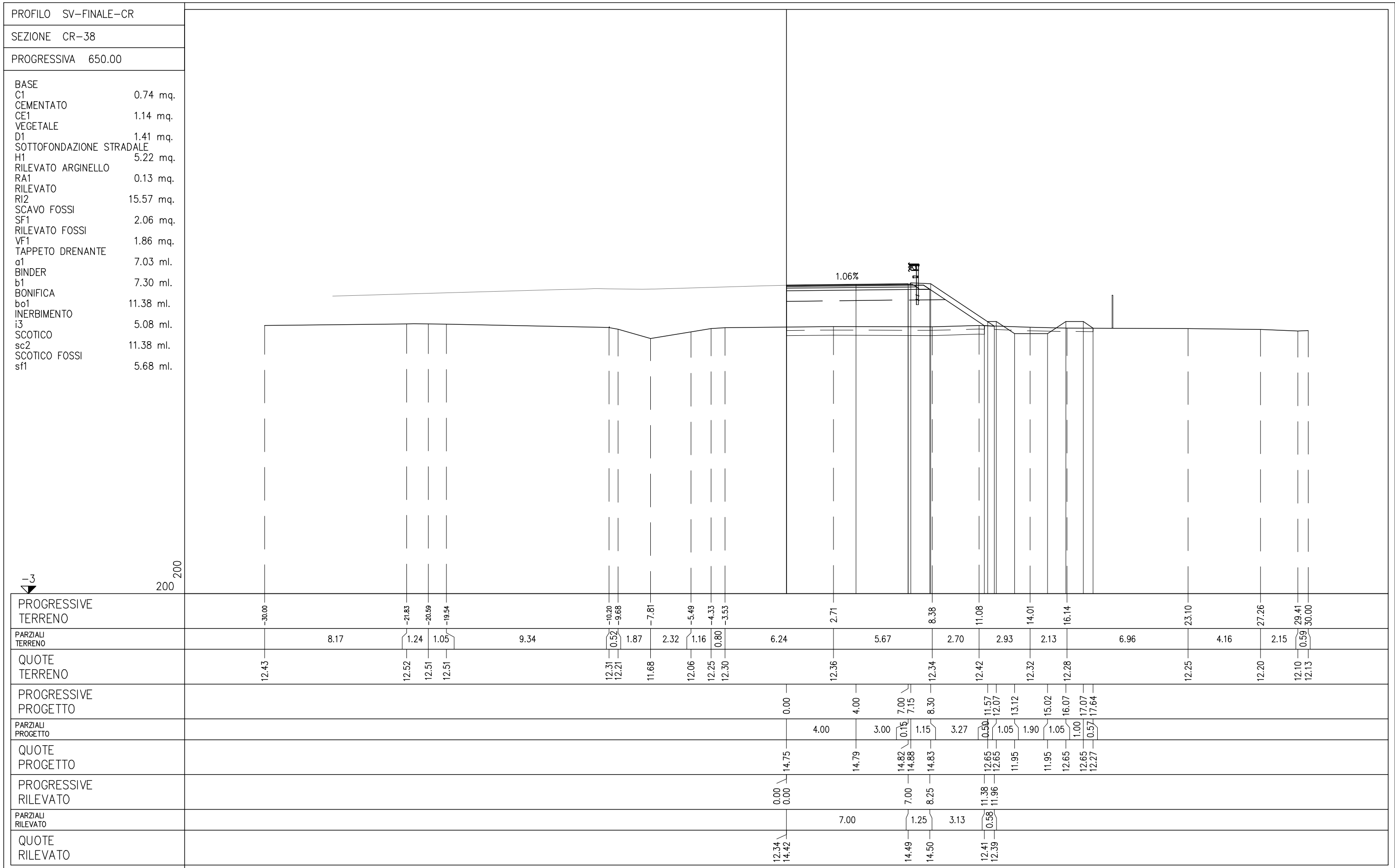

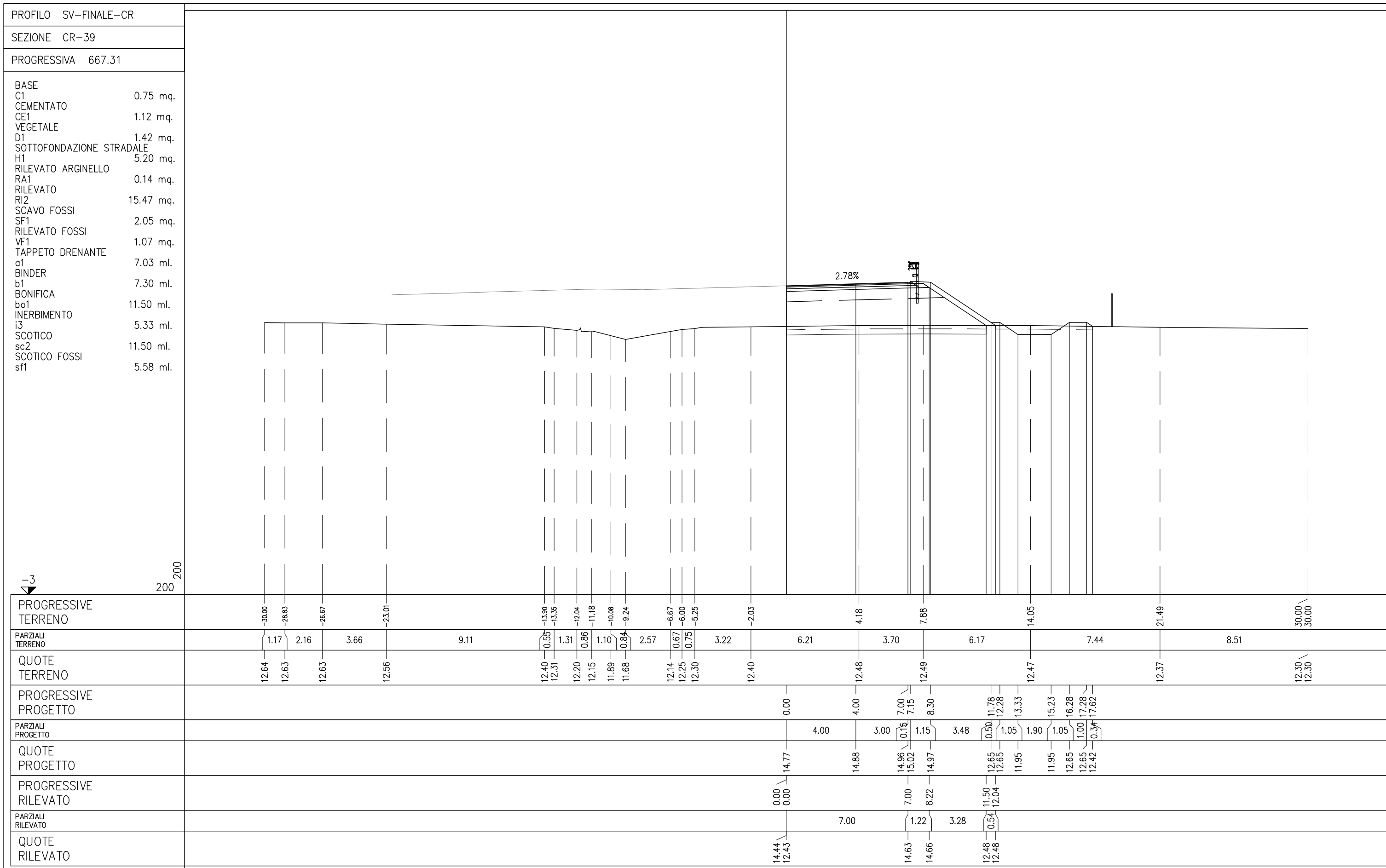

SVINCOLO DI SAN FELICE SUL PANARO - FINALE EMILIA
RAMO FC
SRA10

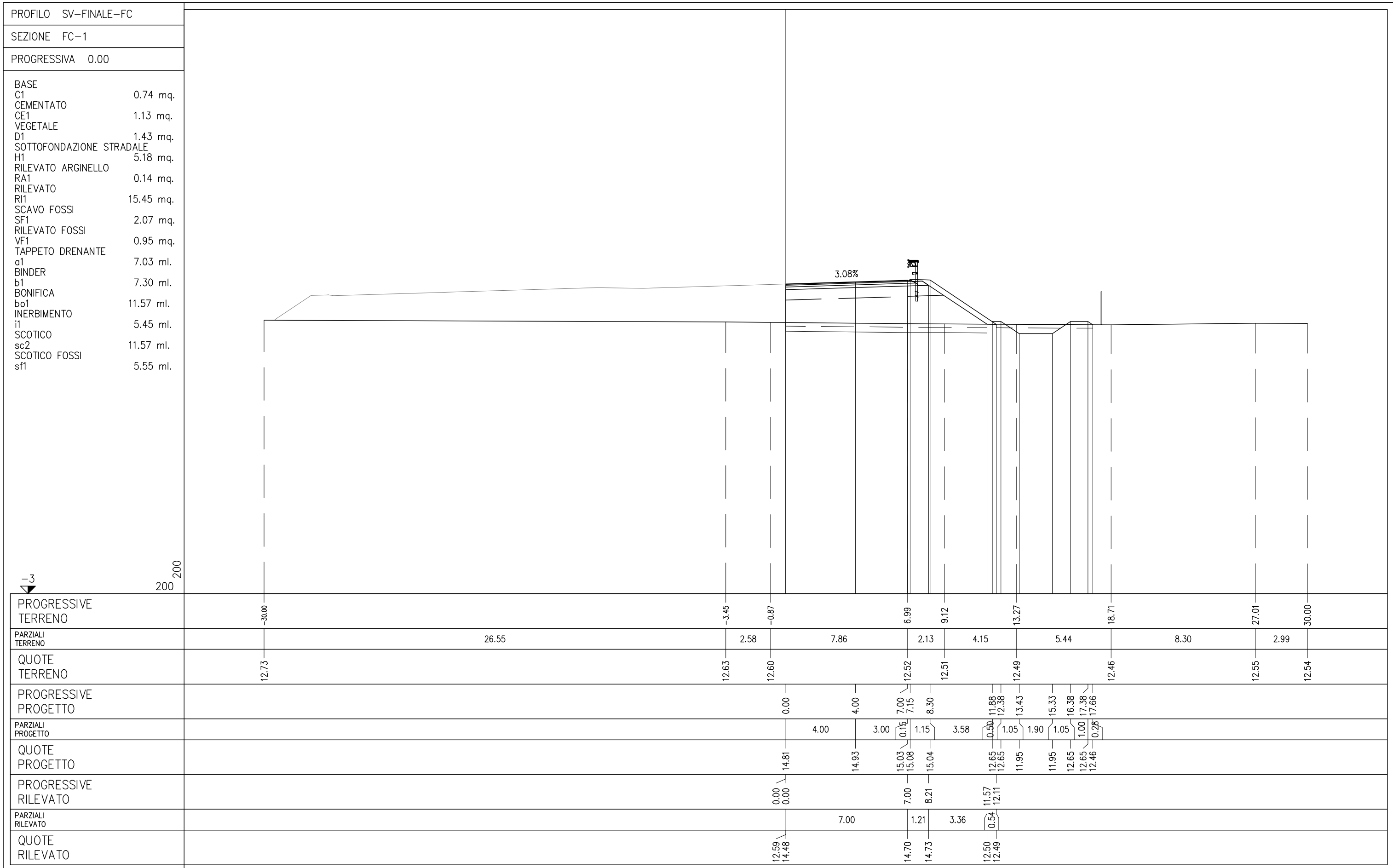

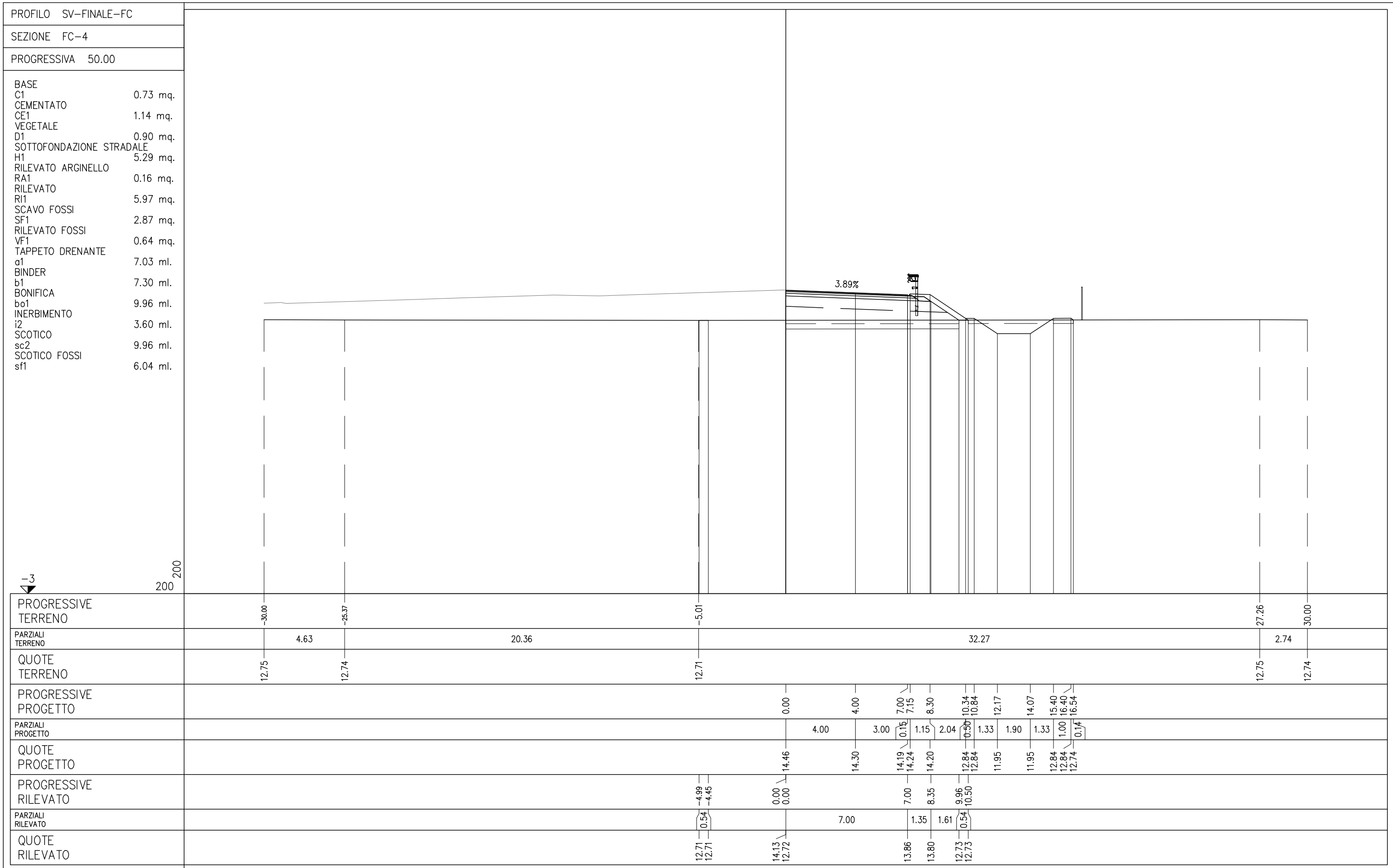

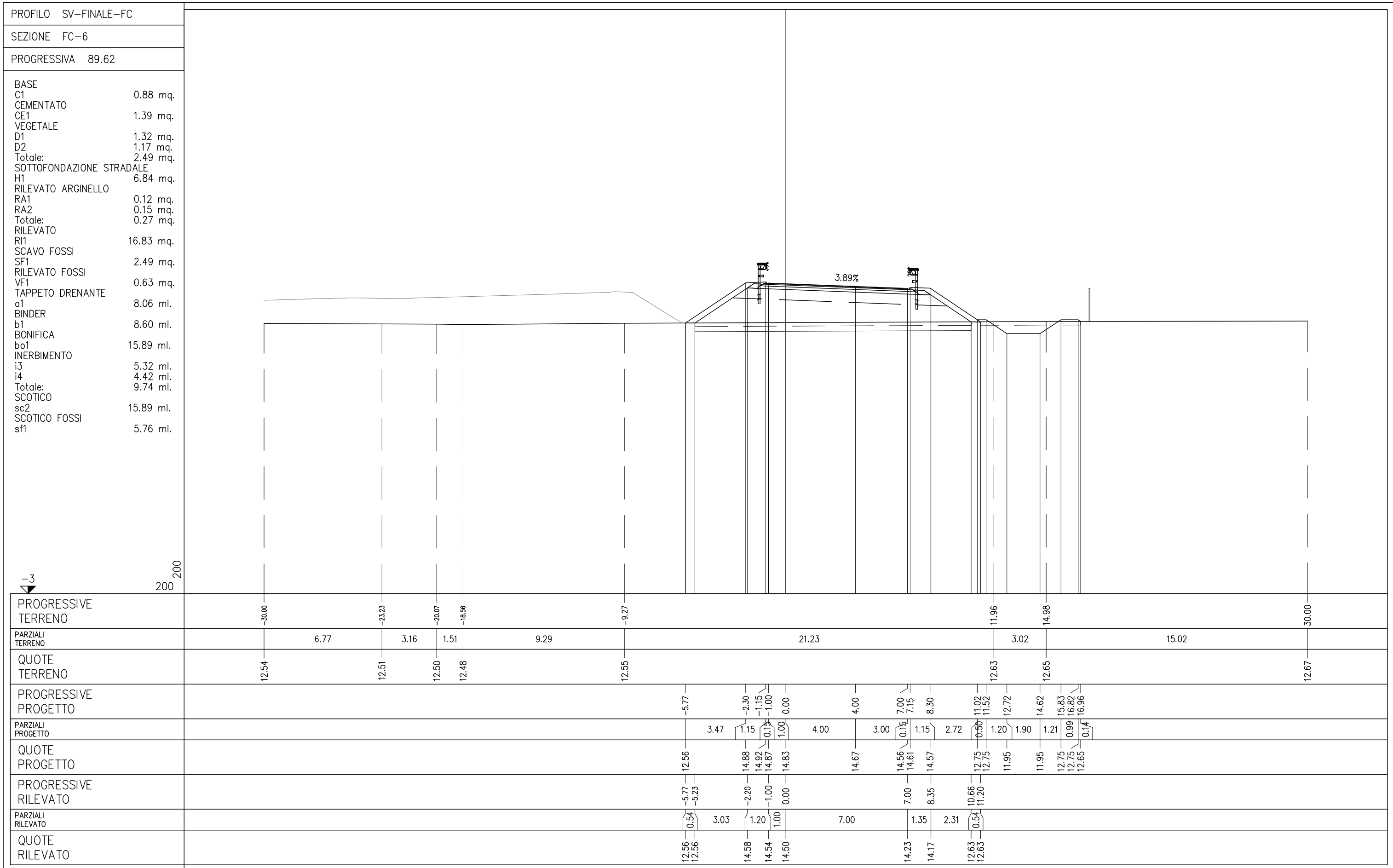

PROFILO SV-FINALE-FC
 SEZIONE FC-7
 PROGRESSIVA 100.00

BASE	
C1	0.89 mq.
CEMENTATO	
CE1	1.36 mq.
VEGETALE	
D1	1.39 mq.
D2	1.55 mq.
Totale:	2.94 mq.
SOTTOFONDAZIONE STRADALE	
H1	6.89 mq.
RILEVATO ARGINELLO	
RA1	0.13 mq.
RA2	0.16 mq.
Totale:	0.29 mq.
RILEVATO	
RI1	23.91 mq.
SCAVO FOSSI	
SF1	2.06 mq.
RILEVATO FOSSI	
VF1	0.36 mq.
TAPPETO DRENANTE	
a1	8.06 ml.
BINDER	
b1	8.60 ml.
BONIFICA	
bo1	17.19 ml.
INERBIMENTO	
i3	5.32 ml.
i4	6.06 ml.
Totale:	11.38 ml.
SCOTICO	
sc2	17.19 ml.
SCOTICO FOSSI	
sf1	5.45 ml.

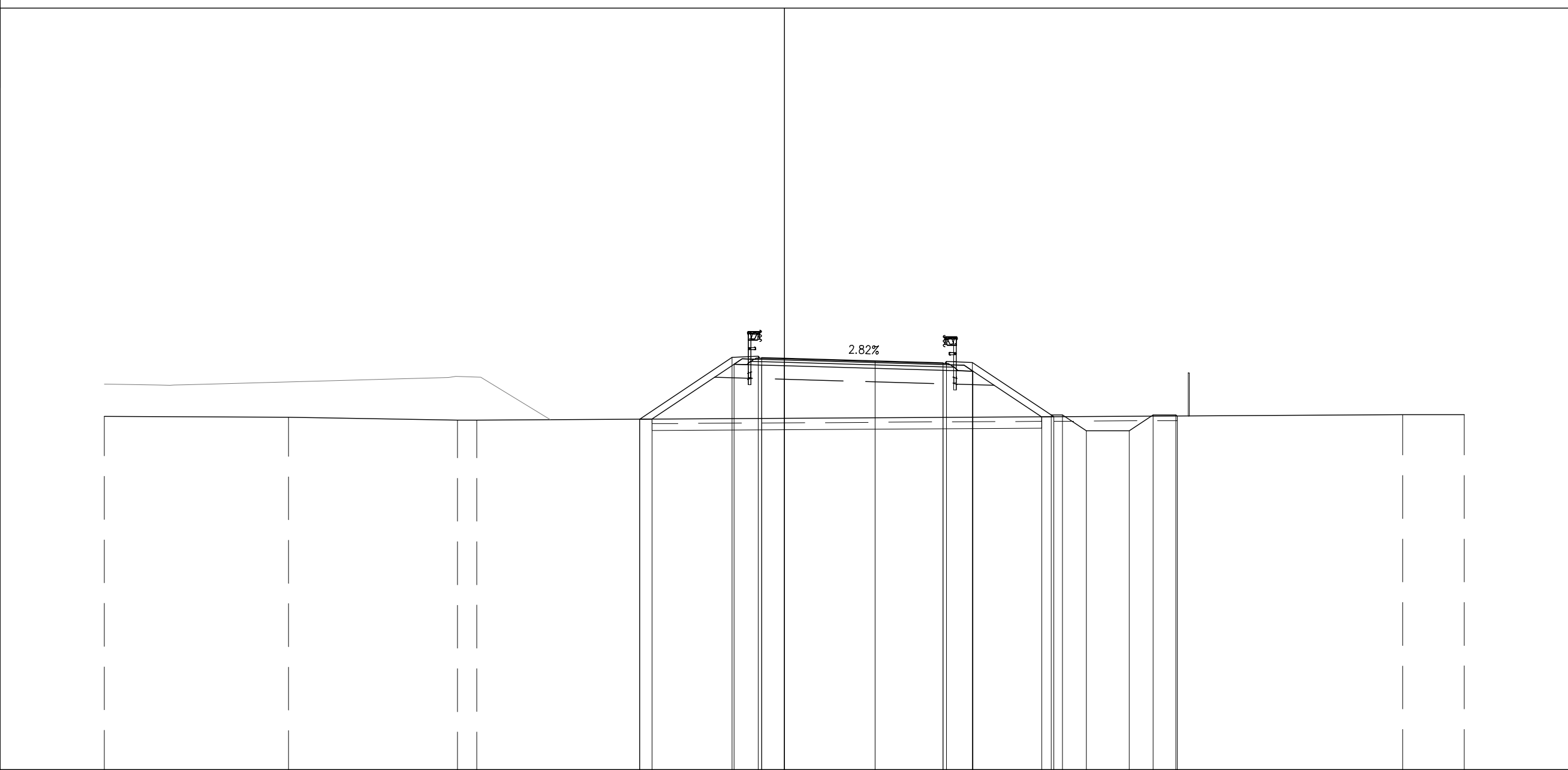

PROGRESSIVE TERRENO	-30.00	-21.88	-14.42	-13.57		27.28	30.00												
PARZIALI TERRENO	8.12	7.46	0.85	40.85			2.72												
QUOTE TERRENO	12.59	12.55	12.42	12.43	12.66			12.66											
PROGRESSIVE PROGETTO				-6.39	-2.30	-1.15	0.00	4.00	4.00	7.00	7.15	8.30	11.77	12.27	13.32	15.22	16.27	17.27	17.34
PARZIALI PROGETTO	4.09			1.15	0.15	1.00	4.00	3.00	0.15	1.15	3.47	0.50	1.05	1.90	1.05	1.00	0.07		
QUOTE PROGETTO			12.47	12.47	15.19	15.24	15.18	15.15	15.04	14.96	15.01	14.97	12.65	12.65	11.95	11.95	12.65	12.60	
PROGRESSIVE RILEVATO			-6.39	-5.84	-2.22	-1.00	0.00	7.00	8.33	11.35	11.89	13.32	15.22	16.27	17.27	17.34			
PARZIALI RILEVATO	0.55		3.62	1.22	1.00	7.00	1.33	3.02	0.54										
QUOTE RILEVATO	12.47	12.47	14.89	14.85	14.82	14.63	14.59	12.57	12.57										

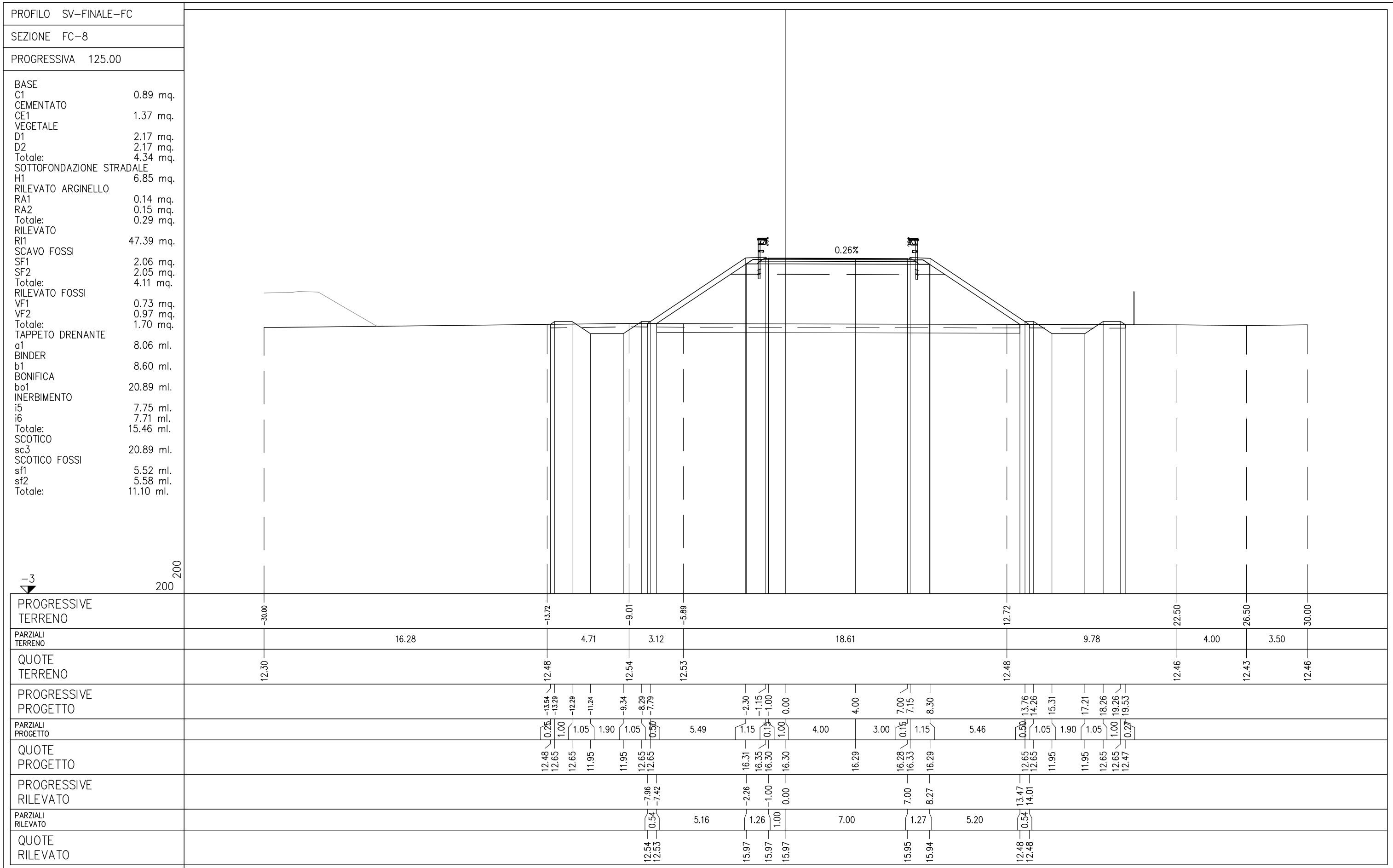

PROFILO SV-FINALE-FC

SEZIONE FC-9

PROGRESSIVA 145.68

- BASE
- C1 0.87 mq.
- CEMENTATO
- CE1 1.39 mq.
- VEGETALE
- D1 0.17 mq.
- D2 2.83 mq.
- Totale: 3.00 mq.
- SOTTOFONDAZIONE STRADALE
- H1 6.62 mq.
- RILEVATO ARGINELLO
- RA1 0.15 mq.
- RA2 0.13 mq.
- Totale: 0.28 mq.
- RILEVATO
- RI1 59.45 mq.
- SCAVO FOSSI
- SF1 2.06 mq.
- RILEVATO FOSSI
- VF1 2.01 mq.
- TAPPETO DRENANTE
- a1 8.06 ml.
- BINDER
- b1 8.60 ml.
- BONIFICA
- bo1 17.62 ml.
- INERBIMENTO
- i3 1.15 ml.
- i4 9.57 ml.
- Totale: 10.72 ml.
- SCOTICO
- sc2 17.62 ml.
- SCOTICO FOSSI
- sf1 5.48 ml.

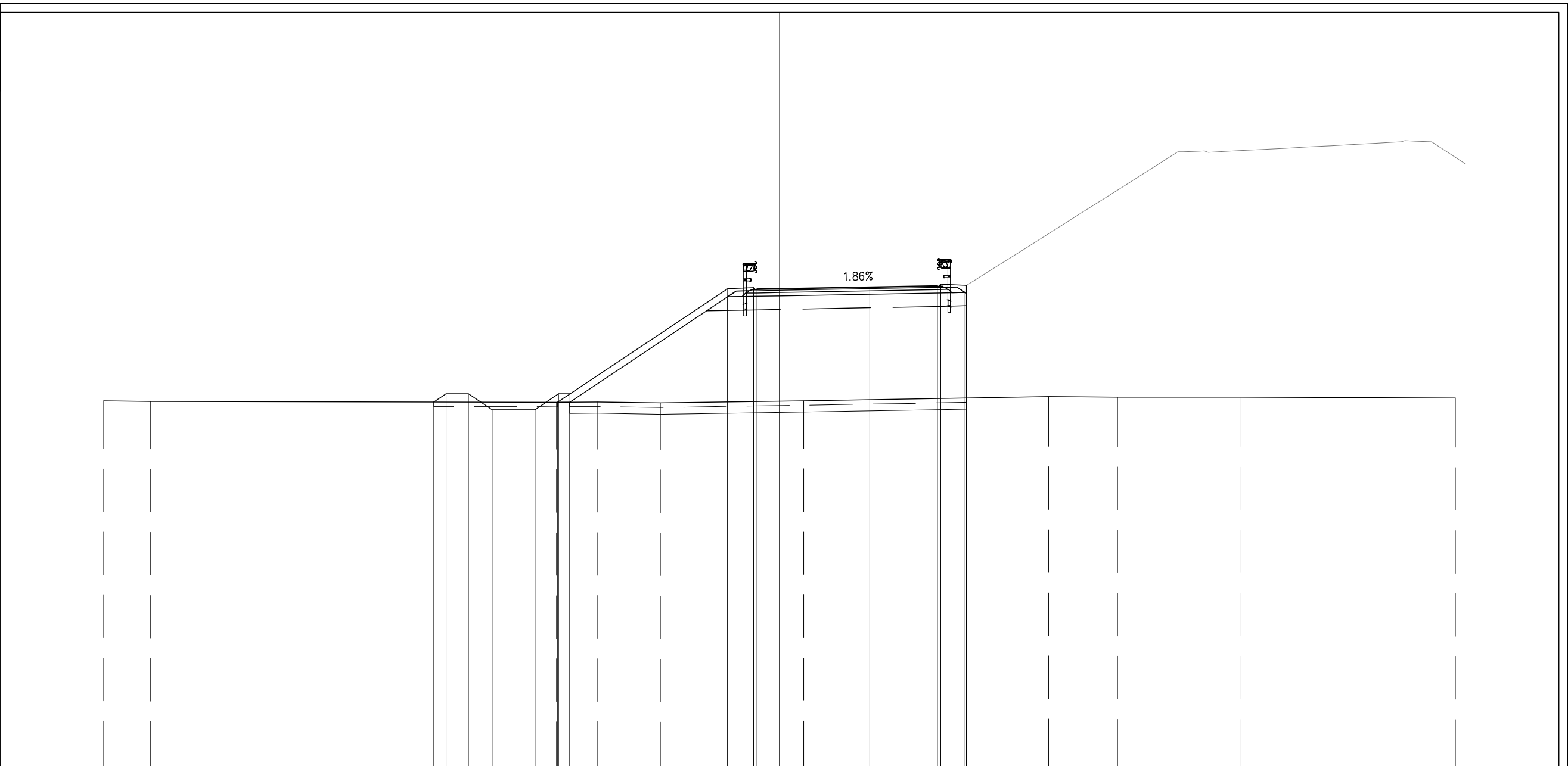

PROGRESSIVE TERRENO	-30.00	-27.93		-9.90	-8.07	-5.29		1.08		11.95	15.01	20.43	30.00
PARZIALI TERRENO	2.07		18.03	1.83	2.78		6.37		10.87	3.06	5.42		9.57
QUOTE TERRENO	12.34	12.31		12.28	12.29	12.25		12.34		12.53	12.50	12.50	12.47
PROGRESSIVE PROGETTO				-15.35	-14.81	-13.81	-12.76	-10.86	-9.81	-9.31			
PARZIALI PROGETTO				0.51	1.00	1.05	1.90	1.05	0.50		7.01		
QUOTE PROGETTO				12.29	12.65	12.65	11.95	11.95	12.65	12.65			
PROGRESSIVE RILEVATO				-9.87	-9.32			-2.31	-1.15	-1.00	0.00		
PARZIALI RILEVATO				0.55		7.01		1.31	1.00		7.00		
QUOTE RILEVATO				12.28	12.28			16.96	16.98	17.00			

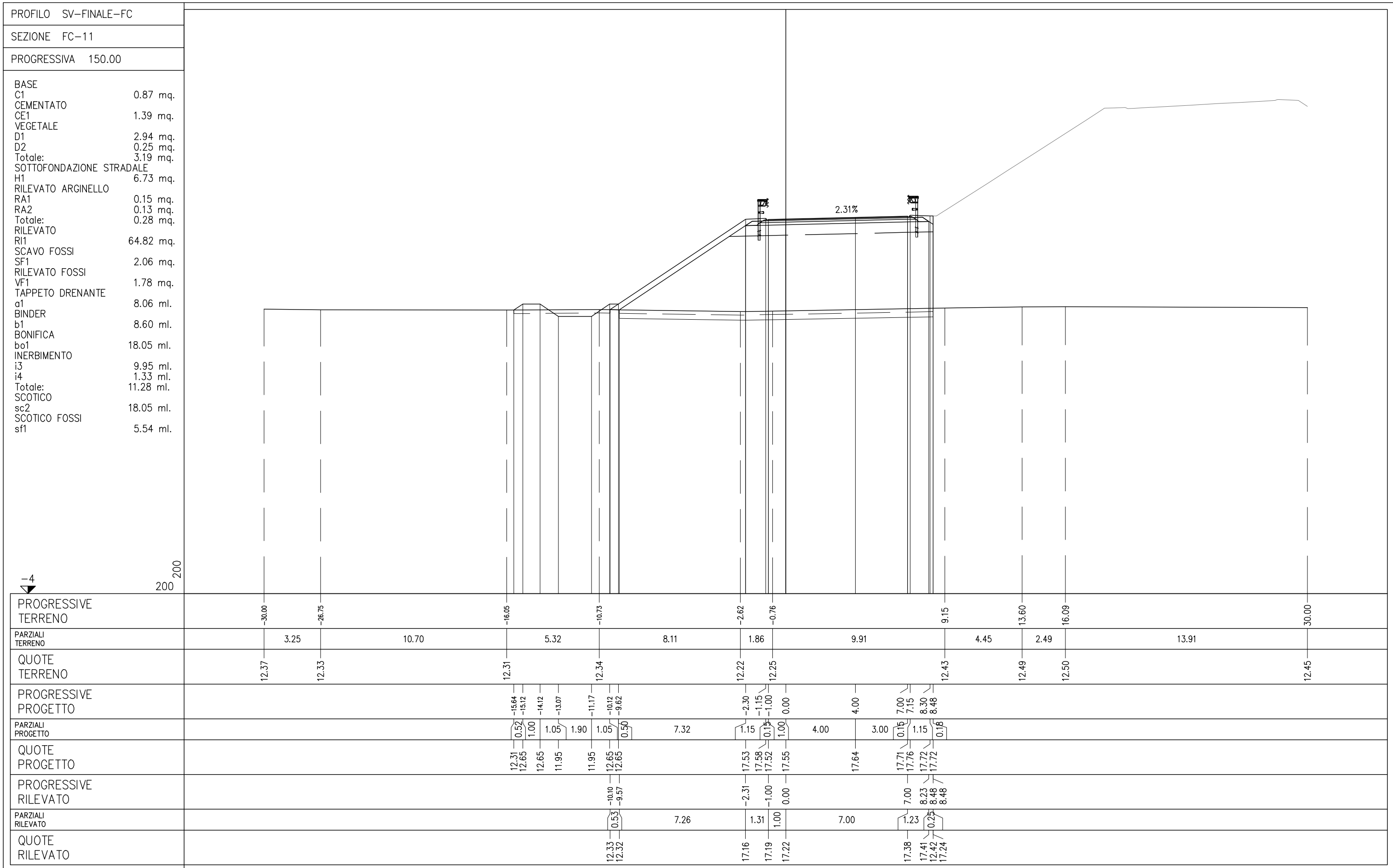

PROFILO SV-FINALE-FC
 SEZIONE FC-12
 PROGRESSIVA 175.00

BASE	
C1	0.88 mq.
CEMENTATO	
CE1	1.37 mq.
VEGETALE	
D1	3.52 mq.
D2	0.52 mq.
Totale:	4.04 mq.
SOTTOFONDAZIONE STRADALE	
H1	6.87 mq.
RILEVATO ARGINELLO	
RA1	0.16 mq.
RA2	0.12 mq.
Totale:	0.28 mq.
RILEVATO	
RI1	105.42 mq.
RIEMPIMENTO	
RP1	3.00 mq.
SCAVO FOSSI	
SF1	2.06 mq.
RILEVATO FOSSI	
VF1	1.37 mq.
TAPPETO DRENANTE	
a1	8.06 ml.
BINDER	
b1	8.60 ml.
BONIFICA	
bo1	23.21 ml.
INERBIMENTO	
i3	5.09 ml.
i4	12.16 ml.
Totale:	17.25 ml.
SCOTICO	
sc2	23.21 ml.
SCOTICO FOSSI	
sf1	5.62 ml.

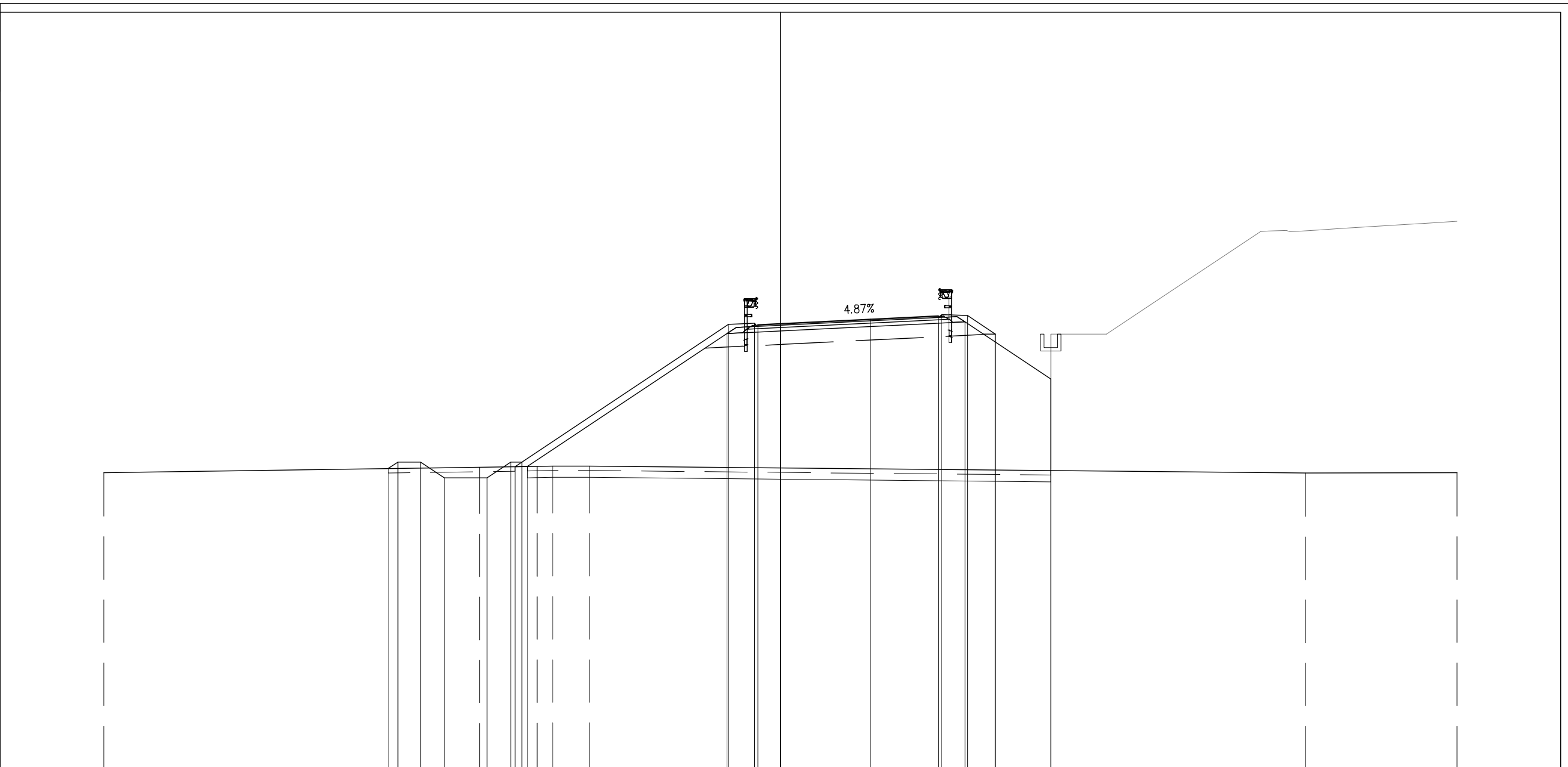

PROGRESSIVE TERRENO	-30.00		-13.34	-10.79	-10.10	-8.47		23.29	30.00												
PARZIALI TERRENO	16.66		2.55	0.69	1.63		31.76	6.71													
QUOTE TERRENO	12.18		12.42	12.46	12.47	12.47		12.16	12.18												
PROGRESSIVE PROGETTO		-17.39	-16.96	-15.96	-14.91	-13.01	-11.96	-11.46		-2.30	-1.15	-1.00	0.00	4.00	4.00	7.00	7.15	8.30	9.53	11.99	
PARZIALI PROGETTO		0.43	1.00	1.05	1.90	1.05	0.50		9.16	1.15	0.15	1.00	4.00	3.00	0.15	1.15	1.23	2.46			
QUOTE PROGETTO		12.36	12.65	12.65	11.95	11.95	12.65	12.65		18.76	18.80	18.75	18.80	18.99	19.14	19.19	19.15	18.33		18.33	
PROGRESSIVE RILEVATO							-11.77	-11.22		-2.37	-1.00	0.00			7.00	8.18				11.99	11.99
PARZIALI RILEVATO							0.55		8.85	1.37	1.00		7.00		1.18		3.81				
QUOTE RILEVATO							12.44	12.45		18.35	18.42	18.47			18.81	18.86				12.27	16.33

PROFILO SV-FINALE-FC
 SEZIONE FC-13
 PROGRESSIVA 195.73

BASE	
C1	0.96 mq.
CEMENTATO	
CE1	1.50 mq.
VEGETALE	
D1	4.76 mq.
D2	1.17 mq.
Totale:	5.93 mq.
SOTTOFONDAZIONE STRADALE	
H1	7.42 mq.
RILEVATO ARGINELLO	
RA1	0.18 mq.
RA2	0.11 mq.
Totale:	0.29 mq.
RILEVATO	
RI1	148.70 mq.
RIEMPIMENTO	
RP1	2.65 mq.
SCAVO FOSSI	
SF1	2.06 mq.
RILEVATO FOSSI	
VF1	2.61 mq.
TAPPETO DRENANTE	
a1	8.96 ml.
BINDER	
b1	9.50 ml.
BONIFICA	
bo1	29.49 ml.
INERBIMENTO	
i3	15.84 ml.
i4	7.11 ml.
Totale:	22.95 ml.
SCOTICO	
sc2	29.49 ml.
SCOTICO FOSSI	
sf1	5.59 ml.

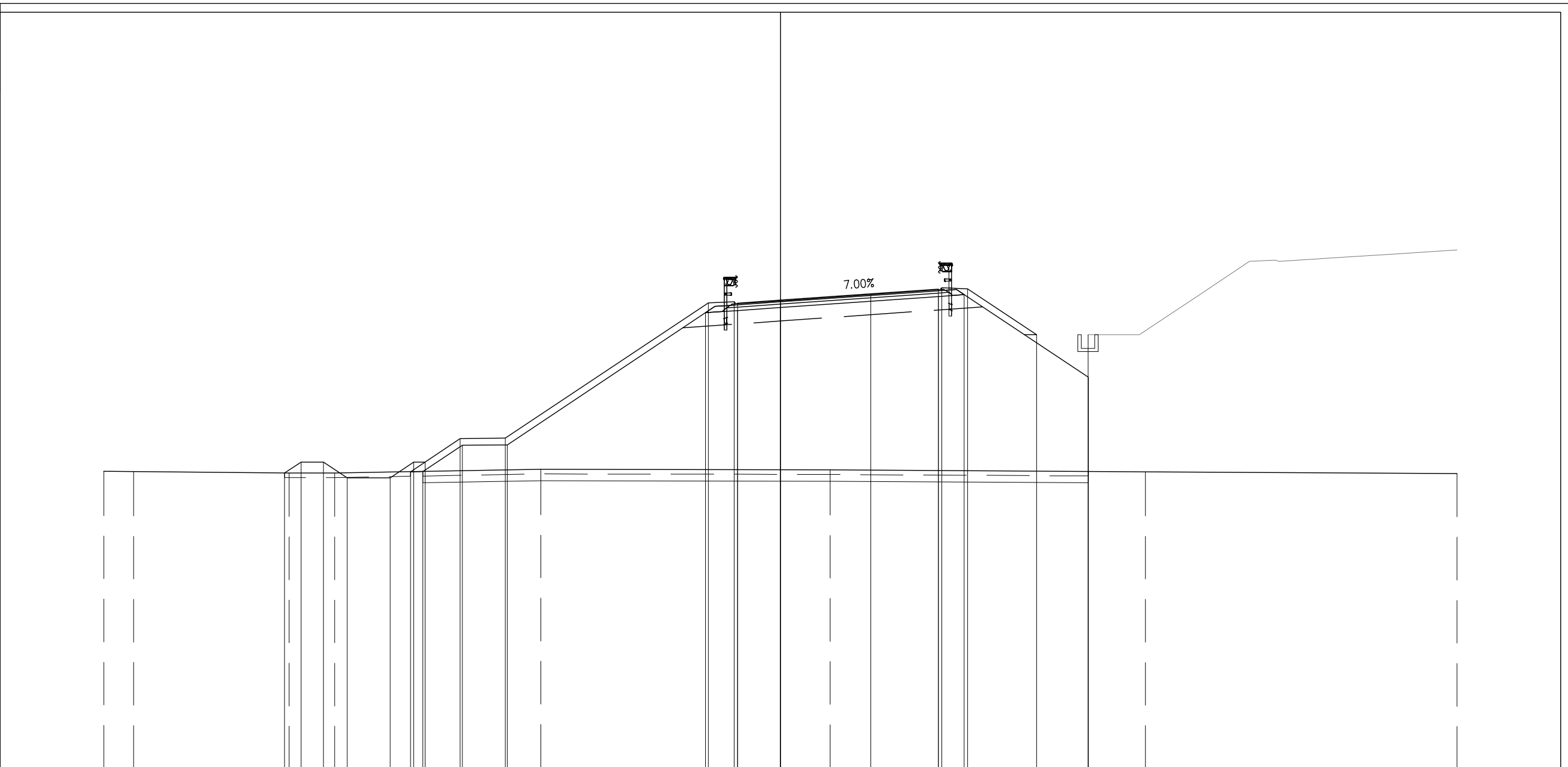

PROGRESSIVE TERRENO	-30.00	-28.68	-21.79	-19.76	-10.63	2.21	16.18	30.00														
PARZIALI TERRENO	1.32	6.89	2.03	9.13	12.84	13.97	13.82															
QUOTE TERRENO	12.24	12.22	12.16	12.16	12.32	12.30	12.22	12.13														
PROGRESSIVE PROGETTO			-22.00	-21.26	-20.26	-19.21	-17.31	-16.26	-15.76	-14.20	-12.20	-3.20	-2.05	-1.90	0.00	4.00	4.00	7.00	7.15	8.30	11.36	13.64
PARZIALI PROGETTO			0.74	1.00	1.05	1.90	1.05	0.50	1.56	2.00	9.00	1.15	0.15	1.90	4.00	3.00	0.15	1.15	3.06	2.28		
QUOTE PROGETTO			12.16	12.65	12.65	11.95	11.95	12.65	12.65	13.69	13.71	19.71	19.76	19.70	19.83	20.11	20.32	20.38	20.33	18.29	18.29	
PROGRESSIVE RILEVATO								-16.41	-15.85	-14.11	-12.11	-3.32	-1.90	0.00	7.00	8.15	13.64	13.64				
PARZIALI RILEVATO								0.56	1.74	2.00	8.79	1.42	1.90	7.00	1.15	5.49						
QUOTE RILEVATO								12.22	12.23	13.39	13.41	19.27	19.37	19.50	19.99	20.07	12.23	16.41				

PROFILO SV-FINALE-FC
 SEZIONE FC-15
 PROGRESSIVA 225.00

BASE	
C1	0.97 mq.
CEMENTATO	
CE1	1.51 mq.
VEGETALE	
D1	1.98 mq.
D2	5.49 mq.
Totale:	7.47 mq.
SOTTOFONDAZIONE STRADALE	
H1	7.44 mq.
RILEVATO ARGINELLO	
RA1	0.17 mq.
RA2	0.12 mq.
Totale:	0.29 mq.
RILEVATO	
RI1	201.51 mq.
RIEMPIMENTO	
RP1	1.67 mq.
SCAVO FOSSI	
SF1	2.05 mq.
RILEVATO FOSSI	
VF1	1.78 mq.
TAPPETO DRENANTE	
a1	8.96 ml.
BINDER	
b1	9.50 ml.
BONIFICA	
bo1	33.24 ml.
INERBIMENTO	
i3	18.48 ml.
i4	9.26 ml.
Totale:	27.74 ml.
SCOTICO	
sc2	33.24 ml.
SCOTICO FOSSI	
sf1	5.47 ml.

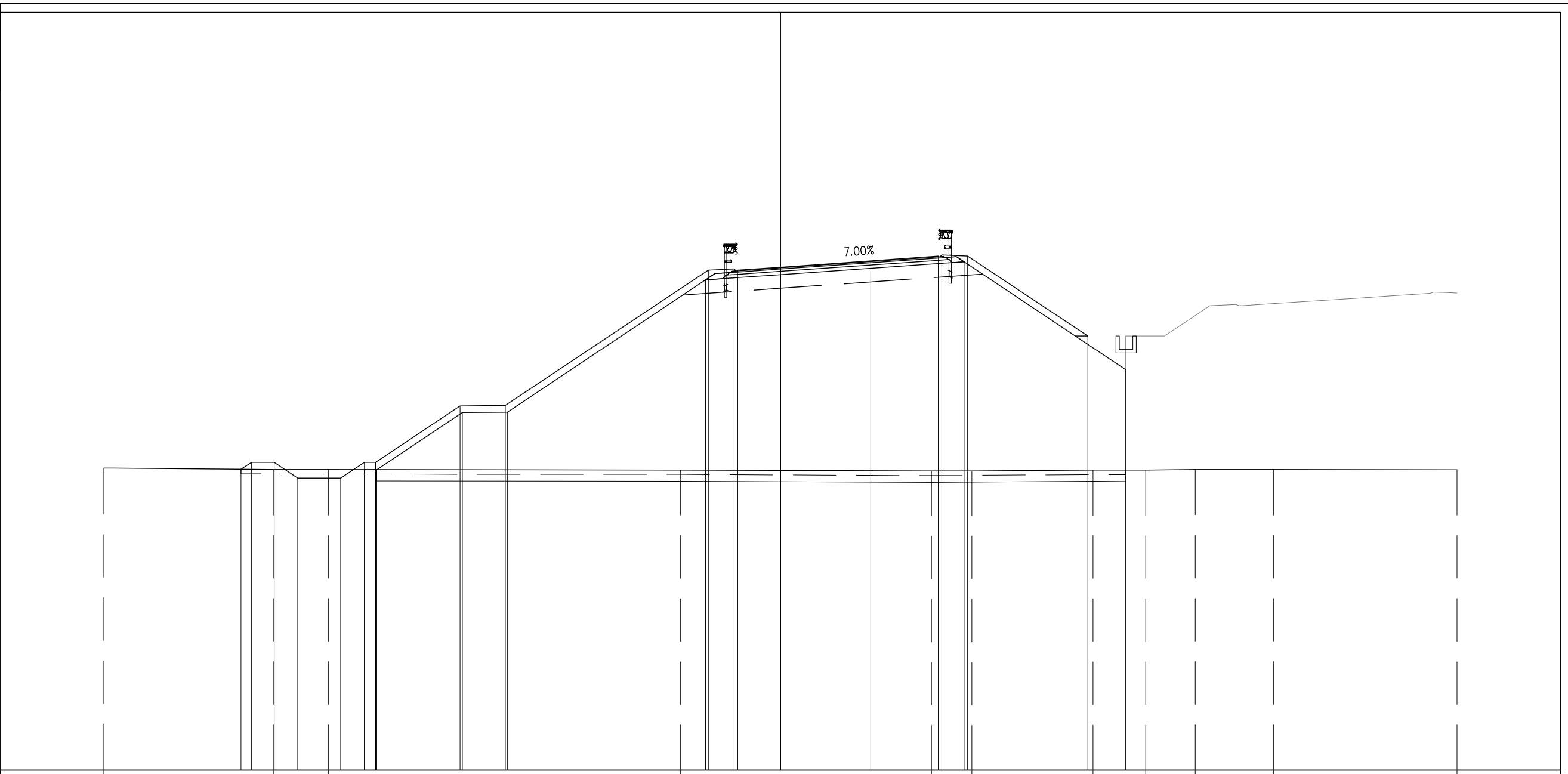

PROGRESSIVE TERRENO	-30.00		-22.48	-20.05		-4.43		6.70	8.49	13.87	16.19	18.39	21.86	30.00								
PARZIALI TERRENO		7.52		2.43		15.62		11.13		1.79	5.38	2.32	2.20	3.47	8.14							
QUOTE TERRENO	12.40		12.33	12.32		12.31		12.26	12.26	12.30	12.30	12.33	12.33	12.32								
PROGRESSIVE PROGETTO			-23.92	-23.45	-22.45	-21.40	-19.50	-18.45	-17.95		-14.20	-12.20										
PARZIALI PROGETTO			0.47	1.00	1.05	1.90	1.05	0.50	3.75	2.00	9.00	1.15	0.15	1.90	4.00	4.00	3.00	7.00	7.15	8.30	13.63	15.33
QUOTE PROGETTO			12.34	12.65	12.65	11.95	11.95	12.65	12.65	3.75	2.00	9.00	21.17	21.22	21.16	21.30	21.58	21.79	21.84	21.80	18.24	18.24
PROGRESSIVE RILEVATO							-18.45	-17.91		-14.11	-12.11											
PARZIALI RILEVATO							0.51	3.80	2.00	8.79	1.42	1.90	7.00	1.15	7.18					15.33	15.33	
QUOTE RILEVATO							12.32	12.32	14.85	14.87	8.79	20.73	20.83	20.97	21.46	21.54				12.30	16.75	

PROFILO SV-FINALE-FC
 SEZIONE FC-17
 PROGRESSIVA 274.84

- BASE
- C1 0.89 mq.
- CEMENTATO
- CE1 1.34 mq.
- SOTTOFONDAZIONE STRADALE
- H1 5.34 mq.
- RILEVATO
- RI1 89.73 mq.
- TAPPETO DRENANTE
- a1 8.90 ml.
- BINDER
- b1 8.90 ml.
- BONIFICA
- bo1 8.90 ml.
- SCOTICO
- sc1 8.90 ml.

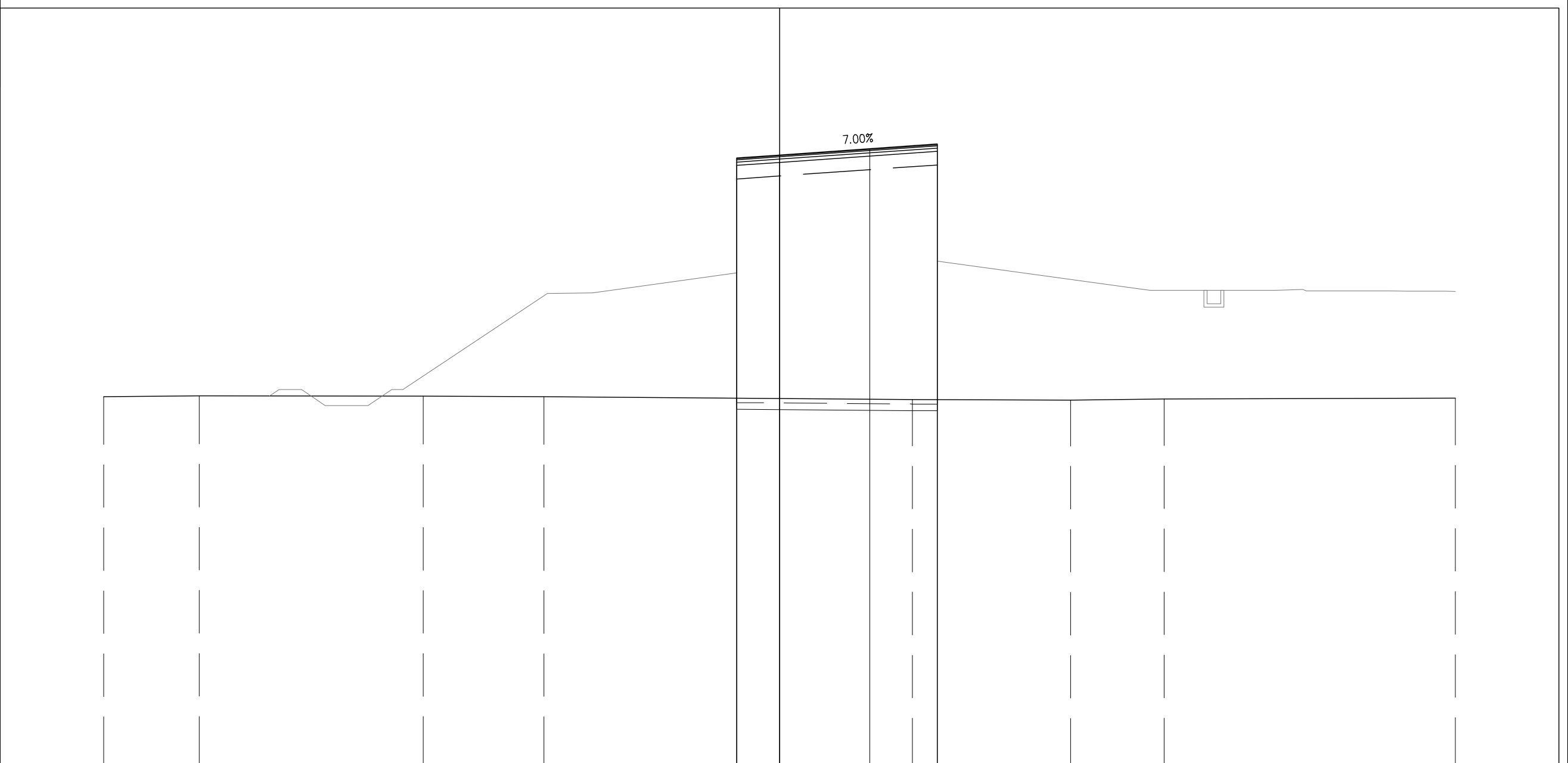

PROGRESSIVE TERRENO	-30.00	-25.77	-15.82	-10.45		5.89	12.92	17.08	30.00
PARZIALI TERRENO	4.23	9.95	5.37	16.34		7.03	4.16	12.92	
QUOTE TERRENO	12.34	12.37	12.36	12.34		12.21	12.19	12.23	12.27
PROGRESSIVE PROGETTO					-1.90	0.00	4.00	7.00	
PARZIALI PROGETTO					1.90	4.00	3.00		
QUOTE PROGETTO					22.94	23.07	23.35	23.56	
PROGRESSIVE RILEVATO					-1.90	0.00	7.00	7.00	
PARZIALI RILEVATO					1.90	7.00			
QUOTE RILEVATO					22.61	22.74	23.23	23.23	

PROFILO SV-FINALE-FC
 SEZIONE FC-18SPA
 PROGRESSIVA 275.51

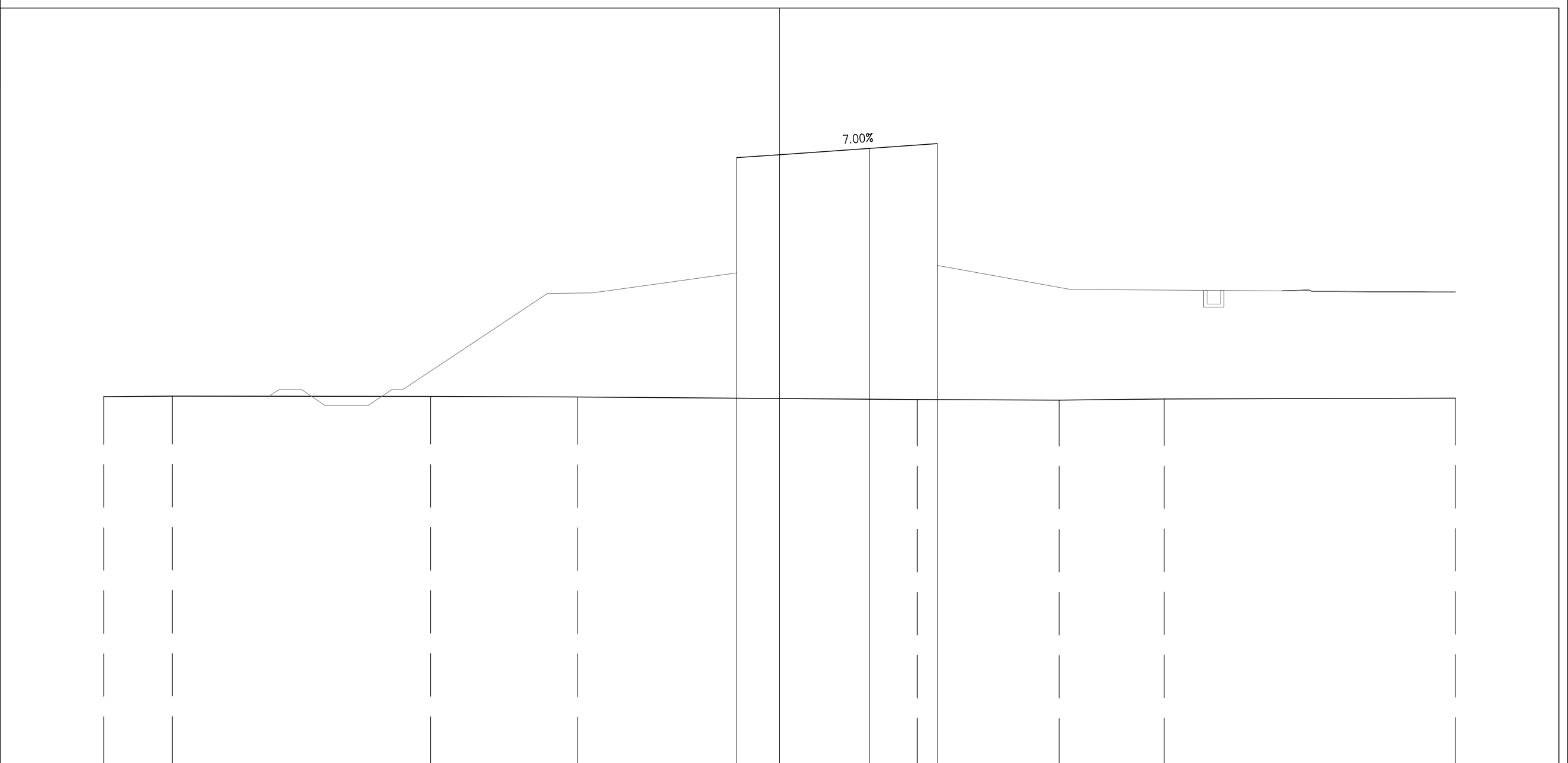

PROGRESSIVE TERRENO	-30.00	-26.95	-15.49	-8.97	6.12	12.41	17.08	30.00
PARZIALI TERRENO	3.05	11.46	6.52	15.09	6.29	4.67	12.92	
QUOTE TERRENO	12.34	12.37	12.36	12.33	12.21	12.19	12.24	12.28
PROGRESSIVE PROGETTO					-1.90	0.00	4.00	7.00
PARZIALI PROGETTO					1.90	4.00	3.00	
QUOTE PROGETTO					22.95	23.08	23.36	23.57
PROGRESSIVE RILEVATO								
PARZIALI RILEVATO								
QUOTE RILEVATO								

PROFILO SV-FINALE-FC
 SEZIONE FC-24
 PROGRESSIVA 365.38

- BASE
- C1 0.85 mq.
- CEMENTATO
- CE1 1.28 mq.
- SOTTOFONDAZIONE STRADALE
- H1 5.11 mq.
- RILEVATO
- RI1 81.01 mq.
- TAPPETO DRENANTE
- a1 8.51 ml.
- BINDER
- b1 8.51 ml.
- BONIFICA
- bo1 8.51 ml.
- SCOTICO
- sc1 8.51 ml.

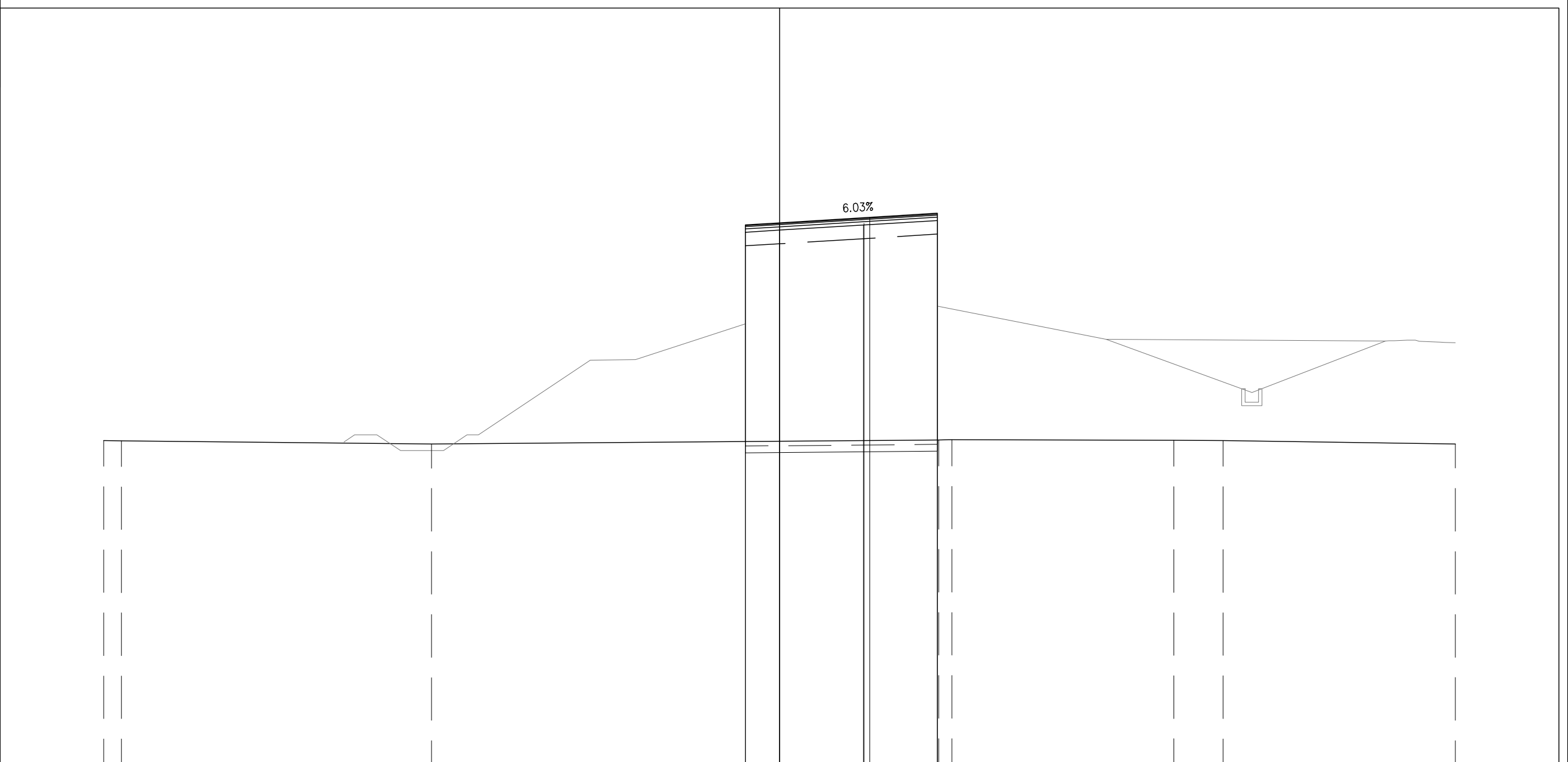

PROGRESSIVE TERRENO	-30.00	-29.21		-15.45				7.06	7.65		17.51	19.68		30.00
PARZIALI TERRENO	0.79		13.76			22.51		0.59		9.86	2.17		10.32	
QUOTE TERRENO	12.39	12.38		12.24				12.42	12.43		12.41	12.40		12.24
PROGRESSIVE PROGETTO						-1.51	0.00	3.73	3.75	4.00	7.00			
PARZIALI PROGETTO						1.51		4.00	0.02		3.00			
QUOTE PROGETTO						21.98	22.07	21.96	22.03	22.31	22.49			
PROGRESSIVE RILEVATO						-1.51	0.00				7.00			
PARZIALI RILEVATO						1.51		7.00						
QUOTE RILEVATO	21.65	12.35		21.74				12.42	22.16					

PROFILO SV-FINALE-FC
 SEZIONE FC-25
 PROGRESSIVA 375.00

BASE	
C1	0.89 mq.
CEMENTATO	
CE1	1.38 mq.
VEGETALE	
D1	2.78 mq.
D2	5.71 mq.
Totale:	8.49 mq.
SOTTOFONDAZIONE STRADALE	
H1	6.93 mq.
RILEVATO ARGINELLO	
RA1	0.16 mq.
RA2	0.13 mq.
Totale:	0.29 mq.
RILEVATO	
RI1	216.96 mq.
RIEMPIMENTO	
RP1	3.39 mq.
SCAVO FOSSI	
SF1	2.06 mq.
RILEVATO FOSSI	
VF1	1.82 mq.
TAPPETO DRENANTE	
a1	8.15 ml.
BINDER	
b1	8.69 ml.
BONIFICA	
bo1	36.18 ml.
INERBIMENTO	
i3	19.25 ml.
i4	12.76 ml.
Totale:	32.01 ml.
SCOTICO	
sc2	36.18 ml.
SCOTICO FOSSI	
sf1	5.44 ml.

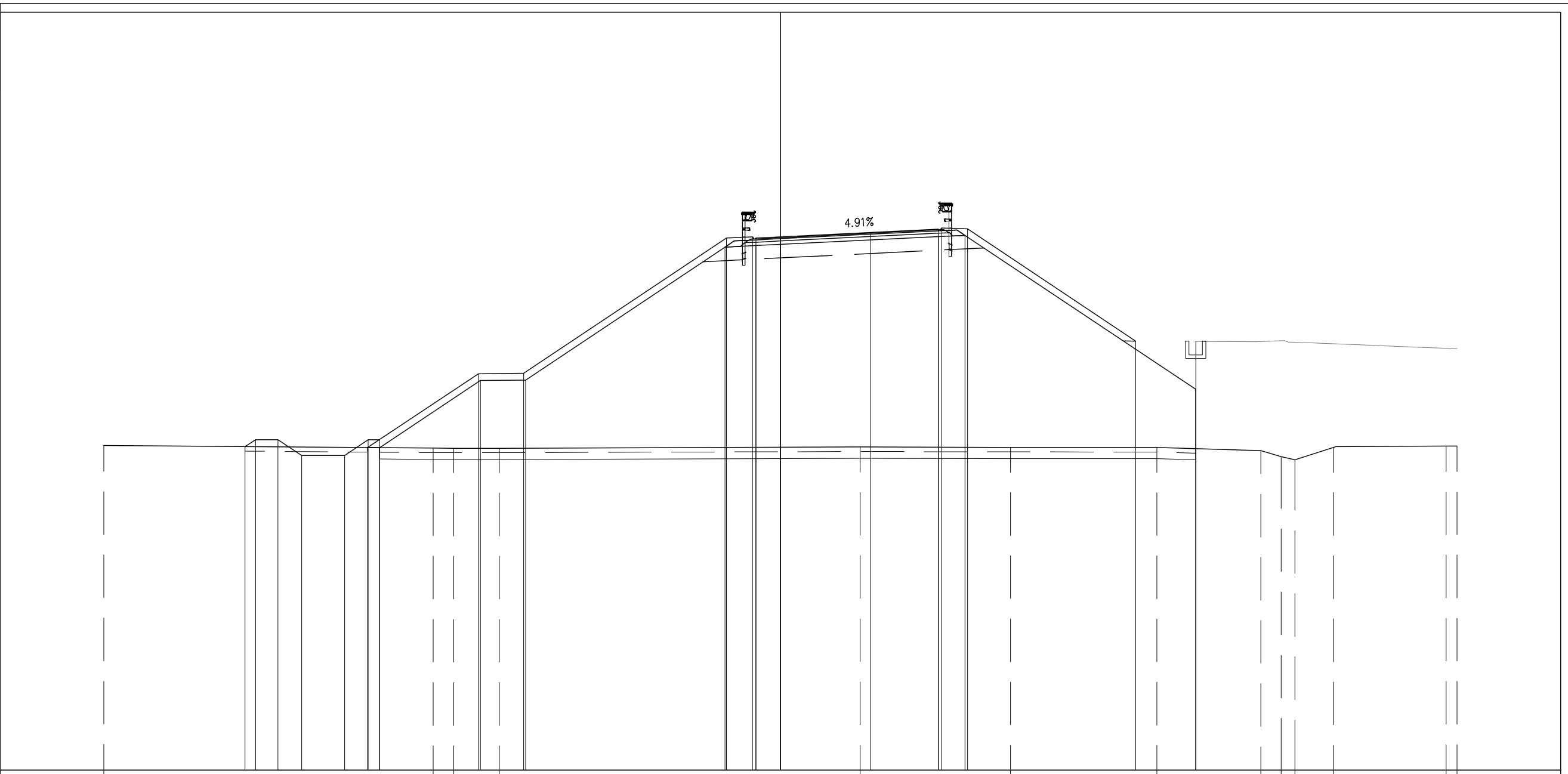

PROGRESSIVE TERRENO	-30.00				-15.40	-14.49	-12.47			3.53		10.20		16.69		21.30	22.20	22.82	24.52		29.52	30.00
PARZIALI TERRENO		14.60			0.91	2.02		16.00		6.67		6.49		4.61		0.90	0.62	1.70		5.00	0.48	
QUOTE TERRENO	12.39				12.28	12.27	12.27			12.33		12.31		12.30		12.17	11.90	11.75	12.31		12.37	12.38
PROGRESSIVE PROGETTO			-23.74	-23.28	-22.28	-21.23	-19.33	-18.28	-17.78		-2.39	-1.24	-1.09	0.00		4.00	7.00	7.15	8.30		15.76	18.41
PARZIALI PROGETTO		0.46	1.00	1.05	1.90	1.05	0.50	4.39	2.00	9.00	1.15	0.15	1.15	7.46	2.65							
QUOTE PROGETTO		12.34	12.65	12.65	11.95	11.95	12.65	12.65			21.60	21.64	21.59	21.64		21.84	21.98	22.04	21.99		17.02	17.01
PROGRESSIVE RILEVATO							-18.30	-17.77			-2.46	-1.09	0.00				7.00	8.18			18.41	18.41
PARZIALI RILEVATO							0.53	4.47	2.00	8.84	1.37	1.09	7.00	1.18	10.23							
QUOTE RILEVATO							12.30	12.30			15.28	15.30					21.65	21.71			12.25	14.89

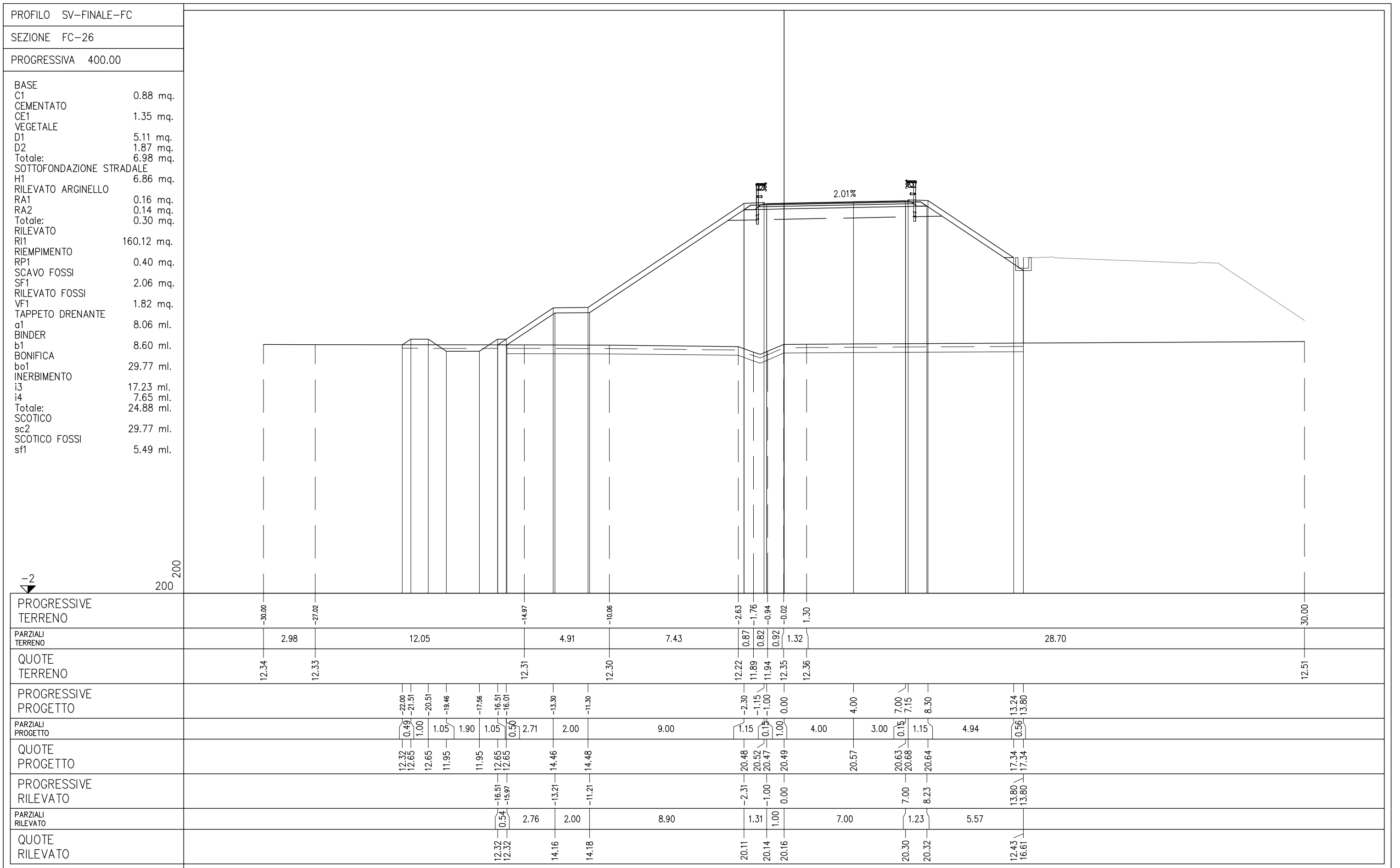

PROFILO SV-FINALE-FC
 SEZIONE FC-27
 PROGRESSIVA 425.88

BASE	
C1	0.86 mq.
CEMENTATO	
CE1	1.38 mq.
VEGETALE	
D1	4.00 mq.
D2	1.10 mq.
Totale:	5.10 mq.
SOTTOFONDAZIONE STRADALE	
H1	6.85 mq.
RILEVATO ARGINELLO	
RA1	0.15 mq.
RA2	0.16 mq.
Totale:	0.31 mq.
RILEVATO	
RI1	117.87 mq.
RIEMPIMENTO	
RP1	0.95 mq.
SCAVO FOSSI	
SF1	2.05 mq.
RILEVATO FOSSI	
VF1	2.38 mq.
TAPPETO DRENANTE	
a1	8.06 ml.
BINDER	
b1	8.60 ml.
BONIFICA	
bo1	24.83 ml.
INERBIMENTO	
i3	13.63 ml.
i4	5.68 ml.
Totale:	19.31 ml.
SCOTICO	
sc2	24.83 ml.
SCOTICO FOSSI	
sf1	5.86 ml.

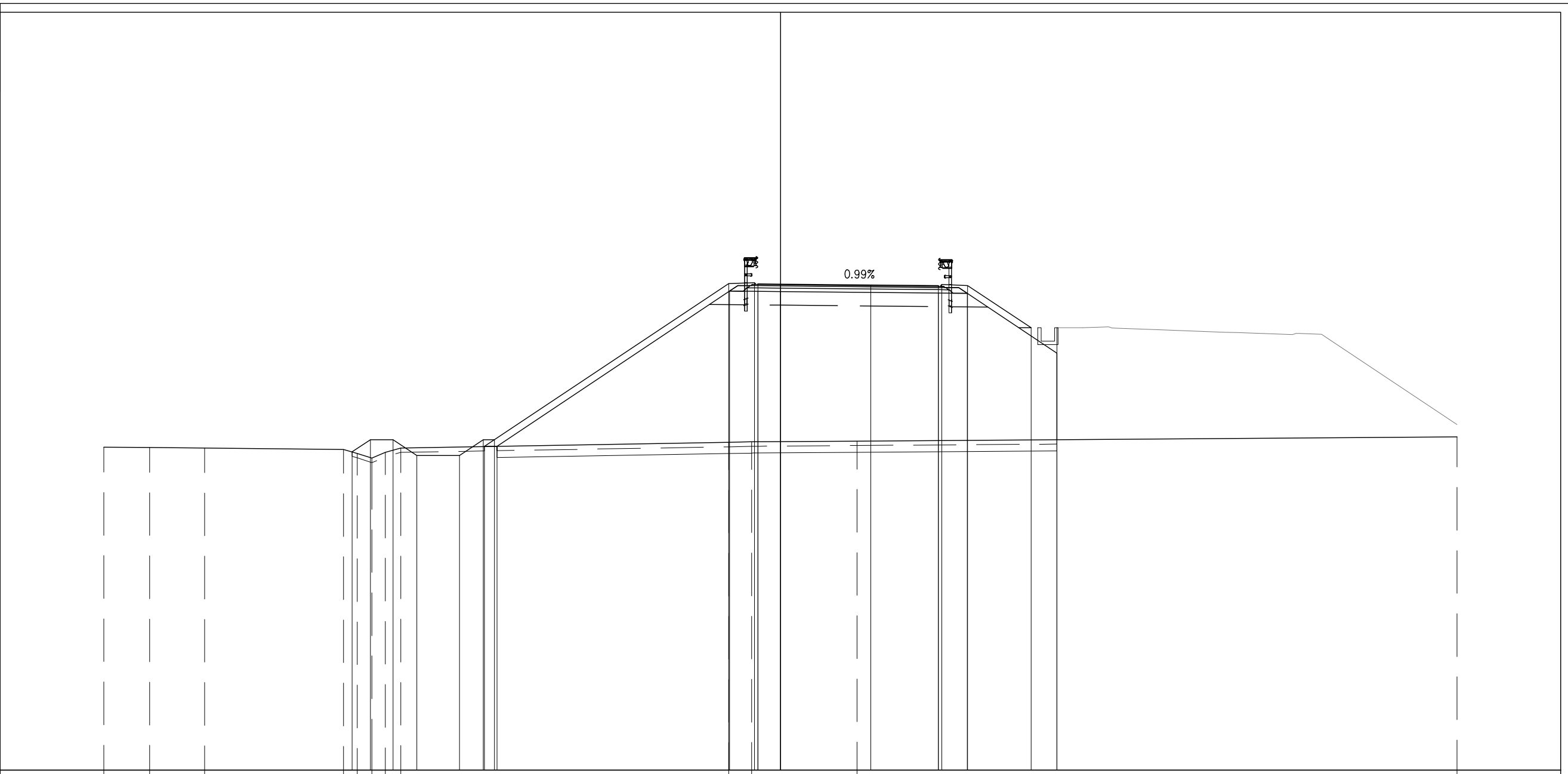

PROGRESSIVE TERRENO	-30.00	-27.97	-25.54	-19.38	-18.76	-18.12	-17.52	-16.83	-2.29	-1.28	3.40	30.00									
PARZIALI TERRENO	2.03	2.43	6.16	0.62	0.64	0.60	0.69	14.54	1.01	4.68	26.60										
QUOTE TERRENO	12.32	12.31	12.28	12.22	12.04	11.83	12.09	12.29	12.54	12.56	12.59	12.78									
PROGRESSIVE PROGETTO				-18.99	-18.18	-17.18	-16.13	-14.23	-13.18	-12.88	-2.30	-1.15	-1.00	0.00	4.00	4.00	7.00	7.15	8.30	11.11	12.26
PARZIALI PROGETTO				0.81	1.00	1.05	1.90	1.05	10.38	1.15	0.15	1.00	4.00	3.00	0.15	1.15	2.81	1.15			
QUOTE PROGETTO				12.11	12.65	12.65	11.95	11.95	12.65	12.65	19.57	19.61	19.56	19.55	19.51	19.48	19.53	19.49	17.61	17.61	
PROGRESSIVE RILEVATO																					
PARZIALI RILEVATO									10.32												
QUOTE RILEVATO									12.35	12.36	19.24	19.23	19.22	19.14	19.15	19.14				12.65	16.49

PROFILO SV-FINALE-FC
 SEZIONE FC-28
 PROGRESSIVA 427.32

BASE	
C1	0.88 mq.
CEMENTATO	
CE1	1.37 mq.
VEGETALE	
D1	3.99 mq.
D2	1.06 mq.
Totale:	5.05 mq.
SOTTOFONDAZIONE STRADALE	
H1	6.86 mq.
RILEVATO ARGINELLO	
RA1	0.14 mq.
RA2	0.16 mq.
Totale:	0.30 mq.
RILEVATO	
RI1	116.22 mq.
RIEMPIMENTO	
RP1	1.02 mq.
SCAVO FOSSI	
SF1	2.05 mq.
RILEVATO FOSSI	
VF1	2.09 mq.
TAPPETO DRENANTE	
a1	8.06 ml.
BINDER	
b1	8.60 ml.
BONIFICA	
bo1	24.71 ml.
INERBIMENTO	
i3	13.54 ml.
i4	13.54 ml.
i4	5.61 ml.
Totale:	32.69 ml.
SCOTICO	
sc2	24.71 ml.
SCOTICO FOSSI	
sf1	6.19 ml.

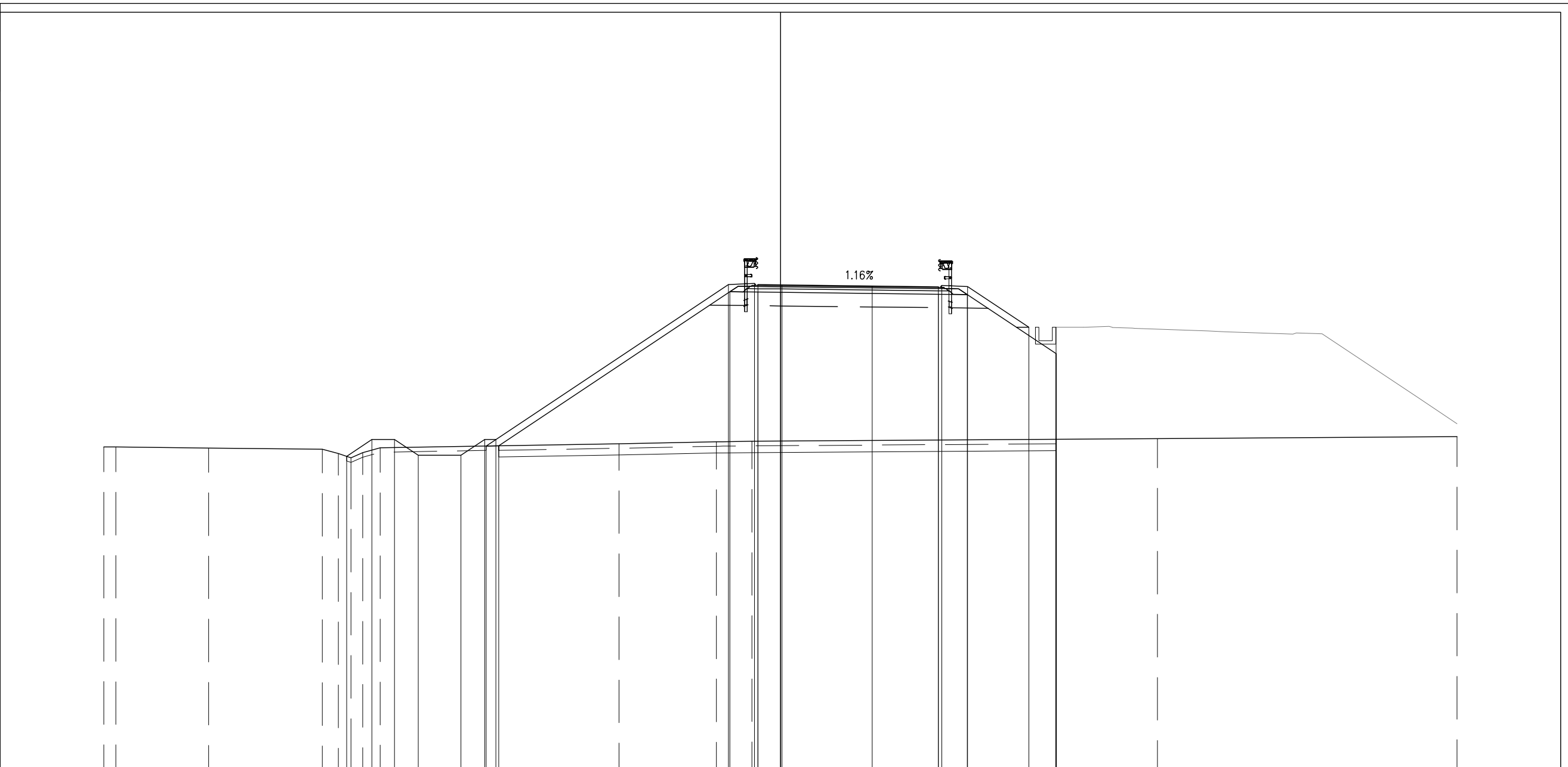

PROGRESSIVE TERRENO	-30.00	-29.48	-25.35	-20.31	-19.61	-19.04	-18.52	-17.75	-7.15	-2.84	-1.26	16.72	30.00							
PARZIALI TERRENO	0.52	4.13	5.04	0.70	0.57	0.52	0.77	10.60	4.31	1.58	17.98	13.28								
QUOTE TERRENO	12.32	12.32	12.27	12.22	12.02	11.83	12.06	12.28	12.46	12.55	12.57	12.69	12.78							
PROGRESSIVE PROGETTO				-19.24	-18.11	-17.11	-16.06	-14.16	-13.11	-12.61	-2.30	-1.15	-1.00	0.06	4.06	7.00	7.15	8.30	11.01	12.22
PARZIALI PROGETTO				1.13	1.00	1.05	1.90	1.05	0.50	10.31	1.15	0.15	1.06	4.00	2.94	0.15	1.15	2.71	1.21	
QUOTE PROGETTO				11.90	12.65	12.65	11.95	11.95	12.65	12.65	19.53	19.57	19.52	19.50	19.46	19.42	19.48	19.43	17.63	17.63
PROGRESSIVE RILEVATO									-13.05	-12.49	-2.25	-1.00	0.00		7.00	8.29		12.22	12.22	
PARZIALI RILEVATO									0.56	10.24	1.25	1.00	7.00	1.29	3.93					
QUOTE RILEVATO									12.36	12.37	19.20	19.19	19.17		19.09	19.08		12.66	16.46	

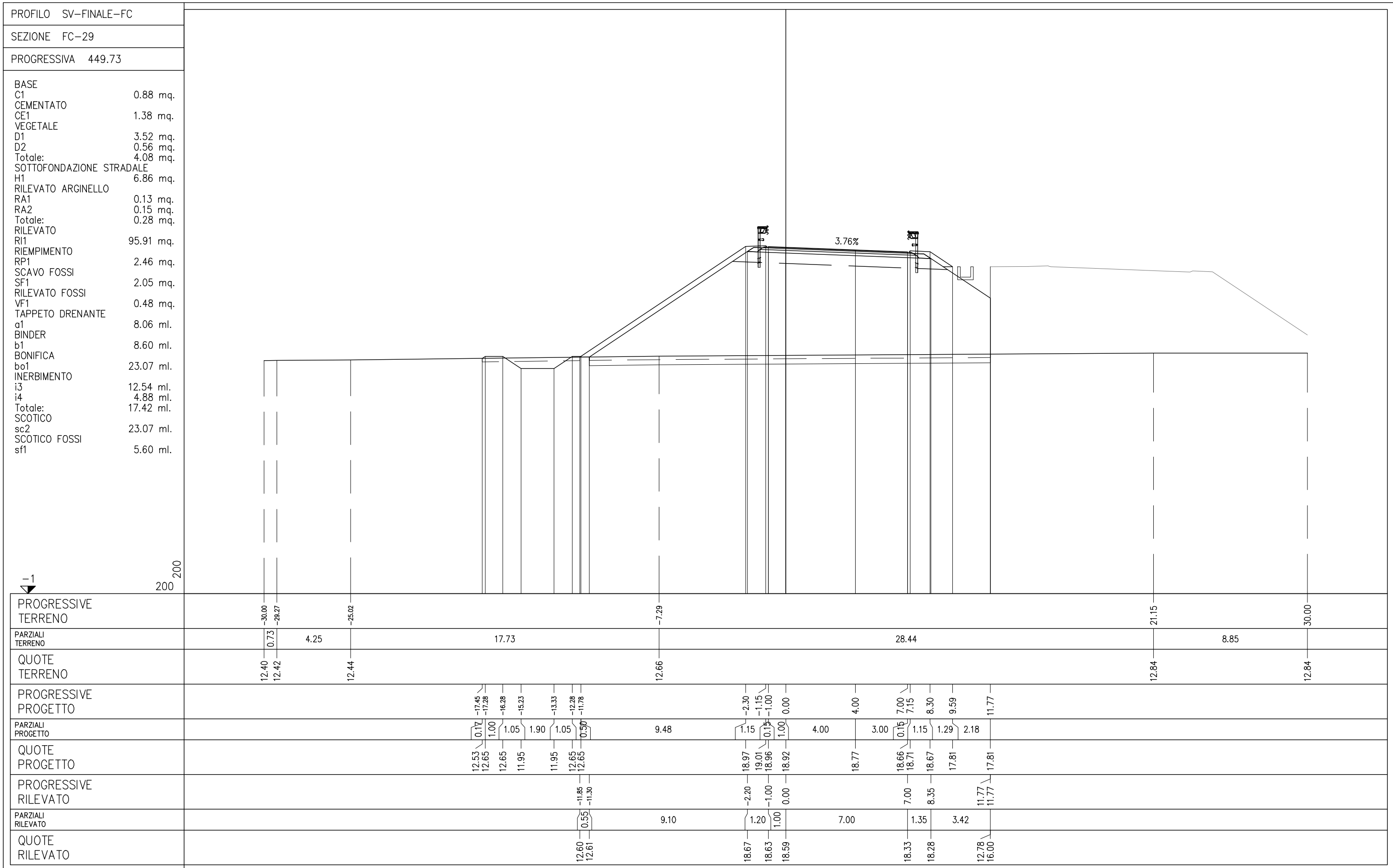

PROFILO SV-FINALE-FC
 SEZIONE FC-30
 PROGRESSIVA 475.00

BASE	
C1	0.90 mq.
CEMENTATO	
CE1	1.36 mq.
VEGETALE	
D1	3.19 mq.
D2	0.28 mq.
Totale:	3.47 mq.
SOTTOFONDAZIONE STRADALE	
H1	6.88 mq.
RILEVATO ARGINELLO	
RA1	0.12 mq.
RA2	0.17 mq.
Totale:	0.29 mq.
RILEVATO	
RI1	80.98 mq.
RIEMPIMENTO	
RP1	2.60 mq.
SCAVO FOSSI	
SF1	3.18 mq.
RILEVATO FOSSI	
VF1	0.69 mq.
TAPPETO DRENANTE	
a1	8.06 ml.
BINDER	
b1	8.60 ml.
BONIFICA	
bo1	21.36 ml.
INERBIMENTO	
i3	11.33 ml.
i4	3.92 ml.
Totale:	15.25 ml.
SCOTICO	
sc2	21.36 ml.
SCOTICO FOSSI	
sf1	6.21 ml.

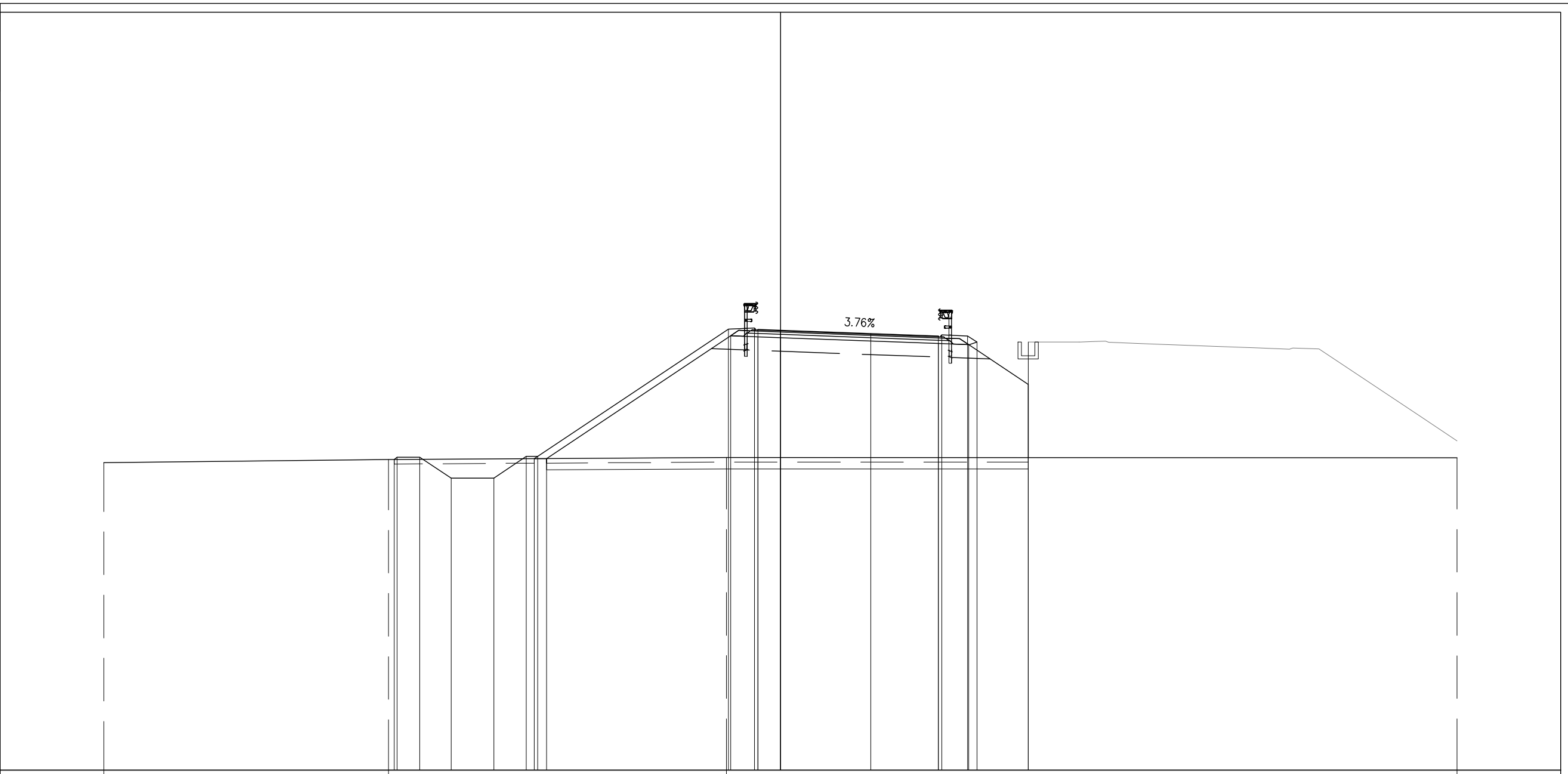

PROGRESSIVE TERRENO	-30.00	-17.38	-2.39	30.00
PARZIALI TERRENO	12.62	14.99	32.39	
QUOTE TERRENO	12.63	12.77	12.86	12.85
PROGRESSIVE PROGETTO		-17.13 -17.00 -16.00 -14.60 -12.70 -11.27 -10.77	-2.30 -1.15 -1.00 0.00	4.00 4.00 7.00 7.15 8.30 8.71 10.99
PARZIALI PROGETTO		0.13 1.00 1.40 1.90 1.43 0.50	8.47	1.15 0.15 1.00 4.00 3.00 0.15 1.15 0.41 2.28
QUOTE PROGETTO		12.77 12.88 12.88 11.95 11.95 12.91 12.91	18.55 18.60 18.54 18.51	18.35 18.24 18.30 18.25 17.98 17.97
PROGRESSIVE RILEVATO			-10.92 -10.37	7.00 8.35 10.99 10.99
PARZIALI RILEVATO			8.17	1.35 2.64
QUOTE RILEVATO		12.81 12.81	18.26 18.21 18.18	17.91 17.86 12.85 16.10

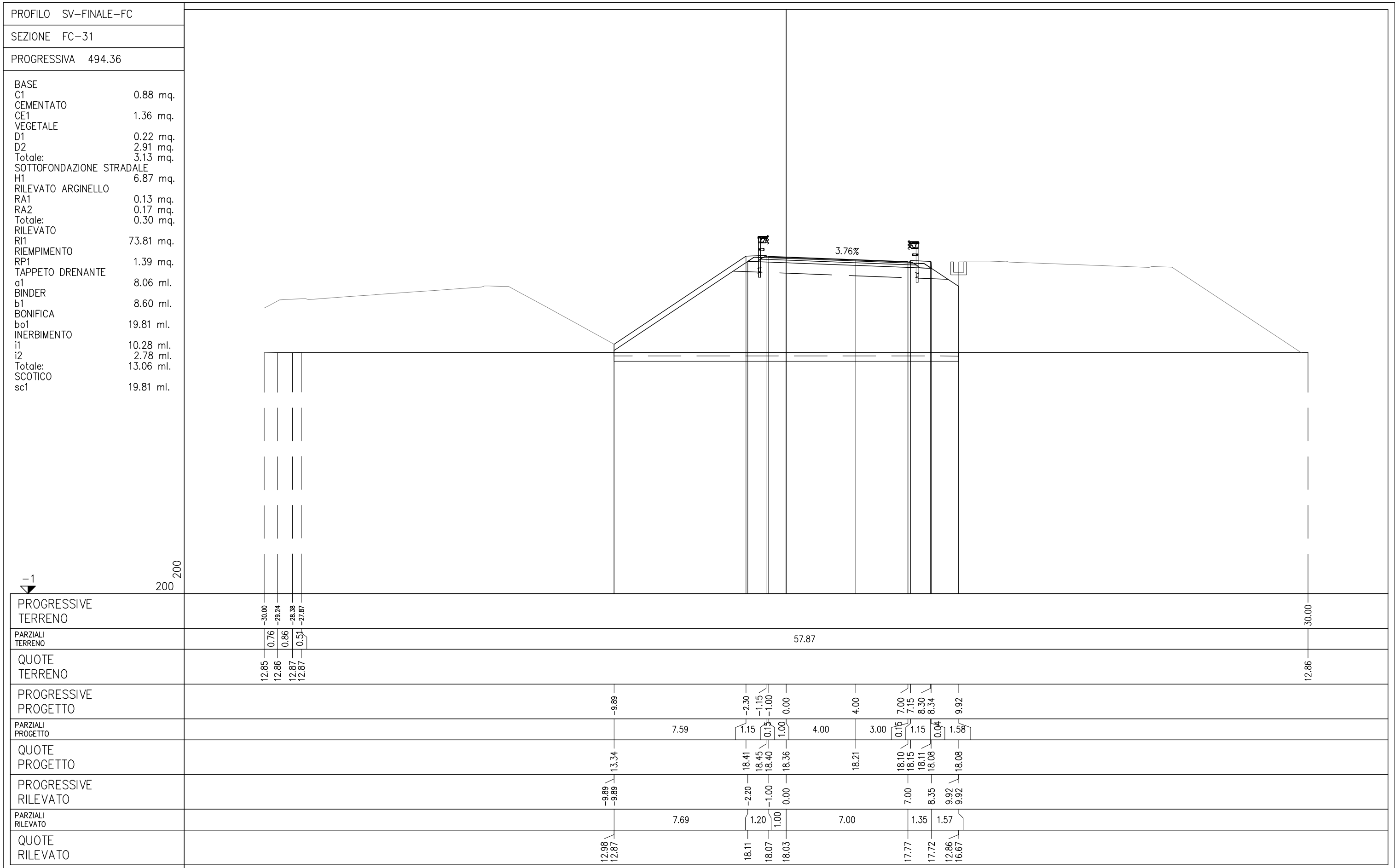

PROFILO SV-FINALE-FC
 SEZIONE FC-32
 PROGRESSIVA 500.00

BASE	
C1	0.87 mq.
CEMENTATO	
CE1	1.36 mq.
VEGETALE	
D1	2.31 mq.
D2	0.21 mq.
Totale:	2.52 mq.
SOTTOFONDAZIONE STRADALE	
H1	6.85 mq.
RILEVATO ARGINELLO	
RA1	0.14 mq.
RA2	0.16 mq.
Totale:	0.30 mq.
RILEVATO	
RI1	70.95 mq.
RIEMPIMENTO	
RP1	0.96 mq.
TAPPETO DRENANTE	
a1	8.06 ml.
BINDER	
b1	8.60 ml.
BONIFICA	
bo1	17.79 ml.
INERBIMENTO	
i1	8.30 ml.
i2	2.39 ml.
Totale:	10.69 ml.
SCOTICO	
sc1	17.79 ml.

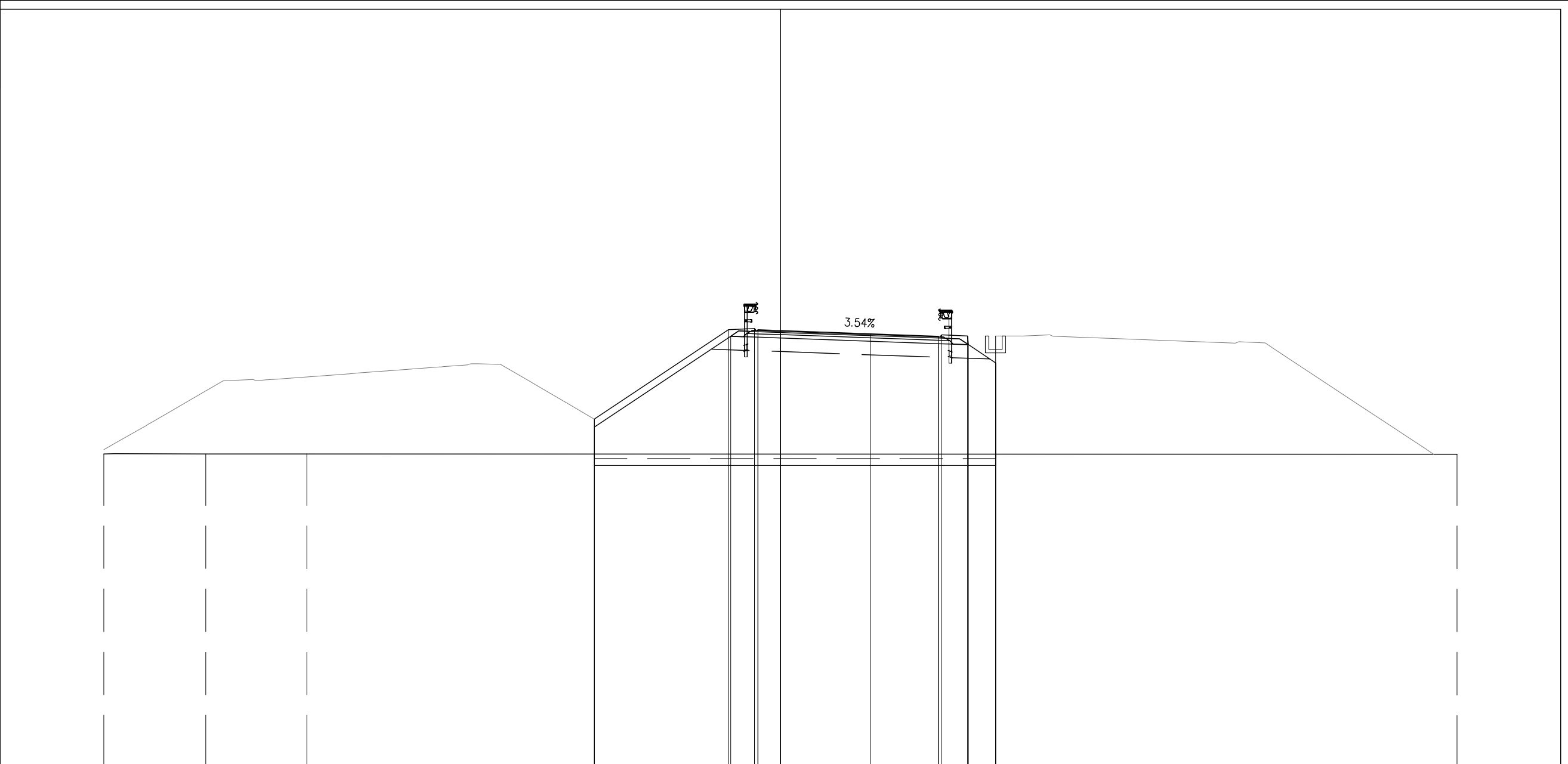

PROGRESSIVE TERRENO	-30.00	-25.48	-21.00									30.00						
PARZIALI TERRENO		4.52	4.48									51.00						
QUOTE TERRENO	12.88	12.88	12.87									12.86						
PROGRESSIVE PROGETTO				-8.25			-2.30	-1.15	-1.00	0.00		4.00	4.00		7.00	7.15	8.30	9.54
PARZIALI PROGETTO				5.95		1.15	0.15	1.00	4.00	3.00	0.15	1.15	1.24					
QUOTE PROGETTO				14.42		18.39	18.44	18.38	18.34	18.20	18.10	18.15	18.11	18.11	18.11	18.11		
PROGRESSIVE RILEVATO				-8.25	-8.25	-2.21	-1.00	0.00			7.00	8.34	9.54	9.54				
PARZIALI RILEVATO				6.04		1.21	1.00	7.00			1.34	1.20						
QUOTE RILEVATO				14.06	12.87	18.09	18.05	18.01			17.77	17.72	12.87	16.92				

PROFILO SV-FINALE-FC	
SEZIONE FC-33	
PROGRESSIVA 527.23	
BASE	
C1	0.88 mq.
CEMENTATO	
CE1	1.37 mq.
VEGETALE	
D1	0.71 mq.
SOTTOFONDAZIONE STRADALE	
H1	6.12 mq.
RILEVATO ARGINELLO	
RA1	0.15 mq.
RILEVATO	
RI1	50.53 mq.
TAPPETO DRENANTE	
a1	8.57 ml.
BINDER	
b1	8.84 ml.
BONIFICA	
bo1	11.35 ml.
INERBIMENTO	
i1	2.97 ml.
SCOTICO	
sc1	11.35 ml.

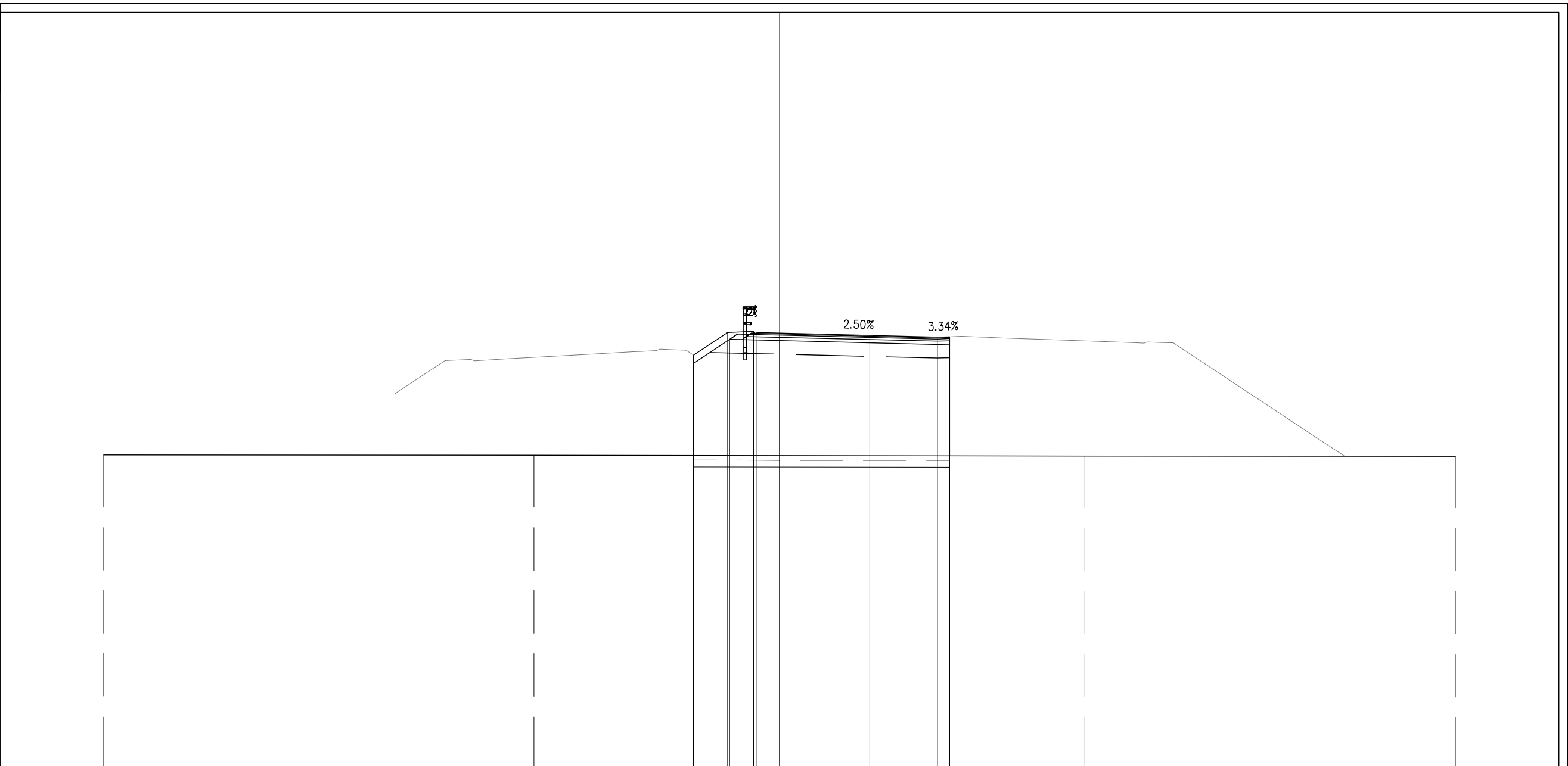

PROGRESSIVE TERRENO	-30.00		-10.90			13.55		30.00				
PARZIALI TERRENO		19.10		24.45		16.45						
QUOTE TERRENO	12.93		12.92			12.88		12.88				
PROGRESSIVE PROGETTO				-3.81	-2.30	-1.15	-1.00	0.00	4.00	4.00	7.00	7.54
PARZIALI PROGETTO				1.51	1.15	0.15	1.00	4.00	3.00	0.54		
QUOTE PROGETTO				17.37	18.38	18.42	18.37	18.34	18.24	18.17	18.19	
PROGRESSIVE RILEVATO				-3.81	-2.22	-1.00	0.00	7.00	7.54	7.54		
PARZIALI RILEVATO				1.59	1.22	1.00	7.00	0.54				
QUOTE RILEVATO	17.01	12.91	18.07	18.04	18.01			17.84	17.86	12.89		

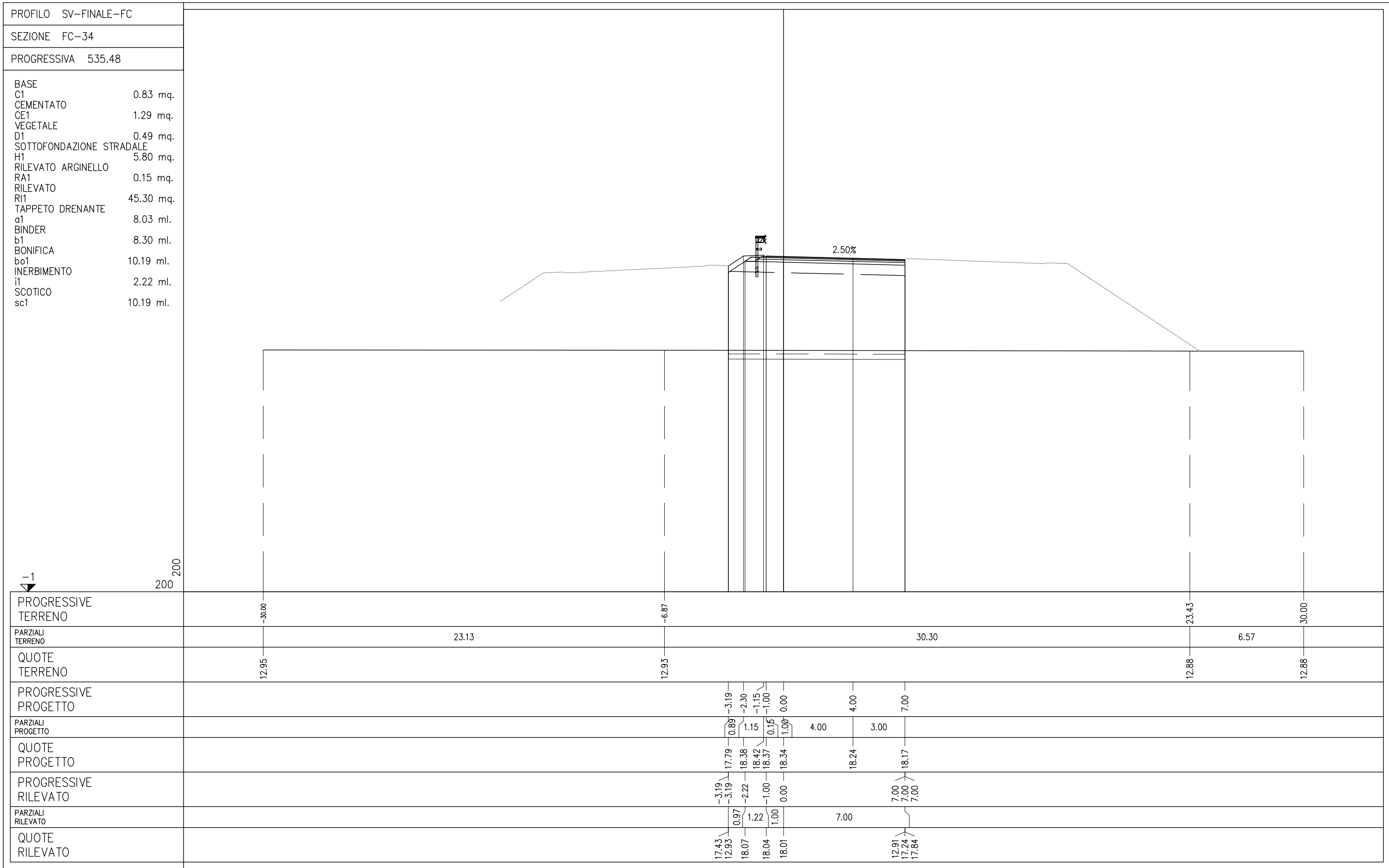

PROFILO SV-FINALE-FC
 SEZIONE FC-35
 PROGRESSIVA 550.00

- BASE
- C1 0.87 mq.
- CEMENTATO
- CE1 1.33 mq.
- SOTTOFONDAZIONE STRADALE
- H1 5.30 mq.
- RILEVATO
- RI1 38.86 mq.
- TAPPETO DRENANTE
- a1 8.83 ml.
- BINDER
- b1 8.83 ml.
- BONIFICA
- bo1 8.83 ml.
- SCOTICO
- sc1 8.83 ml.

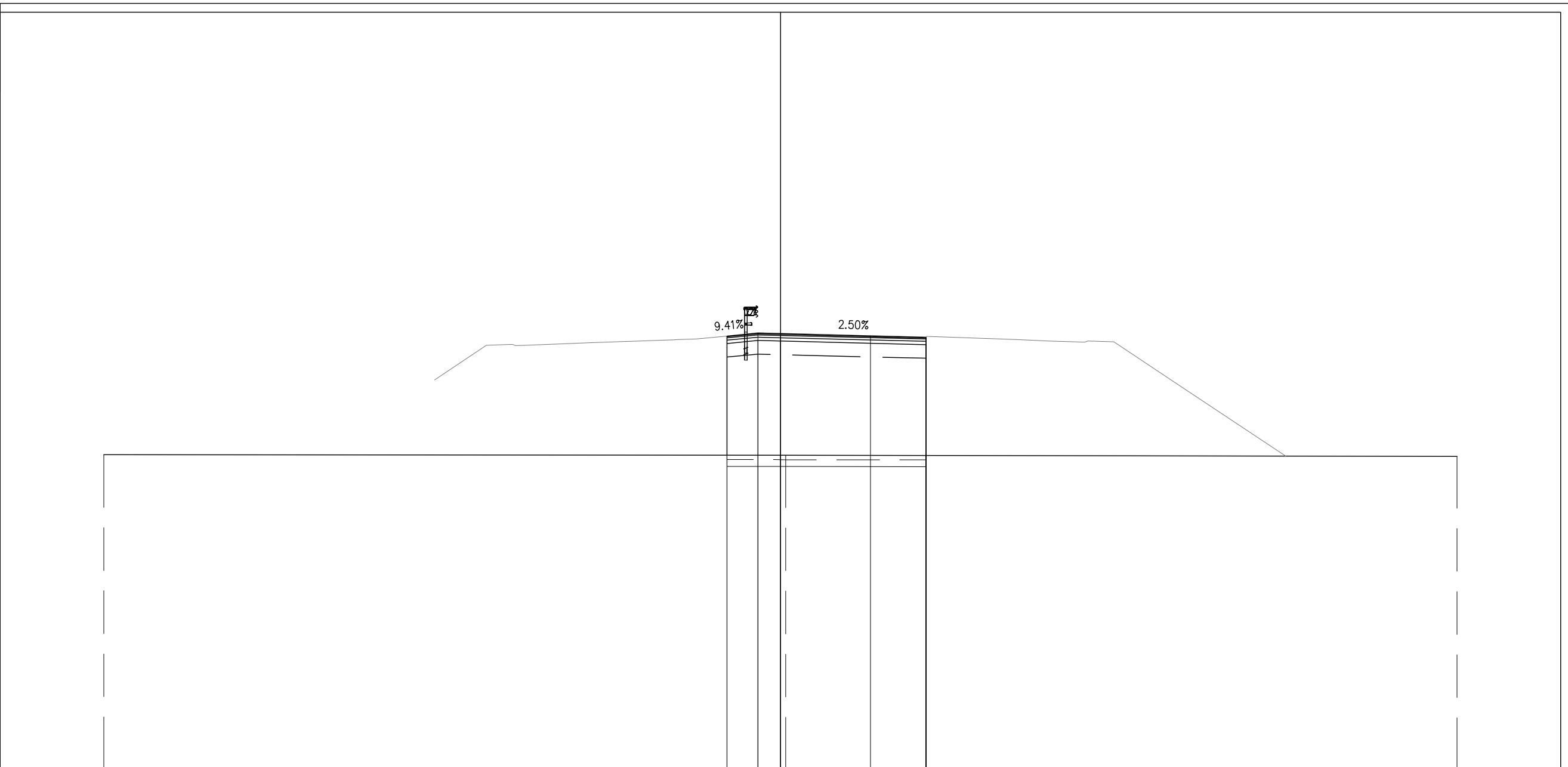

PROGRESSIVE TERRENO	-30.00		0.24						30.00
PARZIALI TERRENO		30.24						29.76	
QUOTE TERRENO	12.97		12.95						12.90
PROGRESSIVE PROGETTO			-2.37	-1.00	0.00	4.00	6.46		
PARZIALI PROGETTO			1.37	1.00	4.00	2.46			
QUOTE PROGETTO			18.24	18.37	18.34	18.24	18.18		
PROGRESSIVE RILEVATO			-2.37	-1.00	0.00	6.46	6.46		
PARZIALI RILEVATO			1.37	1.00	6.46				
QUOTE RILEVATO			17.91	18.04	18.01	17.85	17.85		

PROFILO SV-FINALE-FC
 SEZIONE FC-36
 PROGRESSIVA 575.00

BASE
 C1 0.69 mq.
 CEMENTATO
 CE1 1.08 mq.
 SOTTOFONDAZIONE STRADALE
 H1 4.22 mq.
 RILEVATO
 RI1 30.92 mq.
 TAPPETO DRENANTE
 a1 7.05 ml.
 BINDER
 b1 7.05 ml.
 BONIFICA
 bo1 7.05 ml.
 SCOTICO
 sc1 7.05 ml.

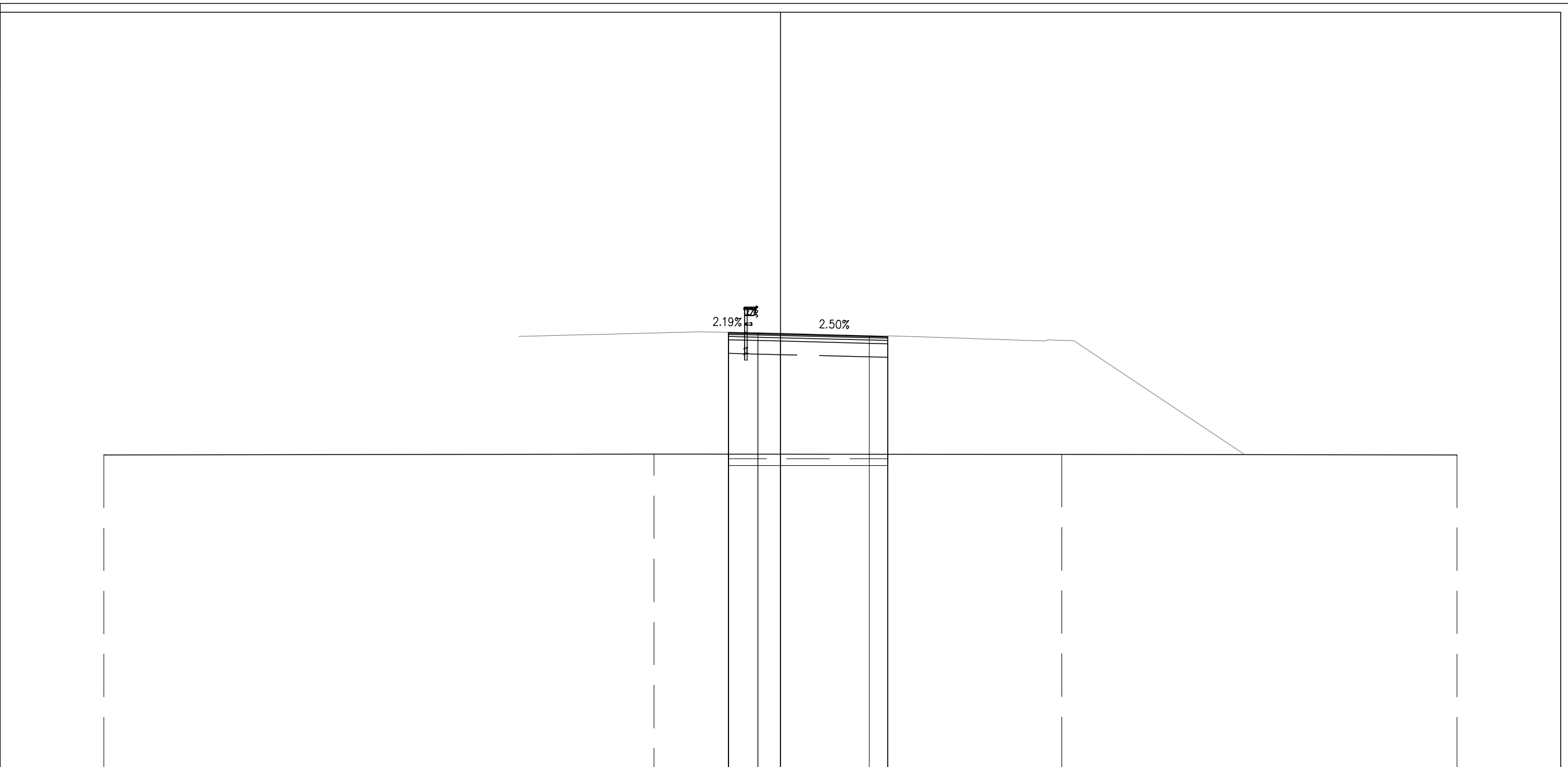

PROGRESSIVE TERRENO	-30.00	-5.61	12.47	30.00
PARZIALI TERRENO	24.39	18.08	17.53	
QUOTE TERRENO	12.96	13.00	12.99	12.96
PROGRESSIVE PROGETTO		-2.30	3.95	4.75
PARZIALI PROGETTO		1.30	3.95	0.80
QUOTE PROGETTO		18.40	18.24	18.22
PROGRESSIVE RILEVATO		-2.30	4.75	4.75
PARZIALI RILEVATO		1.30	4.75	
QUOTE RILEVATO		13.00	12.99	17.89

PROFILO SV-FINALE-FC
 SEZIONE FC-37
 PROGRESSIVA 600.00

- BASE
- C1 0.62 mq.
- CEMENTATO
- CE1 0.95 mq.
- SOTTOFONDAZIONE STRADALE
- H1 3.76 mq.
- RILEVATO
- RI1 28.16 mq.
- TAPPETO DRENANTE
- a1 6.28 ml.
- BINDER
- b1 6.28 ml.
- BONIFICA
- bo1 6.28 ml.
- SCOTICO
- sc1 6.28 ml.

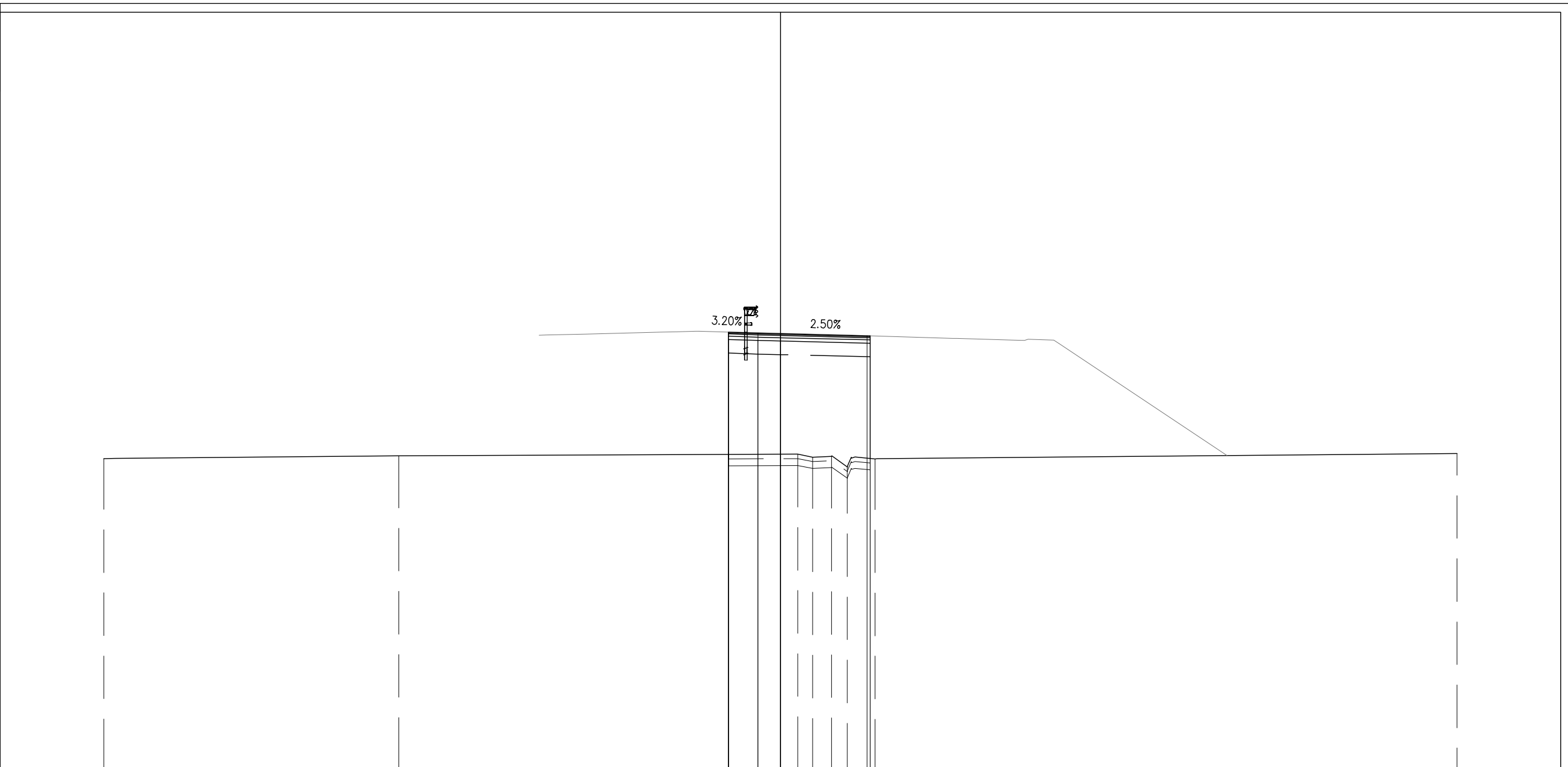

PROGRESSIVE TERRENO	-30.00	-16.92	0.76	1.43	2.27	2.97	4.20	30.00
PARZIALI TERRENO	13.08	17.68	0.67	0.84	0.70	1.23	25.80	
QUOTE TERRENO	12.80	12.93	13.00	12.86	12.91	12.43	12.78	13.03
PROGRESSIVE PROGETTO			-2.30	-1.00	0.00	3.85	3.98	
PARZIALI PROGETTO			1.30	1.00	3.85	0.13		
QUOTE PROGETTO			18.41	18.37	18.34	18.25	18.24	
PROGRESSIVE RILEVATO			-2.30	-1.00	0.00	3.98	3.98	
PARZIALI RILEVATO			1.30	1.00	3.98			
QUOTE RILEVATO			18.08	18.04	18.01	12.80	17.91	

PROFILO SV-FINALE-FC
 SEZIONE FC-38
 PROGRESSIVA 625.00

- BASE
- C1 0.61 mq.
- CEMENTATO
- CE1 0.91 mq.
- SOTTOFONDAZIONE STRADALE
- H1 3.63 mq.
- RILEVATO
- RI1 26.86 mq.
- TAPPETO DRENANTE
- a1 6.06 ml.
- BINDER
- b1 6.06 ml.
- BONIFICA
- bo1 6.06 ml.
- SCOTICO
- sc1 6.06 ml.

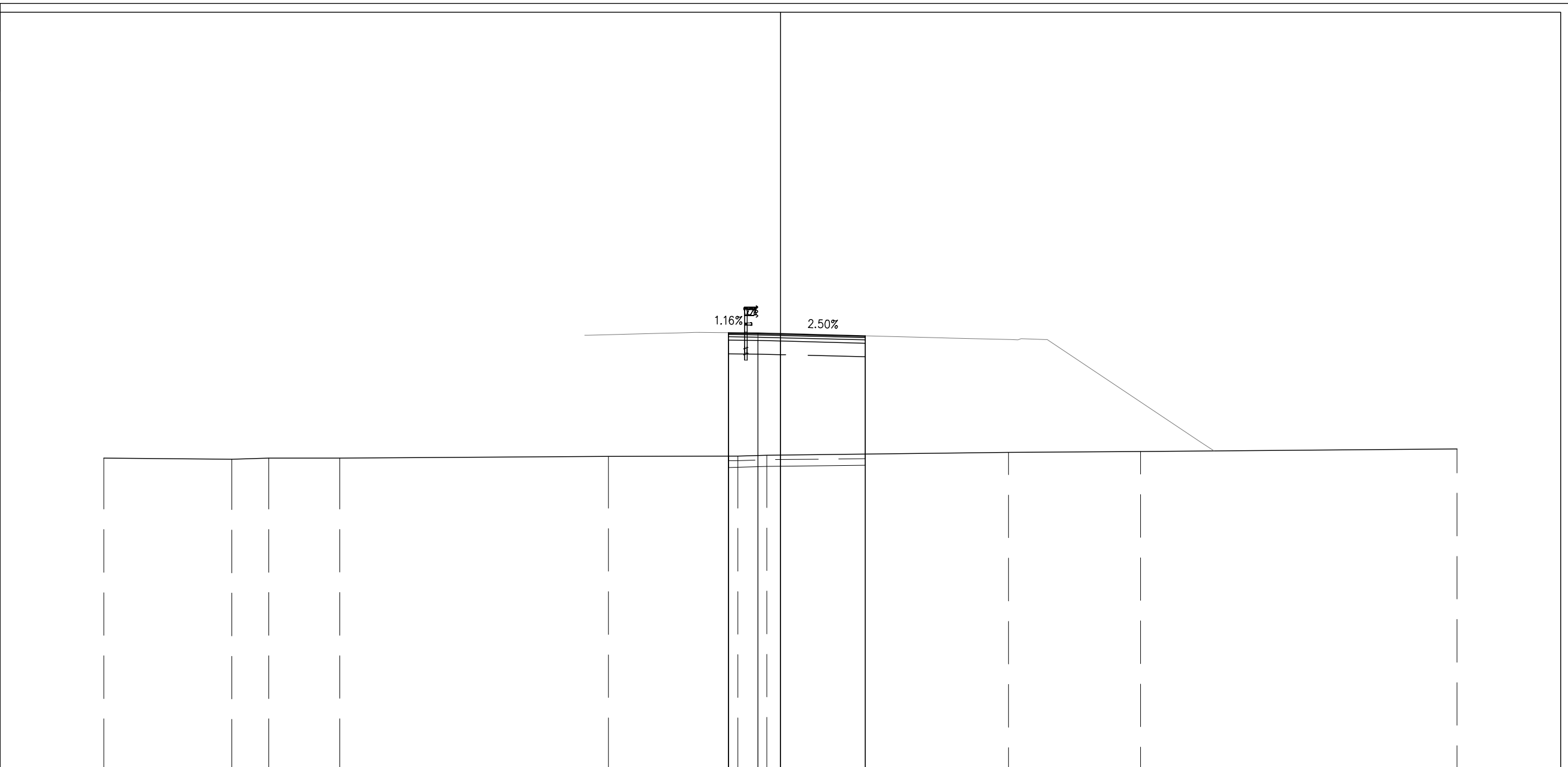

PROGRESSIVE TERRENO	-30.00	-24.33	-22.68	-19.54	-7.62	-1.89	-0.60	10.11	15.97	30.00
PARZIALI TERRENO	5.67	1.65	3.14	11.92	5.73	1.29	10.71	5.86	14.03	
QUOTE TERRENO	12.82	12.77	12.82	12.83	12.90	12.91	12.95	13.07	13.11	13.23
PROGRESSIVE PROGETTO						-2.30	-1.00	0.00	3.76	3.76
PARZIALI PROGETTO						1.30	1.00	3.76		
QUOTE PROGETTO						18.38	18.37	18.34	18.25	18.25
PROGRESSIVE RILEVATO						-2.30	-1.00	0.00	3.76	3.76
PARZIALI RILEVATO						1.30	1.00	3.76		
QUOTE RILEVATO						12.91	18.05	18.04	18.01	17.92
						18.05	18.04	18.01	13.00	13.00

PROFILO SV-FINALE-FC

SEZIONE FC-39

PROGRESSIVA 639.02

- BASE
- C1 0.60 mq.
- CEMENTATO
- CE1 0.92 mq.
- SOTTOFONDAZIONE STRADALE
- H1 3.62 mq.
- RILEVATO
- RI1 26.59 mq.
- TAPPETO DRENANTE
- a1 6.05 ml.
- BINDER
- b1 6.05 ml.
- BONIFICA
- bo1 6.05 ml.
- SCOTICO
- sc1 6.05 ml.

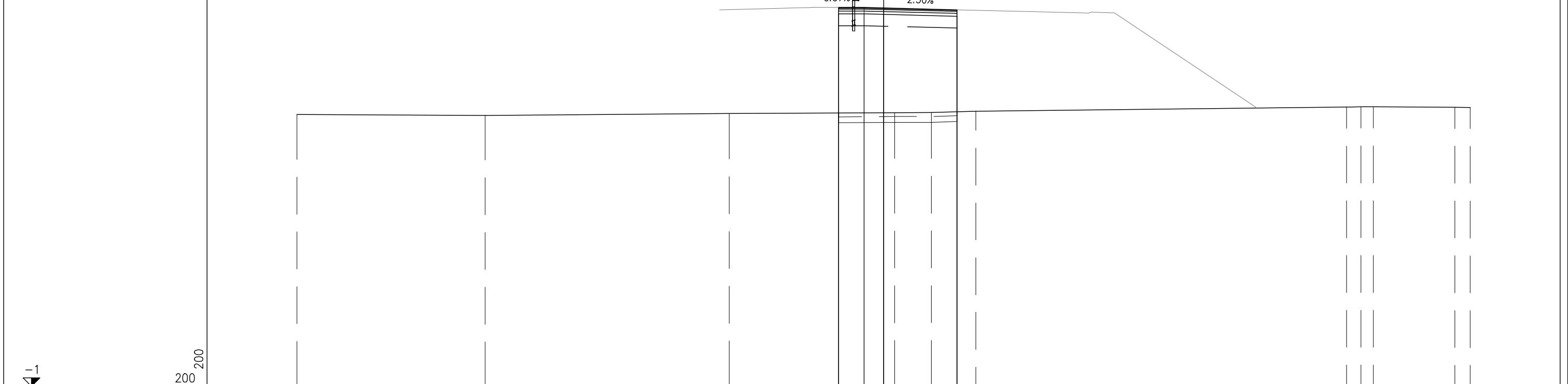

PROGRESSIVE TERRENO	-30.00	-20.38	-7.90	0.56	2.44	4.71	23.68	24.42	25.04	29.22	30.00
PARZIALI TERRENO	9.62	12.48	8.46	1.88	2.27	18.97	0.74	0.62	4.18	0.78	30.00
QUOTE TERRENO	12.90	12.84	12.94	12.99	13.00	13.07	13.28	13.29	13.29	13.26	13.26
PROGRESSIVE PROGETTO				-1.00	0.00	3.75					
PARZIALI PROGETTO				1.00	3.75						
QUOTE PROGETTO				18.37	18.34	18.25					
PROGRESSIVE RILEVATO				-2.30	-2.30	3.75	3.75	3.75			
PARZIALI RILEVATO				1.30	1.00	3.75					
QUOTE RILEVATO				18.04	18.01	17.92	13.04				

SVINCOLO DI SAN FELICE SUL PANARO - FINALE EMILIA
RAMO RC
SRA09

PROFILO SV-FINALE-RC

SEZIONE RC-1

PROGRESSIVA 0.00

- BASE
- C1 0.74 mq.
- CEMENTATO
- CE1 1.13 mq.
- VEGETALE
- D1 1.05 mq.
- SOTTOFONDAZIONE STRADALE
- H1 5.28 mq.
- RILEVATO ARGINELLO
- RA1 0.15 mq.
- RILEVATO
- RI1 10.99 mq.
- SCAVO FOSSI
- SF1 2.73 mq.
- RILEVATO FOSSI
- VF1 0.65 mq.
- TAPPETO DRENANTE
- a1 7.03 ml.
- BINDER
- b1 7.30 ml.
- BONIFICA
- bo1 10.38 ml.
- INERBIMENTO
- i3 4.08 ml.
- SCOTICO
- sc2 10.38 ml.
- SCOTICO FOSSI
- sf1 5.90 ml.

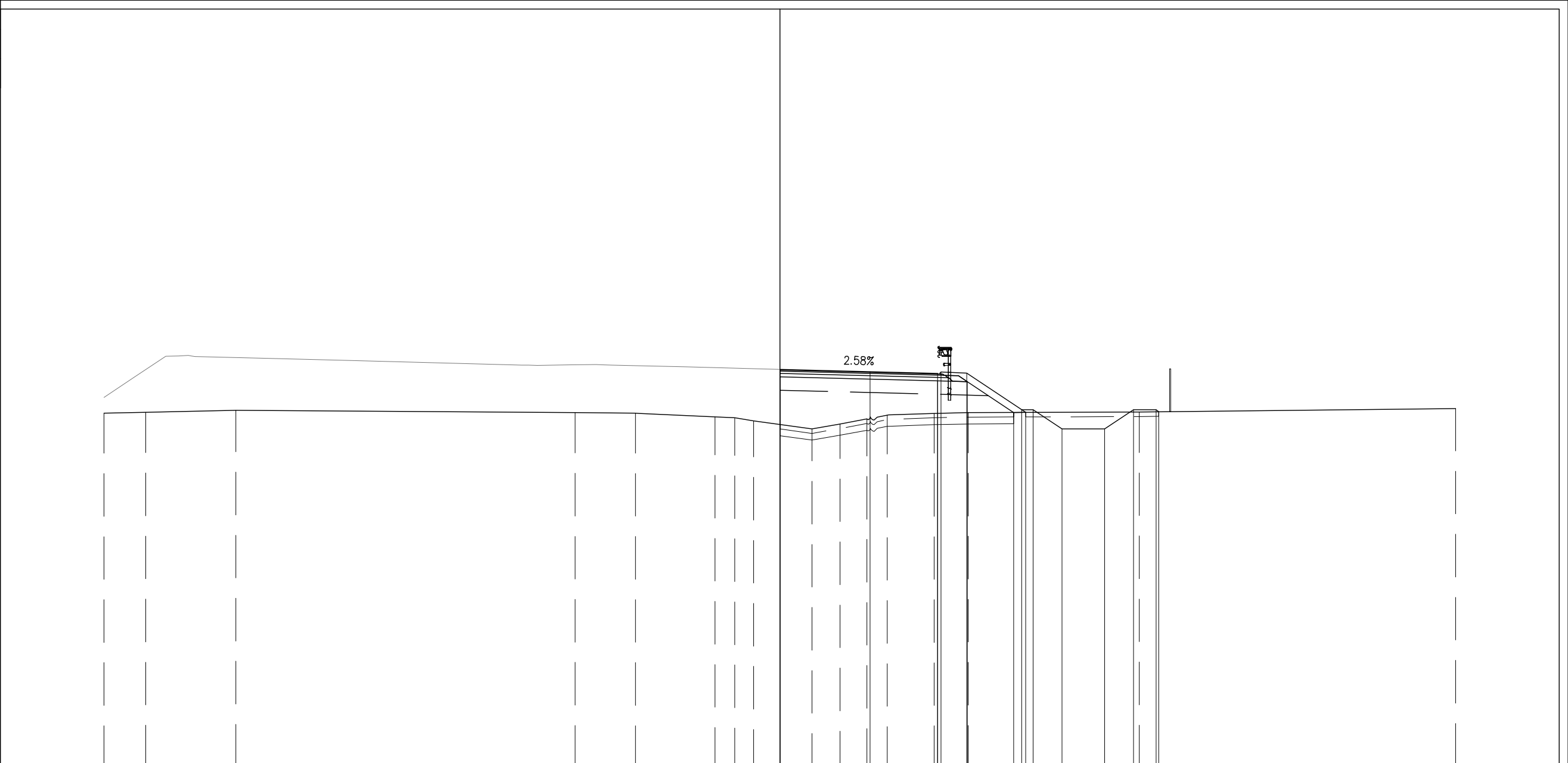

PROGRESSIVE TERRENO	-30.00	-28.16	-24.15	-9.09	-6.41	-2.88	-2.00	-1.16	1.43	2.67	3.87	4.77	6.85	8.36	15.95	30.00
PARZIALI TERRENO	1.84	4.01	15.06	2.68	3.53	0.88	0.84	2.59	1.24	1.20	0.90	2.08	1.51	7.59	14.05	
QUOTE TERRENO	12.65	12.70	12.78	12.67	12.66	12.49	12.45	12.32	11.96	12.17	12.40	12.57	12.65	12.68	12.71	12.86
PROGRESSIVE PROGETTO								0.00		4.00	4.00	7.00	7.15	8.30	10.74	11.24
PARZIALI PROGETTO								4.00	3.00	0.15	1.15	2.44	0.50	1.28	1.90	1.29
QUOTE PROGETTO							14.60	14.50	14.42	14.48	14.43	12.81	12.81	11.95	11.95	12.81
PROGRESSIVE RILEVATO							0.00	0.00		7.00	8.32	10.38	10.92			
PARZIALI RILEVATO							7.00	1.32	2.06	0.54						
QUOTE RILEVATO						14.27	12.16	14.09	14.06	12.68	12.69					

PROFILO SV-FINALE-RC
 SEZIONE RC-2
 PROGRESSIVA 25.00

- BASE
- C1 0.74 mq.
- CEMENTATO
- CE1 1.13 mq.
- VEGETALE
- D1 0.99 mq.
- SOTTOFONDAZIONE STRADALE
- H1 5.28 mq.
- RILEVATO ARGINELLO
- RA1 0.16 mq.
- RILEVATO
- RI1 9.79 mq.
- SCAVO FOSSI
- SF1 3.00 mq.
- RILEVATO FOSSI
- VF1 0.79 mq.
- TAPPETO DRENANTE
- a1 7.03 ml.
- BINDER
- b1 7.30 ml.
- BONIFICA
- bo1 10.29 ml.
- INERBIMENTO
- i3 3.84 ml.
- SCOTICO
- sc2 10.29 ml.
- SCOTICO FOSSI
- sf1 5.99 ml.

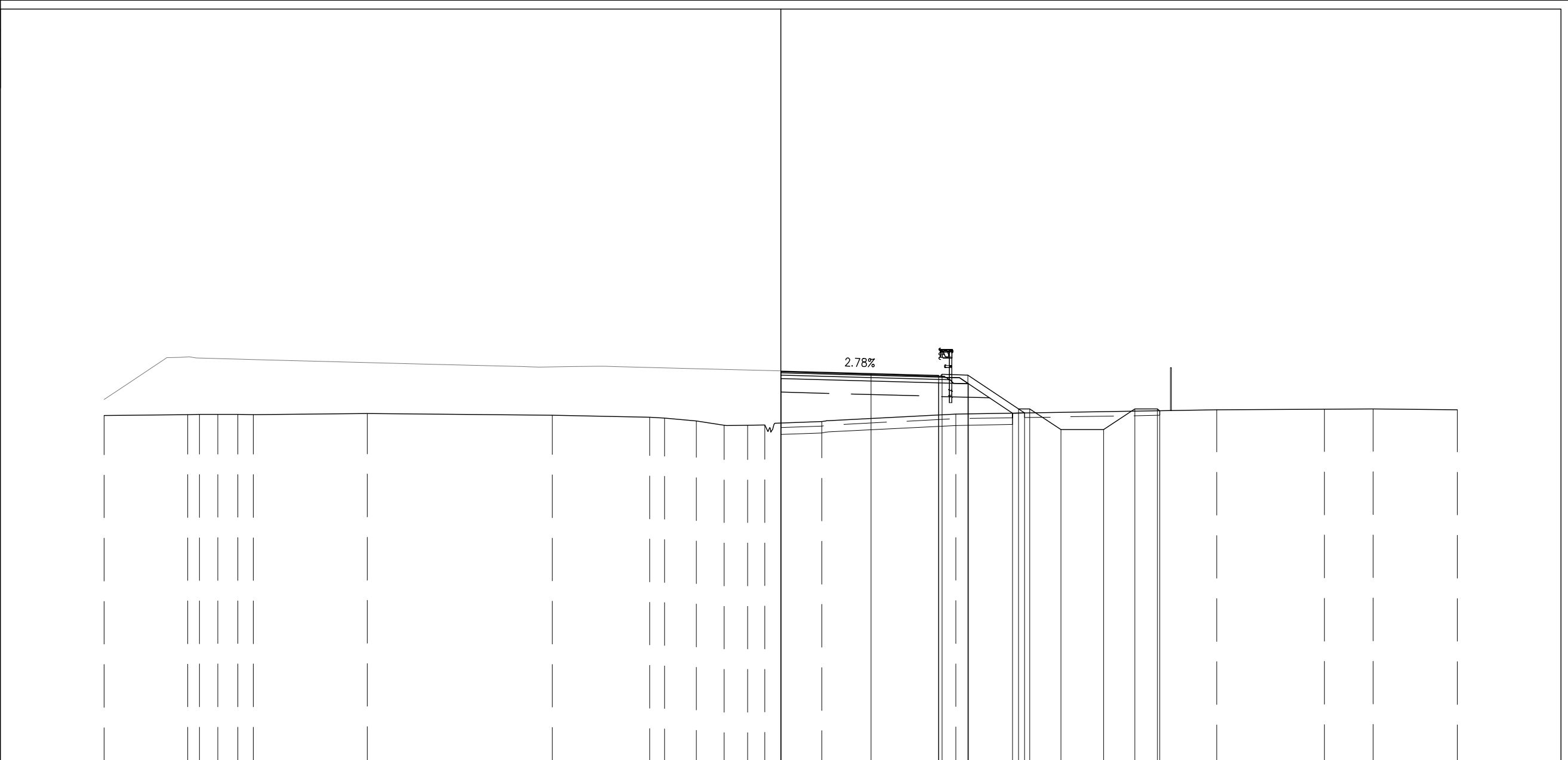

PROGRESSIVE TERRENO	-30.00	-26.30	-25.77	-24.97	-24.08	-23.39	-18.34	-10.13	-5.82	-5.15	-3.75	-2.51	-1.46	-0.71	1.83	7.77	19.33	24.10	26.27	30.00
PARZIALI TERRENO	3.70	0.53	0.80	0.89	0.69	5.05	8.21	4.31	0.67	1.40	1.24	1.05	0.75	2.54	5.94	11.56	4.77	2.17	3.73	
QUOTE TERRENO	12.58	12.62	12.62	12.63	12.63	12.62	12.66	12.59	12.50	12.46	12.34	12.15	12.15	12.16	12.31	12.64	12.83	12.85	12.88	12.83
PROGRESSIVE PROGETTO									0.00	4.00	7.00	7.15	8.30	10.54	11.04	12.42	14.32	15.70	16.70	16.80
PARZIALI PROGETTO									4.00	3.00	0.15	1.15	2.24	0.50	1.38	1.90	1.38	1.00	0.10	
QUOTE PROGETTO									14.55	14.44	14.35	14.41	14.36	12.87	12.87	11.95	11.95	12.87	12.87	12.79
PROGRESSIVE RILEVATO									0.00	0.00	7.00	8.32	10.29	10.81						
PARZIALI RILEVATO									7.00	1.32	1.97	0.52								
QUOTE RILEVATO									14.22	12.24	14.02	13.99	12.68	12.69						

PROFILO SV-FINALE-RC

SEZIONE RC-3

PROGRESSIVA 50.00

- BASE
- C1 0.74 mq.
- CEMENTATO
- CE1 1.12 mq.
- VEGETALE
- D1 0.99 mq.
- SOTTOFONDAZIONE STRADALE
- H1 5.29 mq.
- RILEVATO ARGINELLO
- RA1 0.17 mq.
- RILEVATO
- RI1 8.40 mq.
- SCAVO FOSSI
- SF1 2.79 mq.
- RILEVATO FOSSI
- VF1 0.69 mq.
- TAPPETO DRENANTE
- a1 7.03 ml.
- BINDER
- b1 7.30 ml.
- BONIFICA
- bo1 10.19 ml.
- INERBIMENTO
- i3 3.82 ml.
- SCOTICO
- sc2 10.19 ml.
- SCOTICO FOSSI
- sf1 5.91 ml.

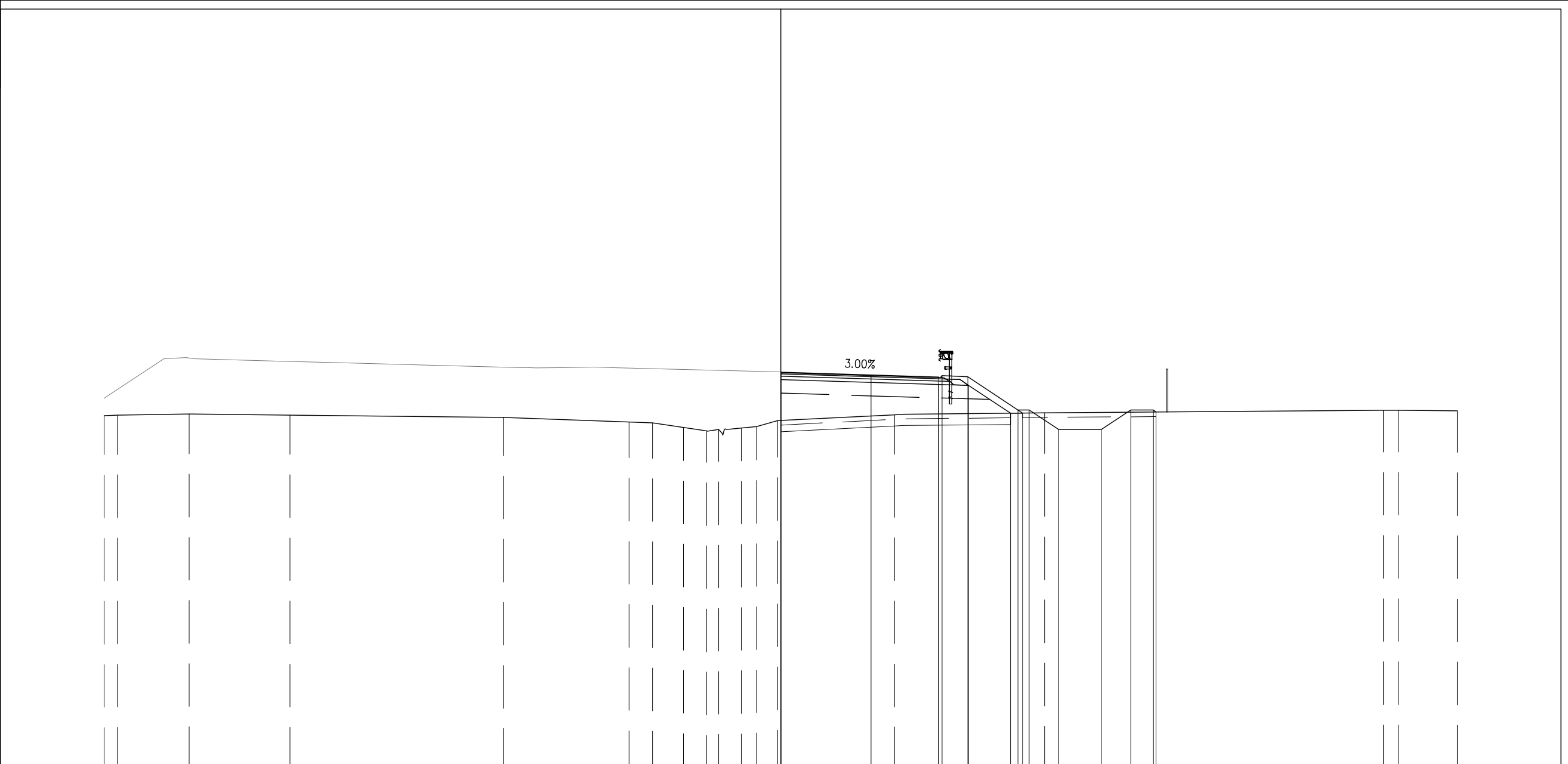

PROGRESSIVE TERRENO	-30.00	-29.42	-26.23	-21.76	-12.31	-6.72	-5.68	-4.32	-3.28	-2.75	-1.75	-1.07	-0.14	5.04	11.71	26.72	27.39	30.00						
PARZIALI TERRENO	0.58	3.19	4.47	9.45	5.59	1.04	1.36	1.04	0.53	1.00	0.68	0.93	5.18	6.67	15.01	0.67	2.61							
QUOTE TERRENO	12.57	12.59	12.64	12.59	12.48	12.29	12.25	12.04	11.89	11.96	12.02	12.09	12.34	12.61	12.69	12.81	12.81	12.78						
PROGRESSIVE PROGETTO												0.00	4.00	4.00	7.00	7.15	8.30	10.52	11.02	12.32	14.22	15.52	16.52	16.64
PARZIALI PROGETTO													4.00	3.00	0.15	1.15	2.22	0.50	1.30	1.90	1.30	1.00	1.00	0.12
QUOTE PROGETTO												14.50	14.38	14.29	14.34	14.30	12.82	12.82	11.95	11.95	12.82	12.82	12.73	12.73
PROGRESSIVE RILEVATO												0.00	0.00	7.00	8.33	10.19	10.73	12.67	12.68	13.92	13.92	12.67	12.68	
PARZIALI RILEVATO													7.00	1.33	1.86	0.54								
QUOTE RILEVATO												14.17	12.35	13.96	13.92	12.67	12.68							

PROFILO SV-FINALE-RC
 SEZIONE RC-4
 PROGRESSIVA 75.00

- BASE
- C1 0.75 mq.
- CEMENTATO
- CE1 1.14 mq.
- VEGETALE
- D1 0.91 mq.
- SOTTOFONDAZIONE STRADALE
- H1 5.28 mq.
- RILEVATO ARGINELLO
- RA1 0.15 mq.
- RILEVATO
- RI1 7.04 mq.
- SCAVO FOSSI
- SF1 2.79 mq.
- RILEVATO FOSSI
- VF1 0.63 mq.
- TAPPETO DRENANTE
- a1 7.03 ml.
- BINDER
- b1 7.30 ml.
- BONIFICA
- bo1 10.05 ml.
- INERBIMENTO
- i3 3.67 ml.
- SCOTICO
- sc2 10.05 ml.
- SCOTICO FOSSI
- sf1 5.96 ml.

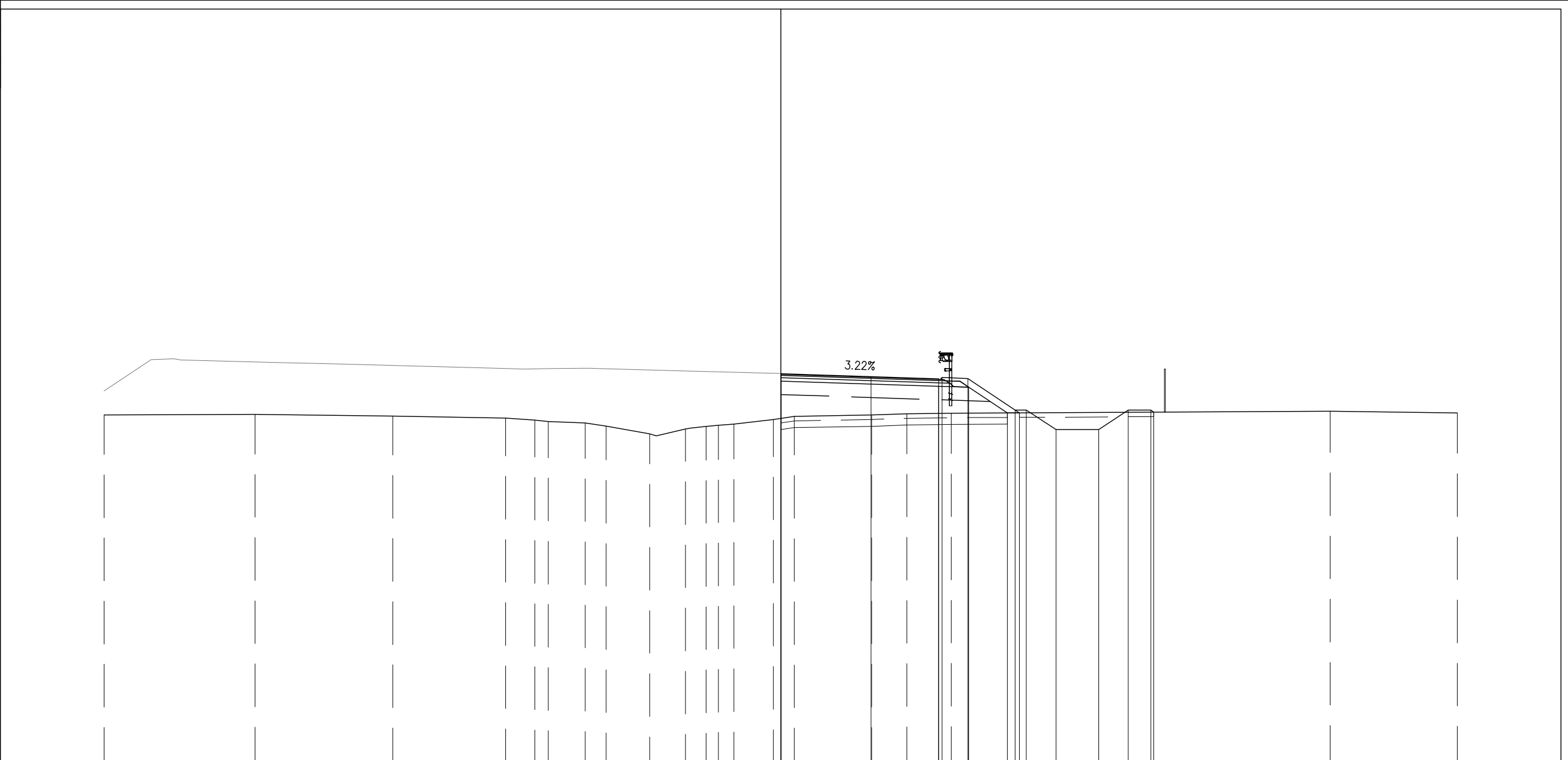

PROGRESSIVE TERRENO	-30.00	-23.32	-17.20	-12.20	-10.91	-10.31	-8.66	-7.74	-5.81	-4.23	-3.31	-2.77	-2.08	-0.33	0.61	4.03	5.59	7.56	24.37	30.00							
PARZIALI TERRENO	6.68	6.12	5.00	1.29	0.60	1.65	0.92	1.93	1.58	0.92	0.54	0.69	1.75	0.94	3.42	1.56	1.97	16.81	5.63								
QUOTE TERRENO	12.60	12.63	12.55	12.47	12.38	12.31	12.25	12.11	11.77	11.98	12.10	12.15	12.20	12.40	12.54	12.60	12.66	12.68	12.77	12.70							
PROGRESSIVE PROGETTO														0.00	4.00	4.00	7.00	7.15	8.30	10.39	10.89	12.20	14.10	15.41	16.41	16.54	
PARZIALI PROGETTO														4.00	3.00	0.15	1.15	2.09	0.50	1.31	1.90	1.31	1.00	1.00	0.15		
QUOTE PROGETTO														14.43	14.31	14.21	14.27	14.22	12.82	12.82	11.95	11.95	12.82	12.82	12.73	12.73	
PROGRESSIVE RILEVATO														0.00	0.00		7.00	8.33	10.05	10.58							
PARZIALI RILEVATO														7.00	1.33	1.72	0.50										
QUOTE RILEVATO														14.10	12.45		13.88	13.84	12.69	12.70							

PROFILO SV-FINALE-RC
 SEZIONE RC-5
 PROGRESSIVA 100.00

- BASE
- C1 0.74 mq.
- CEMENTATO
- CE1 1.12 mq.
- VEGETALE
- D1 0.89 mq.
- SOTTOFONDAZIONE STRADALE
- H1 5.29 mq.
- RILEVATO ARGINELLO
- RA1 0.17 mq.
- RILEVATO
- RI1 6.28 mq.
- SCAVO FOSSI
- SF1 2.61 mq.
- RILEVATO FOSSI
- VF1 0.71 mq.
- TAPPETO DRENANTE
- a1 7.03 ml.
- BINDER
- b1 7.30 ml.
- BONIFICA
- bo1 9.96 ml.
- INERBIMENTO
- i3 3.53 ml.
- SCOTICO
- sc2 9.96 ml.
- SCOTICO FOSSI
- sf1 5.79 ml.

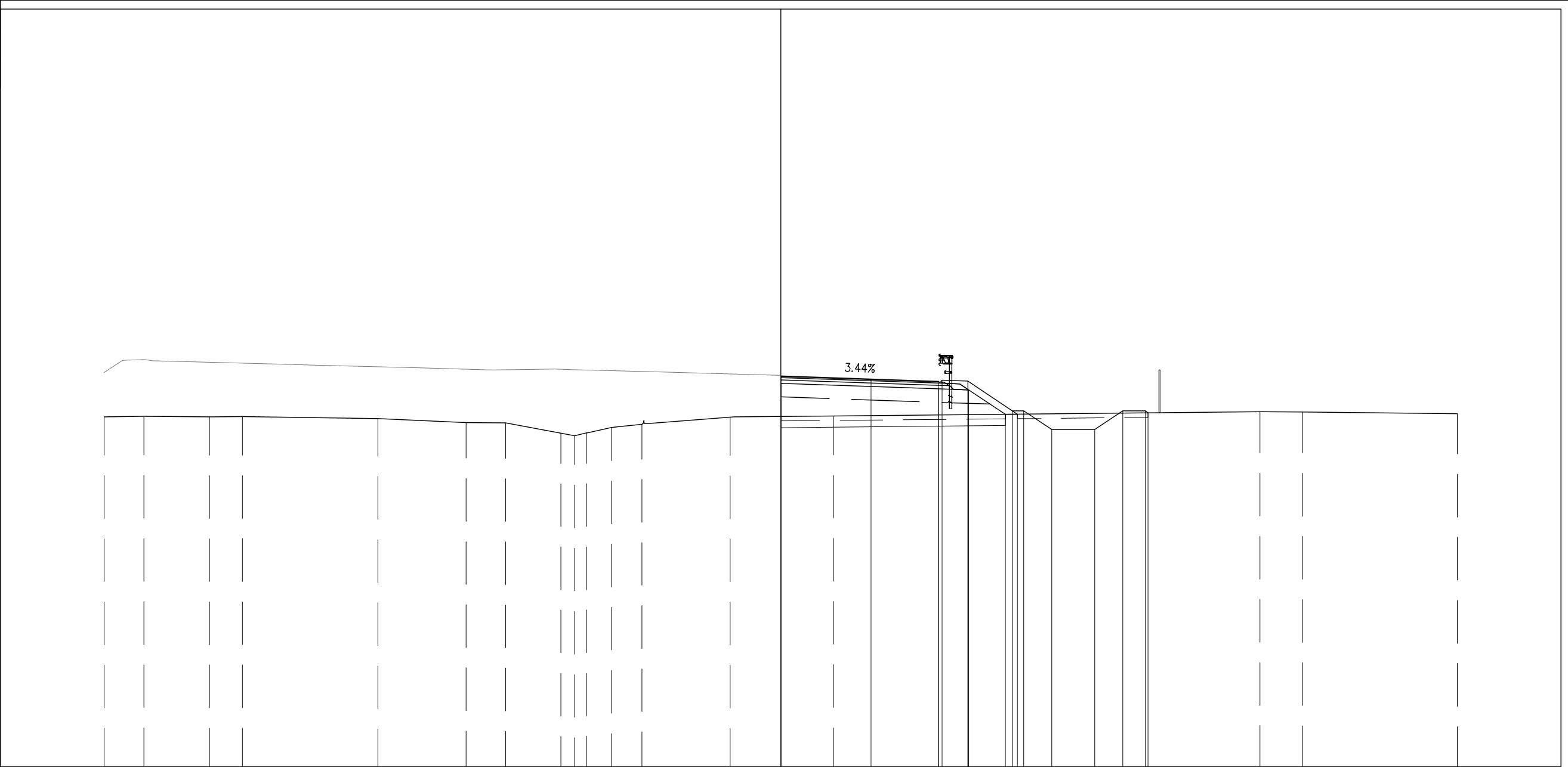

PROGRESSIVE TERRENO	-30.00	-28.25	-25.33	-23.88	-17.86	-13.95	-12.20	-9.75	-9.13	-8.62	-7.50	-6.15	-2.24	2.34	21.26	23.15	30.00
PARZIALI TERRENO	1.75	2.92	1.45	6.02	3.91	1.75	2.45	0.62	0.51	1.12	1.35	3.91	4.58	18.92	1.89	6.85	
QUOTE TERRENO	12.52	12.54	12.52	12.53	12.44	12.27	12.25	11.79	11.68	11.80	12.04	12.18	12.50	12.56	12.74	12.73	12.65
PROGRESSIVE PROGETTO													0.00	4.00	7.00	7.15	8.30
PARZIALI PROGETTO													4.00	3.00	0.15	1.15	1.98
QUOTE PROGETTO													14.00	14.19	14.09	14.15	14.10
PROGRESSIVE RILEVATO													0.00	0.00	7.00	8.34	9.96
PARZIALI RILEVATO													7.00	1.34	1.62	0.54	0.50
QUOTE RILEVATO													12.63	12.63	12.63	12.63	12.63

PROFILO SV-FINALE-RC
 SEZIONE RC-6
 PROGRESSIVA 132.88

- BASE
- C1 0.74 mq.
- CEMENTATO
- CE1 1.14 mq.
- VEGETALE
- D1 0.79 mq.
- SOTTOFONDAZIONE STRADALE
- H1 5.29 mq.
- RILEVATO ARGINELLO
- RA1 0.15 mq.
- RILEVATO
- RI1 4.48 mq.
- SCAVO FOSSI
- SF1 2.65 mq.
- RILEVATO FOSSI
- VF1 0.68 mq.
- TAPPETO DRENANTE
- a1 7.03 ml.
- BINDER
- b1 7.30 ml.
- BONIFICA
- bo1 9.70 ml.
- INERBIMENTO
- i3 3.25 ml.
- SCOTICO
- sc2 9.70 ml.
- SCOTICO FOSSI
- sf1 5.85 ml.

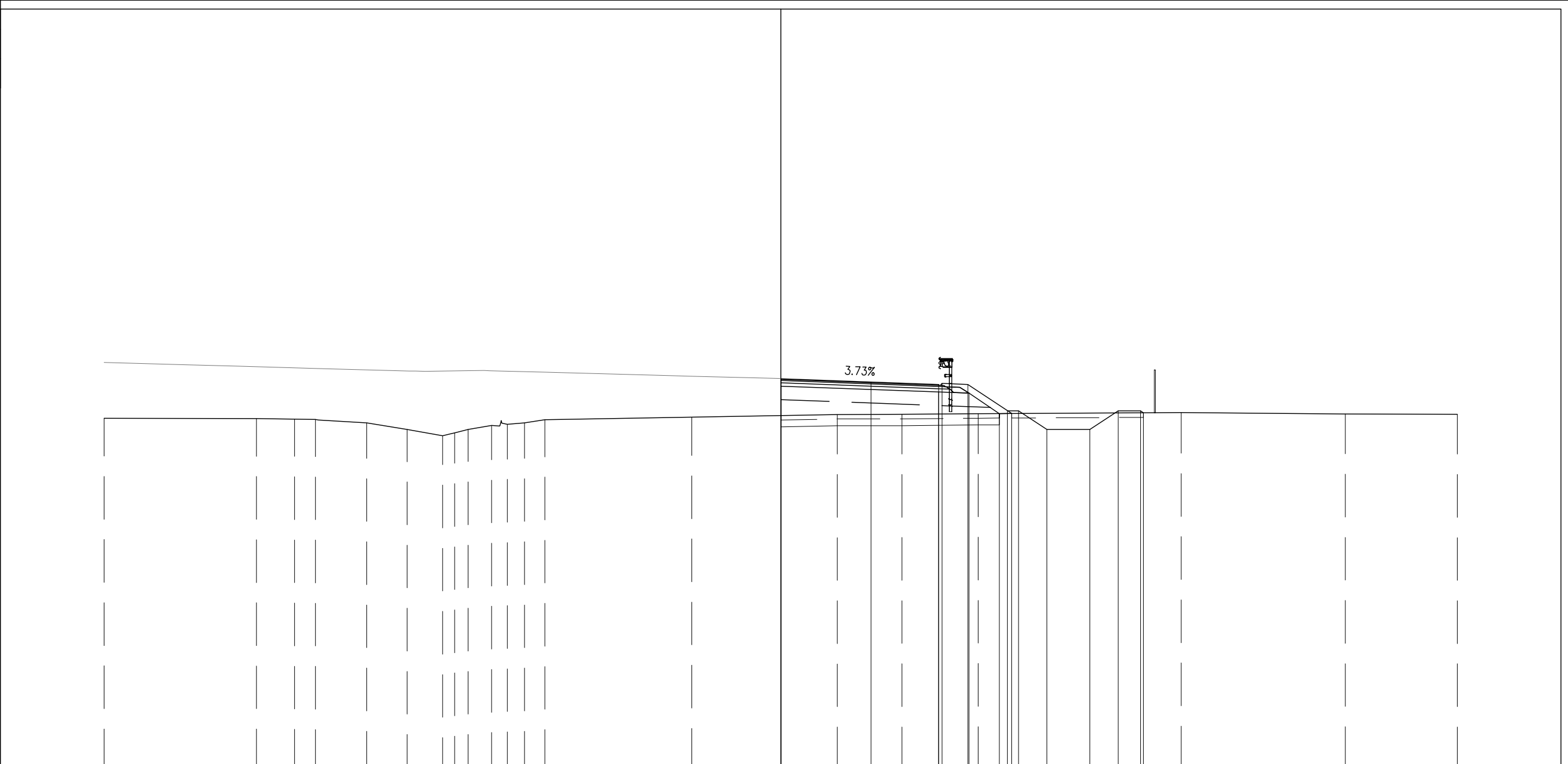

PROGRESSIVE TERRENO	-30.00	-23.25	-21.57	-20.63	-18.36	-16.56	-15.00	-14.46	-13.87	-12.82	-12.12	-11.36	-10.46	-3.95	2.51	5.37	8.75	17.76	25.04	30.00						
PARZIALI TERRENO	6.75	1.68	0.94	2.27	1.80	1.56	0.54	0.59	1.05	0.70	0.76	0.90	6.51	6.46	2.86	3.38	9.01	7.28	4.96							
QUOTE TERRENO	12.45	12.44	12.41	12.40	12.25	11.95	11.68	11.81	11.96	12.13	12.18	12.25	12.39	12.50	12.62	12.63	12.66	12.70	12.65	12.62						
PROGRESSIVE PROGETTO														0.00	4.00	4.00	7.00	7.15	8.30	10.05	10.55	11.81	13.71	14.96	15.96	16.09
PARZIALI PROGETTO														4.00	3.00	0.15	1.15	1.75	0.50	1.26	1.90	1.25	1.25	1.00	1.00	0.15
QUOTE PROGETTO														14.21	14.06	13.94	14.00	13.95	12.79	12.79	11.95	11.95	12.79	12.79	12.69	12.69
PROGRESSIVE RILEVATO														0.00	0.00	7.00	8.34	9.70	10.24	11.81	13.71	14.96	15.96	16.09		
PARZIALI RILEVATO														7.00	1.34	1.36	0.54	1.26	1.90	1.25	1.25	1.00	1.00	0.15		
QUOTE RILEVATO														13.88	12.57	13.61	13.56	12.66	12.66	11.95	11.95	12.79	12.79	12.69	12.69	

PROFILO SV-FINALE-RC
 SEZIONE RC-7
 PROGRESSIVA 150.00

- BASE
- C1 0.75 mq.
- CEMENTATO
- CE1 1.13 mq.
- VEGETALE
- D1 0.94 mq.
- SOTTOFONDAZIONE STRADALE
- H1 5.30 mq.
- RILEVATO ARGINELLO
- RA1 0.16 mq.
- RILEVATO
- RI1 7.10 mq.
- SCAVO FOSSI
- SF1 2.06 mq.
- RILEVATO FOSSI
- VF1 0.85 mq.
- TAPPETO DRENANTE
- a1 7.03 ml.
- BINDER
- b1 7.30 ml.
- BONIFICA
- bo1 10.08 ml.
- INERBIMENTO
- i3 3.63 ml.
- SCOTICO
- sc2 10.08 ml.
- SCOTICO FOSSI
- sf1 5.47 ml.

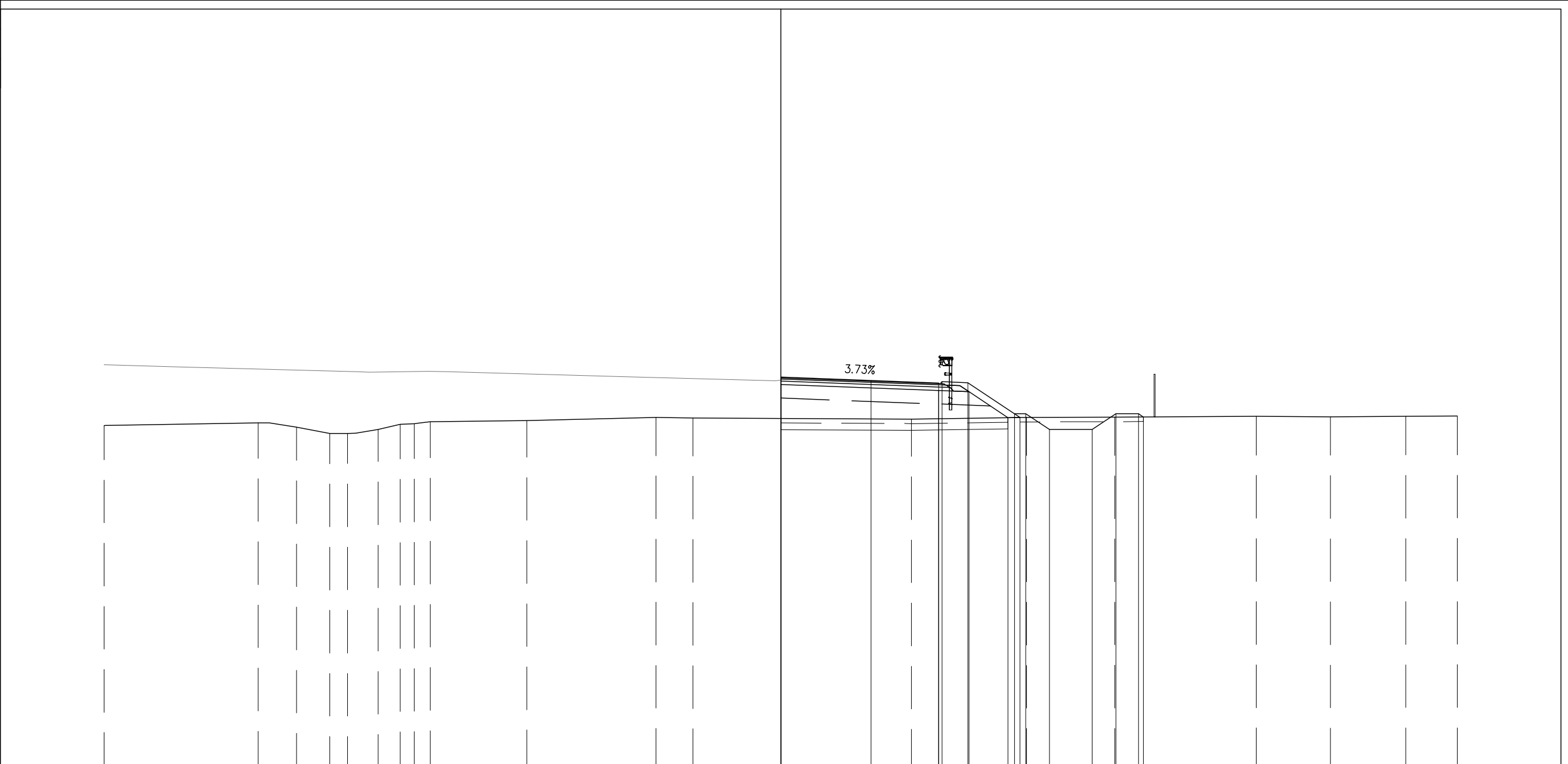

PROGRESSIVE TERRENO	-30.00	-23.17	-21.47	-20.00	-19.21	-17.85	-16.87	-16.25	-15.54	-11.26	-5.54	-3.90	5.79	10.90	14.81	21.08	24.38	27.71	30.00
PARZIALI TERRENO	6.83	1.70	1.47	0.79	1.36	0.98	0.62	0.71	4.28	5.72	1.64	9.69	5.11	3.91	6.27	3.30	3.33	2.29	
QUOTE TERRENO	12.13	12.25	12.06	11.77	11.78	11.96	12.19	12.22	12.30	12.36	12.49	12.46	12.42	12.49	12.50	12.54	12.52	12.54	12.56
PROGRESSIVE PROGETTO										0.00	4.00	4.00	7.00	7.15	8.30	10.36	10.86	11.91	13.81
PARZIALI PROGETTO										4.00	3.00	0.15	1.15	2.06	0.50	1.05	1.90	1.05	1.05
QUOTE PROGETTO										14.28	14.13	14.02	14.07	14.03	12.65	12.65	11.95	11.95	12.65
PROGRESSIVE RILEVATO										0.00	0.00	7.00	8.34	10.08	10.61	11.95	13.81	14.86	15.86
PARZIALI RILEVATO										7.00	1.34	1.74	0.50	1.05	1.90	1.05	1.05	0.22	0.22
QUOTE RILEVATO										13.95	12.44	14.28	14.13	14.02	14.07	14.03	12.65	12.65	11.95

PROFILO SV-FINALE-RC
 SEZIONE RC-8
 PROGRESSIVA 175.00

- BASE
- C1 0.88 mq.
- CEMENTATO
- CE1 1.38 mq.
- VEGETALE
- D1 0.55 mq.
- D2 1.29 mq.
- Totale: 1.84 mq.
- SOTTOFONDAZIONE STRADALE
- H1 6.87 mq.
- RILEVATO ARGINELLO
- RA1 0.12 mq.
- RA2 0.15 mq.
- Totale: 0.27 mq.
- RILEVATO
- RI1 18.74 mq.
- SCAVO FOSSI
- SF1 2.05 mq.
- RILEVATO FOSSI
- VF1 2.71 mq.
- TAPPETO DRENANTE
- a1 8.06 ml.
- BINDER
- b1 8.60 ml.
- BONIFICA
- bo1 14.36 ml.
- INERBIMENTO
- i3 2.40 ml.
- i4 4.29 ml.
- Totale: 6.69 ml.
- SCOTICO
- sc2 14.36 ml.
- SCOTICO FOSSI
- sf1 5.65 ml.

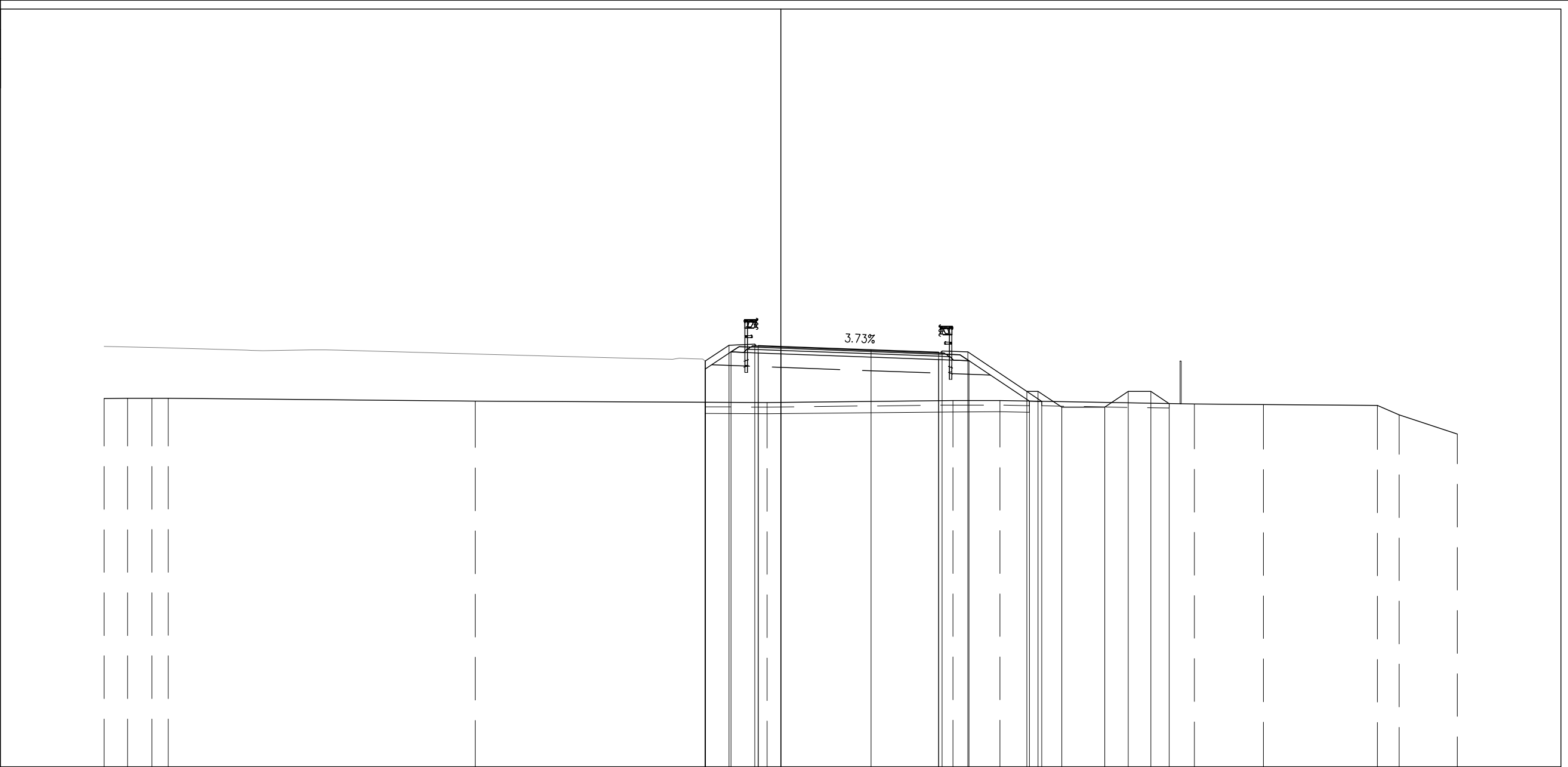

PROGRESSIVE TERRENO	-30.00	-28.97	-27.89	-27.16		-13.55		-0.60		7.64	9.72			18.35	21.40		26.47	27.42	30.00	
PARZIALI TERRENO	1.03	1.08	0.73		13.61		12.95		8.24	2.08		8.63	3.05	5.07	0.95	2.58				
QUOTE TERRENO	12.33	12.33	12.34	12.34		12.21		12.15		12.24	12.24			12.08	12.06		12.03	11.60	10.75	
PROGRESSIVE PROGETTO																				
PARZIALI PROGETTO									4.00	3.00	7.00	7.15	8.30	2.61	0.50	1.05	1.90	1.05	1.00	0.82
QUOTE PROGETTO									14.49	14.38	14.44	14.39	12.65	12.65	11.95	11.95	12.65	12.65	12.10	
PROGRESSIVE RILEVATO																				
PARZIALI RILEVATO									7.00	1.34	2.68									
QUOTE RILEVATO	12.16	13.63	14.40	14.35	14.31				14.05	14.00	12.22	12.21								

PROFILO SV-FINALE-RC

SEZIONE RC-9

PROGRESSIVA 200.00

BASE	
C1	0.88 mq.
CEMENTATO	
CE1	1.38 mq.
VEGETALE	
D1	1.42 mq.
D2	1.58 mq.
Totale:	3.00 mq.
SOTTOFONDAZIONE STRADALE	
H1	6.86 mq.
RILEVATO ARGINELLO	
RA1	0.13 mq.
RA2	0.16 mq.
Totale:	0.29 mq.
RILEVATO	
RI1	25.53 mq.
SCAVO FOSSI	
SF1	2.07 mq.
SF2	2.06 mq.
Totale:	4.13 mq.
RILEVATO FOSSI	
VF1	1.17 mq.
VF2	1.60 mq.
Totale:	2.77 mq.
TAPPETO DRENANTE	
a1	8.06 ml.
BINDER	
b1	8.60 ml.
BONIFICA	
bo1	17.48 ml.
INERBIMENTO	
i5	5.18 ml.
i6	5.72 ml.
Totale:	10.90 ml.
SCOTICO	
sc4	17.48 ml.
SCOTICO FOSSI	
sf1	4.01 ml.
sf2	5.53 ml.
sf3	0.00 ml.
Totale:	9.54 ml.

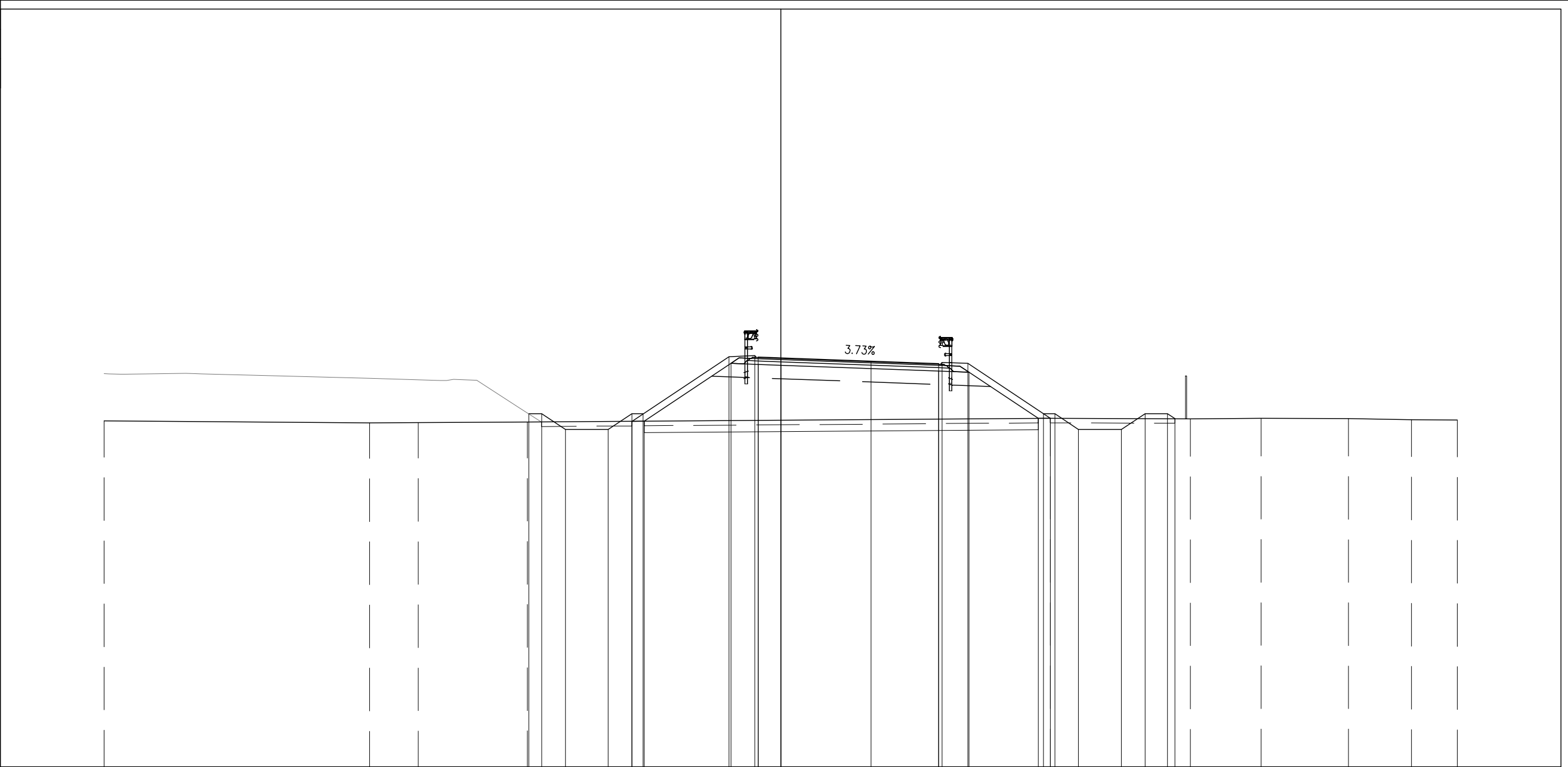

PROGRESSIVE TERRENO	-30.00	-18.23	-16.07	-11.24						11.95	18.17	21.30	25.18	27.97	30.00											
PARZIALI TERRENO		11.77	2.16	4.83		23.19		6.22	3.13	3.88	2.79	2.03														
QUOTE TERRENO	12.34	12.24	12.26	12.28						12.45	12.43	12.46	12.44	12.39	12.37											
PROGRESSIVE PROGETTO				-11.18	-10.60	-9.55	-7.65	-6.60	-6.10	-2.30	-1.15	-1.00	0.00	4.00	4.00	7.00	7.15	8.30	11.65	12.15	13.20	15.10	16.15	17.15	17.48	
PARZIALI PROGETTO				0.58	1.05	1.90	1.05	0.50	3.80	1.15	0.15	1.00	4.00	3.00	0.15	1.15	3.35	0.50	1.05	1.90	1.05	1.00	1.00	0.36		
QUOTE PROGETTO				12.65	12.65	11.95	11.95	12.65	12.65	15.18	15.23	15.17	15.14	14.99	14.88	14.93	14.89	12.65	12.65	11.95	11.95	12.65	12.65	12.43		
PROGRESSIVE RILEVATO								-6.60	-6.06	-2.20	-1.00	0.00						11.42	11.95							
PARZIALI RILEVATO								0.54	3.86	1.20	1.00	7.00	1.34	3.08	0.53			0.53								
QUOTE RILEVATO								12.31	12.32	14.89	14.84	14.81			14.55	14.50		12.45	12.45							

PROFILO SV-FINALE-RC

SEZIONE RC-13

PROGRESSIVA 300.00

BASE	
C1	0.87 mq.
CEMENTATO	
CE1	1.37 mq.
VEGETALE	
D1	2.46 mq.
D2	2.38 mq.
Totale:	4.84 mq.
SOTTOFONDAZIONE STRADALE	
H1	6.87 mq.
RILEVATO ARGINELLO	
RA1	0.14 mq.
RA2	0.15 mq.
Totale:	0.29 mq.
RILEVATO	
RI1	61.55 mq.
SCAFO FOSSI	
SF1	2.06 mq.
RILEVATO FOSSI	
VF1	1.32 mq.
TAPPETO DRENANTE	
a1	8.06 ml.
BINDER	
b1	8.60 ml.
BONIFICA	
bo1	22.46 ml.
INERBIMENTO	
i3	9.18 ml.
i4	8.17 ml.
Totale:	17.35 ml.
SCOTICO	
sc2	22.46 ml.
SCOTICO FOSSI	
sf1	5.41 ml.

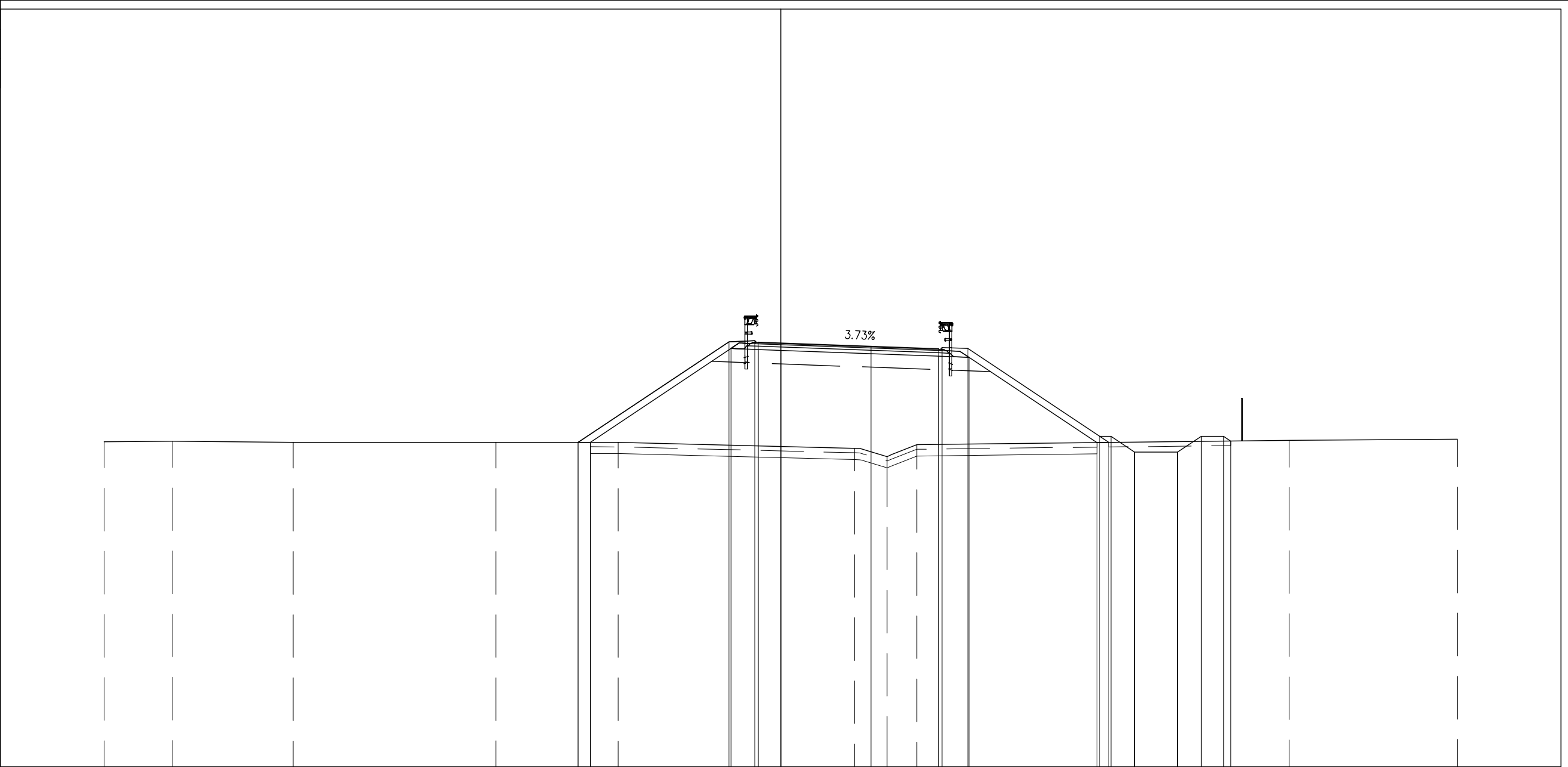

PROGRESSIVE TERRENO	-30.00	-26.98	-21.62	-12.63	-7.21		3.28	4.72	6.03			22.55	30.00
PARZIALI TERRENO		3.02	5.36	8.99	5.42	10.49	1.44	1.31		16.52		7.45	
QUOTE TERRENO	12.41	12.43	12.39	12.39	12.39		12.12	11.75	12.28			12.47	12.52
PROGRESSIVE PROGETTO						-8.98							
PARZIALI PROGETTO					6.68	1.15	4.00	3.00		5.84			
QUOTE PROGETTO						16.84	16.65	16.54	16.55				
PROGRESSIVE RILEVATO						-8.98							
PARZIALI RILEVATO					6.24	1.20	7.00	1.34		5.68			
QUOTE RILEVATO						16.55	16.21	16.16					

PROFILO SV-FINALE-RC
SEZIONE RC-14
PROGRESSIVA 325.00

BASE
C1 0.87 mq.
CEMENTATO
CE1 1.38 mq.
VEGETALE
D1 0.15 mq.
D2 2.48 mq.
Totale: 2.63 mq.
SOTTOFONDAZIONE STRADALE
H1 6.87 mq.
RILEVATO ARGINELLO
RA1 0.12 mq.
RA2 0.16 mq.
Totale: 0.28 mq.
RILEVATO
RI1 55.72 mq.
RIEMPIMENTO
RP1 0.98 mq.
SCAVO FOSSI
SF1 2.05 mq.
RILEVATO FOSSI
VF1 0.91 mq.
TAPPETO DRENANTE
a1 8.06 ml.
BINDER
b1 8.60 ml.
BONIFICA
bo1 17.90 ml.
INERBIMENTO
i3 2.40 ml.
i4 8.74 ml.
Totale: 11.14 ml.
SCOTICO
sc2 17.90 ml.
SCOTICO FOSSI
sf1 5.45 ml.

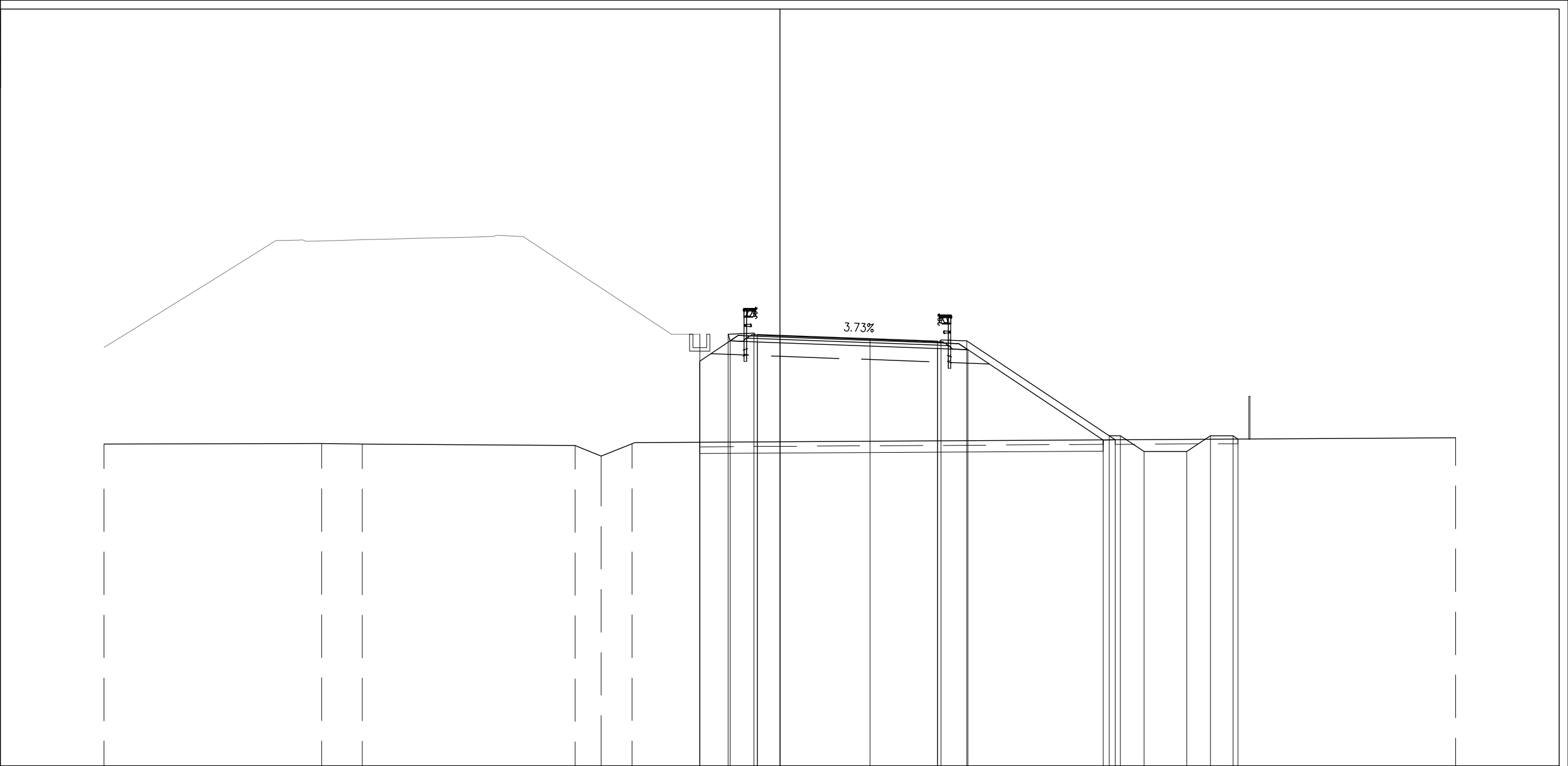

PROGRESSIVE TERRENO	-30.00	-20.34	-18.53	-9.09	-7.93	-6.56															30.00
PARZIALI TERRENO		9.66	1.81	9.44	1.16	1.37				36.56											
QUOTE TERRENO	12.29	12.30	12.28	12.22	11.75	12.30															12.56
PROGRESSIVE PROGETTO																					
PARZIALI PROGETTO																					
QUOTE PROGETTO																					
PROGRESSIVE RILEVATO																					
PARZIALI RILEVATO																					
QUOTE RILEVATO																					

-2
200
200

PROFILO SV-FINALE-RC
 SEZIONE RC-17
 PROGRESSIVA 400.00

BASE
 C1 0.89 mq.
 CEMENTATO
 CE1 1.38 mq.
 VEGETALE
 D1 0.15 mq.
 D2 2.66 mq.
 Totale: 2.81 mq.
 SOTTOFONDAZIONE STRADALE
 H1 6.85 mq.
 RILEVATO ARGINELLO
 RA1 0.13 mq.
 RA2 0.16 mq.
 Totale: 0.29 mq.
 RILEVATO
 RI1 64.74 mq.
 RIEMPIMENTO
 RP1 2.69 mq.
 SCAVO FOSSI
 SF1 3.37 mq.
 RILEVATO FOSSI
 VF1 0.62 mq.
 TAPPETO DRENANTE
 a1 8.06 ml.
 BINDER
 b1 8.60 ml.
 BONIFICA
 bo1 19.51 ml.
 INERBIMENTO
 i3 9.51 ml.
 i4 3.50 ml.
 Totale: 13.01 ml.
 SCOTICO
 sc2 19.51 ml.
 SCOTICO FOSSI
 sf1 6.36 ml.

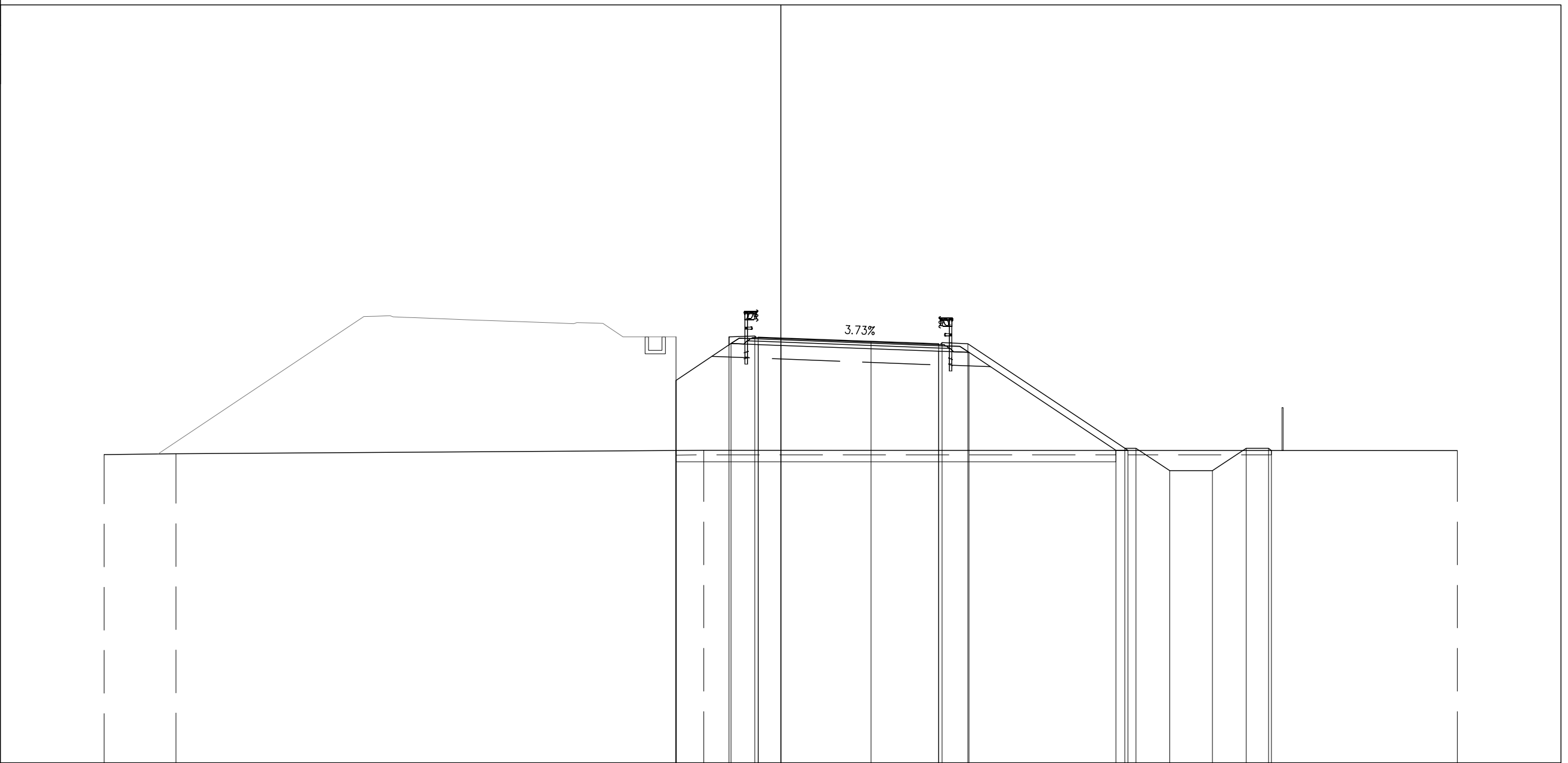

PROGRESSIVE TERRENO	-30.00	-26.81	-3.41																	30.00
PARZIALI TERRENO	3.19	23.40	33.41																	
QUOTE TERRENO	12.66	12.70	12.85																	12.84
PROGRESSIVE PROGETTO			-4.65	-2.30	-1.15	-1.00	0.00	4.00	4.00	7.00	7.15	8.30	15.25	15.75	17.25	19.15	20.64	21.64	21.76	
PARZIALI PROGETTO			2.35	1.15	0.15	1.00	4.00	3.00	0.15	1.15	6.95	0.50	1.50	1.90	1.49	1.00	0.12			
QUOTE PROGETTO			17.88	17.88	17.92	17.87	17.83	17.68	17.57	17.63	17.58	12.94	12.94	11.95	11.95	12.94	12.94	12.84		
PROGRESSIVE RILEVATO			-4.65	-2.20	-1.00	0.00	7.00	8.34	14.86	15.40	17.25	19.15	20.64	21.64	21.76					
PARZIALI RILEVATO			2.45	1.20	1.00	7.00	1.34	6.52	0.54											
QUOTE RILEVATO			15.95	17.58	17.54	17.50	17.24	17.19	12.85	12.85	17.19	12.85								

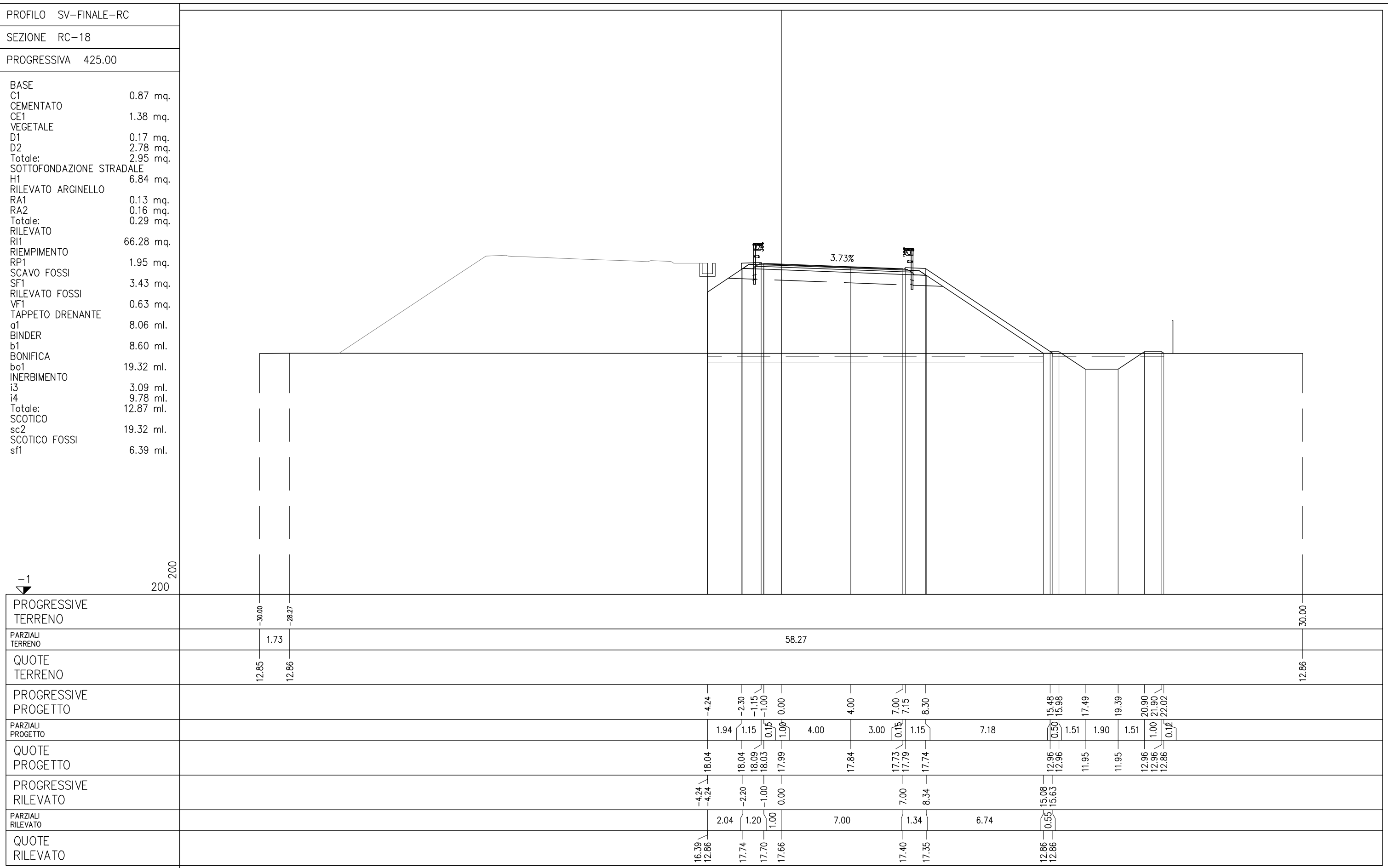

PROFILO SV-FINALE-RC
 SEZIONE RC-19
 PROGRESSIVA 450.00

- BASE
- C1 1.01 mq.
- CEMENTATO
- CE1 1.53 mq.
- VEGETALE
- D1 2.80 mq.
- SOTTOFONDAZIONE STRADALE
- H1 6.87 mq.
- RILEVATO ARGINELLO
- RA1 0.16 mq.
- RILEVATO
- RI1 61.70 mq.
- SCAVO FOSSI
- SF1 3.50 mq.
- RILEVATO FOSSI
- VF1 0.64 mq.
- TAPPETO DRENANTE
- a1 9.66 ml.
- BINDER
- b1 9.93 ml.
- BONIFICA
- bo1 17.88 ml.
- INERBIMENTO
- i3 9.97 ml.
- SCOTICO
- sc2 17.88 ml.
- SCOTICO FOSSI
- sf1 6.43 ml.

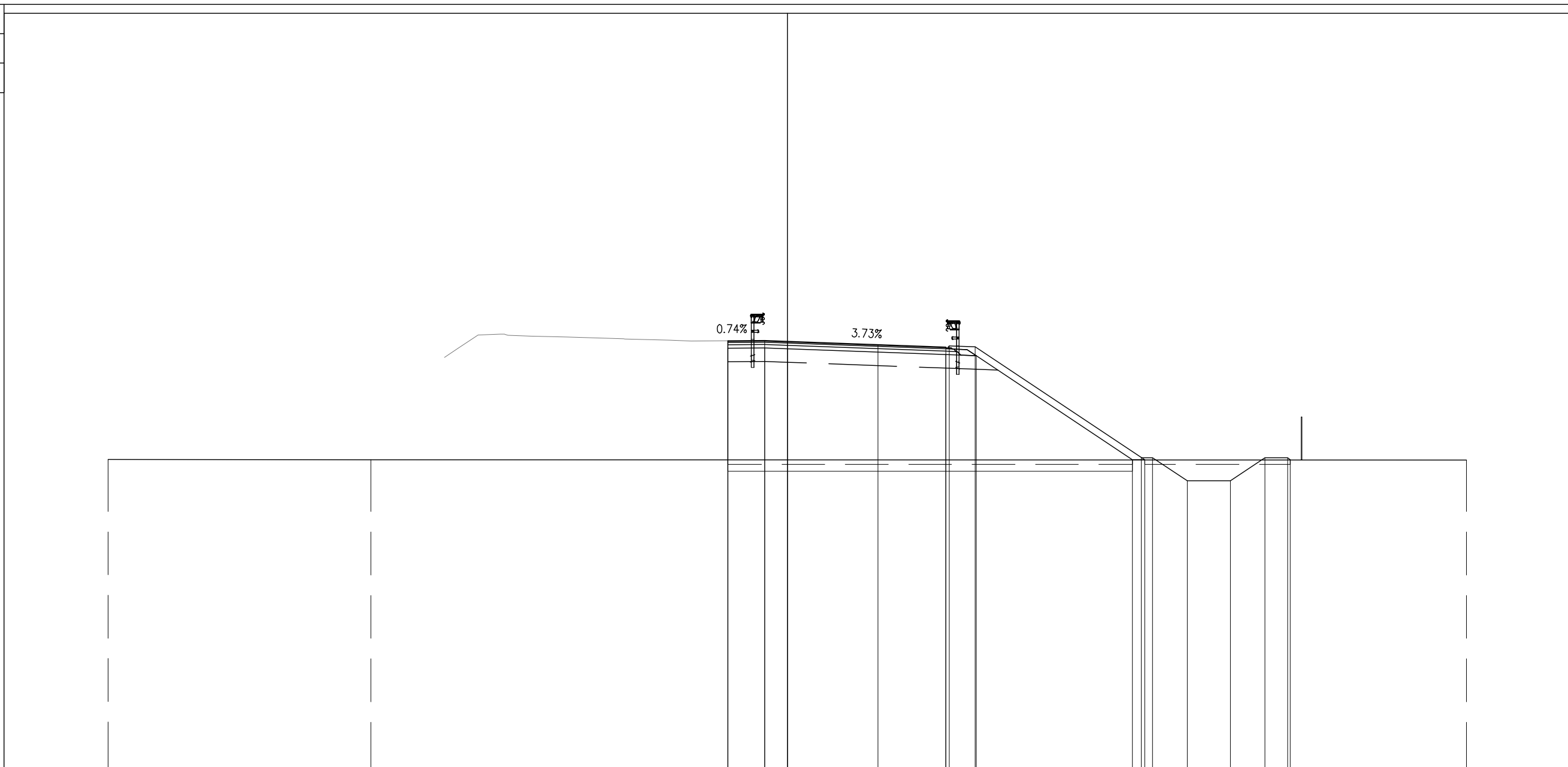

PROGRESSIVE TERRENO	-30.00	-18.40											30.00					
PARZIALI TERRENO	11.60		48.40															
QUOTE TERRENO	12.89	12.88											12.87					
PROGRESSIVE PROGETTO			-2.63	-1.00	0.00	4.00	4.00	7.00	7.15	8.30		15.64	16.14	17.67	19.57	21.10	22.10	22.22
PARZIALI PROGETTO			1.63	1.00	4.00	3.00	0.15	1.15	7.34	0.50	1.53	1.90	1.53	1.00	22.10	0.12		
QUOTE PROGETTO			18.14	18.15	18.11	17.97	17.85	17.91	17.86		12.97	12.97	11.95	11.95	12.97	12.87		
PROGRESSIVE RILEVATO			-2.63	-1.00	0.00	7.00	8.34				15.25	15.79						
PARZIALI RILEVATO			1.63	1.00	7.00	1.34	6.91	0.54										
QUOTE RILEVATO			17.81	17.82	17.78	17.52	17.47				12.87	12.87						

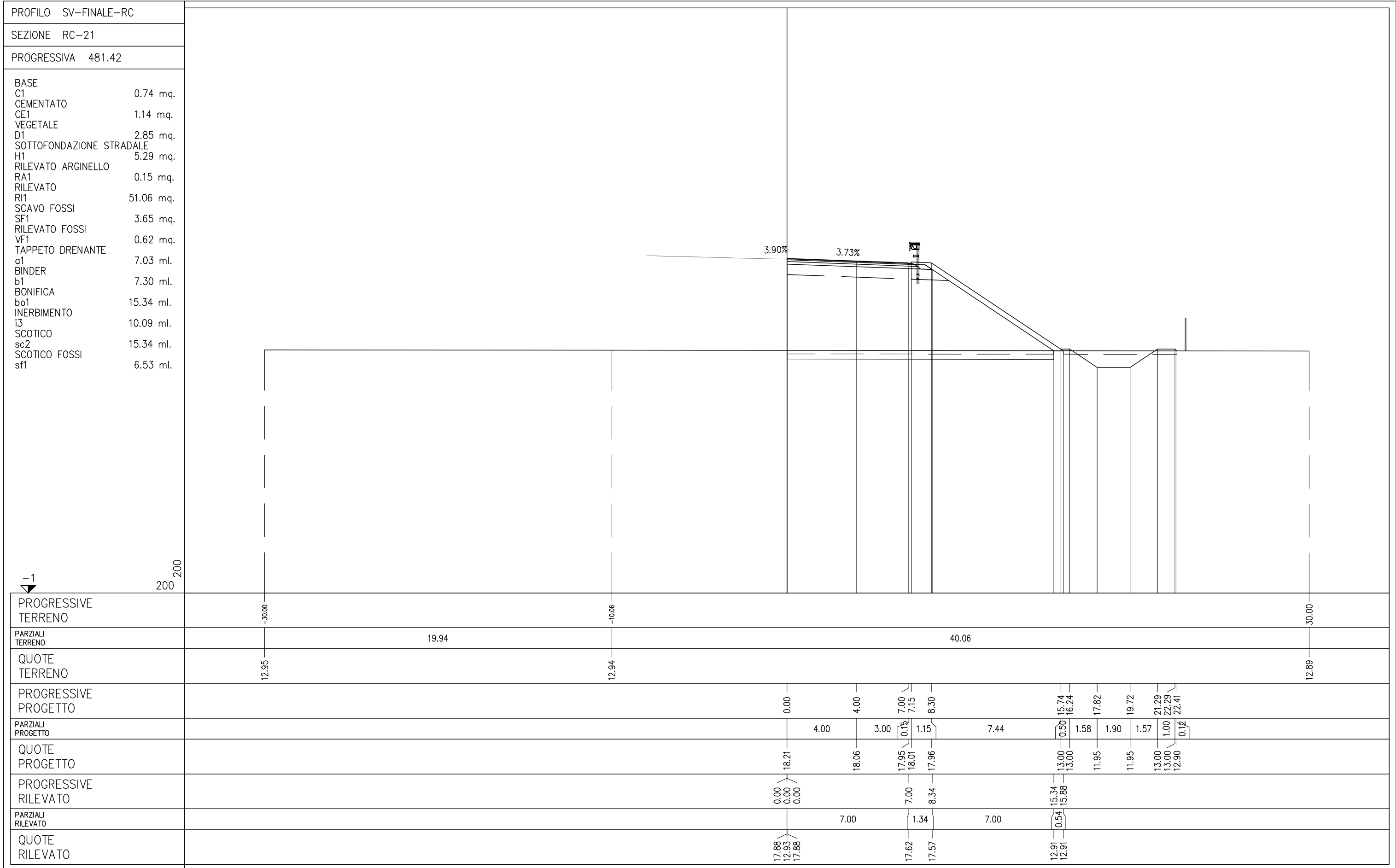

PROFILO SV-FINALE-RC	
SEZIONE RC-21	
PROGRESSIVA 481.42	
BASE	
C1	0.74 mq.
CEMENTATO	
CE1	1.14 mq.
VEGETALE	
D1	2.85 mq.
SOTTOFONDAZIONE STRADALE	
H1	5.29 mq.
RILEVATO ARGINELLO	
RA1	0.15 mq.
RILEVATO	
RI1	51.06 mq.
SCAVO FOSSI	
SF1	3.65 mq.
RILEVATO FOSSI	
VF1	0.62 mq.
TAPPETO DRENANTE	
a1	7.03 ml.
BINDER	
b1	7.30 ml.
BONIFICA	
bo1	15.34 ml.
INERBIMENTO	
i3	10.09 ml.
SCOTICO	
sc2	15.34 ml.
SCOTICO FOSSI	
sf1	6.53 ml.

-1
200
200

	-30.00		-10.06															30.00
PROGRESSIVE TERRENO																		
PARZIALI TERRENO		19.94				40.06												
QUOTE TERRENO	12.95		12.94															12.89
PROGRESSIVE PROGETTO					0.00	4.00	7.00	7.15	8.30		15.74	16.24	17.82	19.72	21.29	22.29	22.41	
PARZIALI PROGETTO					4.00	3.00	0.15	1.15	7.44	0.50	1.58	1.90	1.57	1.00	1.00	0.12		
QUOTE PROGETTO					18.21	18.06	17.95	18.01	17.96		13.00	13.00	11.95	11.95	13.00	13.00	12.90	
PROGRESSIVE RILEVATO					0.00	0.00	0.00	7.00	8.34		15.34	15.88						
PARZIALI RILEVATO					7.00			1.34	7.00	0.54								
QUOTE RILEVATO	17.88	12.93	17.88		17.62	17.57				12.91	12.91							

PROFILO SV-FINALE-RC
 SEZIONE RC-22
 PROGRESSIVA 500.00

- BASE
- C1 0.74 mq.
- CEMENTATO
- CE1 1.14 mq.
- VEGETALE
- D1 2.84 mq.
- SOTTOFONDAZIONE STRADALE
- H1 5.26 mq.
- RILEVATO ARGINELLO
- RA1 0.15 mq.
- RILEVATO
- RI1 51.02 mq.
- SCAVO FOSSI
- SF1 3.87 mq.
- RILEVATO FOSSI
- VF1 0.65 mq.
- TAPPETO DRENANTE
- a1 7.01 ml.
- BINDER
- b1 7.28 ml.
- BONIFICA
- bo1 15.33 ml.
- INERBIMENTO
- i3 10.11 ml.
- SCOTICO
- sc2 15.33 ml.
- SCOTICO FOSSI
- sf1 6.65 ml.

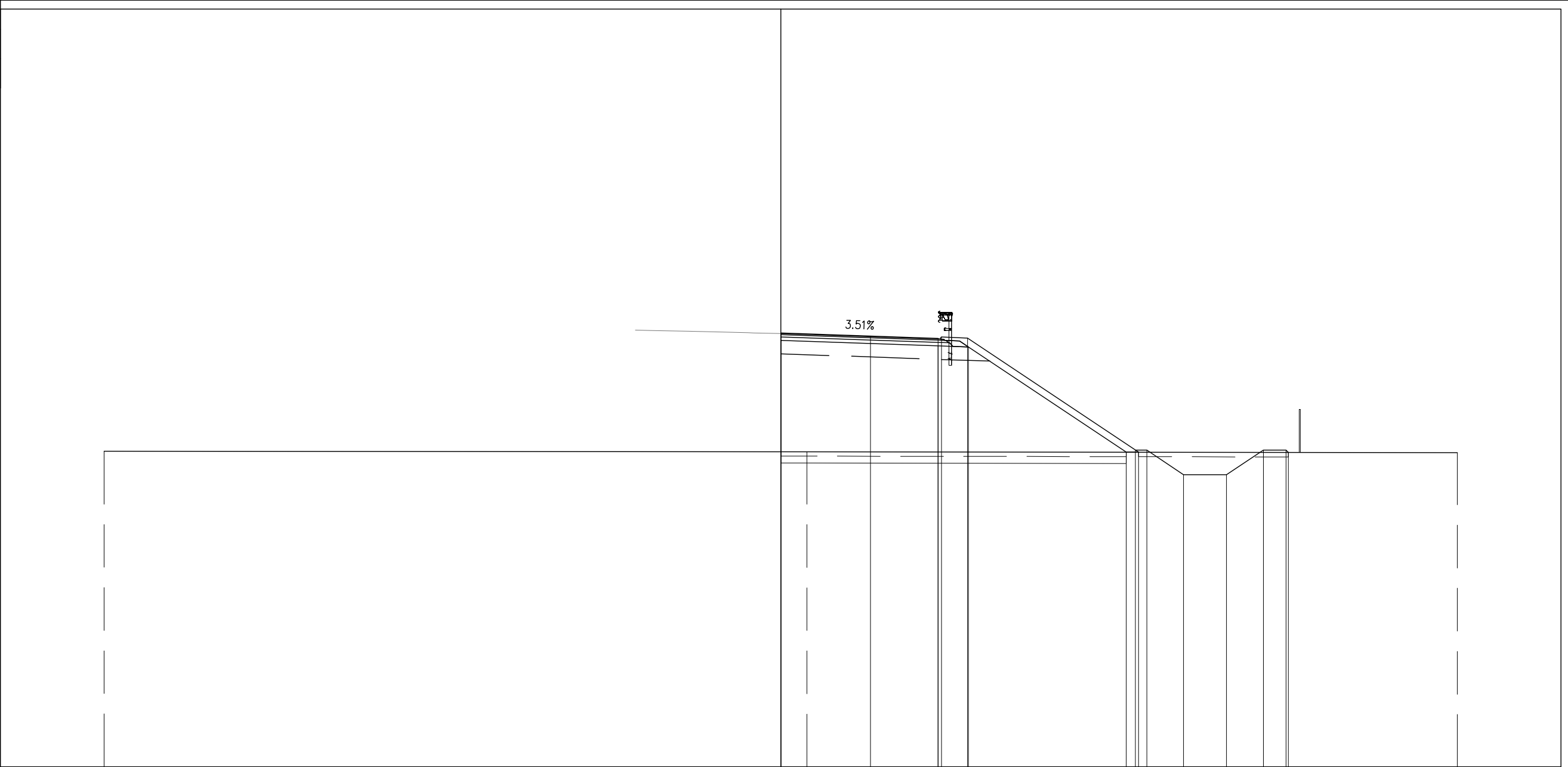

PROGRESSIVE TERRENO	-30.00	1.16	30.00
PARZIALI TERRENO	31.16	28.84	
QUOTE TERRENO	12.99	12.97	12.93
PROGRESSIVE PROGETTO	0.00	3.98	6.98
PARZIALI PROGETTO	3.98	3.00	7.45
QUOTE PROGETTO	18.24	18.10	18.00
PROGRESSIVE RILEVATO	0.00	6.98	8.32
PARZIALI RILEVATO	6.98	1.34	7.01
QUOTE RILEVATO	17.91	17.67	17.62

PROFILO SV-FINALE-RC
 SEZIONE RC-23
 PROGRESSIVA 525.00

- BASE
- C1 0.73 mq.
- CEMENTATO
- CE1 1.11 mq.
- VEGETALE
- D1 2.76 mq.
- SOTTOFONDAZIONE STRADALE
- H1 5.21 mq.
- RILEVATO ARGINELLO
- RA1 0.16 mq.
- RILEVATO
- RI1 50.37 mq.
- SCAVO FOSSI
- SF1 3.16 mq.
- RILEVATO FOSSI
- VF1 0.79 mq.
- TAPPETO DRENANTE
- a1 6.93 ml.
- BINDER
- b1 7.20 ml.
- BONIFICA
- bo1 15.22 ml.
- INERBIMENTO
- i3 10.42 ml.
- SCOTICO
- sc2 15.22 ml.
- SCOTICO FOSSI
- sf1 4.97 ml.

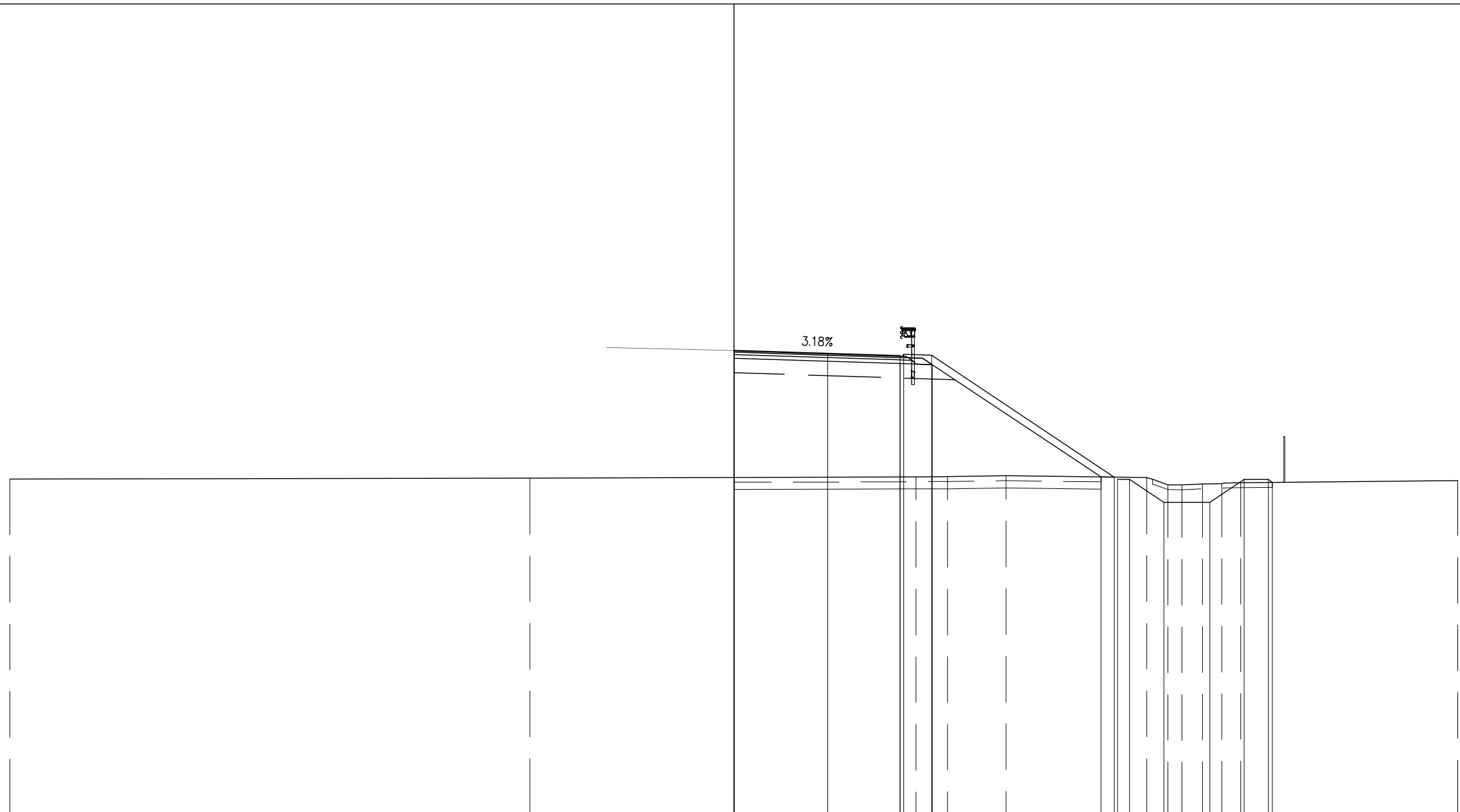

PROGRESSIVE TERRENO	-30.00	-8.45		7.55	8.86	11.28		17.12	17.99	18.58	19.42	20.22	21.01	30.00
PARZIALI TERRENO		21.55		16.00	1.31	2.42	5.84	0.87	0.59	0.84	0.80	0.79	8.99	
QUOTE TERRENO	12.92		12.96		13.00	13.01	13.05	12.97	12.68	12.67	12.71	12.73	12.76	12.85
PROGRESSIVE PROGETTO				0.00	3.89	6.89	7.04	8.19	15.90	16.40	17.83	19.73	21.15	22.32
PARZIALI PROGETTO				3.89	3.00	0.15	1.15	7.71	0.50	1.43	1.90	1.42	1.00	0.17
QUOTE PROGETTO				18.25	18.13	18.03	18.09	18.04	12.90	12.90	11.95	11.95	12.90	12.77
PROGRESSIVE RILEVATO				0.00	0.00	0.00	6.89	8.23	15.22	15.77				
PARZIALI RILEVATO				6.89	1.34	6.99			0.55					
QUOTE RILEVATO	17.92	12.98	17.92	17.70	17.66				13.00	12.99				

-1
 200 200

PROFILO SV-FINALE-RC
 SEZIONE RC-24
 PROGRESSIVA 550.00

- BASE
- C1 0.72 mq.
- CEMENTATO
- CE1 1.10 mq.
- VEGETALE
- D1 2.77 mq.
- SOTTOFONDAZIONE STRADALE
- H1 5.14 mq.
- RILEVATO ARGINELLO
- RA1 0.16 mq.
- RILEVATO
- RI1 50.60 mq.
- SCAVO FOSSI
- SF1 4.76 mq.
- RILEVATO FOSSI
- VF1 0.89 mq.
- TAPPETO DRENANTE
- a1 6.83 ml.
- BINDER
- b1 7.10 ml.
- BONIFICA
- bo1 15.08 ml.
- INERBIMENTO
- i3 9.91 ml.
- SCOTICO
- sc2 15.08 ml.
- SCOTICO FOSSI
- sf1 7.03 ml.

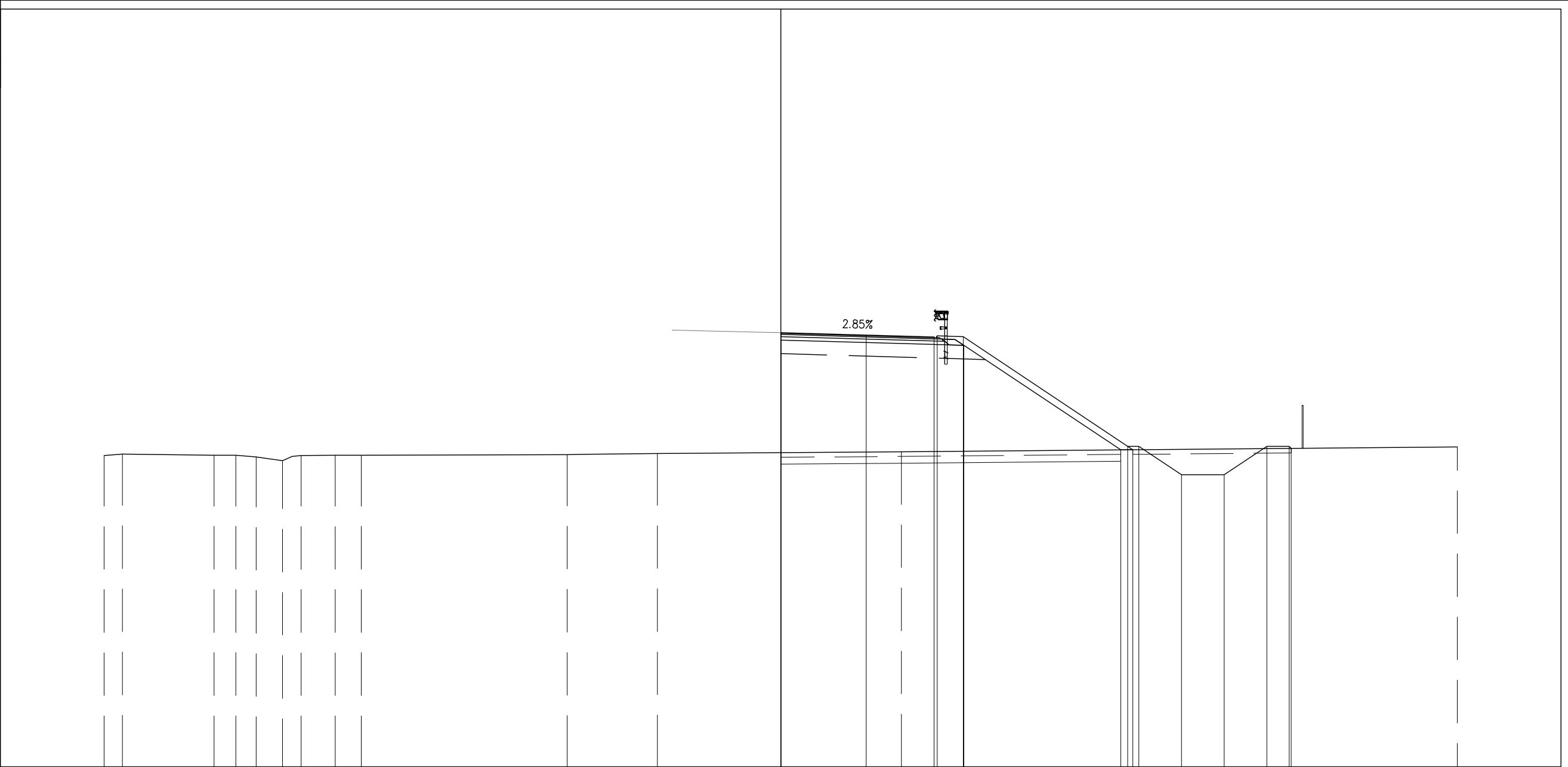

PROGRESSIVE TERRENO	-30.00	-29.19	-25.12	-24.16	-23.26	-22.09	-21.27	-19.76	-18.60	-9.47	-5.47	5.35	30.00										
PARZIALI TERRENO	0.81	4.07	0.96	0.90	1.17	0.82	1.51	1.16	9.13	4.00	10.82	24.65											
QUOTE TERRENO	12.81	12.87	12.82	12.82	12.73	12.57	12.80	12.81	12.82	12.83	12.89	12.96	13.18										
PROGRESSIVE PROGETTO										0.00	3.79	6.79	6.94	8.09	15.38	15.88	17.77	19.67	21.55	22.55	22.64		
PARZIALI PROGETTO										3.79	3.00	0.15	1.15	7.29	0.50	1.89	1.90	1.88	1.00	1.00	0.09		
QUOTE PROGETTO										18.25	18.14	18.06	18.11	18.07	13.21	13.21	11.95	11.95	13.21	13.21	13.12		
PROGRESSIVE RILEVATO										0.00	0.00	6.79	8.12	15.08	15.61								
PARZIALI RILEVATO											6.79	1.33	6.96	0.53									
QUOTE RILEVATO										17.92	12.93	17.73	17.69	13.05	13.05								

PROFILO SV-FINALE-RC
 SEZIONE RC-25
 PROGRESSIVA 576.14

- BASE
- C1 0.71 mq.
- CEMENTATO
- CE1 1.09 mq.
- VEGETALE
- D1 2.72 mq.
- SOTTOFONDAZIONE STRADALE
- H1 5.13 mq.
- RILEVATO ARGINELLO
- RA1 0.16 mq.
- RILEVATO
- RI1 48.32 mq.
- SCAVO FOSSI
- SF1 5.84 mq.
- RILEVATO FOSSI
- VF1 0.95 mq.
- TAPPETO DRENANTE
- a1 6.78 ml.
- BINDER
- b1 7.05 ml.
- BONIFICA
- bo1 14.81 ml.
- INERBIMENTO
- i3 9.63 ml.
- SCOTICO
- sc2 14.81 ml.
- SCOTICO FOSSI
- sf1 7.56 ml.

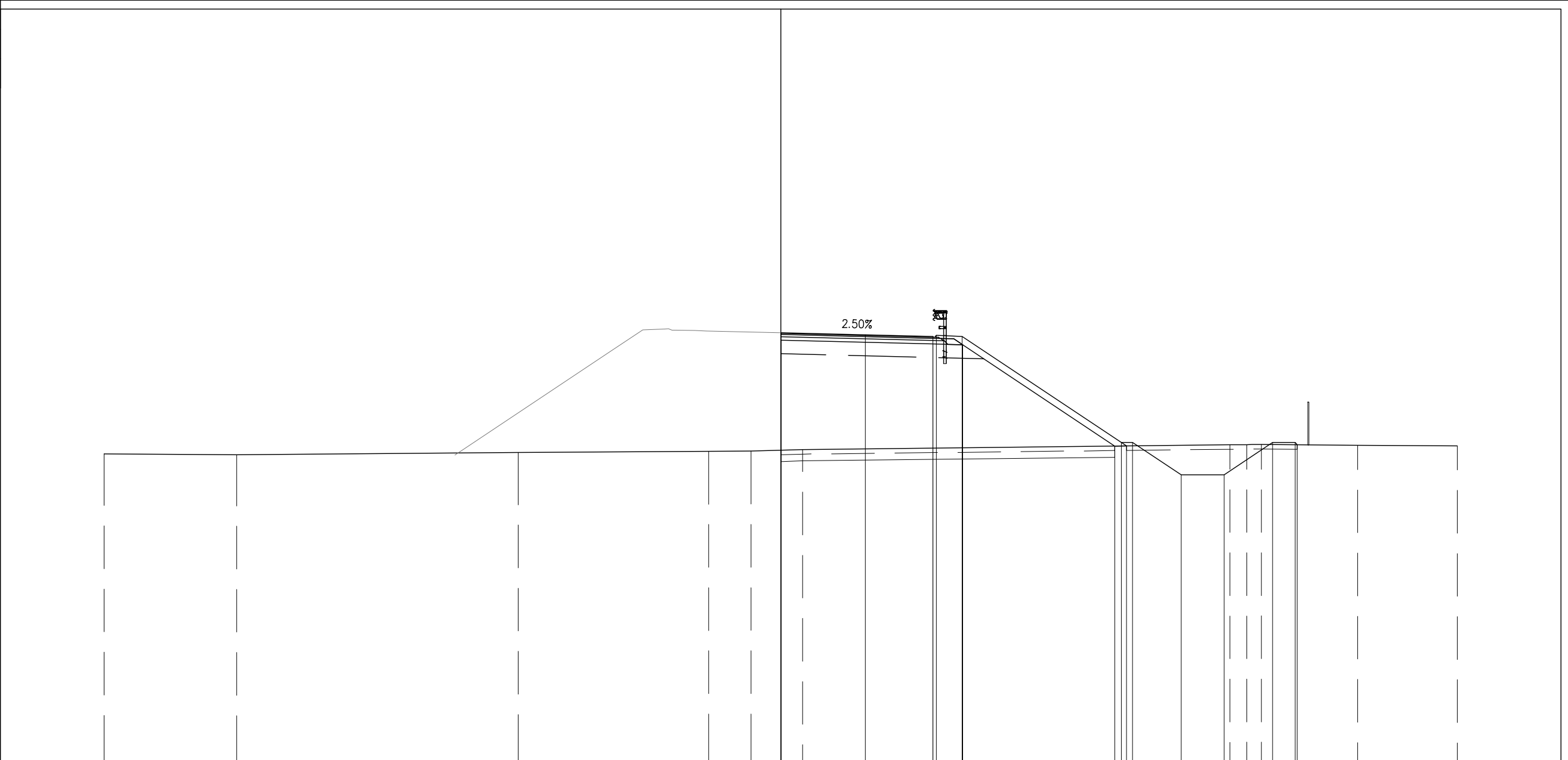

PROGRESSIVE TERRENO	-30.00	-24.13	-11.64	-3.19	-1.31	0.96						19.92	20.67	21.31	25.59	30.00	
PARZIALI TERRENO	5.87	12.49	8.45	1.88	2.27	18.96	0.75	0.64	4.28	4.41							
QUOTE TERRENO	12.88	12.84	12.94	12.99	13.00	13.07						13.28	13.29	13.29	13.26	13.23	
PROGRESSIVE PROGETTO						0.00	3.75	6.75	6.90	8.05		15.11	15.61	17.76	19.66		
PARZIALI PROGETTO						3.75	3.00	0.16	1.15	7.06	0.50	2.15	1.90	2.15	2.15	1.00	0.09
QUOTE PROGETTO						18.25	18.15	18.08	18.14	18.09		13.39	13.39	11.95	11.95	13.39	13.28
PROGRESSIVE RILEVATO						0.00	0.00	6.75	8.07		14.81	15.34					
PARZIALI RILEVATO						6.75	1.32	6.74		0.53							
QUOTE RILEVATO						17.92	13.04	17.92		17.75	17.72	13.22	13.23				

PROFILO SV-FINALE-RC
 SEZIONE RC-26
 PROGRESSIVA 590.07

- BASE
- C1 0.71 mq.
- CEMENTATO
- CE1 1.09 mq.
- VEGETALE
- D1 2.81 mq.
- SOTTOFONDAZIONE STRADALE
- H1 5.13 mq.
- RILEVATO ARGINELLO
- RA1 0.16 mq.
- RILEVATO
- RI1 49.13 mq.
- SCAVO FOSSI
- SF1 4.60 mq.
- RILEVATO FOSSI
- VF1 0.77 mq.
- TAPPETO DRENANTE
- a1 6.78 ml.
- BINDER
- b1 7.05 ml.
- BONIFICA
- bo1 15.05 ml.
- INERBIMENTO
- i3 10.00 ml.
- SCOTICO
- sc2 15.05 ml.
- SCOTICO FOSSI
- sf1 7.01 ml.

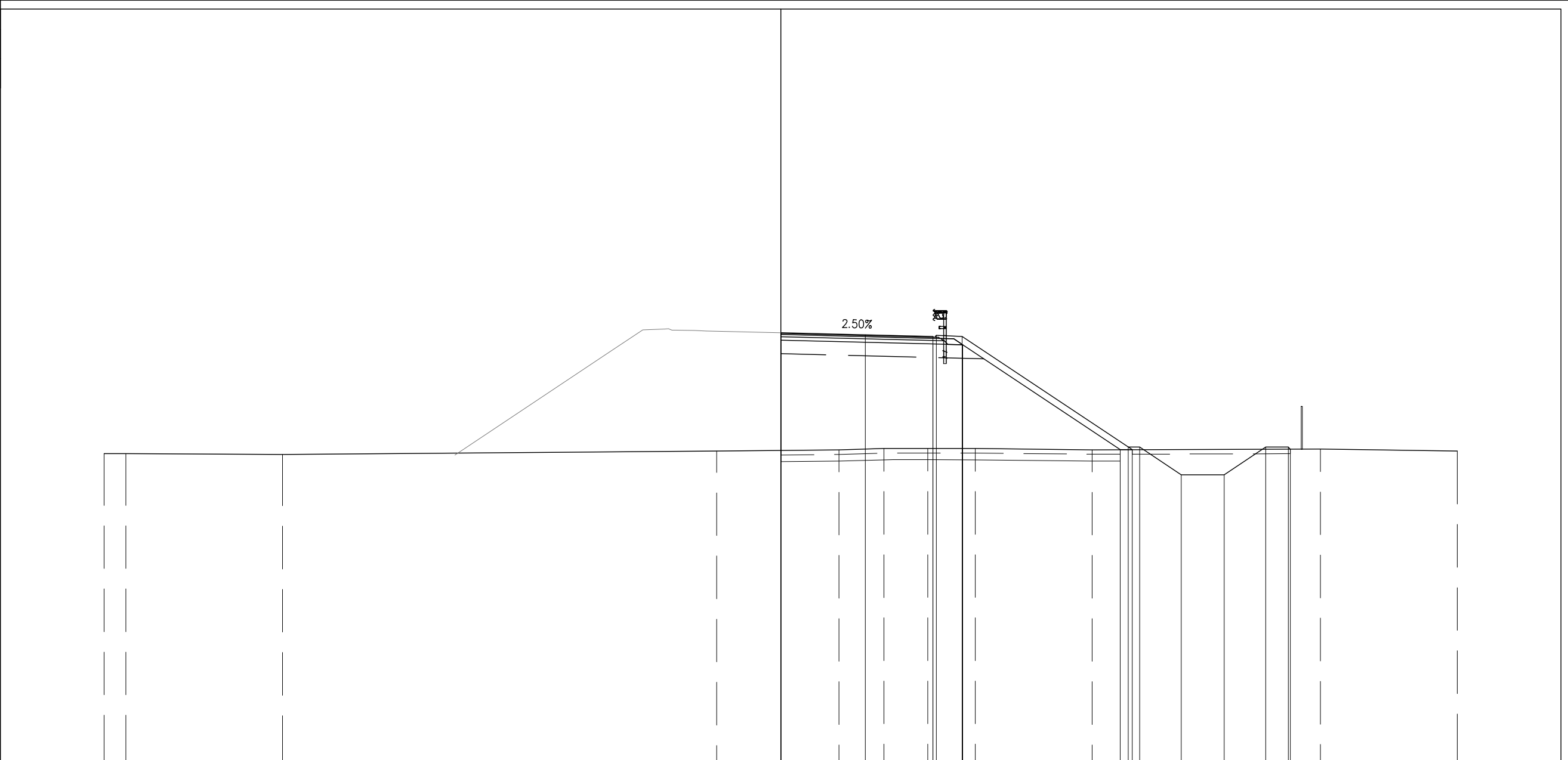

PROGRESSIVE TERRENO	-30.00	-29.04	-22.09	-2.84	2.59	4.58	6.52	8.63	13.80	23.94	30.00			
PARZIALI TERRENO	0.96	6.95	19.25	5.43	1.99	1.94	2.11	5.17	10.14	6.06				
QUOTE TERRENO	12.89	12.89	12.85	13.00	13.05	13.11	13.12	13.12	13.06	13.09	13.00			
PROGRESSIVE PROGETTO				0.00	3.75	6.75	6.90	8.05	15.41	17.76	19.66	21.51	22.51	22.60
PARZIALI PROGETTO				3.75	3.00	0.15	1.15	7.36	0.50	1.85	1.90	1.85	1.00	0.09
QUOTE PROGETTO				18.25	18.15	18.08	18.14	18.09	13.18	11.95	11.95	13.18	13.08	
PROGRESSIVE RILEVATO				0.00	0.00	6.75	8.07	15.05	15.59	17.76	19.66	21.51	22.51	22.60
PARZIALI RILEVATO				6.75	1.32	6.98	0.54	0.54	1.85	1.90	1.85	1.00	0.09	
QUOTE RILEVATO				17.92	13.03	17.75	17.72	13.06	13.06	11.95	11.95	13.18	13.08	

SVINCOLO DI SAN FELICE SUL PANARO - FINALE EMILIA
RAMO SR
SAT03

PROFILO SV-FINALE-SR

SEZIONE SR-1

PROGRESSIVA 0.00

BASE	
C1	2.64 mq.
CEMENTATO	
CE1	4.00 mq.
VEGETALE	
D1	2.87 mq.
D2	2.81 mq.
Totale:	5.68 mq.
SOTTOFONDAZIONE STRADALE	
H1	17.52 mq.
RILEVATO ARGINELLO	
RA1	0.16 mq.
RA2	0.16 mq.
Totale:	0.32 mq.
RILEVATO	
R11	154.84 mq.
SCAVO FOSSI	
SF1	4.58 mq.
SF2	3.58 mq.
Totale:	8.16 mq.
RILEVATO FOSSI	
VF1	0.74 mq.
VF2	0.65 mq.
Totale:	1.39 mq.
TAPPETO DRENANTE	
a1	25.66 ml.
BINDER	
b1	26.20 ml.
BONIFICA	
bo1	42.48 ml.
INERBIMENTO	
i5	10.36 ml.
i6	10.03 ml.
Totale:	20.39 ml.
SCOTICO	
sc3	42.48 ml.
SCOTICO FOSSI	
sf1	7.01 ml.
sf2	6.49 ml.
Totale:	13.50 ml.

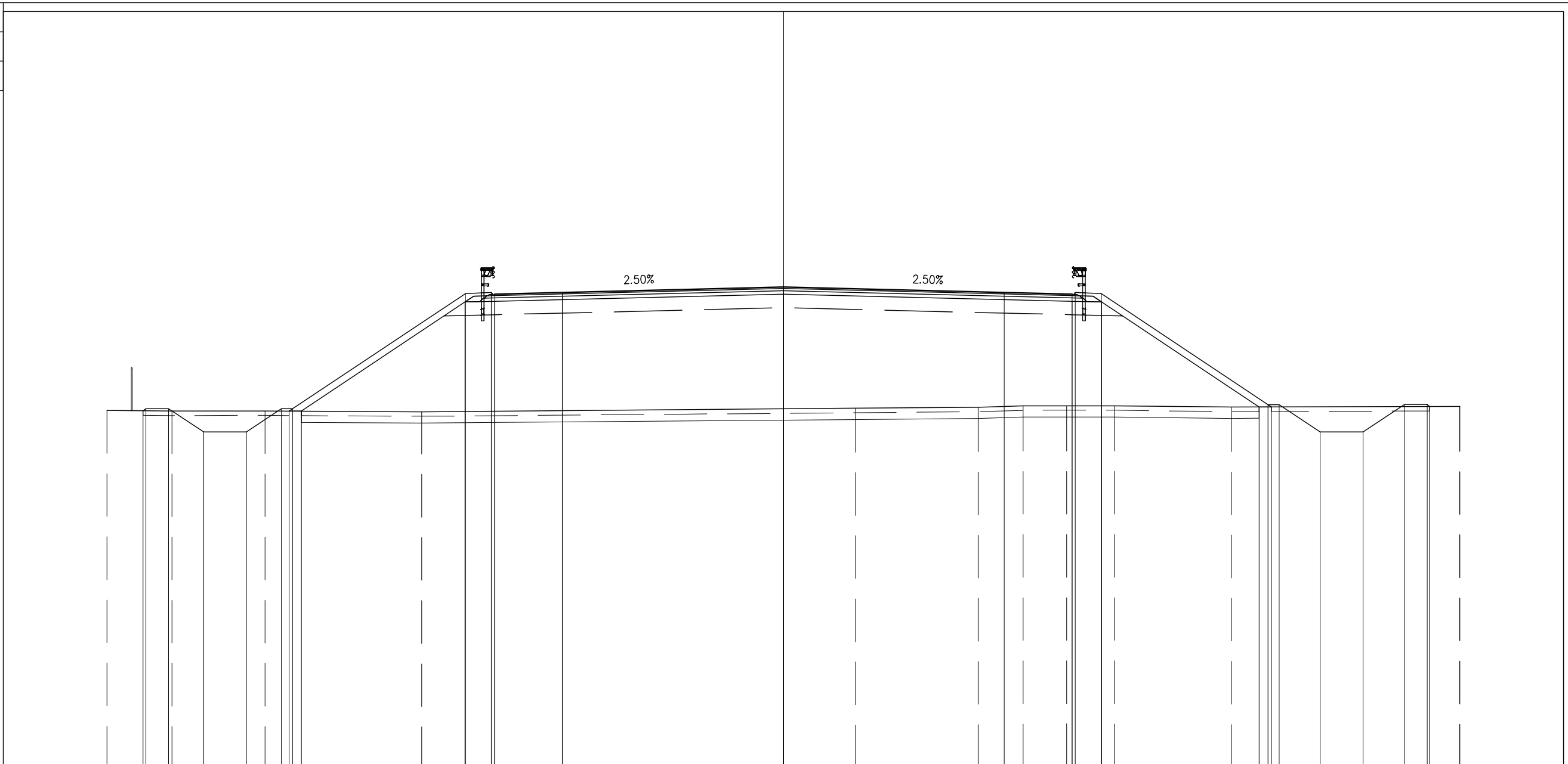

PROGRESSIVE TERRENO	-30.00	-27.12	-22.99	-16.04	3.21	8.64	10.63	12.57	14.69	19.86	29.99	30.00											
PARZIALI TERRENO	2.88	4.13	6.95	19.25	5.43	1.99	1.94	2.12	5.17	10.13	0.01												
QUOTE TERRENO	12.91	12.88	12.89	12.85	13.00	13.05	13.11	13.12	13.12	13.06	13.09	13.09											
PROGRESSIVE PROGETTO	-28.40	-27.26	-25.71	-23.81	-22.26	-21.76	-14.10	-12.95	-12.80	-9.80	0.00	12.80	12.95	14.10	21.49	21.99	23.81	25.71	27.56	28.56	28.65		
PARZIALI PROGETTO	0.14	1.00	1.55	1.90	1.55	0.50	7.66	1.15	0.15	3.00	9.80	9.80	3.00	0.15	1.15	7.39	0.50	1.82	1.90	1.85	1.00	0.09	
QUOTE PROGETTO	12.90	12.99	12.99	11.95	11.95	12.98	12.98	18.09	18.14	18.08	18.15	18.40	18.15	18.08	18.14	18.09	13.16	13.16	11.95	11.95	13.18	13.18	13.08
PROGRESSIVE RILEVATO	-21.91	-21.38	-14.12	-12.80	0.00	12.80	14.12	21.10	21.64	23.81	25.71	27.56	28.56	28.65									
PARZIALI RILEVATO	0.53	7.26	1.32	12.80	12.80	1.32	6.98	0.54															
QUOTE RILEVATO	12.88	12.88	17.72	17.75	18.07	17.75	17.72	13.06	13.06														

PROFILO SV-FINALE-SR

SEZIONE SR-5

PROGRESSIVA 98.42

BASE	
C1	2.64 mq.
CEMENTATO	
CE1	4.00 mq.
VEGETALE	
D1	0.64 mq.
D2	1.72 mq.
Totale:	2.36 mq.
SOTTOFONDAZIONE STRADALE	
H1	17.50 mq.
RILEVATO ARGINELLO	
RA1	0.15 mq.
RA2	0.15 mq.
Totale:	0.30 mq.
RILEVATO	
R11	77.44 mq.
SCAVO FOSSI	
SF1	2.07 mq.
RILEVATO FOSSI	
VF1	4.41 mq.
TAPPETO DRENANTE	
a1	25.66 ml.
BINDER	
b1	26.20 ml.
BONIFICA	
bo1	36.58 ml.
INERBIMENTO	
i3	3.01 ml.
i4	5.17 ml.
Totale:	8.18 ml.
SCOTICO	
sc2	36.58 ml.
SCOTICO FOSSI	
sf1	5.48 ml.

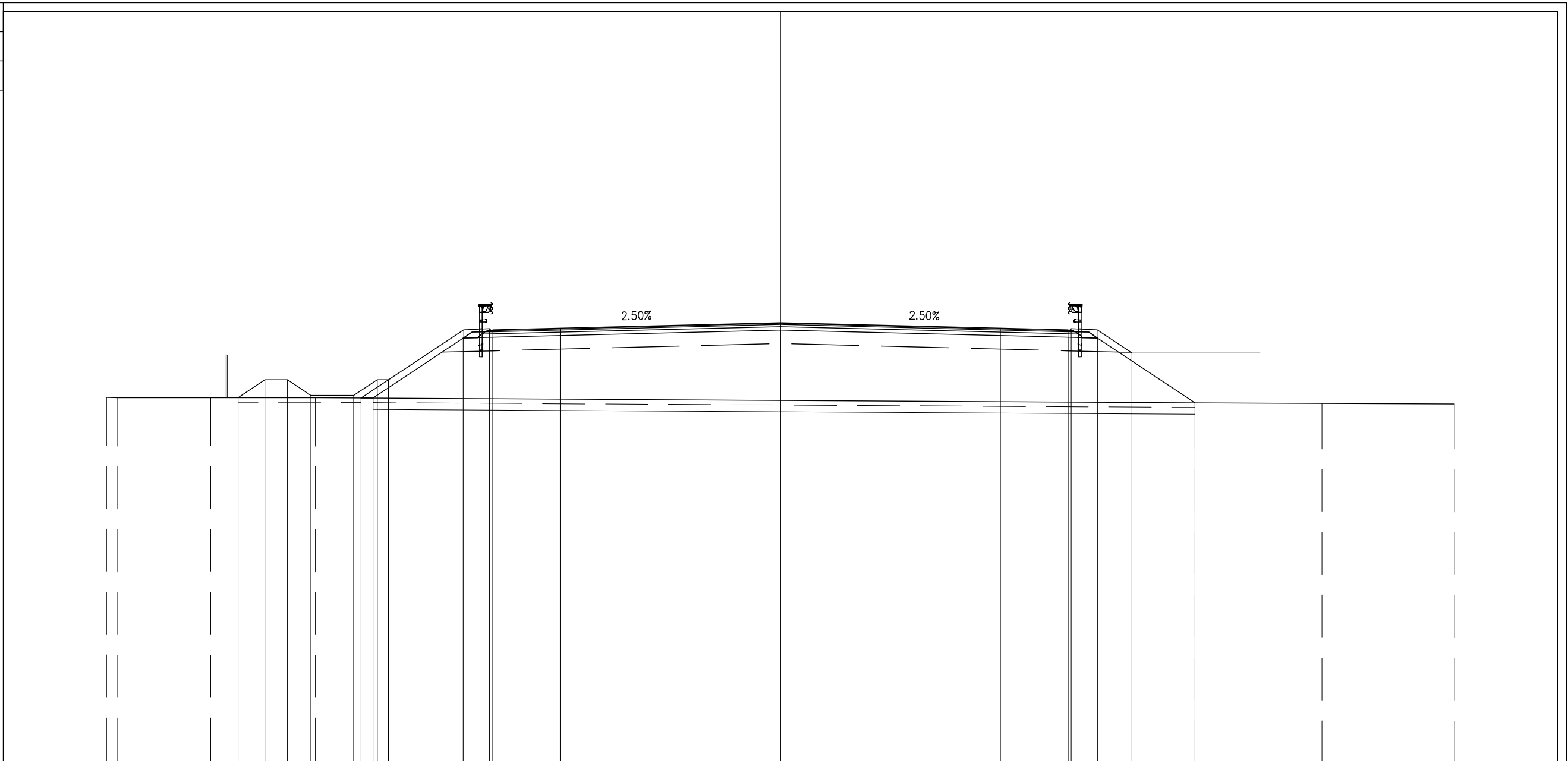

PROGRESSIVE TERRENO	-30.00	-29.50	-25.36	-20.70															18.40	24.11	30.00		
PARZIALI TERRENO	0.50	4.14	4.66						39.10										5.71	5.89			
QUOTE TERRENO	13.41	13.40	13.40	13.40															13.17	13.14	13.12		
PROGRESSIVE PROGETTO			-24.15	-22.95	-21.95	-20.90	-19.00	-17.95	-17.45	-14.10	-12.95	-12.80	-9.80	0.00					9.80	12.80	12.95	14.10	15.65
PARZIALI PROGETTO			1.20	1.00	1.05	1.90	1.05	0.50	3.35	1.15	0.15	3.00			9.80				3.00	0.15	1.15	1.55	
QUOTE PROGETTO			13.40	14.20	14.20	13.50	13.50	14.20	14.20	16.43	16.48	16.42	16.50	16.74		16.50			16.50	16.42	16.48	16.43	15.40
PROGRESSIVE RILEVATO						-18.67	-18.13	-14.12	-12.80	0.00										12.80	14.12	18.45	
PARZIALI RILEVATO						0.51	4.01	1.32							12.80					1.32	4.33		
QUOTE RILEVATO						13.39	13.39	16.06	16.09	16.41					16.41					16.09	16.06	13.17	

PROFILO SV-FINALE-SR

SEZIONE SR-6

PROGRESSIVA 125.00

- BASE
- C1 4.26 mq.
- CEMENTATO
- CE1 6.43 mq.
- VEGETALE
- D1 0.24 mq.
- D2 1.20 mq.
- Totale: 1.44 mq.
- SOTTOFONDAZIONE STRADALE
- H1 27.19 mq.
- RILEVATO ARGINELLO
- RA1 0.15 mq.
- RA2 0.15 mq.
- Totale: 0.30 mq.
- RILEVATO
- R11 73.13 mq.
- SCAVO FOSSI
- SF1 2.07 mq.
- RILEVATO FOSSI
- VF1 3.68 mq.
- TAPPETO DRENANTE
- a1 41.81 ml.
- BINDER
- b1 42.35 ml.
- BONIFICA
- bo1 49.84 ml.
- INERBIMENTO
- i3 1.45 ml.
- i4 3.69 ml.
- Totale: 5.14 ml.
- SCOTICO
- sc2 49.84 ml.
- SCOTICO FOSSI
- sf1 5.54 ml.

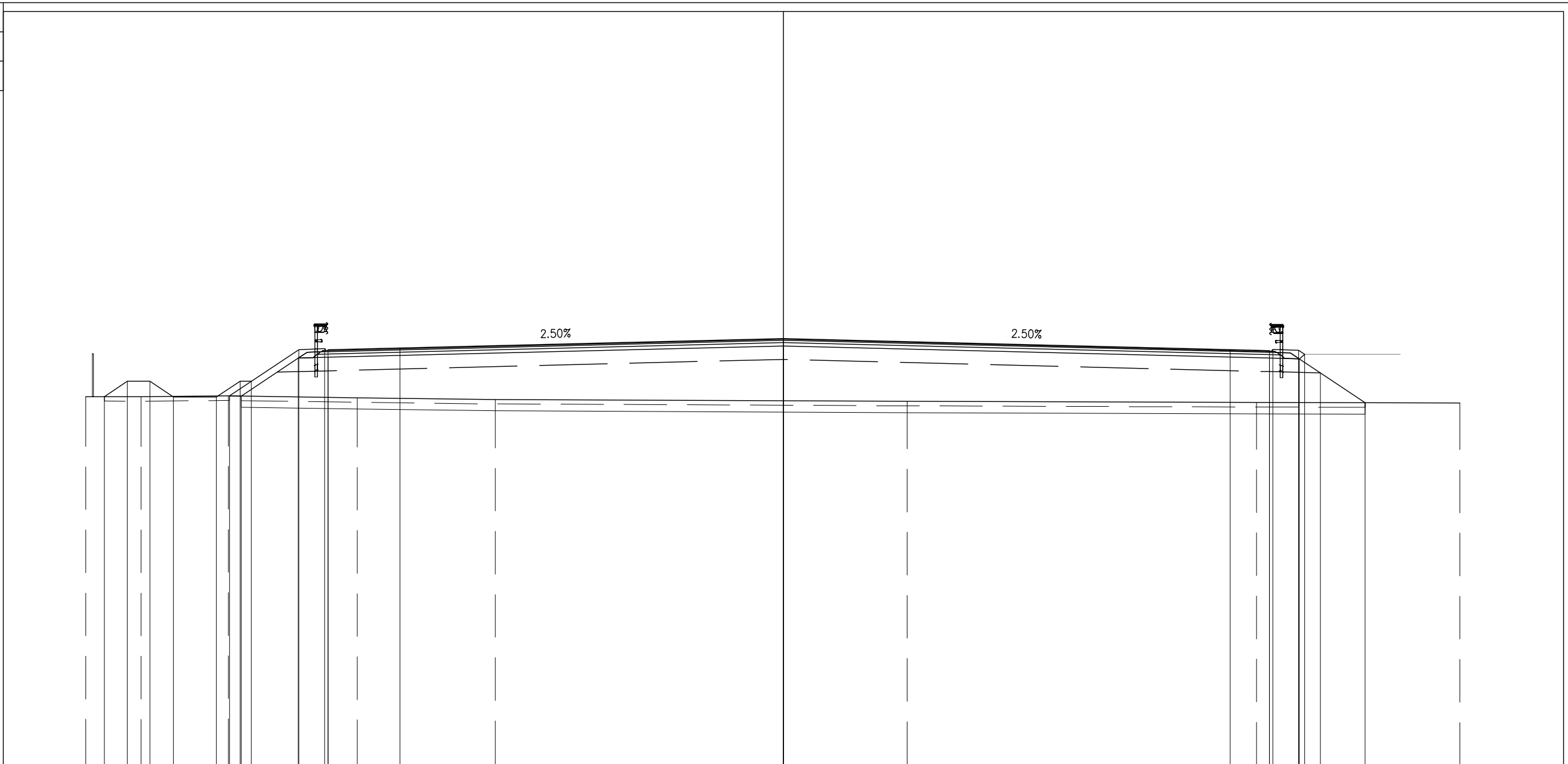

PROGRESSIVE TERRENO	-30.93	-28.49	-24.62	-18.89	-12.78	5.49	20.98	30.00									
PARZIALI TERRENO	2.44	3.87	5.73	6.11	18.27	15.49	9.02										
QUOTE TERRENO	13.52	13.52	13.55	13.47	13.40	13.31	13.26	13.24									
PROGRESSIVE PROGETTO	-30.11	-29.10	-28.10	-27.05	-25.15	-24.10	-23.60	-21.49	-20.34	-20.19	0.00	19.82	21.56	21.71	22.86	23.11	
PARZIALI PROGETTO	1.01	1.00	1.05	1.90	1.05	0.50	2.11	1.15	0.15	3.18	17.01	19.82	1.74	0.15	1.15	0.25	
QUOTE PROGETTO	13.52	14.20	14.20	13.50	13.50	14.20	14.20	15.61	15.65	15.60	15.67	16.10	15.60	15.56	15.62	15.57	15.40
PROGRESSIVE RILEVATO			-24.57	-24.04	-21.51	-20.19	0.00	21.56	22.88	23.81	25.80						
PARZIALI RILEVATO			0.53	2.53	1.32		20.19	21.56	1.32	0.93	1.99						
QUOTE RILEVATO			13.55	13.55	15.23	15.27	15.77	15.77	15.20	14.57	13.25						

PROFILO SV-FINALE-SR
 SEZIONE SR-7
 PROGRESSIVA 148.42

- BASE
- C1 5.49 mq.
- CEMENTATO
- CE1 8.24 mq.
- VEGETALE
- D2 1.09 mq.
- SOTTOFONDAZIONE STRADALE
- H1 33.72 mq.
- RILEVATO ARGINELLO
- RA1 0.15 mq.
- RILEVATO
- RI1 72.34 mq.
- SCAVO FOSSI
- SF1 2.07 mq.
- RILEVATO FOSSI
- VF1 3.46 mq.
- TAPPETO DRENANTE
- a1 54.43 ml.
- BINDER
- b1 54.70 ml.
- BONIFICA
- bo1 57.92 ml.
- INERBIMENTO
- i4 3.35 ml.
- SCOTICO
- sc2 57.92 ml.
- SCOTICO FOSSI
- sf1 5.51 ml.

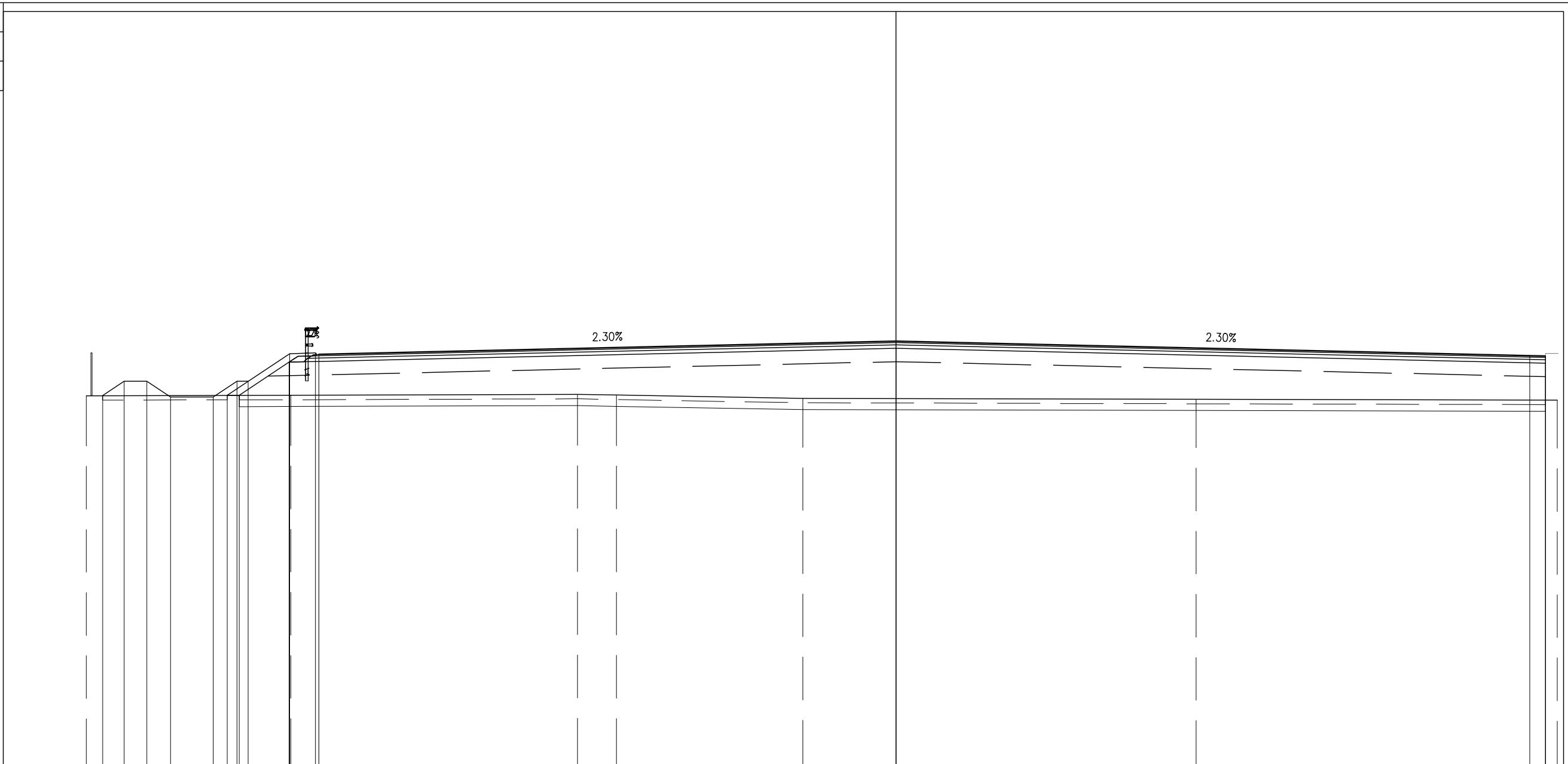

PROGRESSIVE TERRENO	-35.92		-26.84		-14.13	-12.40		-4.13		13.31	29.32		
PARZIALI TERRENO		9.08		12.71	1.73	8.27		17.44		16.01			
QUOTE TERRENO	13.56		13.58		13.62	13.59		13.45		13.41	13.36		
PROGRESSIVE PROGETTO	-35.18	-34.23	-33.23	-32.18	-30.28	-28.23	-28.73	-26.90	-25.75	-25.60	0.00	28.10	28.80
PARZIALI PROGETTO		0.95	1.00	1.05	1.90	1.05	0.50	1.83	1.15	0.15	25.60	28.10	0.70
QUOTE PROGETTO	13.56	14.20	14.20	13.50	13.50	14.20	14.20	15.42	15.47	15.41	16.00	15.35	15.34
PROGRESSIVE RILEVATO					-26.67	-28.12		-26.91	-25.60		0.00	28.80	28.80
PARZIALI RILEVATO					0.55	2.21		1.31			25.60	28.80	
QUOTE RILEVATO					13.58	13.58		15.05	15.08		15.67	13.36	15.01

PROFILO SV-FINALE-SR

SEZIONE SR-8

PROGRESSIVA 178.67

- BASE
- C1 5.55 mq.
- CEMENTATO
- CE1 8.35 mq.
- VEGETALE
- D2 1.06 mq.
- SOTTOFONDAZIONE STRADALE
- H1 34.13 mq.
- RILEVATO ARGINELLO
- RA1 0.17 mq.
- RILEVATO
- RI1 67.70 mq.
- SCAVO FOSSI
- SF1 2.07 mq.
- RILEVATO FOSSI
- VF1 3.14 mq.
- TAPPETO DRENANTE
- a1 55.13 ml.
- BINDER
- b1 55.40 ml.
- BONIFICA
- bo1 58.62 ml.
- INERBIMENTO
- i4 3.47 ml.
- SCOTICO
- sc2 58.62 ml.
- SCOTICO FOSSI
- sf1 5.54 ml.

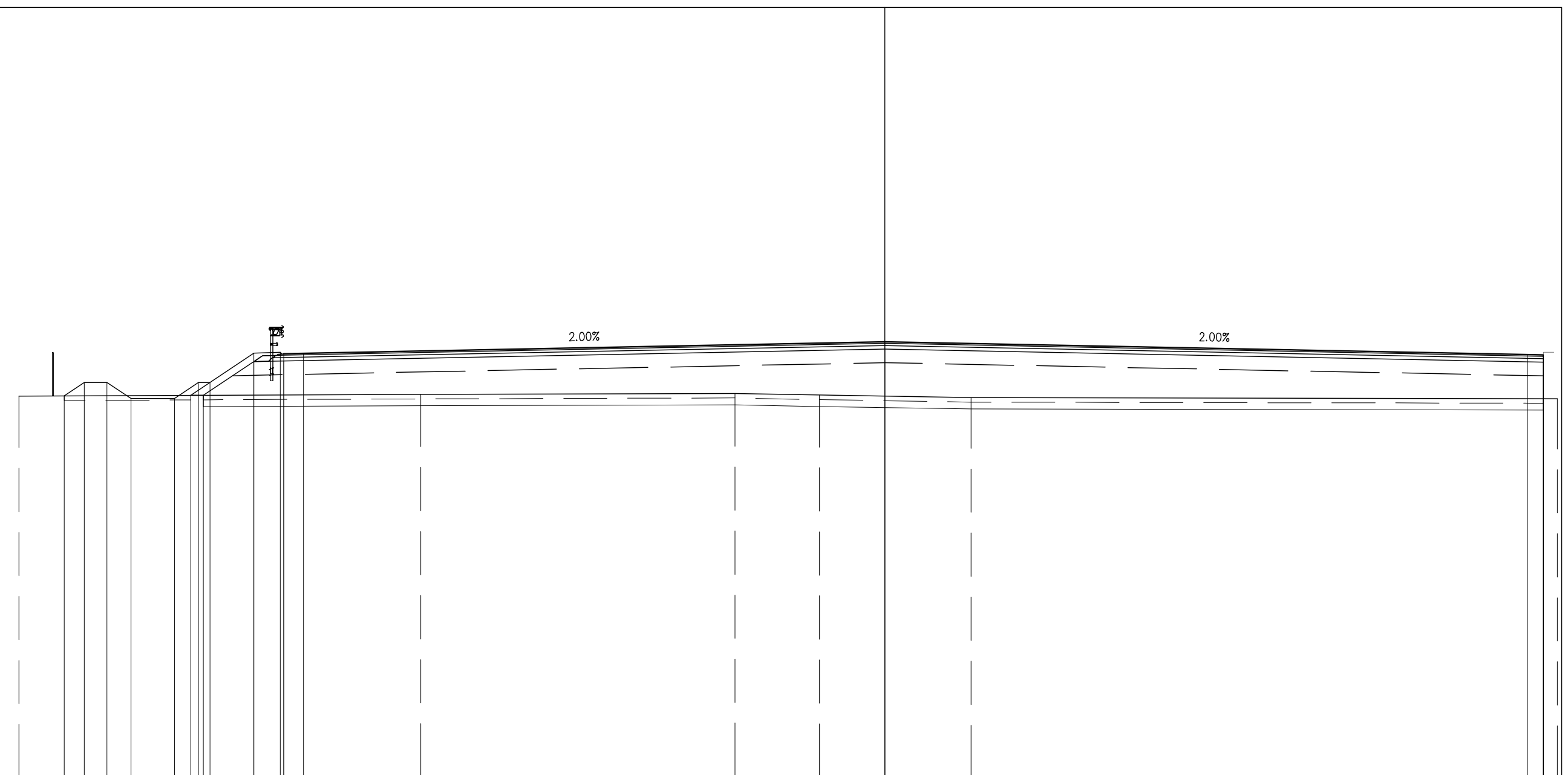

PROGRESSIVE TERRENO	-37.88		-20.30								29.41	
PARZIALI TERRENO	17.58		13.74		3.70	6.63				25.64		
QUOTE TERRENO	13.61							13.69	13.73	13.65	13.55	13.49
PROGRESSIVE PROGETTO		-35.90	-35.03	-34.03	-32.98	-31.08	-30.03	-29.53	-27.60	-26.45	-26.30	28.10
PARZIALI PROGETTO		0.87	1.00	1.05	1.90	1.05	0.90	1.93	25.43		0.00	28.10
QUOTE PROGETTO	13.62	14.20	14.20	13.50	13.50	14.20	14.20	15.48	15.53	15.47	15.49	15.44
PROGRESSIVE RILEVATO				-30.36	-29.82	-27.61	-26.30			0.00		28.80
PARZIALI RILEVATO				0.51	2.21		1.31	26.30			16.00	28.80
QUOTE RILEVATO				13.64	13.65	15.12	15.14			15.67		15.09

PROFILO SV-FINALE-SR
SEZIONE SR-9
PROGRESSIVA 200.00
BASE C1 5.55 mq. CEMENTATO CE1 8.35 mq. VEGETALE D2 1.05 mq. SOTTOFONDAZIONE STRADALE H1 34.13 mq. RILEVATO ARGINELLO RA1 0.17 mq. RILEVATO RI1 63.70 mq. SCAVO FOSSI SF1 2.07 mq. RILEVATO FOSSI VF1 2.88 mq. TAPPETO DRENANTE a1 55.13 ml. BINDER b1 55.40 ml. BONIFICA bo1 58.55 ml. INERBIMENTO i4 3.47 ml. SCOTICO sc2 58.55 ml. SCOTICO FOSSI sf1 5.53 ml.
$\nabla -3$ 200
PROGRESSIVE TERRENO
PARZIALI TERRENO
QUOTE TERRENO
PROGRESSIVE PROGETTO
PARZIALI PROGETTO
QUOTE PROGETTO
PROGRESSIVE RILEVATO
PARZIALI RILEVATO
QUOTE RILEVATO

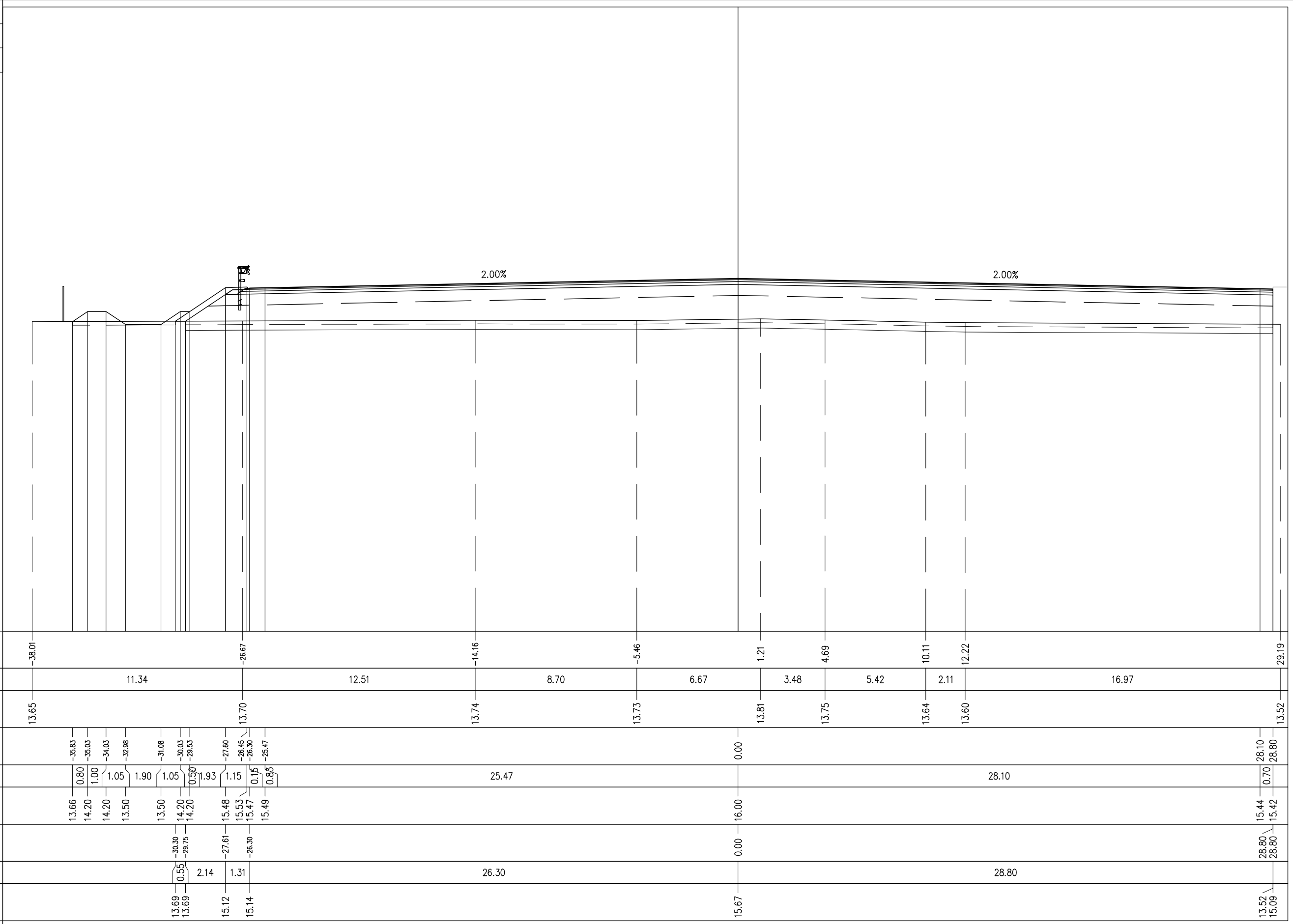

PROFILO SV-FINALE-SR
 SEZIONE SR-13
 PROGRESSIVA 268.42

- BASE
- C1 5.56 mq.
- CEMENTATO
- CE1 8.34 mq.
- VEGETALE
- D1 1.00 mq.
- SOTTOFONDAZIONE STRADALE
- H1 34.13 mq.
- RILEVATO ARGINELLO
- RA1 0.14 mq.
- RILEVATO
- RI1 50.64 mq.
- SCAVO FOSSI
- SF1 2.07 mq.
- RILEVATO FOSSI
- VF1 2.30 mq.
- TAPPETO DRENANTE
- a1 55.13 ml.
- BINDER
- b1 55.40 ml.
- BONIFICA
- bo1 58.37 ml.
- INERBIMENTO
- i4 3.32 ml.
- SCOTICO
- sc2 58.37 ml.
- SCOTICO FOSSI
- sf1 5.39 ml.

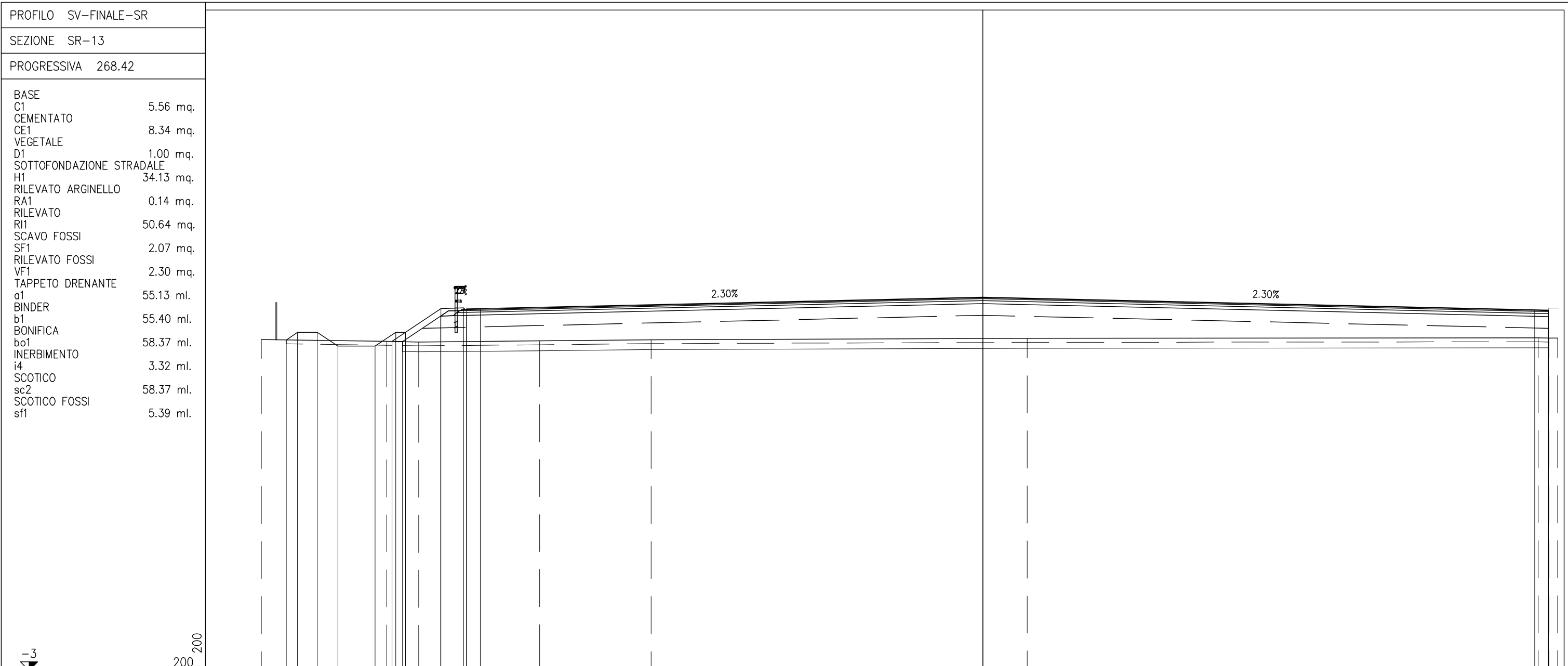

PROGRESSIVE TERRENO	-36.76			-30.36	-28.74		-22.58		-16.90		2.25			28.28	28.82	29.27
PARZIALI TERRENO		6.40		1.62		6.16		5.68		19.15		26.03		0.54	0.45	
QUOTE TERRENO	13.83			13.75	13.71		13.77		13.83		13.89			13.92	13.91	13.91
PROGRESSIVE PROGETTO		-35.48	-34.91	-33.91	-32.66	-30.96	-29.91	-29.41	-27.60	-26.45	-26.30	-25.60	0.00	28.10	28.80	
PARZIALI PROGETTO		0.57	1.00	1.05	1.90	1.05	0.50	0.81	1.15	0.15	0.70		25.60	28.10	0.70	
QUOTE PROGETTO	13.82	14.20	14.20	13.50	13.50	14.20	14.20	15.40	15.45	15.39	15.41		16.00	15.35	15.34	
PROGRESSIVE RILEVATO				-30.09	-29.57	-27.81	-26.30					0.00		28.80	28.80	
PARZIALI RILEVATO				0.52	1.96	1.31							26.30	28.80		
QUOTE RILEVATO				13.74	13.75	15.03	15.06					15.67		13.91	15.01	

PROFILO SV-FINALE-SR

SEZIONE SR-15

PROGRESSIVA 338.42

- BASE
- C1 1.14 mq.
- CEMENTATO
- CE1 1.74 mq.
- VEGETALE
- D1 0.33 mq.
- D2 1.09 mq.
- Totale: 1.42 mq.
- SOTTOFONDAZIONE STRADALE
- H1 8.44 mq.
- RILEVATO ARGINELLO
- RA1 0.16 mq.
- RA2 0.16 mq.
- Totale: 0.32 mq.
- RILEVATO
- R11 15.73 mq.
- SCAVO FOSSI
- SF1 2.07 mq.
- RILEVATO FOSSI
- VF1 1.28 mq.
- TAPPETO DRENANTE
- a1 10.56 ml.
- BINDER
- b1 11.10 ml.
- BONIFICA
- bo1 17.64 ml.
- INERBIMENTO
- i3 2.02 ml.
- i4 4.18 ml.
- Totale: 6.20 ml.
- SCOTICO
- sc2 17.64 ml.
- SCOTICO FOSSI
- sf1 5.52 ml.

-2
200
200

PROGRESSIVE TERRENO	-30.00	-11.73	8.32	30.00
PARZIALI TERRENO	18.27	20.05	21.68	
QUOTE TERRENO	13.92	13.97	14.03	14.10
PROGRESSIVE PROGETTO	-14.93	-10.62	-6.55	-3.75
PARZIALI PROGETTO	0.36	1.05	1.15	1.50
QUOTE PROGETTO	13.96	13.50	15.88	15.91
PROGRESSIVE RILEVATO	-9.41	-6.57	-5.25	0.00
PARZIALI RILEVATO	0.55	2.29	1.32	5.25
QUOTE RILEVATO	13.97	13.98	15.51	15.54

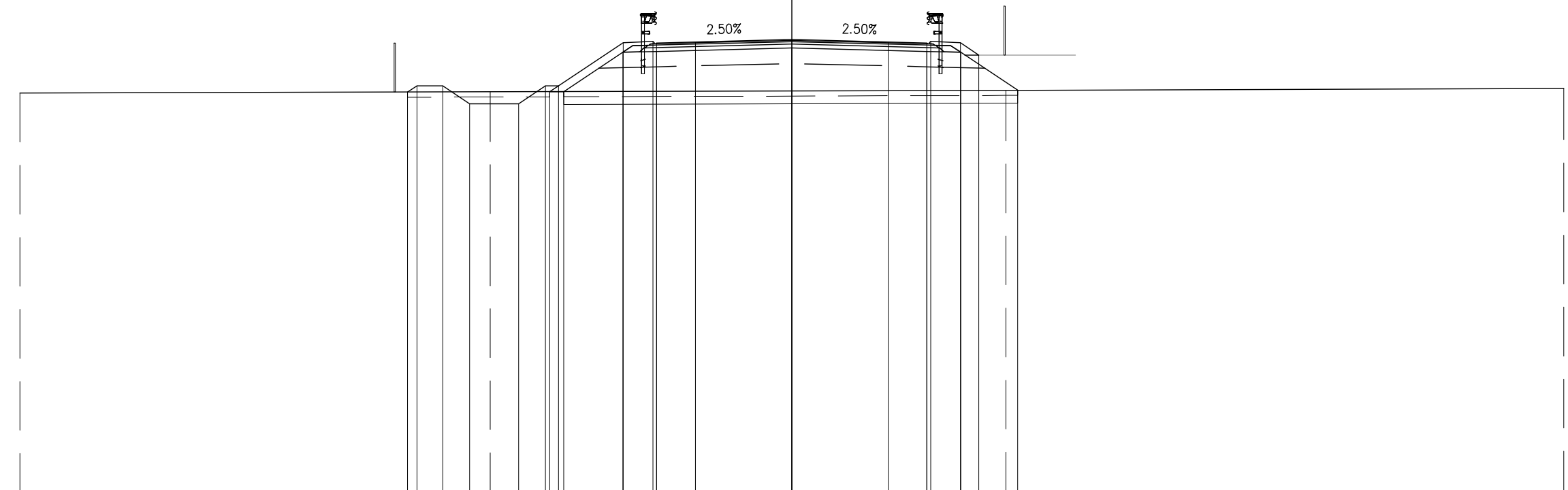

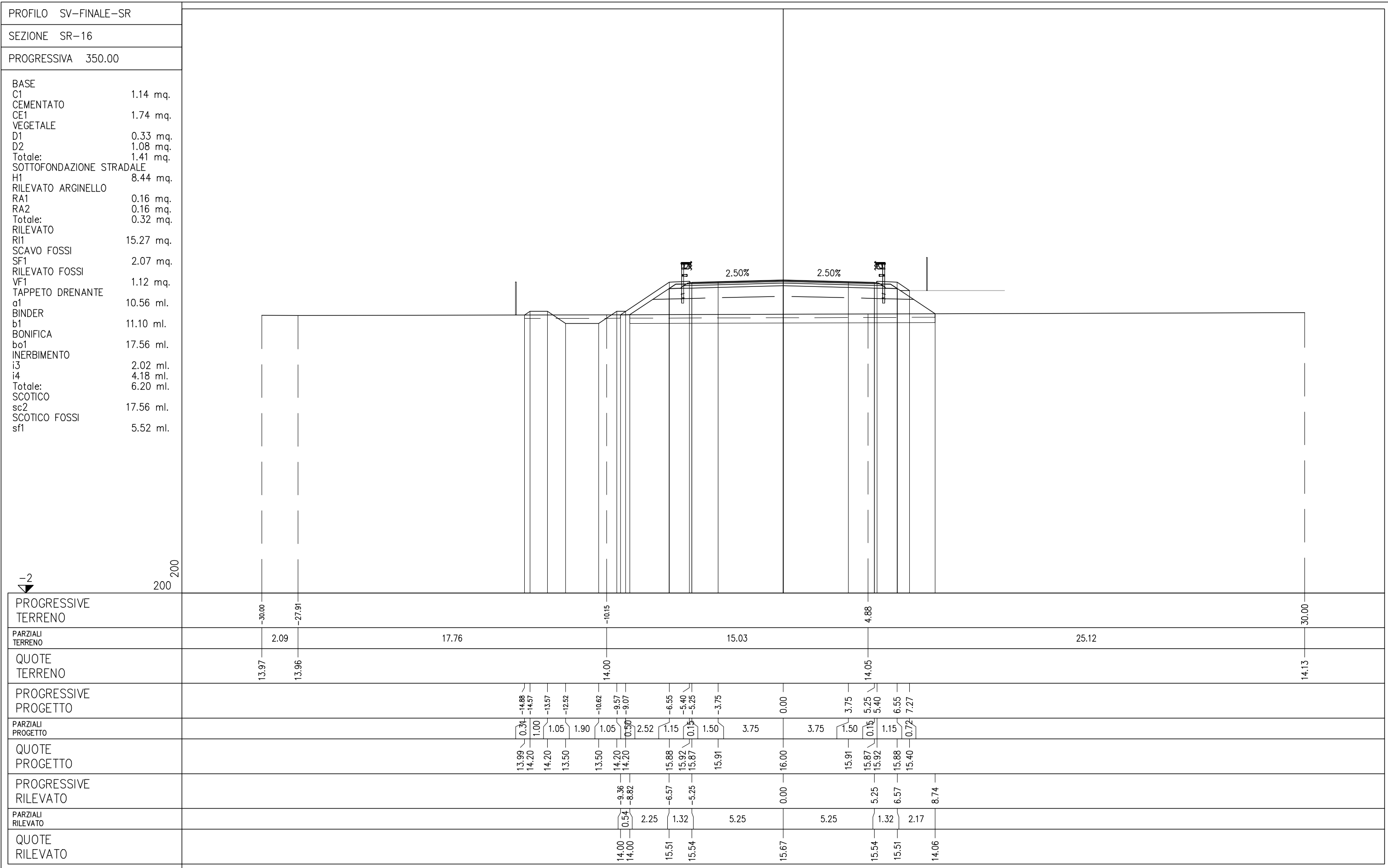

PROFILO SV-FINALE-SR

SEZIONE SR-17

PROGRESSIVA 375.00

- BASE
- C1 1.14 mq.
- CEMENTATO
- CE1 1.74 mq.
- VEGETALE
- D1 0.33 mq.
- D2 1.04 mq.
- Totale: 1.37 mq.
- SOTTOFONDAZIONE STRADALE
- H1 8.44 mq.
- RILEVATO ARGINELLO
- RA1 0.16 mq.
- RA2 0.16 mq.
- Totale: 0.32 mq.
- RILEVATO
- R11 14.23 mq.
- SCAVO FOSSI
- SF1 2.07 mq.
- RILEVATO FOSSI
- VF1 0.72 mq.
- TAPPETO DRENANTE
- a1 10.56 ml.
- BINDER
- b1 11.10 ml.
- BONIFICA
- bo1 17.37 ml.
- INERBIMENTO
- i3 2.02 ml.
- i4 4.18 ml.
- Totale: 6.20 ml.
- SCOTICO
- sc2 17.37 ml.
- SCOTICO FOSSI
- sf1 5.47 ml.

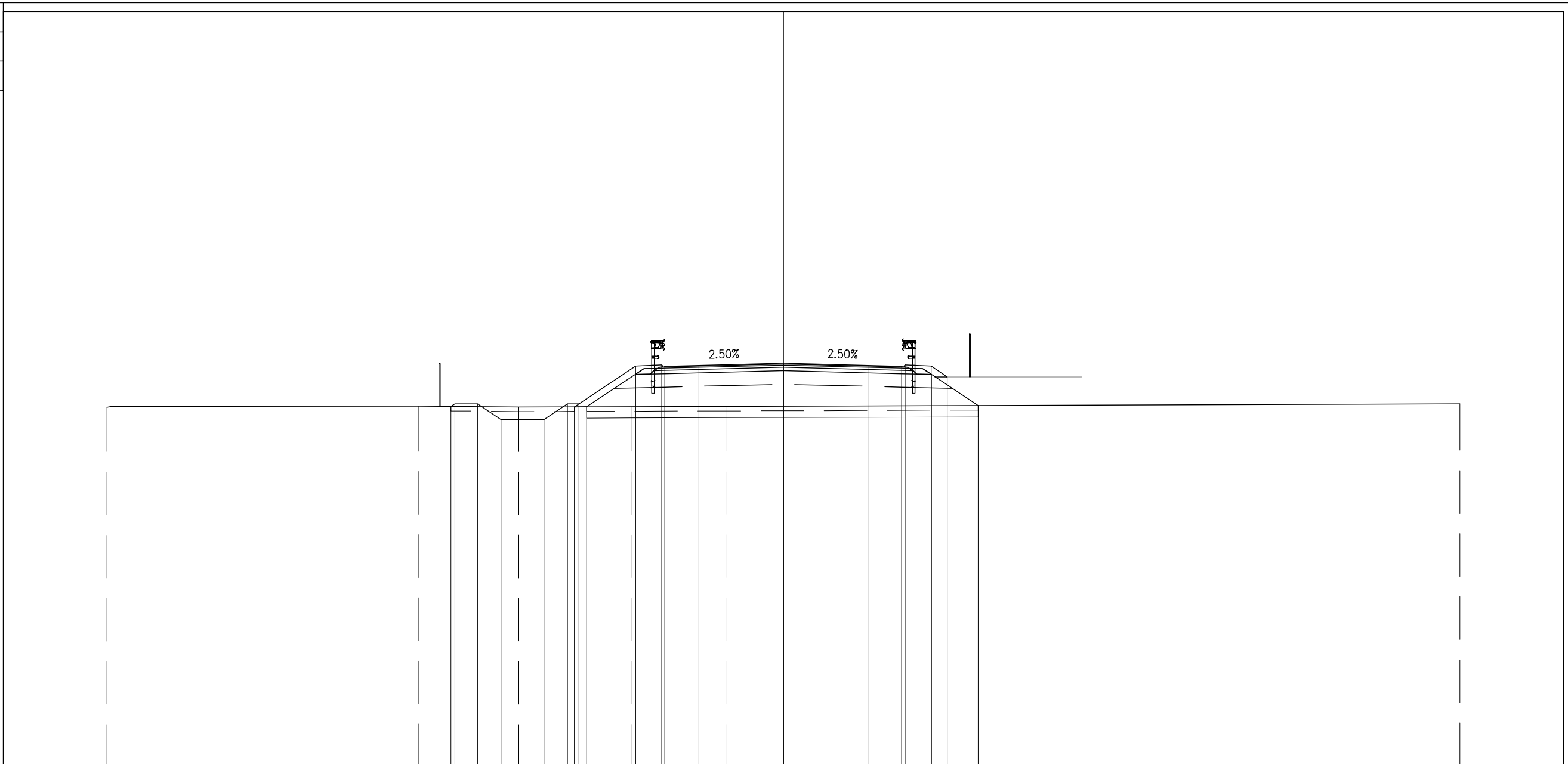

PROGRESSIVE TERRENO	-30.00	-16.17	-11.74	-6.76	-2.54	30.00												
PARZIALI TERRENO	13.83	4.43	4.98	4.22	32.54													
QUOTE TERRENO	14.05	14.10	14.06	14.07	14.08	14.19												
PROGRESSIVE PROGETTO		-14.74	-14.57	-13.57	-12.52	-10.62	-9.57	-9.07	-6.55	-5.40	-5.25	-3.75	0.00	3.75	5.25	5.40	6.55	7.27
PARZIALI PROGETTO		0.17	1.00	1.05	1.90	1.05	0.50	2.52	1.15	0.15	1.50	3.75	3.75	1.50	0.15	1.15	0.72	7.27
QUOTE PROGETTO		14.08	14.20	14.20	13.50	13.50	14.20	14.20	15.88	15.92	15.87	15.91	16.00	15.91	15.87	15.92	15.88	15.40
PROGRESSIVE RILEVATO				-9.27	-8.73	-6.57	-5.25	0.00	5.25	6.57	8.64							
PARZIALI RILEVATO				0.54	2.16	1.32	5.25	5.25	1.32	2.07								
QUOTE RILEVATO				14.07	14.07	15.51	15.54	15.67	15.54	15.51	14.12							

PROFILO SV-FINALE-SR

SEZIONE SR-18

PROGRESSIVA 400.00

- BASE
- C1 1.15 mq.
- CEMENTATO
- CE1 1.77 mq.
- VEGETALE
- D1 0.33 mq.
- D2 1.05 mq.
- Totale: 1.38 mq.
- SOTTOFONDAZIONE STRADALE
- H1 8.53 mq.
- RILEVATO ARGINELLO
- RA1 0.16 mq.
- RA2 0.16 mq.
- Totale: 0.32 mq.
- RILEVATO
- R11 13.34 mq.
- SCAVO FOSSI
- SF1 2.07 mq.
- RILEVATO FOSSI
- VF1 0.50 mq.
- TAPPETO DRENANTE
- a1 10.71 ml.
- BINDER
- b1 11.25 ml.
- BONIFICA
- bo1 17.34 ml.
- INERBIMENTO
- i3 2.02 ml.
- i4 4.17 ml.
- Totale: 6.19 ml.
- SCOTICO
- sc2 17.34 ml.
- SCOTICO FOSSI
- sf1 5.53 ml.

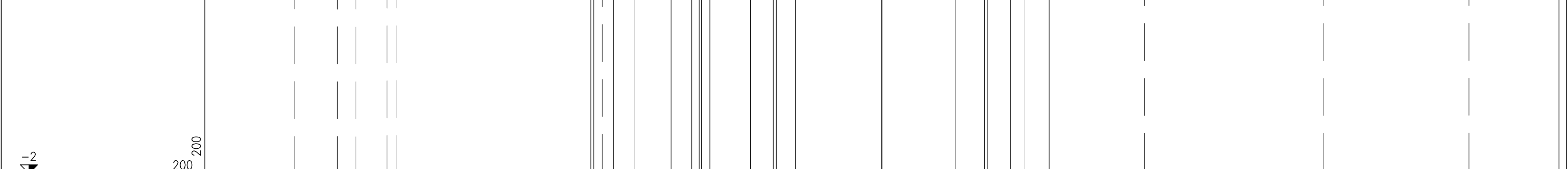

PROGRESSIVE TERRENO	-30.00	-27.82	-26.87	-25.28	-24.78	-14.29	-14.29	0.00	13.43	22.59	30.00											
PARZIALI TERRENO	2.18	0.95	1.59	0.50	10.49	27.72	9.16	7.41														
QUOTE TERRENO	13.89	13.87	13.85	13.97	13.98	14.10	14.20	14.20	14.20	14.20	14.23											
PROGRESSIVE PROGETTO						-14.87	-14.71	-13.71	-12.66	-10.76	-9.71	-9.21	-6.70	-5.55	-5.40	-4.40	0.00	3.75	5.25	5.40	6.55	7.27
PARZIALI PROGETTO						0.16	1.00	1.05	1.90	1.05	0.50	2.51	1.15	0.15	1.00	4.40	3.75	1.50	0.15	1.15	0.72	
QUOTE PROGETTO						14.09	14.20	14.20	13.50	13.50	14.20	14.20	15.88	15.92	15.87	15.89	16.00	15.91	15.87	15.92	15.88	15.40
PROGRESSIVE RILEVATO											-9.34	-8.79	-6.72	-5.40	0.00	0.00	5.25	6.57	8.55			
PARZIALI RILEVATO											0.55	2.07	1.32	5.40	5.25	1.32	1.98					
QUOTE RILEVATO											14.12	14.12	15.50	15.54	15.67	15.54	15.51	14.18				

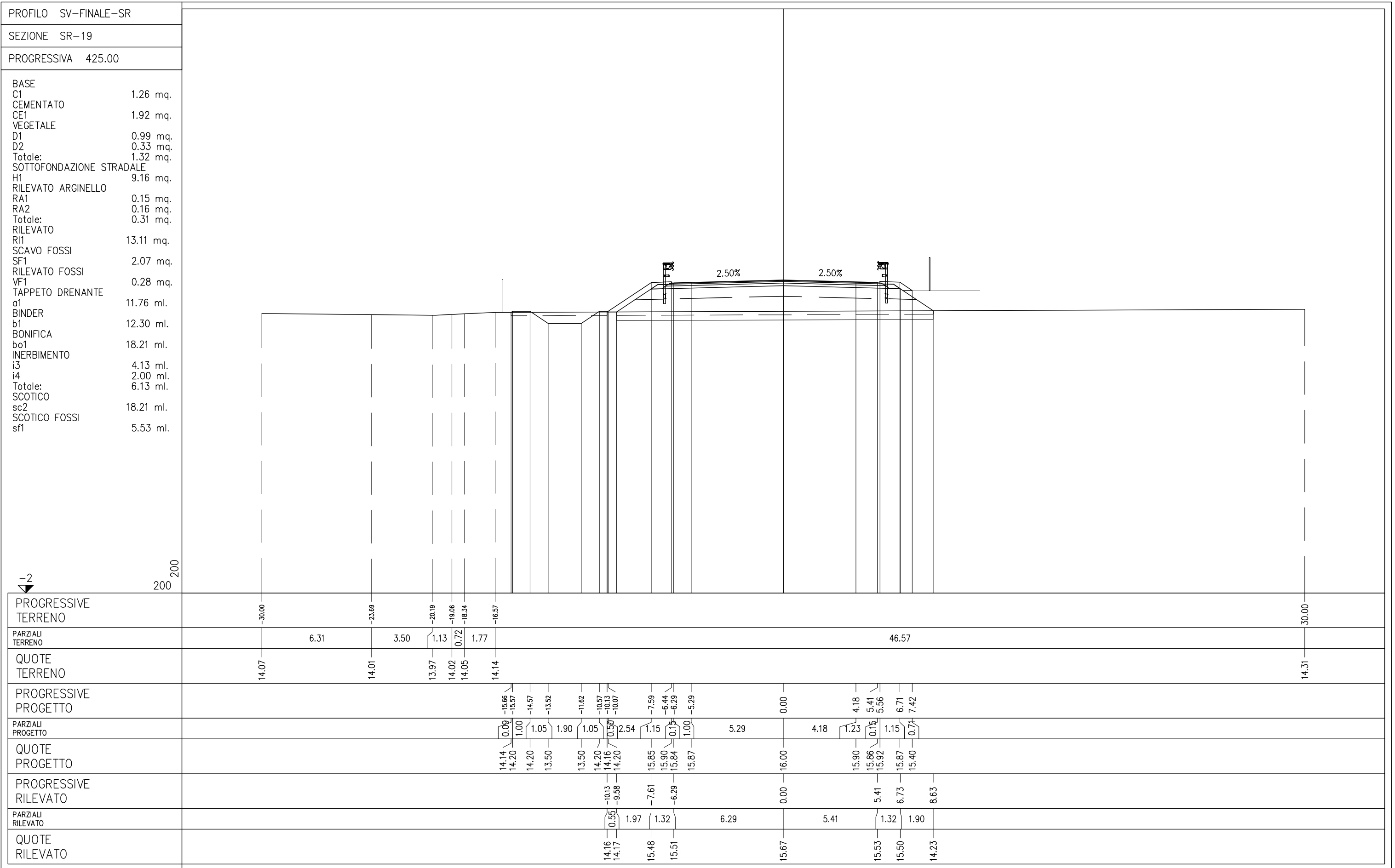

PROFILO SV-FINALE-SR

SEZIONE SR-20

PROGRESSIVA 449.50

- BASE
- C1 2.60 mq.
- CEMENTATO
- CE1 3.94 mq.
- VEGETALE
- D1 0.97 mq.
- D2 0.30 mq.
- Totale: 1.27 mq.
- SOTTOFONDAZIONE STRADALE
- H1 17.26 mq.
- RILEVATO ARGINELLO
- RA1 0.15 mq.
- RA2 0.15 mq.
- Totale: 0.30 mq.
- RILEVATO
- R11 20.21 mq.
- SCAVO FOSSI
- SF1 2.07 mq.
- RILEVATO FOSSI
- VF1 0.71 mq.
- TAPPETO DRENANTE
- a1 25.22 ml.
- BINDER
- b1 25.76 ml.
- BONIFICA
- bo1 31.12 ml.
- INERBIMENTO
- i3 3.83 ml.
- i4 1.71 ml.
- Totale: 5.54 ml.
- SCOTICO
- sc2 31.12 ml.
- SCOTICO FOSSI
- sf1 5.44 ml.

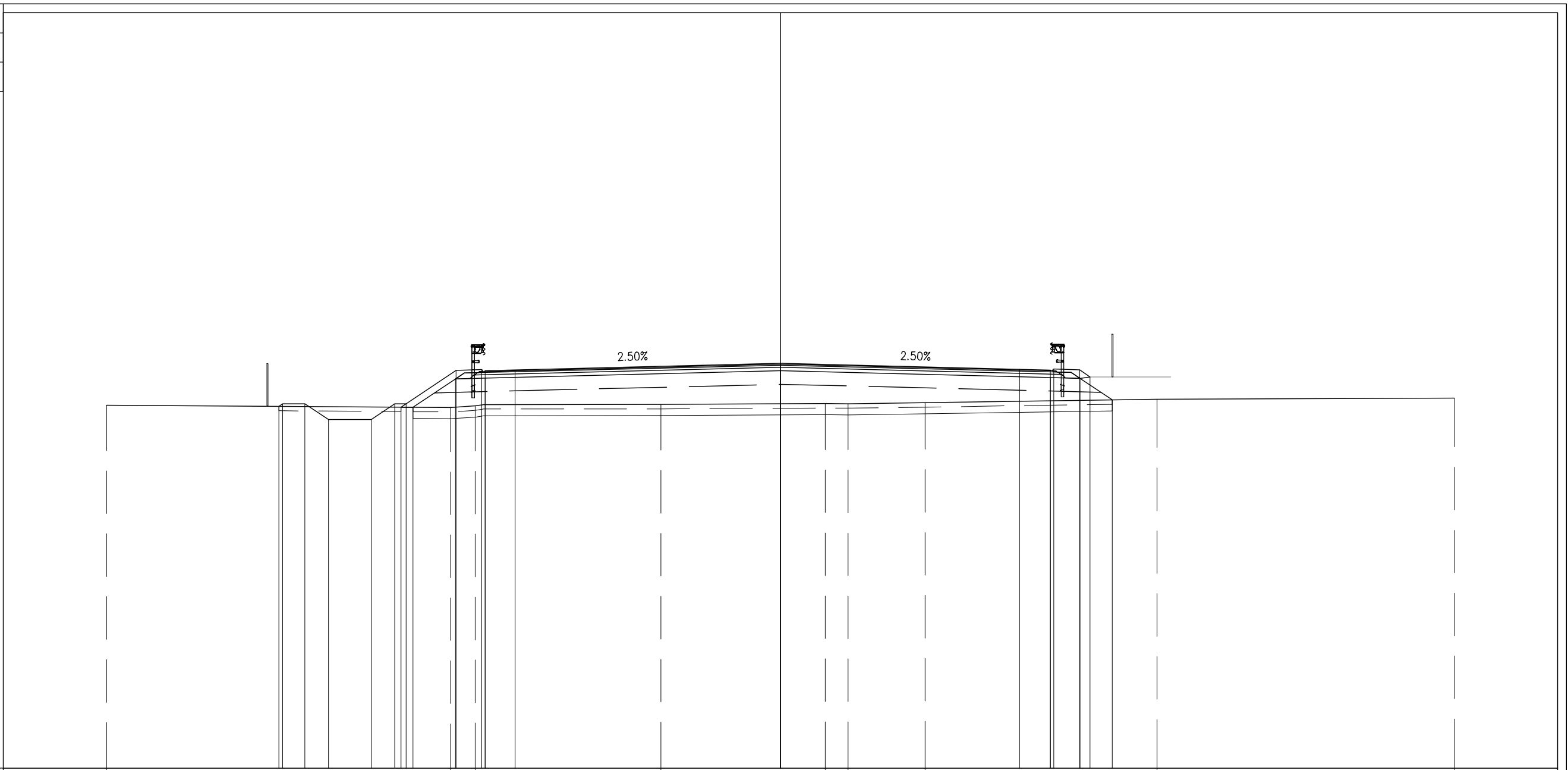

PROGRESSIVE TERRENO	-30.00																				30.00	
PARZIALI TERRENO	15.32					1.09		8.27		7.32		1.01		3.43		10.32			13.24			
QUOTE TERRENO	14.14					14.04				14.18			14.21	14.21	14.25			14.41		14.46		
PROGRESSIVE PROGETTO		-22.33	-22.17	-21.17	-20.12	-18.22	-17.17	-16.89	-16.67		-14.44	-13.29	-13.14	-11.81								
PARZIALI PROGETTO	0.16		1.00	1.05	1.90	1.05	0.50	2.45	1.15	11.81			10.65			1.37			10.65	12.02		12.17
QUOTE PROGETTO	14.09	14.20	14.20	13.50	13.50	14.20	14.05	14.20	15.68	15.73	15.67	15.70		16.00				15.73	15.70	15.76	15.71	15.40
PROGRESSIVE RILEVATO						-16.89	-16.35	-14.46	-13.14		0.00											
PARZIALI RILEVATO	0.54		1.89		1.32		13.14			12.02			1.32		1.43		14.77					
QUOTE RILEVATO	14.05	14.05			15.31	15.34			15.67					15.37	15.34	14.38						

SVINCOLO DI SAN FELICE SUL PANARO - FINALE EMILIA
ROTATORIA
SAT03

PROFILO SV-FINALE-RO

SEZIONE RO-1

PROGRESSIVA 0.00

- BASE
- C1 0.80 mq.
- SOTTOFONDAZIONE STRADALE
- H1 5.39 mq.
- RILEVATO
- RI1 9.73 mq.
- RIEMPIMENTO
- RP1 72.04 mq.
- VEGETALE AIUOLA
- VA1 9.62 mq.
- TAPPETO DRENANTE
- a1 8.00 ml.
- BINDER
- b1 8.00 ml.
- BONIFICA
- bo1 10.84 ml.
- INERBIMENTO
- i1 32.15 ml.
- SCOTICO
- sc1 10.84 ml.

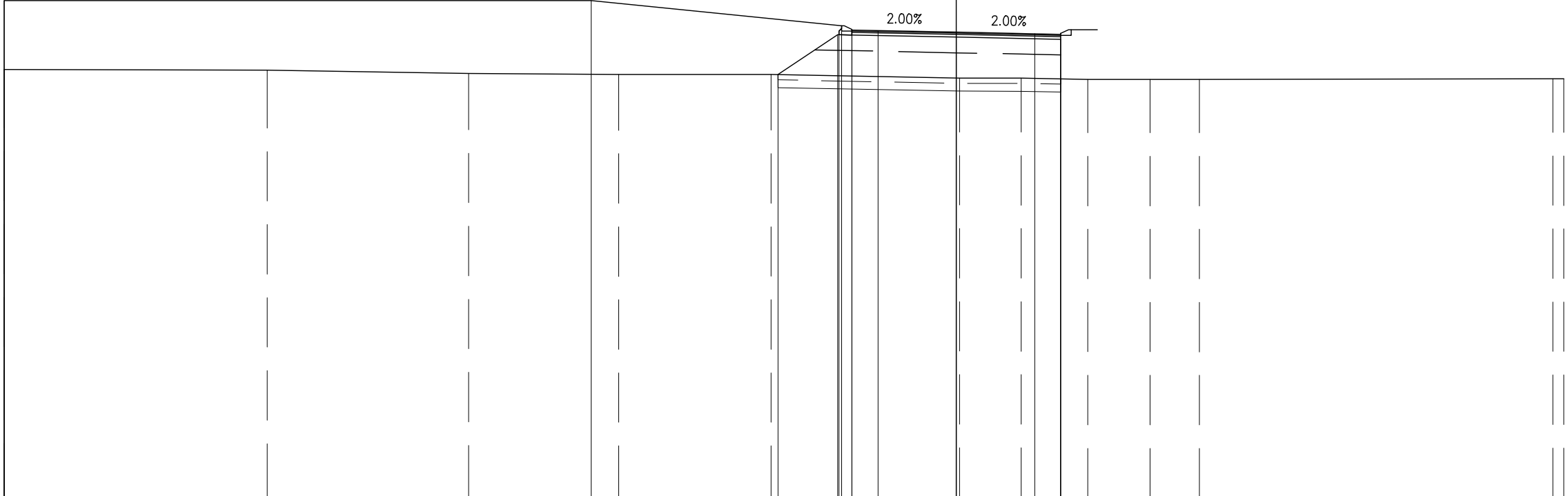

PROGRESSIVE TERRENO	-36.50	-26.42	-18.70	-12.95	-7.10	0.12	2.48	5.03	7.42	9.32	22.87	23.29
PARZIALI TERRENO	10.08	7.72	5.75	5.85	7.22	2.36	2.55	2.39	1.90	13.55	0.42	0.42
QUOTE TERRENO	14.57	14.55	14.41	14.37	14.38	14.24	14.23	14.18	14.18	14.18	14.21	14.21
PROGRESSIVE PROGETTO	-36.50	-36.50	-14.00	-4.40	-4.00	-3.00	0.00	3.00	4.00			
PARZIALI PROGETTO	22.50	9.60	0.40	1.00	3.00	3.00	1.00	4.00				
QUOTE PROGETTO	17.21	14.57	17.21	16.25	16.08	16.06	16.00	15.94	15.92			
PROGRESSIVE RILEVATO					-6.84	-4.55	-4.50	-4.00	0.00	4.00	4.00	
PARZIALI RILEVATO					2.29	0.06	0.50	4.00	4.00			
QUOTE RILEVATO					14.37	15.90	15.90	15.89	15.81	14.20	15.73	

PROFILO SV-FINALE-RO

SEZIONE RO-2

PROGRESSIVA 4.33

- BASE
- C1 0.80 mq.
- SOTTOFONDAZIONE STRADALE
- H1 5.39 mq.
- RILEVATO
- RI1 9.19 mq.
- RIEMPIMENTO
- RP1 72.04 mq.
- VEGETALE AIUOLA
- VA1 9.63 mq.
- TAPPETO DRENANTE
- a1 8.00 ml.
- BINDER
- b1 8.00 ml.
- BONIFICA
- bo1 10.82 ml.
- INERBIMENTO
- i1 32.15 ml.
- SCOTICO
- sc1 10.82 ml.

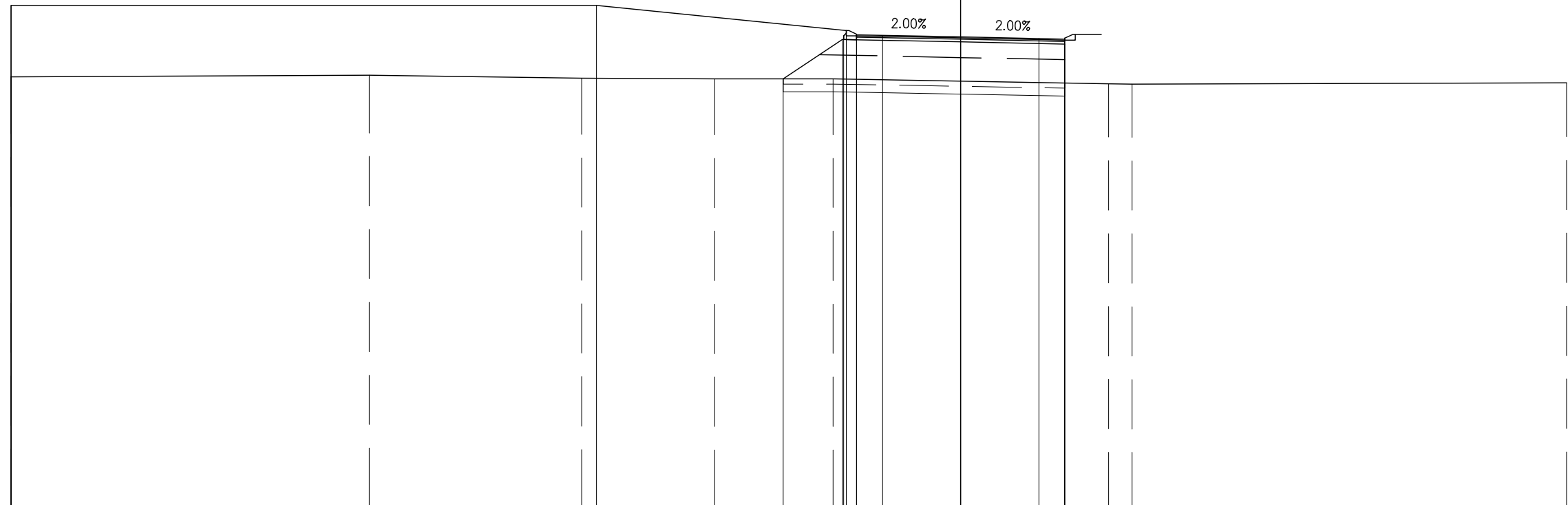

PROGRESSIVE TERRENO	-36.50	-22.74	-14.58	-9.45	-4.91	5.69	6.58	23.29
PARZIALI TERRENO	13.76	8.16	5.13	4.54	10.60	0.89	16.71	
QUOTE TERRENO	14.47	14.53	14.42	14.39	14.39	14.21	14.19	14.23
PROGRESSIVE PROGETTO	-36.50	-36.50	-14.00		-4.40	0.00	3.00	4.00
PARZIALI PROGETTO	22.50		9.60		0.40	3.00	3.00	1.00
QUOTE PROGETTO	17.21	14.47	17.21		16.25	16.00	15.94	15.92
PROGRESSIVE RILEVATO					-6.82	0.00	4.00	4.00
PARZIALI RILEVATO					2.27	4.00	4.00	
QUOTE RILEVATO					14.39	15.81	14.24	15.73

PROFILO SV-FINALE-RO

SEZIONE RO-3

PROGRESSIVA 25.07

- BASE
- C1 0.80 mq.
- SOTTOFONDAZIONE STRADALE
- H1 5.39 mq.
- RILEVATO
- RI1 7.18 mq.
- RIEMPIMENTO
- RP1 69.19 mq.
- VEGETALE AIUOLA
- VA1 9.63 mq.
- TAPPETO DRENANTE
- a1 8.00 ml.
- BINDER
- b1 8.00 ml.
- BONIFICA
- bo1 10.62 ml.
- INERBIMENTO
- i2 32.15 ml.
- SCOTICO
- sc1 10.62 ml.

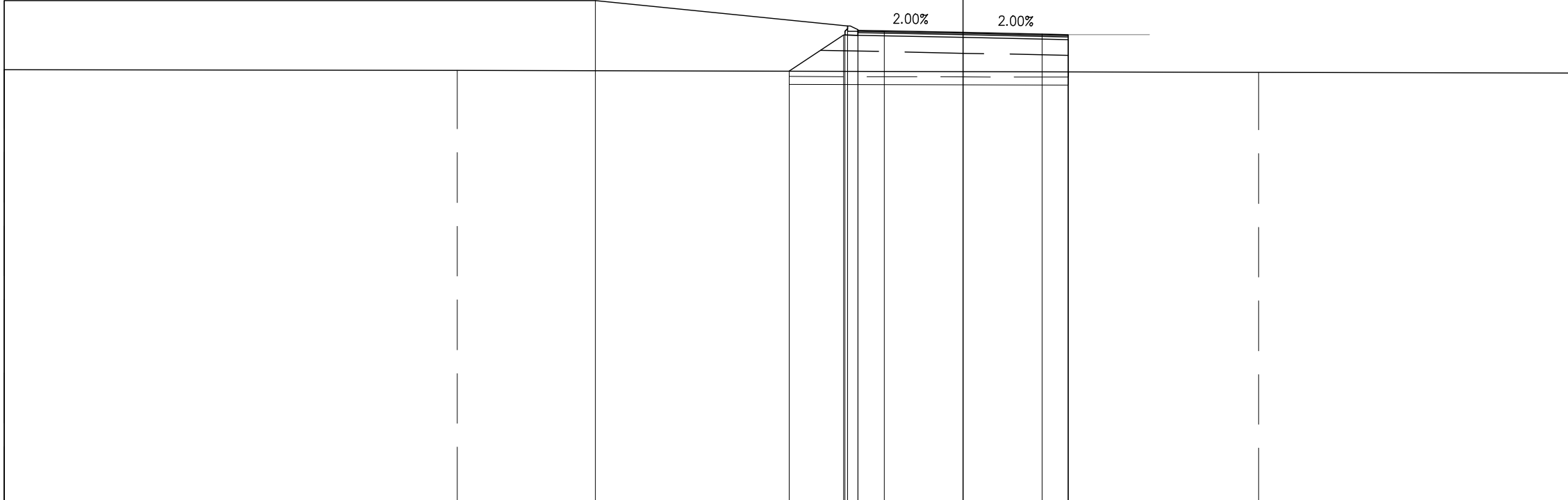

PROGRESSIVE TERRENO	-36.50	-19.26								11.24	23.29
PARZIALI TERRENO		17.24			30.50					12.05	
QUOTE TERRENO	14.59	14.56								14.48	14.46
PROGRESSIVE PROGETTO	-36.50	-36.50	-14.00		-4.40	-4.00	-3.00	0.00	3.00	4.00	
PARZIALI PROGETTO		22.50		9.60		1.00	3.00	3.00	1.00	4.00	
QUOTE PROGETTO	17.21	14.59	17.21		16.25	16.08	16.06	16.00	15.94	15.92	
PROGRESSIVE RILEVATO					-6.62	-4.55	-4.50	-4.00	0.00	4.00	4.00
PARZIALI RILEVATO					2.07	0.05	0.50	4.00	4.00		
QUOTE RILEVATO					14.53	15.90	15.90	15.89	15.81	14.50	15.73

PROFILO SV-FINALE-RO

SEZIONE RO-4

PROGRESSIVA 54.15

- BASE
- C1 0.80 mq.
- SOTTOFONDAZIONE STRADALE
- H1 5.39 mq.
- RILEVATO
- RI1 5.17 mq.
- RIEMPIMENTO
- RP1 66.59 mq.
- VEGETALE AIUOLA
- VA1 9.62 mq.
- TAPPETO DRENANTE
- a1 8.00 ml.
- BINDER
- b1 8.00 ml.
- BONIFICA
- bo1 10.36 ml.
- INERBIMENTO
- i1 32.15 ml.
- SCOTICO
- sc1 10.36 ml.

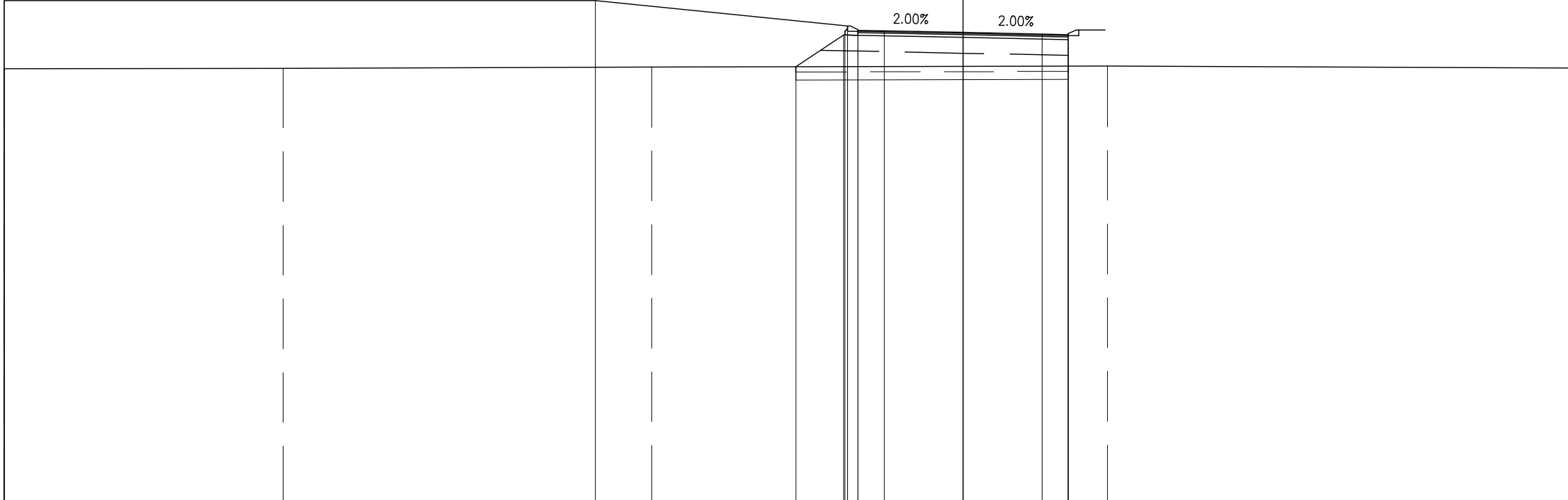

PROGRESSIVE TERRENO	-36.50	-25.89	-11.85	5.49	23.29					
PARZIALI TERRENO	10.61	14.04	17.34	17.80						
QUOTE TERRENO	14.62	14.63	14.68	14.72	14.65					
PROGRESSIVE PROGETTO	-36.50	-36.50	-14.00	-4.40	-4.00	-3.00	0.00	3.00	4.00	
PARZIALI PROGETTO	22.50	9.60	3.00	3.00	1.00	4.00				
QUOTE PROGETTO	17.21	14.62	17.21	16.25	16.08	16.06	16.00	15.94	15.92	
PROGRESSIVE RILEVATO				-6.36	-4.55	-4.50	-4.00	0.00	4.00	4.00
PARZIALI RILEVATO				1.81	0.05	0.50	4.00	4.00		
QUOTE RILEVATO				14.69	15.90	15.90	15.89	15.81	14.72	15.73

-2
200 200

PROFILO SV-FINALE-RO

SEZIONE RO-5

PROGRESSIVA 85.54

- BASE
- C1 0.80 mq.
- SOTTOFONDAZIONE STRADALE
- H1 5.39 mq.
- RILEVATO
- RI1 3.79 mq.
- RIEMPIMENTO
- RP1 64.53 mq.
- VEGETALE AIUOLA
- VA1 9.62 mq.
- TAPPETO DRENANTE
- a1 8.00 ml.
- BINDER
- b1 8.00 ml.
- BONIFICA
- bo1 10.19 ml.
- INERBIMENTO
- i1 32.15 ml.
- SCOTICO
- sc1 10.19 ml.

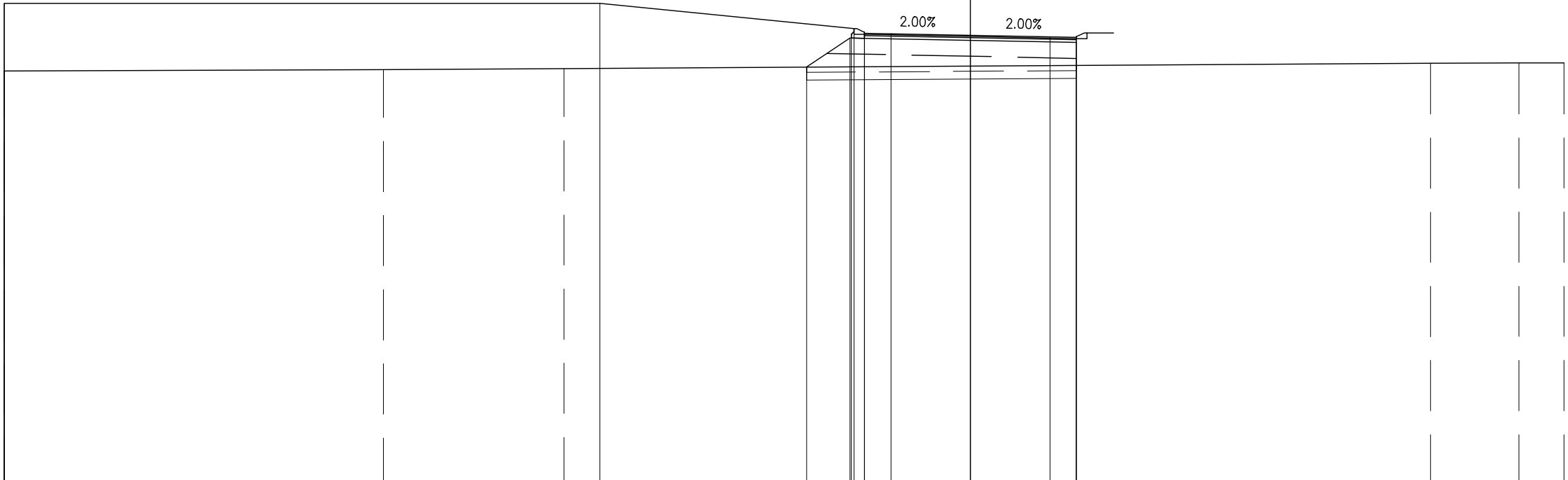

-1
200
200

PROGRESSIVE TERRENO	-36.50	-22.18	-15.37							17.38	20.72	22.42
PARZIALI TERRENO		14.32	6.81			32.75				3.34	1.70	
QUOTE TERRENO	14.65	14.70	14.75							14.95	14.96	14.96
PROGRESSIVE PROGETTO	-36.50 -36.50			-14.00			-4.40 -4.00	-3.00	0.00	3.00	4.00	
PARZIALI PROGETTO		22.50			9.60		0.40 1.00	3.00	3.00	1.00	4.00	
QUOTE PROGETTO	14.65 17.21			17.21			16.25 16.08	16.06	16.00	15.94	15.92	
PROGRESSIVE RILEVATO							-6.19 -4.55 -4.50 -4.00		0.00	4.00	4.00	
PARZIALI RILEVATO							1.64 0.05 0.50	4.00		4.00		
QUOTE RILEVATO							14.81 15.90 15.90 15.89		15.81	14.87 15.73		

PROFILO SV-FINALE-RO

SEZIONE RO-6

PROGRESSIVA 89.32

- BASE
- C1 0.80 mq.
- SOTTOFONDAZIONE STRADALE
- H1 5.39 mq.
- RILEVATO
- RI1 3.74 mq.
- RIEMPIMENTO
- RP1 64.39 mq.
- VEGETALE AIUOLA
- VA1 9.62 mq.
- TAPPETO DRENANTE
- a1 8.00 ml.
- BINDER
- b1 8.00 ml.
- BONIFICA
- bo1 10.18 ml.
- INERBIMENTO
- i1 32.15 ml.
- SCOTICO
- sc1 10.18 ml.

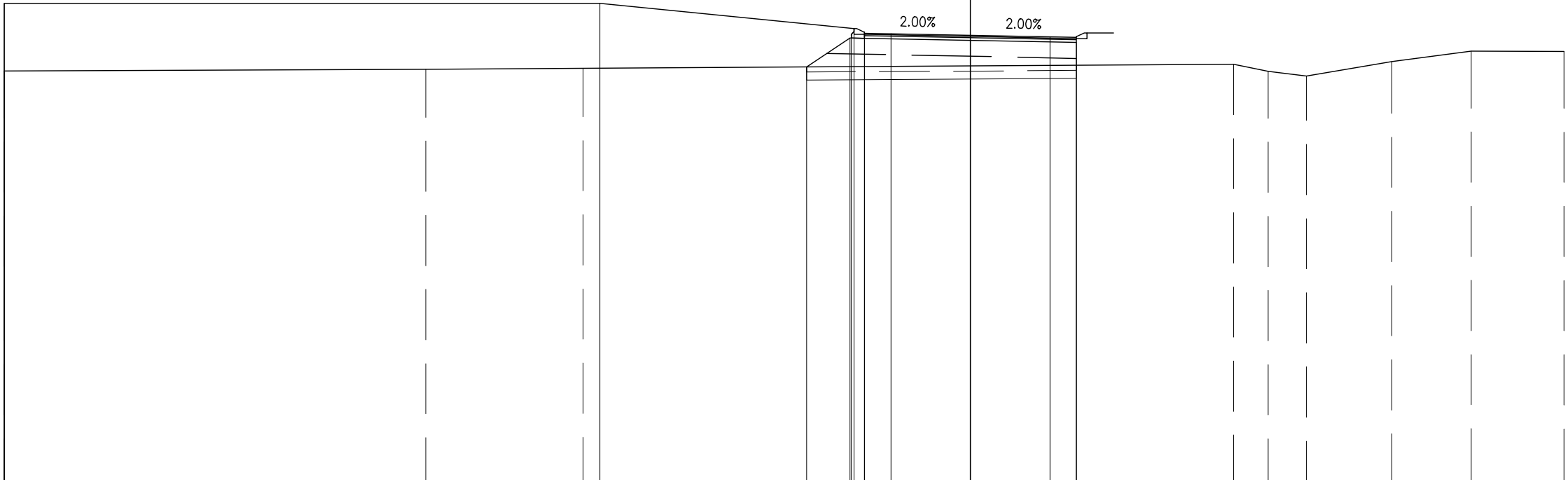

200
200
-1

PROGRESSIVE TERRENO	-36.50	-20.58	-14.64				9.95	11.25	12.69	15.92	18.92	22.42
PARZIALI TERRENO		15.92	5.94		24.59		1.30	1.44	3.23	3.00	3.50	
QUOTE TERRENO	14.66	14.71	14.76				14.91	14.64	14.47	15.02	15.40	15.39
PROGRESSIVE PROGETTO	-36.50	-36.50	-14.00							3.00	4.00	
PARZIALI PROGETTO		22.50		9.60		3.00	3.00	1.00	4.00			
QUOTE PROGETTO	17.21	14.66	17.21			16.00	15.94	15.92				
PROGRESSIVE RILEVATO										4.00	4.00	
PARZIALI RILEVATO						4.00	4.00					
QUOTE RILEVATO						14.81	15.90	15.89	15.81	14.88	15.73	

PROFILO SV-FINALE-RO

SEZIONE RO-7

PROGRESSIVA 90.89

- BASE
- C1 0.80 mq.
- SOTTOFONDAZIONE STRADALE
- H1 5.39 mq.
- RILEVATO
- RI1 3.74 mq.
- RIEMPIMENTO
- RP1 64.35 mq.
- VEGETALE AIUOLA
- VA1 9.62 mq.
- TAPPETO DRENANTE
- a1 8.00 ml.
- BINDER
- b1 8.00 ml.
- BONIFICA
- bo1 10.18 ml.
- INERBIMENTO
- i1 32.15 ml.
- SCOTICO
- sc1 10.18 ml.

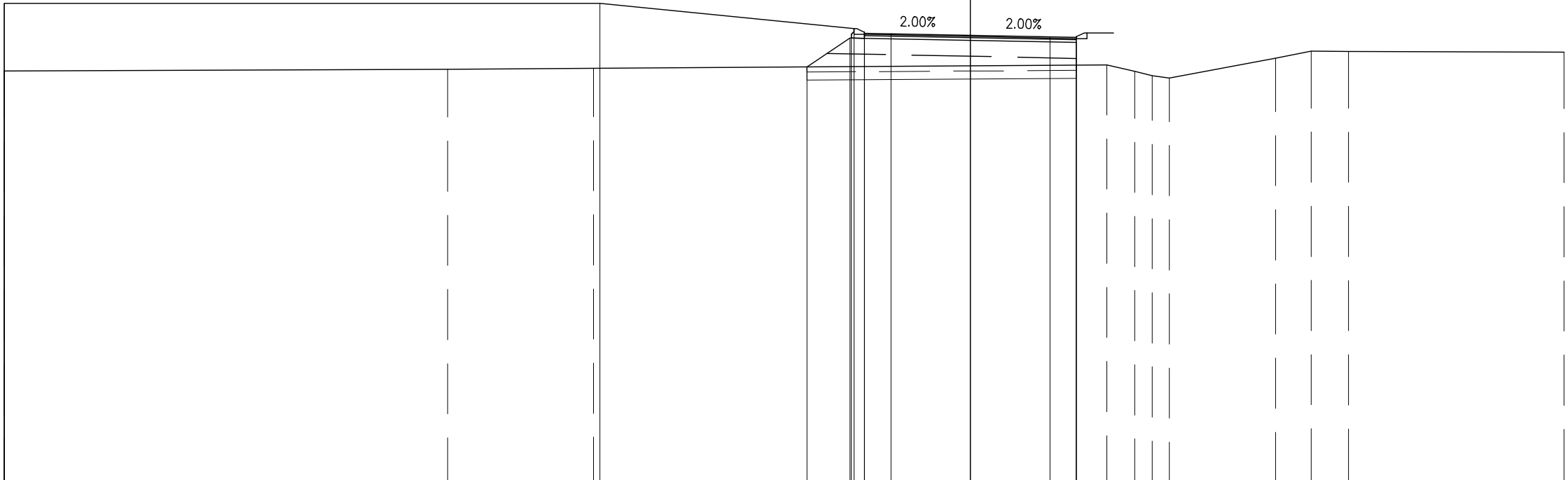

PROGRESSIVE TERRENO	-36.50	-19.75	-14.25	5.15	6.21	6.86	7.51	11.53	12.87	14.29	22.42
PARZIALI TERRENO	16.75	5.50	19.40	1.06	0.65	0.65	4.02	1.34	1.42	8.13	
QUOTE TERRENO	14.66	14.72	14.76	14.89	14.64	14.47	14.38	15.14	15.40	15.39	15.37
PROGRESSIVE PROGETTO	-36.50	-36.50	-14.00	-4.40	-4.00	-3.00	0.00	3.00	4.00		
PARZIALI PROGETTO	22.50	9.60	3.00	3.00	1.00	4.00					
QUOTE PROGETTO	17.21	14.66	17.21	16.25	16.08	16.06	16.00	15.94	15.92		
PROGRESSIVE RILEVATO				-6.18	-4.55	-4.50	-4.00	0.00	4.00	4.00	
PARZIALI RILEVATO				1.63	0.05	0.50	4.00	4.00			
QUOTE RILEVATO				14.81	15.90	15.90	15.89	15.81	14.88	15.73	

PROFILO SV-FINALE-RO

SEZIONE RO-8

PROGRESSIVA 112.07

- BASE
- C1 0.80 mq.
- SOTTOFONDAZIONE STRADALE
- H1 5.39 mq.
- RILEVATO
- RI1 7.90 mq.
- RIEMPIMENTO
- RP1 62.05 mq.
- VEGETALE AIUOLA
- VA1 9.62 mq.
- TAPPETO DRENANTE
- a1 8.00 ml.
- BINDER
- b1 8.00 ml.
- BONIFICA
- bo1 9.54 ml.
- INERBIMENTO
- i1 32.15 ml.
- SCOTICO
- sc1 9.54 ml.

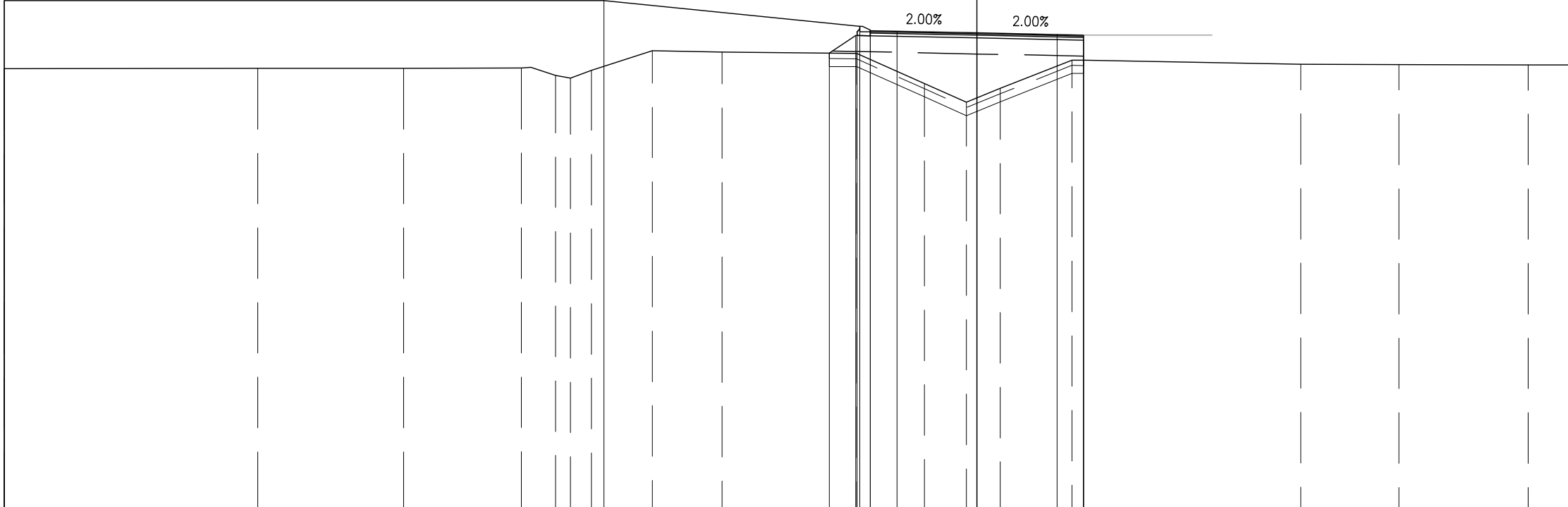

PROGRESSIVE TERRENO	-36.50	-26.99	-21.51	-17.10	-15.81	-15.26	-14.46	-12.19	-9.57	-4.52	-1.97	-0.40	0.87	3.56	12.15	15.84	20.68	22.42
PARZIALI TERRENO		9.51	5.48	4.41	1.29	0.55	0.80	2.27	2.62	5.05	2.55	1.57	1.27	2.69	8.59	3.69	4.84	1.74
QUOTE TERRENO	14.65	14.67	14.67	14.68	14.40	14.30	14.59	15.33	15.28	15.23	14.10	13.40	13.92	14.98	14.83	14.81	14.80	14.80
PROGRESSIVE PROGETTO	-36.50	-36.50	-14.00	-4.40	-4.00	-3.00	0.00	3.00	3.00	3.00	0.00	3.00	4.00	4.00				
PARZIALI PROGETTO		22.50	9.60	1.00	0.40	1.00	3.00	3.00	1.00	0.40	1.00	1.00	1.00	1.00				
QUOTE PROGETTO	14.65	17.21	17.21	16.25	16.08	16.06	16.00	15.94	15.92	16.25	16.06	16.00	15.94	15.92				
PROGRESSIVE RILEVATO										-5.54	-4.55	-4.50	-4.00	0.00	4.00	4.00		
PARZIALI RILEVATO										0.99	0.05	0.50	4.00	4.00				
QUOTE RILEVATO										15.24	15.90	15.90	15.89	15.81	14.98	15.73		

PROFILO SV-FINALE-RO

SEZIONE RO-9

PROGRESSIVA 146.27

- BASE
- C1 0.80 mq.
- SOTTOFONDAZIONE STRADALE
- H1 5.39 mq.
- RILEVATO
- RI1 5.18 mq.
- RIEMPIMENTO
- RP1 66.14 mq.
- VEGETALE AIUOLA
- VA1 9.62 mq.
- TAPPETO DRENANTE
- a1 8.00 ml.
- BINDER
- b1 8.00 ml.
- BONIFICA
- bo1 9.55 ml.
- INERBIMENTO
- i1 32.15 ml.
- SCOTICO
- sc1 9.55 ml.

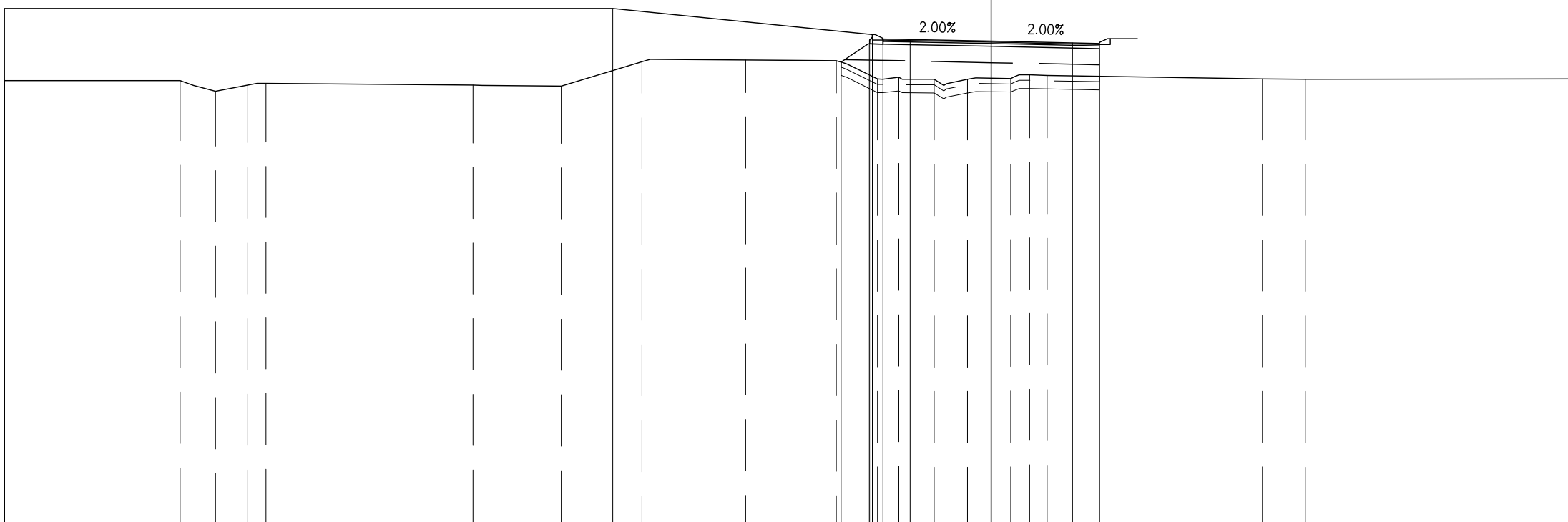

PROGRESSIVE TERRENO	-36.50	-30.00	-28.70	-27.51	-26.82	-19.17	-15.90	-12.92	-9.09	-5.73	-4.21	-3.42	-2.12	-0.88	0.72	1.42	2.06	10.03	11.61	21.55
PARZIALI TERRENO	6.50	1.30	1.19	0.69	7.65	3.27	2.98	3.83	3.36	1.52	0.79	1.30	1.24	1.60	0.70	0.64	7.97	1.58	9.94	
QUOTE TERRENO	14.54	14.54	14.14	14.38	14.44	14.38	14.34	15.24	15.31	15.28	14.60	14.67	14.59	14.59	14.62	14.76	14.74	14.60	14.59	14.61
PROGRESSIVE PROGETTO	-36.50	-36.50	-14.00	-14.00	-14.00	-14.00	-14.00	-14.00	-14.00	-4.40	-4.00	-3.00	0.00	0.00	3.00	4.00	3.00	4.00	4.00	
PARZIALI PROGETTO	22.50	9.60	0.40	1.00	3.00	3.00	1.00	3.00	3.00	0.40	0.40	1.00	1.00	1.00	1.00	1.00	1.00	1.00	1.00	
QUOTE PROGETTO	17.21	14.54	17.21	17.21	16.06	16.06	16.06	16.00	16.00	16.25	16.08	16.06	16.00	16.00	15.94	15.92	15.92	15.92	15.92	
PROGRESSIVE RILEVATO										-5.55	-4.55	-4.50	-4.00	0.00	4.00	4.00	4.00	4.00	4.00	
PARZIALI RILEVATO										1.00	0.05	0.50	4.00	4.00	4.00	4.00	4.00	4.00	4.00	
QUOTE RILEVATO										15.23	15.90	15.90	15.89	15.81	14.70	15.73	15.73	15.73	15.73	

PROFILO SV-FINALE-RO

SEZIONE RO-11

PROGRESSIVA 200.00

BASE	
C1	0.83 mq.
VEGETALE	
D1	1.07 mq.
SOTTOFONDAZIONE STRADALE	
H1	6.37 mq.
RILEVATO ARGINELLO	
RA1	0.07 mq.
RILEVATO	
R11	12.53 mq.
RIEMPIMENTO	
RP1	76.36 mq.
SCAVO FOSSI	
SF1	0.49 mq.
VEGETALE AIUOLA	
VA1	9.62 mq.
RILEVATO FOSSI	
VF1	0.59 mq.
TAPPETO DRENANTE	
a1	8.09 ml.
BINDER	
b1	8.19 ml.
BONIFICA	
bo1	14.41 ml.
INERBIMENTO	
i1	32.15 ml.
i2	3.89 ml.
Totale:	36.04 ml.
SCOTICO	
sc1	14.41 ml.
SCOTICO FOSSI	
sf1	2.49 ml.

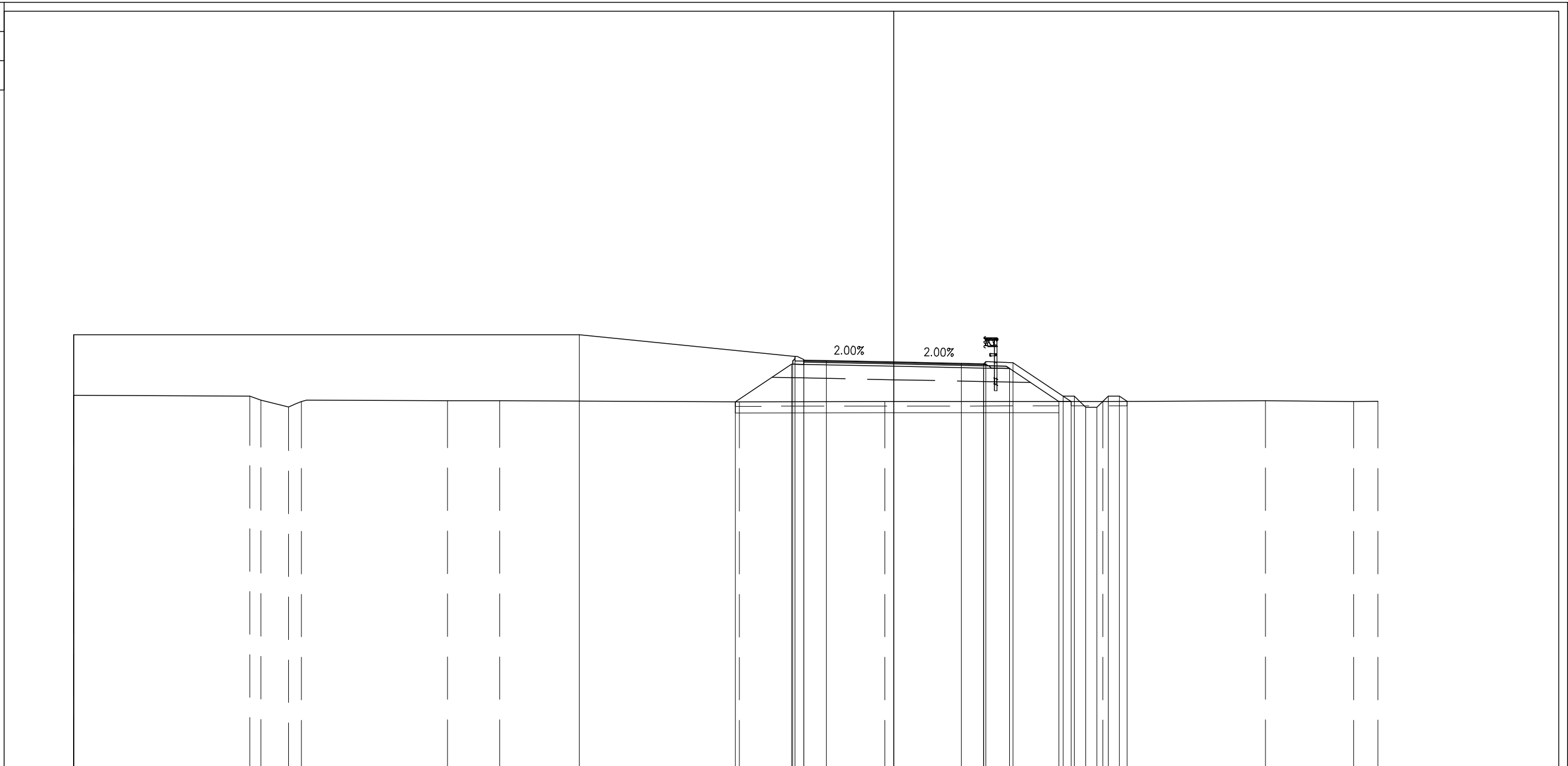

PROGRESSIVE TERRENO	-36.50	-28.67	-28.17	-26.94	-26.37	-19.87	-17.54	-6.87	-0.40	9.31	16.54	20.46	21.55
PARZIALI TERRENO	7.83	0.50	1.23	0.57	6.50	2.33	10.67	6.47	9.71	7.23	3.92	1.09	
QUOTE TERRENO	14.51	14.47	14.31	14.00	14.24	14.27	14.28	14.23	14.24	14.24	14.27	14.24	14.25
PROGRESSIVE PROGETTO	-36.50	-36.50				-14.00		-4.40	-4.00	-3.00	0.00	3.00	3.00
PARZIALI PROGETTO	22.50				9.60		0.40	1.00	3.00	3.00	1.00	0.10	1.20
QUOTE PROGETTO	14.51	17.21	16.25	16.08	16.06	16.00	15.94	15.92	16.02	15.97	14.48	14.48	13.98
PROGRESSIVE RILEVATO						-7.06	-4.55	-4.50	-4.00	0.00	4.00	5.16	7.35
PARZIALI RILEVATO						2.51	0.06	0.50	4.00	4.00	1.16	2.19	0.54
QUOTE RILEVATO						14.23	15.90	15.90	15.89	15.81	15.73	15.71	14.24

PROFILO SV-FINALE-RO

SEZIONE RO-12

PROGRESSIVA 224.99

- BASE
- C1 0.80 mq.
- SOTTOFONDAZIONE STRADALE
- H1 5.39 mq.
- RILEVATO
- RI1 9.88 mq.
- RIEMPIMENTO
- RP1 72.53 mq.
- VEGETALE AIUOLA
- VA1 9.63 mq.
- TAPPETO DRENANTE
- a1 8.00 ml.
- BINDER
- b1 8.00 ml.
- BONIFICA
- bo1 10.91 ml.
- INERBIMENTO
- i1 32.15 ml.
- SCOTICO
- sc1 10.91 ml.

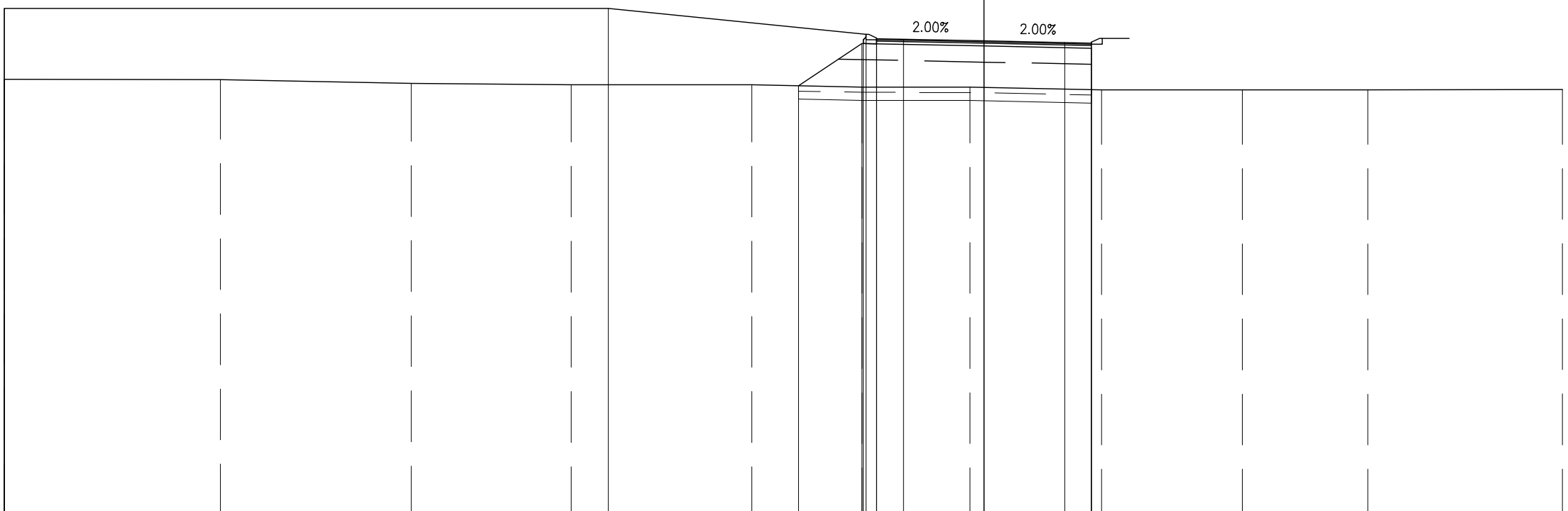

PROGRESSIVE TERRENO	-36.50	-28.46	-21.35	-15.39	-8.65	-4.55	-0.53	4.38	9.62	14.30	21.55
PARZIALI TERRENO	8.04	7.11	5.96	6.74	4.10	4.02	4.91	5.24	4.68	7.25	
QUOTE TERRENO	14.57	14.56	14.41	14.36	14.37	14.28	14.28	14.18	14.18	14.17	14.19
PROGRESSIVE PROGETTO	-36.50	-36.50	-14.00	-4.40	-4.00	-3.00	0.00	3.00	4.00		
PARZIALI PROGETTO	22.50	9.60	0.40	1.00	3.00	3.00	1.00	4.00			
QUOTE PROGETTO	17.21	14.57	17.21	16.25	16.08	16.06	16.00	15.94	15.92		
PROGRESSIVE RILEVATO					-6.91	-4.55	-4.50	-4.00	0.00	4.00	4.00
PARZIALI RILEVATO					2.36	0.06	0.50	4.00	4.00		
QUOTE RILEVATO					14.33	15.90	15.90	15.89	15.81	14.18	15.73

PROFILO SV-FINALE-RO

SEZIONE RO-13

PROGRESSIVA 229.32

- BASE
- C1 0.80 mq.
- SOTTOFONDAZIONE STRADALE
- H1 5.39 mq.
- RILEVATO
- RI1 9.73 mq.
- RIEMPIMENTO
- RP1 72.04 mq.
- VEGETALE AIUOLA
- VA1 9.62 mq.
- TAPPETO DRENANTE
- a1 8.00 ml.
- BINDER
- b1 8.00 ml.
- BONIFICA
- bo1 10.84 ml.
- INERBIMENTO
- i1 32.15 ml.
- SCOTICO
- sc1 10.84 ml.

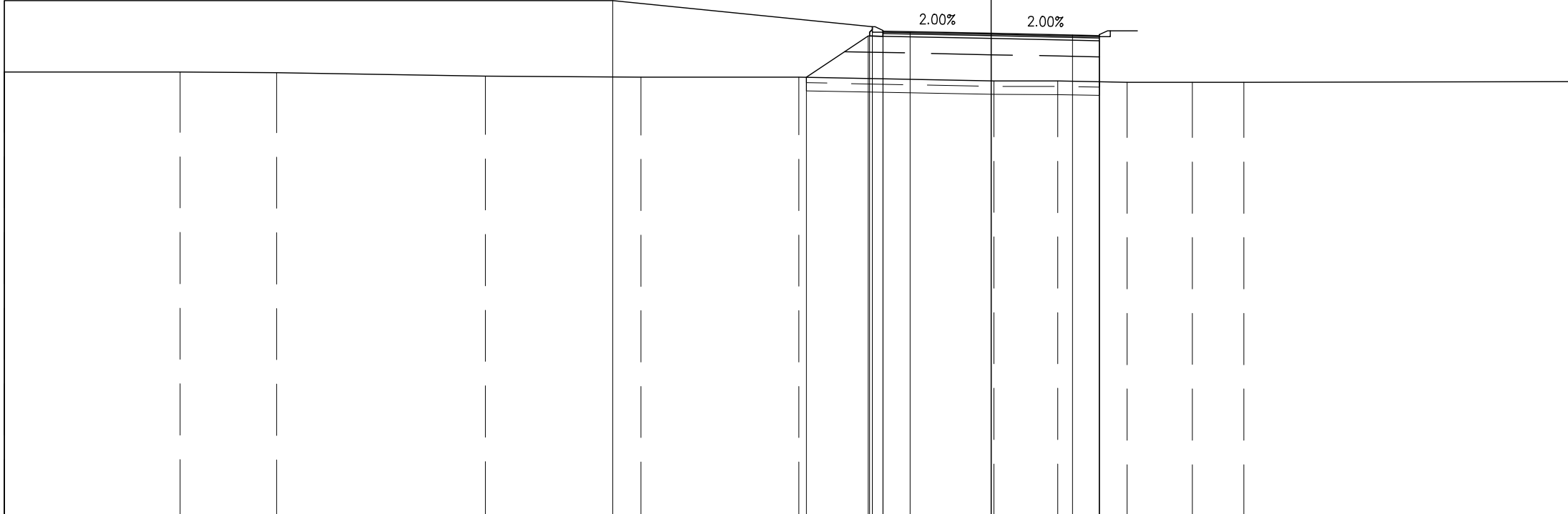

PROGRESSIVE TERRENO	-36.50	-30.00	-26.43	-18.72	-12.96	-7.11	0.10	2.46	5.03	7.43	9.34	21.55
PARZIALI TERRENO	6.50	3.57	7.71	5.76	5.85	7.21	2.36	2.57	2.40	1.91	12.21	
QUOTE TERRENO	14.57	14.57	14.55	14.41	14.37	14.38	14.24	14.23	14.18	14.18	14.18	14.21
PROGRESSIVE PROGETTO	-36.50	-36.50			-14.00		-4.40	-4.00	-3.00	0.00	3.00	4.00
PARZIALI PROGETTO	22.50				9.60		3.00	3.00	1.00	4.00		
QUOTE PROGETTO	17.21	14.57			17.21		16.25	16.08	16.06	16.00	15.94	15.92
PROGRESSIVE RILEVATO						-6.84	-4.55	-4.50	-4.00	0.00	4.00	4.00
PARZIALI RILEVATO						2.29	0.06	0.50	4.00		4.00	
QUOTE RILEVATO						14.37	15.90	15.90	15.89	15.81	14.20	15.73

SVINCOLO DI SAN FELICE SUL PANARO - FINALE EMILIA
RAMO 1
SAT03

PROFILO ASSE1	
SEZIONE ASSE 1-1	
PROGRESSIVA 0.00	
BASE	
C1	2.76 mq.
VEGETALE	
D1	0.86 mq.
D2	1.08 mq.
Totale:	1.94 mq.
SOTTOFONDAZIONE STRADALE	
H1	15.45 mq.
RILEVATO	
R11	6.71 mq.
R12	0.85 mq.
Totale:	7.56 mq.
SCAVO FOSSI	
SF1	0.51 mq.
RILEVATO FOSSI	
VF1	0.90 mq.
TAPPETO DRENANTE	
a1	22.68 ml.
BINDER	
b1	22.88 ml.
BONIFICA	
bo1	21.83 ml.
DEMOLIZIONE SOVRASTRUTTURA	
de1	6.33 ml.
INERBIMENTO	
i2	2.61 ml.
i3	3.29 ml.
Totale:	5.90 ml.
SCOTICO	
sc3	21.83 ml.
SCOTICO FOSSI	
sf1	2.51 ml.

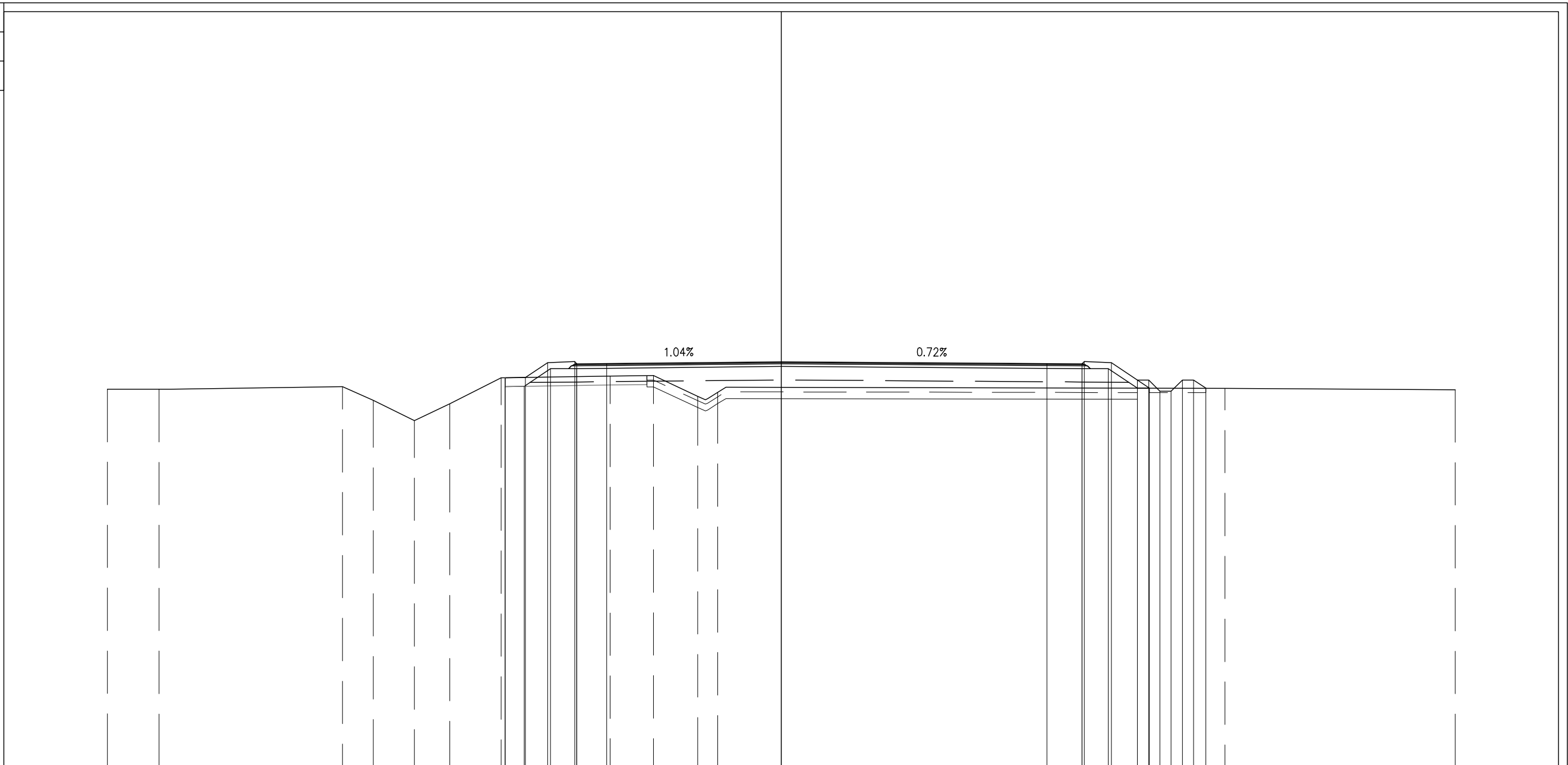

PROGRESSIVE TERRENO	-30.00	-27.69	-19.53	-18.16	-16.33	-14.76	-12.47	-7.61	-5.68	-3.72	-2.83	19.76	30.00											
PARZIALI TERRENO	2.31	8.16	1.37	1.83	1.57	2.29	4.86	1.93	1.96	0.89	22.59	10.24												
QUOTE TERRENO	14.80	14.79	14.91	14.30	13.40	14.14	15.30	15.38	15.40	14.48	14.65	14.84	14.77											
PROGRESSIVE PROGETTO							-12.29	-11.38	-10.40	-9.20	-9.10	-7.77	0.00	11.83	13.39	13.49	14.69	15.86	16.36	16.86	17.36	17.86	18.36	18.90
PARZIALI PROGETTO							0.91	0.98	1.20	0.10	1.33	7.77	11.83	1.56	0.10	1.20	0.50	0.50	0.50	0.50	0.50	0.50	0.50	0.54
QUOTE PROGETTO							15.31	15.32	15.98	16.03	15.93	15.94	16.02	15.93	15.92	16.02	15.98	15.20	15.20	14.70	14.70	15.20	15.20	14.84
PROGRESSIVE RILEVATO							-12.29	-11.44	-10.27	-9.10	0.00	0.00	11.83	13.39	13.39	14.56	15.85	16.39	16.39	16.86	17.36	17.86	18.36	18.90
PARZIALI RILEVATO							0.85	1.17	1.17	9.10	13.39	13.39	1.17	1.29	0.54	1.17	1.29	0.54	0.54	0.54	0.54	0.54	0.54	0.54
QUOTE RILEVATO							14.91	14.92	15.70	15.72	15.81	15.81	15.71	15.71	14.84	14.84	15.71	15.71	14.84	14.84	15.71	15.71	14.84	14.84

PROFILO ASSE1

SEZIONE ASSE 1-2

PROGRESSIVA 25.00

- BASE
- C1 1.15 mq.
- VEGETALE
- D1 0.62 mq.
- D2 0.67 mq.
- Totale: 1.29 mq.
- SOTTOFONDAZIONE STRADALE
- H1 7.23 mq.
- RILEVATO
- R11 0.62 mq.
- R12 0.21 mq.
- Totale: 0.83 mq.
- STERRO
- SC1 0.05 mq.
- SC2 0.73 mq.
- Totale: 0.78 mq.
- SCAVO FOSSI
- SF1 0.51 mq.
- RILEVATO FOSSI
- VF1 0.67 mq.
- TAPPETO DRENANTE
- a1 9.14 ml.
- BINDER
- b1 9.34 ml.
- BONIFICA
- bo1 4.40 ml.
- DEMOLIZIONE SOVRASTRUTTURA
- de1 5.67 ml.
- INERBIMENTO
- i2 1.97 ml.
- i3 2.61 ml.
- Totale: 4.58 ml.
- SCOTICO
- sc3 4.40 ml.
- SCOTICO FOSSI
- sf2 2.52 ml.

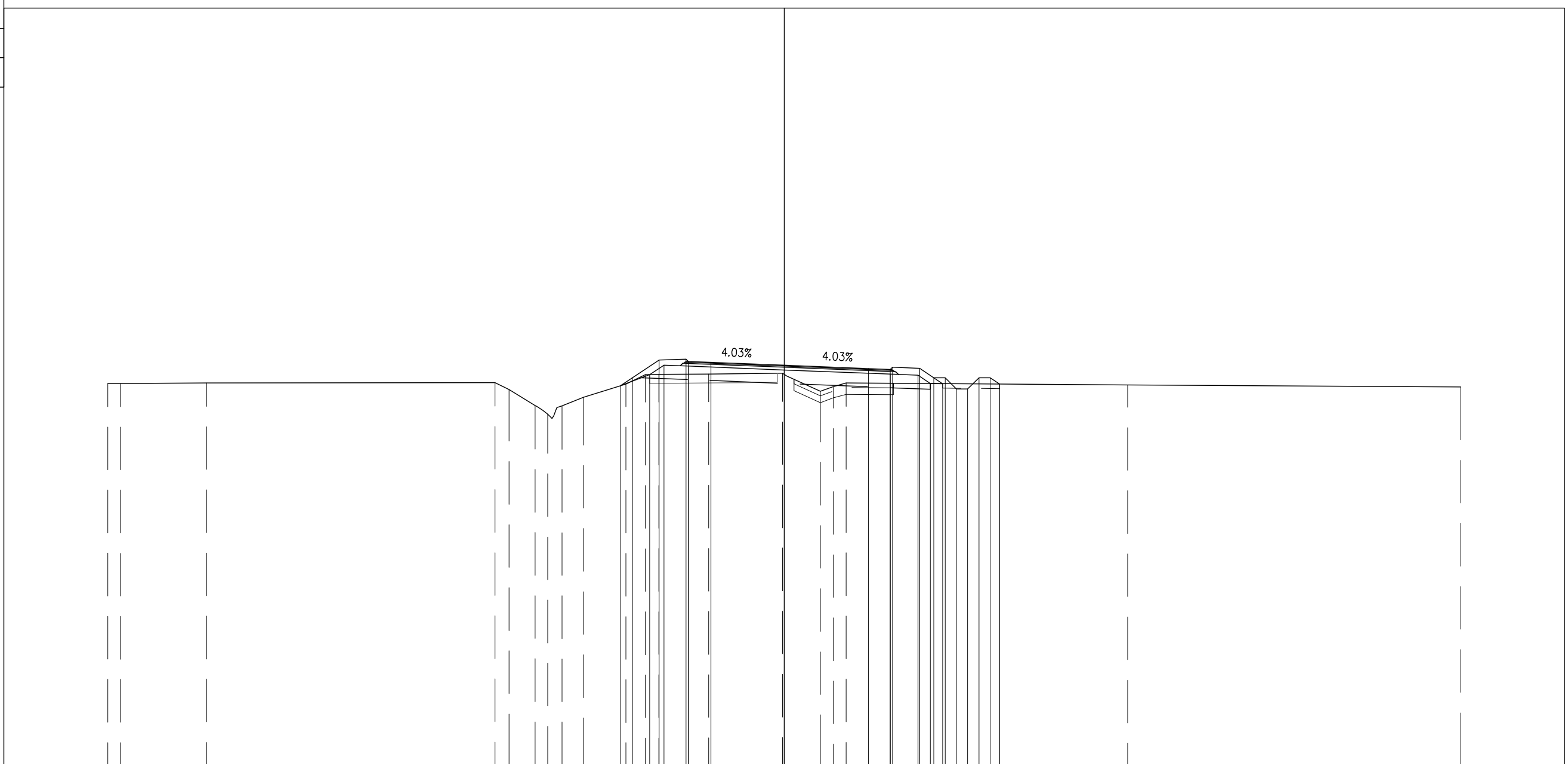

PROGRESSIVE TERRENO	-30.00	-29.44	-25.62	-12.83	-12.20	-11.04	-10.48	-9.86	-8.89	-7.02	-6.15	-5.56	-3.35	-0.07	1.60	2.18	2.74	15.23	30.00
PARZIALI TERRENO	0.56	3.82	12.79	0.63	1.16	0.56	0.62	0.97	1.87	0.87	0.59	2.21	3.28	1.67	0.58	0.56	12.49	14.77	
QUOTE TERRENO	14.94	14.94	14.97	14.99	14.68	13.97	13.58	13.96	14.33	14.93	15.34	15.35	15.37	15.40	14.60	14.81	14.97	14.89	14.79
PROGRESSIVE PROGETTO										-6.72	-5.55	-4.25	-3.25	0.00	3.74	4.70	4.80	6.00	6.64
PARZIALI PROGETTO										1.17	1.20	0.70	1.00	3.25	3.74	0.96	0.10	1.23	0.50
QUOTE PROGETTO										15.20	15.98	16.03	15.93	15.89	15.76	15.67	15.67	15.62	15.20
PROGRESSIVE RILEVATO										-7.24	-5.97	-5.34	-4.25	0.00	4.70	5.93	6.48	7.03	7.64
PARZIALI RILEVATO										1.27	0.63	1.09	4.25	4.70	1.23	0.55	0.56	0.50	0.50
QUOTE RILEVATO										14.85	15.35	15.77	15.72	15.55	15.36	15.31	14.94	14.94	14.94

