



"SERRA CARUSO MOR"

| | | | | |
|--------|-------------------------|-------|-------|-------|
| 1 | PROGETTO REV 00 | MR | 11/21 | |
| REV. | DESCRIZIONE E REVISIONE | Sigla | Data | Firma |
| EMESSO | | | | |

| | | | | | | | |
|---------------|---|----------|---|-------------|---|-----------|---|
| PROGETTAZIONE |  <p>SERVIZI DI INGEGNERIA Via della Pineta 1 - 85100 - Potenza email: info@gvcingegneria.it - website: www.gvcingegneria.it C.F. e P.IVA 01737760767 P.E.C.: gvcstf@gigapec.it</p> <p>Direttore Tecnico: dott. ing. MICHELE RESTAINO</p> <p>Collaboratori GVC s.r.l. per il progetto: dott. ing. GIORGIO MARIA RESTAINO dott. ing. CARLO RESTAINO dott. ing. ATTILIO ZOLFANELLI</p>  <p>GVC s.r.l. Direttore Tecnico Ing. Michele Restaino</p> | GEOLOGIA | <p>Nuova Atlantide soc. coop. a r.l.</p> <p>Località Palazzo snc - 75011 Accettura - Matera email: progettazione@nuovaatlantide.com</p> <p>Direttore Tecnico: geol. ANTONIO DI BIASE</p> <p>Collaboratore per il progetto: geol. TOMMASO SANTOCHIRICO</p> <p>"Nuova Atlantide" Società Cooperativa Località Palazzo, s.n.c. - 75011 Accettura (MT)</p>   | ARCHEOLOGIA | <p>Dott. Antonio Bruscella</p> <p>Piazza Alcide De Gasperi 27 - 85100 - Potenza email: antonio Bruscella@hotmail.it</p>  <p>Dott. Antonio Bruscella ANTONIO BRUSCELLA Architetto, Urbanista Piazza Aldo Moro, 27 - 85100 Potenza tel. +39 0971 260000 email: antonio Bruscella@bruscella.it P.I. 01707990767 - C.F. 01707990767</p> | AGRONOMIA | <p>Dott. agr. Paolo Castelli</p> <p>Viale Croce Rossa 25 - 90144 - Palermo email: paolo.castelli@hotmail.it P.IVA 0546509826</p>   |
|---------------|---|----------|---|-------------|---|-----------|---|

| | | | |
|-------------|--|---|--|
| Committente | <p>AMBRA SOLARE 17 s.r.l. Via XX Settembre n.1 - 00187 ROMA, Italia ambrasolare17sr@legalmail.it C.F. e P.IVA 15946181003 SOCIETA' DEL GRUPPO POWERTIS s.r.l.</p> | <p>POWER TIS s.r.l. Via Tevere, 41 - 00198 ROMA, Italia www.powertis.com</p> |  <p>Powertis</p> |
|-------------|--|---|--|

| | | | | | |
|---|--|-----------------|------------------|-------|--|
| Comune | COMUNE DI CRACO (MT) | COD. RIF | G/139/02/A/01/PD | | |
| Opera | PROGETTO PER LA REALIZZAZIONE DI UN IMPIANTO AGRIVOLTAICO DI POTENZA NOMINALE PARI A 19.994,88 kWp DENOMINATO "SERRA CARUSO MOR" - UBICATO NEL COMUNE DI CRACO (MT) - REGIONE BASILICATA | ELABORATO | FILE | | |
| Oggetto | PROGETTO DEFINITIVO | Categoria | N.° | | |
| | SCEMI FUNZIONALI DEI SINGOLI PANNELLI | PD | Scala | ----- | |
| | | A.12.b.3 | | | |
| Questo disegno è di nostra proprietà riservata a termine di legge e ne è vietata la riproduzione anche parziale senza nostra autorizzazione scritta | | | | | |



Preliminary Technical Information Sheet

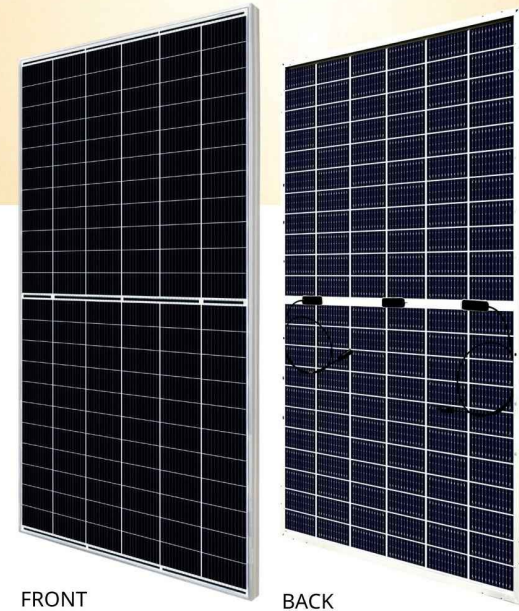

BiHiKu7

BIFACIAL MONO PERC

635 W ~ 655 W

CS7N-635 | 640 | 645 | 650 | 655MB-AG

MORE POWER

- 655 W Module power up to 655 W
Module efficiency up to 21.1 %
- Up to 8.9 % lower LCOE
Up to 4.6 % lower system cost
- Comprehensive LID / LeTID mitigation technology, up to 50% lower degradation
- Compatible with mainstream trackers, cost effective product for utility power plant
- Better shading tolerance

MORE RELIABLE

- 40 °C lower hot spot temperature, greatly reduce module failure rate
- Minimizes micro-crack impacts
- Heavy snow load up to 5400 Pa, wind load up to 2400 Pa*

12 Years Enhanced Product Warranty on Materials and Workmanship*

30 Years Linear Power Performance Warranty*

1st year power degradation no more than 2%
Subsequent annual power degradation no more than 0.45%

*According to the applicable Canadian Solar Limited Warranty Statement.

MANAGEMENT SYSTEM CERTIFICATES*

ISO 9001:2015 / Quality management system
ISO 14001:2015 / Standards for environmental management system
OHSAS 18001:2007 / International standards for occupational health & safety

PRODUCT CERTIFICATES*

* As there are different certification requirements in different markets, please contact your local Canadian Solar sales representative for the specific certificates applicable to the products in the region in which the products are to be used.

CANADIAN SOLAR INC. is committed to providing high quality solar products, solar system solutions and services to customers around the world. Canadian Solar was recognized as the No. 1 module supplier for quality and performance/price ratio in the IHS Module Customer Insight Survey, and is a leading PV project developer and manufacturer of solar modules, with over 46 GW deployed around the world since 2001.

* For detailed information, please refer to the Installation Manual.

CANADIAN SOLAR INC.
545 Speedvale Avenue West, Guelph, Ontario N1K 1E6, Canada, www.csisolar.com, support@csisolar.com

ENGINEERING DRAWING (mm)

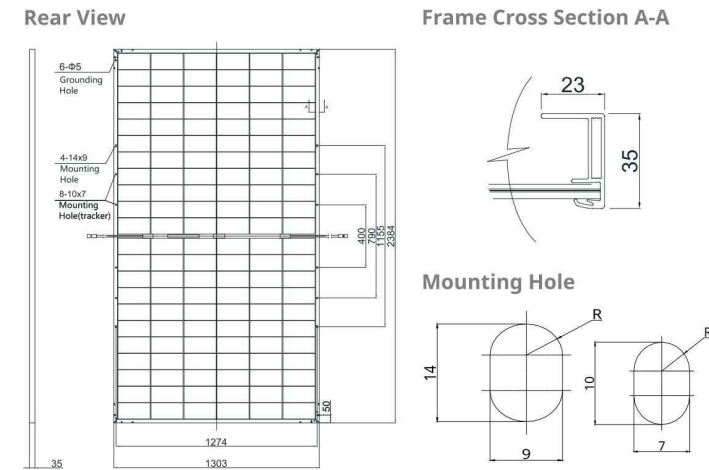

ELECTRICAL DATA | STC*

| | Nominal Max. Power (Pmax) | Opt. Operating Voltage (Vmp) | Opt. Operating Current (Imp) | Open Circuit Voltage (Voc) | Short Circuit Current (Isc) | Module Efficiency |
|------------------------|---------------------------|------------------------------|------------------------------|----------------------------|-----------------------------|-------------------|
| CS7N-635MB-AG | 635 W | 36.7 V | 17.31 A | 44.4 V | 18.27 A | 20.4% |
| Bifacial Gain** | 5% | 667 W | 36.7 V | 18.18 A | 19.18 A | 21.5% |
| | 10% | 699 W | 36.7 V | 19.05 A | 20.10 A | 22.5% |
| | 20% | 762 W | 36.7 V | 20.77 A | 21.92 A | 24.5% |
| CS7N-640MB-AG | 640 W | 36.9 V | 17.35 A | 44.6 V | 18.31 A | 20.6% |
| Bifacial Gain** | 5% | 672 W | 36.9 V | 18.22 A | 19.23 A | 21.6% |
| | 10% | 704 W | 36.9 V | 19.09 A | 20.14 A | 22.7% |
| | 20% | 768 W | 36.9 V | 20.82 A | 21.97 A | 24.7% |
| CS7N-645MB-AG | 645 W | 37.1 V | 17.39 A | 44.8 V | 18.35 A | 20.8% |
| Bifacial Gain** | 5% | 677 W | 37.1 V | 18.26 A | 19.27 A | 21.8% |
| | 10% | 710 W | 37.1 V | 19.14 A | 20.19 A | 22.9% |
| | 20% | 774 W | 37.1 V | 20.87 A | 22.02 A | 24.9% |
| CS7N-650MB-AG | 650 W | 37.3 V | 17.43 A | 45.0 V | 18.39 A | 20.9% |
| Bifacial Gain** | 5% | 683 W | 37.3 V | 18.32 A | 19.31 A | 22.0% |
| | 10% | 715 W | 37.3 V | 19.17 A | 20.23 A | 23.0% |
| | 20% | 780 W | 37.3 V | 20.92 A | 22.07 A | 25.1% |
| CS7N-655MB-AG | 655 W | 37.5 V | 17.47 A | 45.2 V | 18.43 A | 21.1% |
| Bifacial Gain** | 5% | 688 W | 37.5 V | 18.35 A | 19.35 A | 22.1% |
| | 10% | 721 W | 37.5 V | 19.23 A | 20.27 A | 23.2% |
| | 20% | 786 W | 37.5 V | 20.96 A | 22.12 A | 25.3% |

* Under Standard Test Conditions (STC) of irradiance of 1000 W/m², spectrum AM 1.5 and cell temperature of 25°C.
** Bifacial Gain: The additional gain from the back side compared to the power of the front side at the standard test condition. It depends on mounting (structure, height, tilt angle etc.) and albedo of the ground.

ELECTRICAL DATA

| | |
|----------------------------|------------------------------|
| Operating Temperature | -40°C ~ +85°C |
| Max. System Voltage | 1500 V (IEC) or 1000 V (IEC) |
| Module Fire Performance | CLASS C (IEC61730) |
| Max. Series Fuse Rating | 35 A |
| Application Classification | Class A |
| Power Tolerance | 0 ~ + 10 W |
| Power Bifaciality* | 70 % |

* Power Bifaciality = Pmax_{rear} / Pmax_{front}, both Pmax_{rear} and Pmax_{front} are tested under STC, Bifaciality Tolerance: ± 5 %

* The specifications and key features contained in this datasheet may deviate slightly from our actual products due to the on-going innovation and product enhancement. Canadian Solar Inc. reserves the right to make necessary adjustment to the information described herein at any time without further notice.
Please be kindly advised that PV modules should be handled and installed by qualified people who have professional skills and please carefully read the safety and installation instructions before using our PV modules.

CANADIAN SOLAR INC.
545 Speedvale Avenue West, Guelph, Ontario N1K 1E6, Canada, www.csisolar.com, support@csisolar.com

CS7N-650MB-AG / I-V CURVES

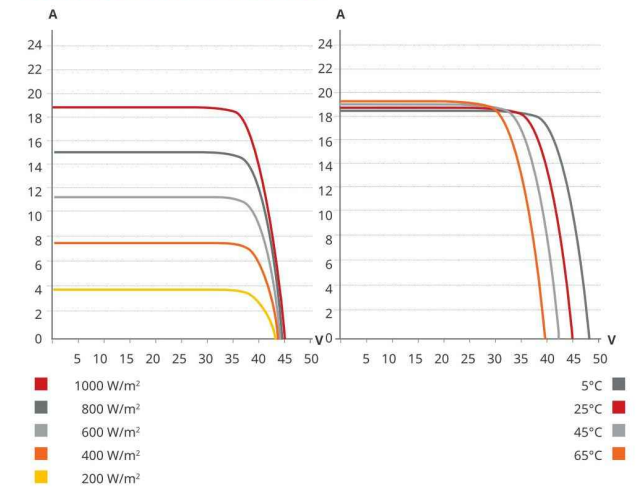

ELECTRICAL DATA | NMOT*

| | Nominal Max. Power (Pmax) | Opt. Operating Voltage (Vmp) | Opt. Operating Current (Imp) | Open Circuit Voltage (Voc) | Short Circuit Current (Isc) |
|----------------------|---------------------------|------------------------------|------------------------------|----------------------------|-----------------------------|
| CS7N-635MB-AG | 475 W | 34.3 V | 13.86 A | 41.9 V | 14.73 A |
| CS7N-640MB-AG | 479 W | 34.5 V | 13.89 A | 42.1 V | 14.77 A |
| CS7N-645MB-AG | 483 W | 34.7 V | 13.92 A | 42.3 V | 14.80 A |
| CS7N-650MB-AG | 487 W | 34.9 V | 13.96 A | 42.5 V | 14.83 A |
| CS7N-655MB-AG | 490 W | 35.1 V | 13.98 A | 42.7 V | 14.86 A |

* Under Nominal Module Operating Temperature (NMOT), irradiance of 800 W/m², spectrum AM 1.5, ambient temperature 20°C, wind speed 1 m/s.

MECHANICAL DATA

| Specification | Data |
|------------------------------------|---|
| Cell Type | Mono-crystalline |
| Cell Arrangement | 132 [2 x (11 x 6)] |
| Dimensions | 2384 x 1303 x 35 mm (93.9 x 51.3 x 1.38 in) |
| Weight | 39.4 kg (86.9 lbs) |
| Front / Back Glass | 2.0 mm heat strengthened glass |
| Frame | Anodized aluminium alloy |
| J-Box | IP68, 3 diodes |
| Cable | 4.0 mm ² (IEC) |
| Cable Length (Including Connector) | 460 mm (18.1 in) (+) / 340 mm (13.4 in) (-) or customized length* |
| Connector | T4 series or H4 UTX or MC4-EVO2 |
| Per Pallet | 30 pieces |
| Per Container (40' HQ) | 480 pieces |

* For detailed information, please contact your local Canadian Solar sales and technical representatives.

TEMPERATURE CHARACTERISTICS

| Specification | Data |
|--------------------------------------|--------------|
| Temperature Coefficient (Pmax) | -0.35 % / °C |
| Temperature Coefficient (Voc) | -0.27 % / °C |
| Temperature Coefficient (Isc) | 0.05 % / °C |
| Nominal Module Operating Temperature | 41 ± 3°C |

PARTNER SECTION

