



REGIONE BASILICATA
 PROVINCIA DI MATERA
 COMUNE DI IRSINA



PROGETTO DEFINITIVO

Autorizzazione Unica ex art. 12 del d.lgs. 387/2003

Impianto fotovoltaico di potenza nominale pari a 19,992 MW e relative opere di connessione proposti dalla ditta Basilicata Solare s.r.l. nel territorio di Irsina

Titolo elaborato

**Piano di Manutenzione e gestione
 dell'impianto:
 B.1.a. Parte generale**

Codice elaborato

COMMESSA	FASE	ELABORATO	REV.
F0315	H	R14	A

Riproduzione o consegna a terzi solo dietro specifica autorizzazione.

Scala

—

DATA	DESCRIZIONE	REDATTO	VERIFICATO	APPROVATO
Maggio 2020	Prima emissione	MRO	GDS	GZU

Proponente

Basilicata Solare s.r.l.

Via della Ferula 46
 70022 Altamura (BA)

BASILICATA SOLARE S.r.l.
 amministratore

Progettazione



F4 Ingegneria srl

Via Di Giura - Centro direzionale, 85100 Potenza
 Tel: +39 0971 1944797 - Fax: +39 0971 55452
 www.f4ingegneria.it - f4ingegneria@pec.it

Il Responsabile del Gruppo di Verifica
 (ing. Giorgio ZUCCARO)



Società certificata secondo la norma UNI-EN ISO 9001:2015 per l'erogazione di servizi di ingegneria nei settori: civile, idraulica, acustica, energia, ambiente (settore IAF: 34).





Sommario

1 Premessa	2
2 Lista anagrafica dei componenti dell'impianto	3
3 Schede tecniche dei componenti dell'impianto	4
ALLEGATO 1: Cabine di campo MY POWER STATION	5
ALLEGATO 2: Inverter solari SUNNY CENTRAL UP	6
ALLEGATO 3: Pannelli fotovoltaici TRINA SOLAR DUOMAX TWIN DEG18MC.20(II)	7



1 Premessa

Il presente progetto si riferisce alla realizzazione dell'impianto fotovoltaico di grande generazione nel territorio comunale di Irsina (MT) e delle opere ad esso connesse nel territorio comunale di Grottole (MT). Nella fattispecie l'impianto, caratterizzato da una potenza di picco di 19.992 MWp, sarà utilizzato per la restituzione dell'energia nella rete Terna mediante la connessione alla cabina RTN condivisa di Grottole caratterizzata da una tensione nominale di 15 kV e al momento non esistente, ma prevista in progetto.





2 Lista anagrafica dei componenti dell'impianto

I principali componenti dell'impianto fotovoltaico di progetto sono:

- I pannelli fotovoltaici (vedi allegato 3);
- Le strutture metalliche di supporto;
- Le fondazioni delle strutture;
- L'inverter delle caratteristiche tecniche riportate nella scheda tecnica di questo componente (vedi allegato 2);
- Le cabine elettriche di campo e di interconnessione (vedi allegato 1);
- I cavidotti ed i conduttori elettrici;
- Il sistema di monitoraggio e controllo SCADA.



3 Schede tecniche dei componenti dell'impianto

In dettaglio, l'impianto fotovoltaico è dotato di:

- numero di cabine di campo: 5;
- numero di inverter: 5;
- potenza di picco: 19 992 000 Wp;
- numero di pannelli fotovoltaici: 40 791;
- potenza nominale in corrente alternata (a 50°C): 17 000 kVA.

L'impianto, inoltre, è suddiviso in 5 "sottocampi", ciascuno dei quali è collegato ad una cabina di campo ed è caratterizzato da una potenza di picco pari a circa 4 MWp.

Si allegano, ad integrazione del presente documento, le schede tecniche dei componenti dell'impianto relative a:

- Cabine di campo;
- Inverter solari;
- Pannelli fotovoltaici.





ALLEGATO 1: Cabine di campo MY POWER STATION



MV POWER STATION

4400 / 4950 / 5000 / 5500 / 6000



MVPS 4400-20 / MVPS 4950-20 / MVPS 5000-20 / MVPS 5500-20 / MVPS 6000-20



Robust

- Station and all individual components type-tested
- Optimally suited to extreme ambient conditions

Easy to Use

- Plug and play concept
- Walk-in control rooms
- Completely pre-assembled for easy set-up and commissioning

Cost-Effective

- Easy planning and installation
- Low transport costs due to 40-foot container

Flexible

- Global solution for international markets
- Numerous options
- Compatible with MVPS 2200 – MVPS 3000

MV POWER STATION 4400 / 4950 / 5000 / 5500 / 6000

Turnkey Solution for PV Power Plants

With the double power of the new robust central inverters, the Sunny Central or Sunny Central Storage, and with perfectly adapted medium-voltage components, the new MV Power Station offers even more power density and is a turnkey solution available worldwide. The solution is the ideal choice for new generation PV power plants operating at 1500 V_{DC}. Delivered pre-configured in a 40-foot container, the solution is easy to transport and quick to assemble and commission. The MVPS and all components are type-tested. The MV Power Station combines rigorous plant safety with maximum energy yield and minimized deployment and operating risk.

MV POWER STATION

4400 / 4950 / 5000 / 5500 / 6000

Technical Data	MV Power Station 4400
Input (DC)	
Available inverters	2 x SC 2200 or 2 x SCS 2200
Max. input voltage	1100 V
Max. input current	2 x 3960 A
Number of DC inputs	2 x 24 double pole fused (2 x 32 single pole fused)
Integrated zone monitoring	○
Available DC fuse sizes (per input)	200 A, 250 A, 315 A, 350 A, 400 A, 450 A, 500 A
Output (AC) on the medium-voltage side	
Standard power at 1000 m and $\cos \varphi = 1$ (at -25°C to 35°C / at 40°C / at 45°C) ¹⁾	4400 kVA / 4000 kVA / 0 kVA
Optionale power at 1000 m and $\cos \varphi = 1$ (at -25°C to 35°C / at 50°C / at 55°C) ¹⁾	4400 kVA / 4000 kVA / 0 kVA
Typical nominal AC voltages	11 kV to 35 kV
AC power frequency	50 Hz / 60 Hz
Transformer vector group Dy11y11 / YNd11d11	● / ○
Transformer cooling methods ONAF ²⁾ / KNAF ²⁾	● / ○
Max. output current at 33 kV	78 A
Transformer no-load losses Standard / Ecodesign at 33 kV	2.8 kW / 3.9 kW
Transformer short-circuit losses Standard / Ecodesign at 33 kV	37.5 kW / 37.5 kW
Max. total harmonic distortion	< 3%
Reactive power feed-in	○ up to 60% of AC power
Power factor at rated power / displacement power factor adjustable	1 / 0.8 overexcited to 0.8 underexcited
Inverter efficiency	
Max. efficiency ³⁾	98.6%
European efficiency ³⁾	98.4%
CEC weighted efficiency ⁴⁾	98.0%
Protective devices	
Input-side disconnection point	DC load-break switch
Output-side disconnection point	Medium-voltage vacuum circuit breaker
DC overvoltage protection	Surge arrester type I
Galvanic isolation	●
Internal arc classification medium-voltage control room (according to IEC 62271-202)	IAC A 20 kA 1 s
General Data	
Dimensions of the 40-foot High Cube ISO container (W / H / D) ⁵⁾	12192 mm / 2896 mm / 2438 mm
Weight	< 26 t
Self-consumption (max. / partial load / average) ¹⁾	< 16.2 kW / < 3.6 kW / < 4.0 kW
Self-consumption (stand-by) ¹⁾	< 600 W
Degree of protection according to IEC 60529	Control rooms IP23D, inverter electronics IP65
Environment: standard / chemically active / dusty	● / ○ / ○
Degree of protection according to IEC 60721-3-4 (4C1, 4S2 / 4C2, 4S2 / 4C2, 4S4)	● / ○ / ○
Maximum permissible value for relative humidity	15% to 95%
Max. operating altitude above mean sea level 1000 m / 2000 m / 3000 m / 4000	● / ○ / ○ / ○ (earlier temperature-dependent de-rating)
Fresh air consumption of inverter and transformer	20000 m ³ /h
Features	
DC terminal	Terminal lug
AC connection	Outer-cone angle plug
Tap changer for MV-transformer: without / with	● / ○
Shield winding for MV-Transformer: without / with	● / ○
Communication package	○
Station enclosure color	RAL 7004
Transformer for external loads: without / 30 kVA / 40 kVA / 50 kVA / 60 kVA	● / ○ / ○ / ○ / ○
Medium-voltage switchgear: without / 2 feeders / 3 feeders	● / ○ / ○
1 or 2 cable feeders with load-break switch, 1 transformer feeder with circuit breaker, internal arc classification IAC A FL 20 kA 1 s according to IEC 62271-200	
Accessories for medium-voltage switchgear: without / auxiliary contacts / motor for transformer feeder / cascade control / monitoring	● / ○ / ○ / ○ / ○
Oil containment: without / with (integrated)	● / ○
Industry standards (for other standards see the inverter datasheet)	IEC 62271-202, IEC 62271-200, IEC 60076 , CSC certificate, EN 50588-1
● Standard features ○ Optional features – Not available	
Type designation	MVPS-4400-20

- 1) Data based on inverter
- 2) ONAF = Mineral oil with forced air cooling; KNAF = Organic oil with forced air cooling
- 3) Efficiency measured at inverter without internal power supply
- 4) Efficiency measured at inverter with internal power supply
- 5) Transport dimensions

MV Power Station 4950	MV Power Station 5000	MV Power Station 5500	MV Power Station 6000
2 x SC 2475 or 2 x SCS 2475	2 x SC 2500-EV or 2 x SCS 2500-EV	2 x SC 2750-EV or 2 x SCS 2750-EV	2 x SC 3000-EV or 2 x SCS 3000-EV
1100 V	1500 V	1500 V	1500 V
2 x 3960 A	2 x 3200 A	2 x 3200 A	2 x 3200 A
○	2 x 24 double pole fused (2 x 32 single pole fused) ○	○	○
	200 A, 250 A, 315 A, 350 A, 400 A, 450 A, 500 A		
4950 kVA / 4500 kVA / 0 kVA	5000 kVA / 4500 kVA / 0 kVA	5500 kVA / 5000 kVA / 0 kVA	6000 kVA / 5400 kVA / 0 kVA
4950 kVA / 4500 kVA / 0 kVA	5000 kVA / 4500 kVA / 0 kVA	5500 kVA / 5000 kVA / 0 kVA	6000 kVA / 5400 kVA / 0 kVA
11 kV to 35 kV	11 kV to 35 kV	11 kV to 35 kV	11 kV to 35 kV
50 Hz / 60 Hz	50 Hz / 60 Hz	50 Hz / 60 Hz	50 Hz / 60 Hz
● / ○	● / ○	● / ○	● / ○
● / ○	● / ○	● / ○	● / ○
87 A	88 A	97 A	105 A
3.1 kW / 4.0 kW	3.1 kW / 4.0 kW	3.1 kW / 4.0 kW	3.2 kW / 4.5 kW
37.5 kW / 37.5 kW	37.5 kW / 37.5 kW	40.0 kW / 40.0 kW	45.5 kW / 45.5 kW
< 3%	< 3%	< 3%	< 3%
○ up to 60% of AC power	○ up to 60% of AC power	○ up to 60% of AC power	○ up to 60% of AC power
1 / 0.8 overexcited to 0.8 underexcited	1 / 0.8 overexcited to 0.8 underexcited	1 / 0.8 overexcited to 0.8 underexcited	1 / 0.8 overexcited to 0.8 underexcited
98.6%	98.6%	98.7%	98.8%
98.4%	98.3%	98.6%	98.6%
98.0%	98.0%	98.5%	98.5%
DC load-break switch	DC load-break switch	DC load-break switch	DC load-break switch
Medium-voltage vacuum circuit breaker	Medium-voltage vacuum circuit breaker	Medium-voltage vacuum circuit breaker	Medium-voltage vacuum circuit breaker
Surge arrester type I	Surge arrester type I	Surge arrester type I	Surge arrester type I
●	●	●	●
IAC A 20kA 1s	IAC A 20kA 1s	IAC A 20kA 1s	IAC A 20kA 1s
12192 mm / 2896 mm / 2438 mm	12192 mm / 2896 mm / 2438 mm	12192 mm / 2896 mm / 2438 mm	12192 mm / 2896 mm / 2438 mm
< 26 t	< 26 t	< 26 t	< 26 t
< 16.2 kW / < 3.6 kW / < 4.0 kW	< 16.2 kW / < 3.6 kW / < 4.0 kW	< 16.2 kW / < 3.6 kW / < 4.0 kW	< 16.2 kW / < 3.6 kW / < 4.0 kW
< 600 W	< 740 W	< 740 W	< 740 W
Control rooms IP23D, inverter electronics IP65			
● / ○ / ○	● / ○ / ○	● / ○ / ○	● / ○ / ○
● / ○ / ○	● / ○ / ○	● / ○ / ○	● / ○ / ○
15% to 95%	15% to 95%	15% to 95%	15% to 95%
● / ○ / ○ / ○ (earlier temperature-dependent de-rating)	● / ○ / ○ / ○ (earlier temperature-dependent de-rating)		
20000 m ³ /h	20000 m ³ /h	20000 m ³ /h	20000 m ³ /h
Terminal lug	Terminal lug	Terminal lug	Terminal lug
Outer-cone angle plug	Outer-cone angle plug	Outer-cone angle plug	Outer-cone angle plug
● / ○	● / ○	● / ○	● / ○
● / ○	● / ○	● / ○	● / ○
○	○	○	○
RAL 7004	RAL 7004	RAL 7004	RAL 7004
● / ○ / ○ / ○ / ○	● / ○ / ○ / ○ / ○	● / ○ / ○ / ○ / ○	● / ○ / ○ / ○ / ○
● / ○ / ○	● / ○ / ○	● / ○ / ○	● / ○ / ○
● / ○ / ○ / ○ / ○	● / ○ / ○ / ○ / ○	● / ○ / ○ / ○ / ○	● / ○ / ○ / ○ / ○
● / ○	● / ○	● / ○	● / ○
IEC 62271-202, IEC 62271-200, IEC 60076 , CSC certificate, EN 50588-1			
MVPS-4950-20	MVPS-5000-20	MVPS-5500-20	MVPS-6000-20

System diagram with Sunny Central

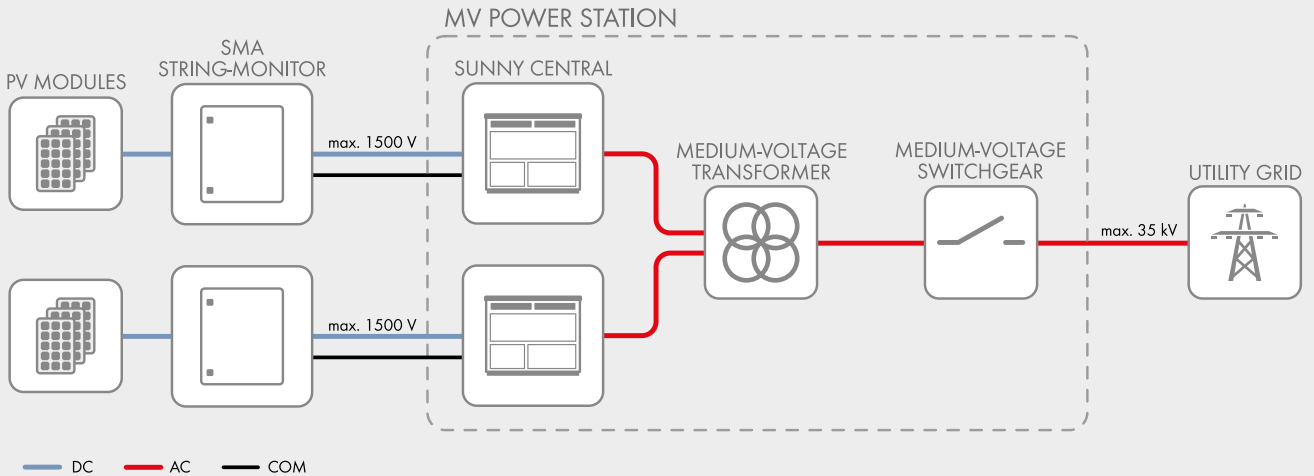

System diagram with Sunny Central Storage

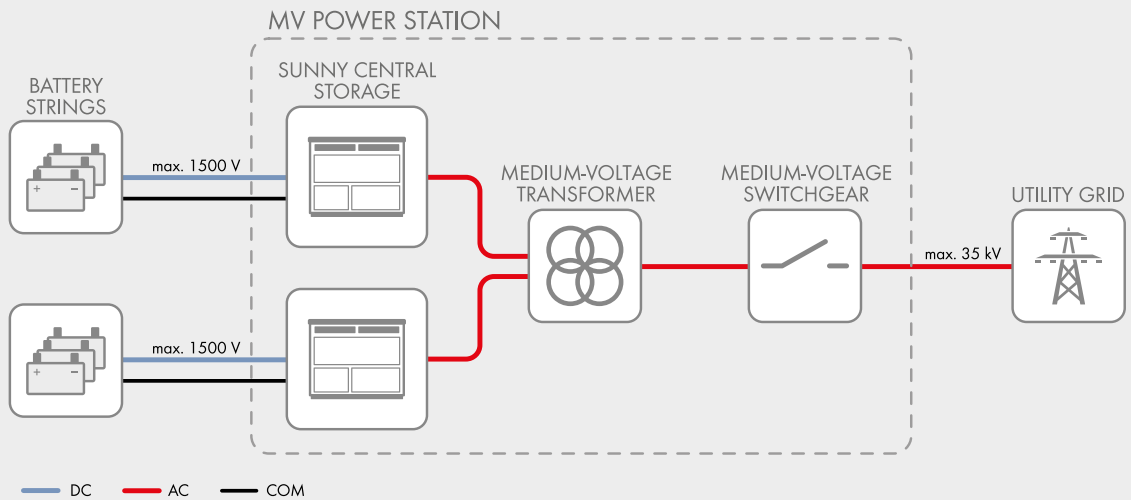



ALLEGATO 2: Inverter solari SUNNY **CENTRAL UP**



SC 4000 UP / SC 4200 UP / SC 4400 UP / SC 4600 UP



preliminary

Efficient

- Up to 4 inverters can be transported in one standard shipping container
- Overdimensioning up to 150% is possible
- Full power at ambient temperatures of up to 25 °C

Robust

- Intelligent air cooling system OptiCool for efficient cooling
- Suitable for outdoor use in all climatic ambient conditions worldwide

Flexible

- Conforms to all known grid requirements worldwide
- Q on demand
- Available as a single device or turnkey solution, including medium-voltage block

Easy to Use

- Improved DC connection area
- Connection area for customer equipment
- Integrated voltage support for internal and external loads

SUNNY CENTRAL UP

The new Sunny Central: more power per cubic meter

With an output of up to 4600 kVA and system voltages of 1500 V DC, the SMA central inverter allows for more efficient system design and a reduction in specific costs for PV power plants. A separate voltage supply and additional space are available for the installation of customer equipment. True 1500 V technology and the intelligent cooling system OptiCool ensure smooth operation even in extreme ambient temperature as well as a long service life of 25 years.

Technical Data	SC 4000 UP	SC 4200 UP
Input (DC)		
MPP voltage range V_{DC} (at 25 °C / at 50 °C)	880 to 1325 V / 1100 V	921 to 1325 V / 1100 V
Min. input voltage $V_{DC, min}$ / Start voltage $V_{DC, Start}$	849 V / 1030 V	891 V / 1071 V
Max. input voltage $V_{DC, max}$	1500 V	1500 V
Max. input current $I_{DC, max}$	4750 A	4750 A
Max. short-circuit current $I_{DC, SC}$	6400 A	6400 A
Number of DC inputs	24 double pole fused (32 single pole fused)	
Max. number of DC cables per DC input (for each polarity)	2 x 800 kcmil, 2 x 400 mm ²	
Integrated zone monitoring	○	
Available DC fuse sizes (per input)	200 A, 250 A, 315 A, 350 A, 400 A, 450 A, 500 A	
Output (AC)		
Nominal AC power at $\cos \varphi = 1$ (at 25 °C / at 50 °C)	4000 kVA / 3400 kVA	4200 kVA / 3570 kVA
Nominal AC power at $\cos \varphi = 0.8$ (at 25 °C / at 50 °C)	3200 kW / 2720 kW	3360 kW / 2856 kW
Nominal AC current $I_{AC, nom}$ (at 25 °C / at 50 °C)	3850 A / 3273 A	3850 A / 3273 A
Max. total harmonic distortion	< 3% at nominal power	
Nominal AC voltage / nominal AC voltage range ^{1) 8)}	600 V / 480 V to 720 V	630 V / 504 V to 756 V
AC power frequency / range	50 Hz / 47 Hz to 53 Hz 60 Hz / 57 Hz to 63 Hz	
Min. short-circuit ratio at the AC terminals ⁹⁾	> 2	
Power factor at rated power / displacement power factor adjustable ^{8) 10)}	1 / 0.8 overexcited to 0.8 underexcited	
Efficiency		
Max. efficiency ²⁾ / European efficiency ²⁾ / CEC efficiency ³⁾	98.7%* / 98.6%* / 98.5%*	98.7%* / 98.6%* / 98.5%*
Protective Devices		
Input-side disconnection point	DC load break switch	
Output-side disconnection point	AC circuit breaker	
DC overvoltage protection	Surge arrester, type I	
AC overvoltage protection (optional)	Surge arrester, class I	
Lightning protection (according to IEC 62305-1)	Lightning Protection Level III	
Ground-fault monitoring / remote ground-fault monitoring	○ / ○	
Insulation monitoring	○	
Degree of protection: electronics / air duct / connection area (as per IEC 60529)	IP54 / IP34 / IP34	
General Data		
Dimensions (W / H / D)	2780 / 2318 / 1588 mm (109.4 / 91.3 / 62.5 inch)	
Weight	< 4000 kg / < 8818.5 lb	
Self-consumption (max. ⁴⁾ / partial load ⁵⁾ / average ⁶⁾	< 8100 W / < 1800 W / < 2000 W	
Self-consumption (standby)	< 370 W	
Internal auxiliary power supply	○ Integrated 8.4 kVA transformer	
Operating temperature range ⁸⁾	-25 °C to 60 °C / -13 °F to 140 °F	
Noise emission ⁷⁾	67.0 dB(A)*	
Temperature range (standby)	-40 °C to 60 °C / -40 °F to 140 °F	
Temperature range (storage)	-40 °C to 70 °C / -40 °F to 158 °F	
Max. permissible value for relative humidity (condensing / non-condensing)	95% to 100% (2 month/year) / 0% to 95%	
Maximum operating altitude above MSL ⁸⁾ 1000 m / 2000 m / 3000 m	● / ○ / ○ (earlier temperature-dependent derating)	
Fresh air consumption	6500 m ³ /h	
Features		
DC connection	Terminal lug on each input (without fuse)	
AC connection	With busbar system (three busbars, one per line conductor)	
Communication	Ethernet, Modbus Master, Modbus Slave	
Communication with SMA string monitor (transmission medium)	Modbus TCP / Ethernet (FO MM, Cat-5)	
Enclosure / roof color	RAL 9016 / RAL 7004	
Supply transformer for external loads	○ (2.5 kVA)	
Standards and directives complied with	CE, IEC / EN 62109-1, IEC / EN 62109-2, AR-N 4110, IEEE1547, UL 840 Cat. IV, Arrêté du 23/04/08	
EMC standards	IEC 55011, FCC Part 15 Class A	
Quality standards and directives complied with	VDI/VDE 2862 page 2, DIN EN ISO 9001	
● Standard features ○ Optional * preliminary		
Type designation	SC 4000 UP	SC 4200 UP

1) At nominal AC voltage, nominal AC power decreases in the same proportion
 2) Efficiency measured without internal power supply
 3) Efficiency measured with internal power supply
 4) Self-consumption at rated operation
 5) Self-consumption at < 75% Pn at 25 °C
 6) Self-consumption averaged out from 5% to 100% Pn at 25 °C

7) Sound pressure level at a distance of 10 m
 8) Values apply only to inverters. Permissible values for SMA MV solutions from SMA can be found in the corresponding data sheets.
 9) A short-circuit ratio of < 2 requires a special approval from SMA
 10) Depending on the DC voltage

Technical Data	SC 4400 UP	SC 4600 UP
Input (DC)		
MPP voltage range V_{DC} (at 25 °C / at 50 °C)	962 to 1325 V / 1100 V	1003 to 1325 V / 1100 V
Min. input voltage $V_{DC, min}$ / Start voltage $V_{DC, Start}$	934 V / 1112 V	976 V / 1153 V
Max. input voltage $V_{DC, max}$	1500 V	1500 V
Max. input current $I_{DC, max}$	4750 A	4750 A
Max. short-circuit current $I_{DC, SC}$	6400 A	6400 A
Number of DC inputs	24 double pole fused (32 single pole fused)	
Max. number of DC cables per DC input (for each polarity)	2 x 800 kcmil, 2 x 400 mm ²	
Integrated zone monitoring	○	
Available DC fuse sizes (per input)	200 A, 250 A, 315 A, 350 A, 400 A, 450 A, 500 A	
Output (AC)		
Nominal AC power at $\cos \varphi = 1$ (at 25 °C / at 50 °C)	4400 kVA / 3740 kVA	4600 kVA / 3910 kVA
Nominal AC power at $\cos \varphi = 0.8$ (at 25 °C / at 50 °C)	3520 kW / 2992 kW	3680 kW / 3128 kW
Nominal AC current $I_{AC, nom}$ (at 25 °C / at 50 °C)	3850 A / 3273 A	3850 A / 3273 A
Max. total harmonic distortion	< 3% at nominal power	
Nominal AC voltage / nominal AC voltage range ^{1) 8)}	660 V / 528 V to 759 V	690 V / 552 V to 759 V
AC power frequency / range	50 Hz / 47 Hz to 53 Hz 60 Hz / 57 Hz to 63 Hz	
Min. short-circuit ratio at the AC terminals ⁹⁾	> 2	
Power factor at rated power / displacement power factor adjustable ^{8) 10)}	● 1 / 0.8 overexcited to 0.8 underexcited	
Efficiency		
Max. efficiency ²⁾ / European efficiency ²⁾ / CEC efficiency ³⁾	98.7%* / 98.6%* / 98.5%*	98.7%* / 98.6%* / 98.5%*
Protective Devices		
Input-side disconnection point	DC load break switch	
Output-side disconnection point	AC circuit breaker	
DC overvoltage protection	Surge arrester, type I	
AC overvoltage protection (optional)	Surge arrester, class I	
Lightning protection (according to IEC 62305-1)	Lightning Protection Level III	
Ground-fault monitoring / remote ground-fault monitoring	○ / ○	
Insulation monitoring	○	
Degree of protection: electronics / air duct / connection area (as per IEC 60529)	IP54 / IP34 / IP34	
General Data		
Dimensions (W / H / D)	2780 / 2318 / 1588 mm (109.4 / 91.3 / 62.5 inch)	
Weight	< 4000 kg / < 8818.5 lb	
Self-consumption (max. ⁴⁾ / partial load ⁵⁾ / average ⁶⁾	< 8100 W / < 1800 W / < 2000 W	
Self-consumption (standby)	< 370 W	
Internal auxiliary power supply	○ Integrated 8.4 kVA transformer	
Operating temperature range ⁸⁾	-25 °C to 60 °C / -13 °F to 140 °F	
Noise emission ⁷⁾	67.0 dB(A)*	
Temperature range (standby)	-40 °C to 60 °C / -40 °F to 140 °F	
Temperature range (storage)	-40 °C to 70 °C / -40 °F to 158 °F	
Max. permissible value for relative humidity (condensing / non-condensing)	95% to 100% (2 month/year) / 0% to 95%	
Maximum operating altitude above MSL ⁸⁾ 1000 m / 2000 m / 3000 m	● / ○ / ○ (earlier temperature-dependent derating)	
Fresh air consumption	6500 m ³ /h	
Features		
DC connection	Terminal lug on each input (without fuse)	
AC connection	With busbar system (three busbars, one per line conductor)	
Communication	Ethernet, Modbus Master, Modbus Slave	
Communication with SMA string monitor (transmission medium)	Modbus TCP / Ethernet (FO MM, Cat-5)	
Enclosure / roof color	RAL 9016 / RAL 7004	
Supply transformer for external loads	○ (2.5 kVA)	
Standards and directives complied with	CE, IEC / EN 62109-1, IEC / EN 62109-2, AR-N 4110, IEEE1547, UL 840 Cat. IV, Arrêté du 23/04/08	
EMC standards	IEC 55011, FCC Part 15 Class A	
Quality standards and directives complied with	VDI/VDE 2862 page 2, DIN EN ISO 9001	
● Standard features ○ Optional * preliminary		
Type designation	SC 4400 UP	SC 4600 UP

1) At nominal AC voltage, nominal AC power decreases in the same proportion

2) Efficiency measured without internal power supply

3) Efficiency measured with internal power supply

4) Self-consumption at rated operation

5) Self-consumption at < 75% Pn at 25 °C

6) Self-consumption averaged out from 5% to 100% Pn at 25 °C

7) Sound pressure level at a distance of 10 m

8) Values apply only to inverters. Permissible values for SMA MV solutions from SMA can be found in the corresponding data sheets.

9) A short-circuit ratio of < 2 requires a special approval from SMA

10) Depending on the DC voltage

SYSTEM DIAGRAM

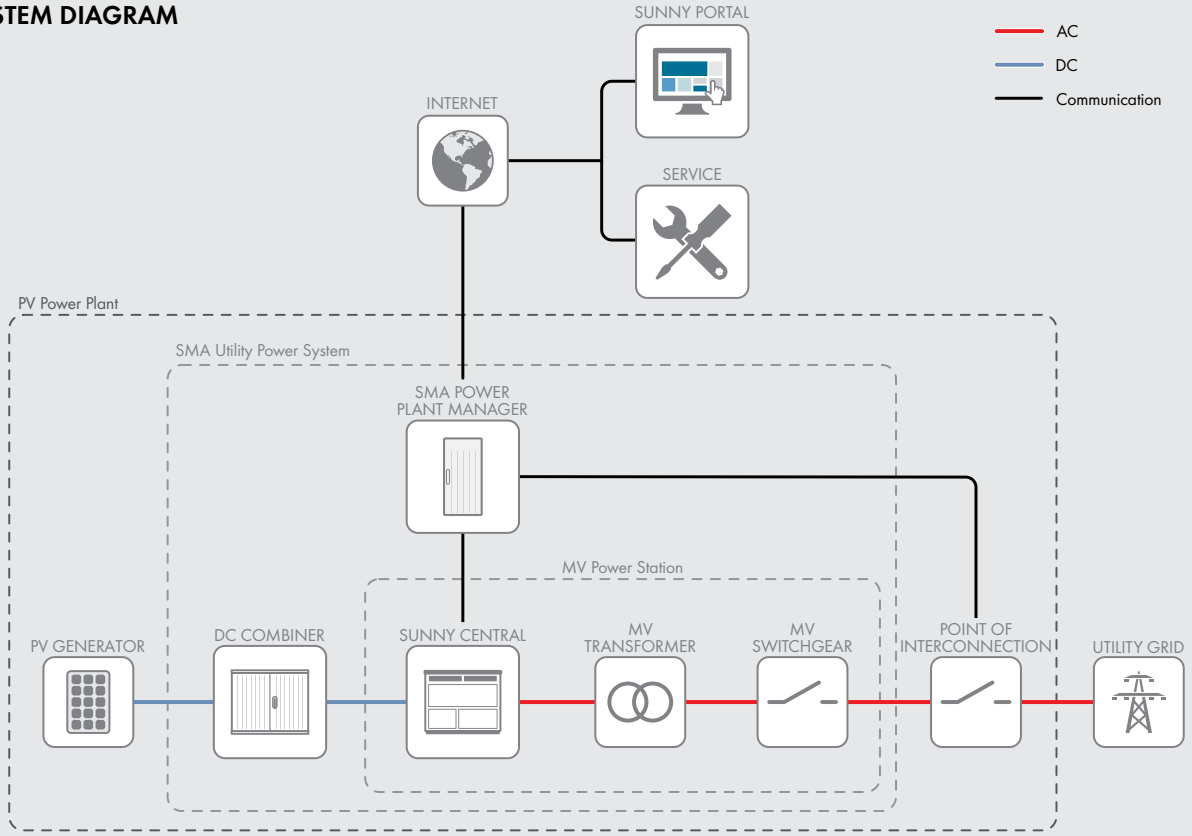

TEMPERATURE BEHAVIOR (at 1000 m)

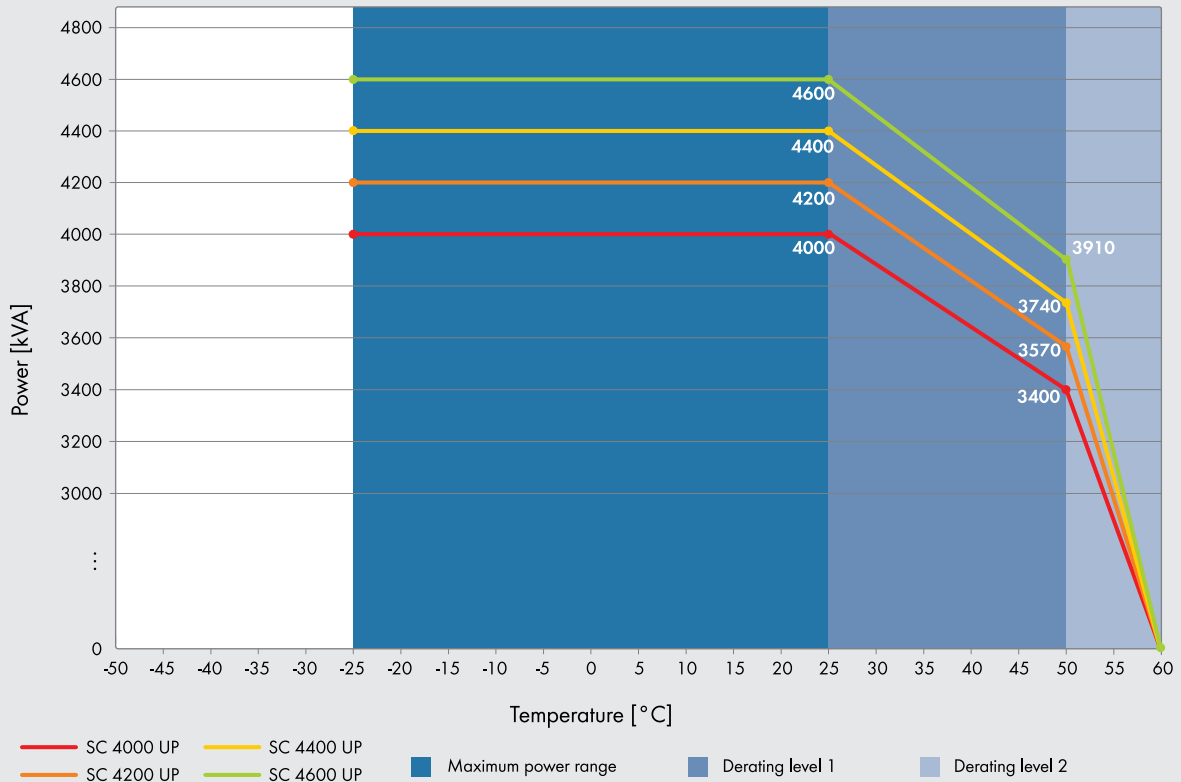



ALLEGATO 3: Pannelli fotovoltaici TRINA SOLAR DUOMAX TWIN DEG18MC.20(II)



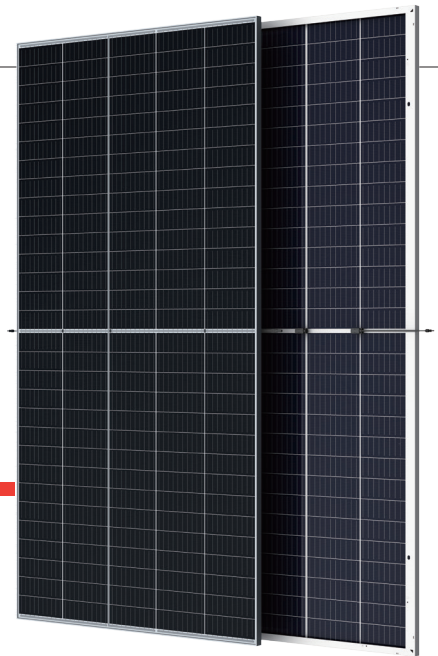

THE

DUOMAX twin

BIFACIAL DUAL GLASS MONOCRYSTALLINE MODULE

500W+
MAXIMUM POWER OUTPUT

21.0%
MAXIMUM EFFICIENCY

0~+5W
POSITIVE POWER TOLERANCE

PRODUCTS

TSM-DEG18MC.20(II)

POWER RANGE

485-505W



High power

- Up to 505W front power and 21.0% module efficiency with harmless cutting and MBB (Multi Busbar) technology
- Better light trapping effect and stronger current collection with lower series resistance of MBB ensure high power



High reliability

- Ensured PID resistance through cell process and module material control
- Resistant to salt, acid and ammonia
- Proven to be reliable in high temperature and humidity areas
- Certificated to fire class A
- Minimizes micro-crack and snail trails
- Certified to 5400 Pa positive load and 2400 Pa negative load



High energy generation

- Up to 25% additional power gain from back side depending on the albedo ;
- Excellent IAM and low light performance validated by 3rd party with cell process and module material optimization
- Lower temp coefficient (-0.35%) and NMOT bring more energy leading to lower LCOE
- Better anti-shading performance and lower operating temperature



High Customer value

- Frame design makes module compatible with all racking and installation methods
- Easy to handle and install as normal framed module during transportation
- High power and module Efficiency bring more BOS savings

Founded in 1997, Trina Solar is the world's leading total solution provider for solar energy. With local presence around the globe, Trina Solar is able to provide exceptional service to each customer in each market and deliver our innovative, reliable products with the backing of Trina as a strong, bankable brand. Trina Solar now distributes its PV products to over 100 countries all over the world. We are committed to building strategic, mutually beneficial collaborations with installers, developers, distributors and other partners in driving smart energy together.

Comprehensive Products and System Certificates

IEC61215/IEC61730/IEC61701/IEC62716
 ISO 9001: Quality Management System
 ISO 14001: Environmental Management System
 ISO14064: Greenhouse Gases Emissions Verification
 OHSAS 18001: Occupation Health and Safety Management System



Trina Solar's DUOMAX Performance Warranty

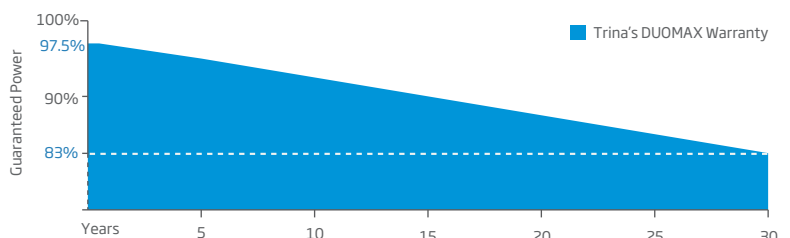

From the 2nd year to the 30th year, the average annual power decline will be no more than 0.5%.

DIMENSIONS OF PV MODULE(mm)

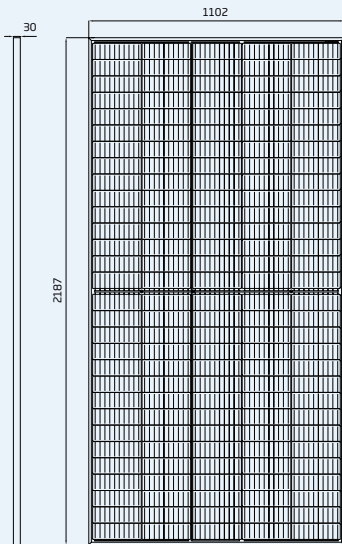

Front View

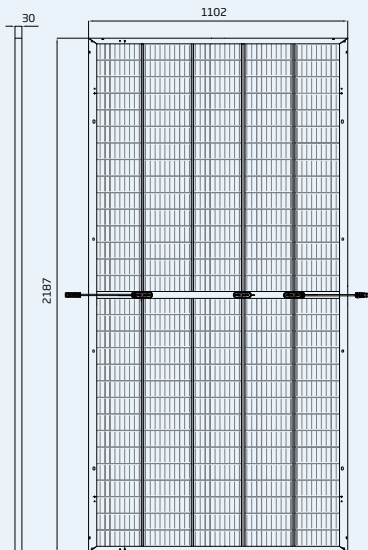

Back View

I-V CURVES OF PV MODULE(490W)

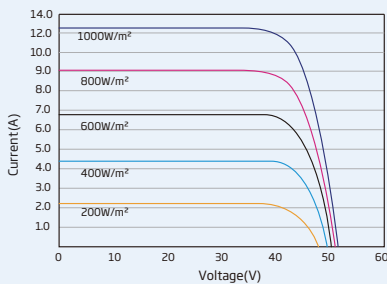

P-V CURVES OF PV MODULE(490W)

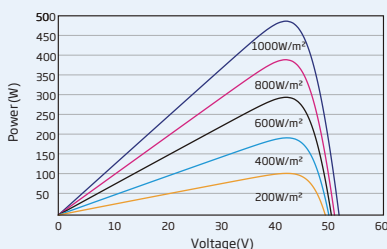

ELECTRICAL DATA (STC)

Peak Power Watts-P _{MAX} (Wp)*	485	490	495	500	505
Power Output Tolerance-P _{MAX} (W)			0 ~ +5		
Maximum Power Voltage-V _{MPP} (V)	42.5	42.8	43.1	43.4	43.7
Maximum Power Current-I _{MPP} (A)	11.42	11.45	11.49	11.53	11.56
Open Circuit Voltage-V _{OC} (V)	50.9	51.1	51.3	51.5	51.7
Short Circuit Current-I _{SC} (A)	12.01	12.05	12.09	12.13	12.17
Module Efficiency η _m (%)	20.1	20.3	20.5	20.7	21.0

STC: Irradiance 1000W/m², Cell Temperature 25°C, Air Mass AM1.5
*Measuring tolerance: ±3%.

Electrical characteristics with different power (reference to 100% Irradiance ratio)

Total Equivalent power -P _{MAX} (Wp)	519	524	530	535	540
Maximum Power Voltage-V _{MPP} (V)	42.5	42.8	43.1	43.4	43.7
Maximum Power Current-I _{MPP} (A)	12.22	12.24	12.29	12.34	12.37
Open Circuit Voltage-V _{OC} (V)	50.9	51.1	51.3	51.5	51.7
Short Circuit Current-I _{SC} (A)	12.85	12.89	12.94	12.98	13.02
Irradiance ratio (rear/front)			10%		

ELECTRICAL DATA (NMOT)

Maximum Power-P _{MAX} (Wp)	367	371	374	378	382
Maximum Power Voltage-V _{MPP} (V)	40.0	40.2	40.5	40.8	41.0
Maximum Power Current-I _{MPP} (A)	9.18	9.21	9.25	9.28	9.33
Open Circuit Voltage-V _{OC} (V)	48.1	48.3	48.5	48.7	48.8
Short Circuit Current-I _{SC} (A)	9.67	9.70	9.73	9.77	9.80

NMOT: Irradiance at 800W/m², Ambient Temperature 20°C, Wire Temperature 25°C

MECHANICAL DATA

Solar Cells	Monocrystalline
No. of cells	150 cells
Module Dimensions	2187×1102×30 mm (86.10×43.39×1.18 inches)
Weight	30.7 kg (67.7 lb)
Front Glass	2.0 mm (0.08 inches), High Transmission, AR Coated Heat Strengthened Glass
Encapsulant material	POE/EVA
Back Glass	2.0 mm (0.08 inches), Heat Strengthened Glass (White Grid Glass)
Frame	30mm(1.18 inches) Anodized Aluminium Alloy
J-Box	IP 68 rated
Cables	Photovoltaic Technology Cable 6.0mm ² (0.009 inches ²), Portrait: 280/280 mm(11.02/11.02 inches) Landscape: 2050/2050 mm(80.71/80.71 inches)
Connector	MC4 EVO2 / TS4*

*Please refer to regional datasheet for specified connector.

TEMPERATURE RATINGS

NMOT (Nominal Module Operating Temperature)	41°C (±3°C)
Temperature Coefficient of P _{MAX}	- 0.35%/°C
Temperature Coefficient of V _{OC}	- 0.25%/°C
Temperature Coefficient of I _{SC}	0.04%/°C

(Do not connect Fuse in Combiner Box with two or more strings in parallel connection)

MAXIMUM RATINGS

Operational Temperature	-40~+85°C
Maximum System Voltage	1500V DC (IEC) 1500V DC (UL)
Max Series Fuse Rating	20A

WARRANTY

- 12 year Product Workmanship Warranty
- 30 year Power Warranty

(Please refer to product warranty for details)

PACKAGING CONFIGURATION

Modules per 40' container: 670 pieces