

COMMITTENTE:



DIREZIONE LAVORI:



APPALTATORE:



MANDATARIA

MANDANTI

PROGETTAZIONE:

MANDATARIA



MANDANTI



PROGETTO ESECUTIVO

LINEA PESCARA - BARI RADDOPPIO DELLA TRATTA FERROVIARIA TERMOLI - LESINA LOTTO 1: RIPALTA - LESINA

P.M. RIPALTA

Tabella Mensole fase 1

APPALTATORE CONPAT S.c.a.r.l. DIRETTORE TECNICO Il Direttore Tecnico (Ing. Gianguido Babini)	PROGETTAZIONE DIRETTORE DELLA PROGETTAZIONE Ing. M. Di Girolamo PROFESSIONALE	SCALA: -
---	--	-----------------

COMMESSA LOTTO FASE ENTE TIPO DOC. OPERA/DISCIPLINA PROGR. REV.

L I 0 7 0 1 E Z Z P A L C 0 1 0 0 0 0 1 B

Revis.	Descrizione	Redatto	Data	Verificato	Data	Approvato	Data	Autorizzato Data
A	Emissione Esecutiva	A. Falasca	Ottobre 2021	G.Filippucci	Ottobre 2021	F.Nicchiarelli	Ottobre 2021	M. Di Girolamo Aprile 2022
B	Emissione A Seguito RDV	A. Falasca	Aprile 2022	G.Filippucci	Aprile 2022	F.Nicchiarelli	Aprile 2021	

File: LI0701EZZPALC0100001B.DWG

n. Elab.:

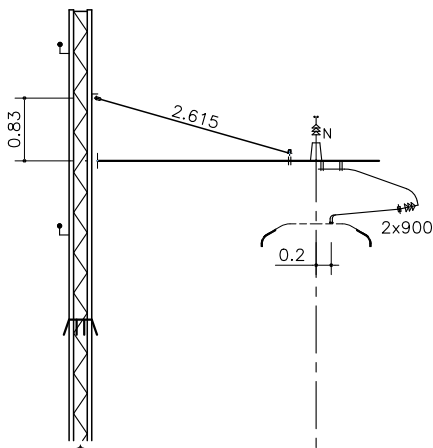

B0a

HFC=5.2 m d=-0.3 m

BC H=0
DR=2.25

N° SOSTEGNO

135

SOSTEGNO

LSU14A

LUNGHEZZA
MENSOLE
TIRANTI

Mensola=3.8
Tirante=2.615

CAT./PROG.
SOSPENSIONI

SCALA 1:100

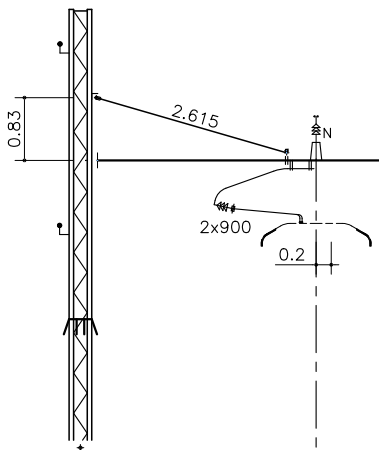

B0a

HFC=5.2 m d=-0.3 m

BC H=0
DR=2.25

N° SOSTEGNO

136

SOSTEGNO

LSU14A

LUNGHEZZA
MENSOLE
TIRANTI

Mensola=3.8
Tirante=2.615

CAT./PROG.
SOSPENSIONI

SCALA 1:100

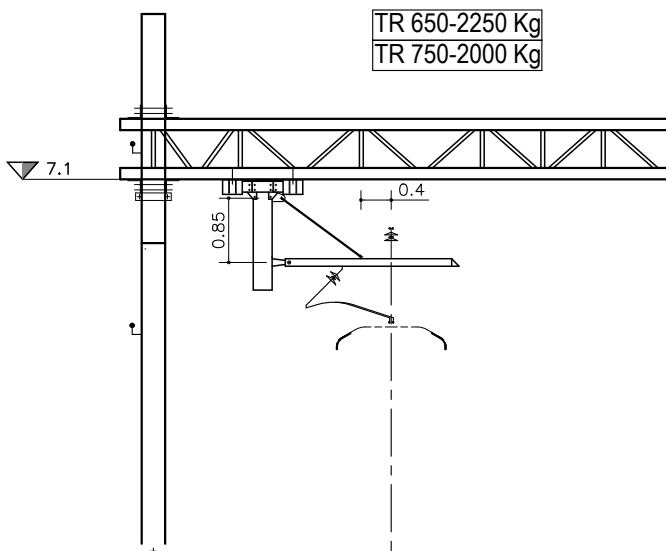

PT2

HFC=5.2 m d=-0.3 m

BC H=0
DR=2.27

N° SOSTEGNO

1

SOSTEGNO

POT 2B

LUNGHEZZA
MENSOLE
TIRANTI

Mensola=2.20
Tirante=1.3

CAT./PROG.
SOSPENSIONI

773/903

SCALA 1:100

H PILONE=9.586 m

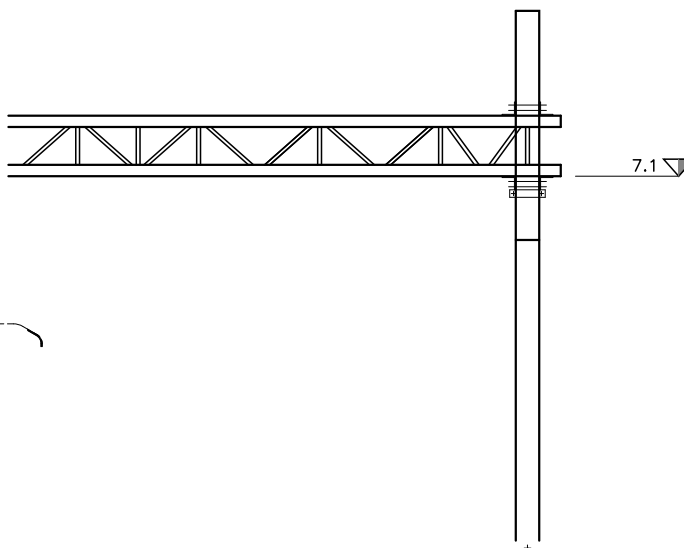

PT2

HFC=5.2 m

d=-0.3 m

BC H=0
DR=6.27

H PILONE=9.586 m

N° SOSTEGNO

2

SOSTEGNO

POT 2B

LUNGHEZZA
MENSOLE
TIRANTI

CAT./PROG.
SOSPENSIONI

SCALA 1:100

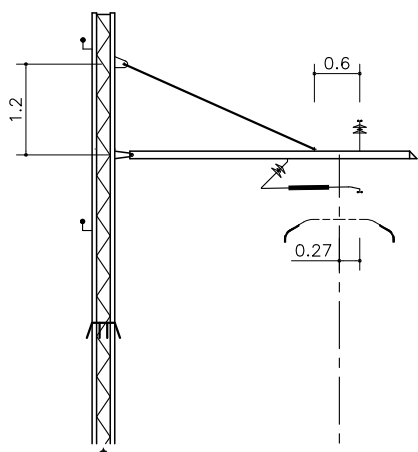

B0a

HFC=5.2 m

d=-0.4 m

BC H=0
DR=2.25

N° SOSTEGNO

3

SOSTEGNO

LSU14A

LUNGHEZZA
MENSOLE
TIRANTI

Mensola=3.70

Tirante=2.8

CAT./PROG.
SOSPENSIONI

773/916

SCALA 1:100

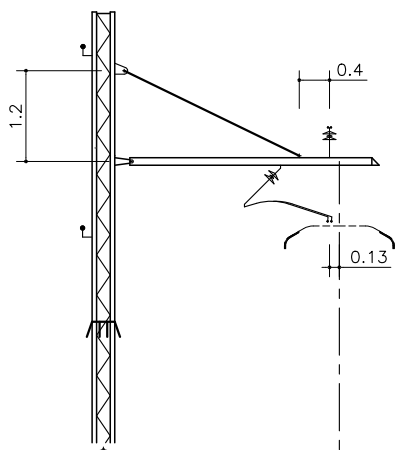

B0a

HFC=5.2 m

d=-0.3 m

BC H=0
DR=2.25

N° SOSTEGNO

5

SOSTEGNO

LSU14A

LUNGHEZZA
MENSOLE
TIRANTI

Mensola=3.20

Tirante=2.6

CAT./PROG.
SOSPENSIONI

773/788

SCALA 1:100

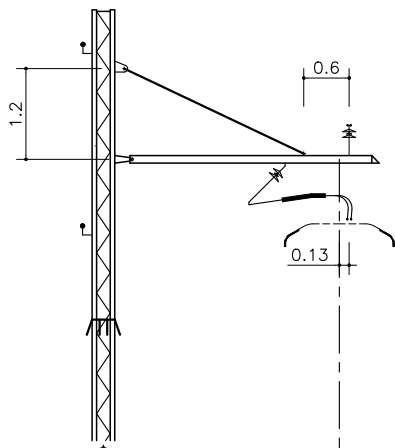

B0a

HFC=5.2 m d=-0.3 m

BC H=0
DR=2.25

N° SOSTEGNO

7

SOSTEGNO

LSU14A

LUNGHEZZA
MENSOLE
TIRANTI

Mensola=3.20
Tirante=2.6

CAT./PROG.
SOSPENSIONI

773/793

SCALA 1:100

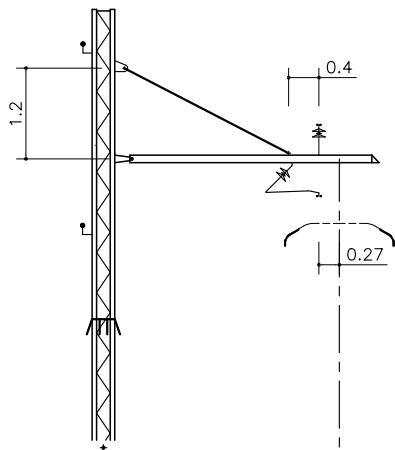

B0a

HFC=5.2 m d=-0.3 m

BC H=0
DR=2.25

N° SOSTEGNO

9

SOSTEGNO

LSU14A

LUNGHEZZA
MENSOLE
TIRANTI

Mensola=3.20
Tirante=2.4

CAT./PROG.
SOSPENSIONI

773/789

SCALA 1:100

DISCESA DI ALIMENTAZIONE
SULLA CONDUTTURA DI TRATTA

n.2 Corde 2x230 mm²

TR 650-2250 Kg
TR 750-2000 Kg

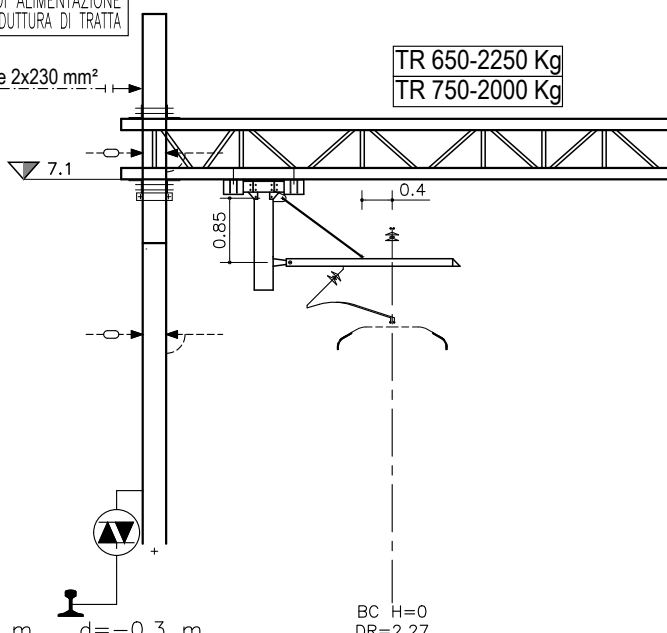

PT2

HFC=5.2 m d=-0.3 m

BC H=0
DR=2.27

N° SOSTEGNO

11

SOSTEGNO

POT 2B

LUNGHEZZA
MENSOLE
TIRANTI

Mensola=2.20
Tirante=1.3

CAT./PROG.
SOSPENSIONI

773/903

SCALA 1:100

H PILONE=9.586 m

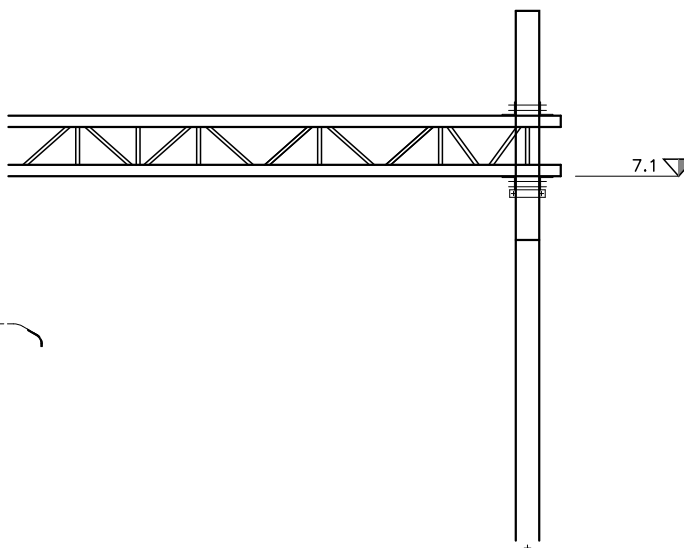

PT2

HFC=5.2 m

d=-0.3 m

BC H=0
DR=6.27

H PILONE=9.586 m

N° SOSTEGNO

12

SOSTEGNO

POT 2B

LUNGHEZZA
MENSOLE
TIRANTI

CAT./PROG.
SOSPENSIONI

SCALA 1:100

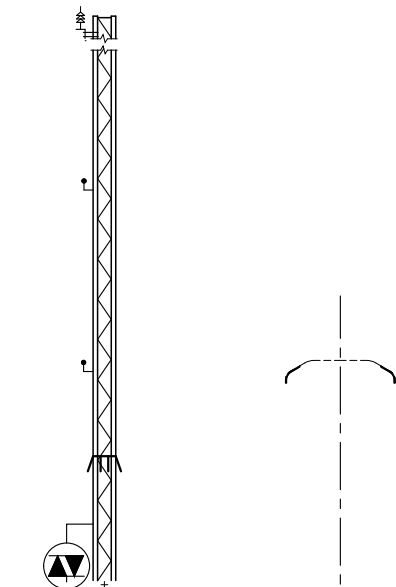

B1

HFC=5.2 m

d=-0.3 m

BP H=0
DR=2.25

N° SOSTEGNO

21/A

SOSTEGNO

LSU14C

LUNGHEZZA
MENSOLE
TIRANTI

CAT./PROG.
SOSPENSIONI

SCALA 1:100

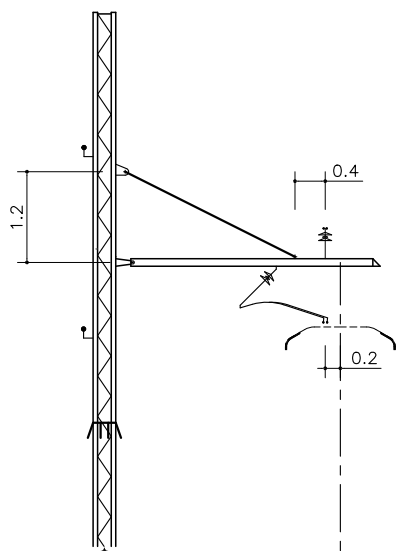

B0a

HFC=5.2 m

d=-0.3 m

BC H=0
DR=2.25

N° SOSTEGNO

13

SOSTEGNO

LSU14B

LUNGHEZZA
MENSOLE
TIRANTI

Mensola=3.20
Tirante=2.5

CAT./PROG.
SOSPENSIONI

773/788

SCALA 1:100

TABELLA MENSOLE
Schema di montaggio

Stazione di

PM RIPALTA

Pagina

6

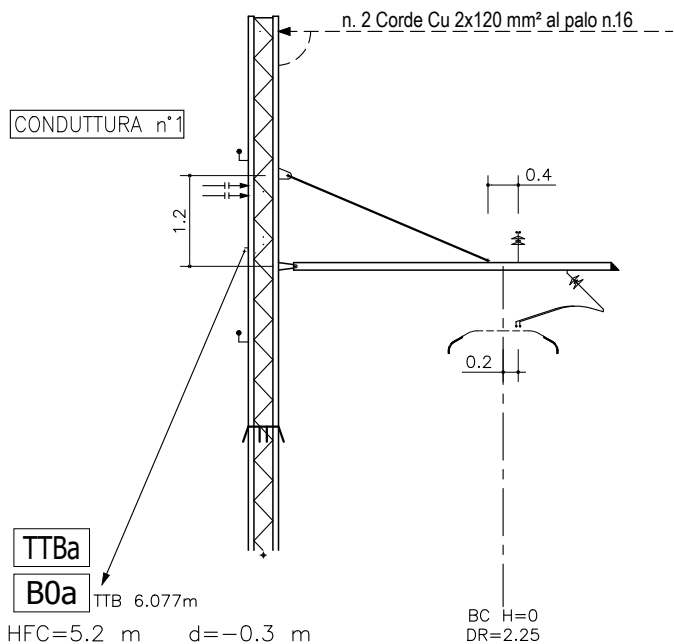

N° SOSTEGNO

15

SOSTEGNO

LSU20B

LUNGHEZZA
MENSOLE
TIRANTI

Mensola=4.20
Tirante=2.9

CAT./PROG.
SOSPENSIONI

773/669

SCALA 1:100

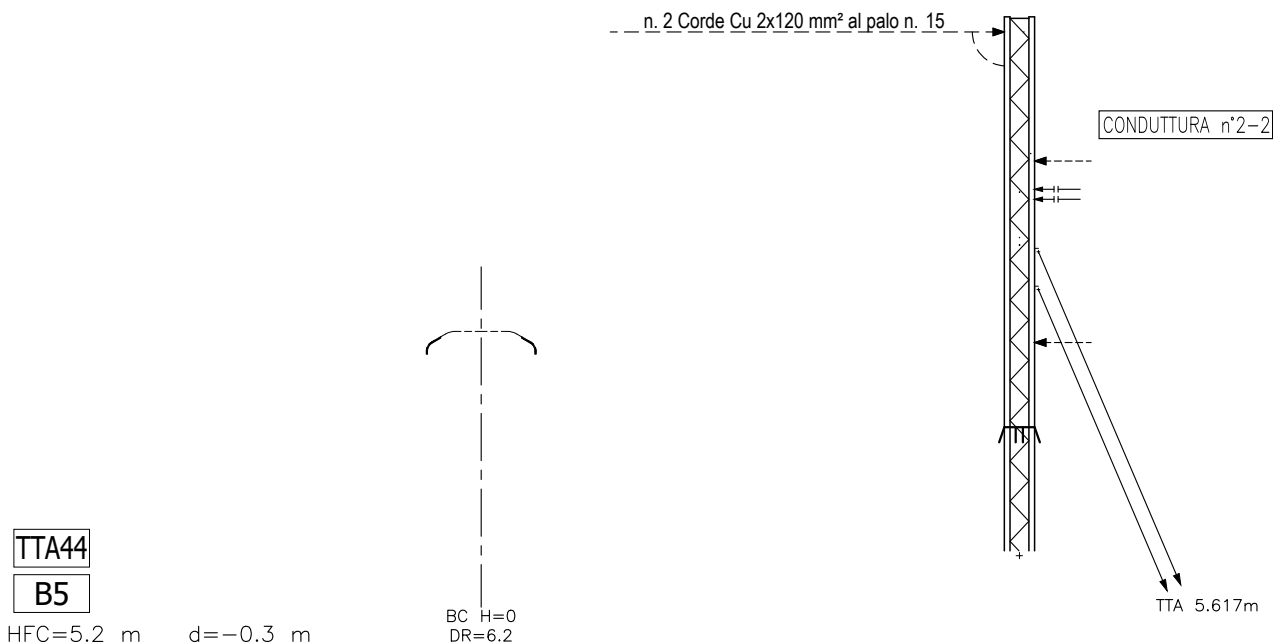

N° SOSTEGNO

16

SOSTEGNO

LSU20B

LUNGHEZZA
MENSOLE
TIRANTI

CAT./PROG.
SOSPENSIONI

SCALA 1:100

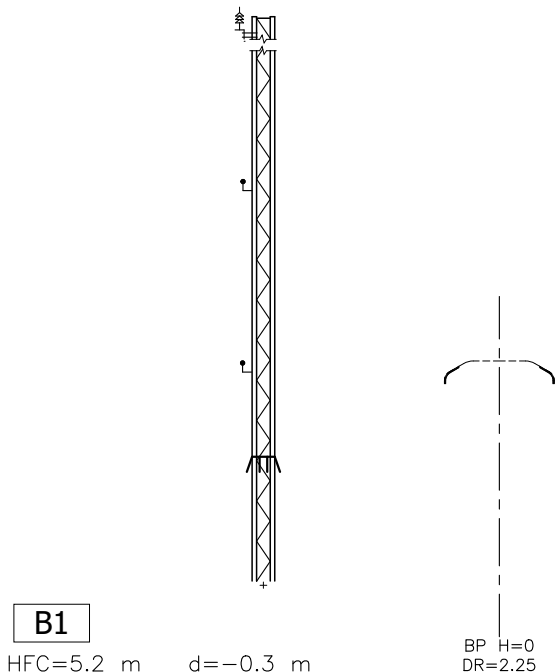

N° SOSTEGNO

19/A

SOSTEGNO

LSU14C

LUNGHEZZA
MENSOLE
TIRANTI

CAT./PROG.
SOSPENSIONI

SCALA 1:100

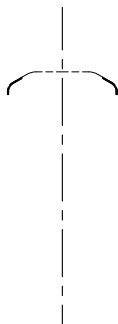
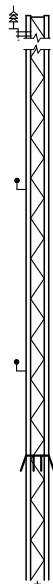

BP H=0
DR=2.25

B1

HFC=5.2 m d=-0.3 m

N° SOSTEGNO

17/A

SOSTEGNO

LSU14C

LUNGHEZZA
MENSOLE
TIRANTI

CAT./PROG.
SOSPENSIONI

SCALA 1:100

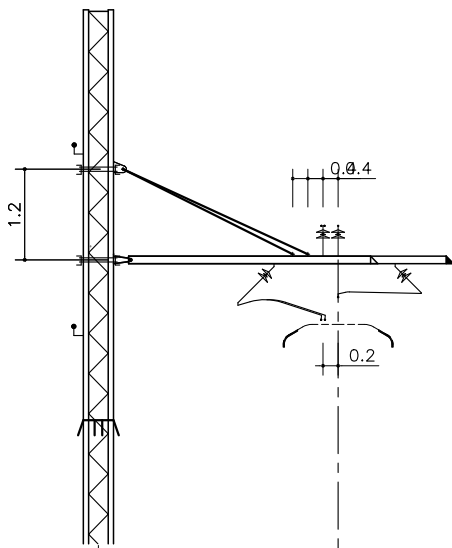

Vista in pianta

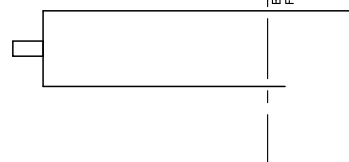

Fila Conca
Fusili Servizio

FS
2.97
BC H=0
DR=2.25

P6

HFC=5.2 m d=-0.3 m

N° SOSTEGNO

17

SOSTEGNO

LSU18B

LUNGHEZZA
MENSOLE
TIRANTI

Mensola=3.20

Tirante=2.4

Mensola=4.20

Tirante=2.6

CAT./PROG.
SOSPENSIONI

773/937

773/788

SCALA 1:100

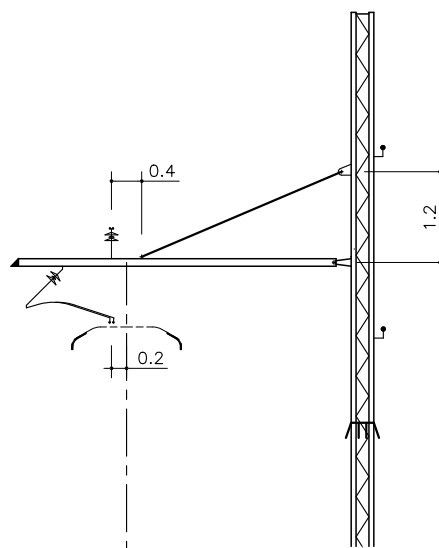

B2

HFC=5.2 m d=-0.3 m

BC H=0
DR=2.25

N° SOSTEGNO

18

SOSTEGNO

LSU16B

LUNGHEZZA
MENSOLE
TIRANTI

Mensola=4.20

Tirante=2.9

CAT./PROG.
SOSPENSIONI

773/669

SCALA 1:100

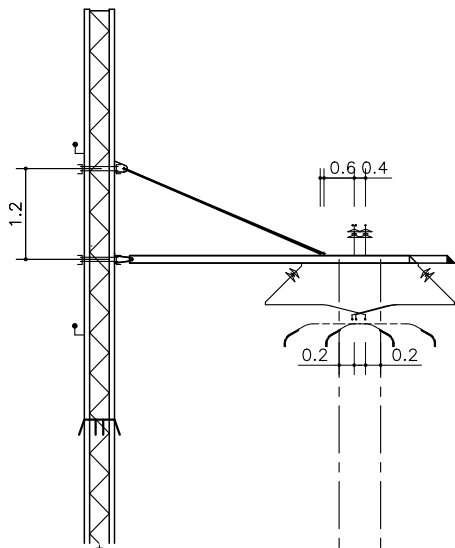

P6

HFC=5.2 m d=-0.3 m

BC H=0
DR=2.8

N° SOSTEGNO

19

SOSTEGNO

LSU18B

LUNGHEZZA
MENSOLE
TIRANTI

Mensola=4.20

Tirante=2.9

Mensola=3.70

Tirante=2.8

CAT./PROG.
SOSPENSIONI

773/797

773/991

SCALA 1:100

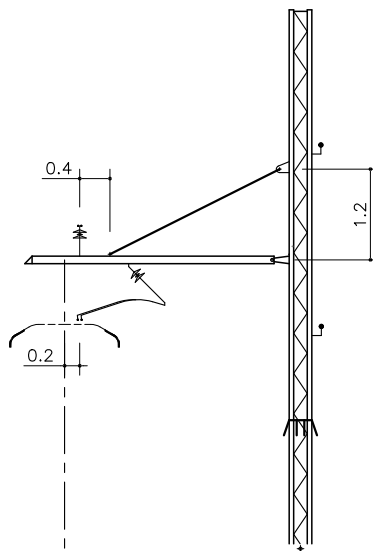

B1

HFC=5.2 m d=-0.3 m

BC H=0
DR=2.25

N° SOSTEGNO

20

SOSTEGNO

LSU14B

LUNGHEZZA
MENSOLE
TIRANTI

Mensola=3.20

Tirante=2.5

CAT./PROG.
SOSPENSIONI

773/788

SCALA 1:100

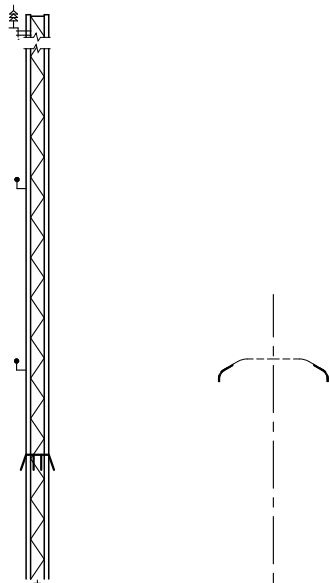

B1

HFC=5.2 m d=-0.3 m

BP H=0
DR=2.25

N° SOSTEGNO

15/A

SOSTEGNO

LSU14C

LUNGHEZZA
MENSOLE
TIRANTI

CAT./PROG.
SOSPENSIONI

SCALA 1:100

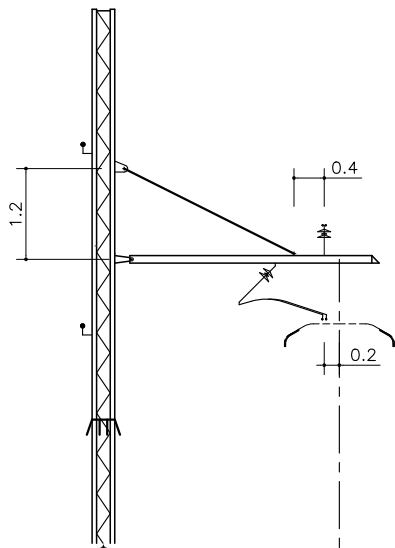

B0a

HFC=5.2 m d=-0.3 m

BC H=0
DR=2.25

N° SOSTEGNO

21

SOSTEGNO

LSU14B

LUNGHEZZA
MENSOLE
TIRANTI

Mensola=3.20
Tirante=2.5

CAT./PROG.
SOSPENSIONI

773/788

SCALA 1:100

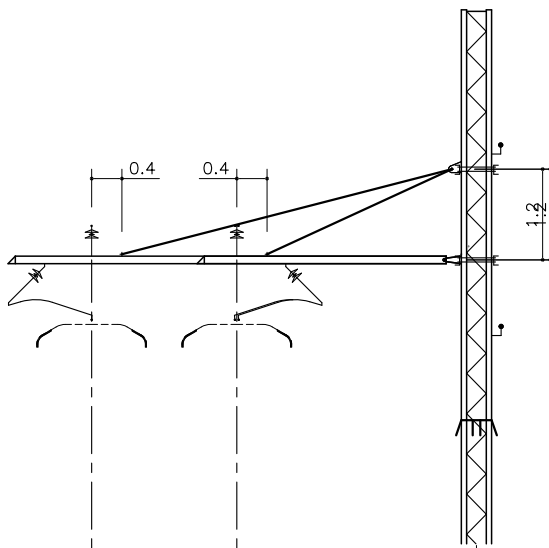

P5

HFC=5.2 m d=-0.3 m

BS H=0
DR=4.17

BC H=0
DR=2.25

N° SOSTEGNO

22

SOSTEGNO

LSU18B

LUNGHEZZA
MENSOLE
TIRANTI

Mensola=3.20
Tirante=2.5
Mensola=3.20
Tirante=2.7
Mensola=5.70
Tirante=4.5

CAT./PROG.
SOSPENSIONI

773/755

773/788

SCALA 1:100

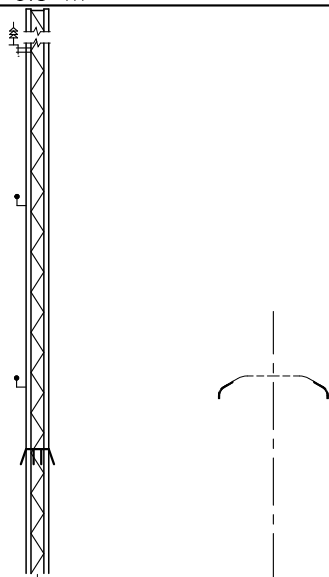

B1

HFC=5.2 m d=-0.3 m

BP H=0
DR=2.25

N° SOSTEGNO

13/A

SOSTEGNO

LSU16C

LUNGHEZZA
MENSOLE
TIRANTI

CAT./PROG.
SOSPENSIONI

SCALA 1:100

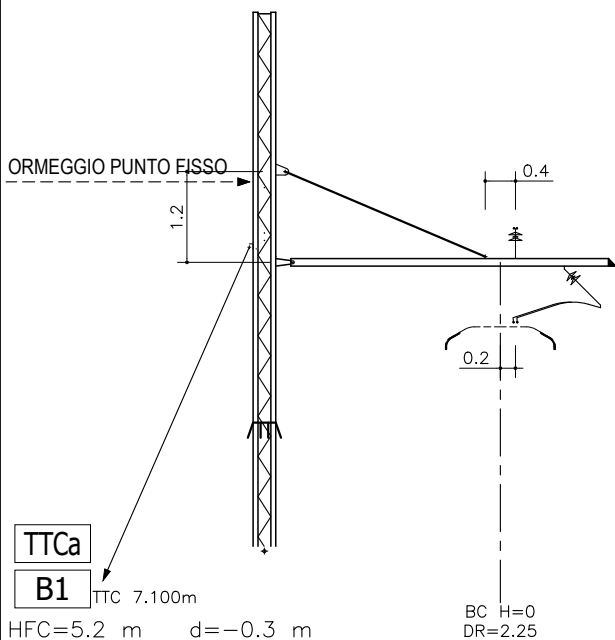

N° SOSTEGNO

23

SOSTEGNO

LSU16B

LUNGHEZZA
MENSOLE
TIRANTI

Mensola=4.20
Tirante=2.9

CAT./PROG.
SOSPENSIONI

773/669

SCALA 1:100

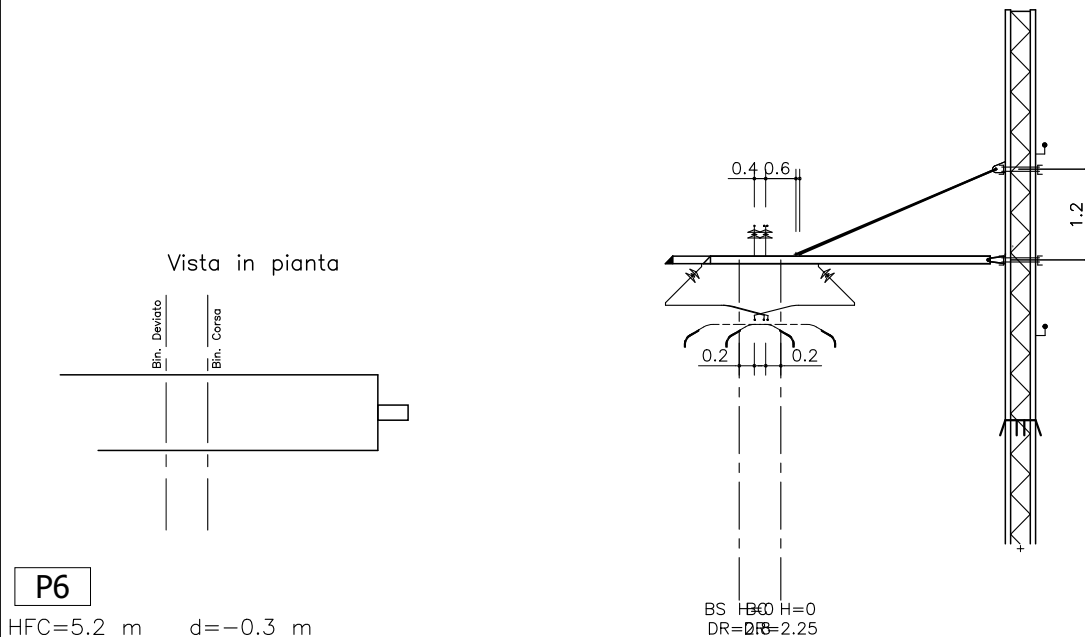

N° SOSTEGNO

24

SOSTEGNO

LSU18B

LUNGHEZZA
MENSOLE
TIRANTI

Mensola=4.20
Tirante=2.9
Mensola=3.70
Tirante=2.8

CAT./PROG.
SOSPENSIONI

773/797

773/991

SCALA 1:100

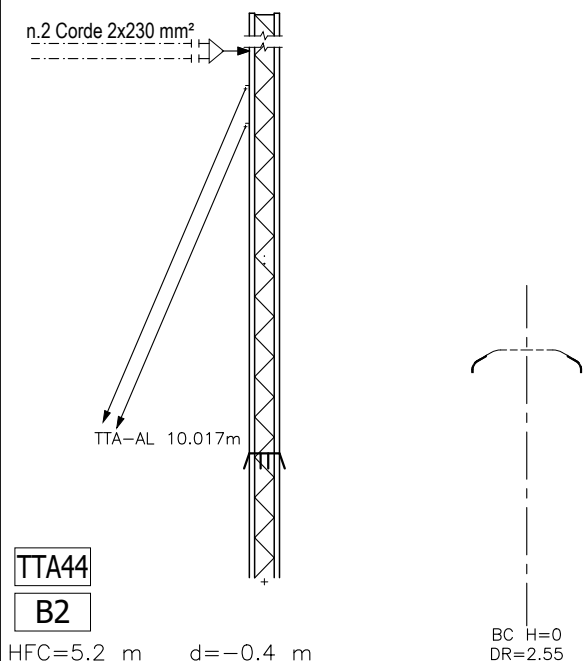

N° SOSTEGNO

11/A

SOSTEGNO

LSU18C

LUNGHEZZA
MENSOLE
TIRANTI

CAT./PROG.
SOSPENSIONI

SCALA 1:100

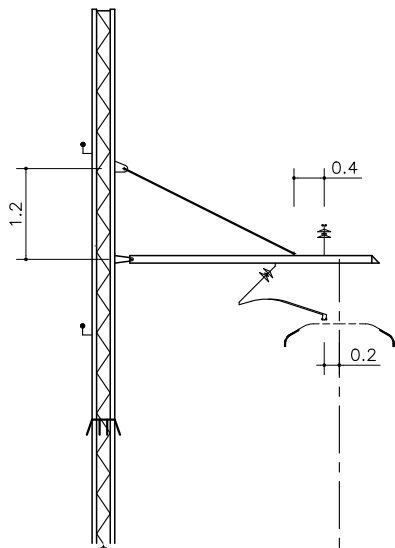

B0a

HFC=5.2 m d=-0.3 m

BC H=0
DR=2.25

N° SOSTEGNO

25

SOSTEGNO

LSU14B

LUNGHEZZA
MENSOLE
TIRANTI

Mensola=3.20

Tirante=2.5

CAT./PROG.
SOSPENSIONI

773/788

SCALA

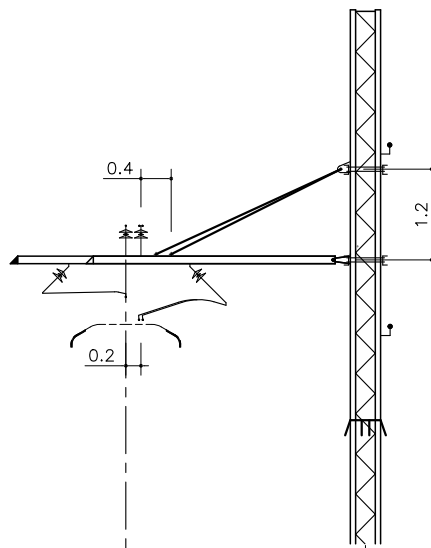

P6

HFC=5.2 m d=-0.3 m

FS
2.97
BC H=0
DR=2.25

N° SOSTEGNO

26

SOSTEGNO

LSU18B

LUNGHEZZA
MENSOLE
TIRANTI

Mensola=3.20

Tirante=2.4

Mensola=4.2

Tirante=2.7

CAT./PROG.
SOSPENSIONI

773/937

773/788

SCALA 1:100

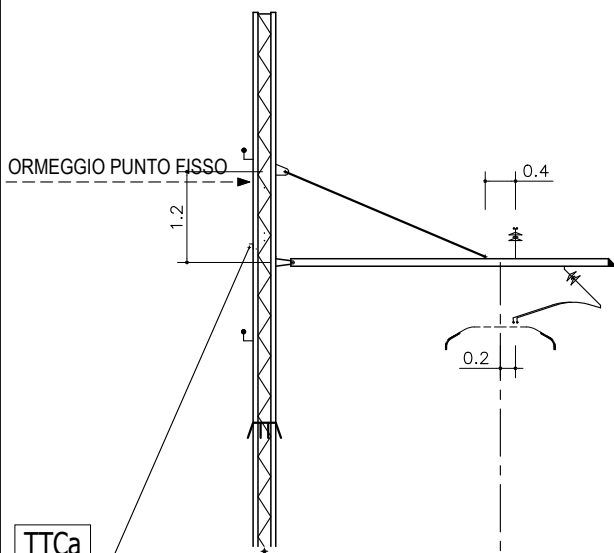

TTCa

B1

IITC 7.100m

HFC=5.2 m d=-0.3 m

BC H=0
DR=2.25

N° SOSTEGNO

27

SOSTEGNO

LSU16B

LUNGHEZZA
MENSOLE
TIRANTI

Mensola=4.20

Tirante=2.9

CAT./PROG.
SOSPENSIONI

773/669

SCALA 1:100

TTBa

P6

HFC=5.2 m d=-0.3 m

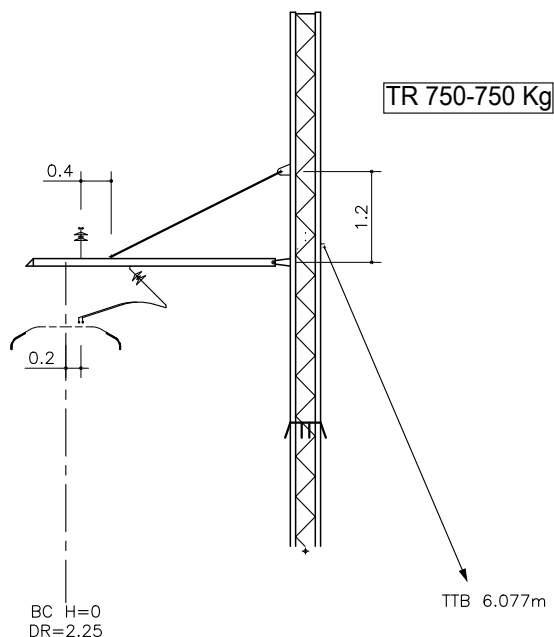

N° SOSTEGNO

28

SOSTEGNO

LSU18B

LUNGHEZZA
MENSOLE
TIRANTI

Mensola=3.20
Tirante=2.5

CAT./PROG.
SOSPENSIONI

773/788

SCALA 1:100

n.2 Corde 2x230 mm²

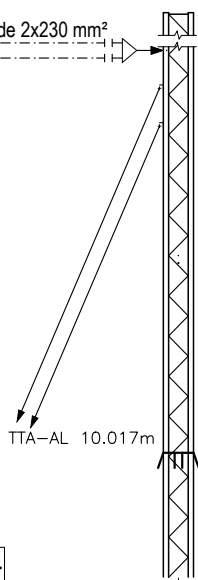

BC H=0
DR=2.55

TTA44

B2

HFC=5.2 m d=-0.4 m

N° SOSTEGNO

9/A

SOSTEGNO

LSU18C

LUNGHEZZA
MENSOLE
TIRANTI

CAT./PROG.
SOSPENSIONI

SCALA 1:100

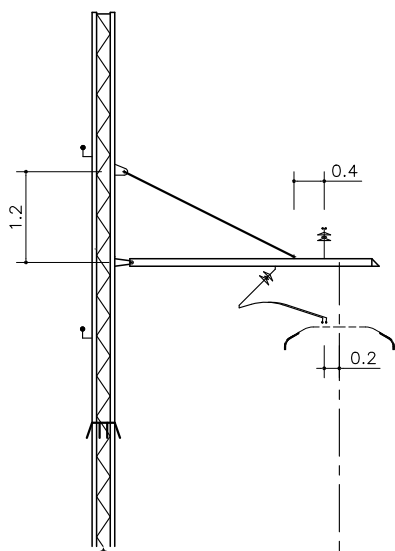

BC H=0
DR=2.25

B0a

HFC=5.2 m d=-0.3 m

N° SOSTEGNO

29

SOSTEGNO

LSU14B

LUNGHEZZA
MENSOLE
TIRANTI

Mensola=3.20
Tirante=2.5

CAT./PROG.
SOSPENSIONI

773/788

SCALA 1:100

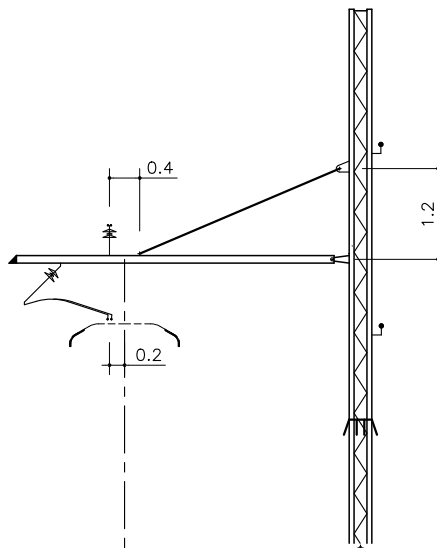

BC H=0
DR=2.25

B1

HFC=5.2 m d=-0.3 m

N° SOSTEGNO

30

SOSTEGNO

LSU16B

LUNGHEZZA
MENSOLE
TIRANTI

Mensola=4.20
Tirante=2.9

CAT./PROG.
SOSPENSIONI

773/669

SCALA 1:100

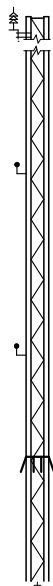

BC H=0
DR=2.25

B1

HFC=5.2 m d=-0.4 m

N° SOSTEGNO

7/A

SOSTEGNO

LSU16C

LUNGHEZZA
MENSOLE
TIRANTI

CAT./PROG.
SOSPENSIONI

SCALA 1:100

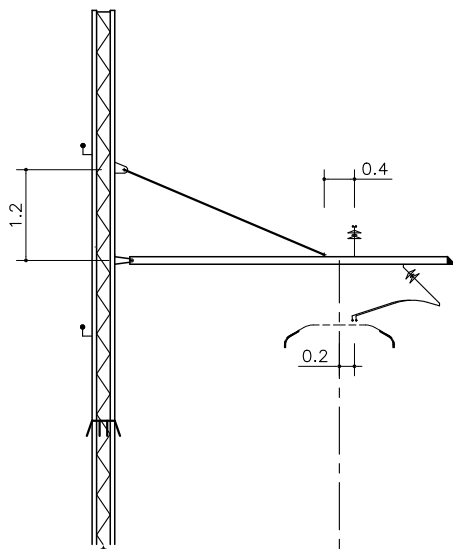

BC H=0
DR=2.25

B0a

HFC=5.2 m d=-0.3 m

N° SOSTEGNO

31

SOSTEGNO

LSU14B

LUNGHEZZA
MENSOLE
TIRANTI

Mensola=4.20
Tirante=2.9

CAT./PROG.
SOSPENSIONI

773/669

SCALA 1:100

N° SOSTEGNO

32

SOSTEGNO

LSU16B

LUNGHEZZA
MENSOLE
TIRANTI

Mensola=3.20
Tirante=2.5

CAT./PROG.
SOSPENSIONI

773/788

SCALA 1:100

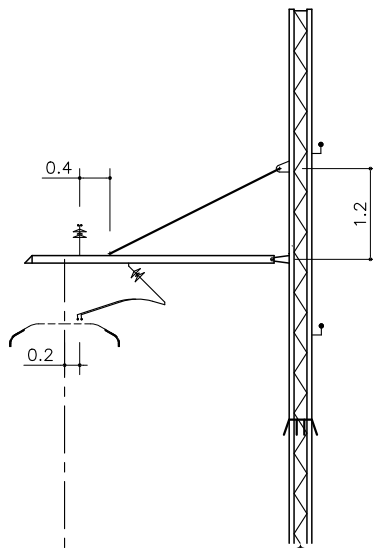

B1

HFC=5.2 m d=-0.3 m

BC H=0
DR=2.25

N° SOSTEGNO

5/A

SOSTEGNO

LSU16C

LUNGHEZZA
MENSOLE
TIRANTI

CAT./PROG.
SOSPENSIONI

SCALA 1:100

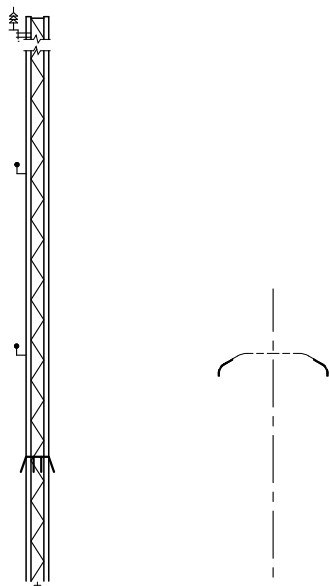

B1

HFC=5.2 m d=-0.4 m

BC H=0
DR=2.25

N° SOSTEGNO

33

SOSTEGNO

LSU14B

LUNGHEZZA
MENSOLE
TIRANTI

Mensola=3.20
Tirante=2.5

CAT./PROG.
SOSPENSIONI

773/788

SCALA 1:100

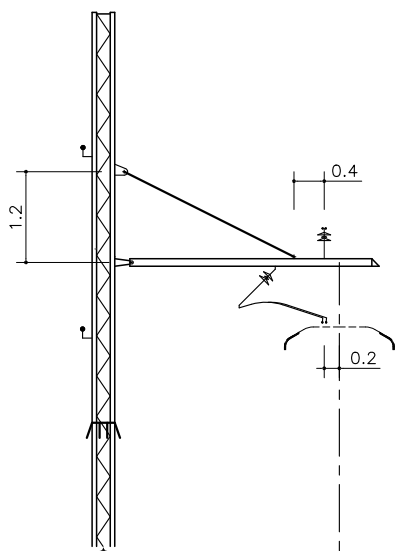

B0a

HFC=5.2 m d=-0.3 m

BC H=0
DR=2.25

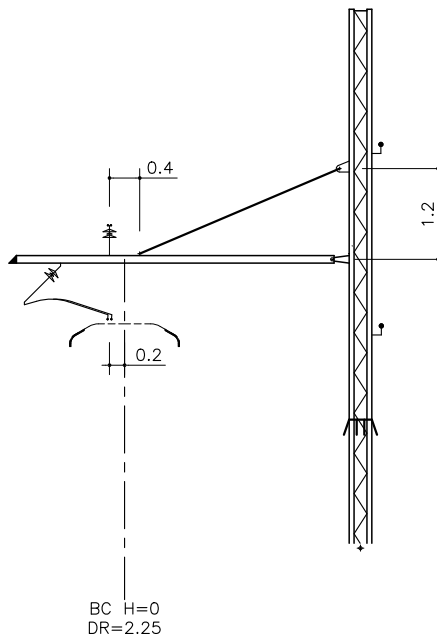

B1
HFC=5.2 m d=-0.3 m

N° SOSTEGNO
34
SOSTEGNO
LSU16B
LUNGHEZZA MENSOLE TIRANTI
Mensola=4.20 Tirante=2.9
CAT./PROG. SOSPENSIONI
773/669
SCALA 1:100

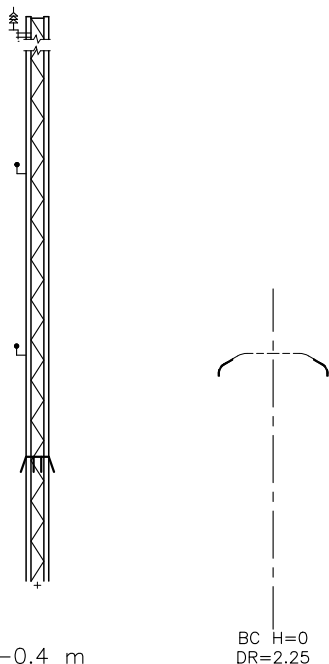

B1
HFC=5.2 m d=-0.4 m

N° SOSTEGNO
3/A
SOSTEGNO
LSU16C
LUNGHEZZA MENSOLE TIRANTI
CAT./PROG. SOSPENSIONI
SCALA 1:100

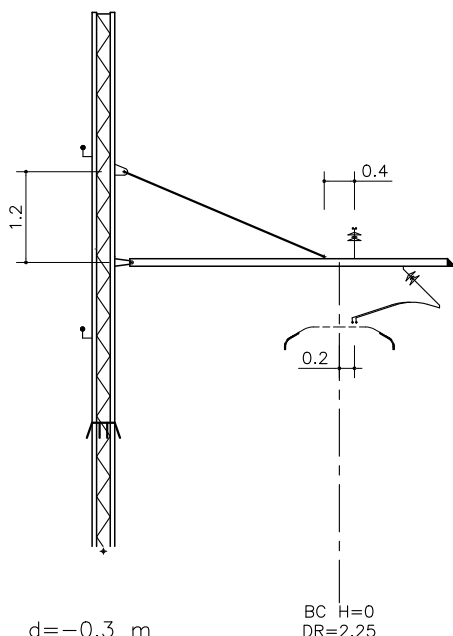

B0a
HFC=5.2 m d=-0.3 m

N° SOSTEGNO
35
SOSTEGNO
LSU14B
LUNGHEZZA MENSOLE TIRANTI
Mensola=4.20 Tirante=2.9
CAT./PROG. SOSPENSIONI
773/669
SCALA 1:100

N° SOSTEGNO

36

SOSTEGNO

LSU16B

LUNGHEZZA
MENSOLE
TIRANTI

Mensola=3.20
Tirante=2.5

CAT./PROG.
SOSPENSIONI

773/788

SCALA 1:100

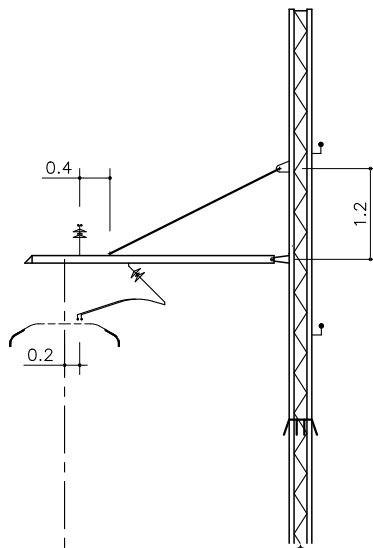

BC H=0
DR=2.25

B1

HFC=5.2 m d=-0.3 m

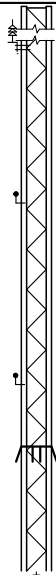

N° SOSTEGNO

2/A

SOSTEGNO

LSU18C

LUNGHEZZA
MENSOLE
TIRANTI

CAT./PROG.
SOSPENSIONI

SCALA 1:100

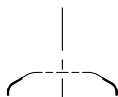

BP H=0
DR=2.25

B1

HFC=5.2 m d=-0.3 m

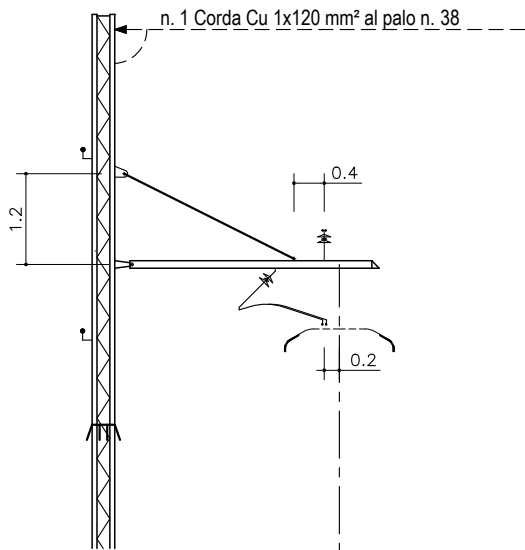

BC H=0
DR=2.25

B3a

HFC=5.2 m d=-0.3 m

N° SOSTEGNO

37

SOSTEGNO

LSU16B

LUNGHEZZA
MENSOLE
TIRANTI

Mensola=3.20
Tirante=2.5

CAT./PROG.
SOSPENSIONI

773/788

SCALA 1:100

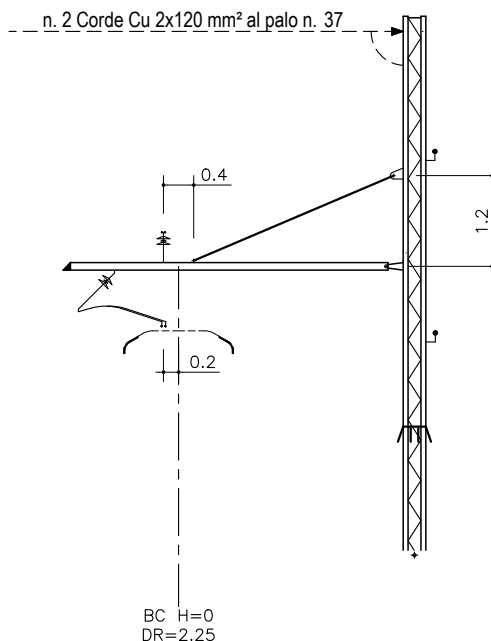

B3a

HFC=5.2 m d=-0.3 m

N° SOSTEGNO

38

SOSTEGNO

LSU16B

LUNGHEZZA
MENSOLE
TIRANTI

Mensola=4.20
Tirante=2.9

CAT./PROG.
SOSPENSIONI

773/669

SCALA 1:100

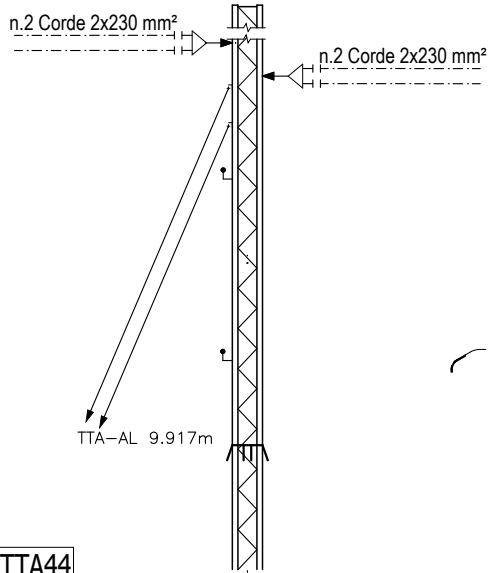

TTA44

B4

HFC=5.2 m d=-0.3 m

N° SOSTEGNO

1/A

SOSTEGNO

LSU20C

LUNGHEZZA
MENSOLE
TIRANTI

CAT./PROG.
SOSPENSIONI

SCALA 1:100

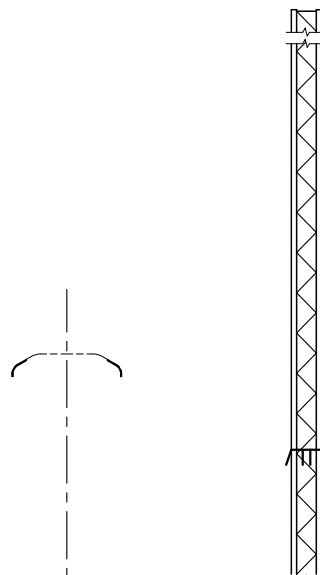

B3

HFC=5.2 m d=-0.3 m

N° SOSTEGNO

4/A

SOSTEGNO

LSU18C

LUNGHEZZA
MENSOLE
TIRANTI

CAT./PROG.
SOSPENSIONI

SCALA 1:100

B3

HFC=5.2 m d=-0.3 m

BC H=0
DR=2.25

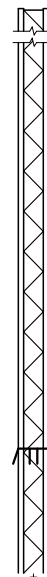

N° SOSTEGNO

2/2A

SOSTEGNO

LSU18C

LUNGHEZZA
MENSOLE
TIRANTI

CAT./PROG.
SOSPENSIONI

SCALA

PT2

HFC=5.2 m d=-0.3 m

BC H=0
DR=2.27

H PILONE=9.586 m

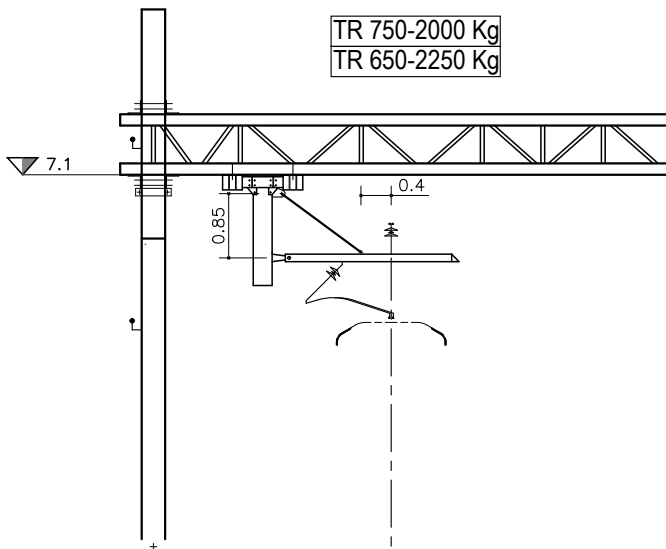

N° SOSTEGNO

39

SOSTEGNO

POT 2B

LUNGHEZZA
MENSOLE
TIRANTI

Mensola=2.20

Tirante=1.3

CAT./PROG.
SOSPENSIONI

773/903

SCALA 1:100

PT2

HFC=5.2 m d=-0.3 m

BC H=0
DR=2.25

H PILONE=9.586 m

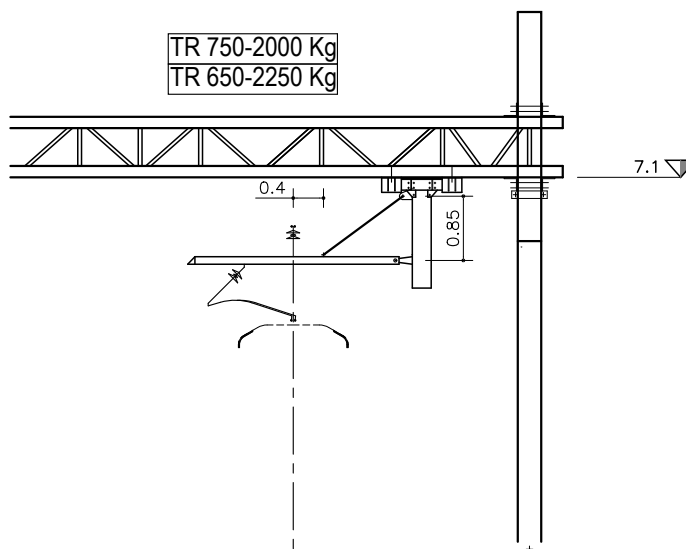

N° SOSTEGNO

40

SOSTEGNO

POT 2B

LUNGHEZZA
MENSOLE
TIRANTI

Mensola=2.70

Tirante=1.3

CAT./PROG.
SOSPENSIONI

773/664

SCALA 1:100

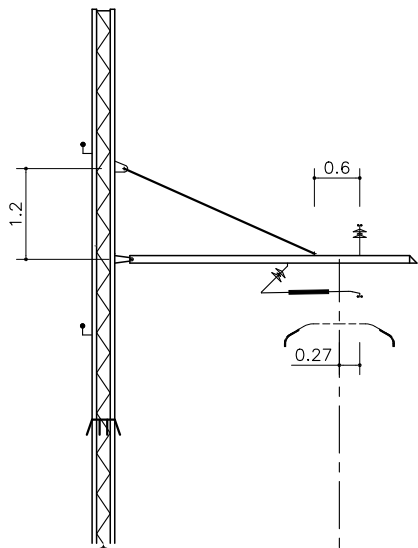

B0a

HFC=5.2 m d=-0.3 m

BC H=0
DR=2.25

N° SOSTEGNO

41

SOSTEGNO

LSU14B

LUNGHEZZA
MENSOLE
TIRANTI

Mensola=3.70
Tirante=2.8

CAT./PROG.
SOSPENSIONI

773/916

SCALA 1:100

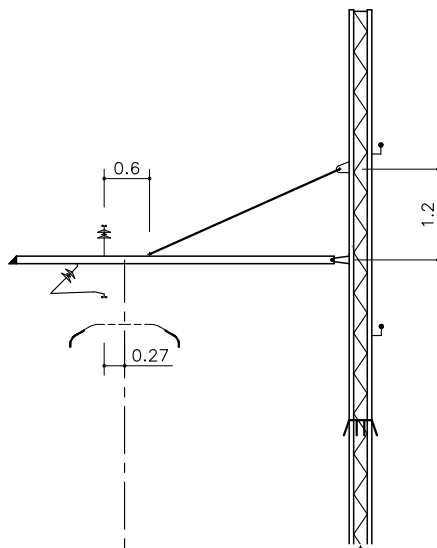

B0a

HFC=5.2 m d=-0.3 m

BC H=0
DR=2.25

N° SOSTEGNO

42

SOSTEGNO

LSU14B

LUNGHEZZA
MENSOLE
TIRANTI

Mensola=4.20
Tirante=2.9

CAT./PROG.
SOSPENSIONI

773/790

SCALA 1:100

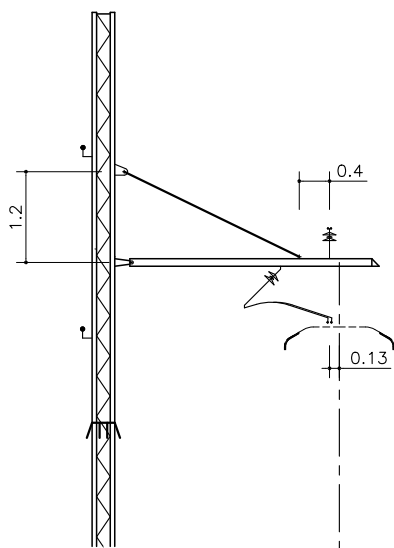

B0a

HFC=5.2 m d=-0.3 m

BC H=0
DR=2.25

N° SOSTEGNO

43

SOSTEGNO

LSU14B

LUNGHEZZA
MENSOLE
TIRANTI

Mensola=3.20
Tirante=2.6

CAT./PROG.
SOSPENSIONI

773/788

SCALA 1:100

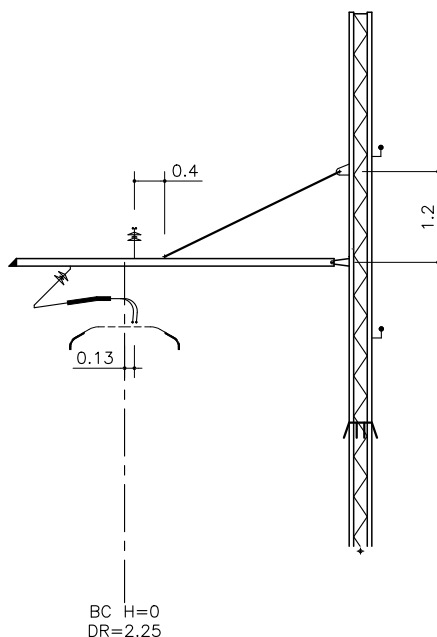

P4

HFC=5.2 m d=-0.3 m

N° SOSTEGNO

44

SOSTEGNO

LSU14B

LUNGHEZZA
MENSOLE
TIRANTI

Mensola=4.20
Tirante=2.6

CAT./PROG.
SOSPENSIONI

773/794

SCALA 1:100

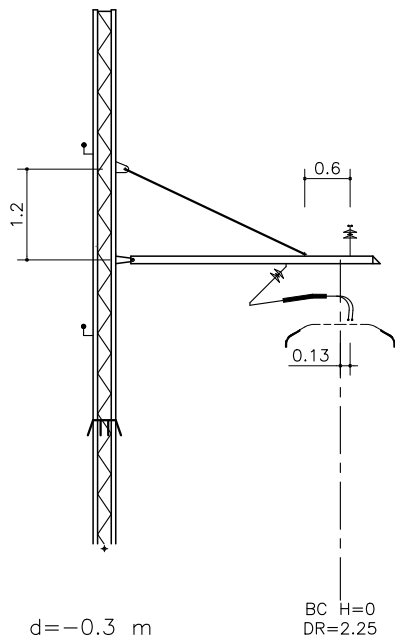

B0a

HFC=5.2 m d=-0.3 m

BC H=0
DR=2.25

N° SOSTEGNO

45

SOSTEGNO

LSU14B

LUNGHEZZA
MENSOLE
TIRANTI

Mensola=3.20
Tirante=2.6

CAT./PROG.
SOSPENSIONI

773/793

SCALA 1:100

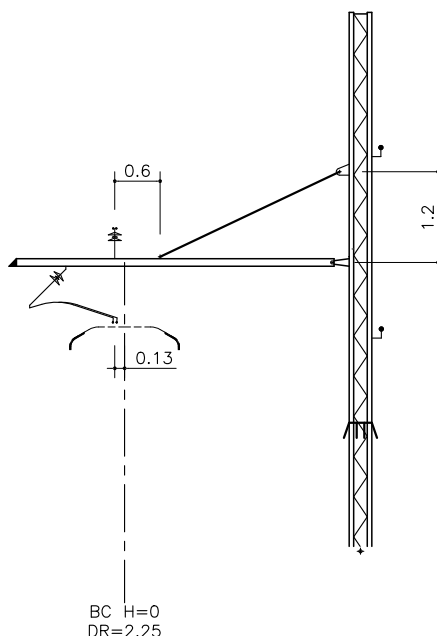

P4

HFC=5.2 m d=-0.3 m

BC H=0
DR=2.25

N° SOSTEGNO

46

SOSTEGNO

LSU14B

LUNGHEZZA
MENSOLE
TIRANTI

Mensola=4.20
Tirante=2.6

CAT./PROG.
SOSPENSIONI

773/669

SCALA 1:100

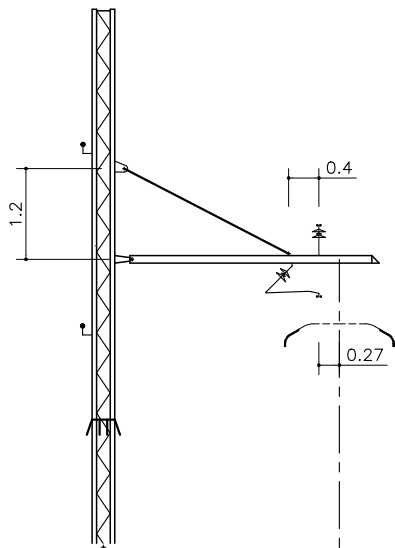

B0a

HFC=5.2 m d=-0.3 m

BC H=0
DR=2.25

N° SOSTEGNO

47

SOSTEGNO

LSU14B

LUNGHEZZA
MENSOLE
TIRANTI

Mensola=3.20
Tirante=2.4

CAT./PROG.
SOSPENSIONI

773/789

SCALA 1:100

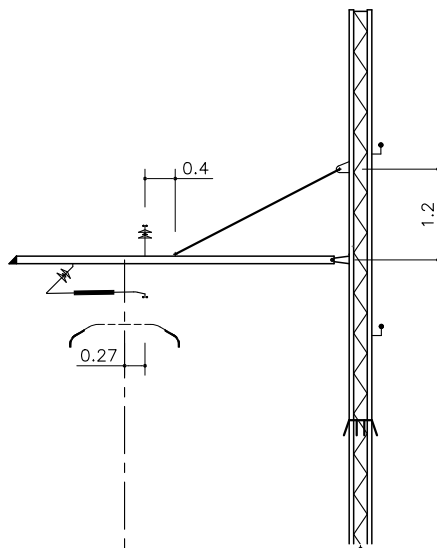

P3

HFC=5.2 m d=-0.3 m

BC H=0
DR=2.25

N° SOSTEGNO

48

SOSTEGNO

LSU14B

LUNGHEZZA
MENSOLE
TIRANTI

Mensola=4.20
Tirante=2.4

CAT./PROG.
SOSPENSIONI

773/792

SCALA 1:100

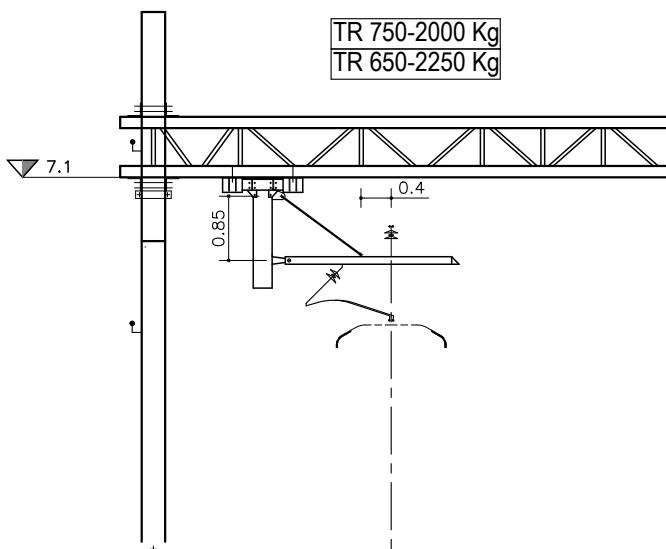

PT2

HFC=5.2 m d=-0.3 m

BC H=0
DR=2.27

N° SOSTEGNO

49

SOSTEGNO

POT 2B

LUNGHEZZA
MENSOLE
TIRANTI

Mensola=2.20
Tirante=1.3

CAT./PROG.
SOSPENSIONI

773/903

SCALA 1:100

H PILONE=9.586 m

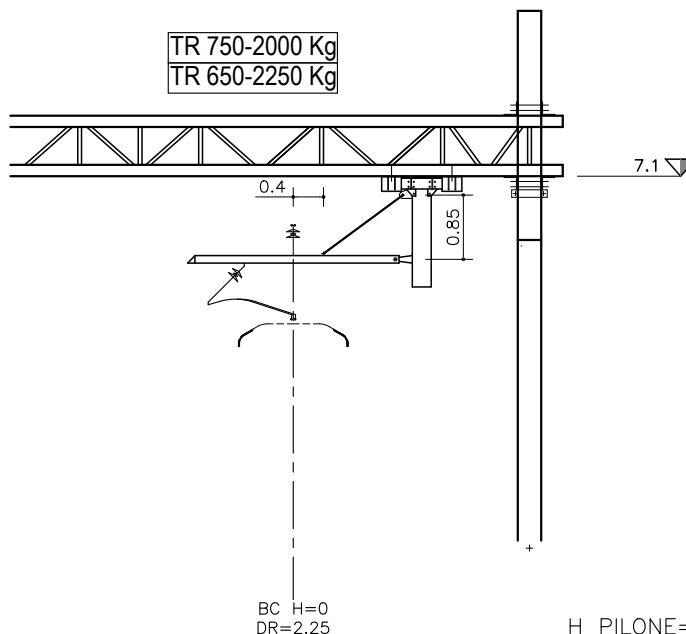

PT2

HFC=5.2 m d=-0.3 m

N° SOSTEGNO	50
SOSTEGNO	POT 2B
LUNGHEZZA MENSOLE TIRANTI	Mensola=2.70 Tirante=1.3
CAT./PROG. SOSPENSIONI	773/664
SCALA	1:100

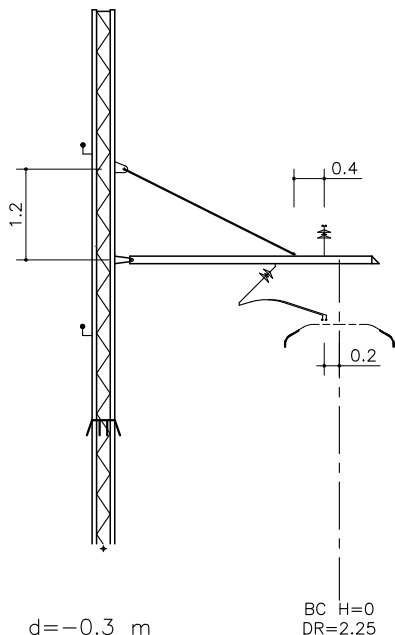

B0a

HFC=5.2 m d=-0.3 m

N° SOSTEGNO	51
SOSTEGNO	LSU14B
LUNGHEZZA MENSOLE TIRANTI	Mensola=3.20 Tirante=2.5
CAT./PROG. SOSPENSIONI	773/788
SCALA	1:100

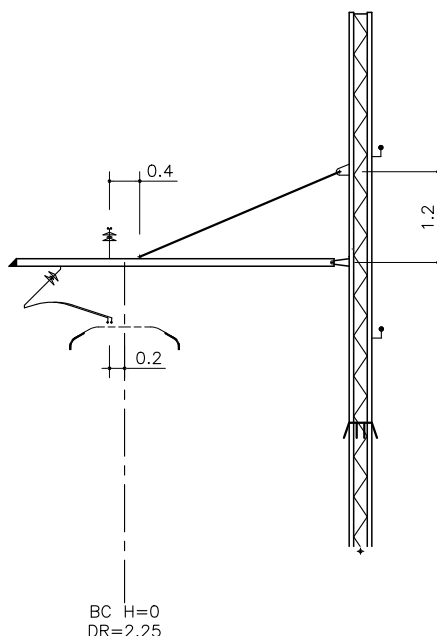

P4

HFC=5.2 m d=-0.3 m

N° SOSTEGNO	52
SOSTEGNO	LSU14B
LUNGHEZZA MENSOLE TIRANTI	Mensola=4.20 Tirante=2.9
CAT./PROG. SOSPENSIONI	773/669
SCALA	1:100

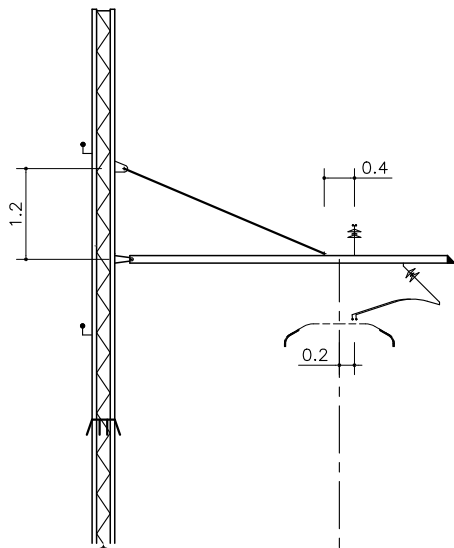

B0a

HFC=5.2 m d=-0.3 m

BC H=0
DR=2.25

N° SOSTEGNO

53

SOSTEGNO

LSU14B

LUNGHEZZA
MENSOLE
TIRANTI

Mensola=4.20
Tirante=2.9

CAT./PROG.
SOSPENSIONI

773/669

SCALA 1:100

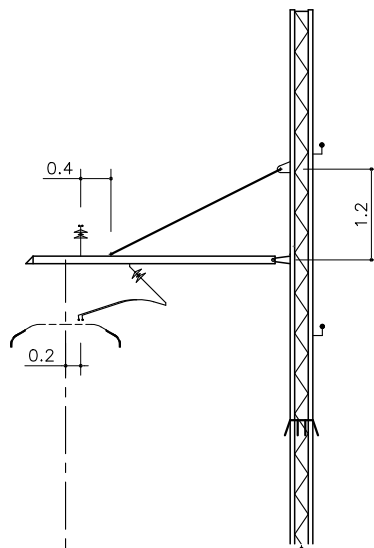

P4

HFC=5.2 m d=-0.3 m

BC H=0
DR=2.25

N° SOSTEGNO

54

SOSTEGNO

LSU14B

LUNGHEZZA
MENSOLE
TIRANTI

Mensola=3.20
Tirante=2.5

CAT./PROG.
SOSPENSIONI

773/788

SCALA 1:100

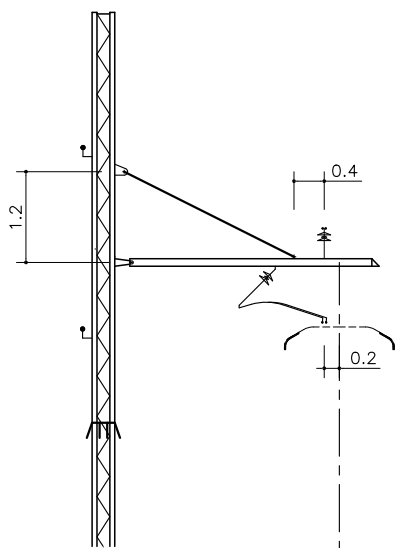

B1

HFC=5.2 m d=-0.3 m

BC H=0
DR=2.25

N° SOSTEGNO

55

SOSTEGNO

LSU16B

LUNGHEZZA
MENSOLE
TIRANTI

Mensola=3.20
Tirante=2.5

CAT./PROG.
SOSPENSIONI

773/788

SCALA 1:100

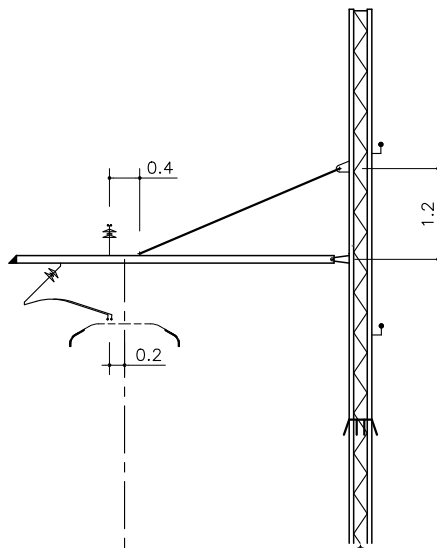

BC H=0
DR=2.25

P4

HFC=5.2 m d=-0.3 m

N° SOSTEGNO

56

SOSTEGNO

LSU14B

LUNGHEZZA
MENSOLE
TIRANTI

Mensola=4.20
Tirante=2.9

CAT./PROG.
SOSPENSIONI

773/669

SCALA 1:100

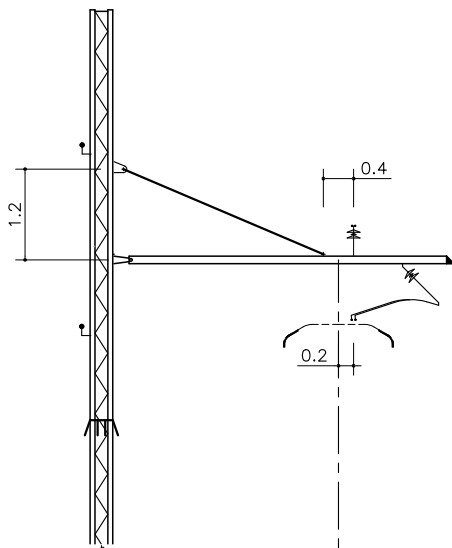

BC H=0
DR=2.25

B1

HFC=5.2 m d=-0.3 m

N° SOSTEGNO

57

SOSTEGNO

LSU16B

LUNGHEZZA
MENSOLE
TIRANTI

Mensola=4.20
Tirante=2.9

CAT./PROG.
SOSPENSIONI

773/669

SCALA 1:100

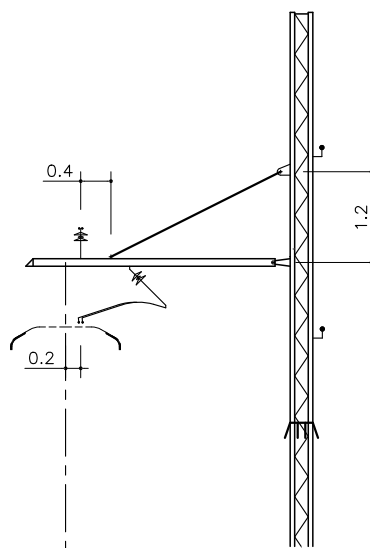

BC H=0
DR=2.25

B0a

HFC=5.2 m d=-0.3 m

N° SOSTEGNO

58

SOSTEGNO

LSU14B

LUNGHEZZA
MENSOLE
TIRANTI

Mensola=3.20
Tirante=2.5

CAT./PROG.
SOSPENSIONI

773/788

SCALA 1:100

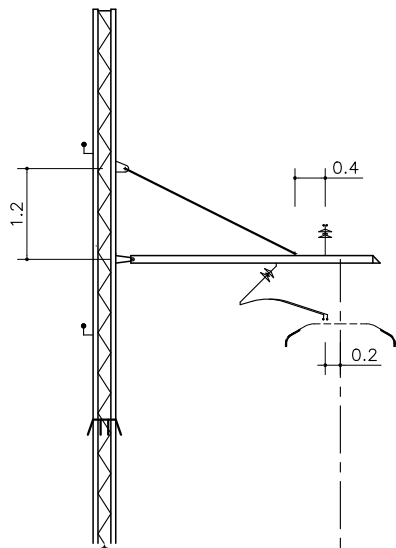

B1

HFC=5.2 m d=-0.3 m

BC H=0
DR=2.25

N° SOSTEGNO

59

SOSTEGNO

LSU16B

LUNGHEZZA
MENSOLE
TIRANTI

Mensola=3.20

Tirante=2.5

CAT./PROG.
SOSPENSIONI

773/788

SCALA 1:100

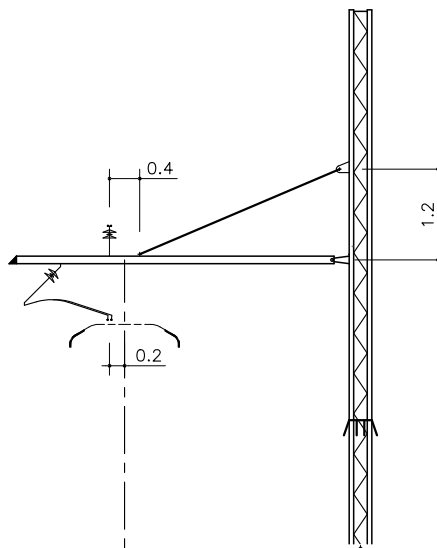

B0a

HFC=5.2 m d=-0.3 m

BC H=0
DR=2.25

N° SOSTEGNO

60

SOSTEGNO

LSU14B

LUNGHEZZA
MENSOLE
TIRANTI

Mensola=4.20

Tirante=2.9

CAT./PROG.
SOSPENSIONI

773/669

SCALA 1:100

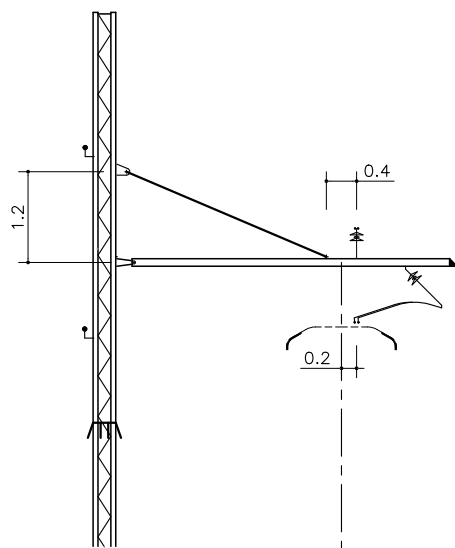

B1

HFC=5.2 m d=-0.3 m

BC H=0
DR=2.25

N° SOSTEGNO

61

SOSTEGNO

LSU16B

LUNGHEZZA
MENSOLE
TIRANTI

Mensola=4.20

Tirante=2.9

CAT./PROG.
SOSPENSIONI

773/669

SCALA 1:100

B0a

HFC=5.2 m d=-0.3 m

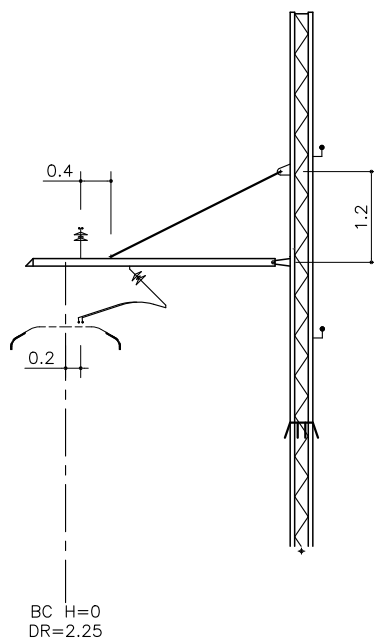

N° SOSTEGNO

62

SOSTEGNO

LSU14B

LUNGHEZZA
MENSOLE
TIRANTI

Mensola=3.20
Tirante=2.5

CAT./PROG.
SOSPENSIONI

773/788

SCALA 1:100

B4

HFC=5.2 m d=-0.3 m

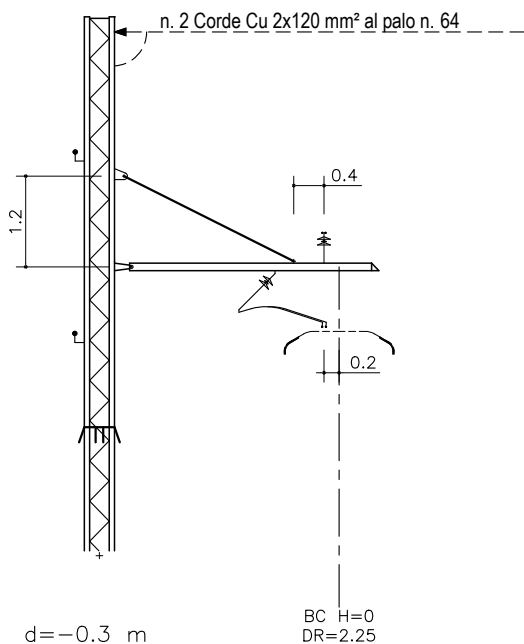

N° SOSTEGNO

63

SOSTEGNO

LSU18B

LUNGHEZZA
MENSOLE
TIRANTI

Mensola=3.20
Tirante=2.5

CAT./PROG.
SOSPENSIONI

SCALA

B3a

HFC=5.2 m d=-0.3 m

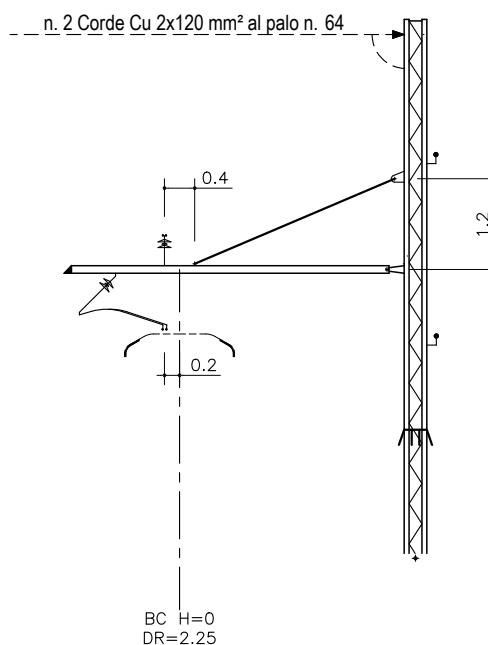

N° SOSTEGNO

64

SOSTEGNO

LSU16B

LUNGHEZZA
MENSOLE
TIRANTI

Mensola=4.20
Tirante=2.9

CAT./PROG.
SOSPENSIONI

773/669

SCALA 1:100

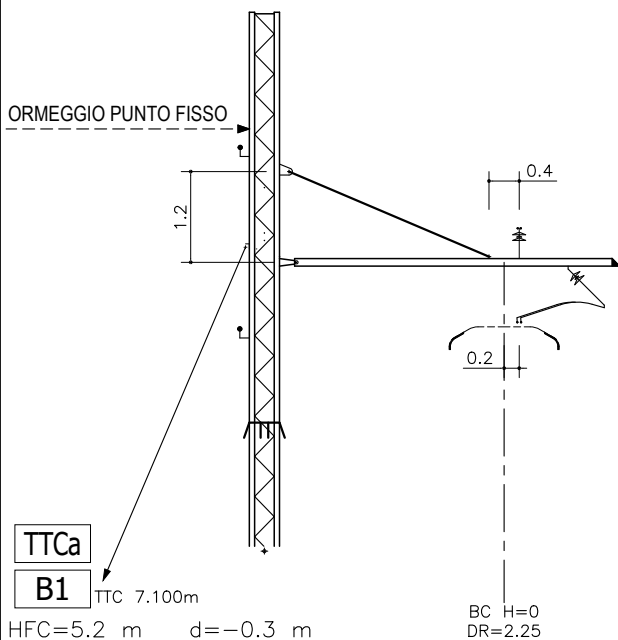

N° SOSTEGNO

65

SOSTEGNO

LSU18B

LUNGHEZZA
MENSOLE
TIRANTI

Mensola=4.20
Tirante=2.9

CAT./PROG.
SOSPENSIONI

773/669

SCALA 1:100

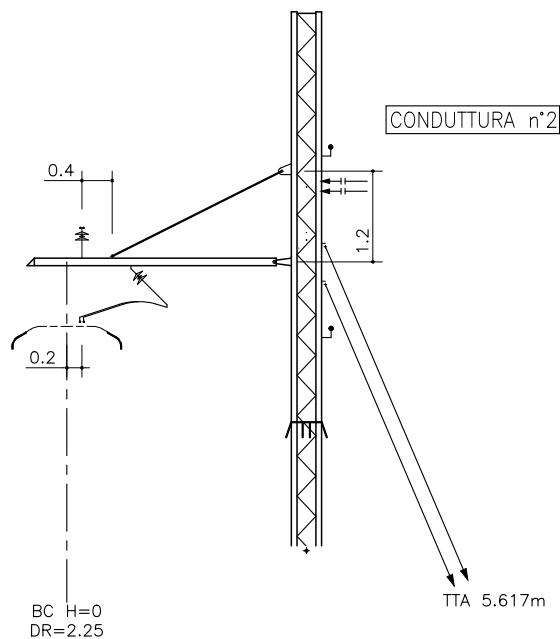

N° SOSTEGNO

66

SOSTEGNO

LSU20B

LUNGHEZZA
MENSOLE
TIRANTI

Mensola=3.20
Tirante=2.5

CAT./PROG.
SOSPENSIONI

773/788

SCALA 1:100

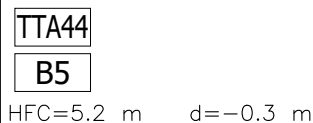

N° SOSTEGNO

67

SOSTEGNO

LSU16B

LUNGHEZZA
MENSOLE
TIRANTI

Mensola=3.20
Tirante=2.7

CAT./PROG.
SOSPENSIONI

773/788

SCALA 1:100

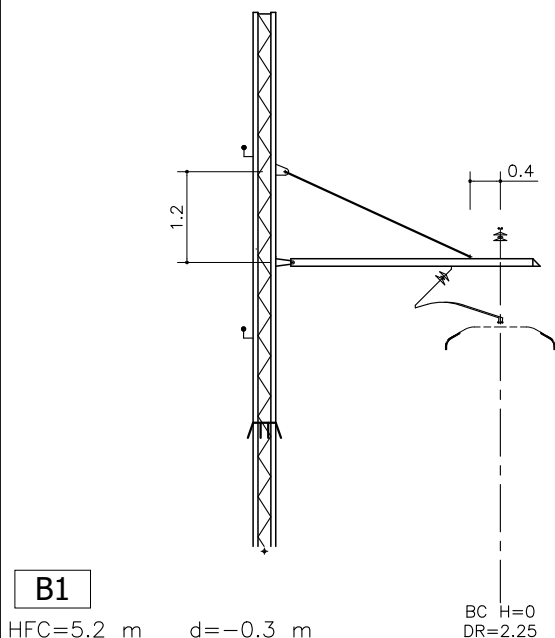

Vista in pianta

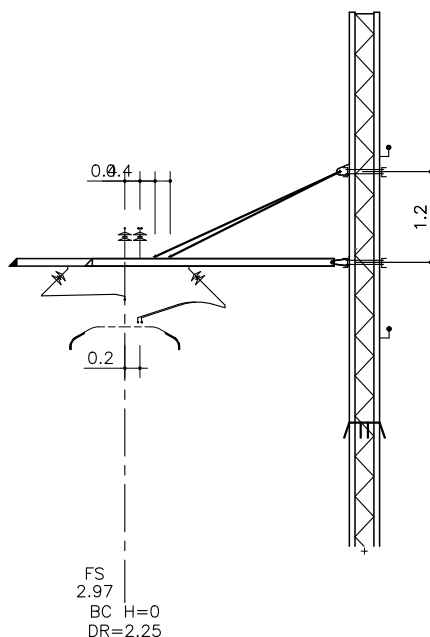
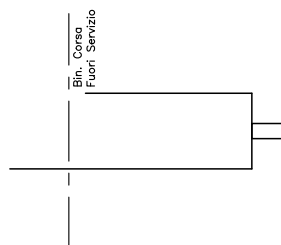

P6

HFC=5.2 m d=-0.3 m

N° SOSTEGNO

68

SOSTEGNO

LSU20B

LUNGHEZZA
MENSOLE
TIRANTI

Mensola=3.20

Tirante=2.4

Mensola=4.20

Tirante=2.6

CAT./PROG.
SOSPENSIONI

773/937

773/788

SCALA 1:100

ORMEGGIO PUNTO FISSO

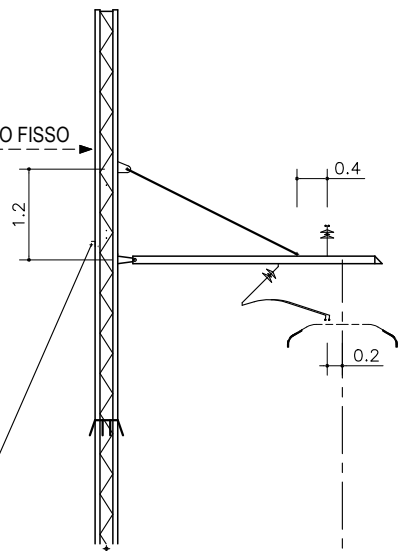

TTCa

B1

TTC 7.100m

HFC=5.2 m d=-0.3 m

BC H=0
DR=2.25

N° SOSTEGNO

69

SOSTEGNO

LSU16B

LUNGHEZZA
MENSOLE
TIRANTI

Mensola=3.20

Tirante=2.5

CAT./PROG.
SOSPENSIONI

773/788

SCALA 1:100

Vista in pianta

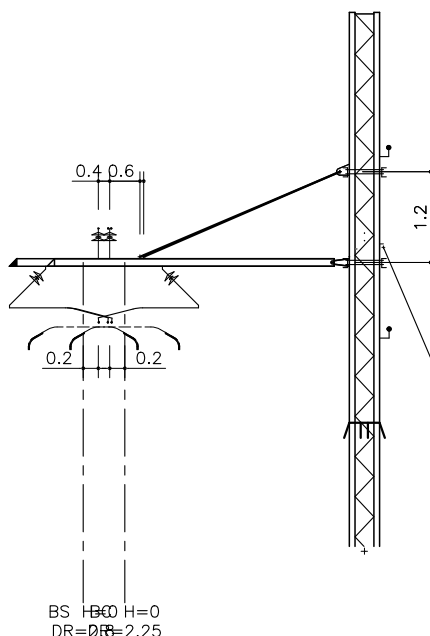
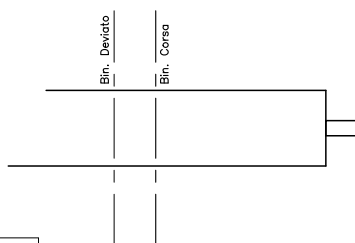

TTCa

P6

HFC=5.2 m d=-0.3 m

BS H=0
BC H=0
DR=2.25

TTC 7.100m

N° SOSTEGNO

70

SOSTEGNO

LSU20B

LUNGHEZZA
MENSOLE
TIRANTI

Mensola=4.20

Tirante=2.9

Mensola=3.70

Tirante=2.8

CAT./PROG.
SOSPENSIONI

773/797

773/991

SCALA 1:100

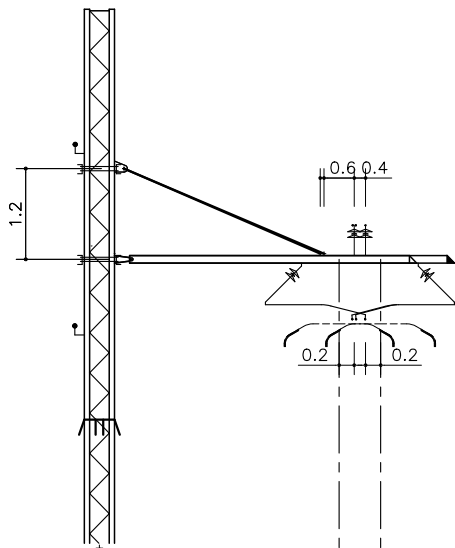

Vista in pianta



P6

HFC=5.2 m d=-0.3 m

BC H=0
DR=2.25

N° SOSTEGNO

71

SOSTEGNO

LSU18B

LUNGHEZZA
MENSOLE
TIRANTI

Mensola=4.20

Tirante=2.9

Mensola=3.70

Tirante=2.8

CAT./PROG.
SOSPENSIONI

773/797

773/991

SCALA 1:100

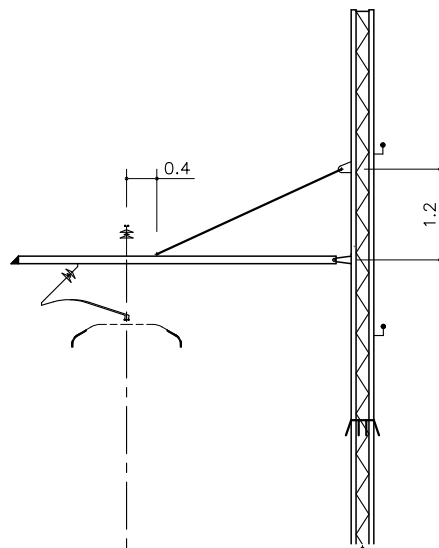

B4

HFC=5.2 m d=-0.3 m

BC H=0
DR=2.25

N° SOSTEGNO

72

SOSTEGNO

LSU16B

LUNGHEZZA
MENSOLE
TIRANTI

Mensola=4.20

Tirante=2.7

CAT./PROG.
SOSPENSIONI

773/669

SCALA 1:100

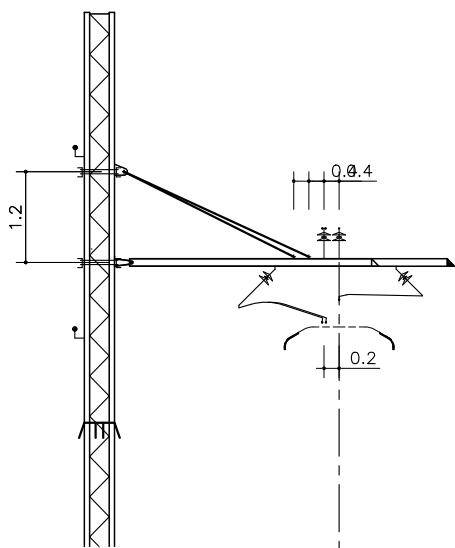

Vista in pianta



P6

HFC=5.2 m d=-0.3 m

FS
2.97
BC H=0
DR=2.25

N° SOSTEGNO

73

SOSTEGNO

LSU18B

LUNGHEZZA
MENSOLE
TIRANTI

Mensola=3.20

Tirante=2.4

Mensola=4.20

Tirante=2.6

CAT./PROG.
SOSPENSIONI

773/937

773/788

SCALA 1:100

TTA44

B4

HFC=5.2 m d=-0.3 m

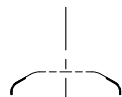

BC H=0
DR=2.25

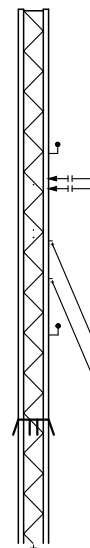

CONDUTTURA n°4p-4p

TTA 5.617m

N° SOSTEGNO

74/1

SOSTEGNO

LSU18B

LUNGHEZZA
MENSOLE
TIRANTI

CAT./PROG.
SOSPENSIONI

SCALA 1:100

B0a

HFC=5.2 m d=-0.3 m

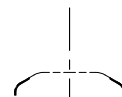

BC H=0
DR=2.25

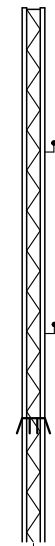

N° SOSTEGNO

74

SOSTEGNO

LSU14B

LUNGHEZZA
MENSOLE
TIRANTI

CAT./PROG.
SOSPENSIONI

SCALA 1:100

TR 750-750 Kg



BC H=0
DR=2.25

TTBa

B4

TTB 6.077m

HFC=5.2 m d=-0.3 m

N° SOSTEGNO

75/1

SOSTEGNO

LSU18B

LUNGHEZZA
MENSOLE
TIRANTI

CAT./PROG.
SOSPENSIONI

SCALA 1:100

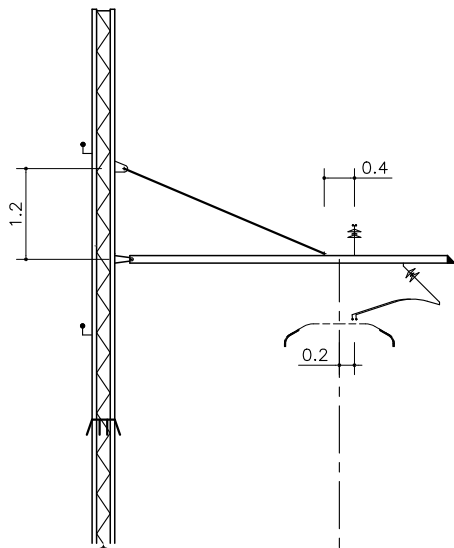

B0a

HFC=5.2 m d=-0.3 m

BC H=0
DR=2.25

N° SOSTEGNO

75

SOSTEGNO

LSU14B

LUNGHEZZA
MENSOLE
TIRANTI

Mensola=4.20
Tirante=2.9

CAT./PROG.
SOSPENSIONI

773/669

SCALA 1:100

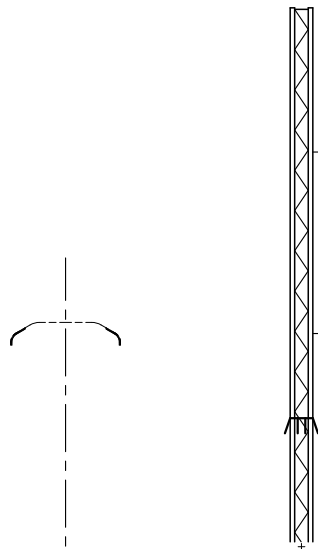

B0a

HFC=5.2 m d=-0.3 m

BC H=0
DR=2.25

N° SOSTEGNO

76

SOSTEGNO

LSU14B

LUNGHEZZA
MENSOLE
TIRANTI

CAT./PROG.
SOSPENSIONI

SCALA 1:100

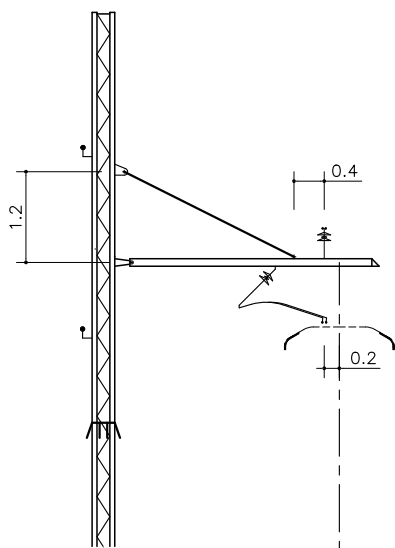

B0a

HFC=5.2 m d=-0.3 m

BC H=0
DR=2.25

N° SOSTEGNO

77

SOSTEGNO

LSU16B

LUNGHEZZA
MENSOLE
TIRANTI

Mensola=3.20
Tirante=2.5

CAT./PROG.
SOSPENSIONI

773/788

SCALA 1:100

B0a

HFC=5.2 m d=-0.3 m

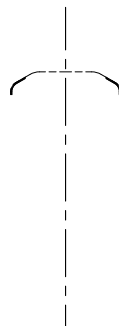

BC H=0
DR=2.25

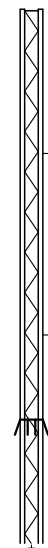

N° SOSTEGNO

78

SOSTEGNO

LSU14B

LUNGHEZZA
MENSOLE
TIRANTI

CAT./PROG.
SOSPENSIONI

SCALA 1:100

B3a

HFC=5.2 m d=-0.3 m

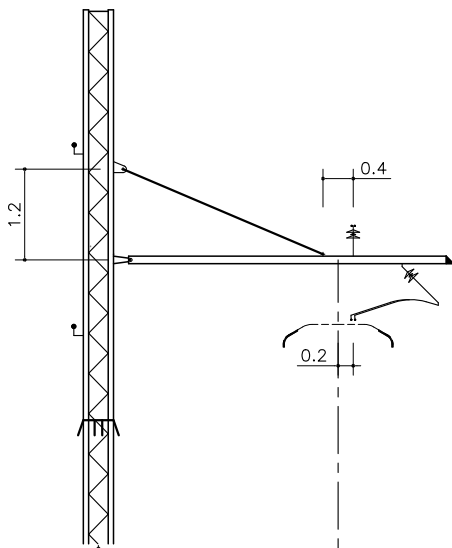

BC H=0
DR=2.25

N° SOSTEGNO

79

SOSTEGNO

LSU18B

LUNGHEZZA
MENSOLE
TIRANTI

Mensola=4.20

Tirante=2.9

CAT./PROG.
SOSPENSIONI

773/669

SCALA 1:100

B0a

HFC=5.2 m d=-0.3 m

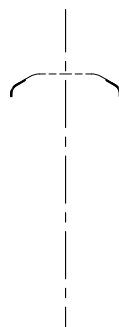

BC H=0
DR=2.25

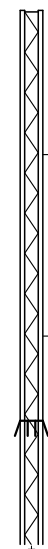

N° SOSTEGNO

80

SOSTEGNO

LSU14B

LUNGHEZZA
MENSOLE
TIRANTI

CAT./PROG.
SOSPENSIONI

SCALA 1:100

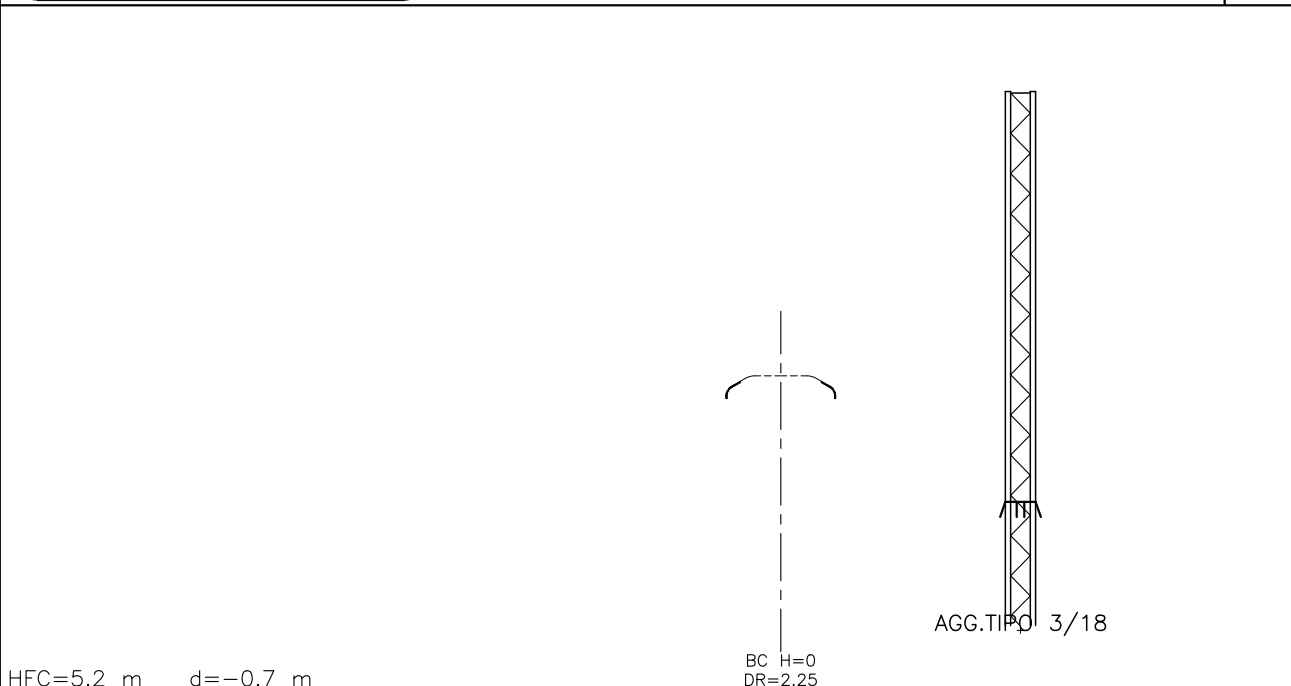

N° SOSTEGNO	82
SOSTEGNO	LSU18SB
LUNGHEZZA MENSOLE TIRANTI	
CAT./PROG. SOSPENSIONI	
SCALA	1:100

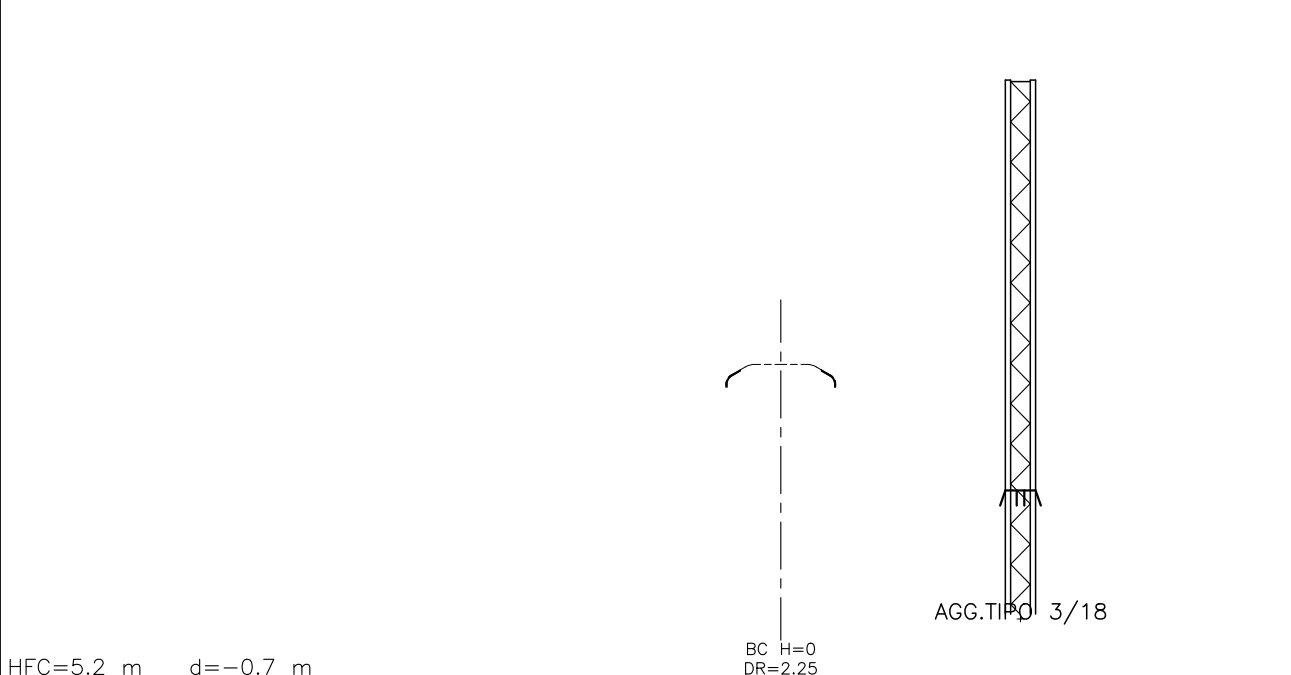

N° SOSTEGNO	84
SOSTEGNO	LSU18SB
LUNGHEZZA MENSOLE TIRANTI	
CAT./PROG. SOSPENSIONI	
SCALA	1:100

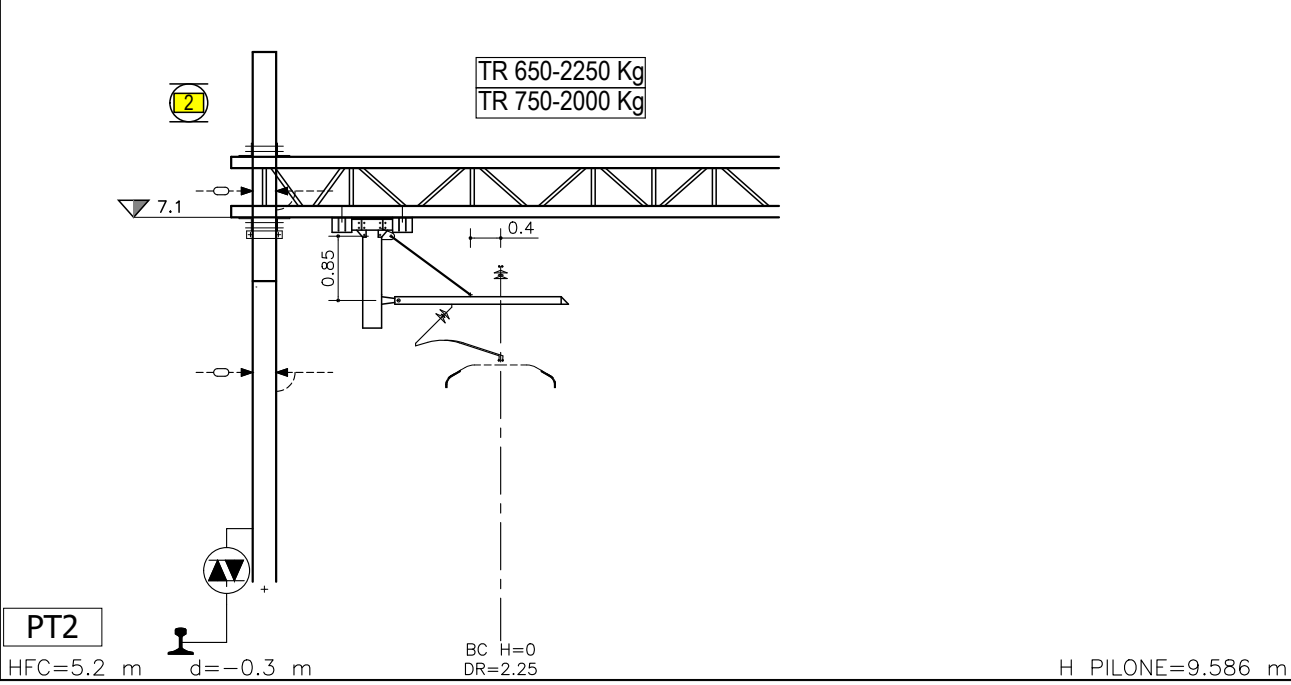

N° SOSTEGNO	85
SOSTEGNO	POT 2B
LUNGHEZZA MENSOLE TIRANTI	
Mensola=2.20 Tirante=1.3	
CAT./PROG. SOSPENSIONI	773/903
SCALA	1:100

PT2
HFC=5.2 m d=-0.3 m

BC H=0
DR=2.25

H PILONE=9.586 m

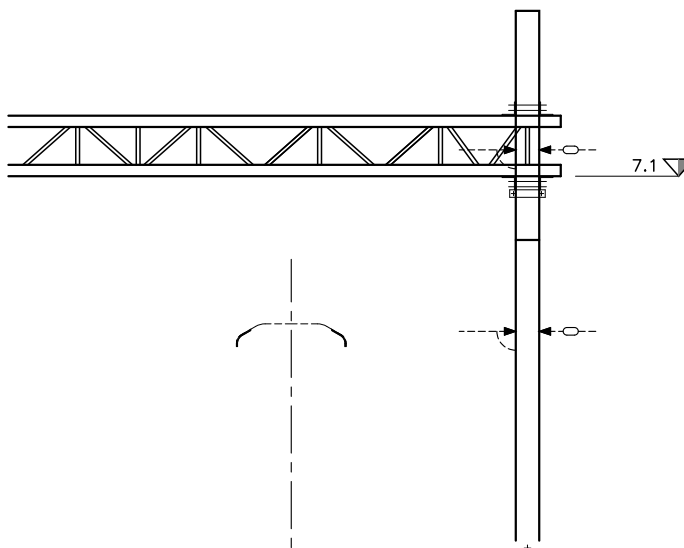

BC H=0
DR=2.25

H PILONE=9.586 m

PT2

HFC=5.2 m d=-0.3 m

N° SOSTEGNO

86

SOSTEGNO

POT 2B

LUNGHEZZA
MENSOLE
TIRANTI

CAT./PROG.
SOSPENSIONI

SCALA 1:100

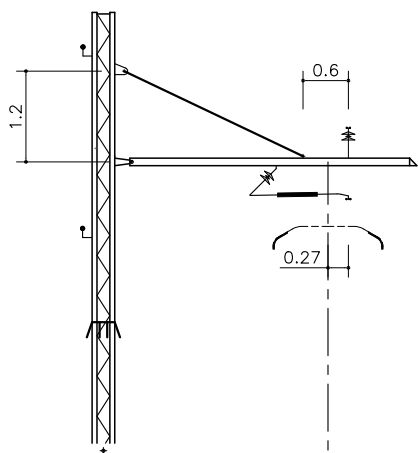

BC H=0
DR=2.1

B1

HFC=5.2 m d=-0.3 m

N° SOSTEGNO

87

SOSTEGNO

LSU16A

LUNGHEZZA
MENSOLE
TIRANTI

Mensola=3.70

Tirante=2.6

CAT./PROG.
SOSPENSIONI

773/916

SCALA 1:100

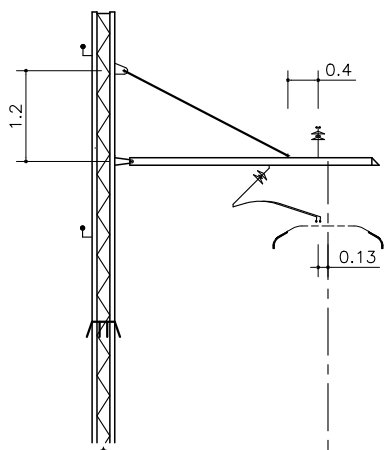

BC H=0
DR=2.1

B1

HFC=5.2 m d=-0.3 m

N° SOSTEGNO

89

SOSTEGNO

LSU16A

LUNGHEZZA
MENSOLE
TIRANTI

Mensola=3.20

Tirante=2.4

CAT./PROG.
SOSPENSIONI

773/788

SCALA 1:100

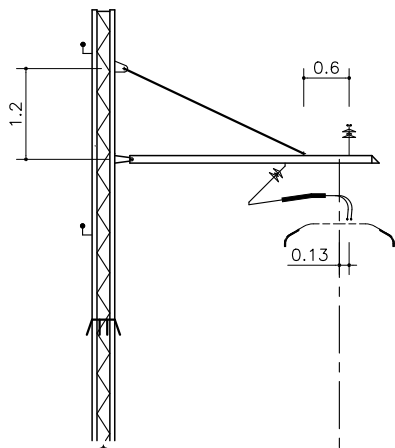

B1

HFC=5.2 m d=-0.3 m

BC H=0
DR=2.25

N° SOSTEGNO

91

SOSTEGNO

LSU16A

LUNGHEZZA
MENSOLE
TIRANTI

Mensola=3.20
Tirante=2.6

CAT./PROG.
SOSPENSIONI

773/793

SCALA 1:100

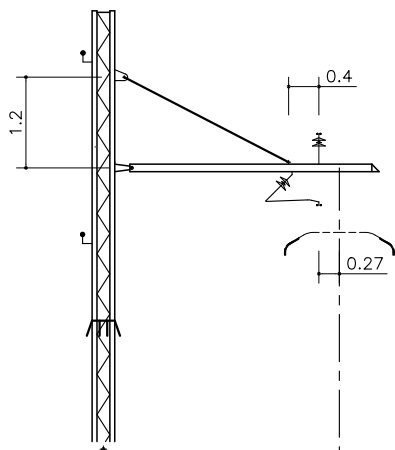

B1

HFC=5.2 m d=-0.2 m

BC H=0
DR=2.25

N° SOSTEGNO

93P

SOSTEGNO

LSU16A

LUNGHEZZA
MENSOLE
TIRANTI

Mensola=3.20
Tirante=2.4

CAT./PROG.
SOSPENSIONI

773/789

SCALA 1:100

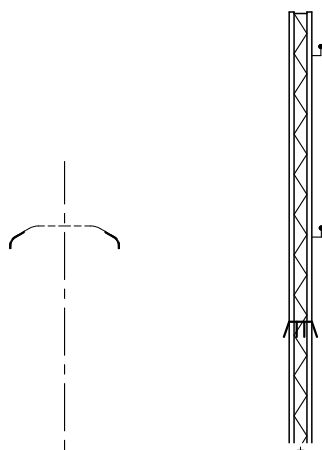

B1

HFC=5.2 m d=-0.3 m

BC H=0
DR=2.25

N° SOSTEGNO

88

SOSTEGNO

LSU16A

LUNGHEZZA
MENSOLE
TIRANTI

CAT./PROG.
SOSPENSIONI

SCALA 1:100

B1

HFC=5.2 m d=-0.3 m

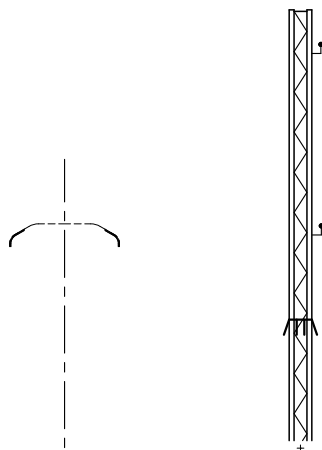

BC H=0
DR=2.25

N° SOSTEGNO

90

SOSTEGNO

LSU16A

LUNGHEZZA
MENSOLE
TIRANTI

CAT./PROG.
SOSPENSIONI

SCALA 1:100

B0a

HFC=5.2 m d=-0.3 m

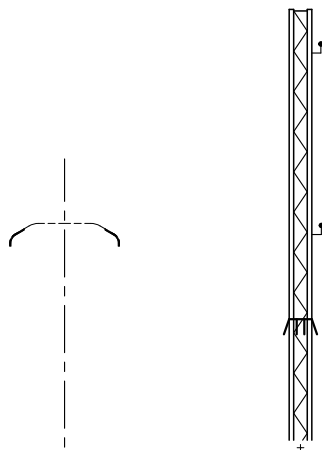

BC H=0
DR=2.25

N° SOSTEGNO

92

SOSTEGNO

LSU14A

LUNGHEZZA
MENSOLE
TIRANTI

CAT./PROG.
SOSPENSIONI

SCALA 1:100

B0a

HFC=5.2 m d=-0.3 m

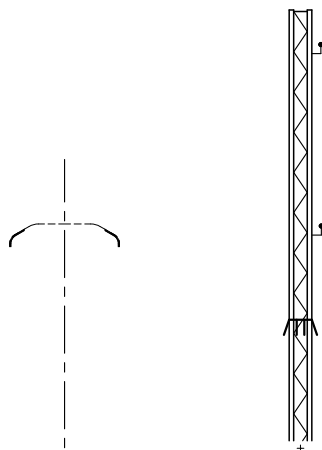

BC H=0
DR=2.25

N° SOSTEGNO

94

SOSTEGNO

LSU14A

LUNGHEZZA
MENSOLE
TIRANTI

CAT./PROG.
SOSPENSIONI

SCALA 1:100

TABELLA MENSOLE
Schema di montaggio

Stazione di

PM RIPALTA

Pagina

37

LUCE TRAVE=12.00

TIPO TRAVE=T-3

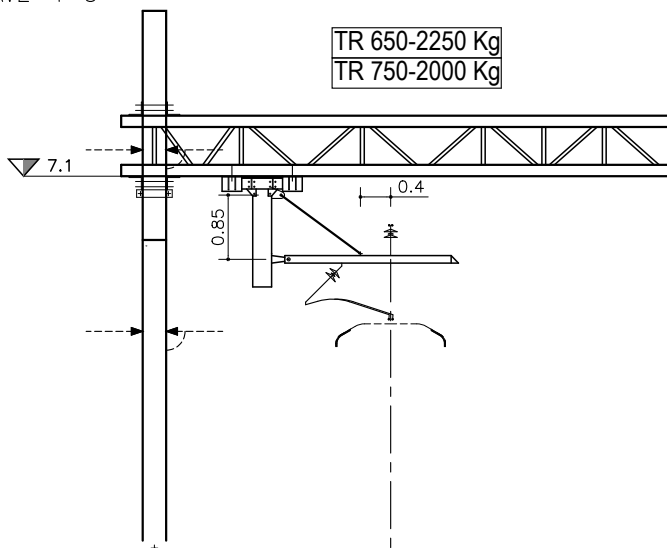

HFC=5.2 m d=-0.3 m

BC H=0
DR=2.25

H PILONE=9.586 m

LUCE TRAVE=12.00

TIPO TRAVE=T-2

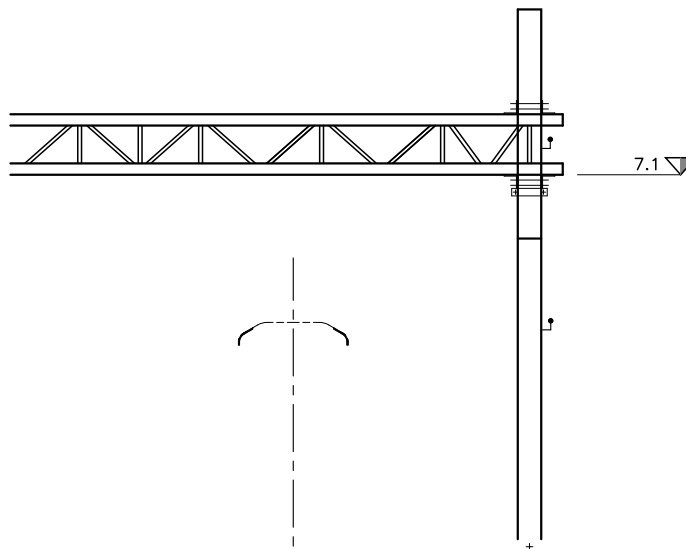

HFC=5.2 m d=-0.3 m

BC H=0
DR=2.25

H PILONE=9.586 m

N° SOSTEGNO

95

SOSTEGNO

PT-12.00

LUNGHEZZA
MENSOLE
TIRANTI

Mensola=2.20
Tirante=1.3

CAT./PROG.
SOSPENSIONI

773/903

SCALA 1:100

N° SOSTEGNO

96

SOSTEGNO

PT-12.00

LUNGHEZZA
MENSOLE
TIRANTI

CAT./PROG.
SOSPENSIONI

SCALA 1:100

N° SOSTEGNO

SOSTEGNO

LUNGHEZZA
MENSOLE
TIRANTI

CAT./PROG.
SOSPENSIONI

SCALA