

Developer Package

SG 6.0-170



Application of the Developer Package

The Developer Package serves the purpose of informing customers about the latest planned product development from Siemens Gamesa Renewable Energy A/S and its affiliates in the Siemens Gamesa group including Siemens Gamesa Renewable Energy S.A. and its subsidiaries (hereinafter "SGRE"). By sharing information about coming developments, SGRE can ensure that customers are provided with necessary information to make decisions.

Furthermore, the Developer Package can assist in guiding prospective customers with the indicated technical footprint of the SG 6.0-170 in cases where financial institutes, governing bodies, or permitting entities require product specific information in their decision processes.

All technical data contained in the Developer Package is subject to change owing to ongoing technical developments of the wind turbine. Consequently, SGRE and its affiliates reserve the right to change the below specifications without prior notice. Information contained within the Developer Package may not be treated separately or out of the context of the Developer Package.

Disclaimer of liability and conditions of use

To the extent permitted by law, neither Siemens Gamesa Renewable Energy A/S nor any of its affiliates in the Siemens Gamesa group including Siemens Gamesa Renewable Energy S.A. and its subsidiaries (hereinafter "SGRE") gives any warranty of any type, either express or implied, with respect to the use of this document or parts thereof other than the use of the document for its indented purpose. In no event will SGRE be liable for damages, including any general, special, incidental or consequential damages, arising out of the use of the document, the inability to use the document, the use of data embodied in, or obtained from, the document or the use of any documentation or other material accompanying the document except where the documents or other material accompanying the documents becomes part of an agreement between you and SGRE in which case the liability of SGRE will be regulated by the said agreement. SGRE reviews this document at regular intervals, and includes appropriate amendments in subsequent issues. The intellectual property rights of this document are and remain the property of SGRE. SGRE reserves the right to update this documentation from time to time, or to change it without prior notice.

The information contained in the Developer Package may not be used as legally binding documentation and cannot be used in contracts between SGRE and any other parties.

Developer Package

SG 6.0-170

Table of content

Technical Description	5
Technical Specifications.....	7
Nacelle Arrangement.....	8
Nacelle Dimensions.....	9
Preliminary Elevation Drawing	10
Blade Sales Drawing	11
Tower dimensions	12
Foundation Dimensions and loads	12
Electrical Specifications	17
Simplified Single Line Diagram	18
Transformer Specifications ECO 30 kV	18
Switchgear Specifications	19
Technical Data for Switchgear.....	21
Grid Performance Specification, 50 Hz.....	22
Grid Performance Specification, 60 Hz.....	25
Fault Ride Through (FRT) Capability.....	25
Reactive Power Capability, 50 and 60 Hz.....	28
SCADA, System Description	31
Codes and Standards.....	34
Other Performance Features	37
Ice Detection System	38

Introduction

The SG 6.0-170 is a new wind turbine of the next generation Siemens Gamesa Onshore Geared product platform called Siemens Gamesa 5.X, which builds on the Siemens Gamesa design and operational experience in the wind energy market.

With a new 83.5 m blade and an extensive tower portfolio including hub heights ranging from 100 m to 165 m, the SG 6.0-170 aims at becoming a new benchmark in the market for efficiency and profitability.

This Developer Package describes the turbine technical specifications and provides information for the main components and subsystems.

For further information, please contact your regional SGRE Sales Manager.

Technical Description

Rotor-Nacelle

The rotor is a three-bladed construction, mounted upwind of the tower. The power output is controlled by pitch and torque demand regulation. The rotor speed is variable and is designed to maximize the power output while maintaining loads and noise level.

The nacelle has been designed for safe access to all service points during scheduled service. In addition the nacelle has been designed for safe presence of service technicians in the nacelle during Service Test Runs with the wind turbine in full operation. This allows a high quality service of the wind turbine and provides optimum troubleshooting conditions.

Blades

Siemens Gamesa 5.X blades are made up of fiberglass infusion & carbon pultruded-molded components. The blade structure uses aerodynamic shells containing embedded spar-caps, bonded to two main epoxy-fiberglass-balsa/foam-core shear webs. The Siemens Gamesa 5.X blades use a blade design based on SGRE proprietary airfoils.

Rotor Hub

The rotor hub is cast in nodular cast iron and is fitted to the drive train low speed shaft with a flange connection. The hub is sufficiently large to provide room for service technicians during maintenance of blade roots and pitch bearings from inside the structure.

Drive train

The drive train is a 4-points suspension concept: main shaft with two main bearings and the gearbox with two torque arms assembled to the main frame.

The gearbox is in cantilever position; the gearbox planet carrier is assembled to the main shaft by means of a flange bolted joint and supports the gearbox.

Main Shaft

The low speed main shaft is forged and transfers the torque of the rotor to the gearbox and the bending moments to the bedframe via the main bearings and main bearing housings.

Main Bearings

The low speed shaft of the wind turbine is supported by two tapered roller bearings. The bearings are grease lubricated.

Gearbox

The gearbox is 3 stages high speed type (2 planetary + 1 parallel).

Generator

The generator is a doubly-fed asynchronous three phase generator with a wound rotor, connected to a frequency PWM converter. Generator stator and rotor are both made of stacked magnetic laminations and formed windings. Generator is cooled by air.

Mechanical Brake

The mechanical brake is fitted to the non-drive end of the gearbox.

Yaw System

A cast bed frame connects the drive train to the tower. The yaw bearing is an externally geared ring with a friction bearing. A series of electric planetary gear motors drives the yawing.

Nacelle Cover

The weather screen and housing around the machinery in the nacelle is made of fiberglass-reinforced laminated panels.

Tower

The wind turbine is as standard mounted on a tapered tubular steel tower. Other tower technologies are available for higher hub heights. The tower has internal ascent and direct access to the yaw system and nacelle. It is equipped with platforms and internal electric lighting.

Controller

The wind turbine controller is a microprocessor-based industrial controller. The controller is complete with switchgear and protection devices and is self-diagnosing.

Converter

Connected directly with the Rotor, the Frequency Converter is a back to back 4Q conversion system with 2 VSC in a common DC-link. The Frequency Converter allows generator operation at variable speed and voltage, while supplying power at constant frequency and voltage to the MV transformer.

SCADA

The wind turbine provides connection to the SGRE SCADA system. This system offers remote control and a variety of status views and useful reports from a standard internet web browser. The status views present information including electrical and mechanical data, operation and fault status, meteorological data and grid station data.

Turbine Condition Monitoring

In addition to the SGRE SCADA system, the wind turbine can be equipped with the unique SGRE condition monitoring setup. This system monitors the vibration level of the main components and compares the actual vibration spectra with a set of established reference spectra. Review of results, detailed analysis and reprogramming can all be carried out using a standard web browser.

Operation Systems

The wind turbine operates automatically. It is self-starting when the aerodynamic torque reaches a certain value. Below rated wind speed, the wind turbine controller fixes the pitch and torque references for operating in the optimum aerodynamic point (maximum production) taking into account the generator capability. Once rated wind speed is surpassed, the pitch position demand is adjusted to keep a stable power production equal to the nominal value.

If high wind derated mode is enabled, the power production is limited once the wind speed exceeds a threshold value defined by design, until cut-out wind speed is reached and the wind turbine stops producing power.

If the average wind speed exceeds the maximum operational limit, the wind turbine is shut down by pitching of the blades. When the average wind speed drops back below the restart average wind speed, the systems reset automatically.

Technical Specifications

Rotor

Type	3-bladed, horizontal axis
Position	Upwind
Diameter	170 m
Swept area	22,698 m ²
Power regulation	Pitch & torque regulation with variable speed
Rotor tilt	6 degrees

Blade

Type	Self-supporting
Blade length	83,5 m
Max chord	4.5 m
Aerodynamic profile.....	Siemens Gamesa proprietary airfoils
Material	G (Glassfiber) – CRP (Carbon Reinforced Plastic)
Surface gloss	Semi-gloss, < 30 / ISO2813
Surface color	Light grey, RAL 7035 or White, RAL 9018

Aerodynamic Brake

Type	Full span pitching
Activation	Active, hydraulic

Load-Supporting Parts

Hub	Nodular cast iron
Main shaft	Nodular cast iron
Nacelle bed frame	Nodular cast iron

Mechanical Brake

Type	Hydraulic disc brake
Position	Gearbox rear end

Nacelle Cover

Type	Totally enclosed
Surface gloss	Semi-gloss, <30 / ISO2813
Color	Light Grey, RAL 7035 or White, RAL 9018

Generator

Type.....	Asynchronous, DFIG
-----------	--------------------

Grid Terminals (LV)

Baseline nominal power ..	6.0 MW / 6.2 MW
Voltage.....	690 V
Frequency.....	50 Hz or 60 Hz

Yaw System

Type.....	Active
Yaw bearing	Externally geared
Yaw drive	Electric gear motors
Yaw brake	Active friction brake

Controller

Type	Siemens Integrated Control System (SICS)
SCADA system	SGRE SCADA System

Tower

Type	Tubular steel / Hybrid
------------	------------------------

Hub height	100 m to 165 m and site- specific
------------------	--------------------------------------

Corrosion protection	Painted
Surface gloss	Semi-gloss, <30 / ISO-2813
Color	Light grey, RAL 7035 or White, RAL 9018

Operational Data

Cut-in wind speed	3 m/s
Rated wind speed	11.0 m/s (steady wind without turbulence, as defined by IEC61400-1)
Cut-out wind speed	25 m/s
Restart wind speed.....	22 m/s

Weight

Modular approach.....	Different modules depending on restriction
-----------------------	---

Nacelle Arrangement

The design and layout of the nacelle are preliminary and may be subject to changes during the development of the product.

Item	Description	Item	Description
1	Canopy	8	Blade bearing
2	Generator	9	Converter
3	Blades	10	Cooling
4	Spinner/hub	11	Transformer
5	Gearbox	12	Stator cabinet.
6	Control panel	13	Front Control Cabinet
		14	Aviation structure

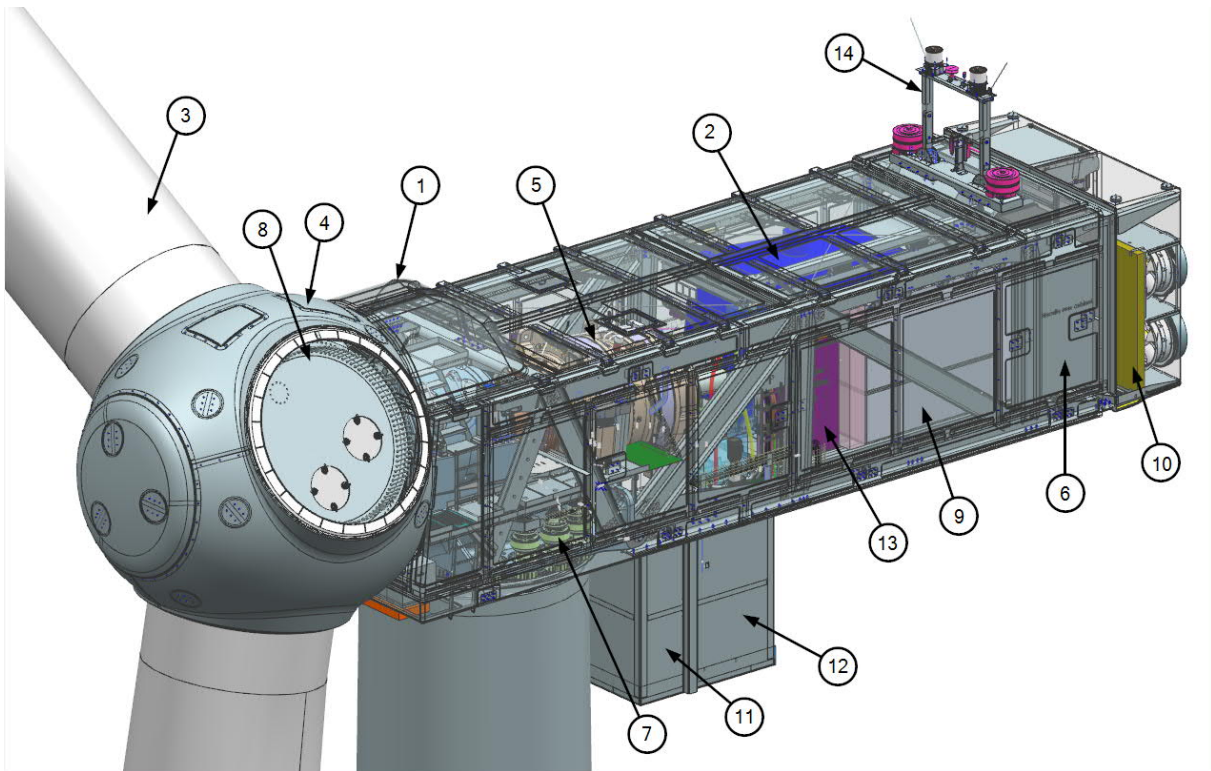

Nacelle Dimensions

The design and dimensions of the nacelle are preliminary and may be subject to changes during the development phases of the product.

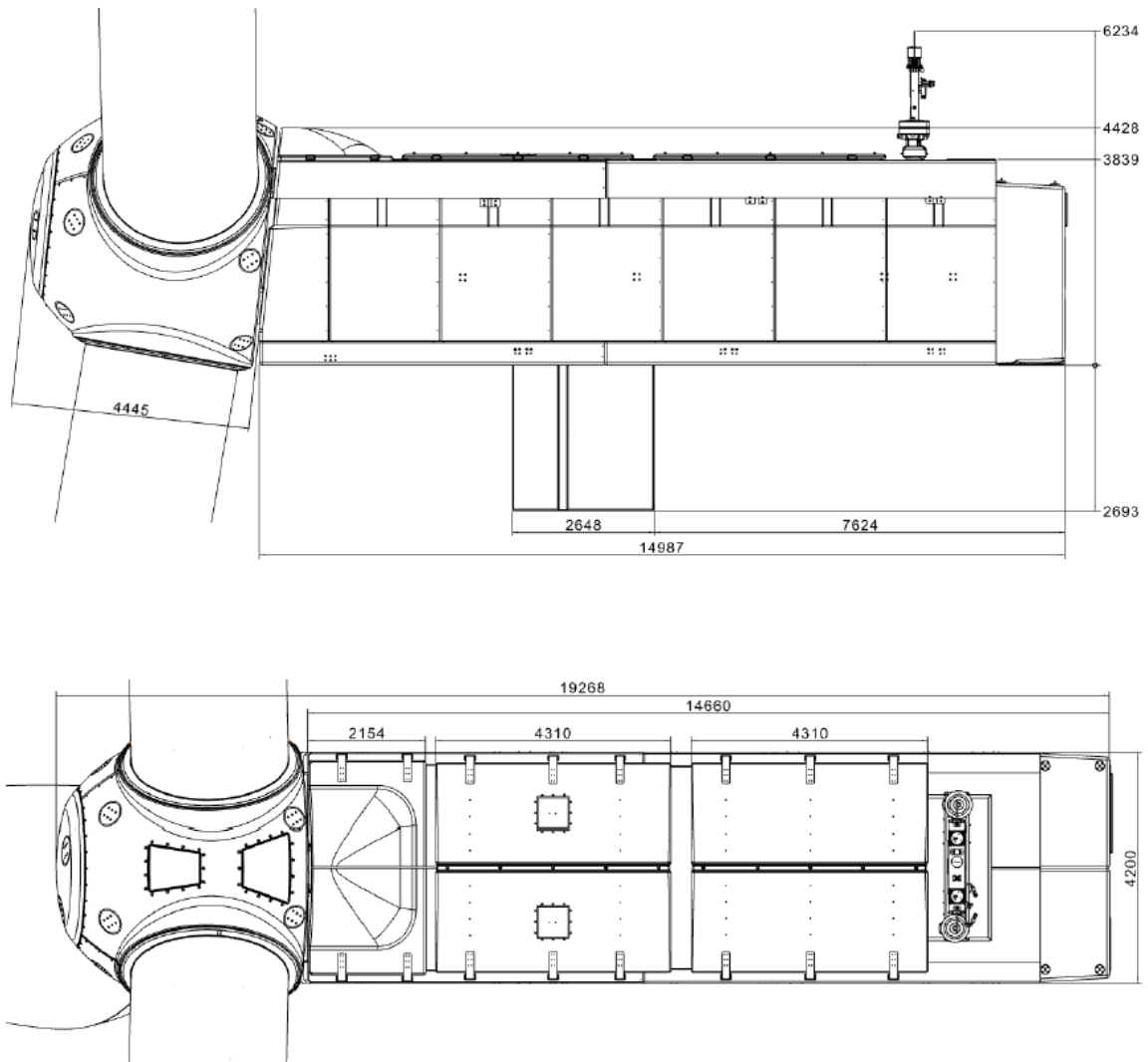

Several modularized solutions are designed to optimize nacelle and hub transportation, subject to project specific conditions.

- 3 modules (heaviest module <95t): Hub, nacelle, drive train
- 4 modules (heaviest module <79t): Hub, nacelle, drive train, transformer
- 6 modules (heaviest module <62t): Hub, nacelle, gearbox, main shaft, transformer and generator

Preliminary Elevation Drawing

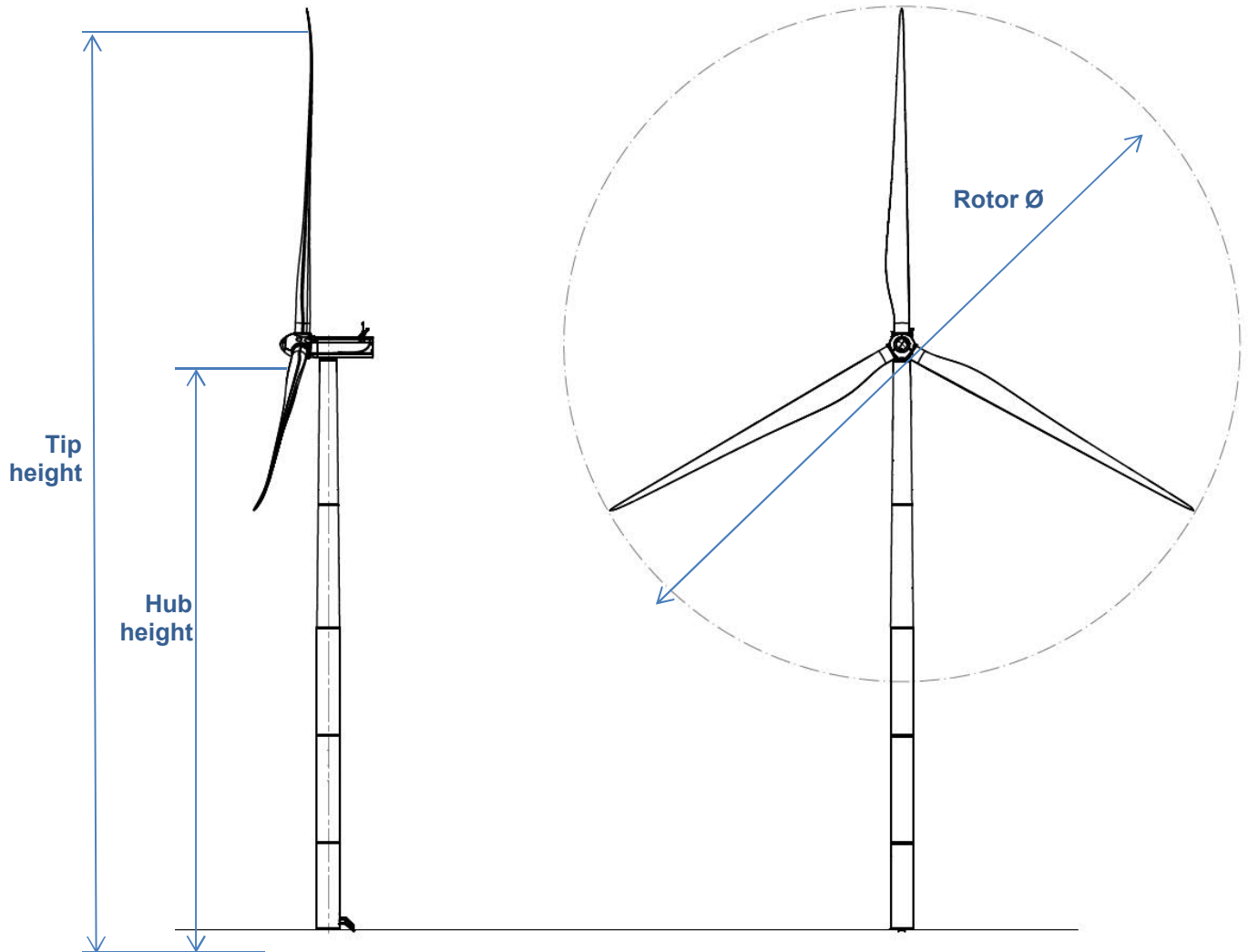

Blade Sales Drawing

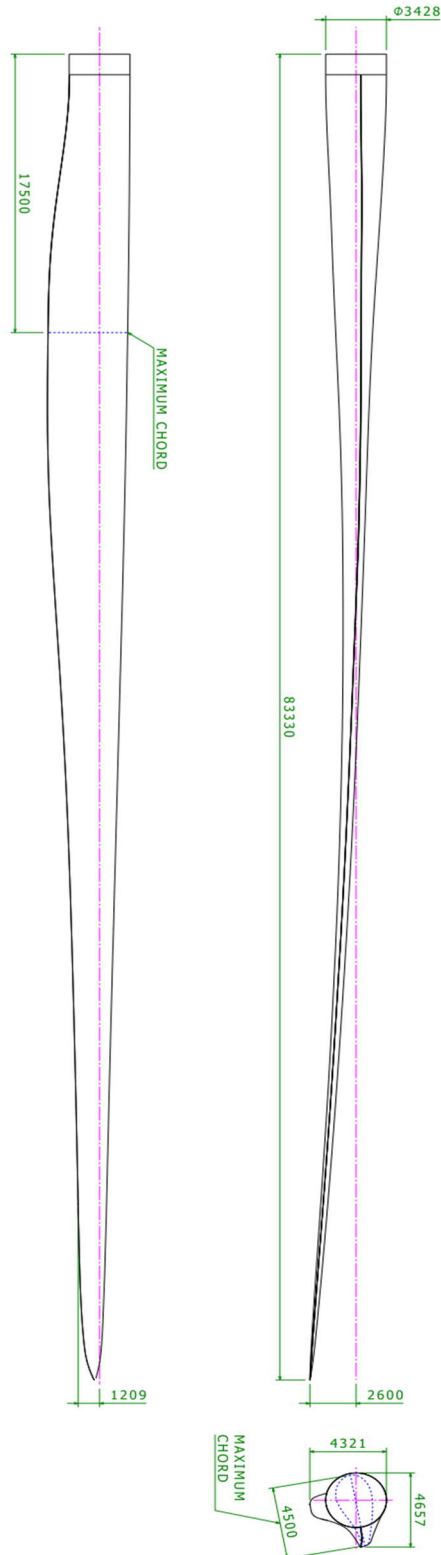

Tower dimensions

SG 6.0-170 is offered with an extensive tower portfolio ranging from 100 m - 165 m, including the baseline 115 m and 165 m catalogue towers. All towers are designed in compliance with local logistics requirements.

Preliminary information:

- Tower hub height 115 m IIIA. Tapered tubular steel tower.

	Section 1	Section 2	Section 3	Section 4	Section 5
External diameter upper flange (m)	4.700	4.436	4.427	4.021	3.503
External diameter lower flange (m)	4.700	4.700	4.436	4.427	4.021
Section's height (m)	13.564	18.200	23.800	26.880	29.970
Total weight (T)	84.958	84.328	84.548	71.771	63.863
Volume (CBM)	228	363	470	584	498

- Tower hub height 165 m IIIA. Hybrid design (concrete + steel)

	Concrete Section 1	Steel Section 2	Steel Section 3	Steel Section 4
External diameter upper flange (m)	4.668	4.300	4.300	3.574
External diameter lower flange (m)	7.888	4.300	4.,300	4.300
Section's height (m)	100.29	17.970	21.385	21.531

Information about other tower heights and logistic will be available upon request.

Foundation Dimensions and loads

The SG 6.0-170 foundation design inputs for T115 can be found on the following documents: D2372547.

Foundation loads inputs for T115 m can be found on the following document: D2370721

Detailed information about foundation loads will be available upon request

Design Climatic Conditions

The design climatic conditions are the boundary conditions at which the turbine can be applied without supplementary design review. Applications of the wind turbine in more severe conditions may be possible, depending upon the overall circumstances. A project site-specific review requires that the Employer complete the “Project Climatic Conditions” form.

All references made to standards such as the IEC and ISO are further specified in the document “Codes and Standards”. The design lifetime presented in the below table only applies to the fatigue load analysis performed in accordance with the presented IEC code. The term design lifetime and the use thereof do not constitute any express and/or implied warranty for actual lifetime and/or against failures on the wind turbines. Please see document for “design lifetime of wind turbine components” for more information.

Subject	ID	Issue	Unit	Value	
0. Design lifetime	0.0	Design lifetime definition	-	IEC 61400-1 ¹	
	0.1	Design lifetime	years	20	25
1. Wind, operation	1.1	Wind definitions	-	IEC 61400-1	
	1.2	IEC class	-	IIIA	IIIB
	1.3	Mean air density, ρ	kg/m ³	1.225	1.225
	1.4	Mean wind speed, V_{ave}	m/s	7.5	7.5
	1.5	Weibull scale parameter, A	m/s	8.46	8.46
	1.6	Weibull shape parameter, k	-	2	2
	1.7	Wind shear exponent, α	-	0.20	0.20
	1.8	Reference turbulence intensity at 15 m/s, I_{ref}	-	0.16	0.14
	1.9	Standard deviation of wind direction	Deg	-	-
	1.10	Maximum flow inclination	Deg	8	8
	1.11	Minimum turbine spacing, in rows	D	-	-
	1.12	Minimum turbine spacing, between rows	D	-	-
2. Wind, extreme	2.1	Wind definitions	-	IEC 61400-1	
	2.2	Air density, ρ	kg/m ³	1.225	
	2.3	Reference wind speed average over 10 min at hub height, V_{ref}	m/s	37.5	
	2.4	Maximum 3 s gust in hub height, V_{e50}	m/s	52.5	
	2.5	Maximum hub height power law index, α	-	0.11	
	2.6	Storm turbulence	-	N/A	
3. Temperature	3.1	Temperature definitions	-	IEC 61400-1	
	3.2	Minimum temperature, stand-still, $T_{min, s}$	Deg.C	-30	
	3.3	Minimum temperature, operation, $T_{min, o}$	Deg.C	-20	
	3.4	Maximum temperature, operation, $T_{max, o}$	Deg.C	40 ²	
	3.5	Maximum temperature, stand-still, $T_{max, s}$	Deg.C	50	
4. Corrosion	4.1	Atmospheric-corrosivity category definitions	-	ISO 12944-2	
	4.2	Internal nacelle environment (corrosivity category)	-	C3H (std) ≥C3H (high C)	
	4.3	Exterior environment (corrosivity category)	-	C3H (std) ≥C3H (high C)	
5. Lightning	5.1	Lightning definitions	-	IEC61400-24:2010	
	5.2	Lightning protection level (LPL)	-	LPL 1	

¹ All mentioning of IEC 61400-1 refers to IEC 61400-1:2018 Ed4.

² Maximum power output may be limited after an extended period of operation with a power output close to nominal power. The limitation depends on air temperature and air density as further described in the High Temperature Ride Through specification.

Subject	ID	Issue	Unit	Value
6. Dust	6.1	Dust definitions	-	IEC 60721-3-4:1995
	6.2	Working environmental conditions	mg/m ³	Average Dust Concentration (95% time) → 0.05 mg/m ³
	6.3	Concentration of particles	mg/m ³	Peak Dust Concentration (95% time) → 0.5 mg/m ³
7. Hail	7.1	Maximum hail diameter	mm	20
	7.2	Maximum hail falling speed	m/s	20
8. Ice	8.1	Ice definitions	-	-
	8.2	Ice conditions	Days/yr	7
9. Solar radiation	9.1	Solar radiation definitions	-	IEC 61400-1
	9.2	Solar radiation intensity	W/m ²	1000
10. Humidity	10.1	Humidity definition	-	IEC 61400-1
	10.2	Relative humidity	%	Up to 95
11. Obstacles	11.1	If the height of obstacles within 500m of any turbine location height exceeds 1/3 of (H – D/2) where H is the hub height and D is the rotor diameter then restrictions may apply. Please contact Siemens Gamesa Renewable Energy for information on the maximum allowable obstacle height with respect to the site and the turbine type.		
12. Precipitation³	12.1	Annual precipitation	mm/yr	1100

³ The specified maximum precipitation considers standard liquid Leading Edge Protection. For sites with higher annual precipitation and/or longer lifetime, it is recommended to consider optional reinforced Leading Edge Protection.

Flexible Rating Specifications

The SG 6.0-170 is offered with various operational modes that are achieved through the flexible operating capacity of the product, enabling the configuration of an optimal power rating that is best suited for each wind farm. The operating modes are broadly divided into two categories: Application Modes and Noise Reduction System Modes⁴.

Application Modes

Application Modes ensure optimal turbine performance with maximum power rating allowed by the structural and electrical systems of the turbine. There are multiple Application Modes, offering flexibility of different power ratings. All Application Modes are part of the turbine Certificate.

SG 6.0-170 can offer increased operation flexibility with modes based on AM 0 with reduced power rating. These new modes are created with same noise performance of the corresponding Application Mode 0 but with decreased rating and improved temperature de-rating than the corresponding Application Mode 0. In addition, the turbine's electrical performance is constant for the full set of application modes, as shown on the table below.

The SG 6.0-170 is designed with a base wind class, applicable to AM 0, of IEC IIIA for 20 year lifetime as well as IEC IIIB for 25 year lifetime. All other Application Modes may be analysed for more demanding site conditions.

Full List of Application Modes

Rotor Configuration	Application mode	Rating [MW]	Noise [dB(A)]	Power Curve Document	Acoustic Emission Document	Electrical Performance			Max temperature With Max active power and electrical capabilities ⁵
						Cos Phi	Voltage Range	Frequency range	
SG 6.0-170	AM 0	6.2	106	D2075729	D2359593	0.9	[0.95, 1.12] Un	±3% Fn	30°C
SG 6.0-170	AM-1	6.1	106	D2356499	D2359593	0.9	[0.95, 1.12] Un	±3% Fn	33°C
SG 6.0-170	AM-2	6.0	106	D2356509	D2359593	0.9	[0.95, 1.12] Un	±3% Fn	35°C
SG 6.0-170	AM-3	5.9	106	D2356523	D2359593	0.9	[0.95, 1.12] Un	±3% Fn	37°C
SG 6.0-170	AM-4	5.8	106	D2356539	D2359593	0.9	[0.95, 1.12] Un	±3% Fn	38°C
SG 6.0-170	AM-5	5.7	106	D2356376	D2359593	0.9	[0.95, 1.12] Un	±3% Fn	39°C
SG 6.0-170	AM-6	5.6	106	D2356368	D2359593	0.9	[0.95, 1.12] Un	±3% Fn	40°C

⁴ It should be noted that the definition of various modes as described in this chapter is applicable in combination with standard temperature limits and grid capabilities of the turbine. Please refer to High Temperature Power De-rating Specification and Reactive Power Capability Document for more information

⁵ Please Refer to "High Temperature Power De-rating Specification" for more details'

Noise Reduction System (NRS) Modes

The Noise Reduction System is an optional module available with the basic SCADA configuration and it therefore requires the presence of a SGRE SCADA system to work. NRS Modes are noise curtailed modes enabled by the Noise Reduction System. The purpose of this system is to limit the noise emitted by any of the functioning turbines and thereby comply with local regulations regarding noise emissions.

Noise control is achieved through the reduction of active power and rotational speed of the wind turbine. This reduction is dependent on the wind speed. The Noise Reduction System controls the noise settings of each turbine to the most appropriate level at all times, in order to keep the noise emissions within the limits allowed. Sound Power Levels correspond to the wind turbine configuration equipped with noise reduction add-ons attached to the blade.

The activation of NRS modes depend on the tower type selection. This information can be provided upon request.

Rotor Configuration	NRS Mode	Rating [MW]	Noise [dB(A)]	Power Curve Document	Acoustic Emission Document	Max temperature With Max active power and electrical capabilities ⁶
SG 6.0-170	N1	6.00	105.5	D2323420	D2359593	30°C
SG 6.0-170	N2	5.80	104.5	D2314784	D2359593	30°C
SG 6.0-170	N3	5.24	103.0	D2314785	D2359593	30°C
SG 6.0-170	N4	5.12	102.0	D2314786	D2359593	30°C
SG 6.0-170	N5	4.87	101.0	D2314787	D2359593	30°C
SG 6.0-170	N6	4.52	100.0	D2314788	D2359593	30°C
SG 6.0-170	N7	3.60	99.0	D2314789	D2359593	30°C

Control Strategy

The Application Modes are implemented and controlled in the Wind Turbine Controller. The NRS modes are also handled in the SCADA, however it shall also be possible to deploy custom NRS modes from the SCADA to the Wind Turbine Controller.

⁶ Please refer to "High Temperature Power De-rating Specification" for more details'.

Electrical Specifications

Nominal output and grid conditions

Nominal power	6200 kW
Nominal voltage	690 V
Power factor correction.....	Frequency converter control
Power factor range.....	0.9 capacitive to 0.9 inductive at nominal balanced voltage

Generator

Type	DFIG Asynchronous
Maximum power.....	6350 kW @30°C ext. ambient

Nominal speed.....	1120 rpm-6p (50Hz) 1344 rpm-6p (60Hz)
--------------------	--

Generator Protection

Insulation class	Stator H/H Rotor H/H
Winding temperatures	6 Pt 100 sensors
Bearing temperatures.....	3 Pt 100
Slip Rings	1 Pt 100
Grounding brush.....	On side no coupling

Generator Cooling

Cooling system	Air cooling
Internal ventilation	Air
Control parameter	Winding, Air, Bearings temperatures

Frequency Converter

Operation.....	4Q B2B Partial Load
Switching	PWM
Switching freq., grid side...	2.5 kHz
Cooling	Liquid/Air

Main Circuit Protection

Short circuit protection.....	Circuit breaker
Surge arrester.....	varistors

Peak Power Levels

10 min average	Limited to nominal
----------------------	--------------------

Grid Capabilities Specification

Nominal grid frequency	50 or 60 Hz
Minimum voltage.....	85 % of nominal
Maximum voltage.....	113 % of nominal
Minimum frequency.....	92 % of nominal
Maximum frequency.....	108 % of nominal
Maximum voltage imbalance (negative sequence of component voltage)	≤5 %
Max short circuit level at controller's grid	
Terminals (690 V)	82 kA

Power Consumption from Grid (approximately)

At stand-by, No yawing	10 kW
At stand-by, yawing.....	50 kW

Controller back-up

UPS Controller system.....	Online UPS, Li battery
Back-up time	1 min
Back-up time Scada.....	Depend on configuration

Transformer Specification

Transformer impedance requirement	8.5 % - 10.5%
Secondary voltage.....	690 V
Vector group.....	Dyn 11 or Dyn 1 (star point earthed)

Earthing Specification

Earthing system.....	Acc. to IEC62305-3 ED 1.0:2010
Foundation reinforcement .	Must be connected to earth electrodes
Foundation terminals	Acc. to SGRE Standard

HV connection	HV cable shield shall be connected to earthing system
---------------------	---

All data are subject to tolerances in accordance with IEC.

Simplified Single Line Diagram

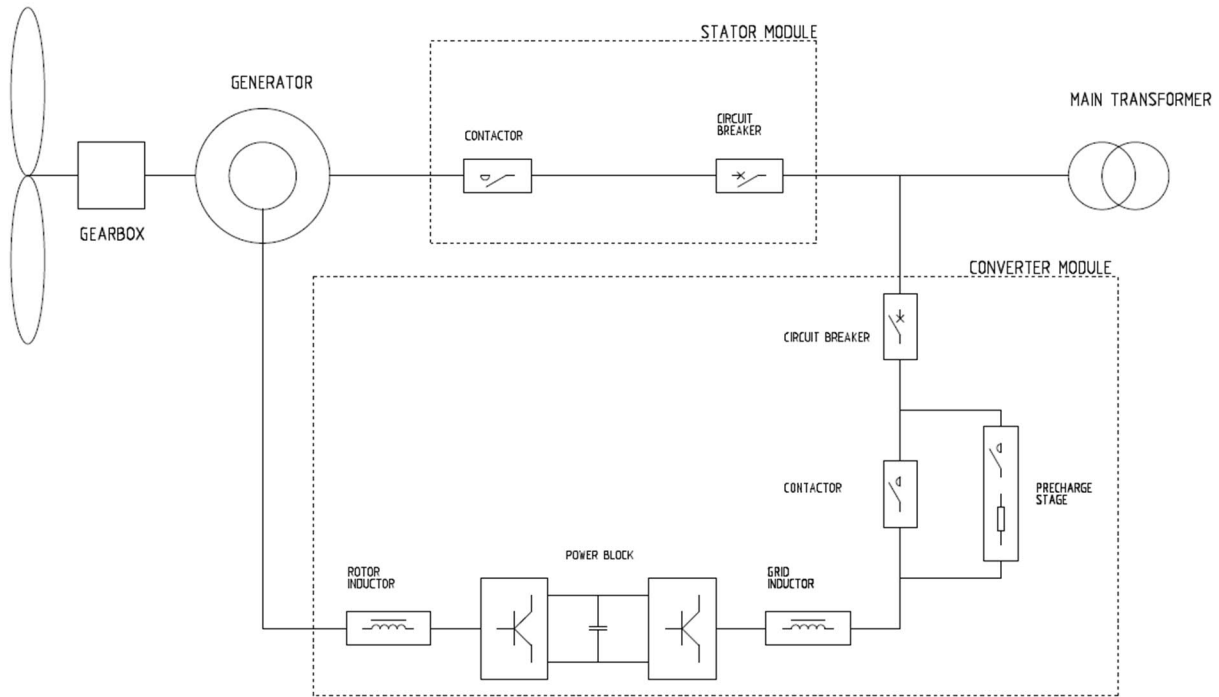

Transformer Specifications ECO 30 kV

Transformer

Type	Liquid filled
Max Current	7.11 kA + harmonics at nominal voltage $\pm 10\%$
Nominal voltage	30/0.69 kV
Frequency	50 Hz
Impedance voltage	9.5% $\pm 8.3\%$ at ref. 6.5 MVA
Loss ($P_0/P_{k75^\circ C}$)	4.77/84.24 kW
Vector group	Dyn11
Standard	IEC 60076 ECO Design Directive

Transformer Monitoring

Top oil temperature	PT100 sensor
Oil level monitoring sensor	Digital input
Overpressure relay	Digital input

Transformer Cooling

Cooling type	KFWF
Liquid inside transformer	K-class liquid
Cooling liquid at heat exchanger	Glycantin

Transformer Earthing

Star point	The star point of the transformer is connected to earth
------------------	---

Switchgear Specifications

General

The switchgear will be chosen as factory-assembled, type-tested, and maintenance-free high-voltage switchgear with single-busbar system. The device will be metal-enclosed, metal-clad, gas-isolated, and conforms to the stipulations of IEC 62271-200.

The switchgear vessel of the gas-insulated switchgear is classified according to IEC as a “sealed pressure system”. It is gas-tight for life. The switchgear vessel accommodates the busbar system and switching device (such as vacuum circuit breaker, three-position switch disconnecting and earthing). The vessel is filled with sulphur hexafluoride (SF₆) at the factory. This gas is non-toxic, chemically inert, and features a high dielectric strength. Gas work on site is not required, and even in operation it is not necessary to check the gas condition or refill, the vessel is designed for being gas tight for life.

To monitor the gas density, every switchgear vessel is equipped with a ready-for-service indicator at the operating front. This is a mechanical red/green indicator, self-monitoring and independent of temperature and variations of the ambient air pressure.

MV cables connected to the grid cable- and circuit-breaker feeders are connected via cast-resin bushings leading into the switchgear vessel. The bushings are designed as outside-cone system type “C” M16 bolted 630 A connections according to EN 50181. The compartment is accessible from the front. A mechanical interlock ensures that the cable compartment cover can only be removed when the three-position switch is in the earthed position.

The circuit-breaker operates based on vacuum switching technology. The vacuum interrupter unit is installed in the switchgear vessel together with the three-position switch and is thus protected from environmental influences. The operating mechanism of the circuit-breaker is located outside the vessel. Both, the interrupters and the operating mechanisms, are maintenance-free.

Padlock facilities are provided to lock the switchgear from operation in disconnecter open and close position, earth switch open and close position, and circuit breaker open position, to prevent improper operation of the equipment.

Capacitive Voltage detection systems are installed both in the grid cable and the circuit breaker feeders. Pluggable indicators can be plugged at the switchgear front to show the voltage status.

The switchgear is equipped with an over-current protection relay with the functions over current, short circuit and earth fault protection. The relay ensures that the transformer is disconnected if a fault occurs in the transformer or the high voltage installation in the wind turbine. The relay is adjustable to obtain selectivity between low voltage main breaker and the circuit breaker in the substation.

The protective system shall cause the circuit breaker opening with a dual powered relay (self-power supply + external auxiliary power supply possibility). It imports its power supply from current transformers, that are already mounted on the bushings inside the circuit breaker panel and is therefore ideal for wind turbine applications.

Trip signals from the transformer auxiliary protection and wind turbine controller can also disconnect the switchgear.

The switchgear consists of two or more feeders*; one circuit breaker feeder for the wind turbine transformer also with earthing switch and one or more grid cable feeders** with load break switch and earthing switch.

The switchgear can be operated local at the front or by use of portable remote control (circuit breaker only) connected to a control box at the wind turbine entrance level.

* Up to four feeders.

** SGRE to be contacted for possible feeder configurations of circuit breaker and grid feeder combinations.

The switchgear is located below the tower structure. The main transformer, LV switchgear and converters are located on the nacelle level above the tower.

Grid cables, from substation and/or between the turbines, must be installed at the bushings in the grid cable feeder cubicles of the switchgear. These bushings are the interface/grid connection point of the turbine. It is possible to connect grid cables in parallel by installing the cables on top of each other. The space in the MV cable compartments of the switchgear allows the installation of two connectors per phase or one connector + surge arrester per phase.

The transformer cables are installed at the bottom of the circuit breaker feeder. The cable compartment is accessible from the front. A mechanical interlock ensures that the cable compartment cover can only be removed when the three-position switch is in the earthed position.

Optionally, the switchgear can be delivered with surge arresters installed in between the switchgear and wind turbine transformer on the outgoing bushings of the circuit breaker feeder.

Technical Data for Switchgear

Switchgear

Make	TBD
Type	TBD
Rated voltage	20-40,5(Um) kV
Operating voltage	20-40,5(Um) kV
Rated current	630 A
Short time withstand current	20 kA/1s
Peak withstand current	50 kA
Power frequency withstand voltage	70 kV
Lightning withstand voltage	170 kV
Insulating medium	SF ₆
Switching medium	Vacuum
Consist of	2/3/4 panels
Grid cable feeder	Cable riser or line cubicle
Circuit breaker feeder	Circuit breaker
Degree of protection, vessel	IP65
Internal arc classification IAC:	A FL 20 kA 1s
Pressure relief	Downwards
Standard	IEC 62271
Temperature range	-25°C to +45°C

Grid cable feeder (line cubicle)

Rated current, Cubicle	630 A
Rated current, load breaker	630 A
Short time withstand current	20 kA/1s
Short circuit making current	50 kA/1s
Three position switch	Closed, open, earthed
Switch mechanism	Spring operated
Control	Local
Voltage detection system	Capacitive

Circuit breaker feeder

Rated current, Cubicle	630 A
Rated current circuit breaker	630 A
Short time withstand current	20 kA/1s
Short circuit making current	50 kA/1s
Short circuit breaking current	20 kA/1s
Three position switch	Closed, open, earthed
Switch mechanism	Spring operated
Tripping mechanism	Stored energy
Control	Local
Coil for external trip	230V AC
Voltage detection system	Capacitive

Protection

Over-current relay	Self-powered
Functions	50/51 50N/51N
Power supply	Integrated CT supply

Interface- MV Cables

Grid cable feeder	630 A bushings type C M16 Max 2 feeder cables
Cable entry	From bottom
Cable clamp size (cable outer diameter) **	26 - 38mm 36 - 52mm 50 - 75mm
Circuit breaker feeder	630 A bushings type C
Cable entry	M16 From bottom
Interface to turbine control	
Breaker status	
SF6 supervision	1 NO contact
External trip	1 NO contact

*Cable clamps are not part of switchgear delivery.

Grid Performance Specification, 50 Hz

This document describes the grid performance of the Siemens Gamesa 5.X, 50 Hz wind turbine. Siemens Gamesa Renewable Energy (SGRE) will provide wind turbine technical data for the developer to use in the design of the wind power plant and the evaluation of requirements compliance. The developer will be responsible for the evaluation and ensuring that the requirements are met for the wind power plant.

The capabilities described in this document are based on the assumption that the electrical network is designed to be compatible with operation of the wind turbine. SGRE will provide a document with guidance to perform an assessment of the network's compatibility.

Fault Ride Through (FRT) Capability

The wind turbine is capable of operating when voltage transient events occur on the interconnecting transmission system above and below the standard voltage lower limits and time slot according to Figure 1 and Figure 2.

This performance assumes that the installed amount of wind turbines is in the right proportion to the strength of the grid, which means that the short circuit ratio (S_k/S_n) and the X/R ratio of the grid at the wind turbine transformer terminals must be adequate.

Evaluation of the wind turbine's fault ride through capability in a specific system must be based on simulation studies using the specific network model and a dynamic wind turbine model provided by SGRE. This model is a reduced order model, suitable for balanced simulations with time steps between 4-10 ms.

The standard voltage limits for the Siemens Gamesa 5.X, 50 Hz wind turbine are presented in Figure 1 between 0 - 70 seconds.

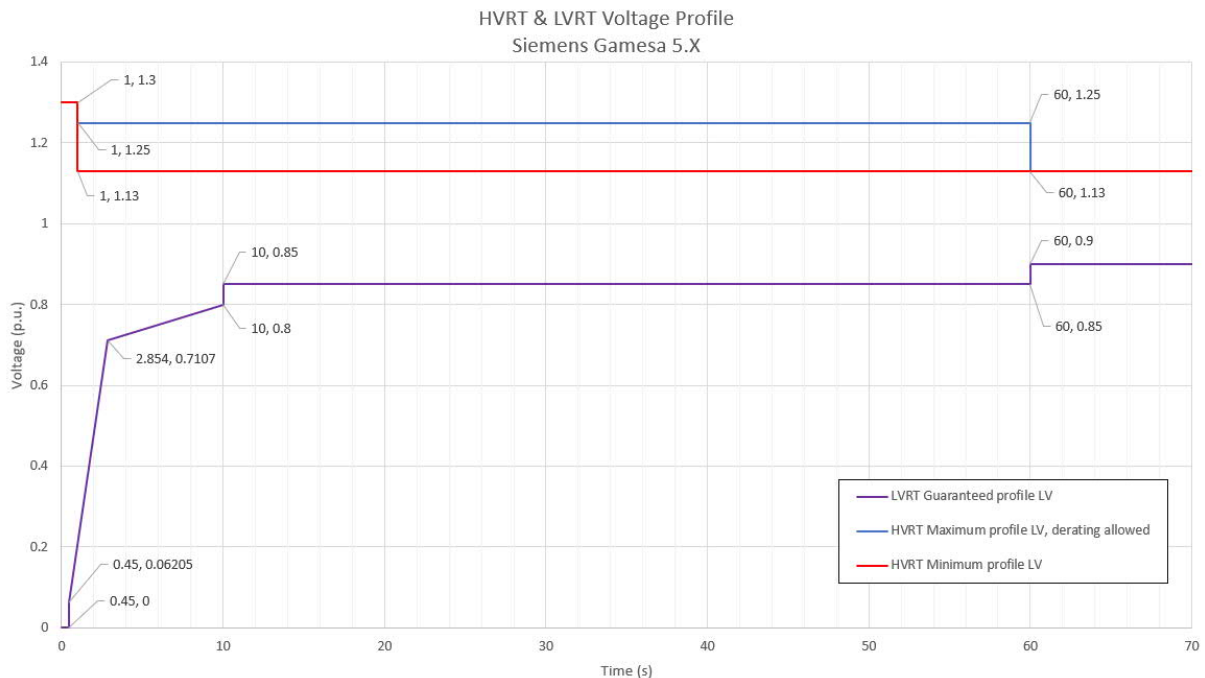

Figure 1. High and Low voltage limits for Siemens Gamesa 5.X, 50 Hz wind turbine in the range of 0-70 seconds. The nominal voltage is 690 V (i.e. 1 p.u.).

Power Factor (Reactive Power) Capability

The wind turbine can operate in a power factor range of 0.9 leading to 0.9 lagging at the low voltage side of the wind turbine transformer, considering a voltage level equal or higher of 0.95pu. Depending on the voltage behaviour (higher or lower, inside maximum permissible margins), the Reactive Power maximum capability is modified accordingly.

The control mode for the wind turbine is with reactive power set-points or Local Voltage Control mode (external set-points of voltage).

Supervisory Control and Data Acquisition (SCADA) Capability

The SGRE SCADA system has the capability to transmit and receive instructions from the transmission system provider for system reliability purposes depending on the configuration of the SCADA system. The project specific SCADA requirements must be specified in detail for design purposes.

Frequency Capability

The wind turbine can operate in the frequency range between 46 Hz and 54 Hz, making a difference between a steady state operation (full simultaneity): $\pm 3\%$, and transients' events (limited simultaneity): $\pm 8\%$, over rated frequency.

Simultaneities of main operation parameters shall be considered for evaluating the permitted operation ranges, mainly:

- Active Power level
- Reactive Power provision
- Ambient Temperature
- Voltage level of operation
- Frequency level of operation

And the total time that the turbine is operating under such conditions.

Voltage Capability

The voltage operation range for the wind turbine is between 85% and 113% of nominal voltage at the low voltage side of the wind turbine transformer. The voltage can be up to 130% for 1s, see Figure 1. The wind turbine's target voltage shall stay between 95% and 105% to support the best possible performance by staying within the operation limits.

Beyond $\pm 10\%$ of voltage deviation, automatic voltage support algorithms could execute Reactive Power control, to secure a continuous operation of the Wind Turbine Generator and maximizing the availability, overriding external control and setpoints of Reactive Power.

Flicker and Harmonics

Flicker and Harmonics values will be provided in the power quality measurement report extract in accordance with IEC 61400-21 Edition 2.

Reactive Power -Voltage Control

The power plant controller can operate in two different modes:

- Q Control – In this mode reactive power is controlled at the point of interconnection, according to a reactive power reference
- V Control – Voltage is directly controlled at the point of interconnection, according to a voltage reference

The SCADA system receives feedback/measured values from the Point of Interconnection depending on the control mode it is operating. The wind power plant controller then compares the measured values against the target levels and calculates the reactive power/voltage reference. Finally, references are distributed to each individual wind turbine. The wind turbine's controller responds to the latest reference from the SCADA system and will generate the required response accordingly from the wind turbine.

Frequency Control

The frequency control is managed by the SCADA system together with the wind turbine controller. The wind power plant frequency control is carried out by the SCADA system which distributes active power set-points to each individual wind turbine, to the controllers. The wind turbine controller responds to the latest reference from the SCADA system and will maintain this active power locally.

All data are subject to tolerances in accordance with IE

Grid Performance Specification, 60 Hz

This document describes the grid performance of the SG5.X, 60 Hz wind turbine. Siemens Gamesa Renewable Energy (SGRE) will provide wind turbine technical data for the developer to use in the design of the wind power plant and the evaluation of requirements compliance. The developer will be responsible for the evaluation and ensuring that the requirements are met for the wind power plant.

The capabilities described in this document are based on the assumption that the electrical network is designed to be compatible with operation of the wind turbine. SGRE will provide a document with guidance to perform an assessment of the network's compatibility.

Fault Ride Through (FRT) Capability

The wind turbine is capable of operating when voltage transient events occur on the interconnecting transmission system above and below the standard voltage lower limits and time slot according to Figure 1 and Figure 2.

This performance assumes that the installed amount of wind turbines is in the right proportion to the strength of the grid, which means that the short circuit ratio (Sk/Sn) and the X/R ratio of the grid at the wind turbine transformer terminals must be adequate.

Evaluation of the wind turbine's fault ride through capability in a specific system must be based on simulation studies using the specific network model and a dynamic wind turbine model provided by SGRE. This model is a reduced order model, suitable for balanced simulations with time steps between 4-10 ms.

The standard voltage limits for the Siemens Gamesa 5.X, 60 Hz wind turbine are presented in Figure 1 between 0 - 70 seconds.

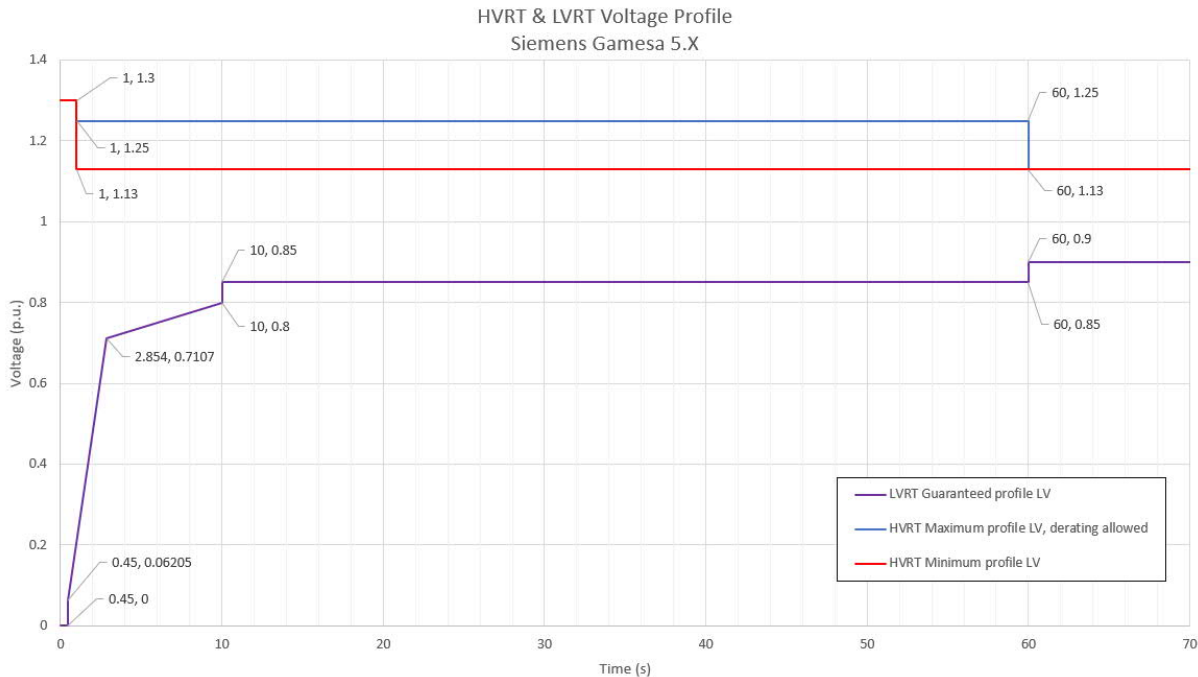

Figure 1. High and Low voltage limits for Siemens Gamesa 5.X, 60 Hz wind turbine in the range of 0-70 seconds. The nominal voltage is 690 V (i.e. 1 p.u.).

Power Factor (Reactive Power) Capability

The wind turbine can operate in a power factor range of 0.9 leading to 0.9 lagging at the low voltage side of the wind turbine transformer, considering a voltage level equal or higher of 0.95pu. Depending on the voltage behaviour (higher or lower, inside maximum permissible margins), the Reactive Power maximum capability is modified accordingly.

The control mode for the wind turbine is with reactive power set-points or Local Voltage Control mode (external set-points of voltage).

Supervisory Control and Data Acquisition (SCADA) Capability

The SGRE SCADA system has the capability to transmit and receive instructions from the transmission system provider for system reliability purposes depending on the configuration of the SCADA system. The project specific SCADA requirements must be specified in detail for design purposes.

Frequency Capability

The wind turbine can operate in the frequency range between 55.2 Hz and 64.8 Hz, making a difference between a steady state operation (full simultaneity): $\pm 3\%$, and transients' events (limited simultaneity): $\pm 8\%$, over rated frequency.

Simultaneities of main operation parameters shall be considered for evaluating the permitted operation ranges, mainly:

- Active Power level
- Reactive Power provision
- Ambient Temperature
- Voltage level of operation
- Frequency level of operation

And the total time that the turbine is operating under such conditions.

Voltage Capability

The voltage operation range for the wind turbine is between 85% and 113% of nominal voltage at the low voltage side of the wind turbine transformer. The voltage can be up to 130% for 1s, see Figure 1. The wind turbine's target voltage shall stay between 95% and 105% to support the best possible performance by staying within the operation limits.

Beyond $\pm 10\%$ of voltage deviation, automatic voltage support algorithms could execute Reactive Power control, to secure a continuous operation of the Wind Turbine Generator and maximizing the availability, overriding external control and setpoints of Reactive Power.

Flicker and Harmonics

Flicker and Harmonics values will be provided in the power quality measurement report extract in accordance with IEC 61400-21 Edition 2.

Reactive Power -Voltage Control

The power plant controller can operate in two different modes:

- Q Control – In this mode reactive power is controlled at the point of interconnection, according to a reactive power reference
- V Control – Voltage is directly controlled at the point of interconnection, according to a voltage reference

The SCADA system receives feedback/measured values from the Point of Interconnection depending on the control mode it is operating. The wind power plant controller then compares the measured values against the target levels and calculates the reactive power/voltage reference. Finally, references are distributed to each individual wind turbine. The wind turbine's controller responds to the latest reference from the SCADA system and will generate the required response accordingly from the wind turbine.

Frequency Control

The frequency control is managed by the SCADA system together with the wind turbine controller. The wind power plant frequency control is carried out by the SCADA system which distributes active power set-points to each individual wind turbine, to the controllers. The wind turbine controller responds to the latest reference from the SCADA system and will maintain this active power locally.

Reactive Power Capability, 50 and 60 Hz

This document describes the reactive power capability of SG 6.0-170, 50/60 Hz wind turbines during active power production. SG 6.0-170 wind turbines are equipped with a B2B Partial load frequency converter which allows the wind turbine to operate in a wide power factor range.

The maximum amount of Reactive Power to be generated or consumed depends on a wide range of parameters, some of them not possible to consider in a general way as they are fully dependent on the site and grid conditions.

Between others, the Reactive Power Capability at a given Operating Conditions depends on existing Active Power, internal temperature of Wind Turbine Generator components, external ambient temperature, Grid conditions (voltage level, frequency level, etc.) and impact, thermally, in high inertial systems. So, the required operation time in worse conditions is also a parameter to be considered.

Online maximum capabilities estimation is executed by the Reactive Power Controller algorithm, to provide the possibility of maximizing the Capabilities in favorable grid and site conditions.

Reactive Power Capability Curves

The estimated minimum reactive power capability for the wind turbine at the LV side of the wind turbine transformer will be presented in the following Figures.

Figure 1 shows the guaranteed reactive power capability depending on the generated Active Power at various voltages at the LV terminals, starting by 90% of rated voltage.

The reference external temperature is set to maximum (SG 6.0-170, 6.2MW, 30°C ext Temp).

Maximum capabilities when reducing ambient temperatures or increasing voltage level are higher but not shown in this document as specific studies shall be carried out in case of necessity.

Operation at voltages in between 86% to 90% over rated is considered a special situation where both Reactive Power and Active power may be de-rated depending on Operation Condition of the Wind Turbine Generator, especially dependent on the Ambient Temperature.

Between voltages of +112% and +113%, as well as between 85% and 86%, Reactive Power Controller enters in Voltage Saturation Mode and will not allow an amount of Reactive Power generation or consumption that would cause a self-trip due to over or under voltage protections, caused by the own operation of the turbine. These levels are possible to be set.

Figure 2 includes reactive power capability at no wind operating conditions (QwP0).

The SCADA can send voltage references to the wind turbine in the range of 0.92 p.u. to 1.08 p.u. The wind power plant should be designed to maintain the wind turbine voltage references between 0.95 p.u. and 1.05 p.u. during steady state operation.

The tables and figures assume that the phase voltages are balanced, and that the grid operational frequency and component values are nominal. Unbalanced voltages will decrease the reactive power capability. Component tolerances were not considered in determining curve parameters. Instead, the curves and data are subject to an overall tolerance of $\pm 5\%$ of the rated power.

These figures consider Wind Turbine operation around its expected generator speed for each operation condition. Extreme speed excursions caused by specific Wind gusts, up and down from standard value, may cause punctual Reactive Power restrictions due to Generator and Converter limits of voltage and currents. All this is also fully dependent on the Grid conditions of voltage level and external setpoint.

The guaranteed values of Reactive Power for those operational points in between the shown borders and corners of the figures, can be calculated by means of linear interpolation. Guaranteed values of Reactive Power in voltages over 0.95pu, are considered constant and fixed in the given values.

The reactive power capability presented in this document is the net capability and accounts for the contribution from the wind turbine auxiliary system, the reactors and the existing filters.

The reactive power capability described is valid while operating the wind turbine within the limits specified in the Design Climatic Conditions.

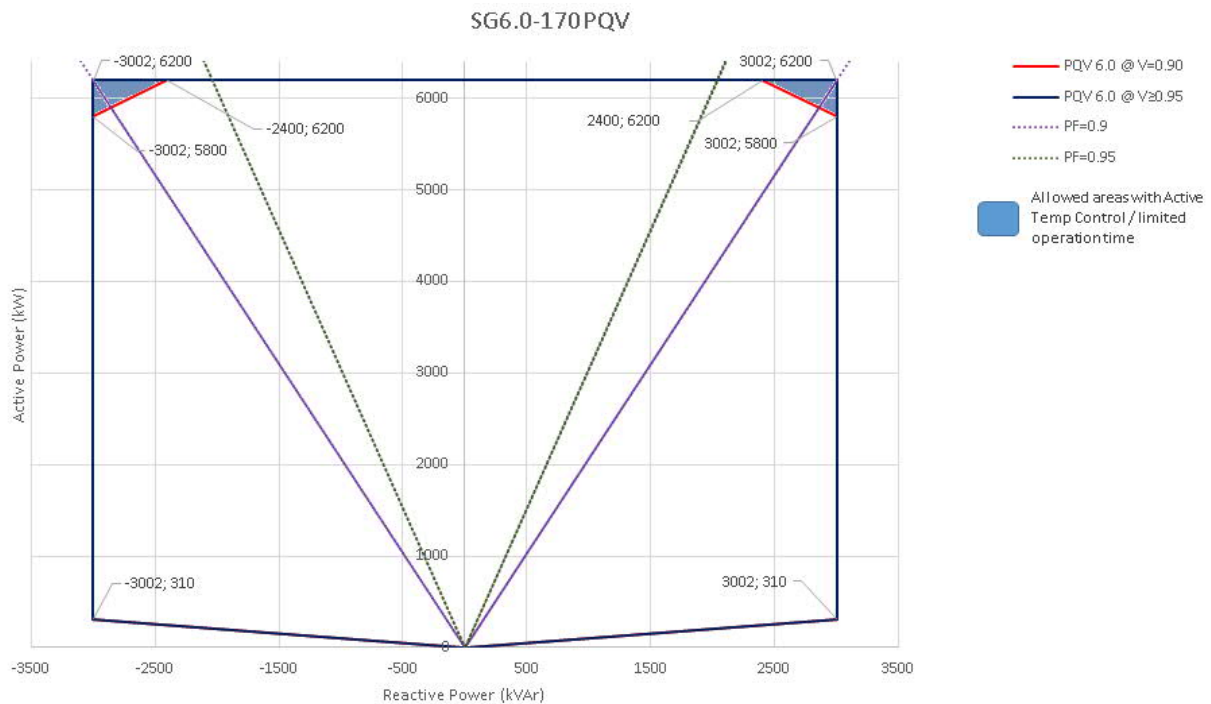

Figure 1: Reactive power capability curves, 50/60 Hz Wind Turbine, at LV terminals. External Ambient Temperature dependency included for Flex Rating operation description

SG 6.0-170 Prated = 6.2MW				
Active Power [kW]	V = 0.9pu		V ≥ 0.95pu	
	Reactive Power [kVAr]	Power Factor	Reactive Power [kVAr]	Power Factor
0	0 *	--*	0 *	--*
300	3002	0,9	3002	0,9
5800	3002	0,9	3002	0,9
6200	2400	0,933	3002	0,9

Table 1: Reactive power capability curves, 50/60 Hz Wind Turbine, at LV terminals. External Ambient Temperature dependency included for Flex Rating operation description

* Reactive Power at no wind conditions applies

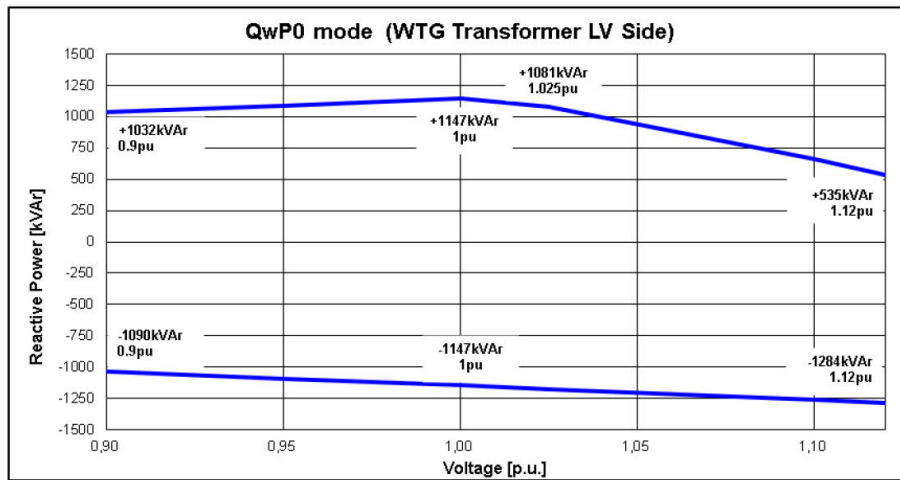

Figure 2: Reactive power capability at no wind (QwP0)

Using the standard Grid Transformer parameters, next table summarizes the expected Reactive Power Capability referenced to HV terminals when considering the Grid Transformer Reactive Power consumption and the declared LV PQV capability from Table 1.

Note: These values shall be used only as reference as are fully dependent on Grid Transformer variant, construction and brand. In general, it is considered that a deviation up to $\pm 10\%$ in Reactive Power consumption can exist between variants.

SG 6.0-170 Text = 30°C Prated = 6,2MW					
Active Power [% over rated]	Active Power [kW]	$V_{LV_side} = 0,9pu$		$V_{LV_side} \geq 0,95pu$	
		Reactive Power HV side [kVAr]		Reactive Power HV side [kVAr]	
0%	0	0 **	**	0 **	**
5%	300	2873	-3139	2873	-3139
16%	1000	2860	-3152	2860	-3152
24%	1500	2842	-3171	2842	-3171
32%	2000	2816	-3196	2816	-3196
40%	2500	2783	-3229	2783	-3229
48%	3000	2743	-3269	2743	-3269
56%	3500	2696	-3316	2696	-3316
65%	4000	2641	-3371	2641	-3371
73%	4500	2579	-3433	2579	-3433
81%	5000	2510	-3503	2510	-3503
89%	5500	2433	-3579	2433	-3579
94%	5800	2384	-3629	2384	-3629
100%	6200	1759	-3049	2314	-3699

Table 2: Reactive power capability curves, 50/60 Hz Wind Turbine, at HV terminals.

SCADA, System Description

The SGRE SCADA system is a system for supervision, data acquisition, control, and reporting for wind farm performance.

Main features

The SCADA system has the following main features:

- On-line supervision and control accessible via secured tunnel over the Internet.
- Data acquisition and storage of data in a historical database.
- Local storage of data at wind turbines if communication is interrupted and transferred to historical database when possible.
- System access from anywhere using a standard web browser. No special client software or licenses are required.
- Users are assigned individual usernames and passwords, and the administrator can assign a user level to each username for added security.
- Email function can be configured for fast alarm response for both turbine and substation alarms.
Configuration can also support alarm notification via SMS service.
- Interface to power plant control functions for enhanced control of the wind farm and for remote regulation, e.g. MW / Voltage / Frequency / Ramp rate.
- Interface for integration of substation equipment for monitoring and control.
- Interface for monitoring of Reactive compensation equipment, control of this equipment is achieved via the SGRE power plant controller
- Integrated support for environmental control such as noise, shadow/flicker, bat/wildlife and ice.
- Capabilities for monitoring hybrid power plant equipment such as Battery Energy Storage Systems (BESS) and Photo Voltaic (PV) systems. Control of such equipment is achieved via the SGRE power plant controller.
- Power curve plots and efficiency calculations with pressure and temperature correction (pressure and temperature correction available only if SGRE MET system supplied).
- Condition monitoring integrated with the turbine controller using designated server.
- Ethernet-based system with secure compatible interfaces (OPC UA / IEC 60870-5-104) for online data access.
- Legacy protocols like OPC-(XML)-DA or Modbus TCP can be supported on request
- Access to historical - scientific and optional high resolution data via Restfull API.
- Virus Protection Solution.
- Back-up & restore.

Wind turbine hardware

Components within the wind turbine are monitored and controlled by the individual local wind turbine controller (SICS). The SICS can operate the turbine independently of the SCADA system, and turbine operation can continue autonomously in case of, e.g. damage to communication cables.

Data recorded at the turbine is stored at the SICS. In the event that communication to the central server is temporarily interrupted data is kept in the SICS and transferred to the SCADA server when possible.

Communication network in wind farm

The communication network in the wind farm must be established with optical fibers. The optimum network design is typically a function of the wind farm layout. Once the layout is selected, SGRE will define the minimum requirements for the network design.

The supply, installation, and termination of the communication network are typically carried out by the Employer. If specifically agreed the division of responsibility for the communication network can be changed.

SCADA server panel

The central SCADA server panel supplied by SGRE is normally placed at the wind farm substation or control building. The server panel comprises amongst others:

- The server is configured with standard disk redundancy (RAID) to ensure continuous operation in case of disk failure. Network equipment. This includes all necessary switches and media converters.
- UPS back up to ensure safe shut down of servers in case of power outage.

For large sites or as option a virtualized SCADA solution can be supplied.

On the SCADA server the data is presented online as a web-service and simultaneously stored in an SQL database. From this SQL database numerous reports can be generated.

Employer "client" connection to the SCADA system establishing via the internet through a point to point TCP/IP VPN-connection.

Grid measuring station and Wind Farm Controller

The SCADA system includes a grid measuring station located in one / more module panels or in the SCADA server panel. Normally the grid measuring station is placed at the wind farm substation or control building.

The heart of the grid measuring station is a PQ meter. The Wind Farm Control /grid measuring station can be scaled to almost any arrangement of the grid connection. The grid measuring station requires voltage and current signals from VT's and CT's fitted at the wind farm PCC to enable the control functions.

The grid measuring station and the Wind Farm Control interfaces to the SGRE SCADA servers and turbines are via a LAN network.

The Wind Farm Control can on request be supplied in a high availability (HA) setup with a redundant server cluster configuration.

Note: In small SGRE SCADA systems (typically <10 turbines) and if the small SGRE SCADA system is placed in a turbine the Wind Farm Control and grid measuring station may be arranged otherwise.

Signal exchange

Online signal exchange and communications with third party systems such as substation control systems, remote control systems, and/or maintenance systems is possible from both the module and/or the SGRE SCADA server panel. For communication with third party equipment OPC UA and IEC 60870-5-104 are supported. Legacy protocols like OPC-(XML)-DA or Modbus TCP can be supported on request

SGRE SCADA software

The normal SGRE SCADA user interface presents online and historical data. The screen displays can be adjusted to meet individual customer requirements.

Historical data are stored in an MS SQL database as statistical values and can be presented directly on the screen or exported for processing in MS Access or via a RESTfull API.

The SGRE SCADA software can also serve as user interface to the Wind Farm Control functions.

Virus protection solution

A virus protection solution can be offered as a part of the Service Agreement (SA). An anti-virus client software will in that case be installed on all MS-Windows based components at the SCADA system and the WTGs.

The virus protection solution is based on a third-party anti-virus product. Updates to the anti-virus client software and pattern files are automatically distributed from central SGRE based servers.

Back-up & restore

For recovery of a defect SCADA system or component, the SGRE SCADA system provides back-up of configuration files and basic production data files. Both configuration and selected production data are backed up automatically on a regular time basis for major components. The back-up files are stored both locally on the site servers and remotely on SGRE back-up storage servers.

Codes and Standards

INTRODUCTION AND SCOPE

This document lists codes and standards according to which turbines are designed, manufactured and tested. The scope of this document is limited to the Siemens Gamesa 5.X platform.

CODES AND STANDARDS

SGRE Onshore geared turbines are designed, manufactured, and tested to SGRE's technical drawings, procedures, and processes that are generally in compliance with the applicable sections of the codes and standards listed herein. This list of codes and standards for design, manufacturing, and testing forms a part of the design basis documentation. The edition of the codes and standards is the version used for the certification process which is conducted by an external certifying body.

GENERAL

- IEC-RE Operational Document: OD-501, Type and Component Certification Scheme*
 - *IEC-RE is the substitute of IEC 61400-22:2010 Ed.1, Wind turbines – Part 22: Conformity testing and certification.
- *IEC 61400-1:2019 Ed.4 Wind turbines –. Part 1: Design requirements*
- *IEC 61400-11:2012 + AMD1:2018, Wind turbine generator systems Part 11: Acoustic noise measurement techniques*
- *IEC 61400-12-1:2017, Ed.1, Wind Turbine Generator Systems Part 12: Power performance measurements of electricity producing wind turbines*
- *IEC 61400-13: 2015 Wind Turbine Generator Systems - Part 13: Measurement of Mechanical Loads*
- *IEC 61400-23 Ed. 1.0 EN :2014 Wind turbines - Part 23: Full-scale structural testing of rotor blades*
- *EN 10025-1:2004, Hot rolled products of structural steels - Part 1: General technical delivery conditions*
- *EN 10025-2:2004, Hot rolled products of structural steels - Part 2: Technical delivery conditions for non-alloy structural steels*
- *EN 10025-3:2004, Hot rolled products of structural steels - Part 3: Technical delivery conditions for normalized/normalized rolled weldable fine grain structural steels*
- *EN 10029:2010, Hot rolled steel plates 3 mm thick or above - Tolerances on dimensions, shape and mass*
- *EN 10083:2006, Quenched and tempered steels - Part 1: Technical delivery conditions for special steels (Main shaft)*
- *EN 1563:2012, Founding - Spheroidal graphite cast irons*
- *EN 1993-1-8:2005/AC:2009: Eurocode 3: Design of steel structures Part 1-8: Joints*
- *EN 1999-1-1-2008 Design of aluminum structures – part 1-1: General structural rules*
- *ISO 16281:2008 Rolling bearings - Methods for calculating the modified reference rating life for universally loaded bearings*
- *ISO 16281:2008 / Cor. 1:2009 Rolling bearings - Methods for calculating the modified reference rating life for universally loaded bearings*
- *ISO 281:2007 Rolling bearings - Dynamic load ratings and rating life - Life modification factor aDIN and calculation of the modified rating life*
- *ISO 76:2006 Rolling bearings - Static load ratings*
- *ISO 898-1:2013, Mechanical properties of fasteners made of carbon steel and alloy steel -- Part 1: Bolts, screws and studs with specified property classes -- Coarse thread and fine pitch thread*

- *VDI 2230 Blatt 1, 2016, Systematic calculation of highly stressed bolted joints - Joints with one cylindrical bolt*
- *ISO 4413:2011 Hydraulic fluid power -- General rules and safety requirements for systems and their components*
- *DIN 51524-3_1990 Pressure fluids - Hydraulic oils - Part 3: HVLP hydraulic oils, Minimum requirements*
- *ISO 16889:2008 Hydraulic fluid power -- Filters -- Multi-pass method for evaluating filtration performance of a filter element*
- *UNE-EN 14359:2008+A1:2011: Gas-loaded accumulators for fluid power applications.*
- *PED 2014/68/EU Pressure Equipment Directive*
- *DNV-DS-J102:2010 Design and Manufacture of Wind Turbine Blades, Offshore and Onshore Wind Turbines*
- *DNVGL-ST-0126:2016 Support structures for wind turbines*
- *DIBt - Richtlinie für Windenergieanlagen - Oktober 2012, korrigierte Fassung März 2015*
- *DIBt – Richtlinie für Windenergieanlagen:2012, Einwirkungen und Standsicherheitsnachweise für Turm und Gründung.*

GEARBOX

- *IEC 61400-4:2012 Wind turbines -- Part 4: Design requirements for wind turbine gearboxes*

ELECTRICAL

- *IEC 61400-21:2008 Wind turbine generator systems - Part 21: Measurement and assessment of power quality characteristics of grid connected wind turbines*
- *IEC 61400-24 Ed. 1.0 (2010) Wind turbines - Part 24: Lightning protection.*
- *IEC 60076-16:2018 – Power transformers - Part 16: Transformers for wind turbine applications*
- *EN 60204-1:2006 (+correct 2010) Safety of machinery - Electrical equipment of machines - Part 1: General requirements*
- *EN 61000-6-2:2005 Electromagnetic compatibility (EMC) - Part 6-2: Generic standards – Immunity for industrial environments.*
- *EN 61000-6-4:2007 Electromagnetic compatibility (EMC) - Part 6-4: Generic standards - Emission standard for industrial environments.*
- *EN 61439-1:2014 Low-voltage switchgear and control gear assemblies. General rules*
- *EN 61439-2:2011 Low-voltage switchgear and control gear assemblies. Power switchgear and control gear assemblies*
- *Low Voltage Directive 2014/35/EU*
- *EMC Directive 2014/30/EU*

QUALITY

- *ISO 9001:2015 Quality management systems – Requirements*

PERSONAL SAFETY

- 2006/42/EC Machinery Directive
- EN 50308:2004, Wind turbines – Protective measures – Requirements for design, operation and maintenance.
- OSHA 2005 Requirements for clearances at doorways, hatches, and caged.
 - OSHA's Subpart D Walking-Working Surfaces Section 1910.27v
- ISO12100:2011 Safety of machinery – General principles for design – Risk assessment and risk reduction
- ISO 13849-1:2015 – Safety of machinery – Safety-related parts of control systems – Part 1: General principles for design
- ISO 13849-2:2013 - Safety of machinery – Safety-related parts of control systems – Part 2: Validation

CORROSION

- *ISO 12944-1:2017, Paints and varnishes - Corrosion protection of steel structures by protective paint systems – Part 1: General introduction (class C3 to C4)*

Other Performance Features

Siemens Gamesa Renewable Energy (SGRE) offers the following optional performance features for the SG 6.0-170 that can optimize your wind farm by boosting performance, enhancing environmental agility, supporting compliance with legal regulation, and supporting grid stability.

High Wind Derated operational mode

In the case of SG 6.0-170 high wind derated mode, it is enabled as it can be observed on the different power curves included in this document. The power production is limited once wind speed exceeds a threshold value defined by design, until cut-out wind speed is reached and the wind turbine stops producing power. This functionality extends the range of operation in high wind conditions limiting turbine loads dependent of maximum operational wind speed, providing more predictable energy output, minimizing production losses, and improving grid stability by reducing the risk of simultaneous power cut outs.

High Temperature Ride Through (also known as Temperature De-Rating)

Ventilation and cooling systems are designed to allow the WTG operation at rated power up to a certain external nominal temperature and a certain altitude. For sites located beyond 1000m above the sea level, the air density reduction affects the turbine components ventilation capacity, reducing the maximum operational temperature at rated power. However, this maximum ambient temperature can be extended by reducing the delivered power.

Considering the individual components requirements in temperatures at different altitude levels, and their dissipated heat at different power limits, several curves power-temperature will be generated. These curves will define the envelopes inside which SG 6.0-170 could operate assuring the integrity of all components.

High temperature kit could be included in case operating range needs to be extended.

The control system, considering the defined turbine type and altitude above sea level, will dynamically adjust the maximum allowed power as a function of the ambient temperature.



Ice Detection System

Ice Detection System (Default)

The default ice detection method is an integrated part of the Siemens Gamesa Renewable Energy (SGRE) wind turbine controller. It is a software solution that can be used to detect ice on the turbine blades by comparing actual performance data to the turbine nominal power curve. The actual performance is based on 10 minutes average data. If the actual performance is below the low power ice detection power curve, then under certain conditions it is reasonable to assume that the low power production is caused by ice build-up on the blades. This method of ice detection is only available when the turbine is operating.

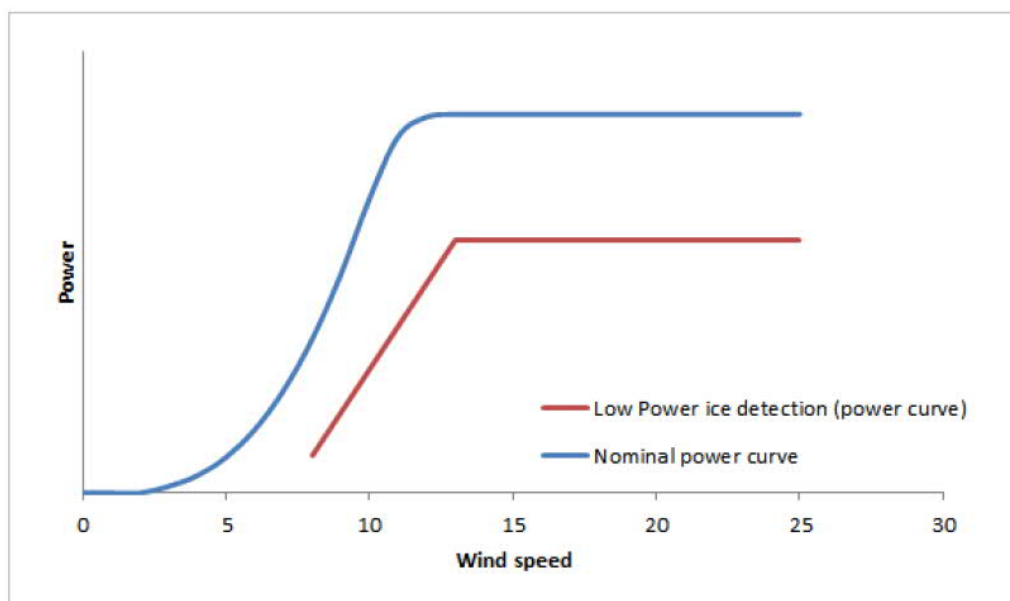

Figure 1: Illustrative comparison of the low power ice detection power curve and the nominal power curve.

Ice Detection Sensors

Nacelle Based Ice Detection Sensor (Optional)

The nacelle ice detection sensor is an optional system intended for installation on wind turbines located in areas where ice can build up on the turbine. The purpose of the ice detector system is to provide the turbine controller information about potential risk for ice on the turbine. The ice detection system can detect in-cloud icing as well as freezing rain.

Depending on requirements, when ice is detected an ice alarm can initiate a turbine stop. This may be followed by a de-icing sequence (if de-icing is installed), or yaw to a predefined position until it is deemed safe to restart.

Enhanced Ice Detection Function (Optional)

An enhanced ice detection function is an optional safety system, which is primarily used on sites exposed to icy conditions. The system will provide information to the wind turbine controller about the potential risk of ice on the rotor blades.

The algorithm is based on an ice probability calculation evaluating performance, temperature, humidity (additional sensor installed), wind speed and a nacelle-mounted ice sensor (additional sensor installed). Depending on the site requirements the alarm may cause a turbine stop, a visual and/or acoustic warning on site (optional) and/or – if installed – the rotor blade de-icing system is activated. The alarm is active until the site conditions are back to a regular state.

Certification

The systems can come with a valid certification from accredited institutes.

System Architecture

The system consists of the following parts:

- Sensors including control and evaluation units (Optional)
- Interface to the SGRE wind turbine controller
- Alarm communication to the SGRE SCADA system
- Installation and maintenance according to the valid contract clauses

Integration in SCADA System

SCADA interface for Ice Detection system enables the following:

- Set predefined ice conditions using ice parameters
- Enable or disable automatic stop of turbines
- Enable or disable automatic restart of turbines
- Group turbines for auto stop and auto restart. The SCADA system recommends to group ice sensor installed turbines along with turbines on which ice sensors are not installed.

Default ice parameters are set in SCADA interface. Depending on requirements, default ice parameters can be modified to configure new ice conditions through the SCADA interface.

- **Ice Restart Delay:** Turbines which are stopped due to ice is restarted only if ice is not reported during the ice restart delay in seconds configured by the user.
- **Ice Stop Delay:** Turbines are stopped due to ice only if ice is detected on turbines for more than the ice stop delay in seconds configured by the user.
- **Ambient Temperature Duration:** Duration in seconds when Ice Ambient Temperature configured by the user remains or exceeds, to restart the turbines which are stopped due to ice.
- **Ambient Temperature Threshold:** The minimum temperature in Celsius configured by the user which sets a condition to restart turbines stopped due to ice formation on blades. The ambient temperature must exceed the Ice Ambient temperature configured by the user for duration in seconds as specified in Ambient Temperature duration. Setting of ice ambient temperature and Ambient temperature duration prevents turbines from rapidly switching between ice start and ice stop operations.
- **Activation Time:** The Ice Control Start time and Ice Control End time configured by the user in the interface defines the activation time. Turbines are stopped due to ice when current time falls within the time range configured in Ice Control Start Time and Ice Control End time. When the current time falls outside the range specified in Ice Control Start Time and Ice Control End time, the turbines are restarted. SCADA system recommends setting time ranges such that turbines can be stopped during the day and started at night.

Ice build-up on the turbine can possibly cause damage to objects and people in the vicinity. It is the sole responsibility of the owner of the turbine(s) to ensure that the public is protected from ice being thrown from the turbine(s). The Owner must always ensure that the operation of the turbine(s) comply with any restriction applicable to the turbine(s), irrespective of whether such restrictions follows from permits, legislation or otherwise. Siemens Gamesa Renewable Energy accepts no responsibility for any violation of requirements.