



REGIONE SICILIANA
Città Metropolitana di Palermo
COMUNI DI GANGI E BOMPIETRO



IMPIANTO AGRO-FOTOVOLTAICO “SERRA DEL VENTO”

Progetto per la realizzazione di un impianto agro-fotovoltaico denominato “Serra del Vento” per una potenza complessiva di immissione in rete pari a 20,0 MW e opere connesse da realizzarsi nei comuni di Gangi e Bompietro.

Progetto di cui all'art. 17/1/a – allegato 1/bis – D.L. 31/05/2021 n. 77, come modificato dalla legge di conversione 29/07/2021 n. 108 “opere, impianti e infrastrutture necessarie al raggiungimento degli obiettivi fissati dal PNIEC-PNRR”.

COMMITTENTE



AM ENERGIE RINNOVABILI srl
Via di Belgioso 4 – 90015 Cefalù | Tel. 0921 421046
Email: info@amerenergieinnovabili.com | PEC: energieinnovabili@pec.it
P. IVA 05830120829 | Capitale sociale: € 100.000,00 i.v

PROGETTAZIONE E GRUPPO DI LAVORO



EMILY MIDDLETON & PARTNERS srl
Via Saverio Scrofani 16 – 90143 Palermo
Email: giuseppinaleone@emilymiddleton.it
PEC: emilymiddleton@pec.it

Arch. Giuseppina Leone	Progetto ambientale	arch.gleone@gmail.com
Ing. Vincenzo Butticè	Progetto geotecnico	ing.vincenzobuttice@libero.it
Arch. Elena Belvedere	Progetto paesaggistico	belvederelena@gmail.com
Ing. Giovanni Barlotti	Progetto elettrico	g.barlotti@yahoo.it
Dott. Giuseppe D'Angelo	Progetto pedoagronomico	gdangelo84@gmail.com
Prof. Dott. Giuseppe Barbera	Consulenza paesaggi dell'energia	giusepbarbera@gmail.com
Dott. Giovanni Spallino	Consulenza archeologica	giovannispallino@gmail.com

Handwritten signature

IDENTIFICATIVO ELABORATO RS06REL0004A0

DESCRIZIONE ELABORATO RELAZIONE ELETTRICA

REV	DATA	OGGETTO DELLA REVISIONE	ELABORAZIONE	VERIFICA	APPROVAZIONE
00	Marzo 2022	Emissione progetto definitivo	Ing. G. Barlotti	Arch. G. Leone	AM energie rinnovabili srl

	Tipo: Documentazione di Progetto	
	Titolo: Relazione elettrica	
	Rev. 0 – marzo 2022	Pag. 2

Sommario

PREMESSA	3
1. DEFINIZIONE DELLA CONNESSIONE (VEDI TICA)	4
1.1 Schema d’inserimento	4
2. LAYOUT DI IMPIANTO PV AM ENERGIE RINNOVABILI	5
2.1. Caratteristiche della connessione – schema	7
3. DESCRIZIONE IMPIANTO	8
3.1. Architettura di campo PV	8
3.2. Tipologia di cavi MT da utilizzare in posa interrata	14
3.3 Il Controllo	16
3.4. Opere civili propedeutiche alle opere elettriche	18
3.4.1. Opere civili di fondazione	18
3.4.2. Opere per la posa dei cavidotti	18
3.5. Cabina step-up il “trasformatore in resina”	18
4. FASCICOLO TECNICO ELEMENTI	22

Comuni:	Gangi – Bompietro	Provincia:	Palermo
Denominazione:	Serra del Vento	Potenza:	20,0 MW

	Tipo: Documentazione di Progetto	
	Titolo: Relazione elettrica	
	Rev. 0 – marzo 2022	Pag. 3

PREMESSA

La seguente relazione descrive secondo le forme canoniche il contenuto dell'attività progettuale riguardante l'iniziativa imprenditoriale di AM Energie Rinnovabili S.r.l., con sede in Via Di Belgioioso, 4 - 90015 Cefalù (PA), per la realizzazione dell'impianto fotovoltaico costituito da un generatore di potenza massima in immissione lato AC di 20046 kW del tipo ad inseguitori mono assiali N-S, con esposizione moduli E-O e convertitori decentralizzati di stringa, di seguito descritto. Il PCC (punto di scambio energia) con il TSO è già definito presso la sezione AT 150 kV della stazione di utenza fig. 1 a servizio del parco eolico "Serra del Vento" in esercizio in capo alla medesima società.



Fig. 01 - stazione di utenza AT/MT

Comuni:	Gangi – Bompietro	Provincia:	Palermo
Denominazione:	Serra del Vento	Potenza:	20,0 MW

	Tipo: Documentazione di Progetto	
	Titolo: Relazione elettrica	
	Rev. 0 – marzo 2022	Pag. 4

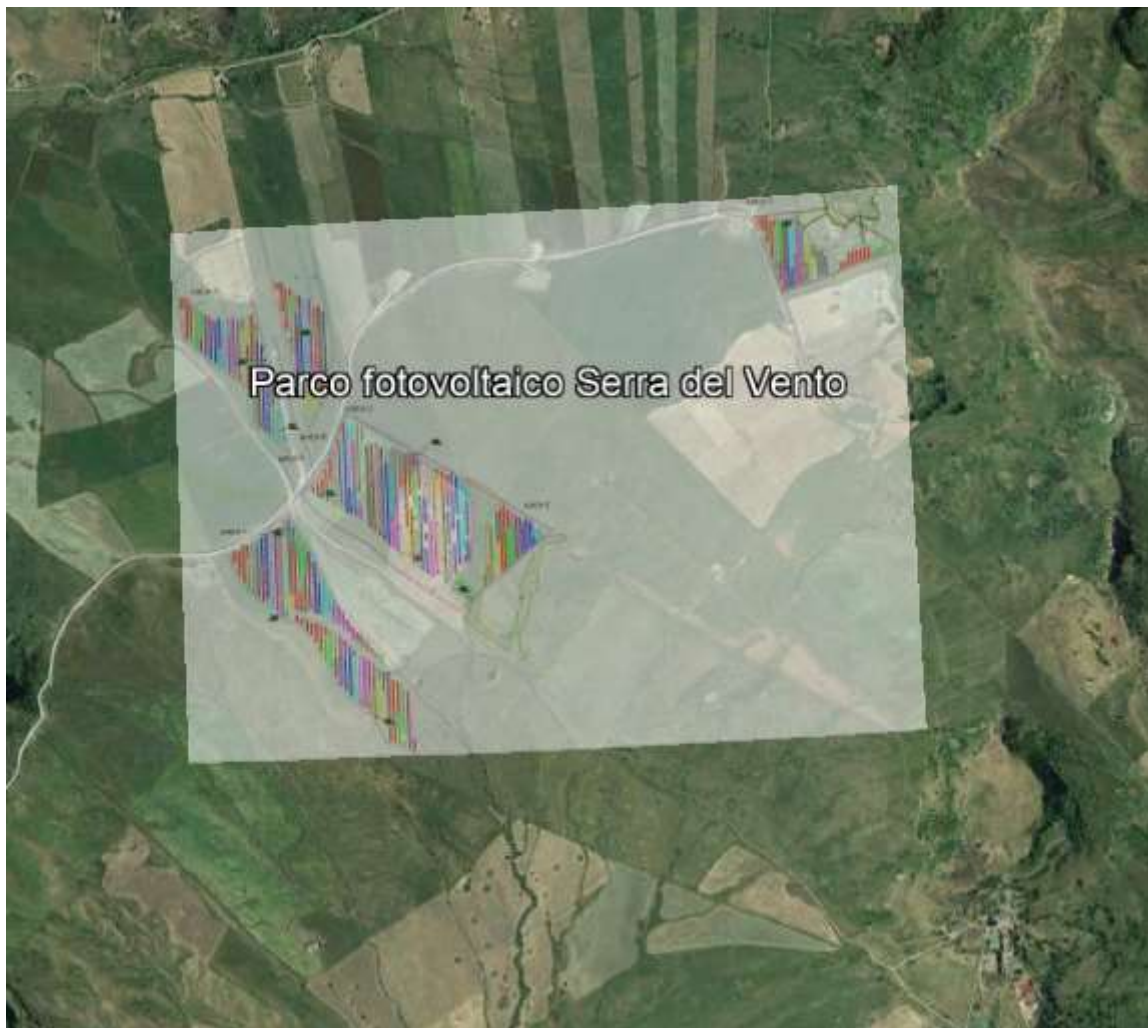



Fig. 02- area impianto fotovoltaico su ortofoto

1. DEFINIZIONE DELLA CONNESSIONE (VEDI TICA)

1.1 Schema d'inserimento

- *inserimento in antenna su stazione utente AT/MT esistente.*

Comuni:	Gangi – Bompietro	Provincia:	Palermo
Denominazione:	Serra del Vento	Potenza:	20,0 MW

	Tipo: Documentazione di Progetto	
	Titolo: Relazione elettrica	
	Rev. 0 – marzo 2022	Pag. 5

2. LAYOUT DI IMPIANTO PV AM ENERGIE RINNOVABILI

Nella tabella, di seguito, pubblicata sono riportati i componenti che costituiscono il generatore fotovoltaico nella sua costituzione completa. Il generatore utilizza 33.912,0 moduli di manifattura Canadian Solar, il modello individuato appartiene alla famiglia innovativa dei bifacciali identificato con sigla “BiHiKu7BIFACIAL MONO PERC”, potenza nominale 655 W. La suddivisione dei moduli e la loro distribuzione in campo tiene conto del tipo di impianto che si intende realizzare. Nel caso in esame un impianto ad inseguitori mono assiali N-S, con esposizione moduli E-O e convertitori decentralizzati di stringa. Il convertitore DC/AC (di seguito inverter) è il modello a catalogo della Canadian Solar di nuova generazione adeguato ai moduli bifacciali, identificato con sigla “CSI-255K-T800GL02-E” Inverter di stringa multi-MPPT per sistema a 1500 Vcc. La scelta di questo inverter consente di collegare ai quattordici ingressi MPPT di cui è dotato, stringhe per un numero massimo di quattordici. Lo schema unifilare generale Tav. 05 riporta in forma grafica l’impiego dei moduli e dei convertitori. Le stringhe sono state organizzate in funzione dei parametri elettrici del modulo e dei limiti imposti agli ingressi dell’inverter dal produttore. Ogni stringa è formata dalla serie di 24 moduli, cablate su un singolo inseguitore, (rif. Tav. 02). Le Tavv. 02, 03 e 04 rappresentano la sintesi grafica a cui fare riferimento per una visione d’insieme di quanto descritto.

Comuni:	Gangi – Bompietro	Provincia:	Palermo
Denominazione:	Serra del Vento	Potenza:	20,0 MW

	Tipo: Documentazione di Progetto	
	Titolo: Relazione elettrica	
	Rev. 0 – marzo 2022	Pag. 6

<i>Impianto fotovoltaico "Serra del Vento"</i>		
Solar panel definition	PV Module Model	BiHiKu7BIFACIAL MONO PERC
	PV Module Type	Bifacial
	Capacity solar panel (Wp)	655,0
Inverter definition	Inverter Model	CSI-255K-T800GL02-E
	Inverter Type	String-inverter
	Inverter Rating (kW) @40°C*cos(φ)=0,95	238,460
DC side definition	# Panels	33.912
	Project Size (DC), kW	22.212,36
AC side definition	Inverter QTY	104,0
	Project Size (AC @40°C*cos(φ)=0,95), kW	20.046,65
Oversizing	DC/AC Ratio @40°C*cos(φ)=0,95	1,10
Electrical configuration	String size (# Panels in series)	24
	# Strings	1417
	Strings per Inverter	14
Mechanical configuration	Fixed/Tracking	Tracking 1Axis
	Table Configuration	2n12 portrait
	Strings per table	1,0
	Backtracking (On/Off)	On
	Pitch	7,0

Comuni:	Gangi – Bompietro	Provincia:	Palermo
Denominazione:	Serra del Vento	Potenza:	20,0 MW

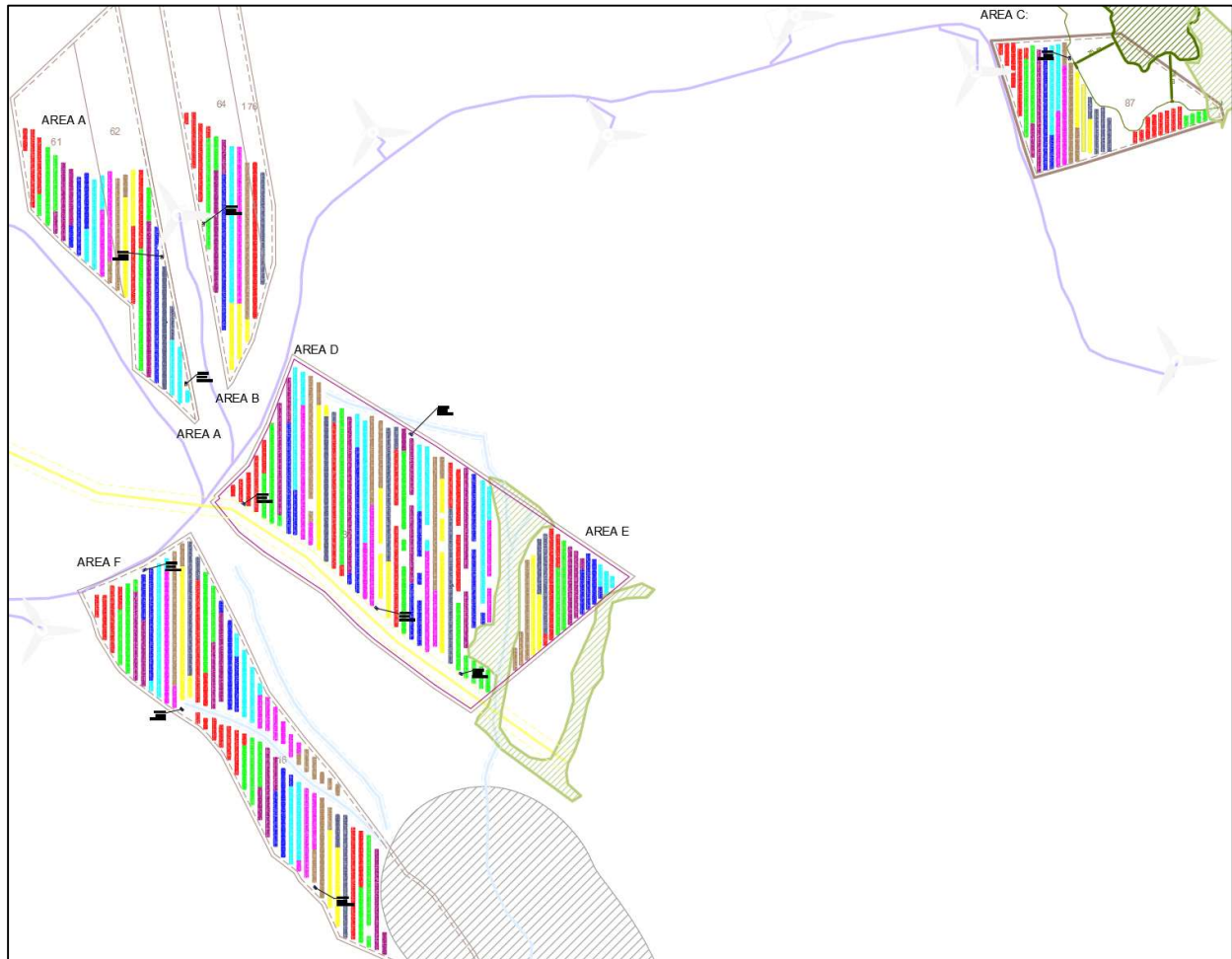



Fig. 03 - Layout impianto su rilievo topografico

2.1. Caratteristiche della connessione – schema

Per le caratteristiche della connessione e del PCC si rimanda alla documentazione di progetto definitivo per la connessione di impianto PV.

Comuni:	Gangi – Bompietro	Provincia:	Palermo
Denominazione:	Serra del Vento	Potenza:	20,0 MW

	Tipo: Documentazione di Progetto
	Titolo: Relazione elettrica
	Rev. 0 – marzo 2022

Pag. 8

3. DESCRIZIONE IMPIANTO

3.1. Architettura di campo PV

Il campo fotovoltaico ad inseguimento mono assiale sarà esposto, con un orientamento azimutale a 90° rispetto al sud ed avrà un'inclinazione rispetto all'orizzontale variabile con angolo da 0 a $\pm 60^\circ$. Il sistema di supporto moduli PV, circuiteria e convertitori, fissato al terreno tramite infissione di pali, è a elementi metallici in acciaio ad alta resistenza galvanicamente protetti, componibili in cantiere, formano un'ossatura orizzontale, esso a montanti e traversi rappresenta il caposaldo di tutti i sistemi di facciata continua con regolazione del corretto angolo di esposizione ai raggi solari. I 24 moduli che compongono la stringa unitaria saranno installati su singola tavola (array) doppia fila da 12 (2x12 portrait), come da figura 4.

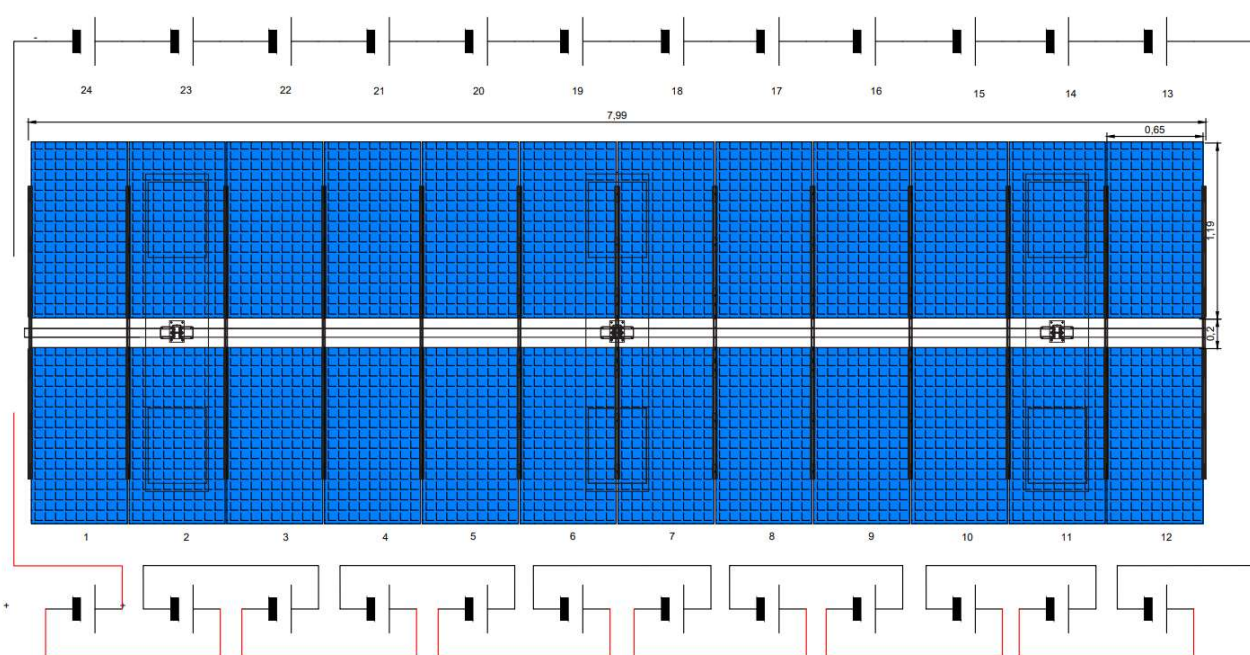



Fig. 04 - stringa in doppia fila 2x12 portrait

Di seguito si riporta sezione del modulo tracker che permetterà l'inseguimento Est-Ovest.

Comuni:	Gangi – Bompietro	Provincia:	Palermo
Denominazione:	Serra del Vento	Potenza:	20,0 MW

	Tipo:	Documentazione di Progetto	
	Titolo:	Relazione elettrica	
	Rev. 0 – marzo 2022		Pag. 9

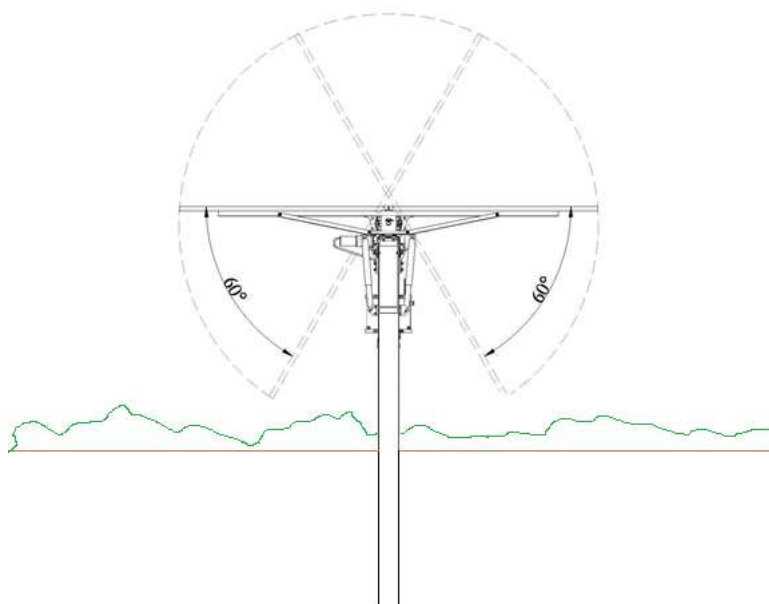



Fig 05 - esempio di inseguitore "Tracker"

L'energia elettrica, che i 104 inverters convertono da DC a AC, viene raccolta in 11 cabine step-up di trasformazione, identificate nello schema unifilare allegato alla presente, dalle lettere dell'alfabeto "A...M". In particolare, lungo il perimetro delle sei macroaree mostrate in fig.1 (A ...F) sono dislocate le 11 cabine la cui potenza di trasformazione è normalizzata nove su taglia 2,5 MVA, una su 2,0 MVA e una 1,0 MVA. Le cabine di trasformazione sono raccolte con tecnica entra-esce su due linee MT da 33 kV distinte che raccolgono l'energia prodotto da due sottocampi costituiti dalle macroaree seguenti:

1. C, D e E (cabb. A-E-F-G-H);
2. A, B e F (cabb. B-C-D-I-L-M).

Le due linee uscenti, la prima dalla cabina F la seconda dalla cabina I, si attestano alla cabina di smistamento dove arriva tramite tecnica entra esce anche la produzione dei due sottocampi eolici che costituiscono l'impianto eolico denominato "Serra del Vento". Dalla cabina di smistamento l'energia prodotta dall'impianto eolico esistente e dal futuro impianto fotovoltaico

Comuni:	Gangi – Bompietro	Provincia:	Palermo
Denominazione:	Serra del Vento	Potenza:	20,0 MW

	Tipo: Documentazione di Progetto	
	Titolo: Relazione elettrica	
	Rev. 0 – marzo 2022	Pag. 10

viene con doppia terna di cavi interrati MT 33 kV in alluminio a elica visibile, esistenti già in opera, raggiunge l'opera di utenza per la connessione, la stazione Utenza AT/MT, il punto di scambio è posto sullo stallo linea in AT.

Cabina di smistamento								
ID cabina step-up	Transform power step-up (kVA)	Numero di inverter/cabina Id	Numero moduli (655 W)	Inverters Power (kVA dc)	DC/AC Ratio @40°C* cos(φ)=0,95	Inverter Power (kW ac)		
A	2500	1...11	3432	2247,96				
B	2500	12...21	3216	2106,48				
C	2500	26...35	3360	2200,8				
D	1000	22...25	1272	833,16				
E	2500	46...55	3360	2200,8				
F	2500	36...45	3360	2200,8				
G	2500	56...65	3360	2200,8				
H	2500	66...76	3336	2185,08				
I	2500	77...87	3696	2420,88				
L	2500	88...97	3216	2106,48				
M	2000	98...104	2304	1509,12				
	25500	104	33912	22212,36			1.10	20.046,65

Tabella 2 riassuntiva accoppiamenti cabine step up BT/MT - Convertitori DC/AC

Le cabine step up hanno la sola funzione di elevare il livello di tensione da BT a 800 V_{ac} a MT 33 kV.

La struttura "container" in fase esecutiva può essere suddivisa in 2 o 3 vani per il trasformatore, la parte delle apparecchiature MT e quella per le apparecchiature BT. Le dimensioni esterne e dettagli costruttivi il riferimento è IL FASCICOLO TECNICO.

Dal punto di vista costruttivo, il prefabbricato, poggiata su una platea in c.a. semi interrata a sua volta poggiata su una superficie in magrone livellante in calcestruzzo magro.

Comuni:	Gangi – Bompietro	Provincia:	Palermo
Denominazione:	Serra del Vento	Potenza:	20,0 MW

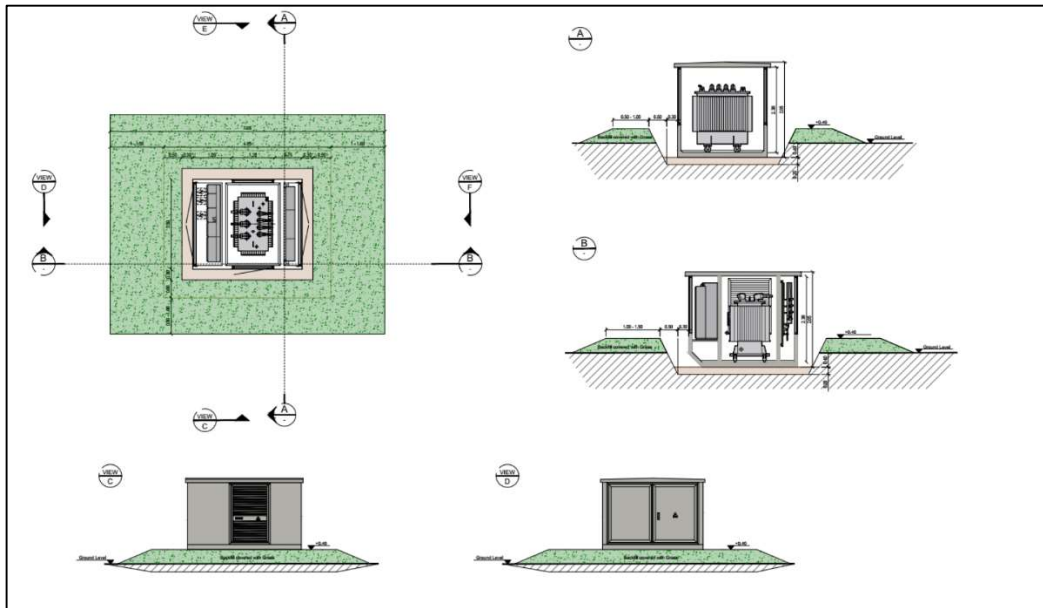



Fig. 06

Le apparecchiature elettriche ospitate in cabina sono:

- Power Center in AC su cui si attestano le linee trifase con neutro in BT in uscita dagli inverter. Il quadro avrà una tensione nominale di esercizio di 800 V_{ac} e corrente nominale di impiego pari a 2500 A indipendentemente dalla potenza del trasformatore; ciò al fine di standardizzare il più possibile le apparecchiature di BT utilizzate. Il quadro sarà rispondente alla norma EN 61439-1 (CEI 17-113) " *Apparecchiature assiemate di protezione e di manovra per bassa tensione (quadri BT) - Parte 1: Regole generali* " e la EN 61439-2 (CEI 17-114), " *Apparecchiature assiemate di protezione e di manovra per bassa tensione (quadri BT) - Parte 2: Quadri di potenza* ".
- Trasformatore BT/MT con tensione nominale pari a 33 kV con isolamento in resina, con potenze variabili da 1000 kVA a 2500 kVA a seconda del numero di inverter afferenti alla cabina così come indicato nelle tavole grafiche di progetto. I

Comuni:	Gangi – Bompietro	Provincia:	Palermo
Denominazione:	Serra del Vento	Potenza:	20,0 MW

	Tipo: Documentazione di Progetto	
	Titolo: Relazione elettrica	
	Rev. 0 – marzo 2022	Pag. 12

trasformatori saranno rispondenti alla norma EN 50588- 1

- Quadri di media tensione, costituiti da moduli prefabbricati standardizzati con tensione nominale di 36 kV, corrente nominale di 630A e corrente ammissibile di breve durata di 31.5 kA. Questi moduli saranno rispondenti alle norme di prodotto ed in particolare alla norma IEC/EN 62271-200/;
- Quadro servizi ausiliari in BT 0,4 kV, rispondenti alla norma EN 61439-1;
- Sistema di dissipazione del calore tramite ventilatori;
- Impianto elettrico completo (cavi di alimentazione, illuminazione, prese elettriche, messa a terra della rete, etc);
- Dotazioni di sicurezza;
- Trasformatore di isolamento BT/BT a secco per alimentazione quadro servizi ausiliari BT-AUX;
- UPS per i servizi ausiliari e relative batterie;
- Sistema centralizzato di comunicazione con interfacce RS485/USB/ETHERNET;
- Unita RTU per connessione a SCADA e Plant controller.

Tali sistemi elettrici saranno dotati di interfacce di connessione con il sistema di comunicazione e collegati al sistema di supervisione.

Al fine di garantire la continuità di servizio per i circuiti ausiliari delle apparecchiature presenti in cabina, è previsto l'installazione di un gruppo statico di continuità indicativamente da 5 kVA; con riserva di carica per la specifica gestione del riarmo delle bobine di minima tensione.

Comuni:	Gangi – Bompietro	Provincia:	Palermo
Denominazione:	Serra del Vento	Potenza:	20,0 MW

	Tipo: Documentazione di Progetto
	Titolo: Relazione elettrica
	Rev. 0 – marzo 2022 Pag. 13

La cabina di smistamento/raccolta sarà realizzata in cls di tipologia standard, dimensioni come da tavola di riferimento. In fase esecutiva, la struttura potrà presentare una suddivisione diversa da quanto rappresentato al momento per future esigenze tecniche volendo creare locali destinati ad ospitare: gruppo elettrogeno; TRSA; quadri BT in AC e DC; apparecchiature di TLC. Più in particolare:

Vano Contatori (QME);

Scomparto locale quadri BT;

Locale Gruppo Elettrogeno;

Locale TRSA;

Locale ufficio SCADA.

Rimane invariata l'area destinata ad ospitare unicamente il quadro di Media Tensione, costituito da moduli prefabbricati standardizzati con tensione nominale di 36 kV, corrente nominale di 630A e corrente ammissibile di breve durata di 31.5 kA. Questi moduli saranno rispondenti alle norme di prodotto ed in particolare alla norma CEI EN 62271-200 prima descritto.

La cabina smistamento, tipicamente in posizione di partenza delle linee in cavo MT verso la Stazione Utente, ospita un quadro di Media Tensione, con interruttori in vuoto in grado di interrompere le correnti di guasto interne ed esterne al campo fotovoltaico, che la rende indipendente dal punto di vista dell'estinzione del guasto. Questo consente di implementare strategie di automazione che discriminano solo le linee MT interessate dal guasto lasciando le linee integre in servizio. I moduli MT con interruttore diventano moduli di protezione con funzioni di selettività cronometrica, regolazione della tensione e rilevazione misure. L'adozione di dispositivi intelligenti (IED) in grado di dialogare tra loro con protocolli evoluti quali ad

Comuni: Gangi – Bompietro	Provincia: Palermo
Denominazione: Serra del Vento	Potenza: 20,0 MW

	Tipo: Documentazione di Progetto	
	Titolo: Relazione elettrica	
	Rev. 0 – marzo 2022	Pag. 14

esempio IEC 61850, consentirà in caso di guasto lo scambio di segnali di blocco agli IED per un certo tempo l'intervento degli interruttori che non devono intervenire, mentre l'IED che non ha ricevuto il segnale di blocco comanda l'apertura del proprio interruttore al fine di estinguere il guasto. Pertanto, la cabina smistamento gioca un ruolo fondamentale nello scambio di segnali tra le cabine di trasformazione e la stazione Utente AT/MT, anch'essa dotata di interruttori DG e IED.

Dal punto di vista costruttivo, i due locali saranno realizzati con struttura portante in cls prefabbricato, poggiata su una platea in c.a. semi interrata a sua volta poggiata su una superficie in magrone livellante in calcestruzzo magro.

3.2. Tipologia di cavi MT da utilizzare in posa interrata

<i>Tipo di cavo</i>	<i>ad elica visibile</i>
<i>Materiale del conduttore</i>	<i>Alluminio</i>
<i>Materiale isolante</i>	<i>EPR/XLPE</i>
<i>Schermo metallico</i>	<i>Rame/alluminio</i>
<i>Guaina esterna</i>	<i>PVC/PE</i>
<i>Tensione nominale (U₀/U/U_m)</i>	<i>18/30/36 kV</i>
<i>Frequenza nominale</i>	<i>50 Hz</i>
<i>Sezioni utilizzate</i>	<i>95 -150 - 500mm²</i>

Tabella 3 riassuntiva tipologia cavi impiegati in MT

L'architettura delle infrastrutture energetiche descritta può essere schematizzata come di seguito:

- *Cavi MT a 33 kV interrati a elica visibile in alluminio interni al campo fotovoltaico per la connessione in entra -esce cabine di trasformazione e cabina di impianto;*
- *Quadri MT a 33 kV per la gestione dei flussi di energia e relativa misura e monitoraggio,*

Comuni:	Gangi – Bompietro	Provincia:	Palermo
Denominazione:	Serra del Vento	Potenza:	20,0 MW

	Tipo: Documentazione di Progetto	
	Titolo: Relazione elettrica	
	Rev. 0 – marzo 2022	Pag. 15

posti nelle cabine di campo PV, smistamento e nella struttura edile MT di stazione utenza;

- *Impianto di Utenza per la connessione alla rete del TSO, costituito dalla stazione utente.*

La tipologia e le sezioni dei cavi elettrici sono determinate sulla base del tipo di servizio e del tipo di posa previsti. La Tav.05 riassume tutte le tipologie di sezioni previste per l'insieme delle trincee che rappresentano le infrastrutture energetiche e di segnale necessarie al corretto funzionamento del campo fotovoltaico.

Nello specifico l'impianto comprenderà le seguenti opere (rif. Tav. 5):

- *Cabina di smistamento raccolta interna al campo fotovoltaico in MT 33kV completa di quadri MT e BT e impianti ausiliari illuminazione, distribuzione F.M, illuminazione di sicurezza;*
- *Undici cabine step-up di trasformazione BT/MT 0.8/33 kV, una per ogni sezione di campo PV (vedi Tav. 3), complete di quadri in MT e BT, trasformazione locale BT/BT per servizi ausiliari;*
- *Realizzazione di tutte le condutture principali di distribuzione elettrica in uscita/entrata dai Quadri Generali ed alimentanti i vari quadri/utenze;*
- *Realizzazione dell'impianto di terra ed equipotenziale costituito da una corda di rame lungo il perimetro del campo e delle cabine, dotate di collettori di terra, e le connessioni dai conduttori di terra ai conduttori di protezione ed equipotenziali e da tutti i collegamenti PE ed equipotenziali;*
- *Realizzazione dell'impianto di videosorveglianza, antintrusione e illuminazione del perimetro di impianto;*
- *Realizzazione di un sistema di comunicazione tramite fibra ottica e/o rame per la*

Comuni:	Gangi – Bompietro	Provincia:	Palermo
Denominazione:	Serra del Vento	Potenza:	20,0 MW

	Tipo:	Documentazione di Progetto	
	Titolo:	Relazione elettrica	
	Rev. 0 – marzo 2022		Pag. 16

trasmissione dei dati di controllo e gestione dell'impianto fotovoltaico nonché dei segnali di videosorveglianza ed allarme. Tale sistema interconetterà le undici cabine step up, la cabina di smistamento e la videosorveglianza, l'antintrusione e la stazione utente AT/MT 150/33 kV presso il PCC di consegna.

3.3 Il Controllo

Per la gestione dell'impianto da remoto nella sua completezza è prevista l'installazione di sistemi SCADA (Supervisory Control and Data Acquisition), in grado di dialogare tra loro e il centro di controllo della società, il primo per il controllo del campo PV inteso come:

1. *Acquisizione misura dell'irraggiamento solare e della temperatura di lavoro dei moduli;*
2. *Valutazione delle prestazioni dell'impianto PV in fase di avvio;*
3. *Valutazioni delle prestazioni energetiche e delle grandezze elettriche.*

Il secondo già presente per il controllo, la gestione della stazione di utente e lo scambio energetico con il TSO. Entrambe i sistemi saranno posizionati in opportuni spazi interne alle due cabine nelle quali troveranno posto oltre ai quadri di energia, le apparecchiature di comando/protezione/telecontrollo servizi ausiliari e le batterie per UPS.

La contabilizzazione dell'energia al PCC scambiata con la rete AT del TSO verrà effettuata attraverso l'apparecchiatura di misura di proprietà di AM Energie Rinnovabili.

Dal punto di vista funzionale elettrico, oltre a funzioni base quali l'interruzione e la manovra/sezionamento del circuito elettrico e la comunicazione è possibile individuare quattro diversi livelli funzionali:

4. *Monitoraggio;*
5. *Controllo;*

Comuni:	Gangi – Bompietro	Provincia:	Palermo
Denominazione:	Serra del Vento	Potenza:	20,0 MW

	Tipo: Documentazione di Progetto	
	Titolo: Relazione elettrica	
	Rev. 0 – marzo 2022	Pag. 17

6. *Misura;*

7. *Protezione.*

Il monitoraggio, degli stati degli apparecchi di BT e MT, aumenta la disponibilità dei componenti delle cabine consentendo la riduzione dei tempi di guasto, utilizzando in modo efficiente la manodopera per mezzo delle acquisizioni in real time di:

- *stato dell'apparecchiatura di manovra di MT,*
- *indicazioni di guasto di MT;*
- *misure della rete MT o BT;*
- *monitoraggio delle condizioni della cabina elettrica.*

Il controllo minimizza i tempi di fuori servizio e aumenta l'efficienza dell'esercizio della infrastruttura energetica tramite:

- *la localizzazione e disconnessione remota del tronco guasto;*
- *il controllo remoto degli interruttori e interruttori di manovra sezionatori.*

La Misura per la gestione dei flussi energetici scambiati con il TSO e la misura della tensione al fine di garantire la stabilità e la minimizzazione delle perdite in fase di produzione intermittente del campo fotovoltaico.

Protezione e selettività garantiscono la massima disponibilità della rete di MT e anche di BT in caso di guasto con l'ausilio di protezioni avanzate dotate di protocollo IEC 61850.

Comuni:	Gangi – Bompietro	Provincia:	Palermo
Denominazione:	Serra del Vento	Potenza:	20,0 MW

	Tipo: Documentazione di Progetto	
	Titolo: Relazione elettrica	
	Rev. 0 – marzo 2022	Pag. 18

3.4. Opere civili propedeutiche alle opere elettriche

La realizzazione delle infrastrutture elettriche richiederà la realizzazione delle seguenti opere:

- *opere civili di fondazione;*
- *opere per la posa dei cavidotti.*

3.4.1. Opere civili di fondazione

Tali opere possono ascrivere all'interno del campo PV alla realizzazione del piano di posa delle cabine di trasformazione e di smistamento, alla recinzione.

3.4.2. Opere per la posa dei cavidotti

I cavi, come detto, internamente al campo sono in posa interrata, le opere riguardano lo scavo per la realizzazione delle trincee di posa. All'esterno del campo le opere fanno riferimento allo scavo in trincea per la posa del cavo di connessione campo PV cabina di smistamento.

3.5. Cabina step-up il “trasformatore in resina”

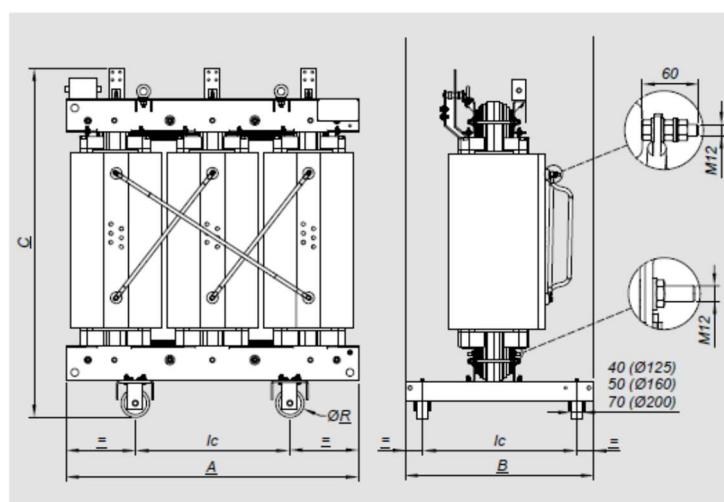



Fig. 07 - dimensioni trasformatori

Comuni:	Gangi – Bompietro	Provincia:	Palermo
Denominazione:	Serra del Vento	Potenza:	20,0 MW

	Tipo: Documentazione di Progetto
	Titolo: Relazione elettrica
	Rev. 0 – marzo 2022 Pag. 19

Rispondenza normativa:	IEC 60076-11 / EN 50558-1 /
Serie (Reg 548):	AoAk
Potenza (kVA):	1000–2500
Frequenza (Hz):	50
Regolazione, lato MT:	$\pm 2 \times 2.5\%$
Materiali: Alluminio per avvolgimenti primari e secondari (rame su richiesta)	
Gruppo vettoriale:	Dyn11
Classe termica del sistema isolante:	155 °C (F) / 155 °C (F)
Sovratemperatura:	100/100 K
Classe di impiego:	E2-C2-F1 Certificato IEC 60076-11
Tolleranze:	Secondo IEC /CEI
Tolleranze sulle perdite:	0%
Scariche parziali	< 5 pC
Tensioni primarie (kV):	30-36.
Classe di isolamento:	36 kV BIL 95 kV
Tensioni secondarie a vuoto (V):	800 (classe di isolamento 2.5 kV).

Condizioni di servizio

I trasformatori inglobati in resina, in esecuzione standard, sono adatti per installazioni all'interno, protetti dalla luce solare diretta, in ambienti puliti e asciutti.

La norma IEC 60076-11 identifica con un codice alfanumerico le classi ambientali, climatiche e di comportamento al fuoco dei trasformatori a secco. Grazie all'utilizzo di una resina epossidica di elevata qualità, tutti i trasformatori riducono al minimo l'impatto ambientale e sono conformi alle seguenti classi:

- *Classe ambientale E2;*
- *Classe climatica C2;*
- *Classe comportamento al fuoco F1.*

Comuni:	Gangi – Bompietro	Provincia:	Palermo
Denominazione:	Serra del Vento	Potenza:	20,0 MW

	Tipo: Documentazione di Progetto	
	Titolo: Relazione elettrica	
	Rev. 0 – marzo 2022	Pag. 20

Ciò significa che possono essere immagazzinati, trasportati e soprattutto utilizzati anche in condizioni ambientali estreme:

- *Temperatura ambiente minima: -25 °C;*
- *Temperatura ambiente massima: 40 °C;*
- *Umidità relativa massima: 93%.*

Inoltre, in configurazione standard, sono in grado di resistere a disturbi sismici con livello di accelerazione del suolo fino a 0,2g.

Equipaggiamento di serie

- *Terminali MT (n°3 pezzi)*
- *Barre terminali BT (n°4 pezzi)*
- *Regolazione lato MT (n°3 pezzi)*
- *Targhetta (n°1 pezzo)*
- *Golfari di sollevamento (n°4 pezzi)*
- *Morsetti per il collegamento a terra (n°2 pezzi)*
- *Ruote orientabili (n°4 pezzi)*
- *Materiali degli avvolgimenti: Alluminio (Al) su richiesta (Cu/Cu o Al/Cu o Cu/Al)*
- *Kit di scaricatori di sovratensione*
- *Termosonde Pt100 con cassetta di collegamento*
- *Centralina elettronica per il controllo termico, con ingressi per Pt100 e visualizzazione della temperatura*
- *Terminazioni MT per connessioni ad innesto (Elastimold).*

Accessori (su richiesta)

Comuni:	Gangi – Bompietro	Provincia:	Palermo
Denominazione:	Serra del Vento	Potenza:	20,0 MW

	Tipo: Documentazione di Progetto	
	Titolo: Relazione elettrica	
	Rev. 0 – marzo 2022	Pag. 21

- *Termistori PTC (in alternativa alle termosonde Pt100)*
- *Centralina elettronica per il controllo termico, con ingressi per PTC, senza visualizzazione della temperatura*
- *Sistemi di ventilazione forzata, per temporaneo aumento della potenza del trasformatore*
- *Centralina elettronica per sistema di ventilazione*
- *Box di protezione del trasformatore (grado di protezione IP23 e IP31)*
- *Supporti antivibranti.*

Comuni:	Gangi – Bompietro	Provincia:	Palermo
Denominazione:	Serra del Vento	Potenza:	20,0 MW

	Tipo: Documentazione di Progetto	
	Titolo: Relazione elettrica	
	Rev. 0 – marzo 2022	Pag. 22

4. FASCICOLO TECNICO ELEMENTI

Comuni:	Gangi – Bompietro	Provincia:	Palermo
Denominazione:	Serra del Vento	Potenza:	20,0 MW

Serra del Vento

AM Energie Rinnovabili S.r.l.

FASCICOLO TECNICO ELEMENTI

Modulo PV
Canadian Solar



BiHiKu7

BIFACIAL MONO PERC

635 W ~ 660 W





CS7N-635 | 640 | 645 | 650 | 655 | 660MB-AG





FRONT

BACK

MORE POWER

-  Module power up to 660 W
Module efficiency up to 21.2 %
-  Up to 8.9 % lower LCOE
Up to 4.6 % lower system cost
-  Comprehensive LID / LeTID mitigation technology, up to 50% lower degradation
-  Compatible with mainstream trackers, cost effective product for utility power plant
-  Better shading tolerance

MORE RELIABLE

-  40 °C lower hot spot temperature, greatly reduce module failure rate
-  Minimizes micro-crack impacts
-  Heavy snow load up to 5400 Pa, wind load up to 2400 Pa*

 **12 Years** Enhanced Product Warranty on Materials and Workmanship*

 **30 Years** Linear Power Performance Warranty*

1st year power degradation no more than 2%
Subsequent annual power degradation no more than 0.45%

*According to the applicable Canadian Solar Limited Warranty Statement.

MANAGEMENT SYSTEM CERTIFICATES*

ISO 9001:2015 / Quality management system
ISO 14001:2015 / Standards for environmental management system
ISO 45001: 2018 / International standards for occupational health & safety

PRODUCT CERTIFICATES*

IEC 61215 / IEC 61730 / INMETRO / UKCA
UL 61730 / IEC 61701 / IEC 62716 / IEC 60068-2-68
Take-e-way



* The specific certificates applicable to different module types and markets will vary, and therefore not all of the certifications listed herein will simultaneously apply to the products you order or use. Please contact your local Canadian Solar sales representative to confirm the specific certificates available for your Product and applicable in the regions in which the products will be used.

CSI Solar Co., Ltd. is committed to providing high quality solar products, solar system solutions and services to customers around the world. Canadian Solar was recognized as the No. 1 module supplier for quality and performance/price ratio in the IHS Module Customer Insight Survey, and is a leading PV project developer and manufacturer of solar modules, with over 55 GW deployed around the world since 2001.

* For detailed information, please refer to the Installation Manual.

ENGINEERING DRAWING (mm)

Rear View

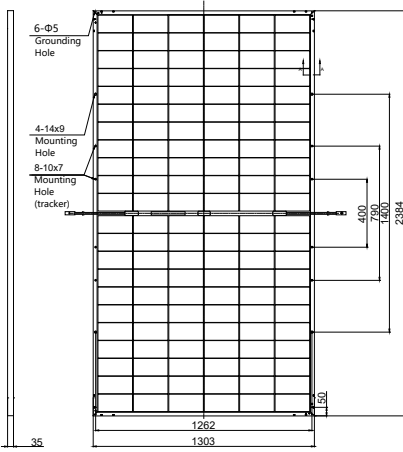

Frame Cross Section A-A

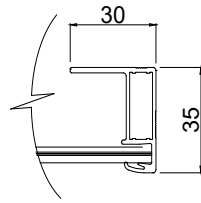

Mounting Hole

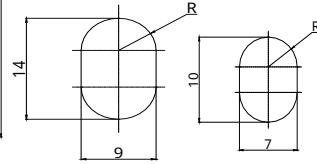

CS7N-650MB-AG / I-V CURVES

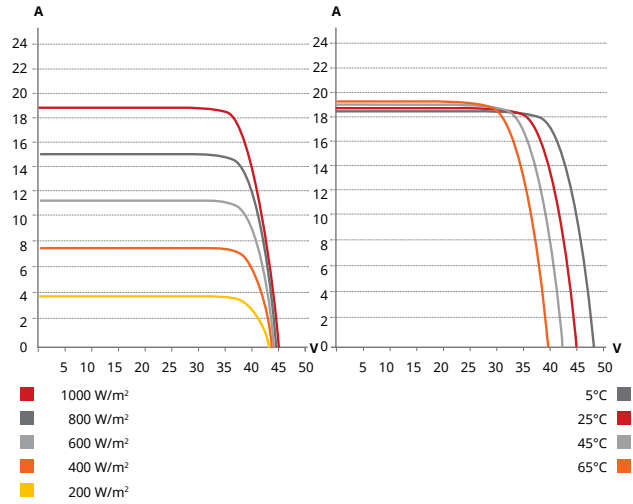

ELECTRICAL DATA | STC*

	Nominal Max. Power (Pmax)	Opt. Operating Voltage (Vmp)	Opt. Operating Current (Imp)	Open Circuit Voltage (Voc)	Short Circuit Current (Isc)	Module Efficiency
CS7N-635MB-AG	635 W	37.3 V	17.03 A	44.4 V	18.27 A	20.4%
Bifacial Gain**	5%	667 W	37.3 V	17.89 A	44.4 V	21.5%
	10%	699 W	37.3 V	18.74 A	44.4 V	22.5%
	20%	762 W	37.3 V	20.44 A	44.4 V	24.5%
CS7N-640MB-AG	640 W	37.5 V	17.07 A	44.6 V	18.31 A	20.6%
Bifacial Gain**	5%	672 W	37.5 V	17.92 A	44.6 V	21.6%
	10%	704 W	37.5 V	18.78 A	44.6 V	22.7%
	20%	768 W	37.5 V	20.48 A	44.6 V	24.7%
CS7N-645MB-AG	645 W	37.7 V	17.11 A	44.8 V	18.35 A	20.8%
Bifacial Gain**	5%	677 W	37.7 V	17.97 A	44.8 V	21.8%
	10%	710 W	37.7 V	18.84 A	44.8 V	22.9%
	20%	774 W	37.7 V	20.53 A	44.8 V	24.9%
CS7N-650MB-AG	650 W	37.9 V	17.16 A	45.0 V	18.39 A	20.9%
Bifacial Gain**	5%	683 W	37.9 V	18.03 A	45.0 V	22.0%
	10%	715 W	37.9 V	18.88 A	45.0 V	23.0%
	20%	780 W	37.9 V	20.59 A	45.0 V	25.1%
CS7N-655MB-AG	655 W	38.1 V	17.20 A	45.2 V	18.43 A	21.1%
Bifacial Gain**	5%	688 W	38.1 V	18.06 A	45.2 V	22.1%
	10%	721 W	38.1 V	18.93 A	45.2 V	23.2%
	20%	786 W	38.1 V	20.64 A	45.2 V	25.3%
CS7N-660MB-AG	660 W	38.3 V	17.24 A	45.4 V	18.47 A	21.2%
Bifacial Gain**	5%	693 W	38.3 V	18.10 A	45.4 V	22.3%
	10%	726 W	38.3 V	18.96 A	45.4 V	23.4%
	20%	792 W	38.3 V	20.69 A	45.4 V	25.5%

* Under Standard Test Conditions (STC) of irradiance of 1000 W/m², spectrum AM 1.5 and cell temperature of 25°C.

** Bifacial Gain: The additional gain from the back side compared to the power of the front side at the standard test condition. It depends on mounting (structure, height, tilt angle etc.) and albedo of the ground.

ELECTRICAL DATA

Operating Temperature	-40°C ~ +85°C
Max. System Voltage	1500 V (IEC/UL) or 1000 V (IEC/UL)
Module Fire Performance	TYPE 29 (UL 61730) or CLASS C (IEC61730)
Max. Series Fuse Rating	35 A
Application Classification	Class A
Power Tolerance	0 ~ + 10 W
Power Bifaciality*	70 %

* Power Bifaciality = $P_{max, rear} / P_{max, front}$, both $P_{max, rear}$ and $P_{max, front}$ are tested under STC, Bifaciality Tolerance: ± 5 %

ELECTRICAL DATA | NMOT*

	Nominal Max. Power (Pmax)	Opt. Operating Voltage (Vmp)	Opt. Operating Current (Imp)	Open Circuit Voltage (Voc)	Short Circuit Current (Isc)
CS7N-635MB-AG	476 W	35.0 V	13.61 A	42.0 V	14.73 A
CS7N-640MB-AG	480 W	35.2 V	13.64 A	42.2 V	14.77 A
CS7N-645MB-AG	484 W	35.3 V	13.72 A	42.3 V	14.80 A
CS7N-650MB-AG	487 W	35.5 V	13.74 A	42.5 V	14.83 A
CS7N-655MB-AG	491 W	35.7 V	13.76 A	42.7 V	14.86 A
CS7N-660MB-AG	495 W	35.9 V	13.79 A	42.9 V	14.89 A

* Under Nominal Module Operating Temperature (NMOT), irradiance of 800 W/m² spectrum AM 1.5, ambient temperature 20°C, wind speed 1 m/s.

MECHANICAL DATA

Specification	Data
Cell Type	Mono-crystalline
Cell Arrangement	132 [2 x (11 x 6)]
Dimensions	2384 x 1303 x 35 mm (93.9 x 51.3 x 1.38 in)
Weight	37.9 kg (83.6 lbs)
Front / Back Glass	2.0 mm heat strengthened glass
Frame	Anodized aluminium alloy
J-Box	IP68, 3 diodes
Cable	4.0 mm ² (IEC), 10 AWG (UL)
Cable Length (Including Connector)	460 mm (18.1 in) (+) / 340 mm (13.4 in) (-) (supply additional jumper cable: 2 lines / Pallet) or customized length*
Connector	T4 series or MC4-EVO2
Per Pallet	31 pieces
Per Container (40' HQ)	527 pieces or 465 pieces (only for US)

* For detailed information, please contact your local Canadian Solar sales and technical representatives.

TEMPERATURE CHARACTERISTICS

Specification	Data
Temperature Coefficient (Pmax)	-0.34 % / °C
Temperature Coefficient (Voc)	-0.26 % / °C
Temperature Coefficient (Isc)	0.05 % / °C
Nominal Module Operating Temperature	41 ± 3°C

PARTNER SECTION

* The specifications and key features contained in this datasheet may deviate slightly from our actual products due to the on-going innovation and product enhancement. CSI Solar Co., Ltd. reserves the right to make necessary adjustment to the information described herein at any time without further notice.

Please be kindly advised that PV modules should be handled and installed by qualified people who have professional skills and please carefully read the safety and installation instructions before using our PV modules.

CSI Solar Co., Ltd.

199 Lushan Road, SND, Suzhou, Jiangsu, China, 215129, www.csisolar.com, support@csisolar.com

Inverter

Candian

CSI-255K-T800GL02-E

THREE PHASE STRING INVERTER 255 KW



CSI-255K-T800

Canadian Solar's grid-tied, transformer-less string inverters help to accelerate the use of three-phase string architecture for commercial rooftop and small ground-mount applications. An NRTL approved, cost-effective alternative to MLPE, these inverters are modular design building blocks that provide high yield and enable significant BoS cost savings. They provide up to 99.0% conversion efficiency, a wide operating range of 600-1500 V_{DC}, and 14 MPPTs for maximum energy harvest.



standard warranty, extension up to 20 years

KEY FEATURES

- Maximum efficiency of 99.0%
- CEC efficiency of 98.5%
- Fourteen MPPTs to achieve higher system efficiency
- PLC/RS-485 multiple communication modes, flexible monitoring

HIGH RELIABILITY

- IP 66 protection level
- Intelligent redundant air cooling design
- Built in over-voltage and over-current protection
- DC reverse polarity and AC short circuit protection

BROAD ADAPTIBILITY

- Utility interactive controls: Active power derating, reactive power control and over frequency derating
- Integrated DC load rated disconnects
- Wide MPPT range for flexible string sizing
- High switching frequency and ultra fast MPPT for maximum efficiency over a wide load range

CANADIAN SOLAR INC. is committed to providing high quality solar products, solar system solutions and services to customers around the world. No. 1 module supplier for quality and performance/price ratio in IHS Module Customer Insight Survey. As a leading PV project developer and manufacturer of solar modules with over 40 GW deployed around the world since 2001.

For detailed information, please refer to the Installation Manual.

CANADIAN SOLAR INC.

545 Speedvale Avenue West, Guelph, Ontario N1K 1E6, Canada, www.canadiansolar.com

SYSTEM/TECHNICAL DATA

MODEL NAME	CSI-255K-T800GL02-E
DC INPUT	
Max. PV Power	255 KW
Max. DC Input Voltage	1500 V _{DC}
Start-up DC Input Voltage/Power	620 V _{DC}
Number of MPP Trackers	14
MPPT Voltage Range	600 - 1500 V _{DC}
Max. Input Current (Imp)	14*26A
Max. Short Circuit Current (Isc)	14*40A
Number of DC Inputs	14/28
DC Disconnection Type	Load rated DC switch
AC OUTPUT	
Rated AC Output Power	255 KW
Max. AC Output Power	255 KW
Rated Output Voltage*	800 V _{AC}
Grid Connection Type	3W / N / PE
Max Output Current	184.0 A
Rated Output Frequency	50 / 60 Hz
Output Frequency Range*	47 - 52 / 57 - 62 Hz
Power Factor	>0.99 (0.8 leading ... 0.8 lagging)
Current THD	< 3%
DC Injection Current	0.5 % of Rated Grid Output Current
SYSTEM	
Max. Efficiency	99.0 %
CEC Efficiency	98.5 %
Night Consumption	< 2 W
Anti-PID Module	Optional
ENVIRONMENT	
Protection Degree	IP66
Cooling	Intelligent redundant Cooling
Operating Temperature Range	-25 ° C to +60 ° C
Storage Temperature Range	-40 ° C to +80 ° C
Operating Humidity	0 - 100 % condensing
Operating Altitude	4000 m
Audible Noise	<65 dBA @ 1 m
DISPLAY AND COMMUNICATION	
Display	LCD, 2×20 Z
Communication	RS485, Optional:PLC
MECHANICAL DATA	
Dimensions (W / H / D)	1170 x 770 x 384 mm
Weight	113 kg
Installation Angle	0~15 Degrees from Vertical
DC Inputs	MC4
SAFETY	
Safety and EMC Standard	IEC 62109-1/2, IEC 61000-6-1/2/3/4
Grid Standard	IEC 62116, IEC 61727

*The "Rated Output Voltage Range" and "Output Frequency Range" may differ according to specific grid standard.

The specifications and key features contained in this datasheet may deviate slightly from our actual products due to the on-going innovation and product enhancement. Canadian Solar Inc. reserves the right to make necessary adjustment to the information described herein at any time without notice.

Caution: For professional use only. The installation and handling of PV equipment requires professional skills and should only be performed by qualified professionals. Please read the safety and installation instructions before using the product.

CANADIAN SOLAR INC.

545 Speedvale Avenue West, Guelph, Ontario N1K 1E6, Canada, www.canadiansolar.com

Trackers

Convert

PV Horizontal Single Axis Tracker

General technical description

TRJHT30PDP

© COPYRIGHT Convert Italia S.p.A.

All rights reserved

In accordance with the law, this document is the property of CONVERT ITALIA S.p.A. The reproduction or transfer of this document to third parties without our written authorisation is prohibited.

TABLE OF CONTENTS

- 1. SCOPE OF THE DOCUMENT..... 2
- 2. INTRODUCTION 3
- 3. NOTABLE CHARACTERISTICS 4
 - 3.1 MAIN CHARACTERISTICS..... 5
 - 3.1.1 Durability and protective treatment of steel components..... 6
 - 3.1.2 Driven Pile 6
 - 3.1.3 Post-Head Component 7
 - 3.1.4 Adjustment and Error Recovery 7
 - 3.1.5 Auto-Configuring Control Board 8
 - 3.1.6 Linear Actuator Management – Self powered 10
- 4. TECHNICAL SPECIFICATIONS – PROJECTS IMPLEMENTATION..... 11
 - 4.1 ELECTRICAL SPECIFICATIONS (SUBFIELD OF 10 TRACKERS) 11
 - 4.2 TRJ – BILL OF MATERIALS 13
 - 4.3 MAINTENANCE 13
 - 4.4 OTHER CHARACTERISTICS 13
- 5. SCADA CONTROL SYSTEM..... 14
 - 5.1 GENERAL DESCRIPTION 14
 - 5.2 HARDWARE ARCHITECTURE 14
 - 5.3 SOFTWARE ARCHITECTURE 15

1. SCOPE OF THE DOCUMENT

This document describes the main characteristics of the design and components of pv horizontal single axis tracker, typical wiring specifications and possible system implementation for following tracker:

TRJHT30PDP (1500V – 1 String each tracker)

All components and structures will be designed for the specific environmental conditions of the sites according to the local regulations and following the technical requests including the design hypothesis of wind load.

2. INTRODUCTION

Convert developed the solar tracker TRJ for East–West solar tracking with the goal of maximising the energy and cost efficiency of a photovoltaic plant's ground-mounted pv crystalline silicon panels. This goal was achieved over ten years ago, resulting in a single product that guarantees the advantages of a solar tracking solution and simple installation and maintenance like that of driven-post of fixed array.

The **horizontal single axis tracker**, using electromechanical devices follows the sun during all day long from East to West on axis of rotation horizontal North - South (tilt 0°). Field layouts with horizontal single axis trackers are very flexible. The simple geometry means that keeping all of the axis of rotation parallel to one another is all that is required for appropriately positioning the trackers with respect to one another.

The **backtracking** system checks and ensures that a string of panels does not shade other adjacent panels. When the Sun's elevation angle is low in the sky, early or late in the day, self-shading between tracker rows as potential to reduce system output.

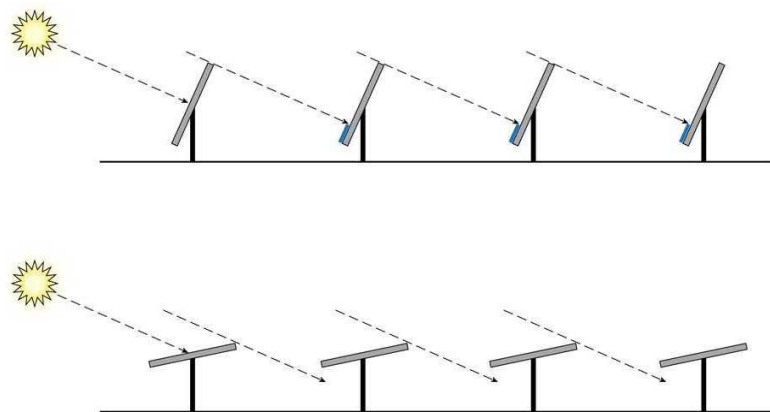

Figure 1: Backtracking

Backtracking rotates the array aperture away from the Sun, eliminating deleterious effects of self-shading and maximizing ground coverage ratio. Thanks to this feature, the centre distance between the various strings can be reduced.

Thus, the entire PV plant occupies less land than those employing similar tracking solutions. The absence of tilt movement, (i.e., "seasonal" tracking) has little effect on energy output and allows for a much simpler mechanical structure that makes for an inherently reliable system. This simplified desing results in higher energy capture at a similar cost to a fixed array. With the potential for 15% to 35% improvement in energy production, the introduction of a cost-effectivie tracking technology facilitated the development of utility-scale PV systems.

3. NOTABLE CHARACTERISTICS

The product's key feature lies in the engineering: a solution that employs widely available, off-the-shelf mechanical components (steel profiles) and electronics to seamlessly work with the product's "proprietary" accessories (articulating post-heads, motors driving their movement and an electronic control board managing the motors).

This solution provides the following main advantages:

- **Completely balanced and modular**, the structure does not require specialized personnel for installation and assembly or maintenance works.
- **Easy to install** and self-configuring control board. The integrated GPS always triggers the right geographical location to the system for solar automatic tracking.
- Spherical self-lubricated plain bearing of Convert design to **compensate inaccuracies and error in mechanical structure installation**.
- **Independent raw** solution, with unique independent double dust protection ring **AC motor**.
- **Low electric consumption**.

The advent of these unique solutions distinguishes the TRJ from other types of trackers on the market, achieving a most advantageous cost/performance ratio.



Figure 2: Intermediate Post-Head Detail

3.1 MAIN CHARACTERISTICS

The structure of the TRJ tracker is completely adaptable according to pv panel dimensions, the geotechnical condition of the specific site and the amount of installation space available.

The electrical configuration of the strings requires the following table configuration of tracker with pv modules available in portrait:

Structure 1x30 pv modules available in portrait (9.9 kWp)

- Dimension (L) 30.73 m x 1.96 m x (H) max .2.12 m
- Steel structure mechanical components: 5 posts (usually around 3 m high including foundations) and 4 square tubulars (dimensional specifications vary according to terrain and wind and are included in the technical specifications established during the project's preliminary design). Supporting Omega profile and panel anchoring.
- Movement proprietary components: 5 post-heads (2 for end and intermediate posts and 1 supports the motor). An electronic control board for movement (one board can serve 10 structures). 1 motor (AC electric linear (spindle) actuator).
- The distance between the trackers (I) will be set according to project specifications.
- The minimum height from the ground (D) is: 0.5 m
- Each complete tracking structure including ramming piles foundations weighs around 600 kg.
- An average of 101 trackers (with pv-modules 330 W_p) are required for a 1 MW_p plant.

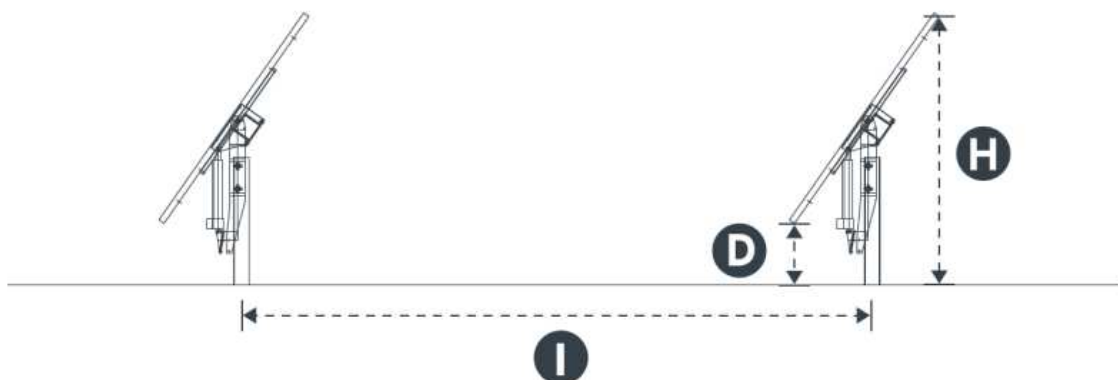

Figure 3: Dimensional definitions

3.1.1 Durability and protective treatment of steel components

Considering the table below and the corrosive environment classification and considering a minimum design life of 25 years, **foundation posts will be hot dip galvanized according to EN ISO 1461:2009, other parts will be hot dip galvanized or pregalvanized (Sendzmir) according to project specifications.**

Environmental Categories	Possibility of Corrosion	Type of Environment	Loss off coating $\mu\text{m}/\text{year}$
C ₁	Very Low	Internal: dry	0.1
C ₂	Low	Internal: occasional condensation Outdoor: rural areas	0.7
C ₃	Medium	Internal: humidity Outdoor: urban areas	2.1
C ₄	High	Internal: pools, chemical plants Outdoor: industrial or marine atmosphere	3.0
C ₅	Very High	Outdoor: Highly saline marine atmosphere or industrial area with damp climates	6.0

3.1.2 Driven Pile

The driven post support does not require a concrete foundation. The post is a steel omega profile to maximize the contact surface with the ground, depth is depending on the type of land. A typical 5 cm flange is used for driving the post with a post driver that should have a guide to maintain insertion direction within minimum tolerances.



Figure 4: Driving omega piles phase

3.1.3 Post-Head Component

The post-head component kit can be installed directly on the driven foundation posts with no on-site welding. In compliance with the most stringent environmental constraints, this solution eliminates the need for concrete foundations, which also reduces construction time.

3.1.4 Adjustment and Error Recovery

The position adjustment on the ground takes place near the foundations and rotation is at the upper part of the structure. The TRJ solution has a single machined component that provides both rotational movement and position-alignment adjustment. This is possible thanks to a spherical plain bearing (similar to components used in industrial actuation systems) incorporated into a "sandwich" that connects the foundation posts to the main crosspieces.

The driven-post foundation has become a standard in the field of photovoltaics. More easily constructed than those with foundation screws, these forego the use of concrete, which has been banned by many local and national regulations. Yet, the driven posts are just as easy to remove as foundation screws.

A driven-post installation has some inherent placement error, especially when the post is more than one metre above ground. The post-head has slotted screw holes to achieve a mounting position that compensates for post placement error, and thus restores east–west inclination. The spherical plain bearings allows for the recovery of north–south inclination. Connecting to the crosspieces with clamps reduces the distance between posts and does not require additional holes in the beams themselves.

The driven-post can accept the following installation errors, even occurring simultaneously:

- a) **± 20 mm of error in height**

From the exact point of the pole driving to the ideal alignment point considering the other poles in the tracker structure:

- b) **± 35 mm of error in North/South**
- c) **± 20 mm of error in East/West**
- d) **± 2° of error in inclination**, comparing to the ideal vertical line (driving angle).
This error extends the total tolerance when added up to the previous (see point b).
- e) **± 5° of error in rotation**, comparing to the ideal vertical line that aligns all the flanges of the other poles in the complete tracker structure.

All the tolerance above can be accepted also in addition to the following soil non ideal conditions:

Land Grading: $\pm 3^\circ$ North/South (optionally up to $\pm 8^\circ$) – No limitation East/West
Punctual soil nonuniformity: ± 100 mm

3.1.5 Auto-Configuring Control Board

A control board was specifically designed to simplify the installation process as much as possible. At the moment of initial power-on, the activation and commissioning phase is simplified by automatic recognition of the installation location and time; tracking also begins automatically. Moreover, following a mains failure, the system is capable of restoring the optimal tracking angle.

At initial power-on, the control board guides the installer (via PC interface) through steps to calibrate motor parameters.

Additionally, the integrated GPS automatically acquires position of the plant, date and time. Such information, along with astronomical clock algorithms, is enough to identify and properly track the position of sun. The GPS is always active and continually updates the information; thus, plant installation errors cannot compromise proper tracking. Due to its characteristics, the control board is autonomous and thus does not require a plant-level control unit for operation. Malfunctions are signalled via an indicator light, a voltage-free contact or via wireless communication. The system is equipped with local control pad for manual commands. In order to reduce cost and increase reliability, the control board is equipped with 10 outputs to control 10 motors (electric linear actuators). *A single control board can thus drive 10 structures*, for a photovoltaic energy capacity until around 99 kWp (with 30 modules configuration and 330 W -72 Cells modules).

LINEAR ACTUATOR CONTROL OUTPUT

N°10 power output for the control of the photovoltaic linear actuators

AC Single phase asynchronous brushless motor 230/240 V

Thermal Relay for Motor protection

CONNECTION INPUT

N° 20 input for free-voltage contacts for the connection to the linear actuator limit (2 inputs for each actuator)

Over-voltage protection, 40 A – 400 W – waveform 10/1000us

Electrical insulation 890 V

GPS

GPS antenna for the automatic capture of tracker's working parameters (astronomical clock)

RS232 interface with Over-voltage protection 120 A – 0.2 J

Integrated antenna and receiver

20 simultaneous channels

FAILURE ALERTS

Fault output signaling relay, free-voltage contact 5 A, isolation 4 kV
Status signal via n°3 LED integrated on the board
External fault light (red led)
Integrated buzzer

WIRELESS COMMUNICATION (OPTIONAL)

Wireless Transceiver integrated in every SKC
Modbus Standard communication protocol

RS232 INTERFACE

Local user interface via DB9 PC connection
Over-voltage protection 120 A – 0.2 J
MS-Windows Configuration software

ANEMOMETER

Wind speed control through anemometer
N° 3 blades case, size 125 x 117 mm

LINEAR ACTUATORS

Actuator force 10000 N (40000 N emergency)
Stroke of 370 mm

OTHER CHARACTERISTICS

Autonomous management through micro controller 32 bit – 100 MHz – 512 kB flash
Electronic static motor controller (SSR)
Automatic restart after a power failure.
Buttons on the board for the manual control of the linear actuators (east/west)
M.T.B.F. 2000000 hours
Additional cover for bad weather and uv-rays;
Motor's power factor correction capacitors integrated
Annual consumption 1 kWh/year

MECHANICAL CHARACTERISTICS

Supporting plate for the connection on the tracker's central pole (motor pole)
Electronic board size 300 x 165 mm
Box size 240 x 310 x 110 mm
Weight 5 kg
Degree of protection IP55

ENVIRONMENTAL CHARACTERISTICS

Operating temperature Wide Range -10°C +55°C
Operating altitude < 2000 m asl
Natural cooling without external air exchange
Outdoor Equipments are class II insulated
Outdoor Equipments are UV-rays protected

3.1.6 Linear Actuator Management – Self powered

An AC motor with linear actuator is installed on each structure, obtaining a higher level of reliability comparing with commercial DC motor. Other configuration respecting electrical lines rules and standards are suitable as well.

The motor supply is directly from PV power through one electrical strings : this is the most innovative component, unique in the market. This solution will allow to remove the wiring 230V or any other kind of power supply cables on site, and can supply the motors even in the absence of the sun and by night. No battery are needed for selfpower operation

PV Voltage (1500V)

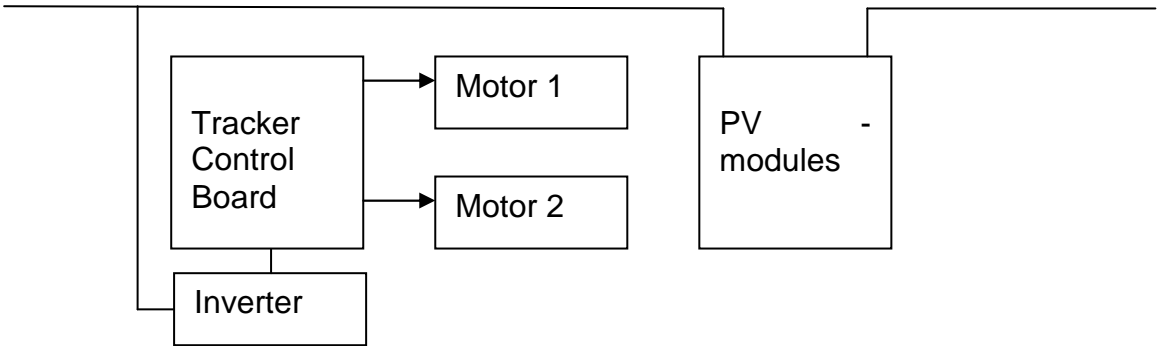

Each SKC feeds up to 10 motors using standard 7 poles cable. When the motor fails, a significant portion of the solar field goes out of service. Replacing the heavy motor is also cumbersome. Further, the mechanical movement of these systems can become quite stiff due to atmospheric phenomena. These systems are also subject to obstruction by moving vehicles and technicians.

The system with 1 control board and 10 linear actuators allows the electrical cables to be passed through underground conduits. In the case of a failure, the control board is replaced in just 20 minutes and the motor in just 15 minutes. Further, conformation of the ground has little effect on installation. In fact, an East–West grade has no impact on string installation. In the case of a north–west grade, a tracker can handle slopes of up to 5%.



Figure 5: AC Linear Actuator and SKC control board detail

4. TECHNICAL SPECIFICATIONS – PROJECTS IMPLEMENTATION

Considering sites specifications, proposed preliminary configuration for the PV plant (may vary after receiving more specific information), as discussed above, we propose according to single projects, 1x30 structures.

Following technical specifications are according with Tender Specifications.

4.1 ELECTRICAL SPECIFICATIONS (SUBFIELD OF 10 TRACKERS)

Given the electronic control board's configuraton (1 board x 10 motors), a subfield can have a nominal power between 99 kWp (30 PV-modules x 330 W x 10 trackers).

The structures are driven by AC electric linear actuators, two supply voltages are available: 230 V, single-phase 50 Hz (CE, UL listed) or an optional 240 V, 60 Hz (UL listed). Motor control is timed to minimise wear.

Tracking Type	Single-Axis, 0°-Tilt
Tracking Angle	± 60°
Control Type	Astronomical Clock (no sensors required)
Tracking Error	± 2° (0,030% power loss at maximum error)
Control System Architecture	Operation with 1 electronic control board for 10 trackers with built-in GPS for automatic acquisition of astronomical clock parameters.
Motor	<ul style="list-style-type: none"> • Timed motor control to minimise wear • 5.6 kWh/year power consumption
Control board for 10 motors	<ul style="list-style-type: none"> • 1 kWh/year power consumption • RS232 diagnostic interface with PC management software • Alerts via voltage-free contact • Anemometer input (modules return to horizontal position in the event of strong winds) • Integrated wireless transceiver
<u>Max electric consumption</u>	<u>< 0,016 kWh/day per tracker</u>

Wind speed limits and defensive System

- Wind resistance up to 72 km/h valid for any working position (± 60°)
- Wind resistance up to 120 km/h in stow position in the case of 15° automatic positioning for smaller surface area.
- Wind speed to activate defence mechanism: 60 km/h
- Time to go from 60° to 0° tilt: 100 sec.

All values about wind resistance or defence mechanism have to be considered as minimum values. Effective setting values will be in conformity with Project National Norms.

4.2TRJ – BILL OF MATERIALS

TRJHT30PDP (1x30 - 330 W 72 cell pv modules selection)

KIT movement components for a subfield of 10 trackers

- 10 motor Pile Head with linear actuator and mechanical parts to be fixed to n°1 pile and n°2 beams
- 20 ending Pile Head with mechanical parts to be fixed to n°1 pile and n°1 beams
- 20 middle Pile head with mechanical parts to be fixed to n°1 pile and n°2 beams
- 1 electronic motor control boards, structure mounting plates, counter-plates, washers, GPS antennas
- 10 mechanical accessories kit for component mounting
- 10 electric linear actuators (with installation kit tools)

Steel mechanical components for 10 trackers

- 50 Driven piles
- 40 Cross bars square tubular (7 m)
- 380 PV-module support omega rails
- 380 Short and Long plate

4.3 MAINTENANCE

- Electric actuators require no maintenance or lubrication.
- End-of-day self-diagnostics signalled through change-over contact and buzzer
- Expected motor life: 30 years
- Expected galvanised barrier life: 25 years

4.4 OTHER CHARACTERISTICS

- Compatible with Italian Machinery Directive 2006/42/EC
- CE listed
- Both 50Hz and 60 Hz version also UL listed
- All tracking control components are TÜV SÜD certified.
- Simple installation, commissioning and maintenance that require no special equipment; instructions guide the installer through all phases; interface software supplied as standard, allows system diagnostics.
- Patents RM2007A000683 and PD2012A0, International Patent PCT/IB2013/054425

5. SCADA CONTROL SYSTEM

5.1 GENERAL DESCRIPTION

The PV SUPERVISOR™ control and photovoltaic management system has been developed by Convert in order to monitor with a real time remote communication the TRJ trackers installed inside the PV plant succeeding in :

Measure, collect and record the moving values of all trackers.

Communicate remotely to a remote operator connected to the network using the VNC protocol.

Respond to the requests from an external master through MODBUS TCP protocol.
Supply all the information to a local operator (substation) via display and keyboard, in particular:

- Report possible malfunctions or alarms.
- Give remote commands to each tracker.

The main performance data are highlighted with a simplicity and visual immediacy

5.2 HARDWARE ARCHITECTURE

The PV SUPERVISOR™ uses the fiber optic links available in the plant. These links are placed so as to create a ring in single modal fiber. The optic connectors used are SC type.

The control panel also includes the operator interface with a monitor, keyboard and touchpad in rack of 19 inches.

The control panel is located in the substation and connected to peripheral devices in LAN with standard 100Base-FX made with fiber optic connections as mentioned above. They can be connected up to 128 peripheral devices, hosted in the of MT/BT cabins arranged on the plant.

The peripheral boards is housed inside the inverter cabins and powered 24 Vdc.

Each peripheral board can have inside several peripheral devices. In wireless option each peripheral device is equipped with antenna and transceiver and each control board equipped with wireless antenna will communicate with the peripheral board trough Wireless transmission.

5.3 SOFTWARE ARCHITECTURE

SW architecture of PV SUPERVISOR™ è schematically shown in the following figure:

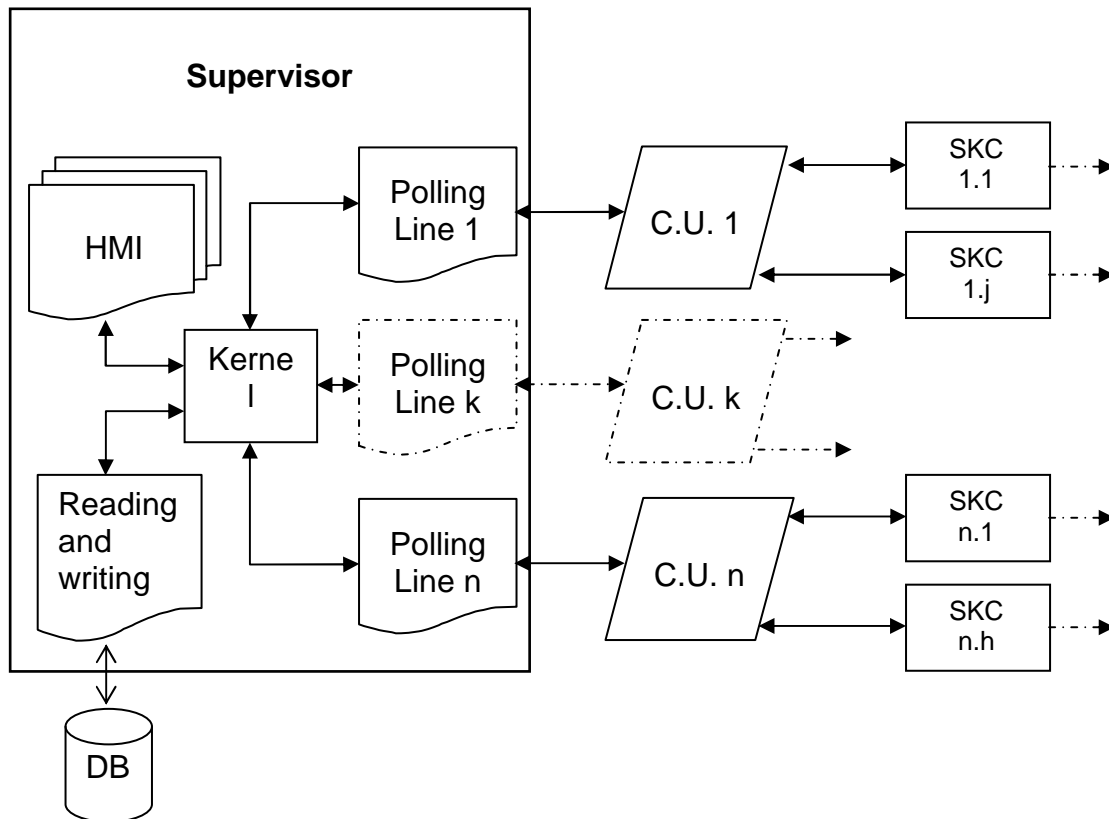

Figure 6: SW Architecture of the Supervisor

A kernel manages the different activities of the Supervisor:

- Communication with the user through windows (HMI), as outlined later
- Reading and writing data on database
- Polling of each tracker and reception of status data through the HW structure described in the previous chapter

Polling is performed at regular intervals established during the activation phase. The Supervisor polls in parallel all the communication lines in order to receive the data of each tracker installed. So doing the PV SUPERVISOR™ is always updated.

The values related to the measurements are then averaged and stored every 15 minutes on the database so that they can be recalled afterwards.

The status information, on the other hand, are stored on the database every time there is a status change (start and end of alarm).

Cavi MT BT Solari

Giunti MT

ARG7H1RX-12/20 kV

ARG7H1RX-18/30 kV

Costruzione, requisiti elettrici, fisici e meccanici:	CEI 20-13 IEC 60502-2
Misura delle scariche parziali:	CEI 20-16 IEC 60885-3
Non propagazione della fiamma:	EN 60332-1-2
Gas corrosivi o alogenidrici:	EN 50267-2-1



Descrizione

- Cavi tripolari precordati, isolati in gomma HEPR di qualità G7, sotto guaina di PVC.
- Conduttore: alluminio, formazione rigida compatta, classe 2
- Strato semiconduttore interno: estruso
- Isolamento: gomma HEPR, qualità G7 senza piombo
- Strato semiconduttore: estruso, pelabile a freddo
- Schermo: fili di rame rosso con nastro di rame in controspirale
- Guaina: miscela a base di PVC, qualità Rz
- Colore: rosso

Caratteristiche funzionali

- Tensione nominale di esercizio U_o/U:
 - ARG7H1RX -12/20 kV: 12/20 kV
 - ARG7H1RX -18/30 kV: 18/30 kV
- Tensione U max:
 - ARG7H1RX -12/20 kV: 24 kV
 - ARG7H1RX -18/30 kV: 36 kV
- Temperatura massima di esercizio: 90°C
- Temperatura minima di esercizio: -15°C (in assenza di sollecitazioni meccaniche)
- Temperatura massima di corto circuito: 250°C

Marcatura

Pb free LA TRIVENETA CAVI ARG7H1RX [tens. nominale] [form.] [anno] [ordine] [metrica] FASE 1/2/3

Condizioni di posa

- Temperatura minima di posa: 0°C
- Raggio minimo di curvatura consigliato: 10 volte il diametro del cavo
- Massimo sforzo di trazione consigliato: 50 N/mm² di sezione del conduttore

Impiego e tipo di posa

Adatto per il trasporto di energia tra le cabine di trasformazione e le grandi utenze. Per posa in aria libera, in tubo o canale.

Ammessa la posa interrata in conformità all'art. 4.3.11 della norma CEI 11-17.

ARG7H1RX - 12/20 kV

U_o/U: 12/20 kV

U max: 24 kV

Caratteristiche tecniche

Formazione	Ø indicativo conduttore	Spessore medio isolante	Spessore medio guaina	Ø indicativo anima	Ø ciroscritto indicativo	Peso indicativo cavo	Portata di corrente A	
							in aria	interrato ^(*)
n° x mm ²	mm	mm	mm	mm	mm	kg/km	A	A
3 x 1 x 35	7,0	5,5	1,8	26,9	57,8	2250	144	142
3 x 1 x 50	8,1	5,5	1,8	28,1	60,4	2465	174	168
3 x 1 x 70	9,7	5,5	1,8	29,8	64,1	2875	218	207
3 x 1 x 95	11,4	5,5	1,9	31,9	68,5	3255	266	247
3 x 1 x 120	12,9	5,5	2,0	34,2	73,5	3780	309	281
3 x 1 x 150	14,3	5,5	2,0	35,8	77,0	4025	352	318
3 x 1 x 185	16,0	5,5	2,1	37,8	81,3	4685	406	361
3 x 1 x 240	18,3	5,5	2,2	41,0	88,2	5540	483	418
3 x 1 x 300	21,0	5,5	2,3	44,0	94,5	6365	556	472

(*) I valori di portata si riferiscono alle seguenti condizioni:

- Resistività termica del terreno: 1 K·m/W
- Temperatura ambiente 20°C
- profondità di posa: 0,8 m

Caratteristiche elettriche

Formazione	Resistenza elettrica a 20°C	Resistenza apparente a 90°C e 50Hz	Reattanza di fase	Capacità a 50Hz
n° x mm ²	Ω/Km	Ω/Km	Ω/Km	μF/km
3 x 1 x 35	0,868	1,113	0,14	0,17
3 x 1 x 50	0,641	0,822	0,13	0,18
3 x 1 x 70	0,443	0,568	0,13	0,21
3 x 1 x 95	0,320	0,411	0,12	0,23
3 x 1 x 120	0,253	0,325	0,12	0,25
3 x 1 x 150	0,206	0,265	0,11	0,27
3 x 1 x 185	0,164	0,211	0,11	0,29
3 x 1 x 240	0,125	0,161	0,11	0,32
3 x 1 x 300	0,100	0,130	0,10	0,35

ARG7H1RX - 18/30 kV

U_o/U: 18/30 kV

U max: 36 kV

Caratteristiche tecniche

Formazione	Ø indicativo conduttore	Spessore medio isolante	Spessore medio guaina	Ø indicativo anima	Ø ciroscritto indicativo	Peso indicativo cavo	Portata di corrente A	
							in aria	interrato ^(*)
n° x mm ²	mm	mm	mm	mm	mm	kg/km	A	A
3 x 1 x 35	7,0	8,0	1,9	33,5	72,0	3150	144	142
3 x 1 x 50	8,1	8,0	2,0	34,1	73,3	3480	174	168
3 x 1 x 70	9,7	8,0	2,0	36,2	77,8	3880	218	207
3 x 1 x 95	11,4	8,0	2,1	38,2	82,1	4355	266	247
3 x 1 x 120	12,9	8,0	2,2	40,0	86,0	5020	309	281
3 x 1 x 150	14,3	8,0	2,2	41,0	88,2	5385	352	318
3 x 1 x 185	16,0	8,0	2,3	43,1	92,7	6040	406	361
3 x 1 x 240	18,3	8,0	2,4	45,0	96,8	6910	483	418

(*) I valori di portata si riferiscono alle seguenti condizioni:

- Resistività termica del terreno: 1 K·m/W

- Temperatura ambiente 20°C

- profondità di posa: 0,8 m

Caratteristiche elettriche

Formazione	Resistenza elettrica a 20°C	Resistenza apparente a 90°C e 50Hz	Reattanza di fase	Capacità a 50Hz
n° x mm ²	Ω/Km	Ω/Km	Ω/Km	μF/km
3 x 1 x 35	0,868	1,113	0,14	0,17
3 x 1 x 50	0,641	0,822	0,13	0,18
3 x 1 x 70	0,443	0,568	0,13	0,21
3 x 1 x 95	0,320	0,411	0,12	0,23
3 x 1 x 120	0,253	0,325	0,12	0,25
3 x 1 x 150	0,206	0,265	0,11	0,27
3 x 1 x 185	0,164	0,211	0,11	0,29
3 x 1 x 240	0,125	0,161	0,11	0,32

Giunzioni e Terminazioni per Cavi



ad isolante estruso sino a 36 kV max

Giunzioni: Tecnologie Tradizionali a resina iniettata e nastri

- Corredi per l'esecuzione di giunzioni in linea su cavi unipolari, tripolari ad isolante estruso con conduttore in alluminio e rame
- Ottima protezione meccanica
- Approvazioni CEI 20-24/81

Giunzioni con nastri e resine

- Serie 1600: adatte per posa interrata

Corredi per l'esecuzione di giunzioni in linea a resina iniettata su cavi unipolari ad isolante estruso o politene reticolato con conduttori in rame o alluminio. La ricostruzione dell'isolamento avviene mediante nastro di gomma autovulcanizzante; la protezione meccanica esterna realizzata con nastro spaziatore e resina iniettata a stato finale solido. Le giunzioni risultano pertanto totalmente

impermeabili e meccanicamente protette, ciò le rende adatte alla posa interrata diretta anche in presenza di alcali e acidi presenti nel terreno. I corredi non contengono i connettori.

APPROVAZIONI:
CEI 20-24/81.

Cavi unipolari tipo: (A) RG5H1R-(A) RE4H1E-R-(A) RG7H1R

Tipo	Tensione nominale/ massima U ₀ /U kV Um	Sezione mm ²	Dimensioni (mm)			
			L		D	
			min	max	min	max
GL1SER1615/300	8,7/15-17,5	25 ÷ 300	620	750	60	85
GL1SER1615/630	8,7/15-17,5	400 ÷ 630	660	770	90	100
GL1SER1620/300	12/20-24	25 ÷ 300	660	790	65	90
GL1SER1620/630	12/20-24	400 ÷ 630	700	810	95	105
GL1SER1630/300	18/30-36	25 ÷ 300	740	870	70	95
GL1SER1630/630	18/30-36	400 ÷ 630	780	890	100	110

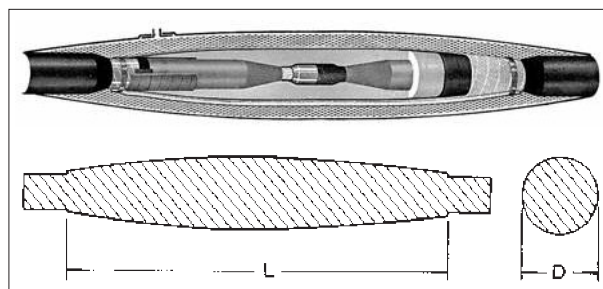

Cavi tripolari tipo: (A) RG5H10R-(A) RE4H10E-R-(A) RG7H10R

Tipo	Tensione nominale/ massima U _o /U kV Um	Sezione mm ²	Dimensioni (mm)			
			L		D	
			min	max	min	max
GL3SER1615/ 50	8,7/15-17,5	25 ÷ 50	870	930	100	120
GL3SER1615/300	8,7/15-17,5	70 ÷ 300	880	1010	120	130
GL3SER1620/ 50	12/20-24	25 ÷ 50	910	970	110	140
GL3SER1620/300	12/20-24	70 ÷ 300	920	1050	130	180
GL3SER1630/ 50	18/30-36	25 ÷ 50	990	1050	120	150
GL3SER1630/300	18/30-36	70 ÷ 300	1000	1090	140	190

N.B.: Nei corredi non sono compresi i connettori

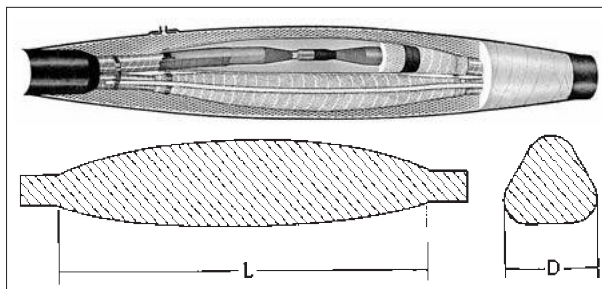

Giunzioni solo in resina

- Serie 1700-1800: adatte per posa interrata

Questi corredi sono adatti ad eseguire giunzioni in linea a resina iniettata su cavi unipolari ad isolante estruso con conduttore in rame o alluminio. L'isolamento e la protezione meccanica della giunzione vengono realizzate da una struttura rigida costituita da nastro spaziatore e resina isolante a stato finale solido. Tale struttura li rende

particolarmente adatti alla posa interrata diretta, anche in presenza di alcali e acidi presenti nel terreno.

APPROVAZIONI:
CEI 20-24/81.

Cavi unipolari tipo: (A) RG5H1R-(A) RG7H1R

Tipo	Tensione nominale/ massima U _o /U kV Um	Sezione mm ²	Dimensioni (mm)			
			L		D	
			min	max	min	max
GL1SER1710/300	6/10-12	25 ÷ 300	555	665	60	80
GL1SER1710/630	6/10-12	400 ÷ 630	595	690	85	95
GL1SER1720/300	12/20-24	25 ÷ 300	595	705	70	90
GL1SER1720/630	12/20-24	400 ÷ 630	635	730	95	105
GL1SER1730/300	18/30-36	25 ÷ 300	695	845	80	100
GL1SER1730/630	18/30-36	400 ÷ 630	775	870	105	110

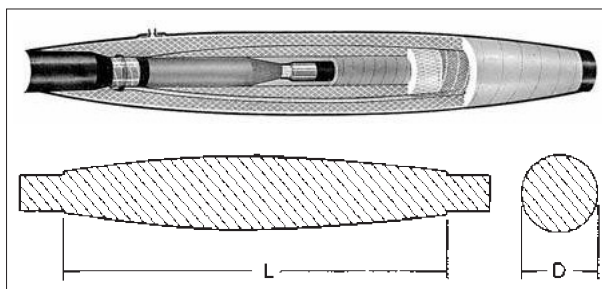

Cavi tripolari tipo: (A) RG5H10R-(A) RG7H10R

Tipo	Tensione nominale/ massima U _o /U kV Um	Sezione mm ²	Dimensioni (mm)			
			L		D	
			min	max	min	max
GL3SER1810/ 95	6/10-12	25 ÷ 95	625	700	95	115
GL3SER1810/240	6/10-12	120 ÷ 240	665	760	120	130
GL3SER1820/ 95	12/20-24	25 ÷ 95	685	760	100	120
GL3SER1820/240	12/20-24	120 ÷ 240	725	815	125	135

N.B.: Nei corredi non sono compresi i connettori

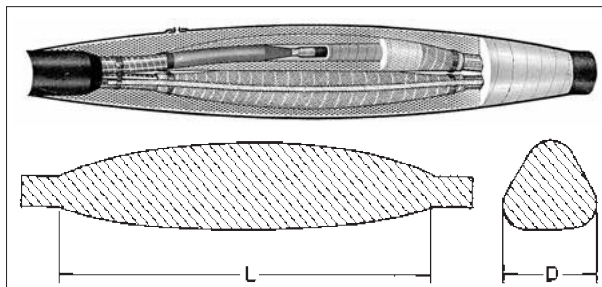

Giunzioni solo nastrate

- Serie 1900: adatte per posa in passerella o gallerie

Corredi per l'esecuzione di giunzioni in linea nastrate su cavi unipolari (GL1 SER-1900) e tripolari (GL3 SER-1900) ad isolante estruso, con conduttore in rame o alluminio. L'isolamento viene ricostituito mediante un nastro di gomma autovulcanizzante (Scotch 23), mentre tutte le altre caratteristiche del cavo vengono ripristinate mediante una serie di nastri speciali contenuti nel corredo. Essendo, questi tipi di giunzione, privi di protezione meccanica esterna rigida, sono adatte per posa su

passerelle o in cunicoli. Sono inoltre, particolarmente indicate per eseguire giunzioni per linee aeree su cavi ecologici ad isolante estruso. Non devono essere utilizzate per posa interrata diretta. Non sono previsti nei corredi i connettori.

APPROVAZIONI:
CEI 20-24/81.

Cavi unipolari tipo: (A) RG5H1R-(A) RE4H1E-R-(A) RG7H1R

Tipo	Tensione nominale/ massima U _o /U kV U _m	Sezione mm ²	Dimensioni (mm)			
			L		D	
			min	max	min	max
GL1SER1915/300	8,7/15-17,5	25 ÷ 300	615	730	40	65
GL1SER1920/300	12/20-24	25 ÷ 300	635	750	45	70
GL1SER1930/300	18/30-36	25 ÷ 300	715	830	50	75

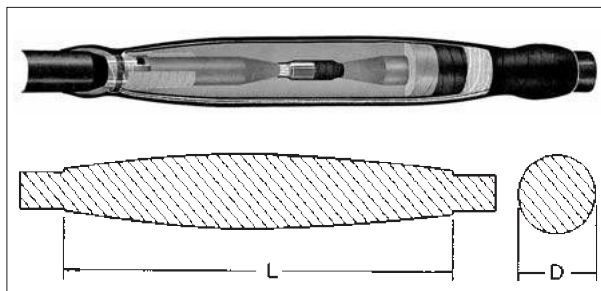

Cavi tripolari tipo: (A) RG5H10R-(A) RE4H10E-R-(A) RG7H10R

Tipo	Tensione nominale/ massima U _o /U kV U _m	Sezione mm ²	Dimensioni (mm)			
			L		D	
			min	max	min	max
GL3SER1915/150	8,7/15-17,5	25 ÷ 150	765	945	80	105
GL3SER1920/150	12/20-24	25 ÷ 150	805	985	85	110
GL3SER1930/150	18/30-36	25 ÷ 150	855	1070	90	115

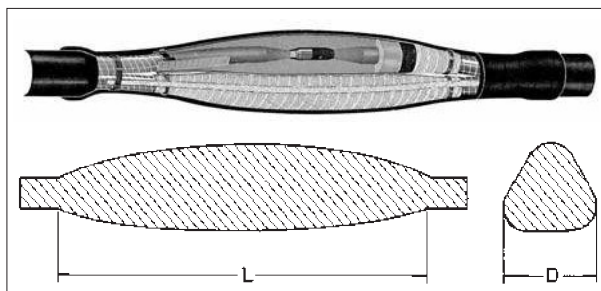

N.B.: Nei corredi non sono compresi i connettori

ARG16R16-0,6/1 kV

REAZIONE AL FUOCO



CONFORME CPR
REGOLAMENTO 305/2011/UE

Norma:	EN 50575:2014+A1:2016
Classe:	C _{ca} -s3, d1, a3
Classificazione: (CEI UNEL 35016)	EN 13501-6
Emissione di calore e fumi e sviluppo della fiamma	EN 50399
Non propagazione della fiamma:	EN 60332-1-2
Gas corrosivi e alogenidrici:	EN 60754-2
Organismo Notificato:	0051 - IMQ
CE	2018

Costruzione, requisiti elettrici CEI 20-13
fisici e meccanici:

Gas corrosivi o alogenidrici: EN 50267-2-1

Direttiva Bassa Tensione: 2014/35/UE

Direttiva RoHS: 2011/65/UE



Descrizione

- Conduttore: alluminio, corda rigida compatta, classe 2
- Isolamento: gomma, qualità G16
- Riempitivo: termoplastico
- Guaina: PVC, qualità R16
- Colore: grigio

Caratteristiche funzionali

- Tensione nominale U_0/U : 600/1000 V c.a.
1500 V c.c.
- Tensione massima U_m : 1200 V c.a.
1800 V c.c. anche verso terra
- Tensione di prova industriale: 4000 V
- Temperatura massima di esercizio: 90°C
- Temperatura minima di esercizio: -15°C
(in assenza di sollecitazioni meccaniche)
- Temperatura massima di corto circuito: 250°C

Caratteristiche particolari

Buona resistenza agli oli e ai grassi industriali. Buon comportamento alle basse temperature.

Colori delle anime

UNIPOLARE



Marcatura

Made in Italy LA TRIVENETA CAVI ARG16R16 0,6/1 kV [form.] Cca-s3,d1,a3 [anno] [ordine] [metrica]

Condizioni di posa

- Temperatura minima di posa: 0°C
- Raggio minimo di curvatura consigliato: 6 volte il diametro del cavo
- Massimo sforzo di trazione consigliato: 50 N/mm² di sezione del conduttore

Impiego e tipo di posa

Adatto per il trasporto di energia nell'industria, nei cantieri, nell'edilizia residenziale.

Per installazione fissa all'interno e all'esterno, su murature e strutture metalliche, su passerelle, tubazioni, canalette e sistemi similari.

Ammessa la posa interrata, anche se non protetta.

Riferimento Regolamento Prodotti da Costruzione 305/2011 EU e Norma EN 50575:

Date le proprietà di limitare lo sviluppo del fuoco e l'emissione di calore, il cavo è adatto per l'alimentazione di energia elettrica nelle costruzioni ed altre opere di ingegneria civile.

Formazione	Ø indicativo conduttore	Spessore medio isolante	Spessore medio guaina	Ø esterno max	Resistenza elettrica max a 20°C	Peso indicativo cavo	Portata di corrente A					
							in aria a 30°C	in tubo in aria a 30°C	interrato a 20°C		tubo interrato a 20°C	
n° x mm ²	mm	mm	mm	mm	Ω/km	kg/km			K = 1	K = 1,5	K = 1	K = 1,5
1 x 16	4,90	0,7	1,4	10,0	1,91	150	70	64	98	89	75	70
1 x 25	6,10	0,9	1,4	11,7	1,20	185	102	88	119	110	95	88
1 x 35	7,10	0,9	1,4	13,0	0,868	220	136	110	141	131	115	106
1 x 50	8,20	1,0	1,4	14,7	0,641	280	164	131	167	154	134	124
1 x 70	9,90	1,1	1,4	16,6	0,443	320	218	175	204	189	173	160
1 x 95	11,40	1,1	1,5	18,6	0,320	460	261	209	245	226	196	181
1 x 120	13,10	1,2	1,5	20,5	0,253	570	310	250	277	256	238	220
1 x 150	14,40	1,4	1,6	22,8	0,206	670	350	280	313	289	250	231
1 x 185	16,20	1,6	1,6	25,0	0,164	810	415	334	350	324	300	278
1 x 240	18,40	1,7	1,7	27,9	0,125	1025	490	392	413	382	331	306
1 x 300	20,65	1,8	1,8	30,7	0,100	1205	567	-	454	420	400	370
1 x 400	23,60	2,0	1,9	35,0	0,0778	1660	665	-	512	474	450	417
1 x 500	26,50	2,2	2,0	38,6	0,0605	1940	765	-	578	535	505	468
1 x 630	30,20	2,4	2,2	43,1	0,0469	2460	880	-	646	598	580	537

N.B. I valori di portata di corrente sono riferiti a:
- n°3 conduttori attivi
- profondità di posa 0,8 m per i cavi interrati

N.B. K=1: resistività termica del terreno 1,0 K·m/W
K=1,5: resistività termica del terreno 1,5 K·m/W

Cavi per applicazioni in impianti fotovoltaici, con isolamento e guaina elastomerici, non propaganti la fiamma, senza alogeni e resistenti ai raggi UV.

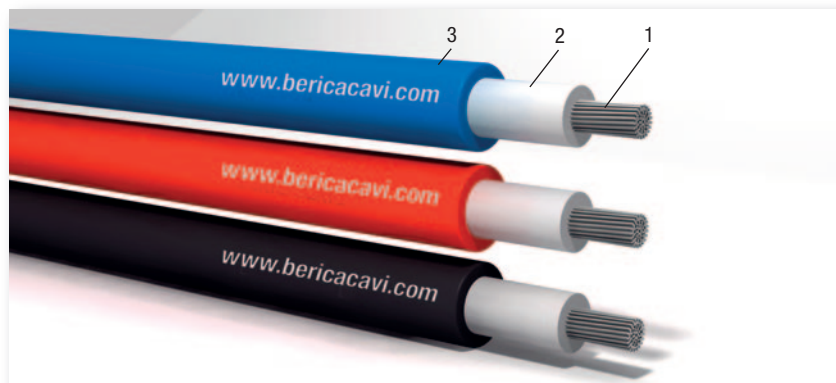

1. Conduttore
2. Isolante
3. Guaina

IMPIEGO: Adatti per l'interconnessione degli elementi degli impianti fotovoltaici, sono caratterizzati da: proprietà meccaniche ottimali in un intervallo di temperatura di esercizio da - 40 a + 90 °C, elevata resistenza all'abrasione, alla lacerazione, ai raggi UV, all'ozono, all'acqua, non propagazione della fiamma, basso sviluppo di fumi, assenza di alogeni, resistenza agli agenti atmosferici che ne permette una durata almeno pari alla vita dell'impianto fotovoltaico.

POSA: Per posa fissa all'esterno ed all'interno, senza protezione od entro tubazione in vista o incassate, o sistemi chiusi similari. E' ammessa la posa interrata diretta o indiretta.

ATTENZIONE: Utilizzare connettori stagnati di rame oppure in ottone stagnato.

CARATTERISTICHE	DESCRIZIONE	NORME
Conduttori:	alluminio	
Isolante:	elastomero reticolato atossico	CEI EN 50363
Guaina:	elastomero reticolato atossico	CEI EN 50363
Colore della guaina:	nero RAL 9005 - rosso RAL 3013 - blu RAL 5015	
Non propagante la fiamma:		CEI EN 60332-1-2
Senza alogeni:	(< 0,5 mg/g - 0,5%)	CEI EN 50267-2-1/2 - IEC 60754-1/2
Ridotta emissione di gas tossici:	(indice di tossicità < 2%)	CEI 20-37/4-0
Ridotta emissione di fumi:	(trasmissione > 60%)	CEI EN 61034-2
Resistente ai raggi UV:		HD 605
Resistente all'ozono:		CEI EN 50396
Comportamento a lungo termine:	(20000 h a 120 °C)	CEI EN 60216
Durata prevista:	25 anni	
Resistenza elettrica:		CEI EN 60228 (Tabella 9)
Portate di corrente:		CEI 20-21 - IEC 60287
Tensione nominale U _o /U:	0,6/1 kVac 0,9/1,5 kVcc	
Tensione massima:	1,2 kVac 1,8 kVcc	
Tensione di prova:	6,5 kVac 15 kVcc	
Temperatura max d'esercizio:	90 °C	
Temperatura di corto circuito:	250 °C	
Temperatura min di posa:	-25 °C	
Raggio di curvatura:	Ø x 6	
Marcatura:	BERICA CAVI S.P.A. ITALY SOLAR CABLE ALL 1500 Vcc PV1-F IEC 60332-1-2 CE Formazione AI (Formazione Cu)	
	Anno/Lotto 00000 m	

Cavi per applicazioni in impianti fotovoltaici, con isolamento e guaina elastomerici, non propaganti la fiamma, senza alogeni e resistenti ai raggi UV.

SOLAR CABLE ALLUMINIO				RESISTENZA ELETTRICA CONDUTTORE CORRISPONDENTE Ω/km	SOLAR CABLE RAME		
CODICE	TIPO N° x mm ²	Ø ESTERNO MEDIO mm	PESO MEDIO kg/km		TIPO N° x mm ²	Ø ESTERNO MEDIO mm	PESO MEDIO kg/km
B8801400A	1x4	5,7	35	8,21	1x2,5	5,1	47
B8801600A	1x6	6,4	45	5,09	1x4	5,7	63
B88011000A	1x10	7,4	62	3,39	1x6	6,5	86
B88011600A	1x16	9	92	1,95	1x10	7,9	125
B88012500A	1x25	10,9	135	1,24	1x16	9,2	188
B88014000A	1x40	12,8	189	0,8	1x25	11	291
B88015500A	1x55	14,6	245	0,57	1x35	12	383
B88018000A	1x80	16,9	335	0,39	1x50	14,3	552
B880111000A	1x110	19,1	435	0,28	1x70	16	712
B880114500A	1x145	22,4	600	0,21	1x95	18,1	925
B880119000A	1x190	25,4	765	0,16	1x120	20,7	1187
B880123000A	1x230	28,1	940	0,13	1x150	22,8	1476
B880127000A	1x270	30,4	1100	0,11	1x185	26	1785
B880137500A	1x375	34,8	1450	0,08	1x240	27	2390
B880142500A	1x425	37,1	1650	0,07	1x300	29,8	2440



Connettore porta maschio/femmina per applicazioni fotovoltaiche

F



M



DESCRIZIONE: Connettore volante porta maschio/femmina per applicazioni fotovoltaiche adatto per cavi in rame e alluminio con sezione conduttore da 1,5-2,5 mm², 4-6 mm² e 10 mm².

CARATTERISTICHE TECNICHE	DESCRIZIONE
PIN metallico:	rame stagnato
Resistenza di contatto:	Rc < 5mΩ
Diametro PIN:	3 mm
Tipo di PIN:	stampato
Guscio:	plastica (PPO)
Sezione cavi:	1,5 - 2,5 - 4 - 6 - 10 mm ²
Tensione massima applicabile:	1000 Vdc
Corrente massima applicabile:	25 A
Temperatura di esercizio:	-40 °C ÷ +85 °C
Grado di protezione:	IP67
Classe di infiammabilità:	UL94-V0
Tenuta all'acqua:	IP67 (IEC 60529)
Forza di inserzione:	≤ 50 N
Condizioni operative:	-40 °C ÷ +85 °C
Infiammabilità:	UL94V-0
Certificazioni:	TÜV per cod. IS13242 e IS23243

TIPO CONNETTORE	PER CONDUTTORE CON SEZIONE mm ²	CODICE
MASCHIO	1,5 - 2,5	IS13240
MASCHIO (TÜV)	4 - 6	IS13242
FEMMINA	1,5 - 2,5	IS23241
FEMMINA (TÜV)	4 - 6	IS23243
MASCHIO	10	IS14242
FEMMINA	10	IS24243

PINZATRICE



Pinza crimpatrice con corpo in acciaio, possiede manici di una lunghezza per la quale il serraggio manuale della pinza risulta molto più agevole. Semplice nell'utilizzo, è robusta, maneggevole, pratica, economica e, soprattutto, offre una buona qualità di crimpatura. È particolarmente adatta per il crimpaggio dei terminali sulla sezione di cavo da 10 mm².

INDICAZIONI DI UTILIZZO: Con la nuova crimpatrice è possibile regolare la pressione di crimpatura per un corretto e ottimale serraggio sui cavi tramite disco dentato. L'utensile è stato ideato per la realizzazione di crimpature eseguibili sui cavi fotovoltaici e trefoli intrecciati.

DIMENSIONI: Lunghezza: 260 mm, Spessore: 18 mm, Larghezza: 75 mm, Peso: 650 gr.

Scomparti MT
Cabina consegna
(Transfer Switch Station)

Application

Types



Switchgear type 8DJH 36

8DJH 36 switchgear is a factory-assembled, type-tested, metal-enclosed, metal-clad, SF₆-insulated switchgear for single-busbar applications for indoor installation.

8DJH 36 switchgear is used in public and industrial energy systems of the secondary distribution level, e.g. in

- Local ring-main units, customer transfer substations and switching substations of power supply and public utilities
- Wind power plants and solar plants, hydroelectric power stations
- Water and liquid waste processing systems
- Airports, train stations, underground stations
- High-rise buildings.

Electrical data (maximum values) and dimensions

Rated voltage	kV	36
Rated frequency	Hz	50/60
Rated short-duration power-frequency withstand voltage	kV	70
Rated lightning impulse withstand voltage	kV	170
Rated peak withstand current	kA	50/52
Rated short-circuit making current	kA	50/52
Rated short-time withstand current 3 s	kA	20
Rated normal current of the busbar	A	630
Rated normal current of the feeders	A	200/630
Width		
– Ring-main feeder	mm	430
– Transformer feeder	mm	500
Depth		
– without pressure relief duct	mm	920
– with pressure relief duct	mm	1035
Height		
– Standard	mm	1600
– With low-voltage compartment	mm	1800/2000/2200

Requirements

Features

Environmental independence

Hermetically tight, welded switchgear vessels made of stainless steel as well as single-pole solid insulation make the parts of the primary circuit under high voltage of 8DJH 36 switchgear

- Insensitive to certain aggressive ambient conditions, such as:
 - Saline air
 - Humidity
 - Dust
 - Condensation
- Tight to ingress of foreign objects, such as:
 - Dust
 - Pollution
 - Small animals
 - Humidity.

Compact design

Thanks to the use of SF₆ insulation, compact dimensions are possible.

Thus:

- Existing switchgear rooms and substation rooms can be used effectively
- New constructions cost little
- Costly city-area space is saved.

Maintenance-free design

Switchgear vessels designed as sealed pressure systems, maintenance-free switching devices and enclosed cable plugs ensure:

- Maximum supply reliability
- Personnel safety
- Sealed-for-life design according to IEC 62271-200 (sealed pressure system)
- Installation, operation, extension and replacement without SF₆ gas work
- Reduced operating costs
- Cost-efficient investment
- No maintenance cycles.

Innovation

The use of digital secondary systems and combined protection and control devices ensures:

- Clear integration in process control systems
- Flexible and highly simplified adaptation to new system conditions and thus to cost-efficient operation.

Service life

Under normal operating conditions, the expected service life of gas-insulated switchgear 8DJH 36 is at least 35 years, probably 40 to 50 years, taking the tightness of the hermetically welded switchgear vessel into account. The service life is limited by the maximum number of operating cycles of the switchgear devices installed:

- For three-position disconnectors and earthing switches, according to the endurance class defined in IEC 62271-102
- For three-position switch-disconnectors and earthing switches, according to the endurance class defined in IEC 62271-103.

Safety

Personal safety

- Safe-to-touch and hermetically sealed primary enclosure
- Standard degree of protection IP 65 for all high-voltage parts of the primary circuit, at least IP 2X for the switchgear enclosure according to IEC 60529 and VDE 0470-1
- Cable terminations and busbars are surrounded by earthed layers. All high-voltage parts including the cable terminations and busbars are metal-enclosed
- Operating mechanisms and auxiliary switches safely accessible outside the primary enclosure (switchgear vessel)
- High resistance to internal arcs by logical mechanical interlocks and tested switchgear enclosure
- Panels tested for resistance to internal faults up to 20 kA
- Capacitive voltage detecting system to verify safe isolation from supply
- Due to the system design, operation is only possible with closed switchgear enclosure
- Logical mechanical interlocks prevent maloperation
- HV HRC fuses and cable sealing ends are only accessible when outgoing feeders are earthed
- Feeder earthing via make-proof earthing switches.

Security of operation

- Hermetically sealed primary enclosure independent of environmental effects (pollution, humidity and small animals)
- Maintenance-free in an indoor environment (IEC 62271-1 and VDE 0671-1)
- Operating mechanisms of switching devices accessible outside the primary enclosure (switchgear vessel)
- Current transformers as ring-core current transformers mounted outside the SF₆ switchgear vessel
- Complete switchgear interlocking system with logical mechanical interlocks
- Welded switchgear vessels, sealed for life
- Minimum fire load
- Type and routine-tested
- Standardized and manufactured using numerically controlled machines
- Quality assurance in accordance with DIN EN ISO 9001
- More than 500,000 switchgear panels of Siemens in operation worldwide for many years.

Reliability

- Type and routine-tested
- Standardized and manufactured using numerically controlled machines
- Quality assurance in accordance with DIN EN ISO 9001
- More than 500,000 switchgear panels of Siemens in operation worldwide for many years.

General

- Three-pole primary enclosure, metal-enclosed
- Welded switchgear vessel, made of stainless steel, with welded-in bushings for electrical connections and mechanical components
- Insulating gas SF₆
- Maintenance-free components under normal ambient conditions according to IEC 62271-1 and VDE 0671-1
- Three-position switch-disconnector with load-break function and make-proof earthing function
- Cable connection with outside-cone plug-in system
 - In ring-main and transformer feeders with bolted contact (M16)
 - In transformer feeders optionally with plug-in contact
- Wall-standing or free-standing arrangement
- Cable connection access from front
- Installation and extension of existing switchgear at both ends without gas work and without modification of existing panels
- Pressure relief downwards, optionally to the rear/upwards, or via pressure relief duct and optionally with pressure absorber systems upwards.

Interlocks

- According to IEC 62271-200 and VDE 0671-200
- Logical mechanical interlocks prevent maloperation
- Logical mechanical interlocks and the constructive features of the three-position switches prevent maloperation as well as access to the cable connection of the feeders and HV HRC fuses under voltage
- Impermissible and undesired operations can be prevented by means of locking devices on the switching devices
- A detailed description of all interlocking options is available on page 24.

Modular design

- Individual panels and panel blocks can be lined up and extended at will – without gas work on site
- Low-voltage compartment available in 3 overall heights, wiring to the panel via plug connectors.

Instrument transformers

- Current transformers not subjected to dielectric stress
- Easy replacement of current transformers designed as ring-core transformers.

Secondary systems

- Customary protection, measuring and control equipment
- Option: Numerical multifunction protection relay with integrated protection, control, communication, operating and monitoring functions
- Can be integrated in process control systems.

Technical Data

Electrical data of the switchgear, classification

Rated insulation level	Rated voltage U_r	kV	36
	Rated short-duration power-frequency withstand voltage U_d		
	– phase-to-phase, phase-to-earth, open contact gap	kV	70
	– across the isolating distance	kV	80
	Rated lightning impulse withstand voltage U_p		
	– phase-to-phase, phase-to-earth, open contact gap	kV	170
	– across the isolating distance	kV	195
Rated frequency f_r		Hz	50/60
Rated normal current I_r (**)	for ring-main feeders	A	630
	for busbar	A	630
	for transformer feeders	A	200 ¹⁾
50 Hz	Rated short-time withstand current I_k	for switchgear with $t_k = 3$ s	up to kA 20
	Rated peak withstand current I_p		up to kA 50
	Rated short-circuit making current I_{ma}	for ring-main feeders	up to kA
for transformer feeders		up to kA	50
60 Hz	Rated short-time withstand current I_k	for switchgear with $t_k = 3$ s	up to kA 20
	Rated peak withstand current I_p		up to kA 52
	Rated short-circuit making current I_{ma}	for ring-main feeders	up to kA
for transformer feeders		up to kA	52
Filling pressure (pressure values at 20 °C)	Rated filling level p_{re} (absolute)	kPa	150
	Minimum functional level p_{re} (absolute)	kPa	130
Ambient air temperature T	without secondary equipment	°C	–25 to +55
	with secondary equipment	°C	–5 / –25 ²⁾ to +55
	for storage / transport including secondary systems	°C	–40 to +70 °C
Degree of protection	for gas-filled switchgear vessel		IP65
	for switchgear enclosure		IP2X/IP3X *)
	for low-voltage compartment		IP3X/IP4X *)

8DJH36 switchgear is classified according to IEC/EN 62271-200/ VDE 0671-200.

Design and construction

Partition class	PM (partition of metal)
Loss of service continuity category for panels or panel blocks	
– With HV HRC fuses (T)	LSC 2
– Without HV HRC fuses (R)	LSC 2
Accessibility to compartments (enclosure)	
– Busbar compartment	– Non accessible
– Switching-device compartment	– Non accessible
– Low-voltage compartment (option)	– Tool-based
– Cable compartment for panels or panel blocks	
– With HV HRC fuses (T)	– Interlock-controlled
– Without HV HRC fuses (R)	– Interlock-controlled

Internal arc classification (option)

Designation of the internal arc classification IAC	Rated voltage 36 kV
IAC class for	
– Wall-standing arrangement	IAC A FL
– Free-standing arrangement	IAC A FLR
Type of accessibility A	Switchgear in closed electrical service location, access “for authorized personnel only” (according to IEC 62271-200))
– F	Front
– L	Lateral
– R	Rear (for free-standing arrangement)
Arc test current	Up to 20 kA
Test duration	1 s

*) Design option

**) The rated normal currents apply to ambient air temperatures of max. 40 °C. The 24-hour mean value is max. 35 °C (according to IEC/EN 62271-1/VDE 0671-1)

1) Depending on the HV HRC fuse-link

2) Depending on the secondary equipment used

Three-position switch-disconnector

Switching capacity for general-purpose switches according to IEC/EN 62271-103/VDE 0671-103

	Rated voltage U_r	kV	36
Test duty TD _{load}	Rated mainly active load-breaking current I_{load}	100 operations I_{load} [I_1]	A 630
		20 operations 0.05 I_{load} [I_1]	A 31.5
Test duty TD _{loop}	Rated closed-loop breaking current I_{loop} [I_{2a}]	A	630
Test duty TD _{cc}	Rated cable-charging breaking current I_{cc} [I_{4a}]	A	50
Test duty TD _{lc}	Rated line-charging breaking current I_{lc} [I_{4b}]	A	50
Test duty TD _{ma}	Rated short-circuit making current I_{ma}	50 Hz	up to kA 50
		60 Hz	up to kA 52
Test duty TD _{ef1}	Rated earth-fault breaking current TD _{ef1} [I_{6a}]	A	150
Test duty TD _{ef2}	Rated cable-charging breaking current and line-charging breaking current under earth-fault conditions I_{ef2} [former I_{6b} ($\sqrt{3} \cdot I_{4a}$ or I_{4b})]	A	87
–	Cable-charging breaking current under earth-fault conditions with superimposed load current $I_{load} + \sqrt{3} \cdot I_{cc}$ [$I_1 + \sqrt{3} \cdot I_{4a}$]	A	630 + 87
Number of mechanical operating cycles/M-classification		n	1000/M1
Number of electrical operating cycles with I_{load} /Classification		n	100/E3
Number of short-circuit making operations with I_{ma} /Classification		n	5/E3
C-classification	For general-purpose switches (no restrikes, TD: I_{cc} , I_{lc})		C2

Classification for disconnectors according to IEC/EN 62271-102/VDE 0671-102

Number of mechanical operating cycles	n	1000
M-classification		M0

Switching capacity for make-proof earthing switch according to IEC/EN 62271-102/VDE 0671-102

Rated short-time withstand current I_k	50 Hz	up to kA	20
Rated short-circuit making current I_{ma}	50 Hz	up to kA	50
Rated short-time withstand current I_k	60 Hz	up to kA	20
Rated short-circuit making current I_{ma}	60 Hz	up to kA	52
Number of mechanical operating cycles		n	1000
Number of short-circuit making operations/Classification		n	5/E2

Switch-disconnector/fuse combination

Switch-disconnector/fuse combination

Rated voltage U_r	kV	36
Rated normal current I_r *)	A	200 ¹⁾

Switching capacity for switch-disconnector/fuse combination according to IEC/EN 62271-105/VDE 0671-105

Rated transfer current $I_{transfer}$	A	800
Maximum transformer rating	kVA	2500

Switching capacity for make-proof earthing switch, feeder side, in transformer feeder with HV HRC fuses

Rated short-time withstand current I_k with $t_k = 1s$		kA	2
Rated short-circuit making current I_{ma}	50 Hz	kA	5
	60 Hz	kA	5.2

*) The rated normal currents apply to ambient air temperatures of max. 40 °C.
The 24-hour mean value is max. 35 °C (according to IEC 62271-1/VDE 0671-1)

1) Depending on HV HRC fuse-link, depending on the let-through current of the HV HRC fuse-link

Product range

Individual panels and modules

Ring-main feeder

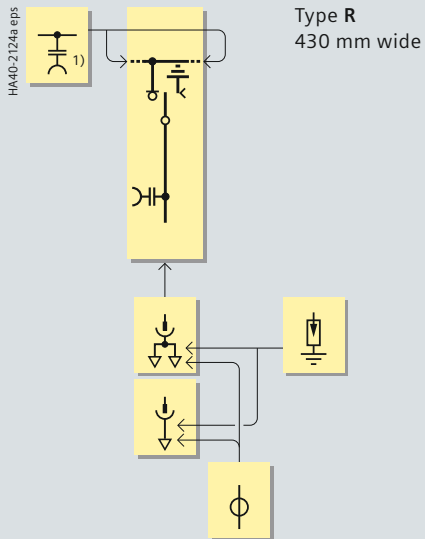

Transformer feeder

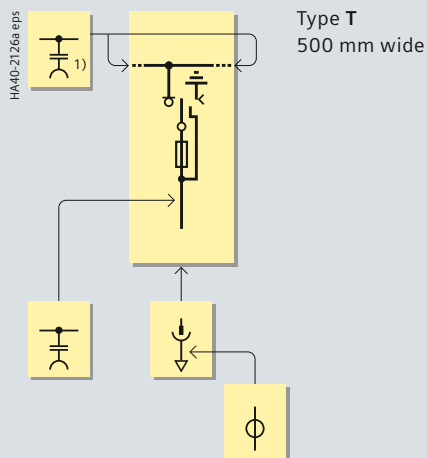

Three-position
switch-disconnector



Capacitive voltage
detecting system



HV HRC fuse



Cable-type
current transformer

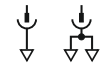

Cable connection
with outside cone
(not included in the
scope of supply)



Surge arrester

HA40-2123.eps

1) Only for end panel,
on the free con-
nection side of the
busbar

Ring-main feeder

Type R

Section

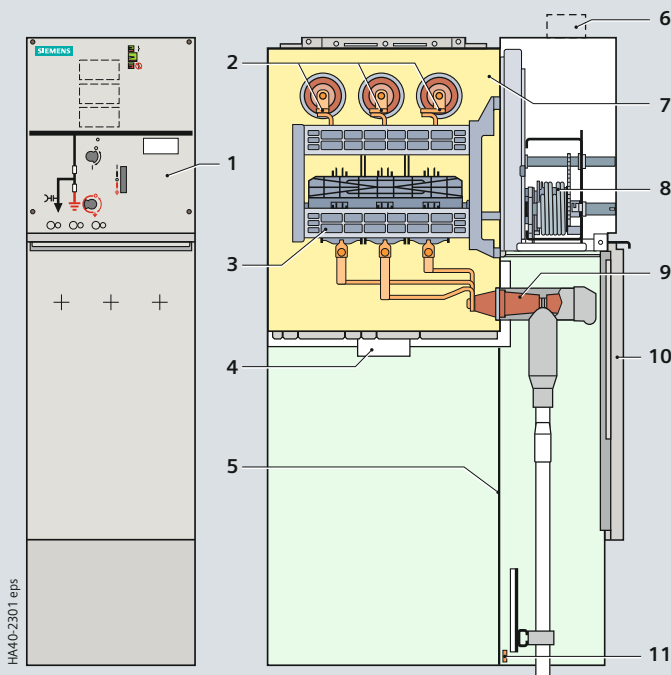

HA40-2301 eps

Transformer feeder

Type T

Section

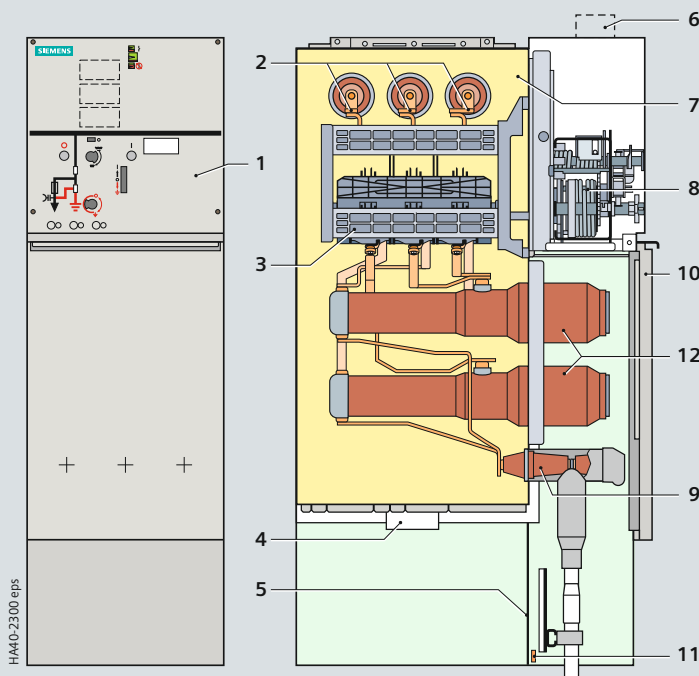

HA40-2300 eps

- 1 Control board (for details, see page 12)
- 2 Busbar arrangement
- 3 Three-position switch-disconnector
- 4 Pressure relief device
- 5 Partition plate between cable compartment and pressure relief compartment
- 6 Wiring duct, removable, for protection and/or bus wires
- 7 Switchgear vessel, filled with gas
- 8 Operating mechanism of switching device
- 9 Bushing for cable plug with bolted contact (M16)
- 10 Cable compartment cover
- 11 Earthing busbar with earthing connection
- 12 HV HRC fuse assembly

Design

Operation (examples)

The control boards are function-related. They integrate operation, mimic diagram and position indication. Furthermore, indicating, measuring and monitoring equipment as well as locking devices and local-remote switches are arranged according to the panel type and version. The ready-for-service indicator and rating plates are fitted in accordance with the panel blocks.

For the transformer feeder, the operating mechanism must be charged first; then, closing/opening is done through separate pushbuttons. The condition of the energy store is indicated.

All actuating openings are functionally interlocked against each other, and are optionally lockable. Separate operating levers for the disconnecting and earthing function are optionally available.

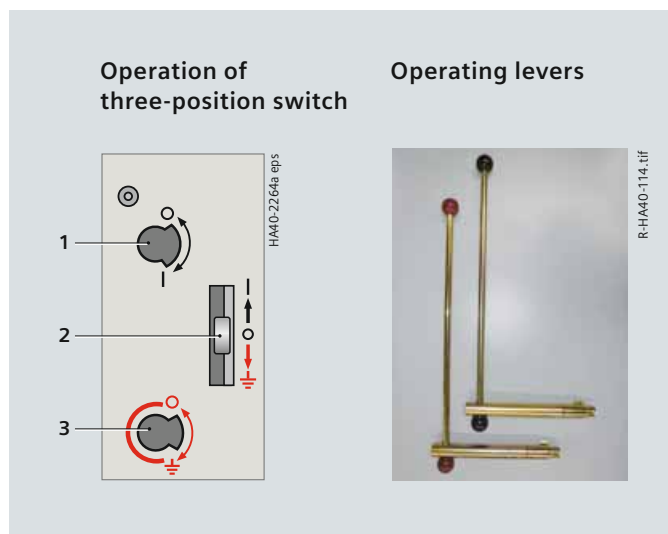

- 1 Manual operation of load-break function
- 2 Locking function (option for ring-main feeders)
- 3 Manual operation of earthing function
- 4 Panel designation label
- 5 Position indicator for switch-disconnector
- 6 Position indicator for earthing switch
- 7 Sockets of capacitive voltage detecting system
- 8 "Fuse tripped" indicator
- 9 ON pushbutton for transformer function
- 10 OFF pushbutton for transformer function
- 11 Manual spring charging
- 12 "Spring charged" indicator

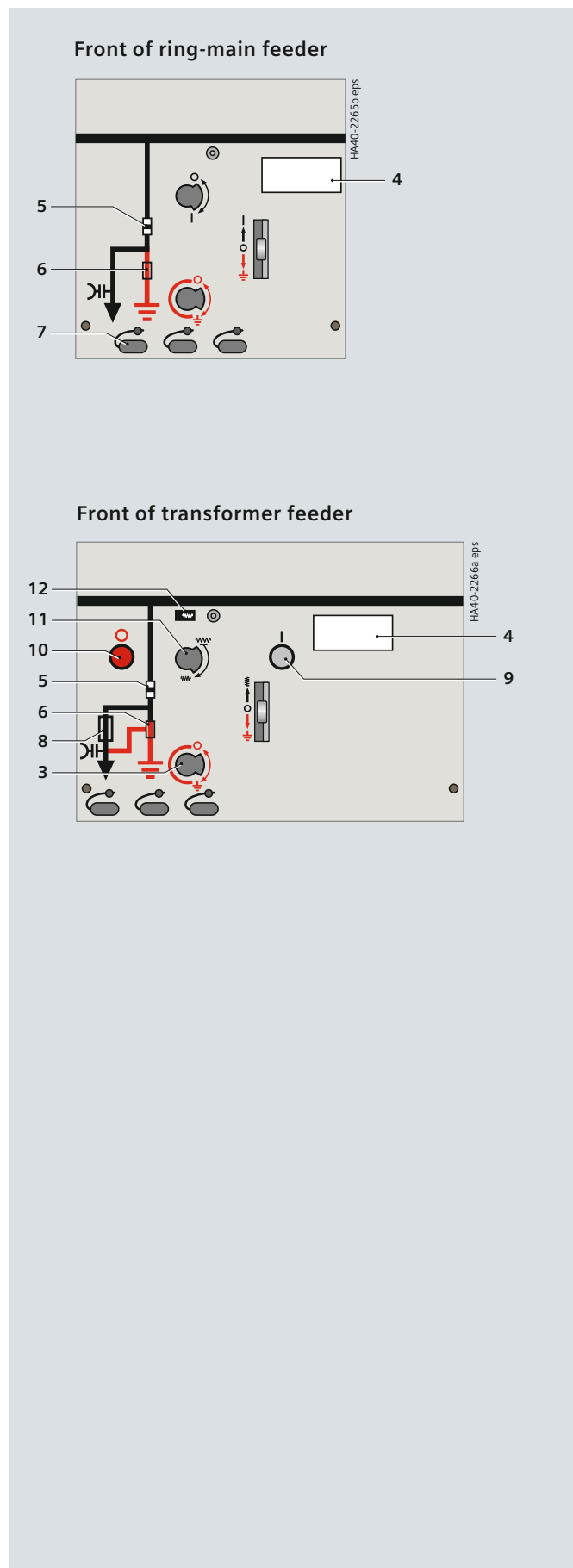

Features

- Switch positions: CLOSED – OPEN – EARTHED
- Switching functions as general-purpose switch-disconnector (class E3) according to
 - IEC/EN 62271-103/VDE 0671-103
 - IEC/EN 62271-102/VDE 0671-102
- Designed as a three-position switch with the functions
 - Switch-disconnector and
 - Make-proof earthing switch
- Operation via rotary bushing welded gas-tight into the front of the switchgear vessel
- Climate-independent contact in the gas-filled switchgear vessel
- Maintenance-free for indoor installation according to IEC/EN 62271-1/VDE 0671-1
- Individual secondary equipment.

Mode of operation

The operating shaft forms one unit together with the three contact blades. Due to the arrangement of the fixed contacts (earth – busbar), it is not necessary to interlock the CLOSE and EARTHING functions.

Closing operation

During the closing operation, the operating shaft with the moving contact blades changes from the “OPEN” to the “CLOSED” position.

The force of the spring-operated mechanism ensures a high operator-independent closing speed and a reliable connection of the main circuit.

Opening operation

During the opening operation, the arc is caused to rotate by the arc-suppression system. This rotation movement prevents the development of a fixed root.

The isolating distance in gas established after breaking fulfills the conditions applicable to isolating distances in accordance with

– IEC/EN 62271-102/VDE 0671-102

and

– IEC/EN 62271-1/VDE 0671-1.

Due to the arc rotation caused by the arc-suppression system, both load currents and minor no-load currents are safely interrupted.

Earthing operation

The EARTHING operation is implemented by changing from the “OPEN” to the “EARTHED” position.

Three-position switch-disconnector

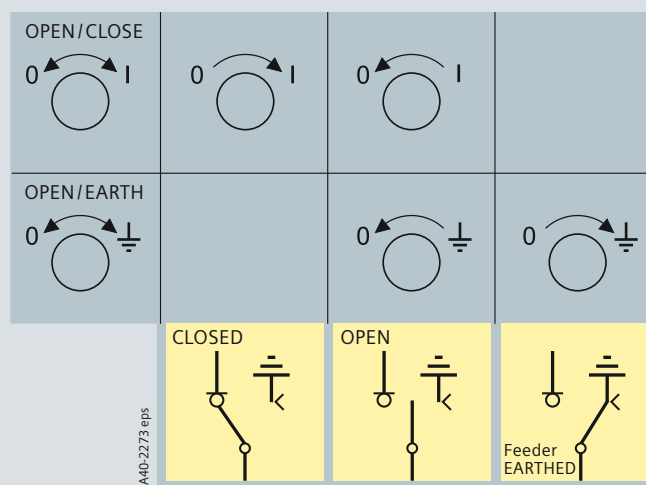
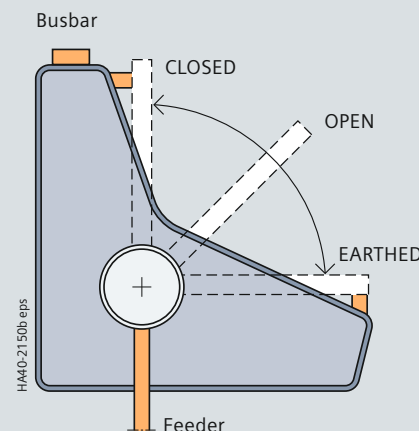

Cabina di trasformazione

(Transformer station)

Il trasformatore

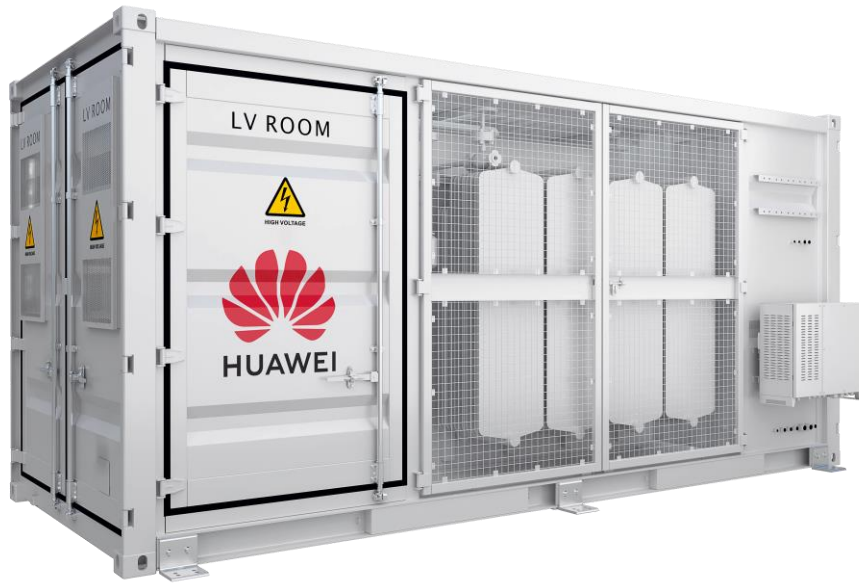

Simple

Prefabricated and pre-tested, no onsite internal cabling
Compact 20'HC container design for easy transportation



Efficiency

Eco-design Transformer Suitable for All
Lower Self-consumption for Higher Yields



Smart

Real-time monitoring of transformer, LV and MV switchgear
0.2% high precision of electricity parameters collection
Remote control of ACB and MV Circuit Breaker



Reliable

Robust design against harsh environments
Innovative cooling design, easy maintenance
Comprehensive tests from components, device to solutions

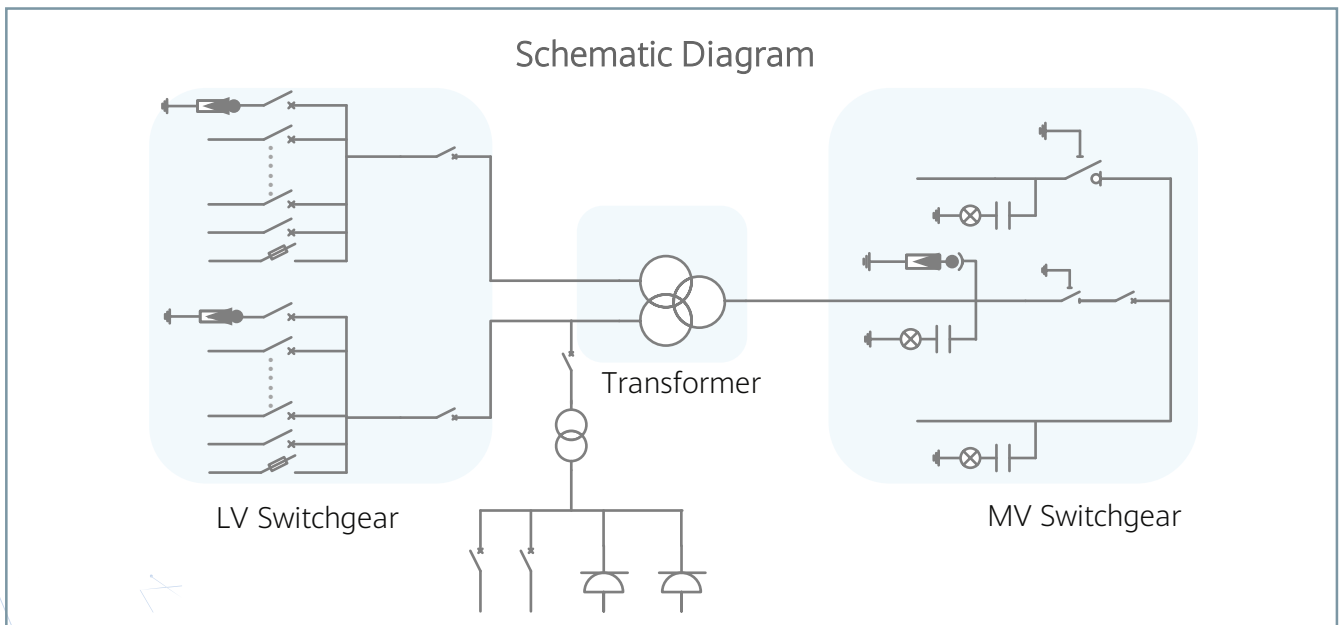

STS-6000K-H1, Ecodesign
Technical Specifications

Input						
Available Inverters	SUN2000-185KTL-H1					
AC Power	6,300 kVA @40°C / 5,400 kVA @50°C ¹					
Max. Inverters Quantity	36					
Rated Input Voltage	800 V					
Max. Input Current at Nominal Voltage	2 * 2428 A					
LV Panel Type	ACB (2500 A / 800 V / 3P, 2*1 pcs), MCCB (250 A / 800 V / 3P, 2*18 pcs)					
Output						
Rated Output Voltage	10 kV	22 kV	30 kV	33 kV	34.5 kV	35 kV
Frequency	50 Hz	50 Hz	50 Hz	50 Hz	60 Hz	50 Hz
Transformer Type	Oil-immersed, Conservator Type					
Tappings	± 2 x 2.5%					
Transformer Oil Type	Mineral Oil					
Transformer Vector Group	Dy11-y11					
Minimum Peak Efficiency Index	In accordance with EN 50588-1					
Transformer Load Losses	49.7 kW	49.7 kW	49.7 kW	49.7 kW	41 kW	49.7 kW
Transformer No-load Losses	4.8 kW	4.8 kW	4.8 kW	4.8 kW	5.8 kW	4.8 kW
Impedance	7.5% (0 ~ +10%) @6300 kVA					
MV Switchgear Type	SF6 Gas Insulated, 3 Feeders					
Auxiliary Transformer	5 kVA, Dyn11, Ratio Varies according to Customization					
Protection						
Protection Degree of MV & LV Room	IP 54					
Internal Arcing Fault MV Switchgear	IAC A 20 kA 1s					
LV SPD	Type I + II					
General						
Dimensions (W x H x D)	6,058 x 2,896 x 2,438 mm (20' HC Container)					
Weight	< 22 t					
Operating Temperature Range	-25°C ~ 60°C ² (-13°F ~ 140°F)					
Relative Humidity	0% ~ 95%					
Max. Operating Altitude	2000 m	2000 m	2000 m	2000 m	2500 m	2000 m
Applicable Standards	IEC 60076, IEC 62271-200, IEC 62271-202, EN 50588-1, IEC 61439-1					
Features						
Auxiliary Transformer(50 kVA, Dyn11)	Optional ³ , Ratio Varies according to Customization					
1.5 kVA UPS	Optional ³					
Updated to CVC or CCV MV Switchgear	Optional ³					
IMD	Optional ³					
STS Interlocking	Optional ³					

- 1 - More detailed AC power of STS, please refer to the de-rating curve.
 2 - When ambient temperature ≥55°C, awning shall be equipped for STS on site by customer.
 3 - Extra expense needed for optional features which standard product doesn't contain.

***Cabina di trasformazione
(Transformer station)
&
Cabina di smistamento***

2 Overview

2.1 Product Introduction

Function

The transformer station converts low-voltage AC power generated by the PV inverter into medium-voltage AC power and feeds the power into the power grid.

The transformer station integrates the ring main unit, transformer, low-voltage cabinet, and auxiliary power supply into a steel-structure container to provide a highly integrated power transformation and distribution solution for ground-based PV plants in medium-voltage grid-tied scenarios.

Features

Smart

- Detects the operating status of the ring main unit, transformer, and low-voltage cabinet in real time.
- Detects power parameters online, with the current and voltage detection accuracy up to 0.5.
- Supports the remote control of the general circuit breaker for the low-voltage cabinet and ring main unit as well as the remote query of the running information about the transformer station.

Simple

- Internal equipment has been prefabricated and installed.
- Compact 20-foot container structure that facilitates transportation and installation.

Reliable

- Solid and reliable structure design
- IP rating of medium-voltage/low-voltage rooms: IP54

Fast deployment

- Fast deployment can be implemented.
- Only low-voltage cables need to be routed in and medium-voltage cables need to be routed out onsite.

Network Application

The transformer station applies to the grid-tied systems in large PV plants. Typically, a grid-tied PV system consists of the PV string, SUN2000, AC combiner box/switch box, and the transformer station.

Figure 2-1 Network application

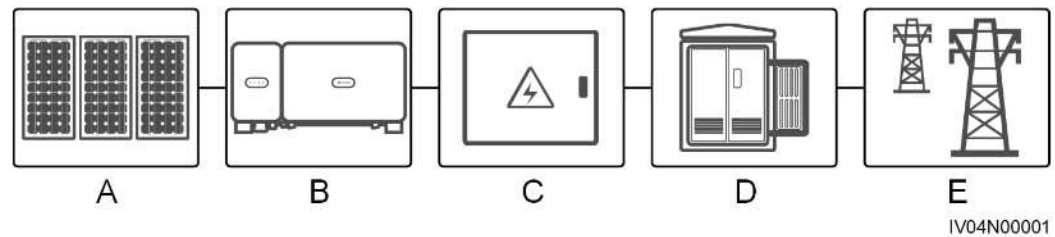

- (A) PV string (B) SUN2000 (C) AC combiner box/Switch box
(D) Transformer station (E) Power grid

2.2 Appearance

2.2.1 STS-2500K Appearance

Appearance

Figure 2-2 Appearance

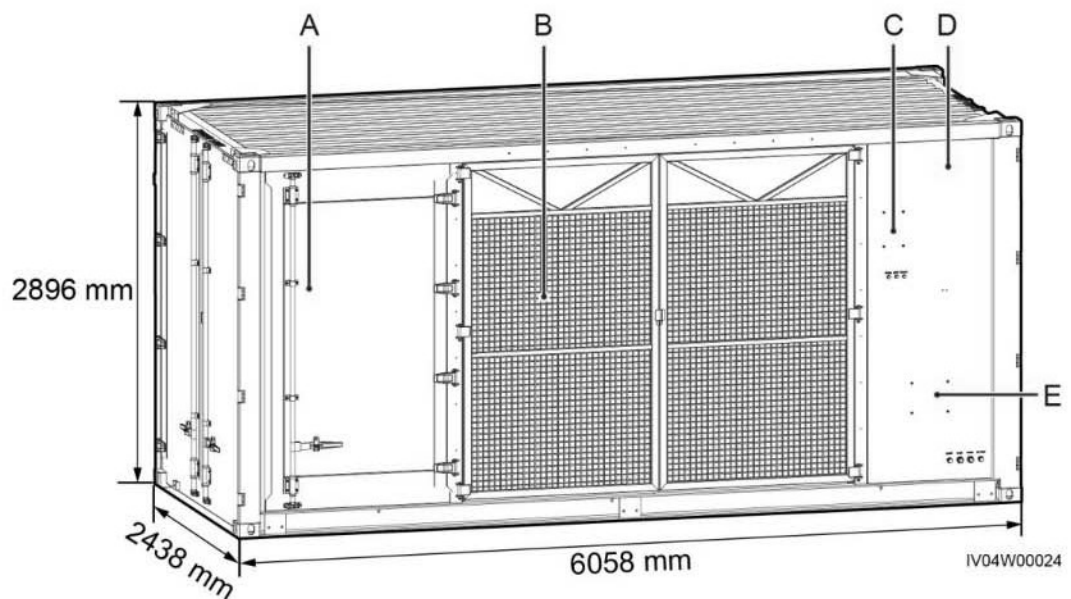

- (A) Low-voltage room (LV) (B) Transformer room (TR)
(C) Installation position for the distributed power (D) Medium-voltage room

system (MV)
(E) Installation position for the smart array controller

Layout

Figure 2-3 Layout

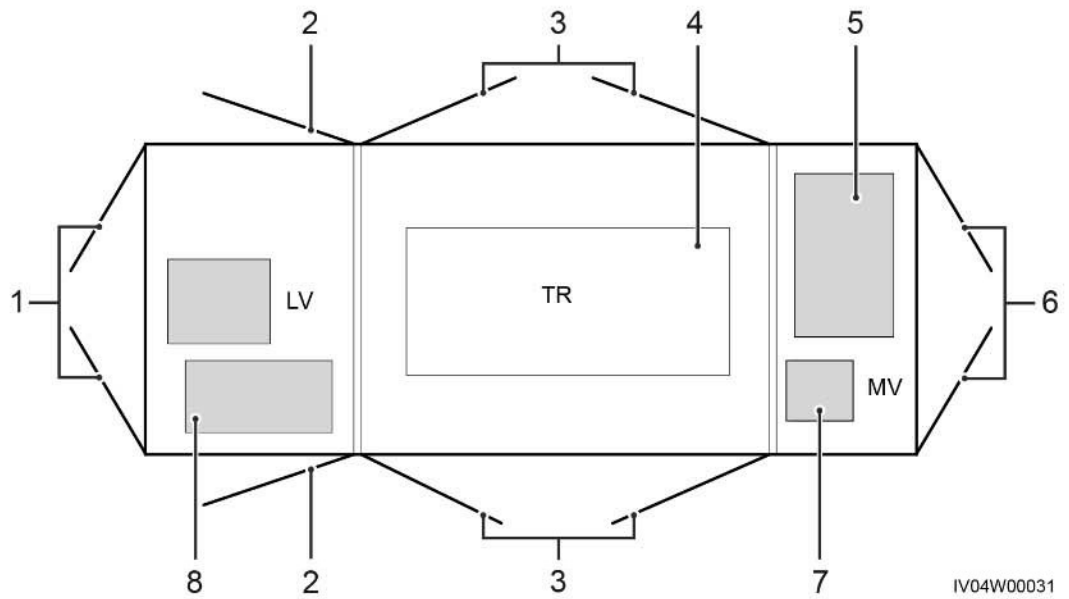

- | | | |
|----------------------------------|----------------------------------|--|
| (1) Low-voltage room double door | (2) Low-voltage room single door | (3) Transformer double-swing screen door |
| (4) Transformer | (5) Ring main unit | (6) Medium-voltage room double door |
| (7) Auxiliary transformer | (8) Low-voltage cabinet | |

Bottom View

Figure 2-4 Bottom view

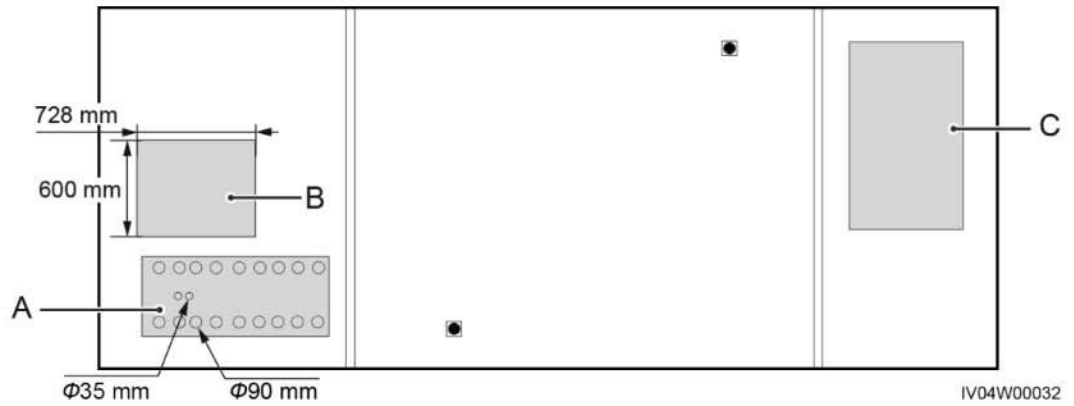

(A) AC input power cable hole

(B) Trench entry

(C) Pressure relief channel and cable hole (ring main unit)

Interior

Figure 2-5 Interior

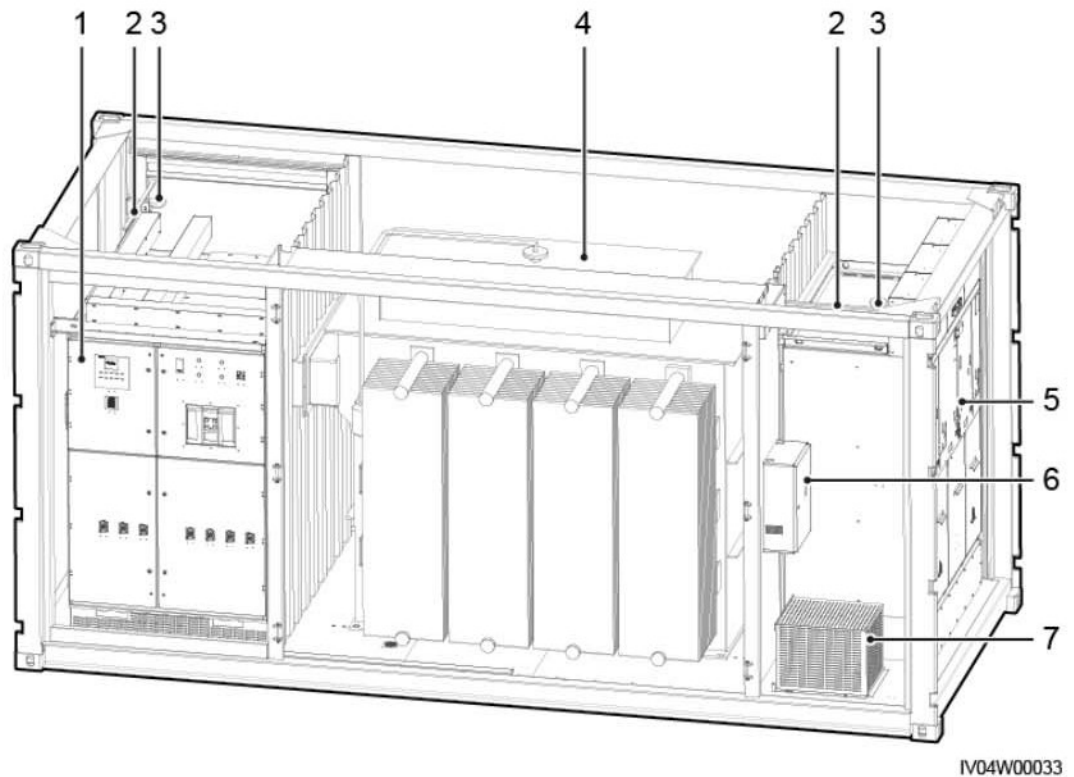

(1) Low-voltage cabinet

(2) Light

(3) Smoke sensor

(4) Transformer

- (5) Ring main unit
- (6) Power distribution box
- (7) Auxiliary transformer

2.2.2 STS-6000K Appearance

Appearance

Figure 2-6 Appearance

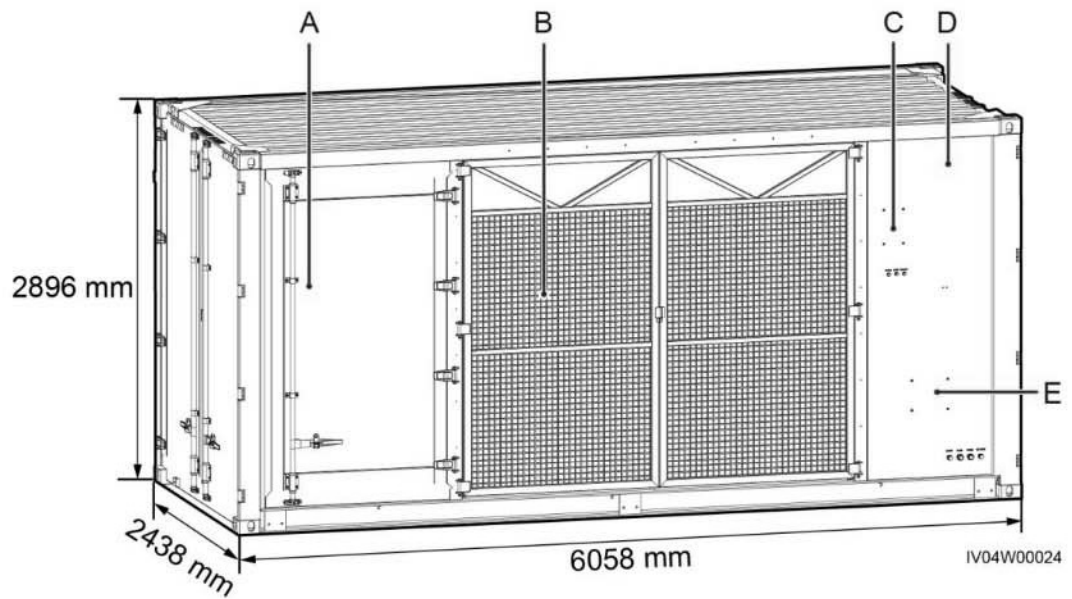

- (A) Low-voltage room (LV)
- (B) Transformer room (TR)
- (C) Installation position for the distributed power system
- (D) Medium-voltage room (MV)
- (E) Installation position for the smart array controller

Layout

Figure 2-7 Layout

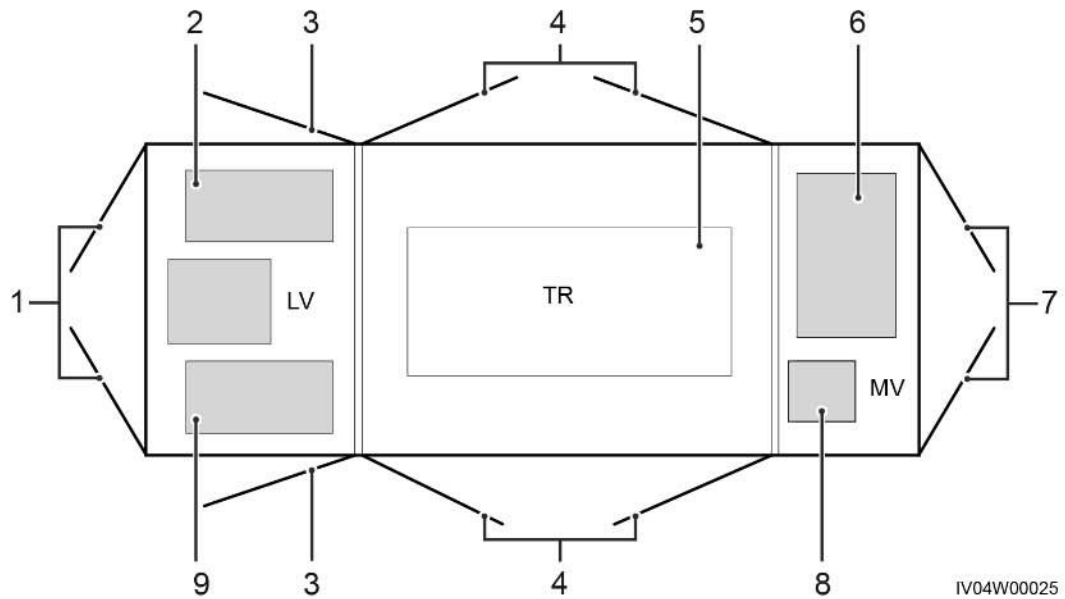

- | | | |
|--|---------------------------|----------------------------------|
| (1) Low-voltage room double door | (2) Low-voltage cabinet B | (3) Low-voltage room single door |
| (4) Transformer double-swing screen door | (5) Transformer | (6) Ring main unit |
| (7) Medium-voltage room double door | (8) Auxiliary transformer | (9) Low-voltage cabinet A |

Bottom View

Figure 2-8 Bottom view

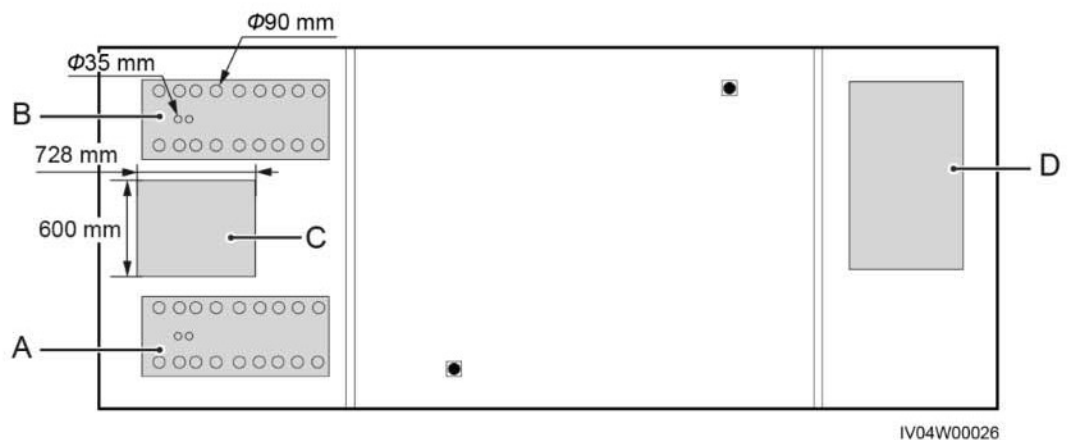

- | | |
|---|---|
| (A) AC input power cable hole (low-voltage cabinet A) | (B) AC input power cable hole (low-voltage cabinet B) |
|---|---|

(C) Trench entry

(D) Pressure relief channel and cable hole
(ring main unit)

Interior

Figure 2-9 Interior

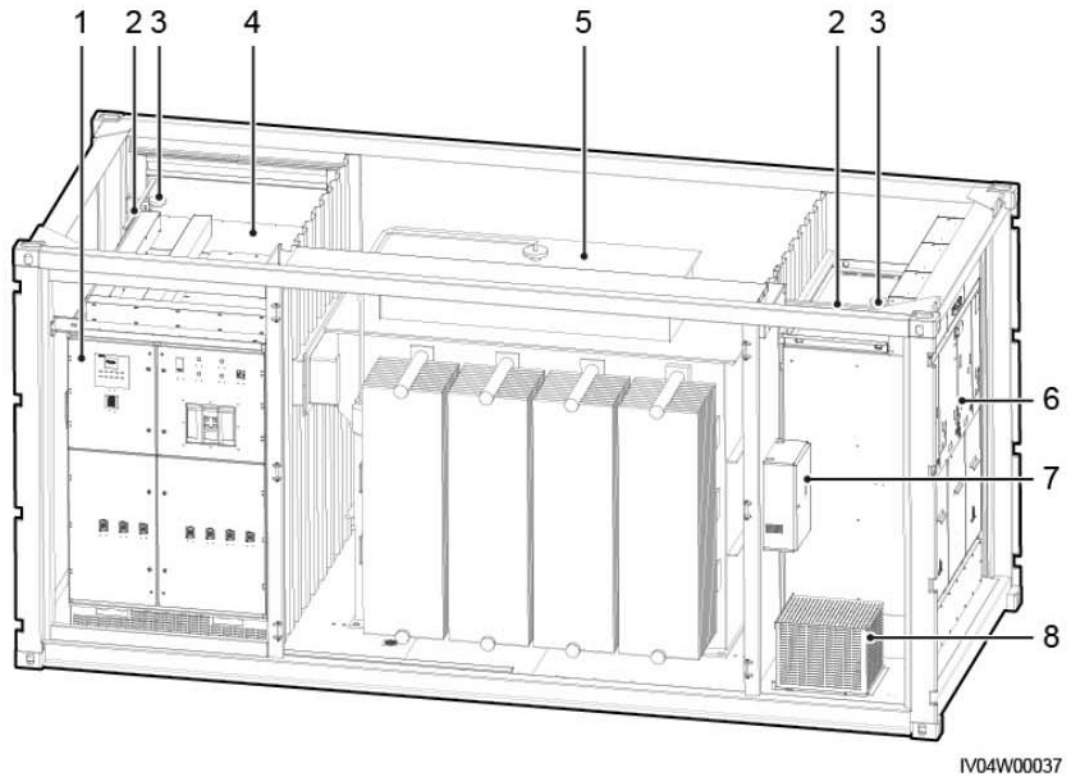

(1) Low-voltage
cabinet A

(2) Light

(3) Smoke sensor

(4) Low-voltage
cabinet B

(5) Transformer

(6) Ring main
unit

(7) Power distribution
box

(8) Auxiliary
transformer

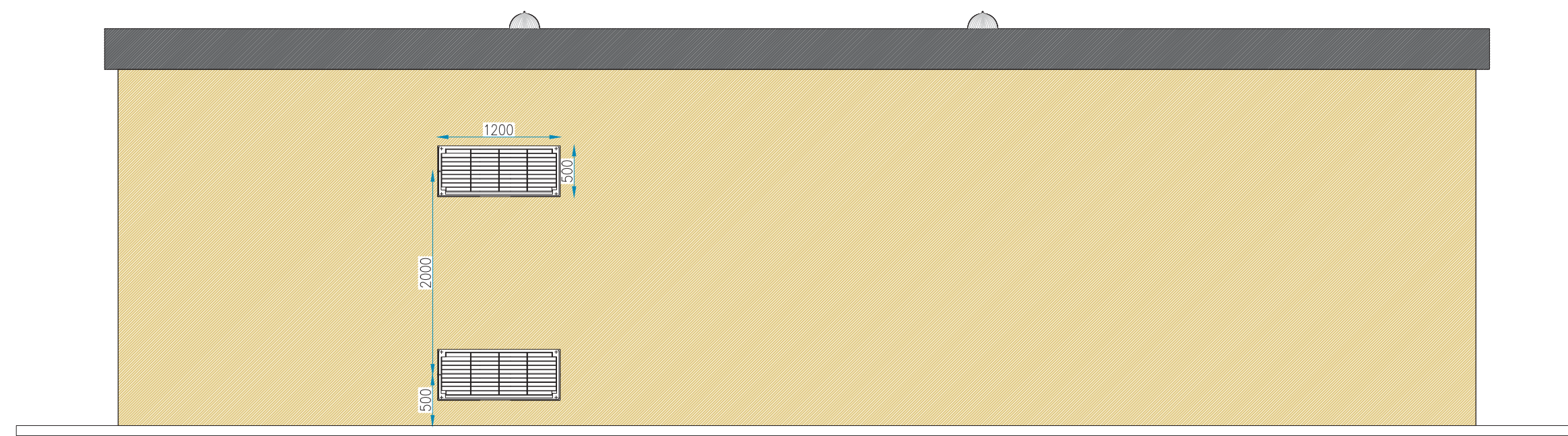

PROSPETTO POSTERIORE



PROSPETTO SX

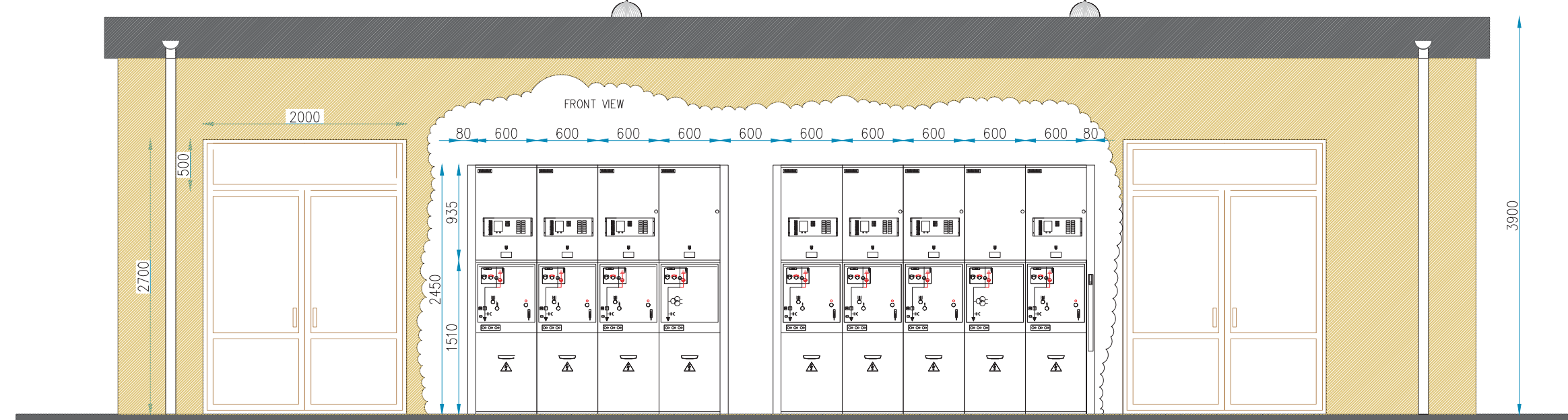

PROSPETTO ANTERIORE

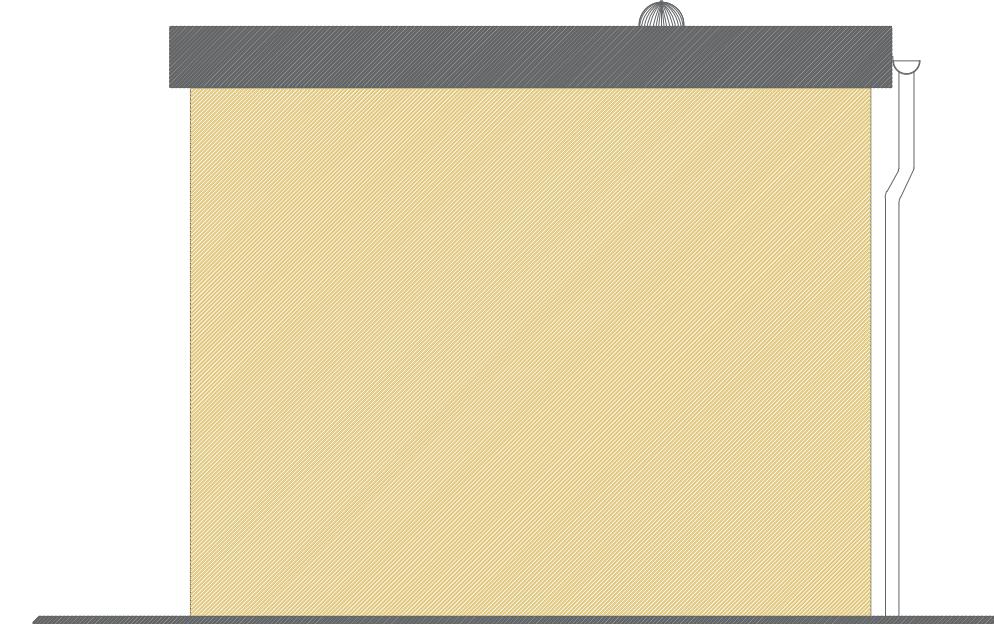

PROSPETTO DX

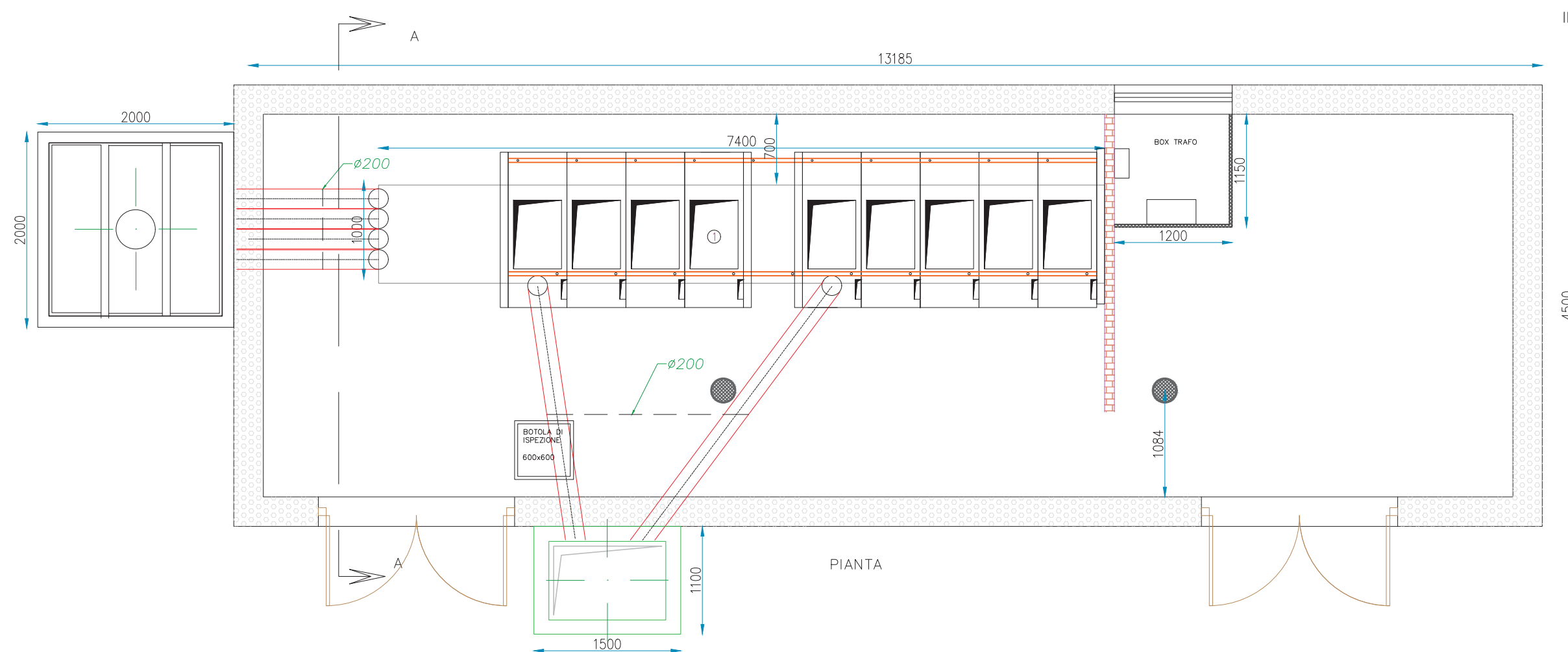

PIANTA

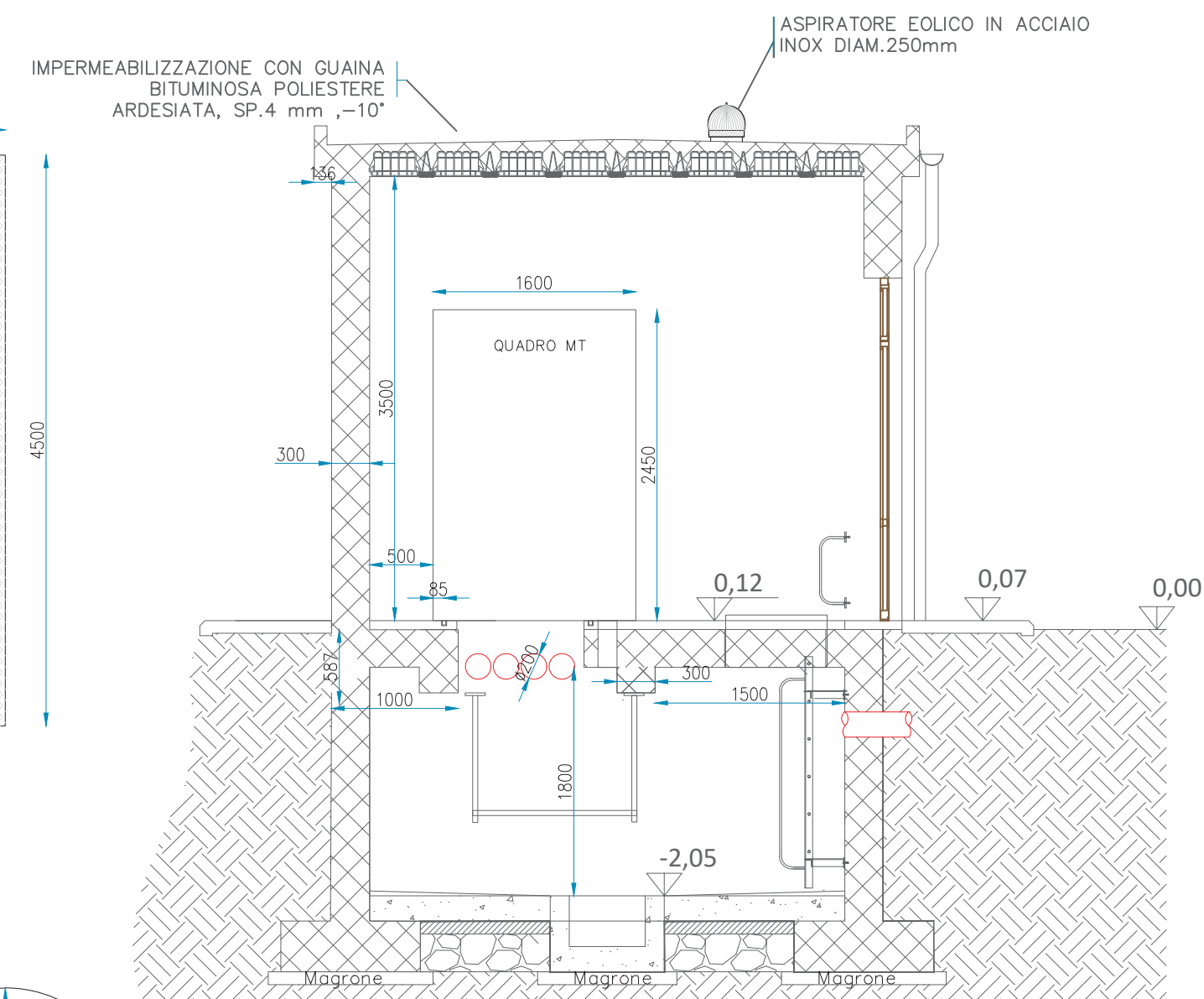

SEZIONE A-A

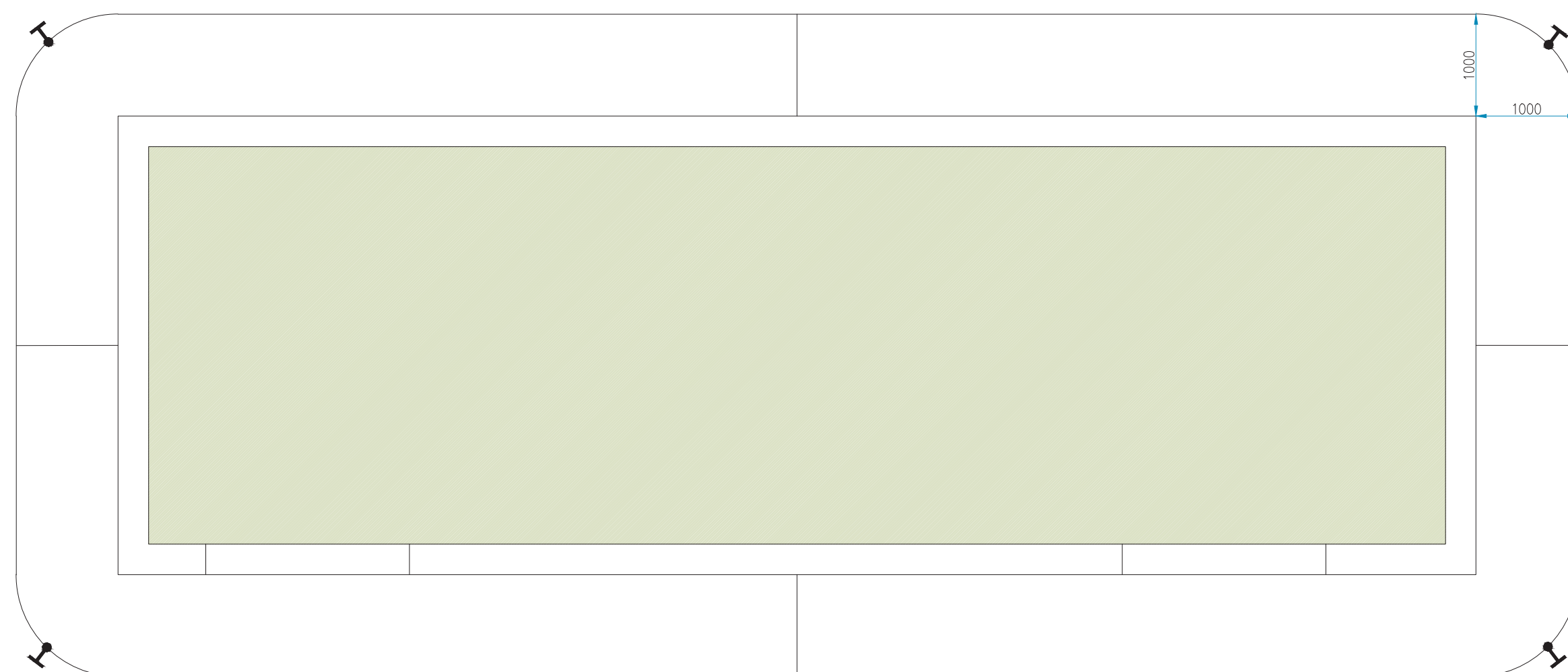

IMPIANTO DI MESSA A TERRA

PARTICOLARE COLLEGAMENTO DI TERRA

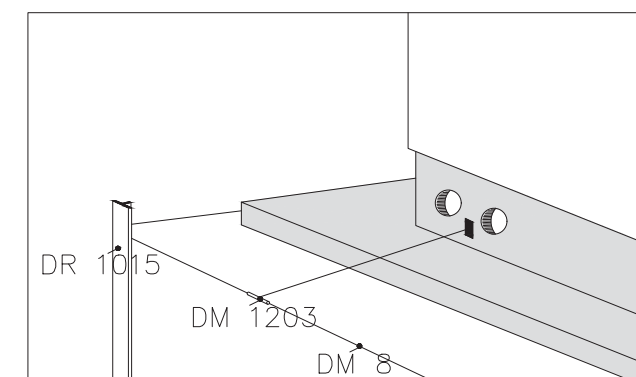

SIGLA	DESCRIZIONE
DM 8	Conduttore o corda di rame ϕ 7,56 sez 35 mm ²
DM1263	Morsetto bifilare a compressione
DR1015	Poiletto di terra in profilato di acciaio
DR1020	Capocorda a compressione diritto per corda di rame ϕ 7,56 con attacco per poiletto di ferro

CABINA DI SMISTAMENTO