

TG 2074/6

(SCARICATORE - lato portale attraversamento strada)

PIANTA

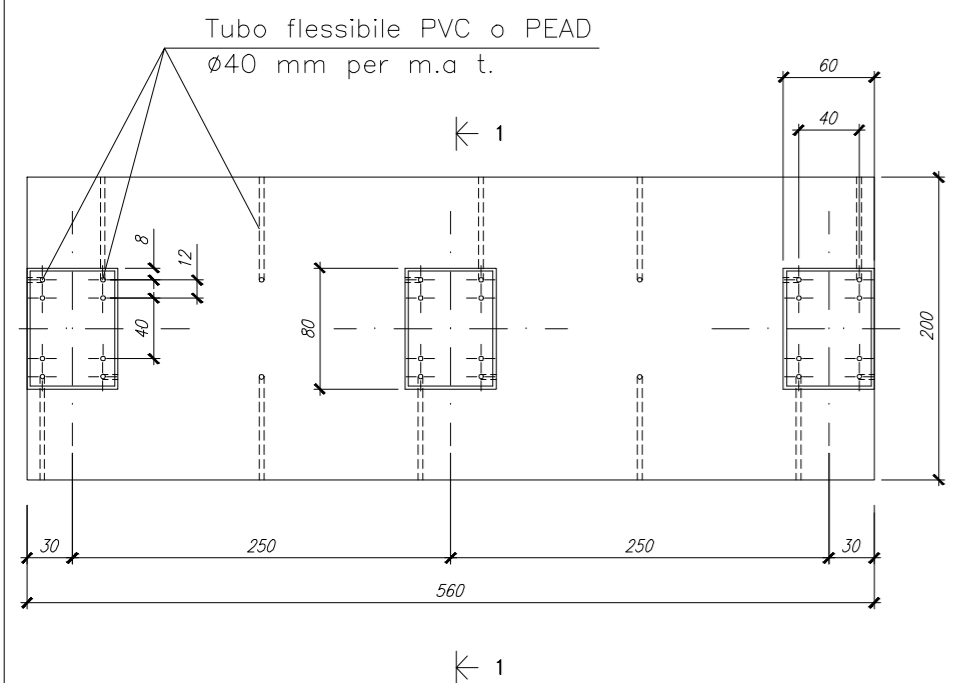

SEZIONE 1-1

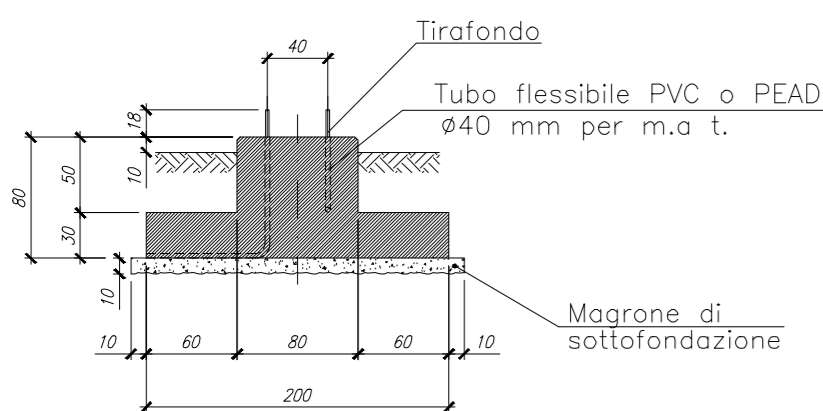

TG 2074/7

(PORTALE SBARRE)

PIANTA

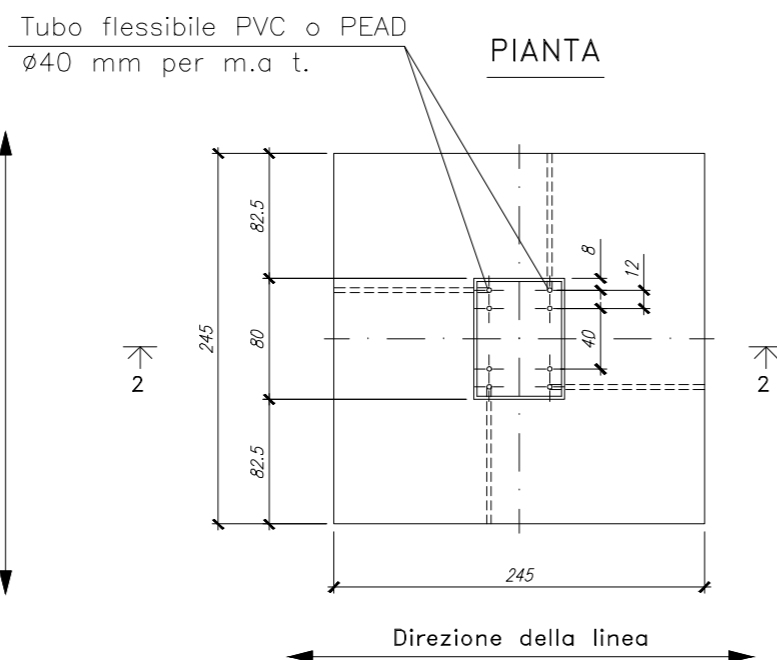

SEZIONE 2-2

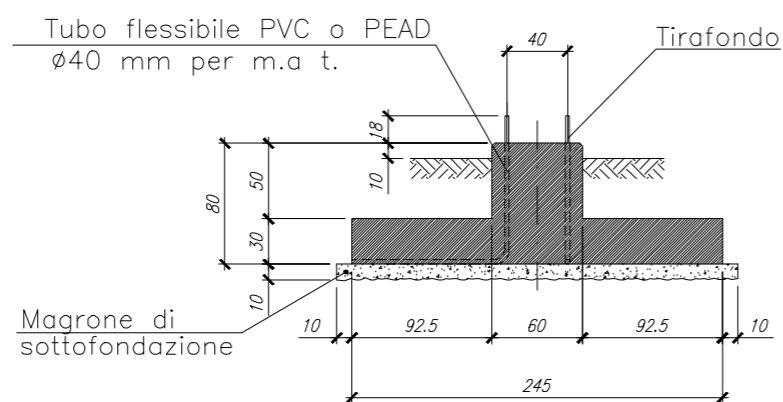

TG 2074/8

(PORTALE CON LAME DI TERRA)

PIANTA

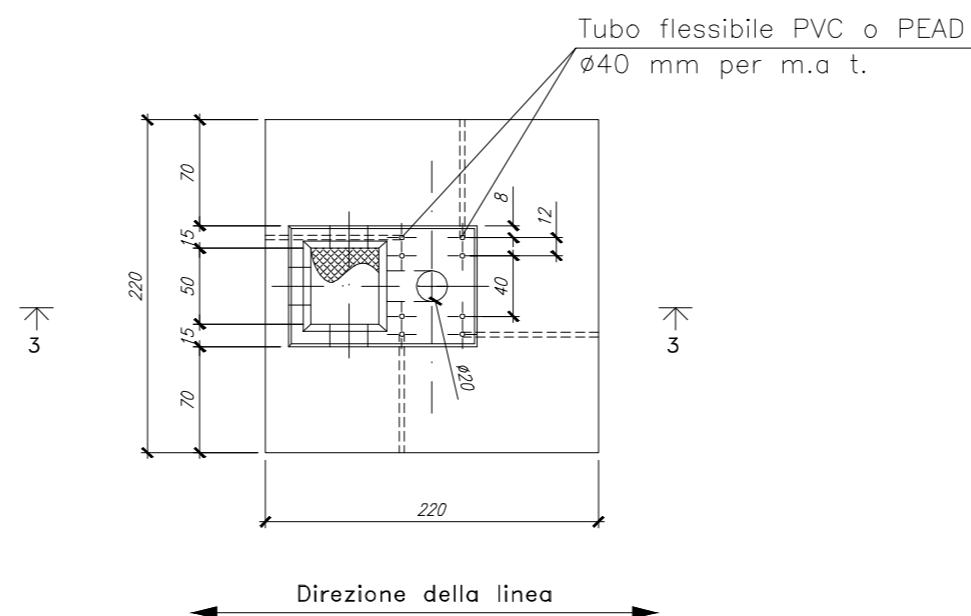

SEZIONE 3-3

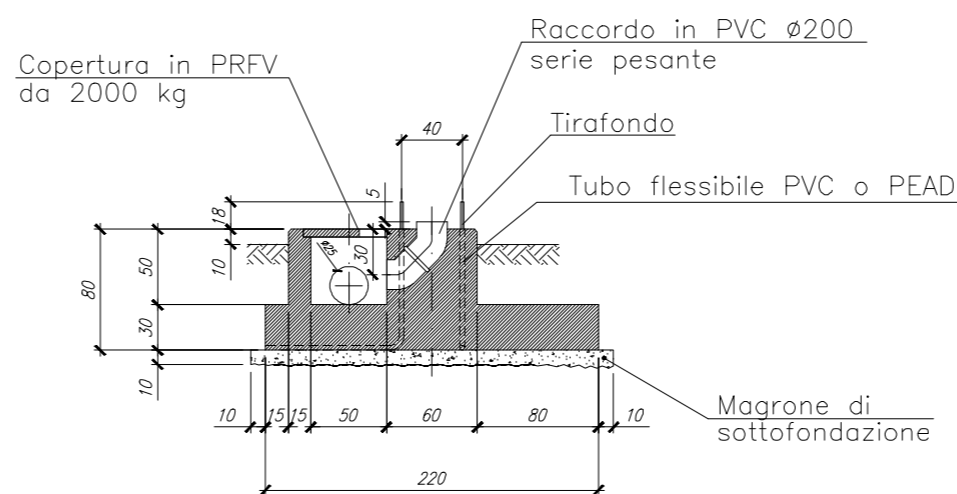

TG 2074/9

(TV + SCARICATORE DI LINEA - base tripla)

PIANTA

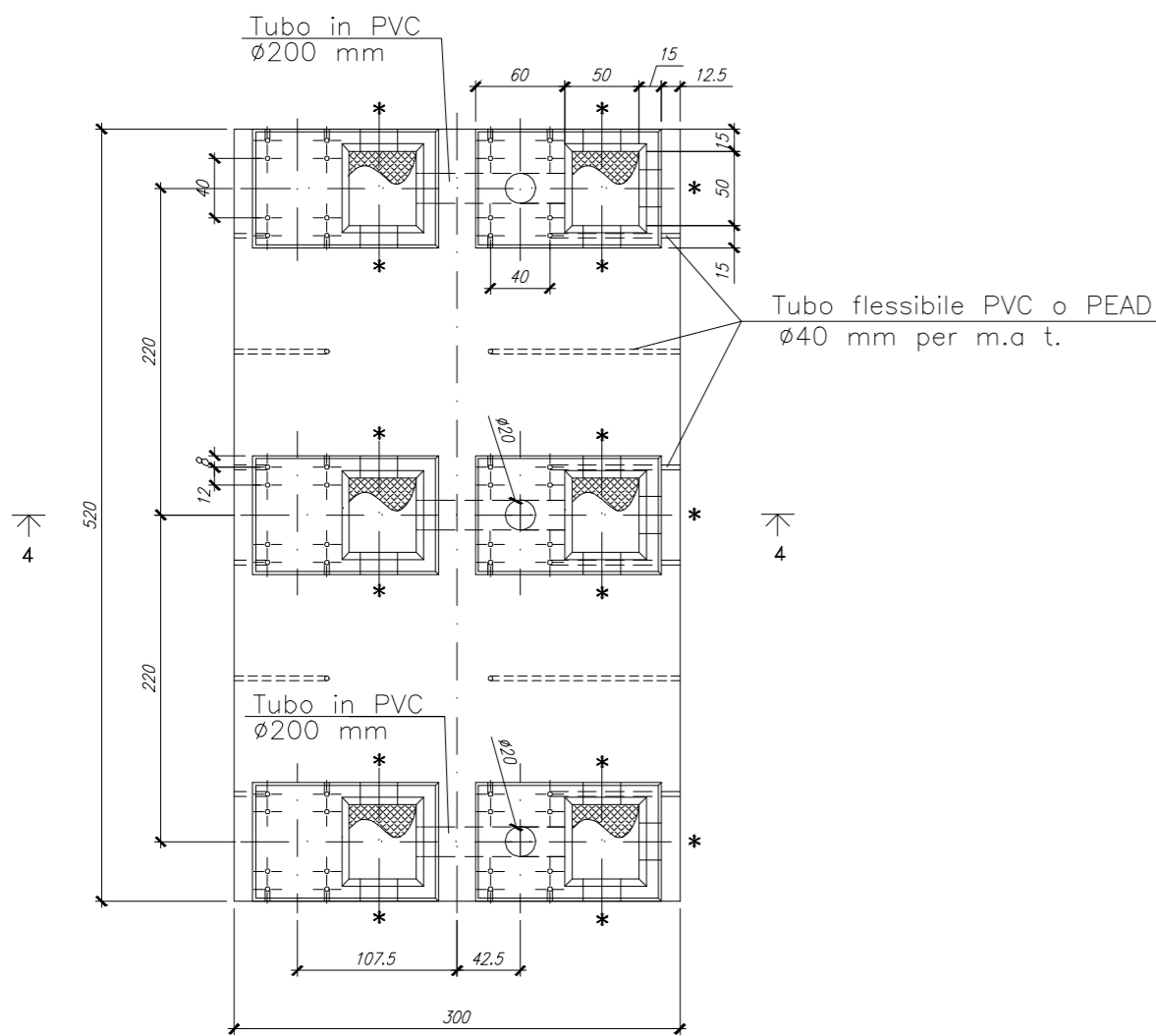

SEZIONE 4-4

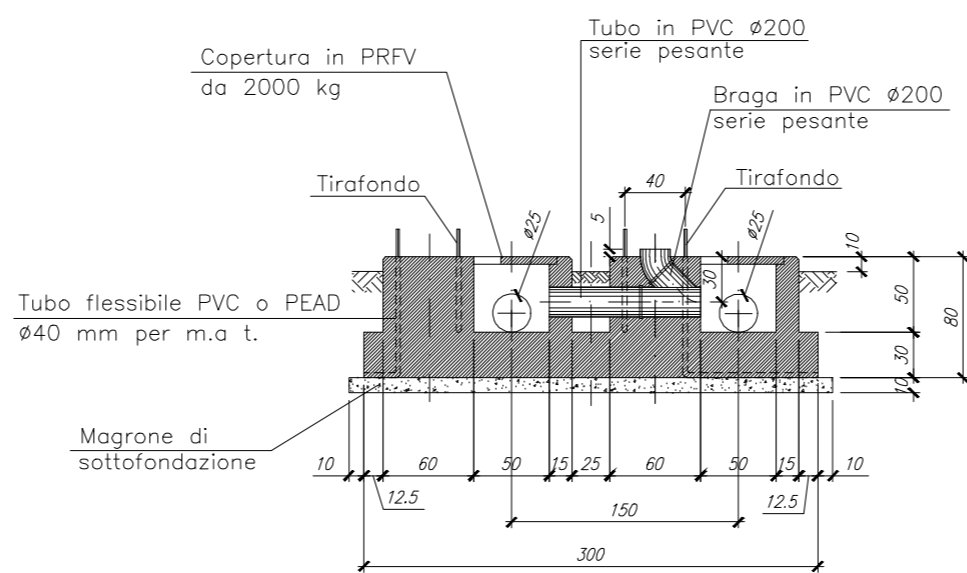

COMUNE DI BRINDISI

(Provincia di Brindisi)

PTO opere Rete elettrica Nazionale per connessione impianti fotovoltaici in Loc. C.da Vaccaro, C.da Baroni e C.da Casignano

Codifica

PFBR-D-T26

Descrizione

Fondazione Sottostazione Elettrica RTN APPARECCHIATURE UNIPOLARI TG2074 /6 /7 /8 /9

Proponente



GUARINI S.R.L.
Galleria Vintler 17 - IT 39100 Bolzano (BZ)
Tel +39 02 997 493 83
guarini.srl@pec.it



BARONI S.R.L.
Galleria Vintler 17 - IT 39100 Bolzano (BZ)
Tel +39 3409196155
www.solar-konzept.de
info@solar-konzept.it



DEPALMA S.R.L.
Galleria Vintler 17 - IT 39100 Bolzano (BZ)
Tel +39 0299749383
pec: depalma.srl@pec.it

Progettazione opere di fondazione sottostazione RTN



INSE S.R.L.
Via San Giacomo dei Capri, 38
80128 - NAPOLI
Tel. 081 5797998 - e-mail: inse.srl@pec.it



REVISIONI					
N.	DATA	DESCRIZIONE	ELABORATO	VERIFICATO	APPROVATO
02	29.01.2020	Integrazioni a seguito nota Reg. Puglia n.GR_GUA191220	N. GALDIERO	F. DI MASO	GUARINI SRL - DEPALMA SRL - BARONI SRL
TIPOLOGIA DELL'ELABORATO		FORMATO	SCALA	FOGLIO	
TAVOLA GRAFICA		A1	1 : 50	1 / 1	