

PROSPETTO D - D scala 1:100

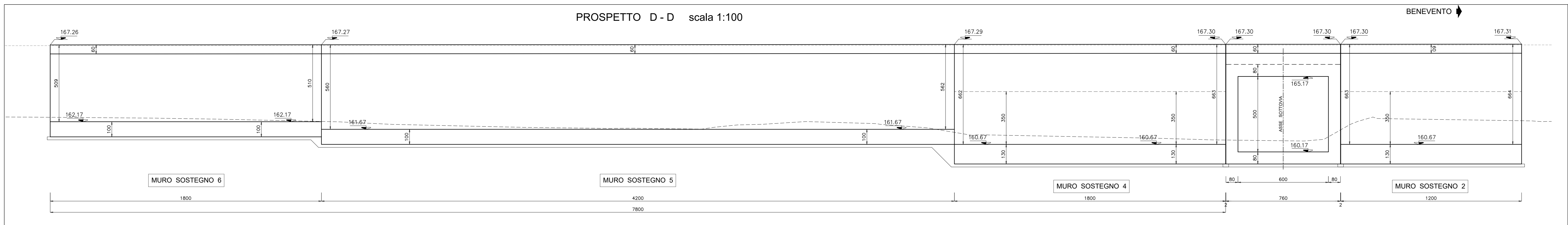

PIANTA SCATOLARE - MURI scala 1:100

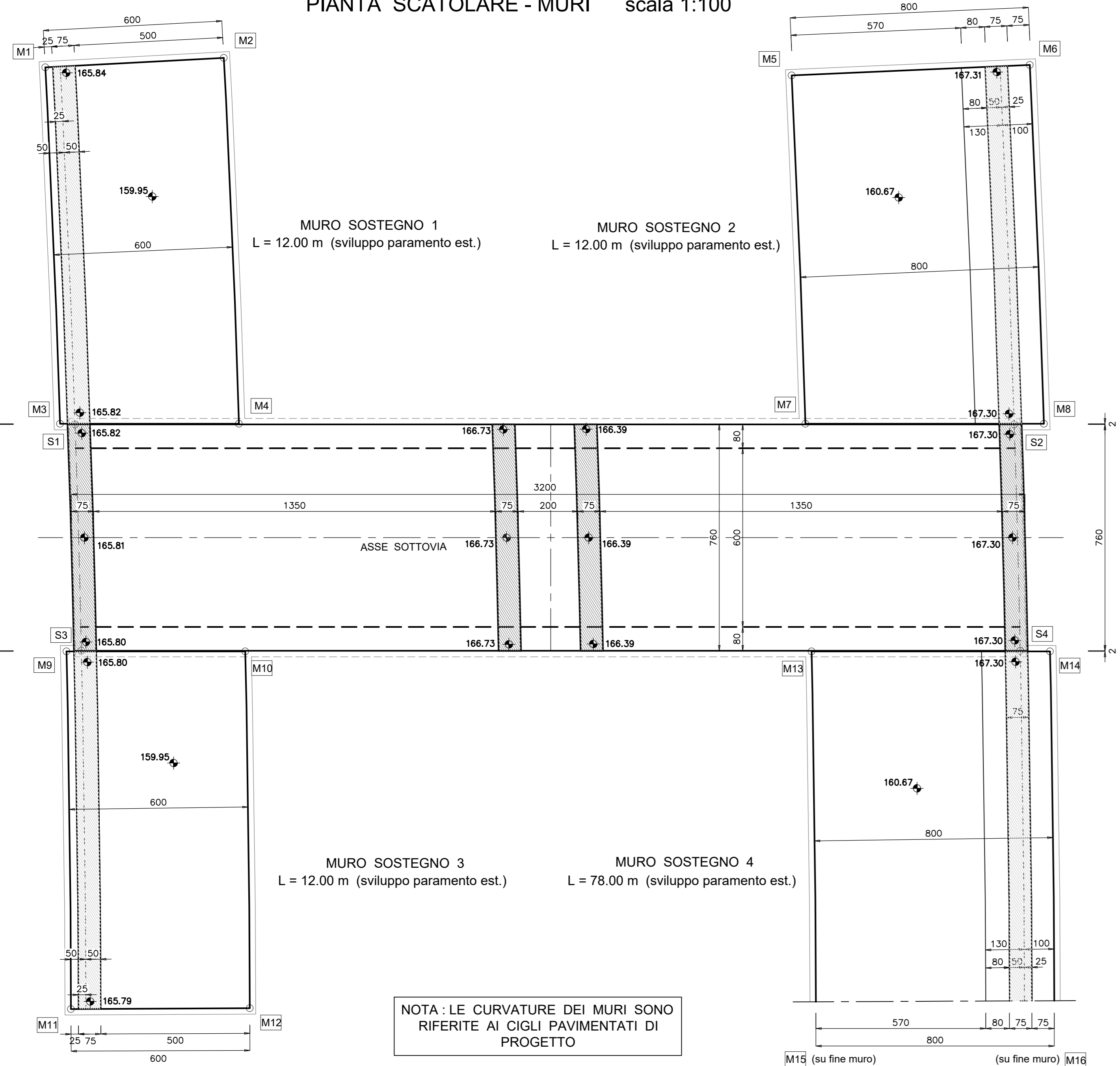

COORDINATE PUNTI NOTEVOLI

SOTTOVIA SCATOLARE			
NO	X	Y	ALTEZZA
01	165.84	159.95	0.00
02	165.84	159.95	0.00
03	165.84	159.95	0.00
04	165.84	159.95	0.00
05	165.84	159.95	0.00
06	165.84	159.95	0.00
07	165.84	159.95	0.00
08	165.84	159.95	0.00
09	165.84	159.95	0.00
10	165.84	159.95	0.00
11	165.84	159.95	0.00
12	165.84	159.95	0.00
13	165.84	159.95	0.00
14	165.84	159.95	0.00
15	165.84	159.95	0.00
16	165.84	159.95	0.00
17	165.84	159.95	0.00
18	165.84	159.95	0.00
19	165.84	159.95	0.00
20	165.84	159.95	0.00
21	165.84	159.95	0.00
22	165.84	159.95	0.00
23	165.84	159.95	0.00
24	165.84	159.95	0.00
25	165.84	159.95	0.00
26	165.84	159.95	0.00
27	165.84	159.95	0.00
28	165.84	159.95	0.00
29	165.84	159.95	0.00
30	165.84	159.95	0.00
31	165.84	159.95	0.00
32	165.84	159.95	0.00
33	165.84	159.95	0.00
34	165.84	159.95	0.00
35	165.84	159.95	0.00
36	165.84	159.95	0.00
37	165.84	159.95	0.00
38	165.84	159.95	0.00
39	165.84	159.95	0.00
40	165.84	159.95	0.00
41	165.84	159.95	0.00
42	165.84	159.95	0.00
43	165.84	159.95	0.00
44	165.84	159.95	0.00
45	165.84	159.95	0.00
46	165.84	159.95	0.00
47	165.84	159.95	0.00
48	165.84	159.95	0.00
49	165.84	159.95	0.00
50	165.84	159.95	0.00
51	165.84	159.95	0.00
52	165.84	159.95	0.00
53	165.84	159.95	0.00
54	165.84	159.95	0.00
55	165.84	159.95	0.00
56	165.84	159.95	0.00
57	165.84	159.95	0.00
58	165.84	159.95	0.00
59	165.84	159.95	0.00
60	165.84	159.95	0.00
61	165.84	159.95	0.00
62	165.84	159.95	0.00
63	165.84	159.95	0.00
64	165.84	159.95	0.00
65	165.84	159.95	0.00
66	165.84	159.95	0.00
67	165.84	159.95	0.00
68	165.84	159.95	0.00
69	165.84	159.95	0.00
70	165.84	159.95	0.00
71	165.84	159.95	0.00
72	165.84	159.95	0.00
73	165.84	159.95	0.00
74	165.84	159.95	0.00
75	165.84	159.95	0.00
76	165.84	159.95	0.00
77	165.84	159.95	0.00
78	165.84	159.95	0.00
79	165.84	159.95	0.00
80	165.84	159.95	0.00
81	165.84	159.95	0.00
82	165.84	159.95	0.00
83	165.84	159.95	0.00
84	165.84	159.95	0.00
85	165.84	159.95	0.00
86	165.84	159.95	0.00
87	165.84	159.95	0.00
88	165.84	159.95	0.00
89	165.84	159.95	0.00
90	165.84	159.95	0.00
91	165.84	159.95	0.00
92	165.84	159.95	0.00
93	165.84	159.95	0.00
94	165.84	159.95	0.00
95	165.84	159.95	0.00
96	165.84	159.95	0.00
97	165.84	159.95	0.00
98	165.84	159.95	0.00
99	165.84	159.95	0.00
100	165.84	159.95	0.00

NOTA: LE CURVATURE DEI MURI SONO RIFERITE AI CIGLI PAVIMENTATI DI PROGETTO

SEZIONE LONGITUDINALE A - A scala 1:100

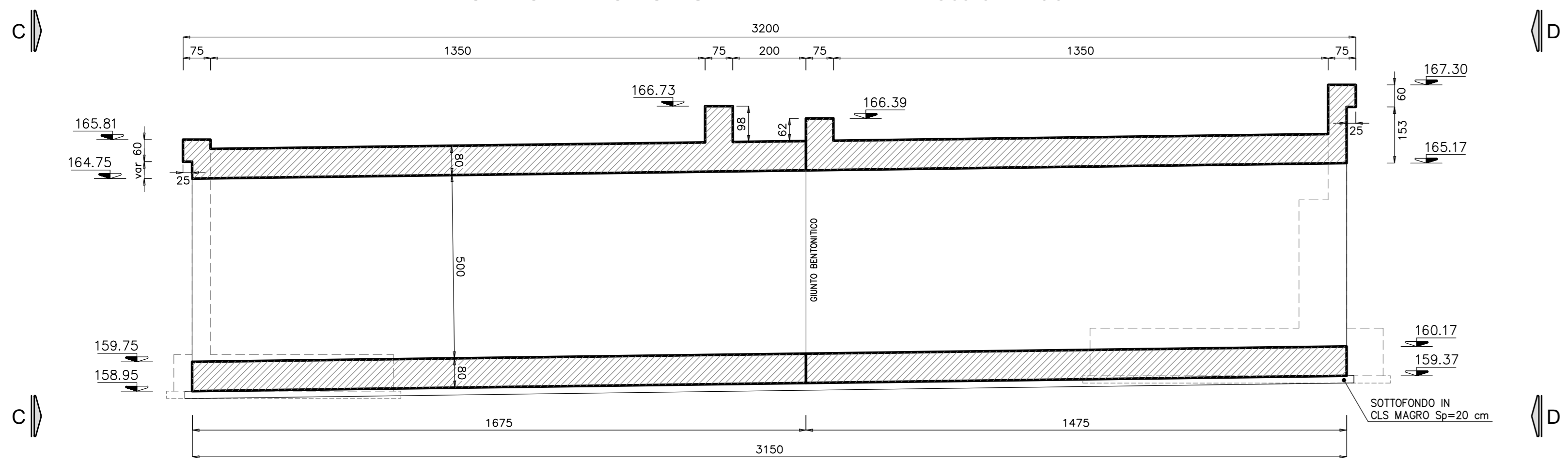

PROSPETTO C - C scala 1:100

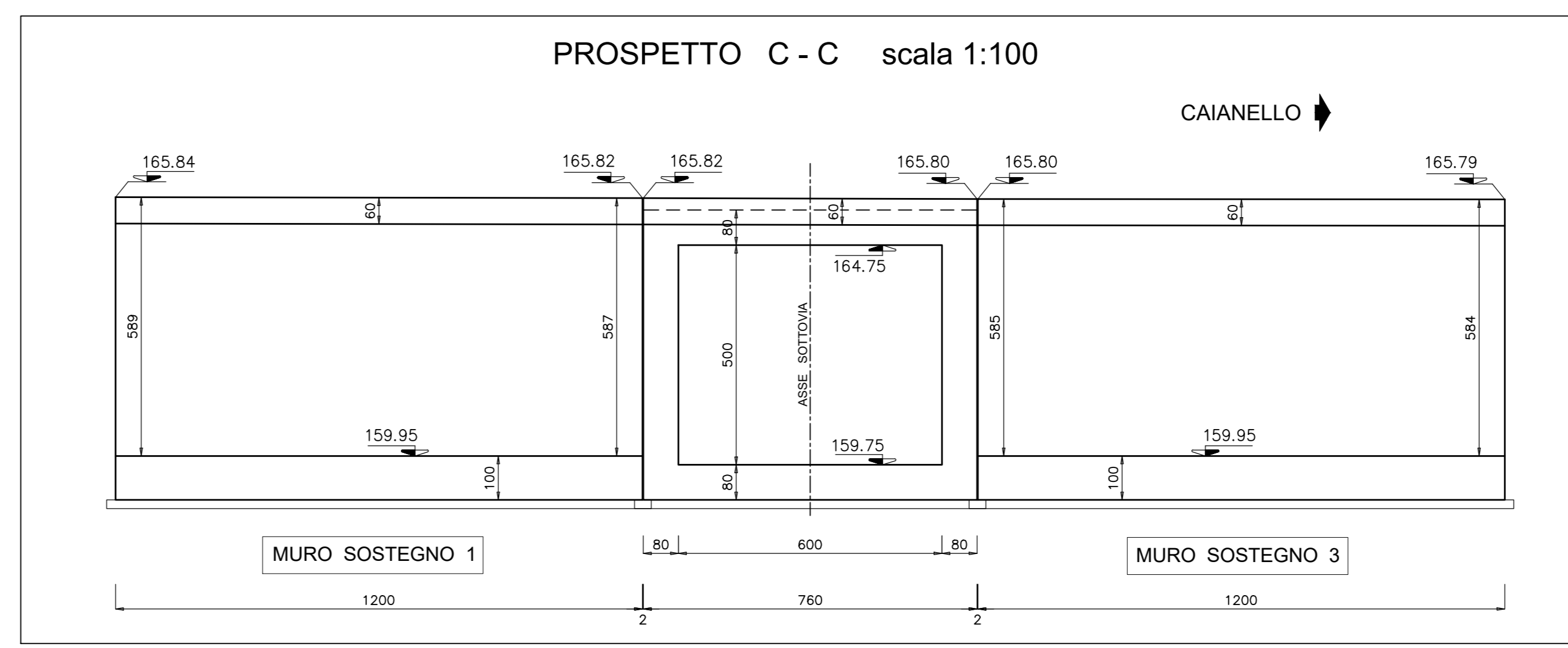

SEZIONE TIPO DRENAGGIO scala 1:50

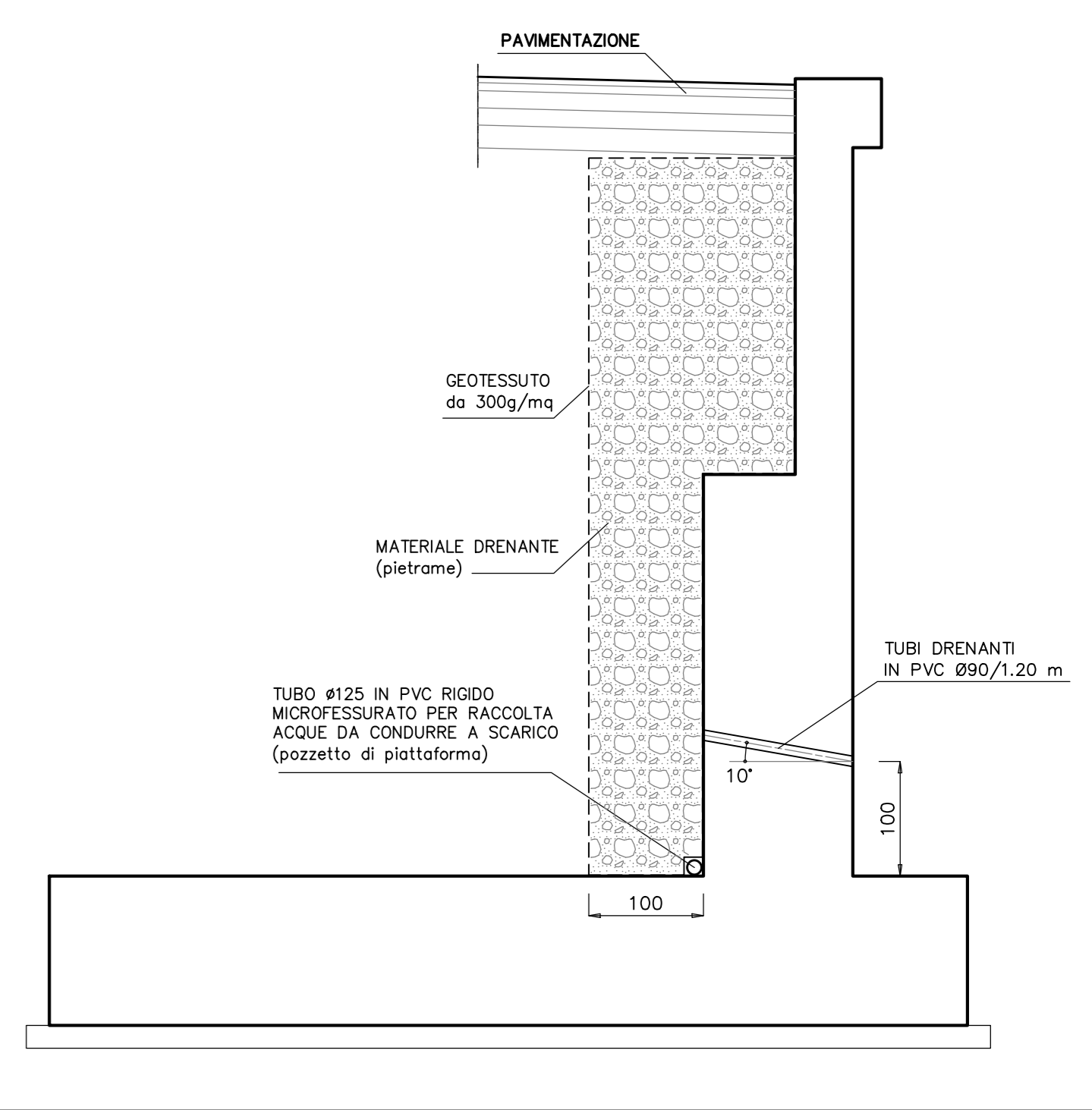

SEZIONE TIPO MURI 2 e 4 scala 1:50

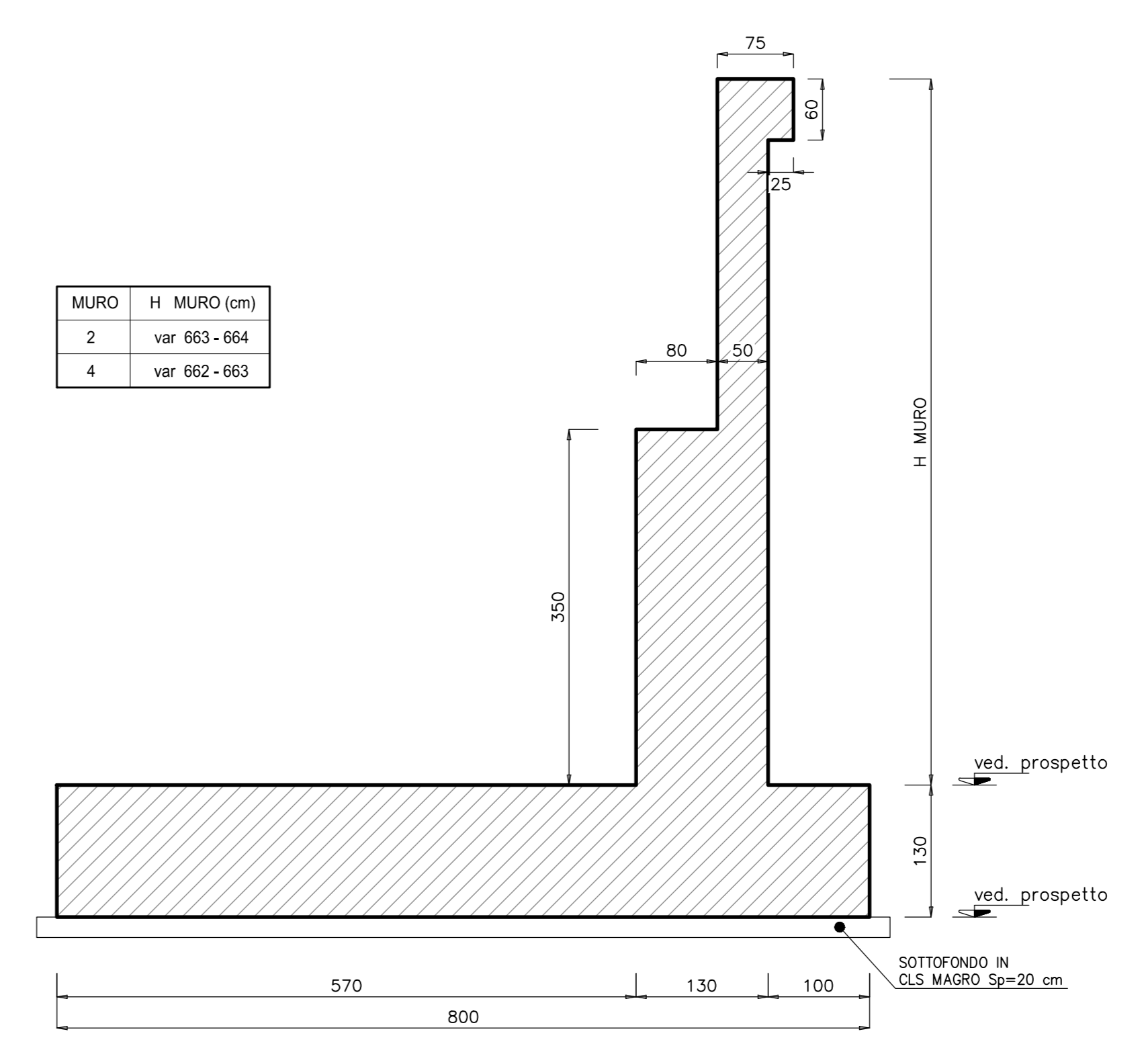

SEZIONE TIPO MURI 1-3-5 e 6 scala 1:50

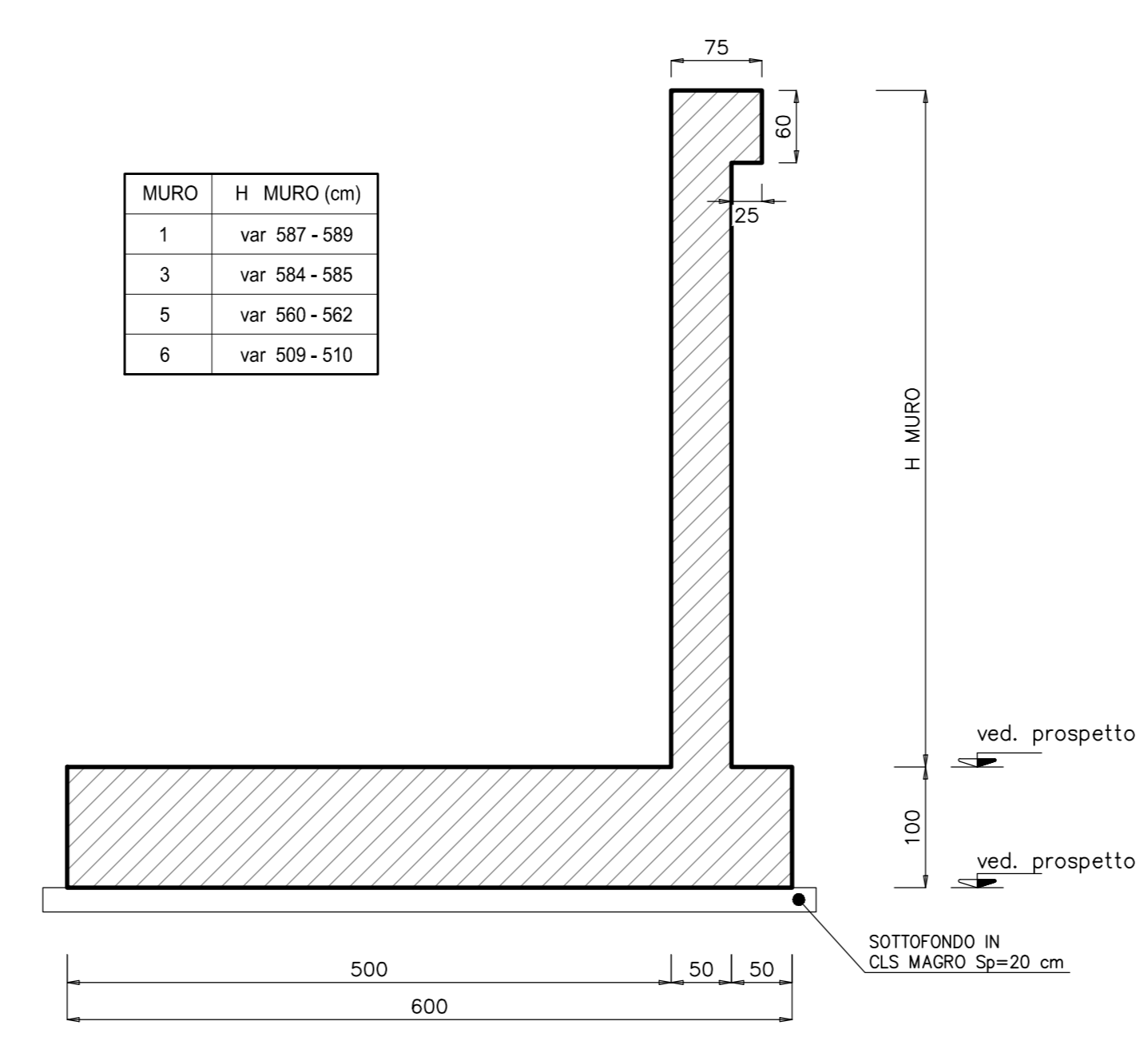

NOTA: PER I MATERIALI E LE PRESCRIZIONI VEDI TAV. T00_ST00_STR_SC01

ITINERARIO CAIANELLO (A1) - BENEVENTO
ADEGUAMENTO A 4 CORSIE DELLA S.S. 372 "TELESINA"
DAL KM 0+000 AL KM 60+900
LOTTO 2: DAL KM 0+000 (SVINCOLO CAIANELLO (A1))
AL KM 37+000 (SVINCOLO DI S. SALVATORE TELESINO)

PROGETTO DEFINITIVO cod. NA280

PROGETTAZIONE: ATIL S.T.E. - ROGNOSOL - ERM - KARRER		GRUPPO DI PROGETTAZIONE	
RESPONSABILE INTEGRAZIONE PRESTAZIONI SPECIALISTICHE Ing. Francesco M. La Camera	COORDINATORE PER LA SICUREZZA IN FASE DI PROGETTAZIONE Ing. Francesco M. La Camera	S.T.E. s.r.l. Structure and Transport Engineering	Direttore Tecnico Ing. E. Morre
IL GEOLOGO Dott. Geol. Firenze Plemmo	L'ARCHITETTOLOGO Dott.ssa Grazia Savino Elenca MBACT n.306 - architetto di Piacenza ai sensi del D.M. 244/2019	ROGNOSOL S.p.A.	Direttore Tecnico Ing. G. Casani
IL RESPONSABILE DEL PROCEDIMENTO Ing. Pompeo Volturno		E.D.I.N. s.r.l. EDIZIONI Società di Ingegneria	Direttore Tecnico Ing. G. Cimatti
		Prof. Arch. F. KARRER Ordine Arch. Roma N. 12097	

OPERE D'ARTE MINORI: SOTTOVIA E TOMBINI
ST01 - Sottovia scatolare 6,00x5,00 alla prg. 0+511,27
Prospetti e carpenterie

CODICE PROGETTO	NOME FILE	REVISIONE	SCALA
PROGETTO	T00_ST01_STR_CP01_A		
LO710F D 2101	CODICE ELAB. TOSTOSTRCP01	A	varie
D			
C			
B			
A	EMMISSIONE PER VERIFICA DI OTTEMPERANZA	Feb.2022	Strada Di Renato La Camera
REV.	DESCRIZIONE	DATA	REDATTO VERIFICATO APPROVATO